01 Sep 2018

An Overview of Direct Current Distribution System Architectures & Benefits

Venkata Anand Prabhala

Bhanu Prashant Baddipadiga

Poria Fajri

Mehdi Ferdowsi

Missouri University of Science and Technology, ferdowsi@mst.edu

Follow this and additional works at: https://scholarsmine.mst.edu/ele_comeng_facwork



Part of the [Electrical and Computer Engineering Commons](#)

Recommended Citation

V. A. Prabhala et al., "An Overview of Direct Current Distribution System Architectures & Benefits," *Energies*, vol. 11, no. 9, MDPI AG, Sep 2018.

The definitive version is available at <https://doi.org/10.3390/en11092463>



This work is licensed under a [Creative Commons Attribution 4.0 License](#).

This Article - Journal is brought to you for free and open access by Scholars' Mine. It has been accepted for inclusion in Electrical and Computer Engineering Faculty Research & Creative Works by an authorized administrator of Scholars' Mine. This work is protected by U. S. Copyright Law. Unauthorized use including reproduction for redistribution requires the permission of the copyright holder. For more information, please contact scholarsmine@mst.edu.

Review

An Overview of Direct Current Distribution System Architectures & Benefits

Venkata Anand Prabhala ^{1,*}, Bhanu Prashant Baddipadiga ¹, Poria Fajri ²  and Mehdi Ferdowsi ¹

¹ Electrical and Computer Engineering Department, Missouri University of Science and Technology, Rolla, MO 65401, USA; bbt68@mst.edu (B.P.B.); ferdowsi@mst.edu (M.F.)

² Electrical and Biomedical Engineering Department, University of Nevada, Reno, NV 89557, USA; pfajri@unr.edu

* Correspondence: vkpzvf@mst.edu; Tel.: +1-424-397-7779

Received: 12 August 2018; Accepted: 11 September 2018; Published: 17 September 2018



Abstract: This paper examines existing and future direct current (DC) distribution systems with a wide range of applications in data centers, telecommunication systems, commercial buildings, residential homes, electric vehicles, spacecraft, and aircrafts. DC distribution systems have many advantages and disadvantages over their alternating current (AC) counterparts. There are a few surviving examples of DC distribution systems; among them are the telecommunication systems and data centers that use the low-voltage 48 Vdc systems. However, recently, there has been a move towards higher DC bus voltages. In this paper, a comparative study of different DC distribution architectures and bus structures is presented and voltage level selection is discussed for maximizing system efficiency and reliability, reducing system costs, and increasing the flexibility of the system for future expansion. Furthermore, DC distribution systems are investigated from a safety standpoint and the current global market for these distribution systems is also discussed.

Keywords: DC distribution system; bus structure; power architectures; safety; protection; reliability; cost; voltage level

1. Introduction

DC power distribution systems were first proposed for lighting purposes and were patented by Edison in 1883 [1]. Due to limited advancements in DC technology, DC distribution systems were deemed inefficient and hence unsuitable for transmission of power over long distances. In 1886, Sprague proposed AC distribution systems [2]. With the invention of transformers and induction machines, AC distribution systems could transmit power efficiently over long distances. As a result, they became popular and were universally adopted for electric power distribution. The advent of the semiconductor industry in the 1960s led to the introduction of power electronic converters (PECs) that were capable of improving the performance of DC distribution systems. With everyday advancements in semiconductor technology, PECs are becoming more efficient, reliable, cheaper, and smaller in size. With the help of PECs, DC distribution systems are now becoming more beneficial than AC distribution systems in terms of efficiency, reliability, cost, size, etc. [3,4]. In references [5–13], the authors propose new topologies of PECs with high efficiencies and power densities that can be used to improve the overall efficiency of a DC distribution system.

A DC distribution system has many advantages over an AC distribution system. It offers higher efficiency and reliability at an improved power quality. It has reduced installation costs as it requires fewer power conversion stages, less copper, and smaller floor space. DC distribution enables simpler integration of renewable energy sources and energy storage systems. Since the power is distributed in DC, there is no reactive power or skin effect in the system. Unlike the AC

distribution system, a DC distribution system facilitates plug and play features as it does not require any synchronization. Telecommunication systems and data centers are among the few surviving examples of DC distribution systems. They are low voltage (48 Vdc) power systems that have characteristics similar to a conventional DC distribution system. The requirement of DC power for major consumer electronic loads and recent developments in renewable energy technology as well as increased penetration of distributed energy resources have prompted renewed interest in DC distribution systems among researchers and industry players.

Ideally, a power delivery architecture should maximize system efficiency and provide power at a low cost. It should also be able to reliably supply power to critical and sensitive loads such as data centers, as these applications require uninterrupted power supply. Moreover, there should be room for further expansion as and when necessary. In this paper, different DC distribution system architectures are discussed and a comparative study is presented. The authors of references [3,4], and references [14–22] show different power delivery architectures used for both AC and DC systems for different voltage levels. The optimum DC bus voltage level selection is done to maximize system efficiency, reliability, and flexibility of the system for future expansion while reducing system costs. Until the last decade most telecommunication and data centers were operating at 48 Vdc, as it is within the safe extra low voltage limits of the European Telecom standards EN41003 and UL 1950 to avoid hazards [20,21]. Recently, there has been a trend towards moving to higher DC bus voltages to reduce system costs and losses. However, there are challenges involved with higher DC bus voltages like safety and protection that can lead to fire hazards. Furthermore, the reliability of the system is also affected, as there is an increased risk of component failure involved with increased voltage and current stresses. This paper discusses the DC bus voltage level selection based on different safety standards and investigates the different aspects of DC systems in terms of system reliability and efficiency, ease of integration of renewable energy and energy storage systems, and availability of protection equipment and components.

In this paper, Section 2 gives a brief overview of different power distribution architectures and DC bus structures for DC distribution systems at different voltage levels. Section 3 discusses the efficiency improvement in DC systems. The safety, grounding, and protection aspects of DC systems are discussed in Section 4. Sections 5 and 6 discuss the reliability and cost of DC distribution systems. The DC bus voltage level selection is discussed in Sections 7 and 8 gives insight into the current global market for DC distribution system in terms of facilities deployed, standards established, components available, and market penetration. Finally, conclusions on DC distribution systems are provided in Section 9.

2. DC Distribution—Bus Structures and Power Architectures

2.1. DC Bus Structures

A DC distribution system can be considered a DC bus connected to various sources (AC grid, renewables, and energy storage systems) and loads (electronics, lighting, variable speed drives, etc.); typically, AC grid being the main source of supply. Four different DC bus structures are described in this section. Reliability and cost are the main factors considered in determining the bus structure for a distribution application.

2.1.1. Radial Bus Structure

This type of distribution structure is the most simple and economical in terms of implementation. The DC bus runs from one end to another with the sources and loads connected anywhere depending on their location, as shown in Figure 1a. The reliability of the system is the least compared to other bus structures as a fault on the DC bus will result in the shutdown of the entire system.

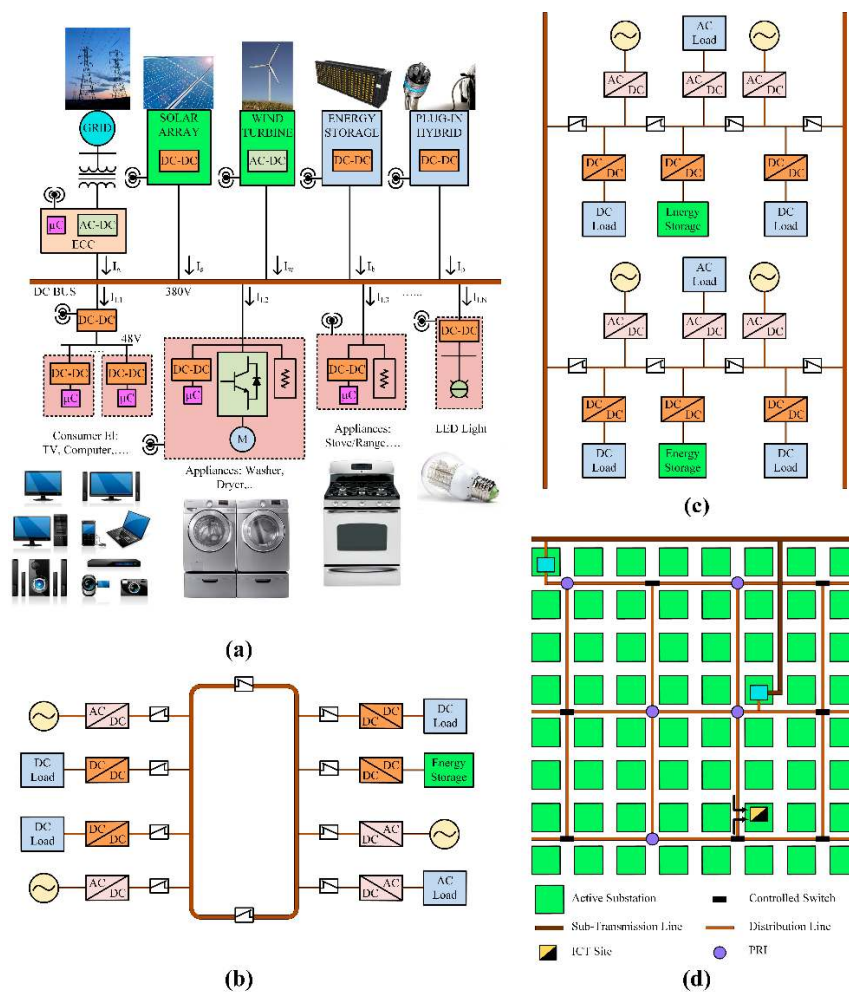

Figure 1. DC bus structures: (a) radial; (b) ring; (c) ladder; (d) meshed.

2.1.2. Ring Bus Structure

As the name suggests, in this configuration the DC bus is in the form of a ring. This bus structure is more expensive than the radial one as it involves more copper. It also has improved reliability at increased cost. As seen in Figure 1b, the DC bus is divided into two sections using switchgear. Thus, when there is a fault on the DC bus, the switchgear can be used to isolate the faulted DC bus from the un-faulted DC bus, thereby ensuring continuity in operation on the segment of the system with no fault.

2.1.3. Ladder Bus Structure

In this structure, the DC bus in the shape of a ladder increases the reliability of the system with an increase in cost compared to the ring bus structure. Ladder bus structure is an extension of the ring structure with higher reliability. As seen in Figure 1c, when a fault occurs at any point in the system, the faulted region of the bus can be isolated from the rest of the system using appropriate switchgear.

2.1.4. Meshed Bus Structure

The meshed bus structure shown in Figure 1d is a modified ring bus structure obtained when multiple ring structures are joined together. A system with meshed bus structure has the highest reliability compared to the other three structures. Obviously, this structure is the most expensive of all as it requires more copper.

It is observed that the higher the reliability requirement, the higher the cost of the system will be. Therefore, the selection of the bus structure is based on how reliable the system must be and how much one is willing to pay for it. For residential applications, where reliability is not a dictating factor, a simple radial bus structure can be implemented. One good example of a radial DC bus structure is the DC nanogrid architecture [16], where the renewable energy sources and storage systems are integrated along with the existing power grid. If an application demands even higher reliability, one can choose from ring, ladder, or meshed bus structures depending on the budget and level of desired reliability. Highly reliable ring, ladder or meshed structures can be seen in telecommunication systems and data centers. A comparison of the advantages and disadvantages of the four DC bus structures discussed in terms of reliability, number of components, and cost is presented in Table 1.

Table 1. Advantages and disadvantages of different DC bus structures.

System Features	Radial Bus	Ring Bus	Ladder Bus	Meshed Bus
Power Reliability	Very Low	Moderate	High	Very High
No. of Components	Low	Moderate	High	Very High
Cost	Very Low	Low	Moderate	Very High

2.2. Power Architectures

In general, power architectures for a DC power system can be classified into centralized and distributed architectures [21,22]. The first DC power system introduced was a centralized architecture. In this system architecture, the power was generated, processed, and controlled in one centralized unit and delivered to loads through a network of power conductors or cables. The simple block diagram representation of a centralized power system architecture is shown in Figure 2a. This type of system architecture is effective if the loads are all of a defined voltage level. As time progressed, the number of loads with different voltage levels increased on the system and eventually, the centralized power architecture could no longer support the needs of the loads. As a result, distributed power system architecture was developed that powered the loads through a number of PECs as shown in Figure 2b.

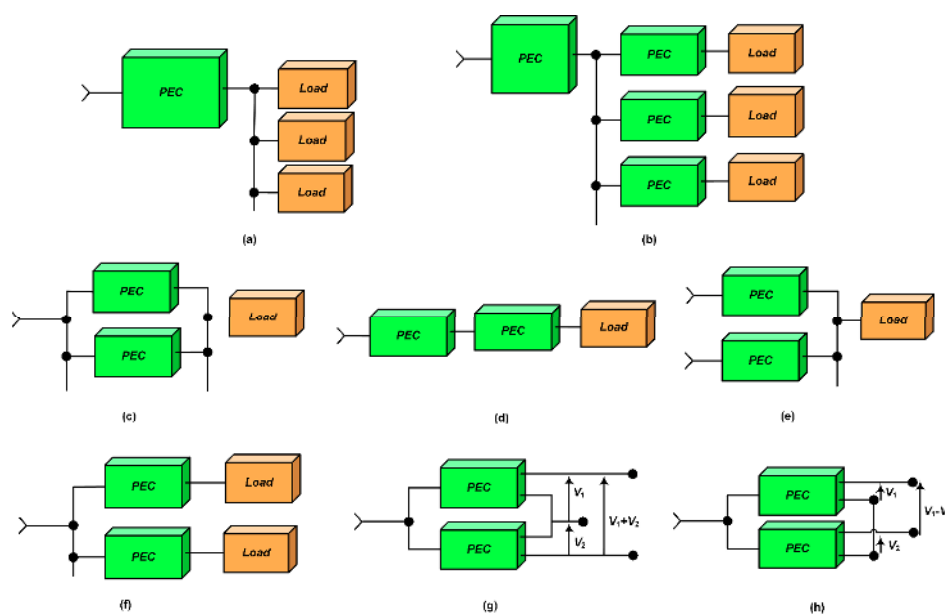

Figure 2. Power architectures: (a) centralized; (b) distributed. Distribution configurations: (c) parallel; (d) cascading; (e) source splitting; (f) load splitting; (g) sum stacking module; (h) difference stacking module.

Distributed power system architecture comprises of different PECs, which provide different voltage level outputs catering power to various loads. With ever increasing power demand and loads at different voltage levels, distributed power system architecture gained acceptance, globally replacing the centralized power system architecture. By using smaller PECs, this architecture enables the use of standardized low power modules that make it easy to customize an existing system for any special requirements in the future. PECs can be made more efficient with increased power density by operating at high frequencies, as they are required to handle low power. Higher reliability can be achieved by isolating a fault on one module and keeping the rest of the system unaffected. The various merits of distributed power architecture can be attributed to five basic configurations that are used in order to supply specific loads. They are as follows:

2.2.1. Paralleling

In a paralleling configuration shown in Figure 2c, instead of using a single high power module, multiple low power PEC modules are connected in parallel to supply the load. Since a module processes part of the power, it experiences reduced thermal and electrical stresses, making the overall system more reliable even on increased component count. Individual modules can be reduced in size, cost, and made with a higher power density by operating at higher frequencies. This configuration provides simple maintenance and high reliability using redundancy (using 'n+1' modules instead of required 'n' modules).

2.2.2. Cascading

In a cascaded configuration shown in Figure 2d, an intermediate bus is introduced into the power conversion of high voltage to a low voltage, which reduces power transformation losses. Also, distribution efficiency is improved when the converter is placed close to the load. The intermediate bus can be used for energy storage integration, improving the reliability and power quality. Cascaded units can be used for different purposes that are difficult to supply by a single converter. An example of such a cascaded configuration is a rectifier cascaded with a DC–DC converter where the rectifier can be used to achieve unity power factor and the DC–DC converter can be utilized for load voltage regulation.

2.2.3. Source Splitting

Source splitting configuration as shown in Figure 2e, enables the use of multiple sources to supply one load. The power redundancy and simple battery backup feature improves the power quality and reliability of this system.

2.2.4. Load Splitting

In load splitting configuration, as shown in Figure 2f, loads are supplied using multiple PECs. This configuration provides better load regulation, which can be difficult to achieve using a single centralized PEC because of the bus impedance. Moreover, this configuration allows selective battery backup for critical loads, which reduces the size and cost of batteries used in the system. Also, as different loads are supplied from separate sources, noise interference is reduced.

2.2.5. Stacking

Stacking configuration of PECs is mainly used to achieve desired output voltage levels by combining the outputs of multiple units. By stacking standardized units, non-standardized outputs can be obtained. For high voltage loads, the outputs of different PECs can be added as shown in Figure 2g. When a smaller voltage than standardized voltage is required, the difference of outputs can be obtained by connecting the outputs as shown in Figure 2h.

3. Efficiency

Efficiency improvement achieved using DC distribution systems compared to AC distribution systems can be attributed to various reasons. The main reason for higher efficiency of DC systems is it requires lower number of power conversion stages. In current architectures, the majority of residential and commercial loads comprise of electronic loads that require DC power. To supply these loads using a conventional AC distribution system, a power electronic converter is required to first convert AC to DC. This power conversion from AC to DC results in additional power losses, usually about 4–15% of the input power; assuming the converters are 85–96% efficient. Therefore, the total system losses become relatively high as the number of power converters increase. Applications using variable speed drives, a washing machine or heating, ventilation, and air conditioning (HVAC) systems for example, require a rectifier for AC to DC conversion and then another converter to generate variable AC. Having a DC system eliminates the use of the rectifier stage thereby improving the system efficiency.

The power conversion road map for AC and DC power systems given in Table 2 [23] shows that DC systems have fewer conversion stages compared to AC systems for DC loads, AC loads, and AC loads with AC converters (ACwC Load).

Table 2. Power conversion roadmap for AC and DC power systems [23].

System	Source	DC Load	AC Load	ACwC Load
AC	DC	DC–AC–DC	DC–AC	DC–AC–DC–AC
	AC	AC–DC	-	AC–DC–AC
DC	DC	-	DC–AC	DC–AC
	AC	AC–DC	AC–DC–AC	AC–DC–AC

From another point of view, the absence of reactive power and skin effect are other reasons for improved efficiency in a DC distribution system compared to an AC distribution system. Since there is no reactive power in a DC system, the apparent and active powers are equal, which results in reduced losses in the system. In an AC system, skin effect increases the effective resistance of the wires and therefore results in higher distribution losses. Since such an effect is absent in a DC system, it has better efficiency than an AC system.

Various studies have been performed to validate the efficiency improvement in a DC distribution system. Lawrence Berkley national laboratory (LBNL) started investigating the DC distribution efficiency in data centers in 2004. The results obtained in their study stated that DC distribution consumed 28% less power compared to a typical AC distribution in data centers [20,24,25]. In reference [26], 220 Vac distribution was compared to 400 Vdc for power distribution in buildings. It was observed that in switching from AC to DC, an efficiency gain of 17.7%, 9.49%, and 18.9% was achieved in office, residential, and school buildings, respectively. The investigation carried out in [25] concluded that at 50% load, 380 Vdc system was the most efficient among the systems considered for study. The results of this study are shown in Table 3. The author of reference [27] explains that when a distribution system integrated with DC sources (e.g., fuel cells, solar panels, etc.) was considered, a DC distribution system was more efficient than an AC system.

Table 3. Efficiency comparison of five distribution systems at 50% load [25].

System	Uninterruptible Power Supply (UPS)	Distribution	IT Power Supply	Overall Efficiency
480 to 208 Vac	96.20%	96.52%	90.00%	83.56%
400/230 Vac	96.20%	99.50%	90.25%	86.39%
48 Vdc	92.86%	99.50%	91.54%	84.58%
380 Vdc	96.00%	99.50%	91.75%	87.64%
Hybrid 575 Vdc	95.32%	92.54%	91.54%	80.74%

Low voltage DC systems designed for applications such as telecom and datacenters operate at 48 Vdc. At least three conversion stages from the AC input to the load are required to achieve this voltage level, which reduces the system efficiency. In references [28–36], different voltage levels have been proposed for a DC bus based on efficiency, cost, and reliability considerations. In references [3,4], three different power architectures, namely conventional AC architecture, rack-level DC architecture, and facility-level DC architecture, have been described that are commonly utilized in data and telecom centers. Conventional AC system architecture for data center applications, shown in Figure 3a, has several conversion stages that include the double conversion stage of the uninterruptible power supply (UPS). The AC input voltage is first converted to DC, where the energy storage system is connected, and then converted back to AC. In the next stage the voltage is stepped down to 208 Vac using a transformer in the power distribution unit (PDU). This AC voltage is once again converted to a DC voltage in the range of 380–400 Vdc using an AC–DC converter in the power supply unit (PSU). Isolated DC–DC converters are used to step down the voltage to levels suitable for distribution to the loads. For this configuration the overall system efficiency when operated at high load conditions is typically around 50%.

In the rack-level DC configuration presented in Figure 3b, the AC–DC converter is shifted from the PSU of the server to the rack, thus reducing the server cooling requirements. The server volume is also reduced and the whole consolidated rack has higher power density and improved light load efficiency. Compared to the conventional AC architecture, an improvement in the overall system efficiency is not expected since the number of conversion stages are the same.

In the facility-level DC architecture shown in Figure 3c, the DC–AC conversion stage in the UPS, the AC–DC conversion stage in the PSU of the server, and the transformer in the PDU are removed. Therefore, the number of conversion stages are reduced and the power delivery efficiency is significantly increased.

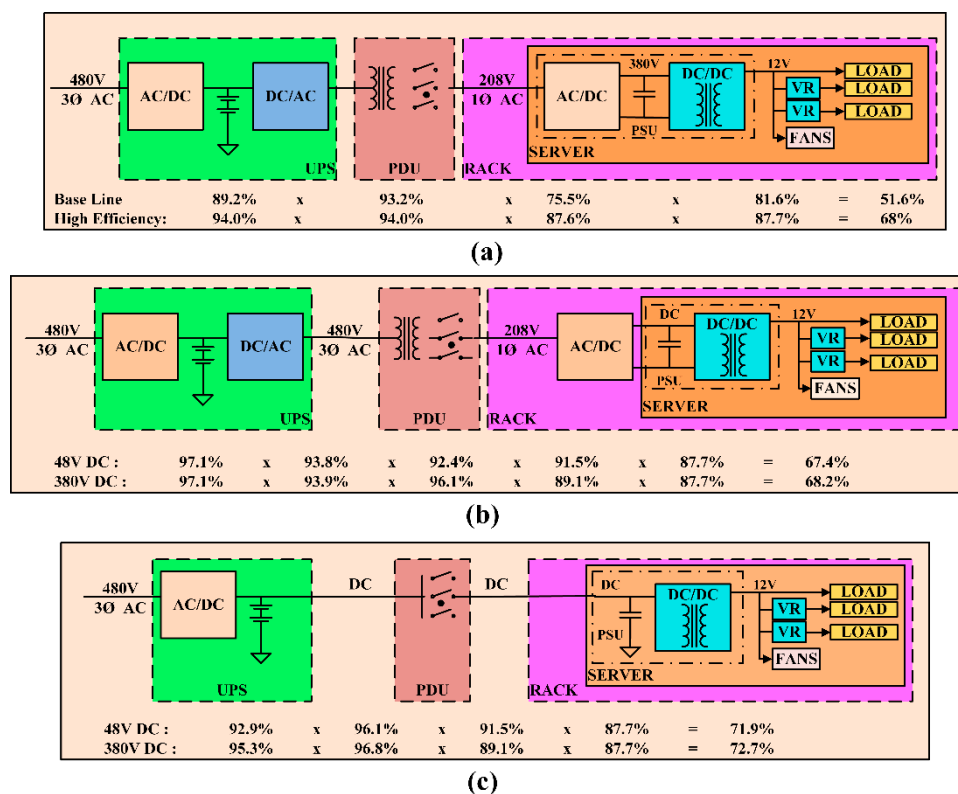

Figure 3. Power architectures in telecom and data centers: (a) conventional AC architecture; (b) rack-level DC architecture; (c) facility-level DC architecture [4].

In reference [36], a 380 Vdc modified power delivery architecture was proposed for server applications because it is more efficient than the conventional 48 Vdc system. In the modified power delivery architecture, the improvement in efficiency is obtained by reducing the number of power conversion stages and placing isolated DC–DC converters close to the load. Based on the abovementioned references and their claims, one can reach the conclusion that not only is a DC distribution system more efficient than a conventional AC system, but a higher voltage DC system also offers higher efficiency.

4. Safety and Protection

Two of the main concerns associated with DC distribution are the risk of electric shock and protecting equipment from damage that can also result in electric fires. The main reason behind this concern is that it is challenging to break a DC current compared to an AC current. Switchgear including circuit breakers, fuses, etc., and proper grounding methods are required to make the DC system safer. Comprehensive research has been conducted and papers have been published on improving the safety in DC distribution systems [37–40]; different papers have studied protection against electric shock related to DC generating devices such as photovoltaic generators from the perspective of personal safety [41,42]. Moreover, higher DC voltage levels would result in leakage currents in the system that can cause corrosion of the underground equipment, transformer saturation, and faulty operation of protective equipment [43].

4.1. Personal Protection

In order to evaluate personal protection and safety requirements of DC and AC systems, it is important to understand the effects of DC and AC currents on human body. The effect of an electric shock depends on the current magnitude, the duration of current, the current path, and the type of voltage (AC or DC). Among all the possible effects of electric shock, ventricular fibrillation is the most dangerous. Hence, in order to prevent any casualties proper protection needs to be provided. The authors of [37,39], provide a characteristic curve of body current (AC and DC) vs. the duration of current flow, which is shown in Figure 4.

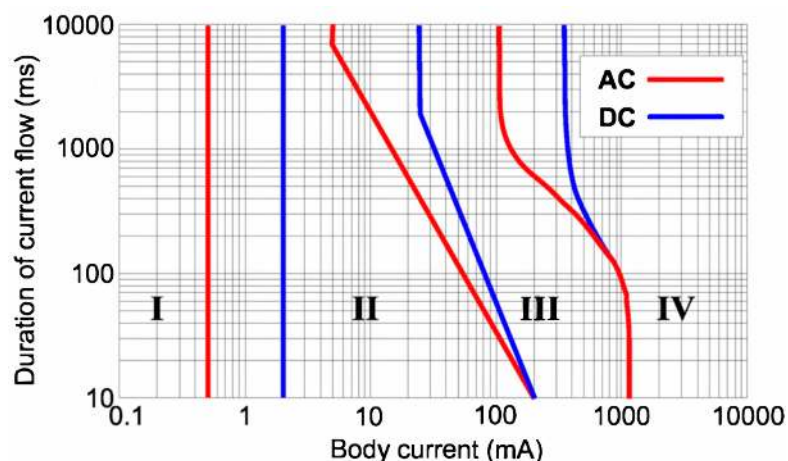

Figure 4. Characteristic curve of body current vs. duration of flow, IEC/TR 60479-5 [37].

The graph is divided into four regions based on the effects on the human body:

- I. No effect
- II. A little pain but no dangerous effects
- III. Muscular contraction and respiratory compromise, which are reversible
- IV. Critical effects such as ventricular fibrillation

It can be observed from the figure that the magnitude of safe operating current limit for DC is higher compared to AC, thus making DC safer to operate than AC.

4.2. Equipment Protection

Protective devices such as circuit breakers and fuses are similar for both the AC and DC systems. However, in the case of DC systems, they have to tolerate more stress while breaking the current due to the persistent nature of the arc. For residential applications and DC buildings, circuit breakers are commonly used instead of fuses as they can be reset when the fault is cleared. As the voltage and current ratings of the circuit breakers are lower for a DC system compared to an AC system, same components can be used for protection on both the AC and DC sides of a system. Furthermore, in the event of a short circuit, individual converters are usually equipped with short circuit protection and can easily detect a fault by observing the DC bus voltage. In such cases, when the DC bus voltage falls below a certain threshold, the controller can identify a short circuit and shut down the system. However, DC fault currents in some compact devices pose many challenges that demand advanced electrical protection requirements, therefore making the selection of suitable DC circuit breaker technology much more challenging [44].

Many advantages of DC distribution systems are currently driving the market growth for DC technologies. Since equipment protection has been a major concern, many companies have been researching DC protection devices. Currently, major companies have started providing products used in DC distribution that follow existing standards for safety. Companies like ASEA Brown Boveri (ABB), Carling Technologies, Schneider, Nader, Siemens, etc., provide DC circuit breakers and fuses to be used for safety and protection purposes in DC distribution systems. Figure 5a shows the design features of CX-series circuit breakers of Carling Technologies that is ideal for 380 Vdc applications [45]. It uses a special arc-quenching method, enabling it to break high DC currents and handle high DC voltages.

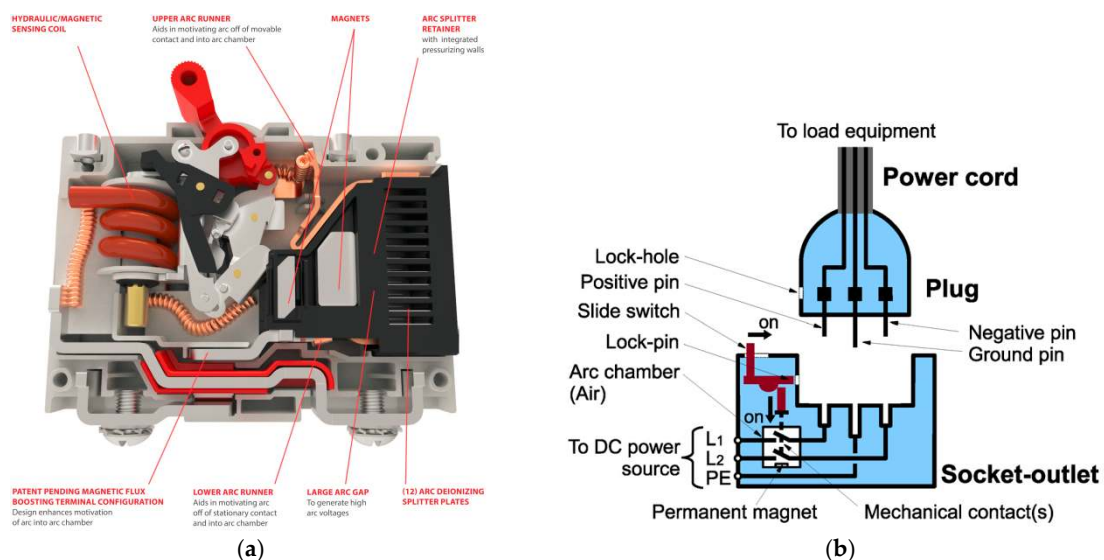

Figure 5. (a) Design features of Carling Tech DC circuit breaker (© of Carling Tech) [45]; (b) configuration of DC plug and socket outlet system (© of NTT Facilities) [38].

DC distribution systems for commercial buildings and data centers require a distinctive plug and socket that should provide arc extinction as well as prevent electric shocks. These plugs are also equipped with mechanical locks to ensure human safety. The Nippon Telegraph and Telephone (NTT) Corporation and Fujitsu Component Limited have developed a 400 Vdc, 10 A plug and socket, as shown in Figure 5b, which can be used for DC distribution system [38]. When a DC current is interrupted, the resulting arc can damage the equipment. To prevent this, the plug should not be removed from the socket when the power supply is on. However, there can be instances during

emergencies or when the plug is accidentally removed from the socket while the power is still on. During those cases, the plug and socket should be capable of taking care of the arc extinction and shock prevention tasks.

4.3. Grounding Methods

Grounding is a mandatory requirement in distribution systems as it provides personal safety and decreases the risk of fire hazards. Also, it reduces equipment damage, service interruptions during short circuit and earth faults. Other advantages of grounding include reduced radiation and conduction of electromagnetic emissions, providing tolerance to electrostatic discharge and lightning interference. Different grounding methods discussed in [37,39,40] are as follows:

4.3.1. Direct Grounding Method

This type of grounding involves connecting one of the lines directly to the ground. There are three ways in which direct grounding can be implemented. They are listed below:

1. Positive line grounding: In this system, the positive line is connected to ground as shown in Figure 6a. This system provides easy detection and breaking of current during a short circuit or earth fault. Monopole breaking is used to break the current. During a fault, the direction of the current through the human heart is upward and the heart-current factor F [39] is twice that of the direct negative grounding system. As a result, it seems like twice the current is flowing through the human body. The current one receives during an electric shock in this type of grounding is the largest among all the grounding systems as the circuit impedance is very low. However, as the fault current is large, it can be interrupted with better accuracy.
2. Negative line grounding: In this type of grounding the negative line is connected to the ground as shown in Figure 6b. The properties of this grounding method are similar to positive line grounding. The current one receives in this type of grounding is usually high, but not as high as positive line grounding.
3. Mid-point line grounding: In this type of grounding, the voltage to grounding is half of that compared to one end grounding as shown in Figure 6c. It is easy to detect and break currents during short circuit and ground faults. The current is usually large when short circuit or earth faults occur on the negative line. When breaking fault current, it is necessary to break both the positive and negative lines at the same time. Usually, rectifiers and batteries implement this type of grounding and hence they need to deal with higher initial costs.

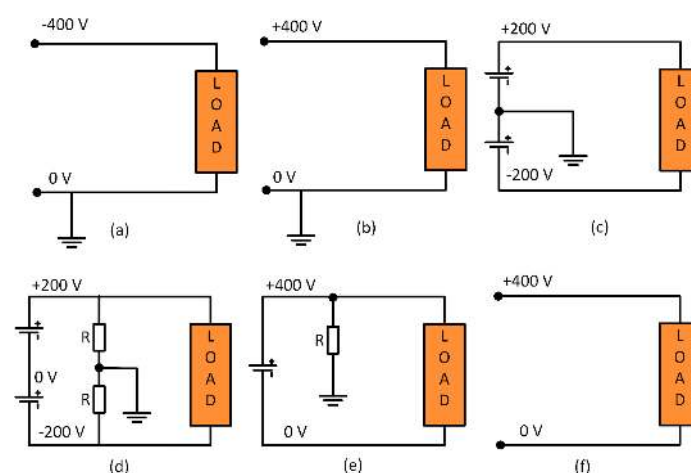

Figure 6. Grounding methods: (a) positive line; (b) negative line; (c) mid-point; (d) mid-point high resistance; (e) one-end high resistance; (f) floating system.

4.3.2. Mid-Point Grounding with High Resistance

Compared to a direct grounding system, this method makes protection against electric shock easier and the voltage to grounding is halved. Unlike in direct grounding, this method requires a resistance balancer in order to avoid any difference in ground voltage between positive and negative lines. Also, detecting an accidental current is difficult during faults as the magnitude of the current is small due to the high resistance. Hence, this method has decreased detection accuracy. Similar to mid-point line grounding, both the positive and negative lines have to be disconnected at the same time. In the mid-point high resistance grounding system, as the number of loads increases, the total resistance of the system decreases and the fault current is no longer small. A simple representation of this type of grounding is shown in Figure 6d.

4.3.3. One-End Grounding with High Resistance

This method provides an even easier detection and breaking of fault currents compared to the direct grounding system. Monopole breaking of accidental current is possible as it is a one-end grounding method. However, detecting an accidental current is difficult since the magnitude is small and hence it has decreased detection accuracy. Just like in mid-point high-resistance grounding, the combined resistance decreases as the number of loads increase.

4.3.4. Floating System

In this type of grounding, there is no return path to ground and hence the current received during an electric shock is almost zero. This type of system is not very safe because just like in high-resistance grounding systems, the combined insulation resistance of the system decreases as the number of loads increase. Also, implementing such a system is very expensive as the devices used will require complete isolation. It is difficult to detect an earth fault and the voltage to ground may not be constant.

According to [37], based on its merits; NTT Facilities, France Telecom, and Emerson network power have selected and highly recommend high resistance mid-point grounding for 400 Vdc distribution systems. This method provides better personal safety (by limiting fault currents to harmless levels) compared to other grounding methods for higher DC voltages.

5. Reliability

The reliability of both AC and DC systems depends on their system architecture and the level of redundancies. Especially, in DC systems, increasing the system voltage level adversely affects the electrical stresses experienced by the components (switches, breakers, etc.), thereby reducing the reliability of the system. Switching devices like power MOSFETs, IGBTs, diodes, etc. should always be operated within their safe operating area and, hence, are selected considering enough safety margins to take care of the voltage and current transients.

It has been observed that an increase in bus voltages reduces the life of capacitors [46]. The lifetime of electrolytic capacitors is given by

$$L = L_0 \times M_v \times 2^{\left(\frac{T_{core_max} - T_{core}}{10}\right)}. \quad (1)$$

In the above equation, L is the lifetime (hours), L_0 is the base lifetime at maximum core temperature (hours), T_{core} and T_{core_max} are the normal and maximum operating temperatures of the core ($^{\circ}\text{C}$) respectively, and M_v is the voltage multiplier, which is the ratio of rated voltage to the applied voltage. The life of the capacitors is adversely affected when they are subjected to higher voltage and current stresses, which causes their core temperature to rise, resulting in degradation of their performance. Therefore, it is very important to select suitable capacitors with sufficient voltage ratings. On the other hand, DC systems with higher DC bus voltages would require smaller capacitances because for the same amount of power the capacitance is inversely proportional to the square of voltage. Thus,

the system reliability can be improved by selecting capacitors with sufficient voltage ratings and by also using a series-parallel combination of capacitors.

If batteries are used for energy storage in higher voltage DC systems, then more battery cells would be required to be connected in series to attain the required voltage. This leads to reduced system reliability as the failure in any one cell in the string of cells would result in the failure of the whole battery pack. This issue can be addressed by using high-efficiency, high-gain bidirectional power converters and having a reduced number of series battery cells, making the system more reliable. Figure 7 shows the field data collected by NTT facilities of Japan on AC UPS and DC power supplies [47]. It can be seen from the plot that DC power supplies are less prone to failures compared to AC UPS systems. In [48], a static reliability modeling approach was used to compare the reliability and availability of different AC UPS topologies and 380 Vdc topologies typically used in the telecom and data center applications. The reliability of a system can be calculated based on the MTBF (Mean Time between Failures) and MTTR (Mean Time to Repair) of the components, sub-systems, and other relevant events.

$$A = \frac{MTBF}{(MTBF + MTTR)} \quad (2)$$

$$U = \frac{MTTR}{(MTBF + MTTR)} \quad (3)$$

$$R(t) = e^{-t/MTBF}, \quad (4)$$

where, A and U are the availability and unavailability of the system, respectively, and $R(t)$ is the time-dependent reliability function. It has been shown that the reliability and availability of the DC UPS system is 10 times higher than that of the AC solution.

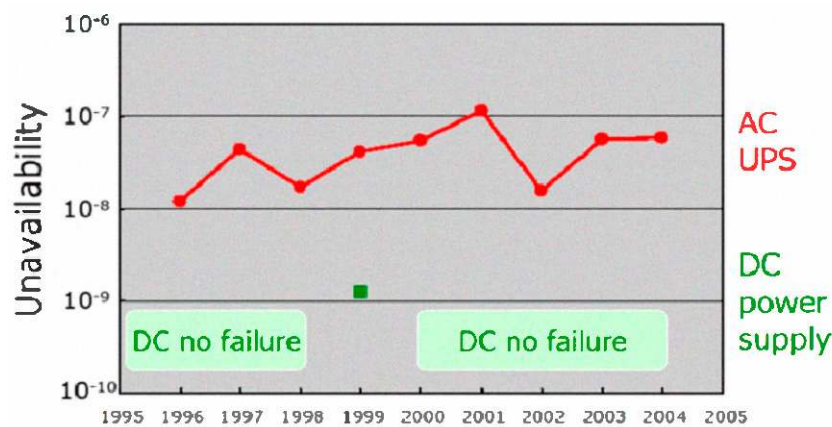

Figure 7. Reliability field data of power systems for 10,000 UPSs and 23,000 DC systems (© of NTT Facilities) [47].

In telecom and data centers, DC distribution systems are more reliable than conventional AC systems despite the fact that the components experience higher electrical stresses [49]. The reason behind this higher reliability is the reduction in the number of conversion stages used in these systems. The authors of [24] mention that data centers with 380Vdc distribution are 1000% more reliable due to the elimination of the extra conversion stages. A study performed on applying 380 Vdc distribution to a 5MW data center of Intel JFSI module C in Hillsboro, found that the reliability of the system using 380 Vdc were higher compared to an AC tier IV distribution [24].

6. Cost

DC distribution systems cost less than AC distribution systems. Using higher DC voltage levels further reduces the system costs and improves the system efficiency, thus reducing the operational costs of the system. Power electronic converters add up to being a major component of the system cost. The

reduction in the number of conversion stages using a high voltage DC system eliminates the need for these converters, which greatly reduces the system costs [50]. Moreover, smaller floor space is required as number of conversion stages are reduced, which further reduces the cost. On the other hand, higher voltages require elaborate protection schemes with costly fusing, wiring, and non-standard connectors that can offset the cost savings. Furthermore, the component costs can also add up to the overall system costs, for e.g., the system would now require expensive capacitors with higher voltage ratings. Thus, these design factors can cause some offset of the savings.

With an increase in voltage level, the amount of copper required to limit the copper losses decreases. This is inversely proportional to the square of the voltage. The authors in reference [51] compare the copper cable required for a power transmission of 100 kW in 48 Vdc and 400 Vdc. They conclude that the 400 Vdc requires 10 times less copper than the 48 Vdc, making it less costly. Also, the cabling and installation costs are reduced as the smaller conductors used are more flexible and easier to lay.

According to reference [24], a 380 Vdc system, compared to an AC system, requires 15% less initial capital cost due to the reduced power conversion and 33% less floor space, which contributes to the reduced cost; it also has a 36% lower lifetime cost. Conductor costs in distribution systems can be 10–15% of the total hardware cost and increasing the DC bus voltage level can represent less than 5% savings in the total hardware costs [31]. In reference [31], it has been shown that the cost of a 270 Vdc system is 15% lower than that of a 48 Vdc system. The cost breakdown for a 30 kW, 270 Vdc, and a 48 Vdc system is shown in Figure 8. It is shown that, due to the lower number of conversion stages, the equipment cost is lower for the 270 Vdc system. The cabling cost is also lower compared to a 48 Vdc systems since smaller diameter wires are used. On the other hand, the battery cost is higher for a 270 Vdc system since more cells are connected in series.

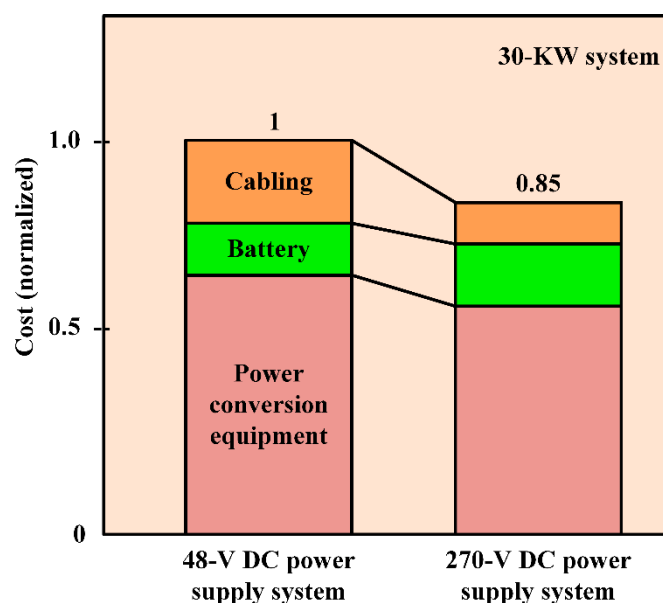

Figure 8. Cost breakdown of 48 Vdc and 270 Vdc systems.

7. Voltage Level Selection

The voltage level of DC distribution system should be selected to maximize the system efficiency and reliability, while reducing system costs and increasing the flexibility of the system for future expansion. The voltage drop and power loss [52] in a DC line can be calculated using Equations (5) and (6). According to these equations, with line resistance and power requirement being constant, the

only way to achieve a smaller voltage drop and power loss is by selecting a higher DC voltage for the distribution.

$$\Delta V_{dc} = 2 \times R \times \frac{P}{V_{dc}} \quad (5)$$

$$\Delta P_{dc} = 2 \times R \times \frac{P^2}{V_{dc}^2} \quad (6)$$

European telecom standard EN41003 and UL 1950 designated 60 Vdc as the maximum SELV (safety extra low voltage) limit [20,21]. For this reason, a nominal voltage of 48 Vdc has been chosen as the best choice for low-voltage distributed power system in conventional data centers and telecommunication systems. However, higher system voltages are preferred for the abovementioned factors, but there are also challenges like system safety and protection that can lead to fire hazards. Furthermore, the system reliability is affected as there is enhanced risk of component failure with the increased voltage and current stresses.

In reference [30], it has been reported that Telecom New Zealand deployed a 220 Vdc system for increased power capacity to replace the existing 50 Vdc system. The installed system has reportedly reduced the installation and copper costs, uses 30–40% smaller batteries, and maximizes available floor space. In reference [35], for a 220 Vac single-phase system or 380 Vac three-phase system, the DC bus voltage is chosen to be ± 110 Vdc with mid-point grounding. The DC bus voltages are selected such that the existing electric appliances can be used in the proposed system with few or no modifications. In reference [36], (DC)²TM concept has been introduced for DC integrated data centers, which have higher system efficiency and reliability compared to conventional AC distribution systems. This concept involves enhancing the operational availability of the data centers with the backup provided by using different distributed energy sources and energy storage systems. The distribution bus voltage of the proposed system is in the range of 500–550 Vdc and has increased system reliability with the integration of the distributed energy sources. Furthermore, it has been reported that the improvement in the system efficiency decreases the power required for the cooling systems, which results in a 21% savings in total energy consumption compared to AC systems.

8. Global Market for DC Distribution Systems

The only existing DC distribution implementations, until the last decade, were telecommunication and data centers operating at -48 Vdc. Research initiatives on high-tech buildings like telecommunication and data centers began in the early 2000s as a result of energy issues in California. The LBNL started looking into the efficiency of power distribution in data centers in 2004. A 380 Vdc distribution system was set up for demonstration in Newark, CA. Later, in its 2008 report, it reported an improvement in efficiency of 28% and 7%, respectively, compared to 208 Vac and 408 Vac systems in data centers [20,24]. By 2009, new facilities with DC distribution were already being implemented and studied globally, with voltage levels varying between 220 Vdc to 550 Vdc. By the end of 2014, there were more facilities implementing DC distribution at a voltage level of 380 Vdc [53–57]. As shown in Figure 9, it can be observed that the telecom and data center industry is converging at 380 Vdc as the voltage level suitable for DC distribution [47,53–56]. As of 2014, several facilities with high voltage DC systems have been established around the globe and are listed in Table 4.

The growing number of demonstration sites and early adopters indicates a growing interest in 380 Vdc distribution. Many industry standard bodies like the European Telecommunications Standard Institute (ETSI), the Alliance for Telecommunications Industry Solutions (ATIS), the International Telecommunications Union (ITU), eMerge Alliance, the International Electrotechnical Commission (IEC), Underwriters Laboratories (UL), and many others have released standards and are currently working on more in 380 Vdc distribution [53–56]. The standards released by 2014 are listed in Table 5. These standards are related to the power supply interface, DC UPS, DC equipment installation and grounding, safety, and component connectors. Currently, more research is underway on standardizing 380 Vdc distribution. Many companies have already released products compatible with 380/400 Vdc

distribution into the market. A list of companies providing components for 380 Vdc distribution is given in Table 6. Many more companies are showing interest in 380 Vdc and announcing products for the future.

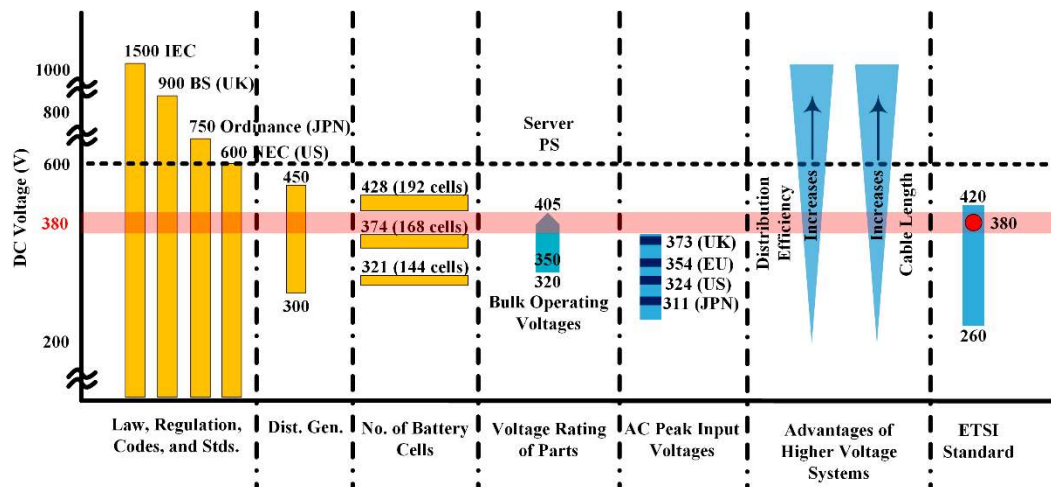

Figure 9. DC bus voltage level selection [47].

Table 4. Global DC distribution systems [53].

Year	Country	Organization	Voltage Level
2009	United States	Intel Corporation	400 Vdc
		University of California, San Diego (UCSD)	380 Vdc
		Validus (ABB)	550 Vdc
	France	France Telecom	350 Vdc
	Sweden	UPN AB.	350 Vdc
	Japan	NTT group	380/400 Vdc
	New Zealand	Telecom NZ	220 Vdc
2014	United States	SAP	
		Intel Corporation	
		Stanford University	
		IO	
		University of California, San Diego (UCSD)	
		Duke Energy	
		Clustered Systems	
		NEXTEK	
		IBM	
		Validus (ABB)	
		Syracuse University	380 Vdc
		Steel Ocr	
		North America Telecom	
		Canada Telecom Operator	
		France Telecom	
		Green.Ch, ABB	
India	IBM		
Taiwan	Taiwan IT		
Singapore	IBM		
China	China Mobile		
New Zealand	Telecom NZ		
Japan	NTT Group	380/400 Vdc	
Norway	UPN AB	350/380 Vdc	
Sweden	Netpower Labs AB	350/380 Vdc	
Korea	-	300/380 Vdc	
China	China Telecom	240/380 Vdc	

Table 5. Existing DC distribution standards [53–55].

Standard	Description
ETSI EN 300 132-3	Power supply interface at the input to telecommunications equipment
ETSI EN 301 605	Earthing and bonding of 400 Vdc data and telecom (ICT) equipment
ITU-T L.1200	Direct current power feeding interface up to 400 Vdc at the input to telecommunication and ICT equipment
YD/T 2378-2011	240 Vdc power supply system for telecommunications
Emerge Alliance Data/Telecom Center Standard	Creates an integrated, open platform for power, infrastructure, peripheral device and control applications to facilitate the hybrid use of AC and DC power within data centers and telecommunications central offices
IEC 61984	Connectors—Safety requirements and tests
UL 1977	Components connectors for use in data, signal, control, and power applications
IEC 60950	Information technology equipment—Safety
UL 60950	Safety for information technology equipment
IEC 60644-1	Insulation coordination for equipment within low-voltage systems
IEC/TC 64	Electrical installations and protection against electric shock
UL 62040-5	DC UPS standard

Table 6. Companies providing 400 Vdc products.

Product	Manufacturers
DC power system	Emerson, ABB, Delta, Netpower Labs, Eltek, Rectifier Technologies Ltd. (Australia), Japanese vendors, Chinese vendors
DC Breaker	ABB, Carling, Schneider, Nader, Siemens
Bus way	Starline, PDI, Eaton
Rack PDU	Server Tech, API Tech, Delta, Fujitsu Components, Echola
Connectors	Anderson, Hubbel, Rong Feng/Delta, Fujitsu Components
Rack-Mount Power Supply	Emerson, Delta, AcBel, others
Power Components	Vicor
ICT Load	HP, IBM, Juniper, NEL, NEC, Supermico

9. Conclusions

DC distribution systems have many inherent advantages over AC distribution like improved efficiency and reliability, easier integration of renewable energy sources and energy storage systems, and reduced costs. Moreover, DC systems have no reactive power and frequency stabilization issues, which result in reduced copper losses. Many loads like consumer electronics, light-emitting diode (LED) lighting systems, appliances using variable speed motor drives, etc., require DC power. Currently, major applications of DC distribution systems are in the fields of telecommunication systems, data centers, DC buildings, and microgrids.

In the current scenario, new facilities are being deployed with DC distribution worldwide due to its many advantages. 380 Vdc is the accepted voltage level among all the organizations establishing facilities with DC distribution due to its high efficiency, reliability, and reduced copper costs. The high efficiency of DC distribution is mainly attributed to the reduced number of power conversion stages. Furthermore, radial bus structure is more suitable for residential buildings due to the low cost and low reliability requirements. In mission-critical facilities like data centers and telecom centers, where the reliability requirements are high, a ladder or meshed bus structure is preferred. Mid-point, high-resistance grounding has been recommended as the best grounding method for DC distribution systems as it limits the fault current to harmless levels.

Various industry standard bodies like ATIS, ETSI, SCTE, eMerge Alliance, ITU-T, IEC, UL, NEC, and NEMA have been working on standards relating to 380 Vdc. A few industry standards have already been established and some are still under development. Many companies like HP, Starline, GVA Lighting, Emerson, ABB, Schneider, etc., have started providing products used in 380 Vdc systems. With growing market applications and new industry standards under development, 380 Vdc is gaining popularity among telecom and data centers. In the future, 380 Vdc might also be used for residential and commercial buildings on a larger scale.

Author Contributions: Since this is a review paper, each author was equally responsible for gathering the information. Each author was assigned with the task of putting together multiple sections. All authors contributed to the writing, review, and editing of the paper. Supervision and overseeing of the progress of the paper was carried out by V.A.P.

Conflicts of Interest: The authors declare no conflicts of interest.

References

1. Edison, T.A. System of Electrical Distribution. U.S. Patent 274,290, 28 August 1883.
2. Sprague, F.J. System of Electrical Distribution. U.S. Patent 335,045, 26 January 1886.
3. Pratt, A.; Kumar, P. Evaluation of direct current distribution in data centers to improve energy efficiency. *Data Center J.* **2007**, *28*. Available online: <https://pdfs.semanticscholar.org/7b81/222bc622c1fdf0847a708d97368d5c8da35e.pdf> (accessed on 11 August 2018).
4. Pratt, A.; Kumar, P.; Aldridge, T.V. Evaluation of 400V DC distribution in telco and data centers to improve energy efficiency. In Proceedings of the IEEE 29th International Telecommunications Energy Conference (INTELEC), Rome, Italy, 30 September–4 October 2007; pp. 32–39.
5. Liu, Y.; Pratt, A.; Kumar, P.; Xu, M.; Lee, F.C. 390V Input VRM for High Efficiency Server Power Architecture. In Proceedings of the IEEE 22nd Applied Power Electronics Conference (APEC), Anaheim, CA, USA, 25 February–1 March 2007; pp. 1619–1624.
6. Dehbonei, H.; Lee, S.R.; Nehrir, H. Direct Energy Transfer for High Efficiency Photovoltaic Energy Systems Part I: Concepts and Hypothesis. *IEEE Trans. Aerosp. Electron. Syst.* **2009**, *45*, 31–45. [[CrossRef](#)]
7. Dehbonei, H.; Lee, S.R.; Ko, S.H. Direct Energy Transfer for High Efficiency Photovoltaic Energy Systems Part II: Experimental Evaluations. *IEEE Trans. Aerosp. Electron. Syst.* **2009**, *45*, 46–57. [[CrossRef](#)]
8. Leey, J.P.; Min, B.; Kim, T.-J.; Yoo, D.-W.; Yoo, J.-Y. Input-Series-Output-Parallel Connected DC/DC Converter for a Photovoltaic PCS with High Efficiency under a Wide Load Range. *J. Power Electron.* **2010**, *10*, 9–13. [[CrossRef](#)]
9. Liu, W.-S.; Chen, J.-F.; Liang, T.J.; Lin, R.L.; Liu, C.H. Analysis, Design, and Control of Bidirectional Cascoded Configuration for a Fuel Cell Hybrid Power System. *IEEE Trans. Power Electron.* **2010**, *25*, 1565–1575.
10. Gummi, K.; Ferdowsi, M. Derivation of new double-input DC–DC converters using H-Bridge cells as building blocks. In Proceedings of the IEEE 34th Industrial Electronics Conference (IECON), Orlando, FL, USA, 10–13 November 2008; pp. 2806–2811.
11. Prabhala, V.A.; Somayajula, D.; Ferdowsi, M. Power sharing in a double-input buck converter using dead-time control. In Proceedings of the IEEE Energy Conversion Congress and Exposition (ECCE), San Jose, CA, USA, 20–24 September 2009; pp. 2621–2626.
12. Prabhala, V.A.K.; Fajri, P.; Gouribhatla, V.S.P.; Baddipadiga, B.P.; Ferdowsi, M. A DC–DC Converter with High Voltage Gain and Two Input Boost Stages. *IEEE Trans. Power Electron.* **2016**, *31*, 4206–4215. [[CrossRef](#)]
13. Oliver, S. High-voltage DC distribution is key to increased system efficiency and renewable-energy opportunities. November 2012. Available online: <http://www.vicorpower.com/documents/whitepapers/wp-High-voltage-DC-Distribution.pdf> (accessed on 11 August 2018).
14. Prabhala, V.A.K.; Baddipadiga, B.P.; Ferdowsi, M. DC distribution systems—An overview. In Proceedings of the IEEE International Conference on Renewable Energy Research and Application (ICRERA), Milwaukee, WI, USA, 19–22 October 2014.
15. Kwasinski, A. Evaluation of dc Voltage Levels for Integrated Information Technology and Telecom Power Architectures. In Proceedings of the IEEE. 4th International Telecommunication—Energy Special Conference (TELESCON), Vienna, Austria, 10–13 May 2009; pp. 1–7.
16. Boroyevich, D.; Cvetkovic, I.; Dong, D.; Burgos, R.; Fei, W.; Lee, F. Future electronic power distribution systems a contemplative view. In Proceedings of the IEEE 12th International Conference on Optimization of Electrical and Electronic Equipment (OPTIM), Basov, Romania, 20–22 May 2010; pp. 1369–1380.
17. Mistry, K.M.; Silverman, E.; Taylor, T.; Willis, R. Telecommunications power architectures: Distributed or centralized. In Proceedings of the IEEE 11th International Telecommunications Energy Conference (INTELEC '89), Florence, Italy, 15–18 October 1989.
18. Margaritis, B.; Ide, P. Contemporary architectures for power systems considering future trends. In Proceedings of the IEEE 23rd International Telecommunications Energy Conference (INTELEC), Edinburgh, UK, 14–18 October 2001; pp. 525–531.
19. Cividino, L. Power system architecture's for the emerging information highway. In Proceedings of the IEEE 16th International Telecommunications Energy Conference (INTELEC'94), Vancouver, BC, USA, 30 October–3 November 1994; pp. 90–97.

20. Xu, C.D.; Cheng, K.W.E. A survey of distributed power system—AC versus DC distributed power system. In Proceedings of the IEEE 4th International Conference on Power Electronics Systems and Applications (PESA), Hong Kong, China, 8–10 June 2011; pp. 1–12.
21. Luo, S.; Batarseh, I. A review of distributed power systems part I: DC distributed power system. *IEEE Aerosp. Electron. Syst. Mag.* **2005**, *20*, 5–16. [[CrossRef](#)]
22. Tabisz, W.A.; Jovanovic, M.M.; Lee, F.C. Present and future of distributed power systems. In Proceedings of the IEEE 7th Applied Power Electronics Conference and Exposition (APEC '92), Boston, MA, USA, 23–27 February 1992; pp. 11–18.
23. Peng, W.; Goel, L.; Xiong, L.; Hoong, C.F. Harmonizing AC and DC: A Hybrid AC/DC Future Grid Solution. *IEEE Power Energy Mag.* **2013**, *11*, 76–83. [[CrossRef](#)]
24. AlLee, G.; Tschudi, W. Edison Redux: 380 Vdc Brings Reliability and Efficiency to Sustainable Data Centers. *IEEE Power Energy Mag.* **2012**, *10*, 50–59. [[CrossRef](#)]
25. Rasmussen, N.; Spitaels, J. A Quantitative Comparison of High Efficiency ac VS. Dc Power Distribution for Data Centers. APC White Paper 127. 2006. Available online: <https://www.anixter.com/content/dam/Suppliers/APC/White%20Paper/A%20Quantitative%20Comparison.pdf> (accessed on 11 August 2018).
26. Huey, P.; Lo, E.; Pong, B. DC Electrical Distribution Systems in Buildings. In Proceedings of the IEEE International Conference on Power Electronics Systems and Applications (ICPESA '06), Hong Kong, China, 12–14 November 2006; pp. 115–119.
27. Hammerstrom, D.J. AC Versus DC Distribution Systems—Did We Get it Right? In Proceedings of the Power Engineering Society General Meeting, Tampa, FL, USA, 12–14 June 2007; pp. 1–5.
28. Hirose, K.; Takeda, T.; Muroyama, S. Study on Field Demonstration of Multiple Power Quality Levels System in Sendai. In Proceedings of the IEEE 28th International Telecommunications Energy Conference (INTELEC '06), Providence, RI, USA, 10–14 September 2006; pp. 1–6.
29. Allen, W.; Natale, S.V. Achieving ultra-high system availability in a battery-less -48VDC power plant. In Proceedings of the IEEE 24th International Telecommunications Energy Conference (INTELEC), Montreal, QC, Canada, 29 September–3 October 2002; pp. 287–294.
30. Foster, C.; Dickinson, M. High voltage DC power distribution for telecommunications facilities. In Proceedings of the IEEE 30th International Telecommunications Energy Conference (INTELEC), San Diego, CA, USA, 14–18 September 2008; pp. 1–4.
31. Yamashita, T.; Muroyama, S.; Furubo, S.; Ohtsu, S. 270 V DC system—a highly efficient and reliable power supply system for both telecom and datacom systems. In Proceedings of the IEEE 21st International Telecommunication Energy Conference (INTELEC '99), Copenhagen, Denmark, 9 June 1999.
32. Carlsson, U.; Flodin, M.; Akerlund, J.; Ericsson, A. Powering the Internet—Broadband equipment in all facilities—The need for a 300 V DC powering and universal current option. In Proceedings of the IEEE 25th International Telecommunications Energy Conference (INTELEC '03), Yokohama, Japan, 23 October 2003; pp. 164–169.
33. Akerlund, J.; Gennas, C.B.A.; Ohlsson, G.; Rosin, D. One year operation of a 9 kW HVDC UPS 350 v at Gnesta municipality data center. In Proceedings of the IEEE 29th International Telecommunications Energy Conference (INTELEC), Rome, Italy, 30 September–4 October 2007; pp. 40–45.
34. Engelen, K.; Shun, E.L.; Vermeyen, P.; Pardon, I.; D'Hulst, R.; Driesen, J. The Feasibility of Small-Scale Residential DC Distribution Systems. In Proceedings of the IEEE Conference on Industrial Electronics (IECON), Paris, French, 6–10 November 2006; pp. 2618–2623.
35. Lee, P.W.; Lee, Y.Z.; Lin, B.T. Power distribution systems for future homes. In Proceedings of the IEEE International Conference on Power Electronics and Drive Systems (PEDS '99), Hong Kong, China, 27–29 July 1999; Volume 2, pp. 1140–1146.
36. Gross, P.; Godrich, K.L. Total DC Integrated Data Centers. In Proceedings of the IEEE 27th International Telecommunications Conference (INTELEC '05), Berlin, Germany, 18–22 September 2005; pp. 125–130.
37. Hirose, K.; Tanaka, T.; Babasaki, T.; Person, S.; Foucault, O.; Sonnenberg, B.J. Grounding concept considerations and recommendations for 400VDC distribution system. In Proceedings of the IEEE 33rd International Telecommunications Energy Conference (INTELEC), Amsterdam, The Netherlands, 9–13 October 2011; pp. 1–8.

38. Seungseok, B.; Yuba, T.; Kiryu, K.; Nakamura, A.; Miyazawa, H.; Noritake, M. Development of plug and socket-outlet for 400 volts direct current distribution system. In Proceedings of the IEEE 8th International conference on Power Electronics and ECCE Asia (ICPE & ECCE), Jeju, Korea, 30 May–3 June 2011; pp. 218–222.
39. Noritake, M.; Iino, T.; Fukui, A.; Hirose, K.; Yamasaki, M. A study of the safety of the DC 400 V distribution system. In Proceedings of the IEEE 31st International Telecommunications Energy Conference (INTELEC), Incheon, Korea, 18–22 October 2009; pp. 1–6.
40. Hirose, K. DC power demonstrations in Japan. In Proceedings of the IEEE 8th International Conference on Power Electronics and ECCE Asia (ICPE & ECCE), Jeju, Korea, 30 May–3 June 2011; pp. 242–247.
41. Hernandez, J.C.; Vidal, P.G.; Medina, A. Characterization of the insulation and leakage currents of PV generators: Relevance for human safety. *Renew. Energy* **2010**, *35*, 593–601. [[CrossRef](#)]
42. Hernandez, J.C.; Vidal, P.G. Analysis of PV Generator Insulation and Leakage Currents. Relevance for Personal Safety. In Proceedings of the 19th European Photovoltaic Solar Energy Conference, Paris, French, 7–11 June 2004; pp. 2587–2590.
43. Medina, A.; Hernandez, J.C.; Ortega, M.J.; Jurado, F. DC current injection into the network from transformerless and LF transformer photovoltaic inverters. In Proceedings of the 16th International Conference on Harmonics and Quality of Power (ICHQP), Bucharest, Romania, 25–28 May 2014.
44. Hernandez, J.C.; Sutil, F.S.; Vidal, P.G. Protection of a multiterminal DC compact node feeding electric vehicles on electric railway systems, secondary distribution networks, and PV systems. *Turkish J. Elect. Eng. Comput. Sci.* **2016**, *24*, 3123–3143. [[CrossRef](#)]
45. Carling, I. Technologies (2015)—DC Circuit Breaker. Available online: http://www.carlingtech.com/sites/default/files/documents/CX-Series_Details_%26_COS_010714.pdf (accessed on 11 August 2018).
46. Inttpat, P.; Paisuwanna, P.; Khomfoi, S. Capacitor lifetime monitoring for multilevel modular capacitor clamped DC to DC converter. In Proceedings of the IEEE 8th International Conference on Electrical Engineering/Electronics, Computer, Telecommunications and Information Technology (ECTI-CON), Khon Kaen, Thailand, 17–19 May 2011; pp. 719–722.
47. Becker, D.J.; Sonnenberg, B.J. DC microgrids in buildings and data centers. In Proceedings of the IEEE 33rd International Telecommunications Energy Conference (INTELEC), Amsterdam, The Netherlands, 9–13 October 2011; pp. 1–7.
48. Talapko, D. Telecom datacenter power infrastructure availability comparison of DC and AC UPS. In Proceedings of the IEEE International Telecommunications Energy Conference (INTELEC), Scottsdale, AZ, USA, 30 September–4 October 2012.
49. Sithimolada, V.; Sauer, P.W. Facility-level DC vs. typical ac distribution for data centers: A comparative reliability study. In Proceedings of the IEEE Region 10 Conference (TENCON), Fukuoka, Japan, 21–24 November 2010.
50. Bodi, F.; Hui, L.E. 380/400V DC powering option. In Proceedings of the IEEE 33rd International Telecommunications Energy Conference (INTELEC), Amsterdam, The Netherlands, 9–13 October 2011; pp. 1–8.
51. Matsumoto, A.; Fukui, A.; Takeda, T.; Hirose, K.; Yamasaki, M. Development of 400 Vdc power distribution system and 400 Vdc output rectifier. In Proceedings of the IEEE 31st International Telecommunications Energy Conference (INTELEC), Incheon, Korea, 18–22 October 2009; pp. 1–5.
52. Sannino, A.; Postiglione, G.; Bollen, M.H.J. Feasibility of a DC network for commercial facilities. *IEEE Trans. Ind. Appl.* **2003**, *39*, 1499–1507. [[CrossRef](#)]
53. Patterson, B. DC Power Distribution Systems. 25 February 2015. Available online: http://www.emergealliance.org/Portals/_default/Knowledgebase/1/150225%20Strategies%20in%20Light_The%20LED%20Show_BTP.pdf (accessed on 11 August 2018).
54. Patterson, B.; Hamborsky, D. Net Zero Strategies for Existing Buildings. 21 June 2013. Available online: http://emergealliance.org/Portals/_default/Knowledgebase/1/NetZeroStrategiesforExistingBuildings_21421_1.pdf (accessed on 11 August 2018).
55. Patterson, B.; Symanski, D. The Nation’s Quest for Net Zero Energy Buildings: DC Distribution—The Power to Change Buildings. Lawrence Berkeley National Labs Seminar, 14 July 2011. Available online: http://portal.emergealliance.org/DesktopModules/Inventure_Document/FileDownload.aspx?ContentID=20624 (accessed on 11 August 2018).

56. Boeke, U.; Wendt, M. DC power grids for buildings. In Proceedings of the IEEE First International Conference on DC Microgrids (ICDCM), Atlanta, GA, USA, 24–27 May 2015; pp. 210–214.
57. Vossos, V.; Garbesi, K.; Shen, H. Energy Savings from Direct-DC in U.S. Residential Buildings. *Energy Build.* **2014**, *68*, 223–231. [[CrossRef](#)]



© 2018 by the authors. Licensee MDPI, Basel, Switzerland. This article is an open access article distributed under the terms and conditions of the Creative Commons Attribution (CC BY) license (<http://creativecommons.org/licenses/by/4.0/>).