

# An Overview of the AC-DC and DC-DC Converters for LED Lighting Applications

DOI 10.7305/automatika.53-2.154  
UDK 621.32.032.3:621.38  
IFAC 4.6.2

Original scientific paper

High-Brightness Light Emitting Diodes (HB-LEDs) are considered the future trend in lighting not only due to their high efficiency and high reliability, but also due to their other outstanding characteristics: chromatic variety, shock and vibration resistance, etc. Nevertheless, they need the development of new power supplies especially designed for boosting and taking advantage of their aforementioned characteristics. Besides, their behaviour is completely different from the rest of lighting devices and, consequently, it should be also taken into account in the design of the converters used to drive them. As a result, many well-known topologies have been optimized or redesigned in order to be used in LED-lighting applications and many new topologies have come up in the recent years with the same purpose.

In this paper, the main HB-LED characteristics will be explained, highlighting how they influence the design of their power supplies. After, the main topologies will be presented from the simplest to the most complex ones, analysing their advantages and disadvantages.

**Key words:** AC-DC converters, DC-DC converters, LED, Lighting

**Pregled AC-DC i DC-DC pretvarača za primjene u LED rasvjeti.** Svjetleće diode s visokom razinom svjetline (HB-LED) smatraju se budućim trendom u rasvjeti zahvaljujući ne samo visokom stupnju efikasnosti i pouzdanosti, nego i njihovim izvanrednim svojstvima: raznolikost boja, otpornost na udarce i vibracije i sl. Ipak, s ciljem potpunog iskorištenja prethodno spomenutih svojstava, potrebno je razviti nove, posebno osmišljene izvore napajanja. Osim toga, ponašanje im se posve razlikuje od ostalih tipova rasvjete što je potrebno uzeti u obzir pri projektiranju pretvarača za njihovo napajanje. Kao posljedica toga, mnoge su poznate topologije pretvarača optimirane ili preoblikovane posebno za primjenu u LED rasvjeti, a zadnjih nekoliko godina mnoge nove su se tek pojavile.

U ovom članku objašnjena su osnovna HB-LED svojstva naglašavajući njihov utjecaj na razvoj izvora napajanja. Uz to, prikazane su osnovne topologije, od najjednostavnijih do najsloženijih, ujedno analizirajući prednosti i nedostatke pojedinih.

**Ključne riječi:** AC-DC pretvarači, DC-DC pretvarači, LED, rasvjeta

## 1 INTRODUCTION

High-Brightness Light Emitting Diodes (HB-LEDs) are spreading over all lighting applications (vehicles lights, home and street lighting, traffic and commercial signs, etc.). In fact, they are considered as the future trend in lighting due to their outstanding advantages [1-3]:

- Their theoretical luminous efficacy is the highest. In fact, right now they have the highest real efficacy (around 150 lm/W) only exceeded by low-pressure sodium technology (around 190 lm/W).
- Their lifetime is very long, around 50,000 hours depending on the driving technique, operating temperature, etc.

- They are environmentally friendly, as they are produced without mercury.
- They are based on semiconductors. Therefore, they are resistant to shock and vibrations.
- They have wide chromatic variety.
- They are easily turn-on and turn-off, which allows their use in intelligent lighting.

Nevertheless, it has to be taken into account that LED drivers cannot be as simple as those of the incandescent lamps. It is mandatory to develop new drivers specifically designed for these lighting devices due to two reasons:

- Because the demands of LEDs regarding voltage and current are completely different from the rest of lighting devices. HB-LEDs have a nominal DC current which may vary from 100 mA to 1 or 2 A (a very common value is 350 mA). Regarding the voltage, it depends on the number of LEDs connected in series, but the standard knee voltage of these devices is around 3-4 V. Depending on the number of LEDs supplied by the driver and their specific way of association (see later), the output voltage of the driver may be as high as 140 V or as low as 12 V. Regarding the output current of the driver, it may be as low as 350 mA or as high as 5 A.
- Because the drivers should have the same advantages as HB-LEDs have. As a consequence, the design should aim at high efficiency and high reliability as primary concerns [4]. As a consequence, a very common requirement imposed to these drivers is the absence of electrolytic capacitor in order to boost reliability and achieving a lifetime around 10 years [5, 6]. As will be seen, this strongly determines the possible topologies that may be valid in AC-DC applications.

In this paper, a review of the main topologies for driving LEDs is going to be presented. In Section 2, some specific details regarding HB-LEDs will be presented (driving techniques, arrangements, etc.). In Section 3, the topologies for supplying the LEDs from a DC source will be presented. In Section 4, the topologies for using AC sources will be explained and, finally in Section 5, a brief summary will be presented.

## 2 DRIVING TECHNIQUES, FLICKERING AND LED ARRANGEMENTS

Before presenting a classification of the converters suitable to drive HB-LEDs, a brief explanation regarding flickering, driving techniques and LED arrangements should be given.

HB-LEDs can be defined as fast lighting devices. This means that the amount of light emitted by an LED is, to some extent, nearly proportional to the current which is driving with a very fast dynamic response. The main disadvantage of this is that if the current driven by the LED is affected by a low frequency ripple, this ripple is not going to be filtered by the LED device and is going to affect the emitted light too. This leads to the very well-known problem of flickering [7, 8]. Therefore, special efforts have to be made in order to supply LEDs with a current free of ripple under 400 Hz.

This fast response also has an advantage. The amount of light emitted by an LED depends on the average value

of the supplied current while the temperature of the emitted light depends on the peak value of the supplied current. In order to control the amount of light emitted by the LED, two dimming techniques are then possible (see Fig. 1) [9, 10]:

- Analog dimming: the LED is supplied with a DC current whose value will depend on the amount of light that is desired. Its main disadvantage is that this variation in the current not only controls the amount of light, it also affects the temperature of the light (i.e.: the peak value coincides with the average value).
- PWM dimming: the LED is supplied with a relatively-high-frequency (a few kHz) PWM-controlled current with a certain peak value and a certain duty cycle. In this way, the amount of light is controlled by the average value of the PWM current (i.e.: by the duty cycle) while the temperature of the light is defined by its peak value. This PWM current needs to have a frequency higher than 400 Hz so that it is filtered by the human eye and flickering is not a problem.

Regarding the possible LED arrangements [11, 12], a given number of LEDs can be connected in several ways as already mentioned (Fig. 2). If all the LEDs are connected in series (LED string), the main problem is that the failure of just one LED may affect the whole string if the LED fails in open circuit. If the same number of LEDs is connected as several strings in parallel, the main problem is that a way of equalizing the current [13] through each string has to be used (i.e.: connecting all the strings to the same voltage without equalization, as shown in Fig. 2, may lead to different currents in some strings due to differences in their characteristics).

## 3 DC-DC TOPOLOGIES

### 3.1 Topologies without galvanic isolation

#### 3.1.1 Passive topologies

The easiest way of supplying an LED arrangement from a DC source is using a resistor for limiting the current driven by the LEDs (Fig. 3a). The calculation of this resistor should take into account the high value of HB-LED knee voltage. Although it is the cheapest and simplest solution, efficiency is very poor and the output current is unregulated. Therefore, it will be affected by variations in the input voltage and it is only useful in very low-power applications, such as flashlights.

This solution may be also used as equalizing method (Fig. 3b) when the LED arrangement includes several LED strings in parallel (i.e.: each string has its own equalizing

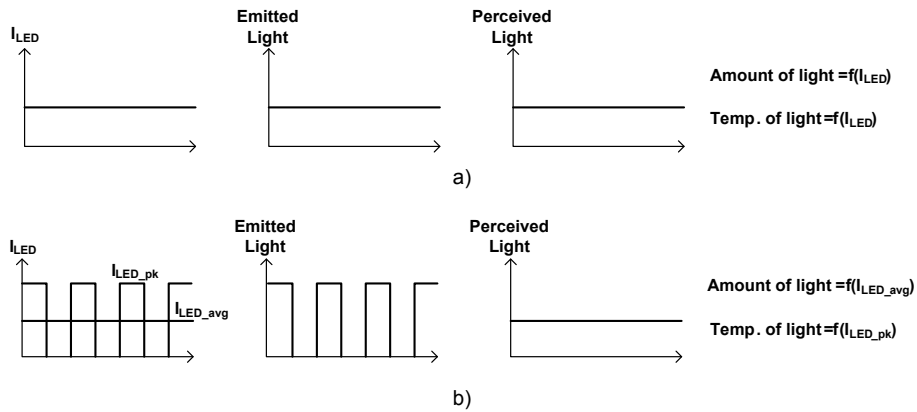

Fig. 1. a) Analog and b) PWM dimming techniques for obtaining the same amount of emitted and perceived light

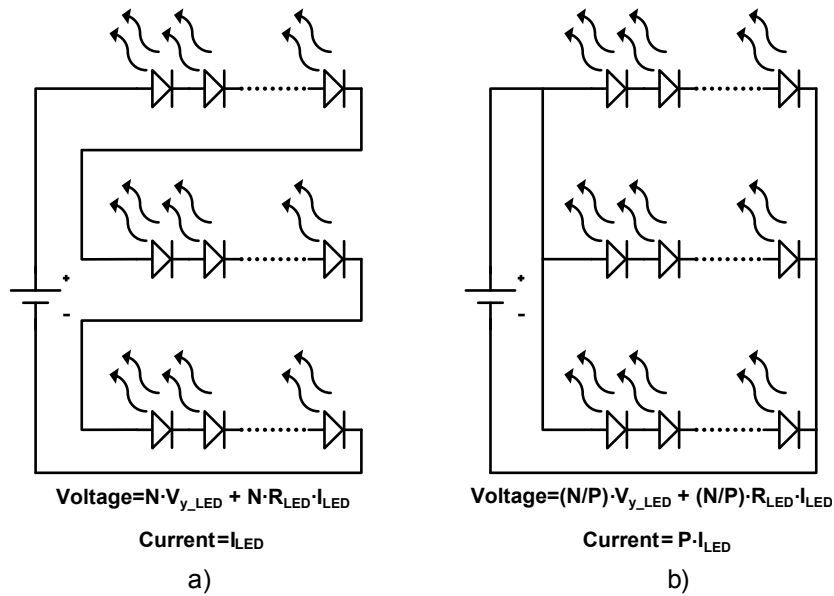

Fig. 2. Different LED-arrangement configurations (equalizers not shown in the second arrangement). a)  $N$  LEDs in a single string; b)  $N$  LEDs in  $P$  strings.

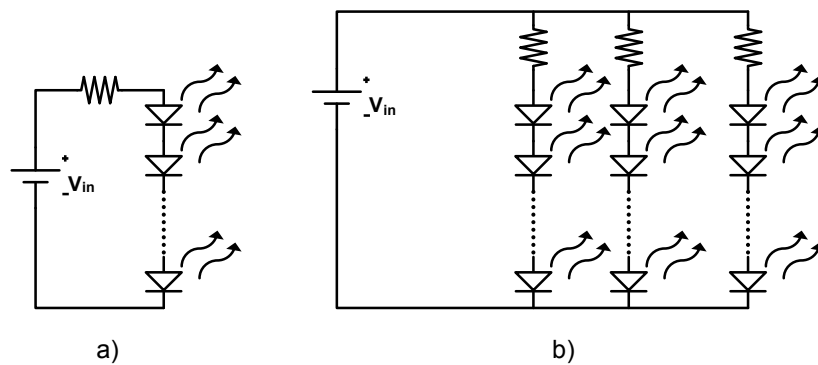

Fig. 3. a) DC-DC passive solution for driving a single LED string; b) The same passive solution for equalizing the current of several LED strings in parallel

resistor). Considering that in this case the voltage applied to the LED arrangement is regulated (it will be explained later), the difference between the applied voltage and the nominal voltage of the strings will be very small and the losses in the resistors will also be very small. Nevertheless, this is only used as equalizing technique in very cheap solutions.

**3.1.2 Active topologies**

**Linear regulator**

If the resistor is replaced with a linear regulator, the current supplied to the LEDs will be constant and independent from the input voltage (as shown in Fig. 4). Nevertheless, the transistor of the linear regulator behaves as a current source whose value depends on the control loop (i.e.: the transistor is not turning on and off as in switching mode power supplies). Therefore, efficiency is still a problem, especially when there is a big difference between the voltage of the DC source  $V_{in}$  and the voltage demanded by the LED arrangement  $V_{LED}$ . This technique is commonly used as an equalizer due to its simplicity [12, 14, 15].

**One-stage switching topologies**

It is possible to replace the linear regulator with a switching mode power supply (see Fig. 5) in order to regulate the output current/voltage without power dissipation (ideally). This solves the problem of the previous circuits regarding the efficiency. In this way, efficiency is boosted without losing the LED arrangement current regulation. Obviously, the cost and size of this solution is higher than the cost of the previous ones, but it can be disregarded if the improvement in efficiency is considered.

As the input voltage is DC, there is not going to be any problem with reliability: the output filter of the DC-DC converter does not have to filter any other frequency different from the switching frequency, so it can be implemented

without electrolytic capacitors which, as has been already mentioned, have a lifetime considerably shorter than HB-LEDs.

If the LED arrangement includes several strings in parallel, it is possible to use one DC-DC converter for the whole LED arrangement and an equalizer (as presented before) for each string. Efficiency is going to be slightly affected. Nevertheless, it should be taken into account that the converter is regulated and, therefore, the voltage applied to the arrangement is going to be very close to the nominal voltage of the strings. Consequently, the voltage difference absorbed by the resistors/linear regulators in order to equalize the currents is very small, leading to small power dissipation. Another option is using one converter for each string. Although efficiency is not affected, it implies a considerable increase in cost and size.

The possible topologies (Fig. 6) that can be used as on-stage solutions for LED lighting will depend on the input and output voltage values [16]. If the output voltage is higher than the input one, the boost converter [17, 18] is the most common and the simplest topology that can be used. Nevertheless, some start-up problems due to high inrush currents may appear and some additional circuitry may be needed in order to deal with these problems. If the output voltage is lower, then the buck topology is the most suitable one. If the output voltage, due to regulation, can be higher or lower than the input voltage, then the buck-boost topology [19] is the recommended one. Of course, there are other topologies that can be used, such as the SEPIC [20] or Ćuk [21] topology.

**Two-stage switching topologies**

In DC-DC LED-lighting applications, the two stage topology makes sense only when the input voltage has a wide range of variation. In that case, the purpose of the first stage is supplying a constant DC voltage to the second stages, as many as LED strings in parallel, which are

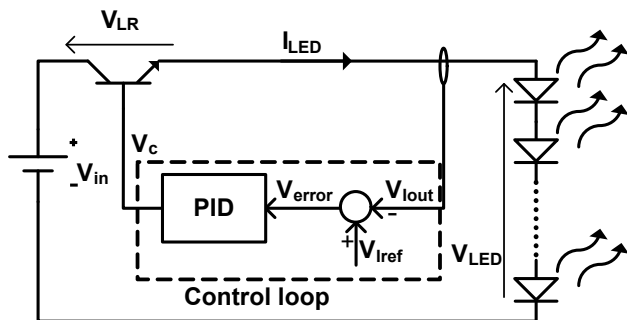

Fig. 4. DC-DC active solution with a linear regulator

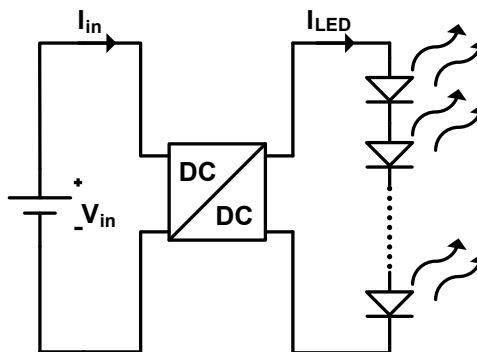

Fig. 5. DC-DC one-stage active topology

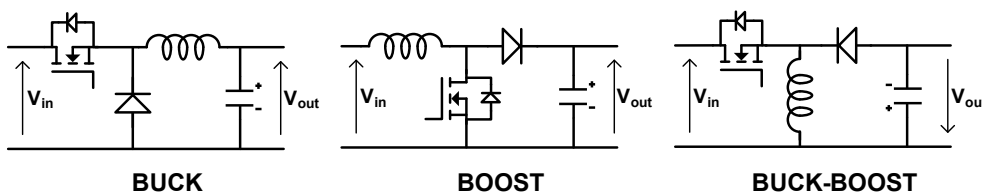

Fig. 6. Most common non-isolated DC-DC topologies. The buck and the buck-boost topologies can be modified for HB-LEDs applications so that their MOSFET is referred to ground.

in charge of precisely regulating the LED string current (Fig. 7). The cost and size are higher than in the one-stage topology with equalizer resistors (or linear-regulator equalizers) but its efficiency is not compromised.

The same topologies presented for the one-stage solution can be used in the two-stage solution. The main issue is that, normally, the second stages used as equalizers are buck converters. Hence, the output voltage of the first stage should be a little bit higher than the nominal voltage of the LED strings.

### 3.2 Topologies with galvanic isolation

In this Section, only active topologies are going to be presented because the galvanic isolation implies the use of a transformer. This transformer cannot operate from DC voltages and, therefore, it is necessary an active component in order to keep the average value of the voltage applied to the transformer equal to zero (for avoiding its saturation). Besides, the use of isolated topologies makes sense only when the input voltage is high or when the galvanic isolation is a normative (or customer) requirement.

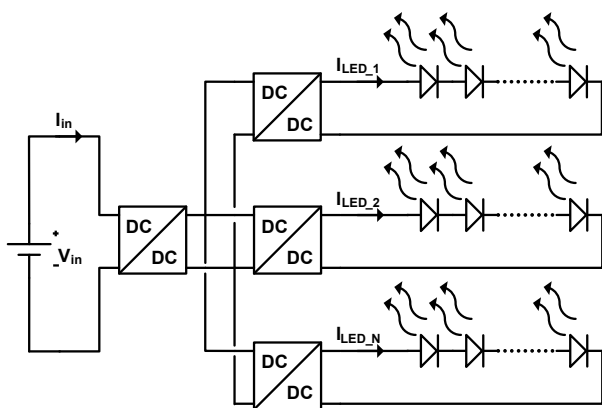

Fig. 7. DC-DC two-stage active solution. Second stages work as equalizers of the current.

#### 3.2.1 Active topologies

##### One-stage switching topologies

The same advantages and disadvantages mentioned for the one-stage topology without galvanic isolation can be considered for the one with galvanic isolation (Fig. 8). The main difference is that the chosen topology has to include a transformer. Considering that the switching frequency of these converters is around tens or hundreds of kHz, the size of the transformer is not big (compared to the size of a line-frequency transformer).

An additional advantage is that it is possible to use a transformer with several secondary windings. As a consequence, several output voltages can be obtained, even with different voltage and current specifications in order to supply, at the same time, different LED strings of a given arrangement. Nevertheless, the independent regulation of each output cannot be reached. Only one output would be regulated and the rest will have a fixed ratio with the regulated one. Therefore, equalizing techniques are still mandatory if several LED strings of an arrangement are going to be supplied with the same multiple-output converter. Moreover, another option for several LED strings in parallel may be using as many converters as LED strings. Nevertheless, this would lead to having as many transformers as LED strings. Due to the cost of these components, it may be a very expensive solution when many strings are placed in parallel.

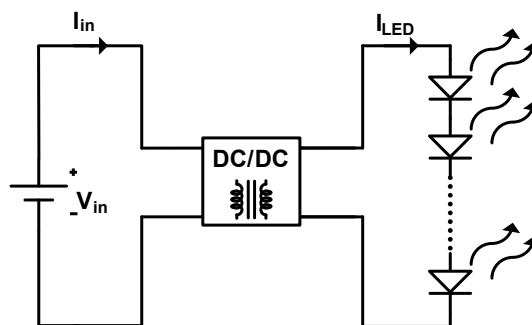

Fig. 8. DC-DC one-stage active topology with galvanic isolation

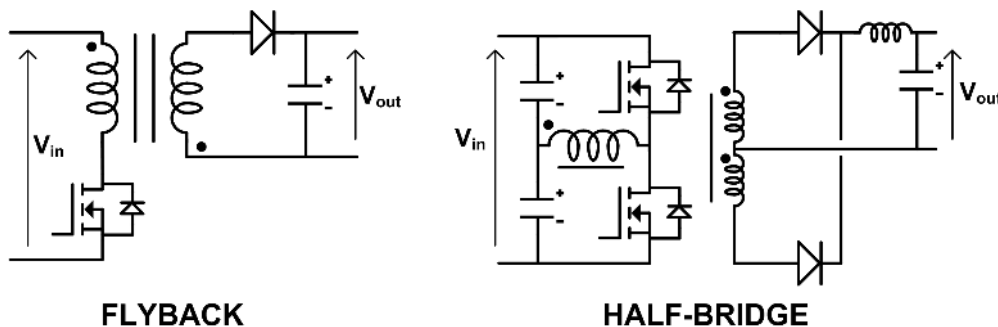

Fig. 9. Examples of typical isolated topologies

Traditional converter topologies (Fig. 9) for this kind of application are the flyback family (isolated SEPIC, Ćuk and Zeta) [22-24], the Half-Bridge (HB) (including the asymmetrically driven one) [25-29] and the Push-Pull [16].

**Two-stage switching topologies**

Considering that not only current regulation, but also galvanic isolation are requirements, the two-stage solution may be considered for driving LED arrangements of several LED strings in parallel (Fig. 10). Transformers are bulky and expensive components; therefore, galvanic isolation should be included in the first stage (which is common to all the strings) so only one transformer is needed. Second stages, one for each string, can be implemented without galvanic isolation and with the only purpose of regulating the current of each string.

For the first stage, any of the previously-mentioned isolated topologies can be used. For the second stages, the most common option is the buck converter modified in order to have the transistor source terminal referred to ground.

**4 AC-DC TOPOLOGIES**

The main feature of the topologies presented in this Section is that they are directly connected to line. Therefore, Power Factor (PF) correction [30, 31] may have to be taken into account in the driver design if the handled power is high enough. Apart from that, a classification tree can be considered again attending to two criteria: galvanic isolation and passive/active topologies.

**4.1 Topologies without galvanic isolation**

**4.1.1 Passive topologies**

If PF correction is not necessary and the required output voltage is not very high (few LEDs in series), it is possible to use a topology as simple as the one shown in Fig. 11a

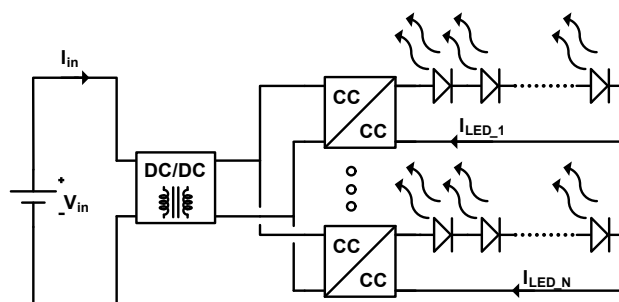

Fig. 10. DC-DC two-stage active solution with galvanic isolation

[32]. The voltage at the output of the four-diode rectifier is very small in comparison to the line voltage due to the voltage drop across the series capacitor  $C_s$  and, therefore, the current supplied to the LEDs is limited. The main advantages of this topology are cost, size and simplicity. Obviously, this solution is only valid when PF correction is not mandatory (input current has a  $90^\circ$  phase-lead) and when performance is not the main issue. Besides, there is a start-up problem with this topology: if the zener diode  $DZ$  and the resistor  $R$  are not included in the design, the LED arrangement is going to withstand the instantaneous line voltage in the moment in which the circuit is connected to the grid and until the capacitor is charged. This may lead to LED break down due to excessive voltage.

It should be taken into account that there is no active current regulation and the quality of the light is very poor. In fact, the current through the LEDs is not constant. It has a rectified-sinusoidal pattern at twice the line frequency and, therefore, flickering will be a problem due to the fast response of LEDs. Nevertheless, this can be solved by placing a bulk capacitor  $C_p$  in parallel to the LED arrangement so that the rectified-sinusoidal pattern is filtered and the supplied current to the arrangement is, to some extent, constant (Fig. 11b). Besides, both topologies present a hazardous situation: when they are disconnected from the line,

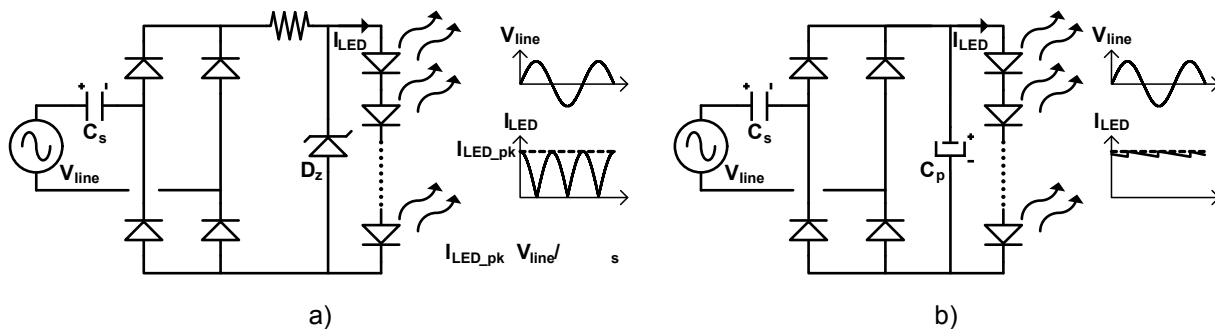

Fig. 11. AC-DC passive solution for driving LED arrangements

the input capacitor  $C_s$  remains charged so its contacts represent a risk for human operators. Due to this, a resistor must be placed in parallel with  $C_s$  so that it can be discharged.

If PF correction is mandatory, a possible passive topology is presented in [33]. Nevertheless, its main drawback is the use of low-frequency inductors, which implies high size and cost even for low-power applications. Besides, three diodes are needed (apart from the rectifier bridge ones). Although they do not need any kind of controller, their number of semiconductors is similar to the one corresponding to active topologies.

4.1.2 Active topologies

One-stage switching topologies

One-stage switching topologies may be seen as an evolution of the previous topology in order to solve some of its problems. The first possibility is shown in Fig. 12. Instead of using a capacitor for limiting the maximum current driven by the LEDs, it may be possible to use a DC-DC converter in cascade with the rectifier in order to keep

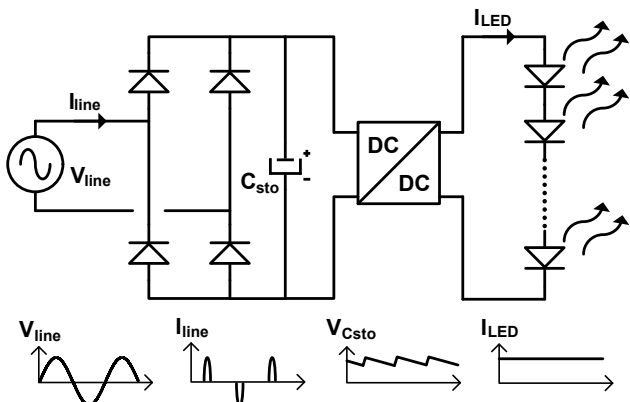

Fig. 12. One stage AC-DC active solution

constant the current supplied to the load. Obviously, a capacitor between both is necessary in order to have available energy during the periods of time in which the line voltage is close to zero. With this solution, the current (voltage) supplied to the lighting device is constant and flickering is no longer a problem. Besides, the energy storage is carried out at high voltage (peak value of the line voltage); in practice that means that the size of the capacitor is going to be smaller. This is a key point because it makes possible the use of non-electrolytic capacitors, enlarging the lifetime of the topology. Nevertheless, there is no possibility of doing PF correction if constant current is supplied by the converter to the LEDs. Therefore, this solution does not comply with ENERGYSTAR or IEC61000-3-2 Class C regulations and its field of application is limited.

It is possible to change the situation of the storage capacitor from the input to the output of the converter (see Fig. 13a). In this way, PF correction can be achieved (the converter is a Power Factor Corrector or PFC) while keeping a constant current at the output of the converter (see Fig. 13b). As it can be seen, the output current is sensed and compared to the reference  $V_{Iref}$ . The resulting control signal is multiplied by a half-sinusoidal reference (in this case, the rectified input voltage), and the output of the multiplier is the reference for the input current feedback loop. In this way, the input current has a sinusoidal pattern synchronized with the line voltage while the output current has the desired value. Nevertheless, placing the storage capacitor at the output implies that the energy is stored at a voltage equal to the one demanded by the LED string. Normally, the LED arrangement is implemented in such a way that the output voltage is going to be lower than the peak value of the input voltage. Therefore, for the same amount of stored energy, the capacitance needed by this solution is higher than in the previous one (in which energy is stored at the input of the converter). Moreover, the size of the resulting capacitor is going to be bigger although it is rated for a lower voltage. The main consequence is that, in a real design, the capacitor has to be an

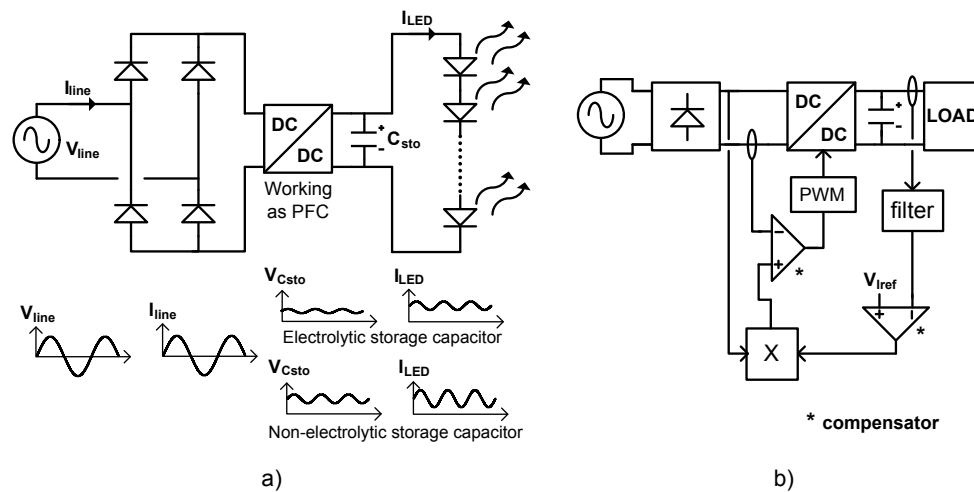

Fig. 13. a) One-stage AC-DC active solution with PFC; b) Simplified block diagram of the control of a PFC when the output current is controlled (instead of the output voltage)

electrolytic one and the lifetime of the converter is compromised. If non-electrolytic capacitors were used, the capacitance that could be achieved at the output of the converter using reasonable space would lead to a considerable low-frequency voltage ripple [34]. Considering the electric model of the LEDs, this would imply even a higher relative current ripple and, consequently, non admissible flickering in the emitted light. Of course, if the LEDs are arranged in such a way that the required output voltage is similar to the peak value of the input voltage or even higher, this problem is mitigated. Nevertheless, this is not always possible as some customers' requirements limit the output voltage of this kind of applications to 60 V due to hazardous voltage limit.

Apart from what has been explained, it should be taken into account that the one stage topology is a cost and volume saving solution while keeping precise regulation of the output current and other control advantages (short-circuit protection, dimming, etc.). Moreover, its efficiency may be high as only one energy conversion is carried out.

Finally, one stage topologies supplying several strings connected in parallel can solve the problem mentioned in Section 2 in two different ways: equalizers can be connected to each string or each string can be supplied by its own converter. With the first option, cost is not significantly increased, but efficiency is going to decrease due to the poor efficiency of the equalizer. With the second option, efficiency is not affected, but cost and size are significantly increased although each converter is not designed for the nominal power, but for the LED string power.

There are some topologies that are valid for one-stage solutions. If PF correction is not mandatory, it is possible to have the energy storage capacitor at the input. Consid-

ering that the voltage demanded by the LED arrangement is normally lower than the peak value of the input voltage, the buck converter may be valid. If PF correction is mandatory, the buck [35] (only with very low output voltages) or the buck-boost topology operating in Discontinuous Conduction Mode (DCM) are a perfect option. Besides, if the LED arrangement requires an input voltage higher than the peak value of the input voltage, the boost converter [36-38] operating in Boundary Conduction Mode (BCM) may be selected. As it was mentioned, some start-up problem may appear with this topology due to high inrush currents. The Conduction Modes (CM) may be defined attending to the current through the inductor of the converter (see Fig. 14) [16]. If the inductor current does not reach zero, the converter is operating in Continuous CM (CCM). If the current reaches zero and remains with that value for a while, the converter is operating in DCM. If the current rises again as soon as it reaches zero, the converter is operating in Boundary CM (BCM).

### Two-stage switching topologies

As can be seen, the main problem of the previous topology was trying to achieve PF correction and current regulation with just one converter. The main consequence was the mandatory use of electrolytic capacitor, compromising reliability, or (if it is not used) having an excessive low-frequency current ripple (i.e.: flickering). This can be solved if a two stage topology is used as shown in Fig. 15.

The first stage of this two-stage topology would be in charge of performing the PF correction. As this topology is not directly connected to the LEDs, its output voltage can be as high as needed. Therefore, the energy can be stored



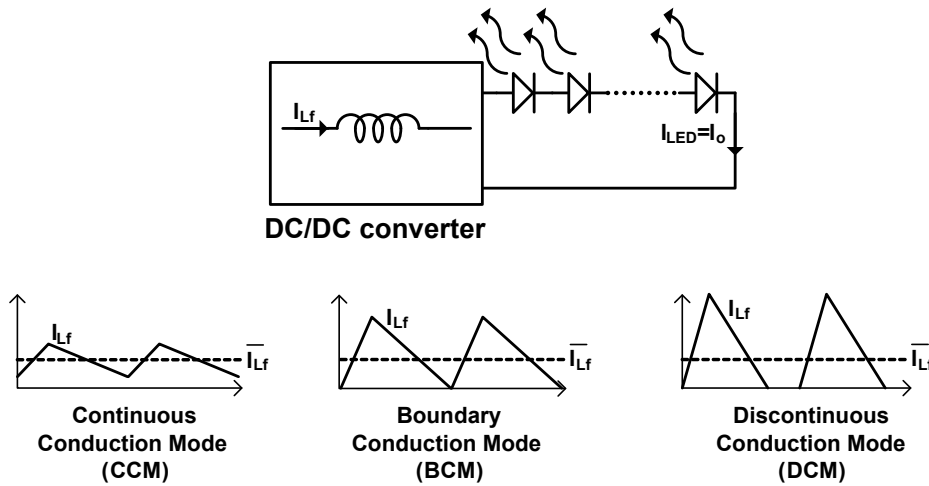

Fig. 14. Continuous, Boundary and Discontinuous Conduction Mode as a function of the inductor current of the output filter

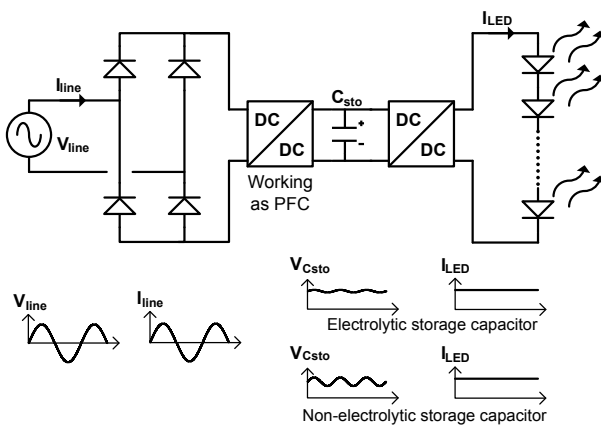

Fig. 15. Two-stage AC-DC active solution

at the output of this converter with non-electrolytic capacitors. Moreover, any low-frequency ripple in this output voltage will not necessarily affect the LEDs because it can be cancelled by the second stage. Therefore, the amount of energy that is stored can be reduced, which means that the capacitance can be lower and, consequently, the size of the capacitor will be smaller.

The second stage is in charge of regulating the current driven by LEDs. That means that it also has to cancel any low-frequency ripple present at its input voltage as it has been mentioned. Therefore, the output filter can be calculated for filtering only the switching frequency, which means small-size inductors and capacitors. Besides, due to the value of the first stage output voltage, this second stage is usually implemented with step-down topologies.

As it can be seen, one of the main advantages of this topology is reliability. It can be easily implemented with-

out electrolytic capacitors, so its lifetime is considerably enlarged.

The main disadvantages of this topology are the high number of components and its size. This increases the cost and, as a consequence, they are not usually used for cost-effective solutions, such as replacement LED-based light bulbs, in which cost and size are the key points.

It may seem that efficiency is another disadvantage: as two energy conversions are carried out, its efficiency should be lower than the efficiency of one-stage topologies. Nevertheless, in the two-stage topology, each converter is optimized for just one task. As a consequence, they can reach very high efficiency and, in fact, the overall efficiency is usually higher than in the case of the one-stage topology (which cannot be optimized and, consequently, its efficiency is compromised).

If the LED arrangement includes several strings connected in parallel, it is possible to use equalizers in each string with the corresponding efficiency decrease. Another option is keeping the first stage common to all the LED strings and having as many second stages as LED strings in the arrangement. Cost and size are going to be increased, but it should be taken into account that only the second stages are duplicated, not the first one.

As first stage, and considering that galvanic isolation is not required in any of the stages, the boost converter is the most suitable option. The PF correction can be achieved in two possible ways:

- Operating in BCM (see Fig. 14). The switching frequency is then variable (which implies a little bit more complex input EMI filter) but switching losses in the output diode are considerably reduced and efficiency may reach very high values (around 97%).

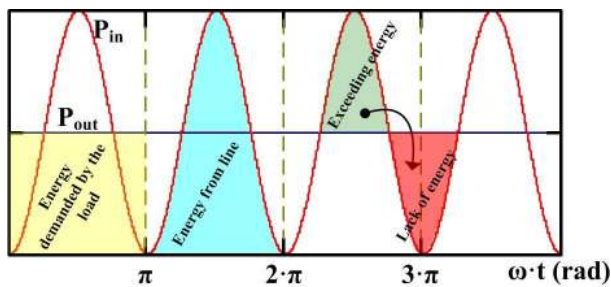

Fig. 16. Energy balance of a PFC converter

- Operating in CCM (see Fig. 14). The switching frequency is constant but a controller with a multiplier is required for the PF correction. Besides, the switching losses in the diode are not reduced and alternative methods are required if efficiency needs to be boosted (e.g.: the use of Silicon Carbide Schottky diodes instead of Silicon diodes [39]).

The second stage, as has been said, is usually implemented with step-down converters, such as the buck converter.

### Special two-stage switching topologies

Lately, an intermediate solution between the one and two stage topologies has been proposed [40, 41]. As can be seen in Fig. 16, when the first converter achieves PF correction, the amount of energy obtained from the line (blue area) is equal to the amount of energy demanded by the load (yellow area). Nevertheless, there is a mismatch between the instantaneous power available at the input and the instantaneous power demanded by the load. Therefore, the exceeding energy (green area) needs to be stored in order to be used when there is a lack of it (red area). In the previous solutions, the energy is directly stored in the output capacitor of the PF correction converter. In this intermediate solution (Fig. 17), the LED arrangement is directly fed by the PFC converter. Nevertheless, when there is an excess of energy in its output, this excess is stored by an auxiliary converter in the storage capacitor. When there is a lack of energy, this auxiliary converter extracts this energy from the storage capacitor and injects it into the load. Hence, the output capacitor of the PFC converter is no longer the storage capacitor and, consequently, it may be small (in size and capacitance) [42].

As can be seen, this topology tries to keep the advantages of both, the one-stage and the two-stage topology, while alleviating their drawbacks. The exceeding energy is the only one to be processed several times (once by the PFC and twice by the auxiliary converter). That means that

68% of the total energy is processed only once (like in the one-stage solution). Hence, efficiency should be boosted. Besides, the output capacitor is not the storage capacitor and, consequently, electrolytic-free topologies can be implemented.

Although it may seem attractive at first glance, it should be taken into account that it has two important disadvantages. The auxiliary converter has to be bidirectional, so that energy can flow from  $C_{sto}$  to the load or from the PFC converter to  $C_{sto}$ . This adds complexity to the topology. Besides, the control algorithm of the whole system is quite complex as there are several variables to be controlled: input current, output current and storage capacitor voltage (i.e.: energy flux).

In practice, the PFC converter can be any of the ones proposed for the one stage solution. For the auxiliary converter, the most suitable option is a bidirectional boost converter (operates as a buck converter when energy flows in the opposite direction).

## 4.2 Topologies with galvanic isolation

### 4.2.1 Passive topologies

For obtaining galvanic isolation, it is possible to modify the solution proposed in Fig. 11 by adding a transformer as shown in Fig. 18. The capacitor for limiting the current can be eliminated because the turns ratio ( $n:1$ ) of the transformer can reduce the voltage applied to the LED arrangement. To the disadvantages explained in 3.1.1, it should be added here that a low-frequency transformer is needed. Even for the lowest power, the topology is relatively bulky due to the low-frequency transformer.

### 4.2.2 Active topologies

The active solutions, when galvanic isolation is required, have the possibility of using converters in which the transformer is inside the aforementioned converter. Therefore, high-frequency (hundreds of kHz) transformer can be used, saving size and cost. Taking this into account, using a non-isolated converter in combination with a low-frequency transformer is not considered as an option due to its inherent disadvantages. As in the previous Section, one-stage and two stage solutions can be presented.

### One-stage switching topologies

Apart from other tasks, the converter used as single stage has to provide galvanic isolation. That means the use of a transformer that implies additional advantages and disadvantages to those presented in 4.1.2. If PF correction is not mandatory, a one-stage topology similar to the one presented in Fig. 12 can be used (with the storage capacitor

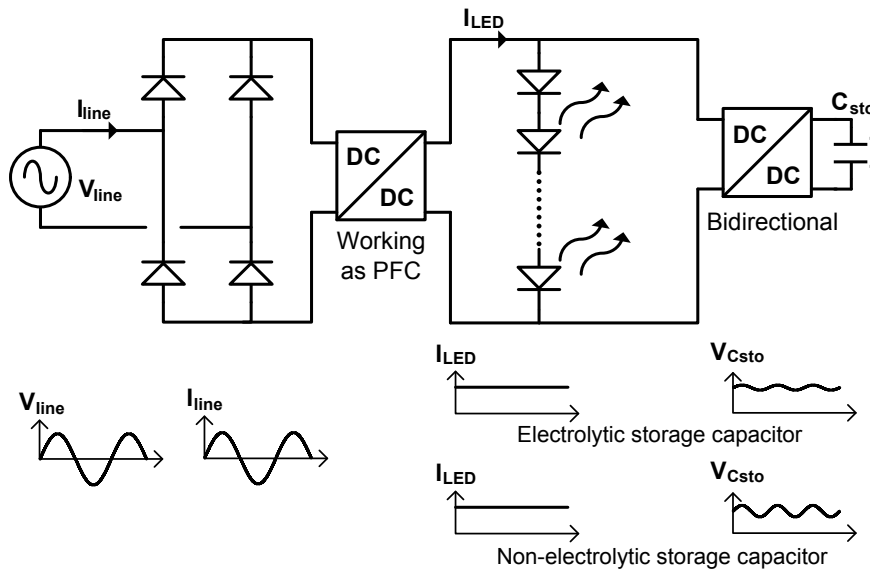

Fig. 17. Special two-stage topology with bidirectional auxiliary converter

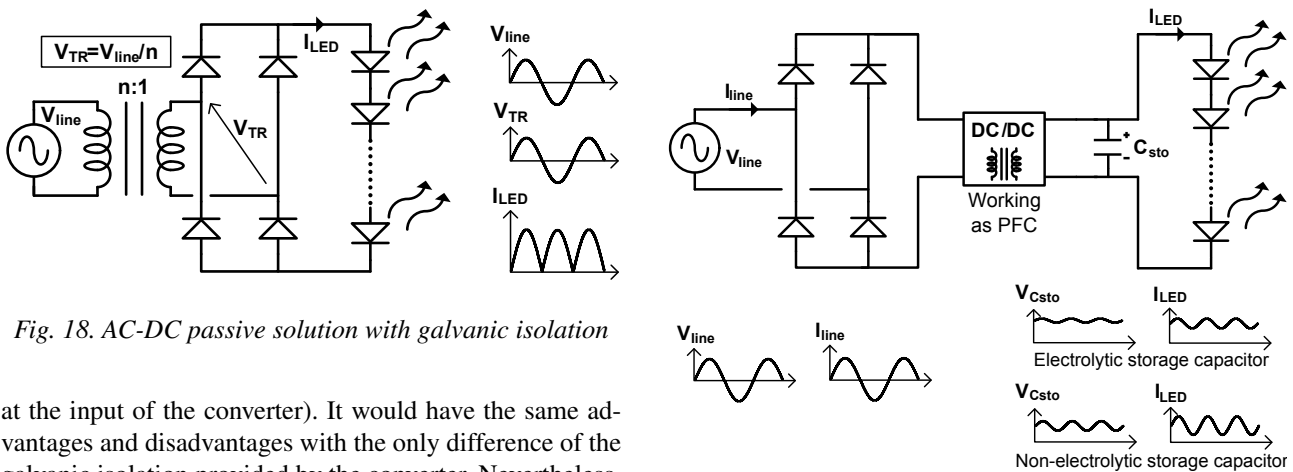

Fig. 18. AC-DC passive solution with galvanic isolation

Fig. 19. One-stage AC-DC active solution with galvanic isolation

at the input of the converter). It would have the same advantages and disadvantages with the only difference of the galvanic isolation provided by the converter. Nevertheless, achieving PF correction is a very common requirement and the most common topology is the one presented in Fig. 19, in which the storage capacitor is at the output of the converter.

First of all, it should be considered that if there is a big difference between the input and the output voltages, semiconductors of a non-isolated topology (e.g.: buck, boost, etc.) are going to withstand very high voltages and high peak currents. Therefore, the overall efficiency is going to be compromised due to their worse performance and characteristics (e.g.: RDSON, knee voltage, dynamic resistance, etc.). Using isolated converters reduces the voltage and current stress on semiconductors and, therefore, increases the overall efficiency. Hence, the isolated topologies may be the most suitable option if there is a big difference between the input and the output voltage even when galvanic isolation is not required.

Another advantage is that it is possible to use a transformer with several secondary windings, as mentioned in 3.2.1. As in that case, several outputs can be obtained in order to supply several LED strings. Nevertheless, equalizing techniques are still mandatory due to the impossibility of independently regulate each output. It has been also already mentioned that using one galvanic-isolated converter for supplying each LED strings implies too many transformers taking into account the cost and size of this kind of magnetic components.

One of the main disadvantages apart from the cost and size of the transformers is that the reliability problem still exists: the output capacitor has to be an electrolytic one,

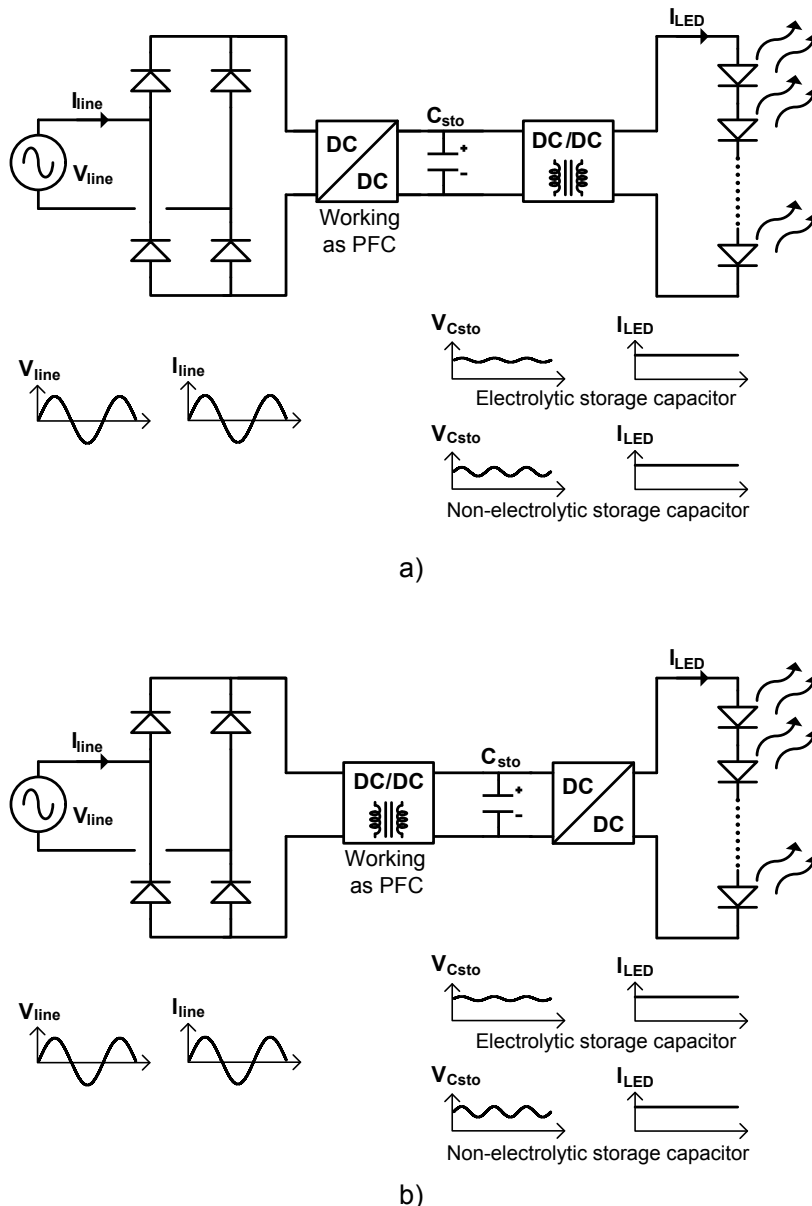

Fig. 20. Two-stage active solution with galvanic isolation in the a) second stage b) first stage

especially if the output voltage is relatively low.

The most common topology used when galvanic isolation is required is the flyback topology working as PFC. In fact, any topology of the flyback family (isolated SEPIC, Ćuk, etc.) [43-49] may be valid with identical results and only some differences in the input EMI filter.

**Two-stage switching topologies**

The key issue in this topology is deciding where to place the galvanic isolation. It should be taken into account that the higher the output voltage of the PFC con-

verter, the smaller the actual size of the storage capacitor. Besides, the voltage demanded by the LED arrangements is usually considerably smaller than the peak value of the line voltage. Therefore, using an isolated second stage (see Fig. 20a) allows us to maintain a high voltage in the storage capacitor of the PFC converter (intermediate DC bus) while having a high efficiency in the second stage even with low output voltages (i.e.: big differences between its input and output voltages).

Nevertheless, if the LED arrangement includes several LED strings in parallel and each one is going to be connected to its own second stage (while the first one is com-

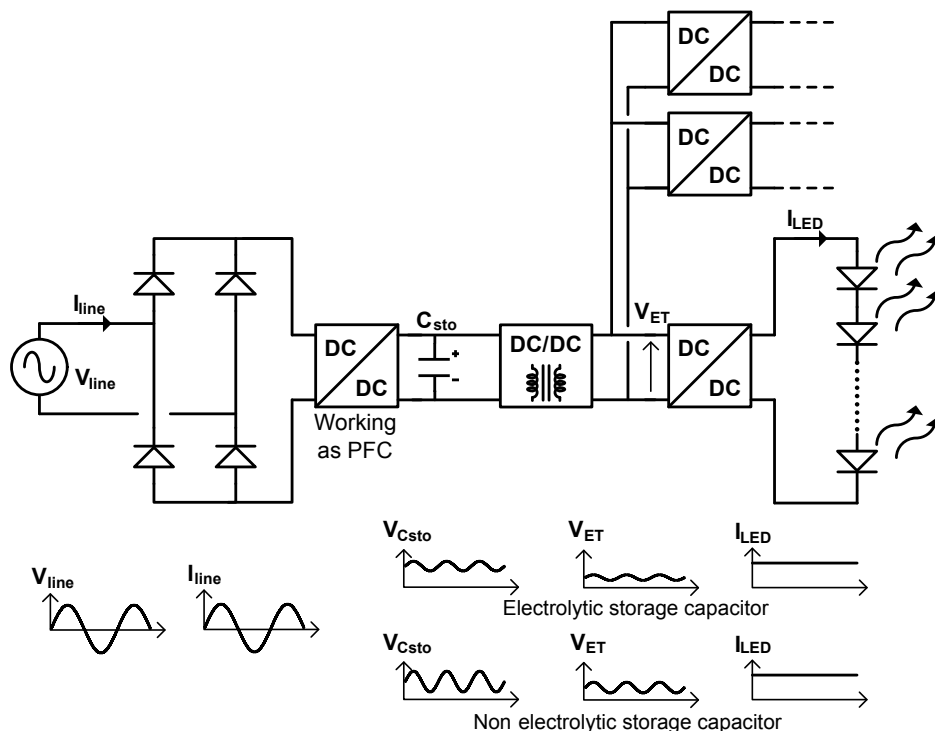

Fig. 21. Three-stage AC-DC active solution with galvanic isolation

mon to all the LED strings), it should be taken into account that placing the galvanic isolation in the first stage (see Fig. 20b) may mean a considerable saving in cost and size, although current ripple and reliability may be compromised.

The most common topology for the first stage, if galvanic isolation is achieved by means of the second stage, is the boost converter (as explained in 3.1.2) [50]. If galvanic isolation is achieved in the first stage, flyback family converters [45, 46] are the most suitable option. Common isolated second stages are HB LLC resonant converter [51-54], Asymmetrical HB (AHB) [55, 56], flyback family [50, 57, 58], etc. Non-isolated topologies for the second stage are buck [59], TIBuck [60-65] (taking advantage of the possibility of two isolated outputs in the first stage) or any other non-isolated topology.

**Three-stage switching topologies**

When several LED strings are connected in parallel and galvanic isolation is mandatory, the second stage can evolve into a three-stage topology as the one shown in Fig. 21. The idea is that each stage is responsible for just one task [54, 59]. In this way, the first stage would provide the PF correction, the second stage would provide the galvanic isolation and the third stage would regulate the output current. The main advantage of this topology is that the

first and the second stages are common to all the strings, while there are as many third stages as strings in parallel. Therefore, the topology has only one transformer (there is only one second stage) and the cost is not significantly increased. It may be considered as a two-stage topology with equalizers, but it has two important differences with it:

- The equalizers have poor efficiency in comparison to the third stages proposed here. They are switching mode power supplies with very high efficiency.
- The second stage in this topology only provides the galvanic isolation and does not have to regulate the output current. Therefore, this second stage can be unregulated and, consequently, being based on the Electronic Transformer (ET) concept [66], which may reach an efficiency as high as 97%-98%. It should be taken into account that the ET may be considered as a transformer that can operate with DC voltages. Therefore, although it is unregulated, it can apply a fixed gain (turns ratio in a real transformer) to its input voltage. In the two-stage topology with several second stages, these second stages have to provide the galvanic isolation and they also have to regulate the output current. As they have to accomplish two different tasks, their optimization is worse.

## 5 CONCLUSION

LED represents a very interesting alternative to the traditional lighting devices due to, among other reasons, their high efficiency and reliability. Nevertheless, they need the development of converters specially designed for taking advantage of their characteristics. This implies the design of converters with very high efficiency and without electrolytic capacitor so that their lifetime is extended. Although for DC-DC converters this is not a big problem, for AC-DC topologies (when PFC is mandatory) this means a big design-effort. Besides, the control technique for regulating the amount of light emitted by the LED may benefit from its fast response. Therefore, it is very important to know all the possible topologies, their advantages and disadvantages, in order to choose the best option for each situation: street lighting, flashlights, car lights, advertising signs, etc.

## ACKNOWLEDGEMENT

This work has been supported by Spanish Government under projects RUE-10-CSD2009-00046 FEDER Funds, MICINN10-DPI2010-21110-C02-01 and student grant FPI BES-2011-044114.

## REFERENCES

- [1] X. Long, R. Liao, and J. Zhou, "Development of street lighting system-based novel high-brightness LED modules," *Optoelectronics, IET*, vol. 3, pp. 40-46, 2009.
- [2] B. Lehman and A. Shteynberg, "Professional Education Seminars: LED lighting: trends, standards, optics and power electronics," presented at Applied Power Electronics Conference and Exposition (APEC), Fort Worth, 2011.  
C. Van Dam, "Efficient Power Solutions for LED Lighting Installations," *Bodo's Power Systems*, pp. 54-55, 2011.  
D. Bailey, "An Idea to Simplify LED Lighting Purchase Decisions," *Bodo's Power*, pp. 18, 2011.
- [3] W. Beibei, R. Xinbo, Y. Kai, and X. Ming, "A Method of Reducing the Peak-to-Average Ratio of LED Current for Electrolytic Capacitor-Less AC-DC Drivers," *Power Electronics, IEEE Transactions on*, vol. 25, pp. 592-601, 2010.
- [4] G. Linlin, R. Xinbo, X. Ming, and Y. Kai, "Means of Eliminating Electrolytic Capacitor in AC/DC Power Supplies for LED Lightings," *Power Electronics, IEEE Transactions on*, vol. 24, pp. 1399-1408, 2009.
- [5] A. Wilkins, J. Veitch, and B. Lehman, "LED lighting flicker and potential health concerns: IEEE standard PAR1789 update," presented at Energy Conversion Congress and Exposition (ECCE), 2010 IEEE, 2010.
- [6] B. Lehman, A. Wilkins, S. Berman, M. Poplawski, and N. Johnson Miller, "Proposing measures of flicker in the low frequencies for lighting applications," presented at Energy Conversion Congress and Exposition (ECCE), 2011 IEEE, 2011.
- [7] T. Siew-Chong, "Level Driving Approach for Improving Electrical-to-Optical Energy-Conversion Efficiency of Fast-Response Saturable Lighting Devices," *Industrial Electronics, IEEE Transactions on*, vol. 57, pp. 1342-1353, 2010.
- [8] L. Wai-Keung, K. H. Loo, T. Siew-Chong, Y. M. Lai, and C. K. Tse, "Bilevel Current Driving Technique for LEDs," *Power Electronics, IEEE Transactions on*, vol. 24, pp. 2920-2932, 2009.
- [9] B. A. Thomas, "Edison revisited: Impact of DC distribution on the cost of LED lighting and distributed generation," presented at Applied Power Electronics Conference and Exposition (APEC), 2010 Twenty-Fifth Annual IEEE.
- [10] P. S. Almeida, J. M. Jorge, C. R. B. S. Rodrigues, G. M. Soares, D. P. Pinto, and H. A. C. Braga, "A novel method of current equalization in LED strings based on simple linear circuit," presented at Industrial Electronics (ISIE), 2011 IEEE International Symposium on.
- [11] J. Wang, J. Zhang, X. Wu, Y. Shi, and Z. Qian, "A novel high efficiency and low-cost current balancing method for multi-LED driver," presented at Energy Conversion Congress and Exposition (ECCE), 2011 IEEE, 2011.
- [12] H. Yuequan and M. M. Jovanovic, "LED Driver With Self-Adaptive Drive Voltage," *Power Electronics, IEEE Transactions on*, vol. 23, pp. 3116-3125, 2008.
- [13] C. Huang-Jen, L. Yu-Kang, C. Jun-Ting, C. Shih-Jen, L. Chung-Yi, and M. Shann-Chyi, "A High-Efficiency Dimmable LED Driver for Low-Power Lighting Applications," *Industrial Electronics, IEEE Transactions on*, vol. 57, pp. 735-743, 2010.
- [14] R. Erickson and D. Maksimovic, *Fundamentals of Power Electronics*, vol. 1, 2nd ed: Kluwer academic, 1956.
- [15] C. Zheng, W. Yu, J.-S. Lai, and H. Ma, "Single-switch three-level boost converter for PWM dimming LED lighting," presented at Energy Conversion Congress and Exposition (ECCE), 2011 IEEE, 2011.
- [16] M. A. D. Costa, G. H. Costa, A. S. dos Santos, L. Schuch, and J. R. Pinheiro, "A high efficiency autonomous street lighting system based on solar energy and LEDs," presented at Power Electronics Conference, 2009. COBEP '09. Brazilian, 2009.
- [17] S. Rao, Q. Khan, S. Bang, D. Swank, A. Rao, W. McIntyre, and P. K. Hanumolu, "A 1.2A buck-boost LED driver with 13% efficiency improvement using error-averaged SenseFET-based current sensing," presented at Solid-State Circuits Conference Digest of Technical Papers (ISSCC), 2011 IEEE International.
- [18] R. P. Massey and E. C. Snyder, "High Voltage Single-Ended DC-DC Converter," presented at Power Electronics Specialist Conference. PESC 1977, Palo Alto (CA), 1977.
- [19] S. Čuk and R. D. Middlebrook, "A New Optimum Topology Switching DC-to-DC Converter," presented at Power Electronics Specialists Conference. PESC 1977, Palo Alto (CA), 1977.

- [20] R. D. Middlebrook and S. Čuk, "Isolation and Multiple Output Extensions of a New Optimum Topology Switching DC-to-DC Converter," presented at Power Electronics Specialists Conference. PESC 1978, New York (NY), 1978.
- [21] R. Erickson, M. Madigan, and S. Singer, "Design of a simple high-power-factor rectifier based on the flyback converter," presented at Applied Power Electronics Conference and Exposition, 1990. APEC '90, Conference Proceedings 1990., Fifth Annual, 1990.
- [22] L. Xingming and Z. Jing, "An intelligent driver for Light Emitting Diode Street Lighting," presented at Automation Congress, 2008. WAC 2008. World, 2008.
- [23] J. Sebastian, J. A. Cobos, O. Garcia, and J. Uceda, "An overall study of the half-bridge complementary-control DC-to-DC converter," presented at Power Electronics Specialists Conference, 1995. PESC '95 Record., 26th Annual IEEE, 1995.
- [24] R. Oruganti, H. Phua Chee, J. T. K. Guan, and C. Liew Ah, "Soft-switched DC/DC converter with PWM control," Power Electronics, IEEE Transactions on, vol. 13, pp. 102-114, 1998.
- [25] R. Miftakhutdinov, A. Nemchinov, V. Meleshin, and S. Fraidlin, "Modified asymmetrical ZVS half-bridge DC-DC converter," presented at Applied Power Electronics Conference and Exposition, 1999. APEC '99. Fourteenth Annual, 1999.
- [26] O. Garcia, J. A. Cobos, J. Uceda, and J. Sebastian, "Zero voltage switching in the PWM half bridge topology with complementary control and synchronous rectification," presented at Power Electronics Specialists Conference, 1995. PESC '95 Record., 26th Annual IEEE, 1995.
- [27] W. Eberle, H. Yongtao, L. Yan-Fei, and Y. Sheng, "An overall study of the asymmetrical half-bridge with unbalanced transformer turns under current mode control," presented at Applied Power Electronics Conference and Exposition, 2004. APEC '04. Nineteenth Annual IEEE, 2004.
- [28] M. J. Kocher and R. L. Steigerwald, "An AC to DC Converter with High Quality Input Waveforms," presented at Power Electronics Specialists Conference, Cambridge (MA), 1982.
- [29] D. G. Lamar, J. Sebastián, A. Rodríguez, M. Rodríguez, and M. M. Hernando, "A Very Simple Control Strategy for Power Factor Correctors Driving High-Brightness LEDs," Power Electronics, IEEE Transactions on, vol. 24, pp. 2032-2042, 2009.
- [30] N. O. Sokal, K. Sum, and D. C. Hamill, "A capacitor-fed, voltage-step-down, single-phase, nonisolated rectifier," presented at Applied Power Electronics Conference and Exposition, 1998. APEC '98. Conference Proceedings 1998., Thirteenth Annual, 1998.
- [31] S. Y. R. Hui, S. N. Li, X. H. Tao, W. Chen, and W. M. Ng, "A novel passive off-line light-emitting diode (LED) driver with long lifetime," presented at Applied Power Electronics Conference and Exposition (APEC), 2010 Twenty-Fifth Annual IEEE.
- [32] D. G. Lamar, J. Sebastian, M. Arias, and A. Fernandez, "Reduction of the output capacitor in Power Factor Correctors by distorting the line input current," presented at Applied Power Electronics Conference and Exposition (APEC), 2010 Twenty-Fifth Annual IEEE, 2010.
- [33] X. Qu, S. C. Wong, and C. K. Tse, "Resonance-Assisted Buck Converter for Offline Driving of Power LED Replacement Lamps," Power Electronics, IEEE Transactions on, vol. 26, pp. 532-540, 2011.
- [34] W. Jian-Min, W. Sen-Tung, J. Yanfeng, and C. Huang-Jen, "A Dual-Mode Controller for the Boost PFC Converter," Industrial Electronics, IEEE Transactions on, vol. 58, pp. 369-372, 2011.
- [35] L. Huber, J. Yungtaek, and M. M. Jovanovic, "Performance Evaluation of Bridgeless PFC Boost Rectifiers," Power Electronics, IEEE Transactions on, vol. 23, pp. 1381-1390, 2008.
- [36] L. Huber, B. T. Irving, and M. M. Jovanovic, "Open-Loop Control Methods for Interleaved DCM/CCM Boundary Boost PFC Converters," Power Electronics, IEEE Transactions on, vol. 23, pp. 1649-1657, 2008.
- [37] M. M. Hernando, A. Fernandez, J. Garcia, D. G. Lamar, and M. Rascon, "Comparing Si and SiC diode performance in commercial AC-to-DC rectifiers with power-factor correction," Industrial Electronics, IEEE Transactions on, vol. 53, pp. 705-707, 2006.
- [38] Q. Hu and R. Zane, "Off-line LED driver with bidirectional second stage for reducing energy storage," presented at Energy Conversion Congress and Exposition (ECCE), 2011 IEEE, 2011.
- [39] Q. Hu and R. Zane, "Minimizing Required Energy Storage in Off-line LED Drivers Based on Series-input Converter Modules," Power Electronics, IEEE Transactions on, vol. PP, pp. 1-1, 2010.
- [40] Y. Jiang, F. C. Lee, G. Hua, and W. Tang, "A novel single-phase power factor correction scheme," presented at Applied Power Electronics Conference and Exposition, 1993. APEC '93. Conference Proceedings 1993., Eighth Annual, 1993.
- [41] C. A. Canesin and I. Barbi, "A unity power factor multiple isolated outputs switching mode power supply using a single switch," presented at Applied Power Electronics Conference and Exposition, 1991. APEC '91. Conference Proceedings, 1991., Sixth Annual, 1991.
- [42] J. Sebastian, J. Uceda, J. A. Cobos, J. Arau, and F. Aldana, "Improving power factor correction in distributed power supply systems using PWM and ZCS-QR SEPIC topologies," presented at Power Electronics Specialists Conference, 1991. PESC '91 Record., 22nd Annual IEEE, 1991.
- [43] H. Ma, W. Yu, Q. Feng, J.-S. Lai, and C. Zheng, "A novel SEPIC-derived PFC pre-regulator without electrolytic capacitor for PWM dimming LED lighting application based on valley fill circuit," presented at Energy Conversion Congress and Exposition (ECCE), 2011 IEEE, 2011.

- [44] H. Ma, W. Yu, C. Zheng, J.-S. Lai, Q. Feng, and B.-Y. Chen, "A universal-input high-power-factor PFC preregulator without electrolytic capacitor for PWM dimming LED lighting application," presented at Energy Conversion Congress and Exposition (ECCE), 2011 IEEE, 2011.
- [45] Y. Hu, L. Huber, and M. Jovanovic, "Single-Stage, Universal-Input AC/DC LED Driver with Current-Controlled Variable PFC Boost Inductor," *Power Electronics*, IEEE Transactions on, vol. PP, pp. 1-1, 2010.
- [46] M. Brkovic and S. Čuk, "Input current shaper using Čuk converter," presented at Telecommunications Energy Conference, 1992. INTELEC '92., 14th International, 1992.
- [47] D. S. L. Simonetti, J. Sebastian, and J. Uceda, "The discontinuous conduction mode Sepic and Čuk power factor preregulators: analysis and design," *Industrial Electronics*, IEEE Transactions on, vol. 44, pp. 630-637, 1997.
- [48] K. I. Hwu, Y. T. Yau, and L. Li-Ling, "Powering LED Using High-Efficiency SR flyback Converter," *Industry Applications*, IEEE Transactions on, vol. 47, pp. 376-386, 2011.
- [49] H.-S. Choi, "AN4151. Half-bridge LLC resonant converter design using Fairchild Power Switch (FPS)," Fairchild semiconductor, 2007.
- [50] K. Bong-Chul, P. Ki-Bum, K. Chong-Eun, L. Byoung-Hee, and M. Gun-Woo, "LLC Resonant Converter With Adaptive Link-Voltage Variation for a High-Power-Density Adapter," *Power Electronics*, IEEE Transactions on, vol. 25, pp. 2248-2252.
- [51] F. Dianbo, L. Ya, F. C. Lee, and X. Ming, "A Novel Driving Scheme for Synchronous Rectifiers in LLC Resonant Converters," *Power Electronics*, IEEE Transactions on, vol. 24, pp. 1321-1329, 2009.
- [52] ST, "AN2983 Application Note," 2010.
- [53] M. Arias, D. G. Lamar, A. Vázquez, J. Sebastián, D. Balocco, and A. Diallo, "Analysis of the Asymmetrical half-bridge for Street LED-Lighting Applications," presented at Energy Conversion Congress and Exposition, ECCE 2011, Phoenix (EEUU), 2011.
- [54] M. Arias, D. Lamar, F. Linera, D. Balocco, A. Diallo, and J. Sebastian, "Design of a Soft-Switching Asymmetrical Half-Bridge Converter as second stage of a LED driver for Street-Lighting Application," *Power Electronics*, IEEE Transactions on, vol. PP, pp. 1-1, 2011.
- [55] D. Gacio, J. M. Alonso, A. J. Calleja, J. Garcia, and M. Rico-Secades, "A Universal-Input Single-Stage High-Power-Factor Power Supply for HB-LEDs Based on Integrated Buck-flyback Converter," *Industrial Electronics*, IEEE Transactions on, vol. 58, pp. 589-599, 2011.
- [56] Y. Li and C. Chen, "A Novel Single-Stage High-Power-Factor AC-to-DC LED Driving Circuit with Leakage Inductance Energy Recycling," *Industrial Electronics*, IEEE Transactions on, vol. PP, pp. 1-1, 2011.
- [57] ST, "AN3105 Application Note," ST, 2010.
- [58] J. Sebastian, P. J. Villegas, F. Nuno, and M. M. Hernando, "High-efficiency and wide-bandwidth performance obtainable from a two-input buck converter," *Power Electronics*, IEEE Transactions on, vol. 13, pp. 706-717, 1998.
- [59] J. Sebastian, P. J. Villegas, M. Hernando, F. Nuno, and F. Fernandez-Linera, "Average-current-mode control of two-input buck postregulators used in power-factor correctors," *Industrial Electronics*, IEEE Transactions on, vol. 46, pp. 569-576, 1999.
- [60] K. Gummi and M. Ferdowsi, "Double-Input DC-DC Power Electronic Converters for Electric-Drive Vehicles; Topology Exploration and Synthesis Using a Single-Pole Triple-Throw Switch," *Industrial Electronics*, IEEE Transactions on, vol. 57, pp. 617-623.
- [61] Y. Wensong, L. Jih-Sheng, M. Hongbo, and Z. Cong, "High-Efficiency DC-DC Converter With Twin Bus for Dimmable LED Lighting," *Power Electronics*, IEEE Transactions on, vol. 26, pp. 2095-2100, 2011.
- [62] J. Sebastian, P. Villegas, F. Nuno, O. Garcia, and J. Arau, "Improving dynamic response of power factor preregulators by using two-input high-efficient post-regulators," presented at Power Electronics Specialists Conference, 1996. PESC '96 Record., 27th Annual IEEE, 1996.
- [63] Y. Wensong, Z. Cong, L. Jih-Sheng, and M. Hongbo, "Single-switch three-level DC-DC converters for dimmable LED lighting," presented at Applied Power Electronics Conference and Exposition (APEC), 2011 Twenty-Sixth Annual IEEE, 2011.
- [64] R. Yuancheng, X. Ming, S. Julu, and F. C. Lee, "A family of high power density unregulated bus converters," *Power Electronics*, IEEE Transactions on, vol. 20, pp. 1045-1054, 2005.



**Manuel Arias Pérez de Azpeitia** was born in Oviedo, Spain, in 1980. He received the M. Sc. degree in electrical engineering from the University of Oviedo, Gijón, Spain in 2005 and the Ph. D. degree in the same university in 2010. Since February 2005, he has been a Researcher in the Department of Electrical and Electronic Engineering, University of Oviedo, developing electronic systems for UPSs and electronic switching power supplies. Since February 2007, he has also been an Assistant Professor of electronics in the same University. His research interests include DC-DC converters, AC-DC converters and LED lighting.



**Aitor Vazquez** was born in Oviedo, Spain, in 1984. He received the M.Sc. degree in telecommunication engineering from the University of Oviedo in 2009. He became a member of Power Supply System Group in 2010, where he is currently working toward the Ph.D. degree. His research interests include multiple input and output DC/DC conversion, power-factor corrector AC/DC converters and energy recovery systems.





**Javier Sebastián** was born in Madrid, Spain, in 1958. He received the M.Sc. degree from the Polytechnic University of Madrid, Madrid, in 1981 and the Ph.D. degree from the Universidad de Oviedo, Gijón, Spain, in 1985. He was an Assistant Professor and an Associate Professor at both the Polytechnic University of Madrid and the Universidad de Oviedo. Since 1992, he has been with the Universidad de Oviedo, where he is currently a Professor. His research interests are switching-mode power supplies, modeling of DC-to-DC converters, low-output-voltage DC-to-DC converters, and high-power-factor rectifiers.

#### **AUTHORS' ADDRESSES**

**Asst. Prof. Manuel Arias, Ph.D.**

**Aitor Vasquez, M.Sc.**

**Prof. Javier Sebastián, Ph.D**

**Electronic Power Supply Systems Group,**

**Electronic Technology Division,**

**University of Oviedo,**

**Edificio 3, Campus de Viesques s/n, 33204, Gijon, Spain**

**email: {ariasmanuel, vazquezaitor.uo, sebas}@uniovi.es**

Received: 2011-12-29

Accepted: 2012-04-04