

REVIEW/SYNTHESE

An overview of the Odin atmospheric mission

Donal Murtagh, Urban Frisk, Frank Merino, Martin Ridal, Andreas Jonsson, Jacek Stegman, Georg Witt, Patrick Eriksson, Carlos Jiménez, Gerard Megie, Jérôme de la Noë, Philippe Ricaud, Philippe Baron, Juan Ramon Pardo, Alain Hauchcorne, Edward J. Llewellyn, Douglas A. Degenstein, Richard L. Gattinger, Nicholas D. Lloyd, Wayne F.J. Evans, Ian C. McDade, Craig S. Haley, Chris Sioris, Christian von Savigny, Brian H. Solheim, John C. McConnell, Kimberly Strong, E. Harvey Richardson, Gilbert W. Leppelmeier, Erkki Kyrölä, Harri Auvinen, and Liisa Oikarinen

Received 14 November 2001. Accepted 23 November 2001. Published on the NRC Research Press Web site at <http://cjp.nrc.ca/> on 12 March 2002.

D. Murtagh. Department of Meteorology, Stockholm University, SE-10691 Stockholm, Sweden and Department of Radio and Space Science, Chalmers University of Technology, SE-41296 Göteborg, Sweden.

U. Frisk. Swedish Space Corporation, PO Box 4207, SE-17104 Solna, Sweden.

F. Merino, M. Ridal, A. Jonsson, J. Stegman, and G. Witt. Department of Meteorology, Stockholm University, SE-10691 Stockholm, Sweden.

P. Eriksson and C. Jiménez. Department of Radio and Space Science, Chalmers University of Technology, SE-41296 Göteborg, Sweden.

G. Megie. Service d'Aéronomie du CNRS, IPSL-Université Pierre et Marie Curie, F-75252 Paris, France.

J. de la Noë and Ph. Ricaud. Observatoire de Bourdeaux, BP 89, 2 Rue de l'Observatoire, F-33270 Floriac, France.

Ph. Baron. Department of Meteorology, Stockholm University, SE-10691 Stockholm, Sweden and Observatoire de Bourdeaux, BP 89, 2 Rue de l'Observatoire, F-33270 Floriac, France.

J.R. Pardo. Astronomy Department, California Institute of Technology, 1200 E. California Blvd., Pasadena, CA 91125, U.S.A.

A. Hauchcorne. Service d'Aéronomie du CNRS, B.P. 3, F-9137 Verrières-le-Buisson Cedex, France.

E.J. Llewellyn,¹ D.A. Degenstein, R.L. Gattinger, and N.D. Lloyd. Institute of Space and Atmospheric Studies, University of Saskatchewan, Saskatoon, SK S7N 5E2, Canada.

W.F.J. Evans. Physics Department, Trent University, Peterborough, ON K9J 7B8, Canada.

I.C. McDade, C.S. Haley, C. Sioris, C. von Savigny, B.H. Solheim, and J.C. McConnell. EATS, York University, 4700 Keele Street, North York, ON M3J 1P3, Canada.

K. Strong. Physics Department, University of Toronto, 60 St. George Street, Toronto, ON M5S 1A7, Canada.

E.H. Richardson. EHR Associates, Victoria, BC V8N 1R1, Canada.

G.W. Leppelmeier. Department of Geophysics, Finnish Meteorological Institute, P.O. Box 503, FIN-00101 Helsinki, Finland and G & S Associates, Yläkaupinkuja 2, 02360 Espoo, Finland.

E. Kyrölä, H. Auvinen, and L. Oikarinen. Department of Geophysics, Finnish Meteorological Institute, P.O. Box 503, FIN-00101 Helsinki, Finland.

¹Corresponding author (e-mail: edward.llewellyn@usask.ca).

Abstract: Odin is a 250 kg class satellite built in co-operation between Sweden, Canada, France, and Finland and launched in February 2001. It carries two instruments: a 4-band sub-millimetre radiometer used for both astronomy and atmospheric science and an optical spectrometer and infrared imaging system for purely atmospheric observations. As part of the joint mission Odin will observe the atmospheric limb for 50% of the observation time producing profiles of many species of interest in the middle atmosphere with a vertical resolution of 1–2 km. These species include, among others, ozone, nitrogen dioxide, chlorine monoxide, nitric acid, water vapour, and nitrous oxide. An overview of the mission and the planned measurements is given.

PACS Nos.: 42.68Mj, 94.10Dy, 95.55Fw

Résumé : Odin est un satellite de la classe des 250 kg construit en collaboration par la Suède, le Canada, la France et la Finlande. Il a été lancé en février 2001. Il transporte deux instruments : un radiomètre sous-millimétrique à quatre bandes pour des mesures atmosphériques et astronomiques et un spectromètre optique avec système d'imagerie infrarouge pour des mesures de l'atmosphère. Dans ce projet conjoint, il est prévu qu'Odin observe le limbe atmosphérique pendant 50% du temps d'observation, afin de déterminer les concentrations de composés intéressants dans l'atmosphère moyenne, avec une précision de 1–2 km. Ces composés incluent, parmi d'autres, l'ozone, le bioxyde d'azote, le monoxyde de chlore, l'acide nitrique, la vapeur d'eau et l'oxyde nitreux.

[Traduit par la Rédaction]

Introduction

The genesis of the Odin project was the result of discussions between a number of radio astronomers and atmospheric scientists in 1990 of a possible synergism between the respective needs of radio astronomy and Earth observation from space. For astronomy, with the exception of a few windows, the sub-millimetre spectral region is only accessible from space and at the same time the spectral region offers increased sensitivity for the measurement of important trace gases in the stratosphere. Initial discussions focused on water vapour and carbon monoxide, both important molecules in the mesosphere and the interstellar medium, and gradually expanded to embrace other molecules such as chlorine monoxide in the stratosphere. During these discussions it also became clear that a second instrument, an optical spectrograph, would be required to measure some of the species that cannot be measured in the sub-millimetre region.

Thus, after a feasibility and phase-A study that resulted in a joint mission, Odin became the third in a series of Swedish small satellites following Viking (*Geophys. Res. Lett.* **14**(4) (1987), *J. Geophys. Res.* **95**(A5) (1990), and Freja (*Space Sci. Rev.* **70**(3–4) (1994)); both of these earlier satellites were dedicated to magnetospheric research. The Odin mission became a reality with the launch of the satellite on 20 February 2001, from Svobodny in eastern Siberia.

The goals of the atmospheric mission

The major question in atmospheric science at the time of the initial discussions for the Odin project, and still is today, is the extent to which humans are changing the atmospheric environment. The discovery of the ozone hole over Antarctica [1] illustrated in a very dramatic manner that human effects can be considerable and quite unexpected. The increase in the chlorine burden in the stratosphere caused by CFC (chloro-fluoro-carbons) releases produces a nonlinear response in the ozone concentration in the austral spring. This reduction in ozone concentration is due to the transformation of chlorine reservoir species to photochemically active forms through interaction with polar stratospheric clouds (PSCs). The restrictions on CFC releases that have now been adopted by the international community have already led to a reduction in the tropospheric chlorine values and the stratospheric values appear to be peaking. However, the downward temperature trend in the stratosphere due to the reduced ozone values, as well as increased amounts of CO₂ and other greenhouse gases, may lead to an increased PSC occurrence, and faster heterogeneous reaction rates at lower temperatures, may delay the recovery of ozone [2,3].

The initial goals for the Odin mission, expressed nearly 10 years ago [4] were as follows:

Stratospheric ozone science: To elucidate the geographical extent of and mechanisms responsible for ozone depletion in the “ozone hole” region and to study dilution effects and possible heterogeneous chemistry even outside of the polar regions due to sulphate aerosols.

Mesospheric ozone science: To establish the relative role of odd hydrogen chemistry and the effects of ordered and turbulent transport and corpuscular radiation.

Summer mesosphere science: To establish the variability of mesospheric water vapour including an assessment of the required fluxes for aerosol formation in the polar mesosphere.

Coupling of atmospheric regions: To study some of the mechanisms that provide coupling between the upper and lower atmosphere, e.g., downward transport of aurorally enhanced NO with its effects on ozone photochemistry and the vertical exchange of minor species such as odd oxygen, CO, and H₂O.

Although our scientific understanding, particularly of the stratosphere, has advanced since these goals were first defined there have been only minor modifications for the actual mission. Odin will provide three-dimensional distributions of ozone from about 14 km through to the upper mesosphere/lower thermosphere, near 100 km, with 1.5 km vertical resolution. Four different measurement techniques will be employed: sub-millimetre spectroscopy using several lines [5], limb DOAS [6], comparative limb radiance of the Rayleigh-scattered sunlight [7,8], and the 1.27 μm emission from the ozone photolysis product O₂(¹ Δ_g) [9]. These measurement techniques have very different physical bases and overlapping altitude regions. Thus Odin will provide a continuous internal validation of both the measurements and analysis techniques. Odin will also map the global distribution of ClO with much higher accuracy than has been previously possible (<20% uncertainty in single scans). Although Odin is unable to measure the reservoir species for chlorine these should be available from other missions, notably ESA's ENVISAT mission that is due for launch late in 2001, and so will provide opportunities for budget studies. The determination of ozone loss rates will also be simplified by the measurements of N₂O as it will be possible to unambiguously separate dynamical effects and chemical effects. This is particularly important in the northern polar region as the vortex break-up is controlled by dynamics. The role of odd nitrogen will also be determined through the measurement of NO₂ with the optical spectrograph, and HNO₃ and NO with the microwave radiometer. Data assimilation studies will be very significant for an improved understanding of all of these processes. As Odin is flying at the time of the solar/auroral maximum it will also be possible to study the effects of particle precipitation on the lower thermospheric concentration of NO.

The recent discovery of layers of excess water vapour [10] in the mesosphere has increased our interest in this part of the Odin mission. Odin will make important global measurements of the odd hydrogen components H₂O₂ and HO₂ at the same time as it measures water vapour and ozone. In the summer mesopause region the combination of accurate water vapour measurements and noctilucent cloud (NLC) particle observation, together with temperature, should provide new information on those factors that control NLC formation and thus the significance of the observed trends in the occurrence of these clouds [11–18].

The Odin satellite

The dual nature of the Odin mission (astronomy and aeronomy) has dictated the design of both the satellite platform and the payload.

The astronomy requirements include accurate three-axis pointing, the highest possible sensitivity for the sub-millimetre receivers, thermal stability of the platform to minimize drift in the receivers, both high (150 kHz) and medium (1 MHz) spectral resolution, and a low-loss antenna.

The aeronomy observations demand an antenna with low-side lobes, scanning of both the radiometer and optical spectrograph fields of view through the atmospheric limb, from 5–120 km tangent altitude, with good real time and reconstructed knowledge. In addition the spectrograph slit must be maintained parallel to the Earth limb. Finally, the mission lifetime must be at least 2 years.

These requirements have resulted in a compact small satellite with dimensions 2 × 3.8 × 3.8 m in flight configuration (see Fig. 1). The satellite includes a 1.1 m Gregorian telescope, with less than 10 μm

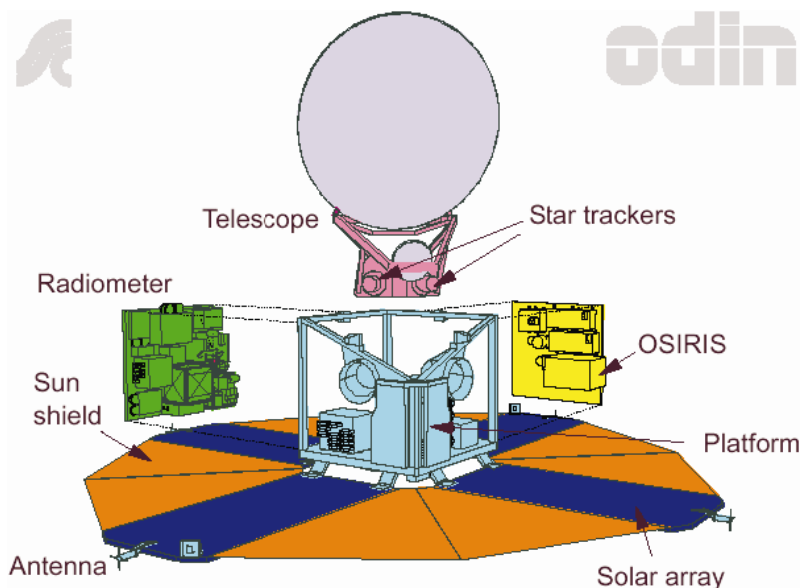
Fig. 1. Exploded view of the Odin Spacecraft.

rms surface roughness, an 80 K mechanical cooler and an advanced attitude control system (ACS) that moves the entire satellite to perform the limb-scans required for the aeronomy observations.

The ACS uses star trackers as the main sensors with backup from gyros, magnetometers, and Sun sensors. Reaction wheels and magnetic coils serve as actuators. The ACS has several modes that include an inertial pointing mode with 10'' pointing accuracy, a limb-scanning mode with 5' real time knowledge, and much better than 1' reconstructed knowledge, as well as a limb-tracking mode. The gyro drift between accurate star-tracker fixes limits the pointing knowledge.

Although the satellite is small all system units, with the exception of the mechanical cooler and the solar panels, have full redundancy. The various requirements of the combined mission have also impacted on the orbit selection. Maximum power from the solar array and maximum thermal protection is afforded by an 0600–1800 Sun-synchronous orbit and the final choice of an 18:00 LT ascending node was dictated by the aeronomy emphasis on the northern hemisphere.

The sub-millimetre radiometer (SMR)

The radiometer consists of 4 sub-millimetre channels and 1 mm wave channel. The choice of frequencies is described in an accompanying paper [19].

The incoming radiation is directed by a moving mirror to either of the two blocks of receivers A or B and C (see Fig. 2). The separation between the millimetre channel C and the sub-millimetre channels B1 and B2 is achieved with a dichroic filter. Within a sub-millimetre block separation is achieved using polarization while Martin–Pulpett interferometers are employed to provide single sideband filtering and injection into the Schottky mixers. The local oscillators are varactor-tuned Gunn diodes followed by doubler and tripler stages. The mixers and IF amplifiers are inside a cryostat and cooled to approximately 130 K by a 80 K Stirling cycle cooler. The measured detector noise temperatures are close to 3000 K for the sub-millimetre channels and 600 K for the millimetre channel. Detection is achieved using two hybrid autocorrelator spectrometers (AC1 and AC2) and an acousto-optical spectrometer (AOS) any of which can be connected to any of the front ends (receivers). In addition, AC1 is hard-wired through a single combiner to the A1 and A2 mixers so that a 400 MHz block in each band can be simultaneously measured using a single spectrometer. Similarly AC2 is hard-wired to mixers B1 and B2. The AC spectrometers have selectable resolutions from 150 kHz to 1.2 MHz and corresponding spectral coverage of 100 and 800 MHz. One AC includes a 3-unit filterbank that is permanently connected to the 119 GHz channel for temperature/pressure determination [20,21]. The AOS has a spectral coverage of 1 GHz and a resolution

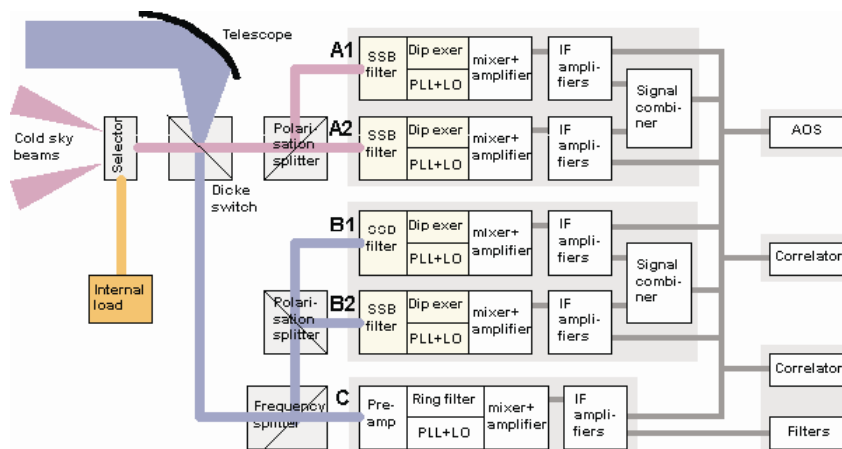
Fig. 2. Block diagram of the Odin radiometer.

of approximately 1 MHz. Several readout modes have been implemented to reduce the volume of data from the AOS by appropriate binning of spectral channels. Data from all of the spectrometers are stored in a 120 MB mass memory until the next downlink transmission opportunity.

Each of the sub-millimetre units is tunable over a 17 GHz range by using both sidebands and the tunability of the Gunn diodes. Space qualified mechanisms, with failsafe positions at the most important frequency settings, are used to tune the sideband filters and the LO injection. This flexibility allows coverage of most of the spectral regions that are of interest for both astronomy and aeronomy.

While one block of mixers is observing the atmosphere through the telescope the other is directed toward a calibration mechanism where it can view either the internal ambient temperature load or cold space through one of two openings in the spacecraft. In this way any drift in the detectors can be properly compensated.

The optical spectrograph and infrared imager (OSIRIS)

The optical component of the Odin satellite, which is only used for the aeronomy mission, is a combined optical spectrograph and infrared imaging system (OSIRIS). The entrance slit for the optical spectrograph is aligned parallel to the horizon, to minimize height smearing, while the three one-dimensional array detectors in the infrared imager are aligned perpendicular to the horizon. For the Odin aeronomy observations the SMR and OSIRIS, which are co-aligned, point at the limb and the nodding of the entire spacecraft provides the range of tangent altitudes that is required for the determination of the height distributions. The OSIRIS data are of two types:

1. Scattered sunlight spectra containing atmospheric absorption features within the wavelength range 280–800 nm — these data will be provided by the optical spectrograph.
2. Atmospheric emission features (airglow) in the wavelength range 280–800 nm and near 1270 nm and 1530 nm — these data will be provided by both the optical spectrograph and the infrared imager.

In the case of the scattered solar spectra the Sun acts as a light source against which absorption by lines and diffuse bands of species such as ozone and NO₂ can be measured, and hence column abundances inferred. An example of the on-orbit scattered limb spectra, calculated using the MODTRAN code, is shown in Fig. 3. The general decrease in the scattered intensity below 330 nm is due to both Rayleigh extinction and ozone absorption, the broad absorption feature near 550 nm is also due to ozone while the narrow feature at 762 nm is due to molecular oxygen. It is the application of wavelength correlation techniques to these spectra that allows the column concentrations of the absorbing species to be recovered with great sensitivity. This technique, commonly called DOAS (differential optical absorption spectroscopy), has been successfully used with ground-based observations of the polar atmosphere [22]

Fig. 3. Typical on-orbit limb spectra that will be measured with OSIRIS. These spectra were calculated using the MODTRAN code for high-latitude winter conditions and convolved with a 10 Å slit function.

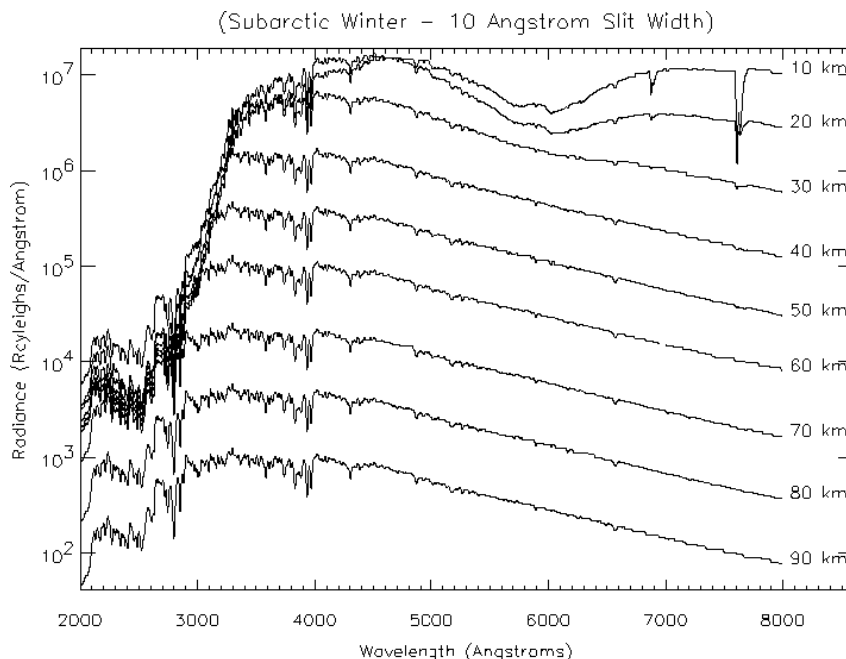

and is presently being exploited by the GOME satellite [23]. However, the highly structured nature of the illuminating spectrum means that particular care must be taken with the absorption cross sections used in the DOAS retrievals. As already noted there is a complementary nature to the optical and SMR observations and, while each instrument can operate on its own, it is the collaborative use of the data that will enhance the retrievals from both instruments.

The optical spectrograph, which operates over the wavelength range 280–800 nm, is a modified Ebert–Fastie with an aspheric grating and an order-sorter prism that eliminates spectral overlap. It is the novel design of the order-sorter prism that moves the light out of the plane of the grating that provides a major reduction in the spectral cross talk. It is readily apparent from the model data shown in Fig. 3 that for low-tangent altitude observations wavelengths near 300 nm are particularly susceptible to contamination from the bright visible region signals. This spectral cross talk is further complicated by the wavelength dependence of the quantum efficiency of the CCD detector, a 1353 × 286 array. The actual detector is operated in a frame transfer MPP mode with only 32 rows of the imaging section of the array illuminated by the slit image. Radiation detected outside the slit image provides information on the internal scattering properties of the spectrograph and so allows this aspect of the imager performance to be monitored throughout the Odin mission. The detector is cooled passively through a large radiator plate, although it was initially planned to use thermoelectric cooling. As OSIRIS is pointed at the limb, the entrance slit to the spectrograph subtends a region 30 km long by 1 km high, the bright Earth is always close to the optical axis so good rejection of off-axis scattered light is essential. For the spectrograph the effect of this scattered light has been reduced through the use of a beam-fold mirror that is located between the telescope mirror and the entrance slit. However, the choice of the orbit ascending node is also an important factor. As Odin is in a Sun-synchronous 18:00 LT ascending-node orbit it operates close to the terminator so that there is a significant reduction in the albedo component of the scattered light.

The infrared imager part of OSIRIS is three separate co-aligned single-lens imagers operating at 1263, 1273, and 1530 nm. The spectral regions are selected using interference filters and the imaging is achieved with one-dimensional InGaAs (128 pixel) linear arrays that are thermoelectrically cooled. The detector dark current is monitored through the use of 18 masked pixels at one end of each array. The

spectral regions have been selected to provide a redundancy in the observation of the oxygen infrared atmospheric band at 1270 nm. This airglow feature is excited in the daytime through the photolysis of ozone. As there is a different amount of self-absorption for each of the two selected wavelength regions the comparison of the observed intensities also provides new information on atmospheric absorption. It should be noted that the oxygen airglow brightness is so large that the Rayleigh-scattered signal at this wavelength is not significant above a tangent altitude of 30 km [24]. The 1530 nm imager observes both Rayleigh-scattered sunlight and the OH Meinel vibrational-rotational band airglow (there are contributions from both the 3-1 and 4-2 bands). During the day the airglow signal is close to the limit of detection but after sunset the airglow is readily detectable. These measurements can be combined with the derived ozone concentrations to derive the atomic hydrogen profile in the atmosphere in the region of the Meinel band emission. These data can also be extended with the spectrograph airglow observations to allow new studies of the mesospheric airglow. However, the primary new capability afforded by the imager is the ability to make tomographic observations that can be used to provide horizontal structure information (better than 300 km resolution) from the limb observations. This represents a major advance over current limb-observing techniques.

The infrared imager observations are inverted using a technique that follows the tomographic procedure that was developed by members of the Odin team [25–27]. This technique provides a high spatial resolution two-dimensional picture of the observed emissions. However, the actual retrieval of the minor species concentrations from the two-dimensional emission-rate distributions is complicated by absorption and requires the application of an adaptive-inversion algorithm [27].

Preliminary work during the OSIRIS phase-A study demonstrated that the development model of the OSIRIS instrument should be capable of providing the DOAS measurements required for the Odin aeronomy objectives. However, the various contributions to the radiance observed in the limb near twilight are quite complicated and it has been necessary to develop, and test, new retrieval algorithms [28–32]. The unabsorbed broad-band-scattered light also contains information about both atmospheric temperature and aerosols. The scale height of the unabsorbed scattered sunlight provides the atmospheric temperature profile [33,34] and any significant departures from the altitude distribution expected for a Rayleigh-scattering atmosphere can be interpreted in terms of aerosols, and a back-scattering ratio [35].

The orbit and spacecraft orientation

As noted the Odin orbit is circular Sun synchronous, at 620 km, with the ascending node at 18:00 LT. This ensures maximum power to the satellite and also provides a stable thermal environment since eclipses only occur for a restricted period during the year (around the northern hemisphere summer solstice). Odin will be flown so that the solar panels are always orientated within 35° of the Sun. This ensures that the power production is at least 80% of its maximum value and that the payload and telescope are always shaded from direct sunlight. This provides additional spacecraft thermal stability that is particularly important for the astronomy mission as the sources are weak and very long integration times will be needed.

The observation modes

While the Odin radiometer is very flexible the limited number of receivers and spectrometers precludes simultaneous observations of all species of interest. Four main observing modes have, therefore, been defined: the stratospheric mode, the odd nitrogen mode, the odd hydrogen mode, and the water isotope mode. The names have been chosen to reflect the primary, but not the only, scientific topic for each mode. For instance the odd hydrogen mode will also be used to study the water vapour concentration in the upper part of the mesosphere during dedicated noctilucent cloud studies.

In the stratospheric mode (see ref. 19 for a list of the frequency settings), the target species for the SMR will be: ozone, nitric acid, chlorine monoxide, and nitrous oxide while OSIRIS will measure ozone, nitrogen dioxide, bromine monoxide, OClO, and aerosols. The terrestrial limb is scanned at a rate of 0.75 km s⁻¹ continuously from 7–60 km with calibrations performed at both the top and bottom of each scan. It is anticipated that single scan profiles can be produced for all species.

In the odd nitrogen mode nitric oxide will be measured in the middle and upper stratosphere, so giving the mode its name. With measurements of the source gas N_2O and the reservoir HNO_3 , combined with the OSIRIS NO_2 measurements, it will be possible to evaluate the partitioning of odd nitrogen derived in models. This mode also provides measurements of ozone and HO_2 .

In the odd hydrogen mode HO_2 and H_2O_2 are the main targets, together with their source gas H_2O . Water vapour is measured in two frequency ranges that allow complete coverage from below 15 to 90 km. Unfortunately the odd hydrogen species are difficult to measure and considerable averaging will be required to obtain a good signal.

In the latter two modes limb scanning will be performed from 7–100 km with calibrations again being performed at both the top and bottom of each scan. In the water isotope mode HDO and H_2^{18}O will be the targets of interest and will be measured simultaneously with N_2O , HNO_3 , and ozone.

The observation program

As has been noted Odin is a two-discipline satellite and the atmospheric measurements have to be interleaved with the astronomy observations. The basic principle is that each discipline should have 50% of the available observing time. To allow for the possibility of extended periods of observations the basic aeronomy observation will be one complete set of 15 orbits (1 day) repeated each 3 days and executed with the receivers set to the stratospheric mode. In addition there will be an extra day of observations after each third basic day. This extra day will be used for observations in one of the other modes. To facilitate studies of rapidly changing situations, as well as more detailed studies, two blocks of seven days are reserved during the northern and southern hemisphere spring periods. These periods will be introduced into the program when the geophysical situation is of particular interest. They are nominally shown in Fig. 4, the distribution of observing time between aeronomy and astronomy, as being at the beginning of February and October respectively. A further special period has been added in July for studies of the northern hemisphere summer mesopause region. All days during this period that are not part of the basic program will be dedicated to the observations of the mesopause region in the northern hemisphere. This study will use the odd hydrogen mode to provide the most sensitive measurements of water vapour and will have a restricted altitude scan from 70–110 km to provide better horizontal coverage.

Unfortunately the characteristics of the Odin orbit, and the requirement that the solar panels be kept within 35° of the Sun, are such that the region of the sky that is of greatest interest to the astronomers, the galactic plane and centre, is only observable in March and September. To alleviate the over subscription of astronomy time some extra days are assigned to astronomy during September. During this period stratospheric measurements are only made every sixth day. The choice of the austral springtime rather than the arctic spring was made because the ascending node of the Odin orbit has been selected so as to allow optical measurements as early as possible in the northern hemisphere. This means that it is not possible to measure in the Antarctic stratosphere in September.

Data processing and analysis

All spacecraft command and data reception is performed by the ground station at Esrange, near Kiruna, in northern Sweden. Approximately 10 of the 14–15 orbits per day are suitable for data retrieval. Data are transmitted in a FIFO method to the ground station where they are separated according to their origin: housekeeping, AOS, AC1, etc. They are then transferred, using ftp, to the main Odin data storage centre, the parallel data centre (PDC) in Stockholm. The different instrument groups are notified via email when new data have been placed in the centre. Level 0–1 processing for the radiometer is carried out at Chalmers University of Technology while the OSIRIS data are processed at the University of Saskatchewan. Level 1 files, in HDF format, are returned to the PDC so that Level 1–2 processing can be made. For the radiometer the main processing will occur at the Department of Meteorology, Stockholm University (MISU) with validation processing at the Observatoire de Bordeaux. The forward modeling and inversion procedures are described in other papers [19,36,37] in this issue. For OSIRIS the main processing will occur at both the University of Saskatchewan and at the FMI facility at Sodankylä, Finland.

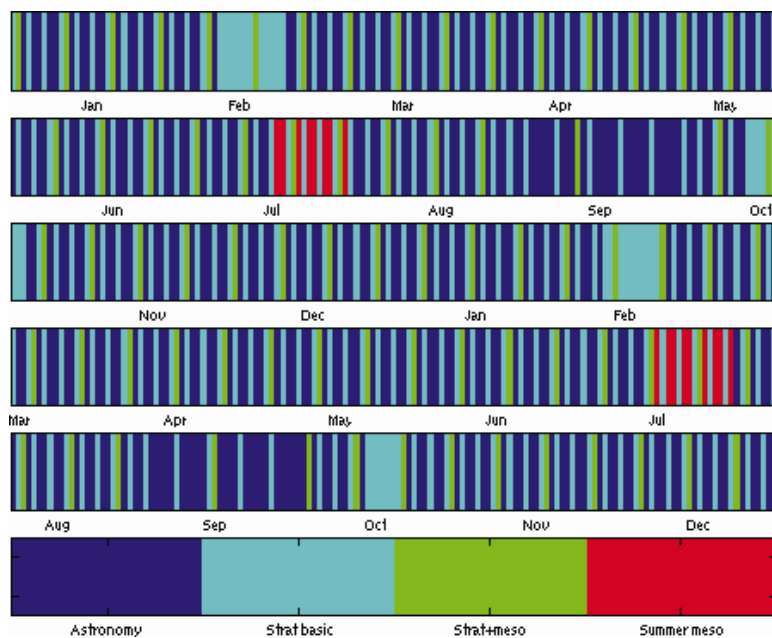
Fig. 4. The distribution of observing time between the aeronomy and astronomy programs.

Conclusions

The Odin small satellite carries a complement of new instruments that will provide unique data on the composition of the middle atmosphere. In particular Odin will be the only satellite with a capability to measure active chlorine for the next few years.

Acknowledgements

We thank Nik Kämpfer and colleagues (Bern University) for initial calculations of sub-millimetre spectra and Rolf Mewe and Jan Wijnbergen (SRON) for help with instrument requirements and sensitivity calculations during the phase-A study. The authors would also like to thank all of the dedicated and unnamed individuals who have made the Odin mission a reality. The Odin project is funded by the Swedish National Space Board (SNSB), the Canadian Space Agency (CSA), and the Natural Sciences and Engineering Research Council of Canada (NSERC), the Finnish technical agency Tekes, and the Centre National d'Études Spaciales (CNES) in France.

References

1. J.C. Farman, B.G. Gardiner, and J.D. Shanklin. *Nature*, **315**, 207 (1985).
2. D.T. Shindell, D. Rind, and P. Lonergan. *Nature*, **392**, 589 (1998).
3. D.T. Shindell, G.A. Schmidt, R.L. Miller, and D. Rind. *J. Geophys. Res.* **106**, 7193 (2001).
4. D.P. Murtagh, G. Witt, R. Mewe, H. van der Woerd, N. Kämpfer, P. Taalas, J. Askne, and A. Winnberg. Report AP-31, Department of Meteorology, Stockholm University, Stockholm. 1993.
5. J. Waters. *Microwave limb sounding, atmospheric remote sensing by microwave radiometry*. Edited by M.A. Janssen. John Wiley and Sons, Inc., New York. 1993.
6. I.C. McDade, K. Strong, C.S. Haley, J. Stegman, D.P. Murtagh, and E.J. Llewellyn. *Can. J. Phys.* **80** (2002). This issue.
7. D.E. Flittner, P.K. Bhartia, and B.M. Herman. *Geophys. Res. Lett.* **27**, 2601 (2000).
8. R.D. McPeters, S.J. Janz, E. Hilsenrath, T.L. Brown, D.E. Flittner, and D.F. Heath. *Geophys. Res. Lett.* **27**, 2597 (2000).

9. W.F.J. Evans and E.J. Llewellyn. *Radio Sci.* **7**, 45 (1972).
10. D.E. Siskind and M.E. Summers. *Geophys. Res. Lett.* **25**, 2133 (1998).
11. M. Gadsden. *J. Atmos. Terr. Phys.* **52**, 247 (1990).
12. M. Gadsden. *J. Atmos. Solar-Terr. Phys.* **60**, 1163 (1998).
13. F.-J. Lübken. *Geophys. Res. Lett.* **27**, 3603 (2000).
14. F.-J. Lübken, K.-H. Fricke, and M. Langer. *J. Geophys. Res.* **101**, 9489 (1996).
15. G.E. Thomas, J.J. Olivero, E.J. Jensen, W. Schroeder, and O.B. Toon. *Nature*, **338**, 490 (1989).
16. G.E. Thomas and J.J. Olivero. *J. Geophys. Res.* **94**, 14 673 (1989).
17. G.E. Thomas. *Geophys. Monograph*, **87**, 185 (1995).
18. G. von Cossart, J. Fiedler, and U. von Zahn. *Geophys. Res. Lett.* **26**, 1513 (1999).
19. F. Merino, D.P. Murtagh, M. Ridal, P. Eriksson, P. Baron, P. Ricaud, and J. de La Noë. *Can. J. Phys.* **80** (2002). This issue.
20. J.R. Pardo, M. Ridal, D. Murtagh, and J. Cernicharo. *Can. J. Phys.* **80** (2002). This issue.
21. M. Ridal, D.P. Murtagh, F. Merino, J.R. Pardo, and L. Pagani. *Can. J. Phys.* **80** (2002). This issue.
22. S. Solomon, A.L. Schmeltekopf, and R.W. Sanders. *J. Geophys. Res.* **92**, 8311 (1987).
23. K.V. Chance, J.P. Burrows, D. Perner, and W. Schneider. *J. Quant. Spectrosc. Radiat. Transfer*, **57**, 467 (1997).
24. E.J. Llewellyn, D.A. Degenstein, I.C. McDade, R.L. Gattinger, R. King, R. Buckingham, E.H. Richardson, D.P. Murtagh, W.F.J. Evans, B.H. Solheim, K. Strong, and J.C. McConnell. *Appl. Photon. Technol.* **2**, 627 (1997).
25. I.C. McDade and E.J. Llewellyn. *Can. J. Phys.* **69**, 1059 (1991).
26. I.C. McDade and E.J. Llewellyn. *Can. J. Phys.* **71**, 552 (1993).
27. D.A. Degenstein. Ph.D. thesis, University of Saskatchewan, Saskatoon, Sask. 1999.
28. E. Griffioen and L. Oikarinen. *J. Geophys. Res.* **105**, 29 717 (2000).
29. C.A. McLinden, J.C. McConnell, E. Griffioen, and C.T. McElroy. *Can. J. Phys.* **80** (2002). This issue.
30. C.A. McLinden, J.C. McConnell, K. Strong, I.C. McDade, R.L. Gattinger, R. King, B.H. Solheim, W.F.J. Evans, D.A. Degenstein, and E.J. Llewellyn. *Can. J. Phys.* **80** (2002). This issue.
31. L. Oikarinen, E. Sihvola, and E. Kyrölä. *J. Geophys. Res.* **104**, 31 261 (1999).
32. K. Strong, B.M. Joseph, R. Dosanjh, I.C. McDade, C.A. McLinden, J.C. McConnell, J. Stegman, D.P. Murtagh, and E.J. Llewellyn. *Can. J. Phys.* **80** (2002). This issue.
33. D.P. Murtagh, J. Stegman, G. Witt, E.J. Llewellyn, and I.C. McDade. *Planet. Space Sci.* **35**, 1149 (1987).
34. M.G. Shepherd, A. Dudhia, M. Lopez-Puertas, and W.F.J. Evans. *Geophys. Res. Lett.* **24**, 357 (1997).
35. W.F.J. Evans, L.R. Laframboise, K.R. Sine, R.H. Wiens, and G.G. Shepherd. *Geophys. Res. Lett.* **22**, 2793 (1995).
36. P. Baron, P. Ricaud, J. de la Noë, P. Eriksson, F. Merino, and D.P. Murtagh. *Can. J. Phys.* **80** (2002). This issue.
37. P. Eriksson, F. Merino, D.P. Murtagh, P. Baron, P. Ricaud, and J. de la Noë. *Can. J. Phys.* **80** (2002). This issue.