

# Analyses of the Long-Term Performance and Tribological Behavior of an Axial Piston Pump Using Diamondlike-Carbon-Coated Piston Shoes and Biodegradable Oil

M. Kalin

e-mail: mitjan.kalin@ctd.uni-lj.si

F. Majdič

J. Vižintin

J. Pezdirnik

I. Velkavrh

Centre for Tribology and Technical Diagnostics,  
University of Ljubljana,  
Bogisiceva 8,  
1000 Ljubljana, Slovenia

*This work reports on the performance enhancement of a real-scale hydraulic system consisting of diamondlike-carbon (DLC)-coated components in combination with biodegradable oil in long-term experiments under conditions simulating those in an actual application. The performance of a hydraulic axial piston pump with DLC-coated piston shoes was evaluated in a newly designed, dedicated hydraulic test system using fully formulated biodegradable, synthetic ester oil. For comparison, an equal but separated hydraulic system with a conventional commercial pump and stainless-steel shoe surfaces was tested. The tests were run at 85% of the maximum pump load and an oil temperature of around 80°C for a period of 2000 h, which corresponds to more than 1 yr of continuous 8 h/day operation in an application. A major abrupt oxidation-induced degradation of the oil did not occur in either system; however, the oil from the system comprising the DLC-coated shoes showed noticeably and consistently better results. The wear of the DLC-coated shoes, especially during the running in, was much lower than that in the conventional steel system. Only minor polishing wear was observed on the DLC shoe's sliding surfaces during the test period, while on the steel shoe's surfaces, many scratches were found and some erosion of the edges was detected. [DOI: 10.1115/1.2805442]*

*Keywords:* DLC, biodegradable oil, piston pump, hydraulics, tribology

## 1 Introduction

Environmental awareness plays an increasingly important role in the selection and development of technical systems. This is especially so for machines and systems used in forests, agriculture, mining, construction, etc. Lubricants and lubrication are some of the major concerns when it comes to the environment. It was estimated that about 10% of all the lubricants used in Europe are exposed to natural surroundings [1], which increases the already high level of pollution. In many countries and regions, legislation and lately also customers require technical systems with the appropriate solution for environmental care. For example, biodegradable oils can offer one solution to the above problem.

The common biodegradable oils are natural oils, such as rapeseed oil or sunflower oil, and synthetic esters. Natural biodegradable oils possess good antiwear properties and low friction. However, their oxidation and thermal stability is poor, and this is their major drawback [2]. The properties that affect the oxidation stability most significantly are the number of reactive groups and the level of saturation of the fatty acids in these oils. More double (or triple) bonds suggest faster and easier oxidation of the oil, and natural biodegradable oils contain many of these groups (see Fig. 1). On the other hand, synthetic esters are more resistant to oxidation and thermal degradation, but their tribological properties are not as good as those of natural esters. Namely, some of the conventional (metal) boundary-lubrication mechanisms are based

on the adsorption of oil/additive polar groups at the oxidized metal surface, where oils with nonsaturated molecules and with more polar groups (such as  $-\text{COOH}$ ) also possess more sites for reactions and/or adsorption with metal surfaces that can provide boundary-lubrication effects [3,4]. Thus, the more saturated nature and the lower polarity of typical synthetic esters suggest a poorer lubrication ability.

Accordingly, a large number of polar groups improves the tribological performance of conventional metal tribosystems, but this also causes oil oxidation, especially at high temperatures. Any reduction in the oil temperature can thus help reduce the oxidation and prolong the lifetime of these oils. Moreover, a reduced oil temperature could enhance and/or enable the use of these oils in some systems.

Diamondlike carbon (DLC) coatings are known to reduce wear and provide low friction even under dry conditions [5–10]. The lower friction directly reduces the amount of heat generated and the system's temperature. Many model tribological studies have already focused on the lubrication of DLC coatings using different types of base oils—including biodegradable oils, additives, contact conditions, etc. [11–16]. Typically, the low-friction behavior of DLC coatings was maintained, suggesting their beneficial effect on friction also under lubricated conditions. What is more, it was shown that more polar and less saturated base oils improve the tribological performance when used in combination with DLC coatings [17].

It seems, therefore, that the combination of DLC coatings and biodegradable oils would have a great deal of potential for at least the three positive effects discussed above: (i) to protect the mechanical parts against wear due to the use of wear-protective DLC

Contributed by the Tribology Division of ASME for publication in the JOURNAL OF TRIBOLOGY. Manuscript received March 6, 2007; final manuscript received August 14, 2007; published online December 26, 2007. Review conducted by Hong Liang.

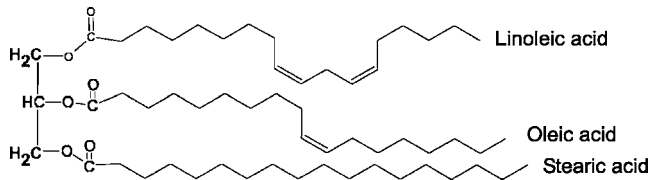

**Fig. 1 Typical triglyceride composition (vegetable oil) with three different types of fatty acid having different levels of saturation (number of double bonds)**

in the lubricated contacts, (ii) to improve the lubrication behavior due to better adsorption of the nonsaturated molecules in base oil, and (iii) to prolong the lifetime of the biolubricant due to the reduced friction and the lower oil temperature. However, DLC coatings are “inert” and have a low surface energy [18,19], thus they are less prone to react with the oils and additives than steel. In spite of the several above-mentioned positive and optimistic results (these are mainly empirical), the mechanisms of boundary lubrication and chemical interactions are still very poorly understood—if at all—and frequently they are put in question. This is especially true and justified when the performance of real-scale mechanical systems is investigated. Here, more parameters—system dynamics, running in, and, in particular, long-term operation and oil degradation—are included in the overall performance than in the model tests.

In our previous studies, we have already investigated the short-term performance of DLC-coated real-scale mechanical systems in combination with biodegradable oil, e.g., spur gears under scuffing loads [20] and grinding machine centers [21], and positive results, especially in terms of a reduced temperature, were obtained. In the present work, however, we present the performance of an “environmentally adapted” axial piston pump (using biodegradable oil and DLC-coated contacting surfaces) in a long-term test of 2000 working hours, which corresponds to 1 yr of continuous every-working-day operation and is close to the expected lifetime of a biodegradable oil in such a system, in order to verify our previously obtained, promising results. The tests were performed in a newly developed, dedicated hydraulic test rig. A commercially available DLC coating was used for the piston shoes, and the system was lubricated with an in-house-developed fully formulated biodegradable oil. For comparison, the same experiment was simultaneously run in a conventional pump using the same oil but without any coated surfaces.

## 2 Experiment

**2.1 Testing System and Materials.** An axial piston hydraulic pump, which is a typical component in many hydraulic systems exposed to the natural environment, was selected for the testing system in this study (Fig. 2). There are a few parts in this pump that suffer from excessive wear in practice, and the contact between the piston shoes and the swash plate is one of the most critical. Figure 3 shows a photograph of the assembly of nine piston shoes and the assembling plate inserted in the cylinder block. Only the top surfaces of the piston shoes (shown in Fig. 3) were DLC coated, as during the operation they slide over a swash plate. During the deposition of the coating, the other surfaces of the shoes were carefully protected in order to prevent any change in the tolerances, motion capabilities, and surface quality compared to the conventional shoe surfaces.

The DLC coating used was a commercially available, pure, nondoped amorphous hydrogenated (*a*-C:H) coating, containing about 30 at. % of hydrogen. The coating adhesion was enhanced with a thin (<0.5  $\mu\text{m}$ ) Si-based interlayer. The deposition process used was radio-frequency plasma-assisted chemical vapor deposition (CVD) at 13.56 MHz. The total thickness of the layer was  $1.8 \pm 0.09 \mu\text{m}$ , and the average  $R_a$  roughness was  $0.06 \pm 0.01 \mu\text{m}$ .

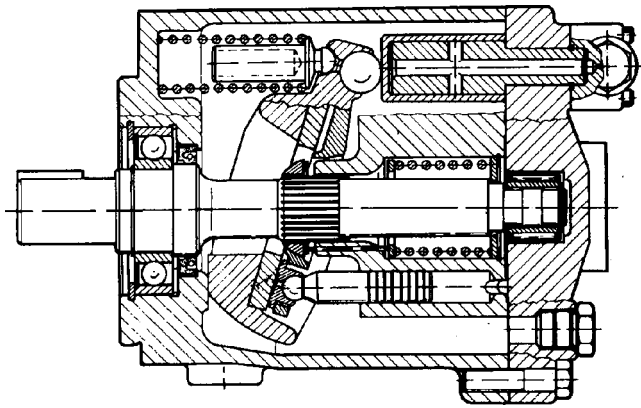

**Fig. 2 Schematic of the design and the working principle of the axial piston pump**

The shoes that were coated and those noncoated that were used in the second, i.e., the reference, pump were made from steel, conventionally used and obtained from the pump producer (Vickers, Eaton Corp., Hydraulic Supply Company, FL). However, to ensure good adhesion of the coating and the prevention of spalling, the shoes had to be additionally polished to a proper roughness, as mentioned above. This surface smoothing was made on all the shoes, i.e., on both pump sets, to maintain the same surface roughnesses.

The oil used was a fully formulated in-house-developed biodegradable saturated complex ester having a viscosity grade of ISO VG 46 and a viscosity index of 138. The oil was formulated for a typical hydraulic application, including antiwear additives, friction modifiers, and antioxidants, and satisfied the load-carrying properties according to a FZG test (DIN 51354-2). During the development of the oil, the most efficient conventional additives were used. However, since the oil is labeled as “biodegradable,” the final oil composition had to comply with the specific biodegradability criteria. With this respect, we have used, among several other tests such as elastomer compatibility (ISO 6072), oxidation stability (DIN 51554-3 and ASTM D 943), etc., two types of biodegradability tests, i.e., CEC L33-A-95 and OECD 301F,



**Fig. 3 Assembly of the pistons with DLC-coated shoes, inserted into the pump cylinder block**

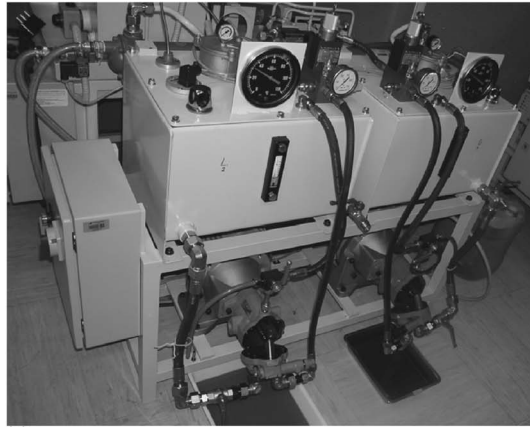

(a)

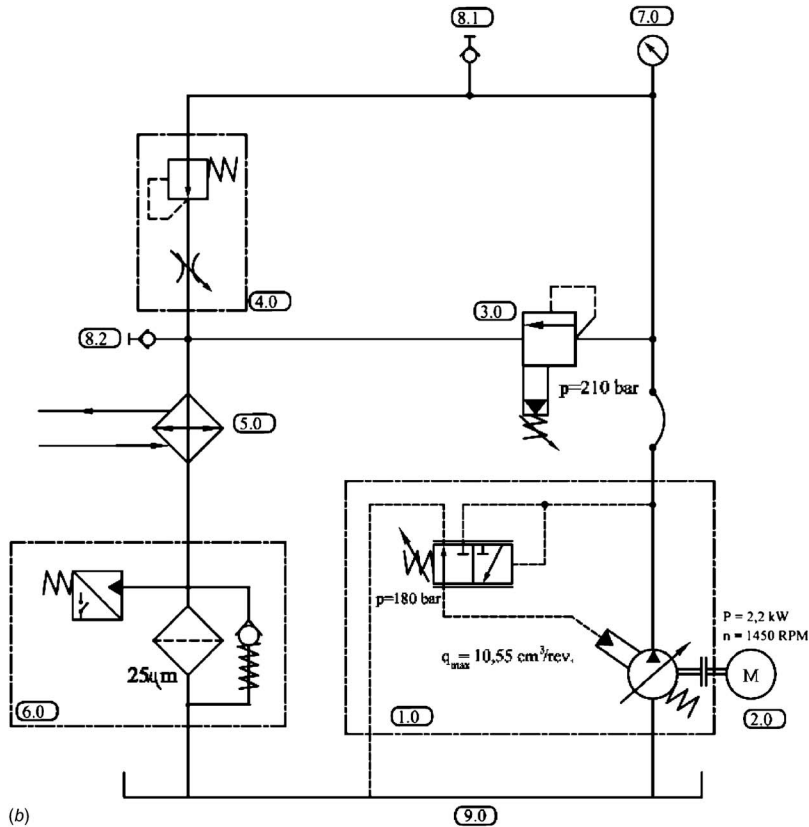

(b)

**Fig. 4** (a) A photograph of the hydraulic piston-pump test rig with two identical testing systems and (b) schematic of a single hydraulic circuit (positions: 1.0, variable axial piston pump); 2.0, electric motor; 3.0, relief valve; 4.0, pressure-compensated flow-control valve; 5.0, water cooler; 6.0, return-line filter with pressure indicator and bypass valve; the  $\beta$  value for a particle size over  $25 \mu\text{m}$  is more than 150 (absolute filtration at that size); 7.0, pressure gauge; 8.1 and 8.2, microhose coupling; 9.0, reservoir 30 l

while for the toxicity OECD 202 (*Daphnia Magna*) was used. Final formulation of the oil fulfilled all the required criteria.

**2.2 Test Rig.** A new test rig (Fig. 4(a)) that consists of two equal but separate hydraulic circuits was designed. Each circuit consists of the following major parts: conventional or modified (DLC-coated shoes) variable axial piston pump (Vickers PVB5 R/L SY 40 C 12) as a testing unit, a 2.2 kW drive motor, an oil reservoir of 30 l, our own (separate) lubricant, an oil-flow-regulation pressure-compensating valve, a hydraulic pressure valve, a bypass system for online oil-leakage measurements and oil sampling, a water-cooling system, a filter (the  $\beta$  value for the

particle size over  $25 \mu\text{m}$  is more than 150; absolute filtration), and a regulator. A schematic of a single hydraulic circuit is presented in Fig. 4(b). The oil temperature, a key parameter for oil oxidation stability, was controlled by the regulation system with a cooling chamber. In one separate testing system, the head of the piston shoes in the pump were DLC coated, as described above, while in the other, no coating deposition was made on the commercial pump, i.e., conventional contacts were used.

**2.3 Testing Procedure.** First, the reservoirs and pipes were cleaned with the same type of oil as used in the tests, which was

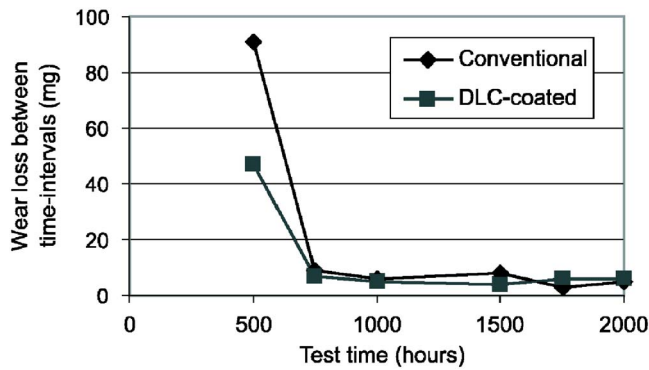

**Fig. 5** Wear loss of the set of conventional and DLC-coated shoes

then removed after the cleaning. Prior to the actual experiments, 30 l of fresh oil were put into each system, each piston was marked for its position in the cylinder block and then weighed.

The pump load (pressure) was set to 85% of its maximum value (210 bars), i.e., to 180 bars, and the corresponding outlet flow of the pump was set to 6 l/min. The electromotor speed was 1450 rpm. The oil temperature was controlled and maintained by a regulation system and a cooling unit at 70–75 °C in the reservoir, which corresponds to 80–85 °C in the pump.

The testing conditions were first stabilized to equal values in both systems and then the tests were started and simultaneously run for a total of 2000 h. After a selected number of working hours, the test system was stopped and the pump was disassembled. The contacting surfaces were analyzed in terms of roughness, examined with optical microscopy, and then photographed. Each piston was weighed separately to determine the wear loss. The total wear of all the pistons in each pump set was used for the evaluation and is plotted in graphs. This same procedure was performed after 500 h, 750 h, 1000 h, 1500 h, 1750 h, and 2000 h. After the examination, the pump was reassembled and the test was continued. During reassembling, all the parts were carefully put in the same place and in the same relative position to each other to ensure as uniform and equal test conditions as possible in all stages of the test. During these stops, the total acid number (TAN) and the kinematic viscosity of the oils from both reservoirs were analyzed using a Mettler DL25 titrimetric analyzer (Mettler-Toledo GmbH, Giessen, Germany) and a Cannon-Fenske capillary viscometer (Schott-Gerate GmbH, Mainz, Germany), respectively. The oil samples were taken from the central part of the reservoir just prior the stop. These two parameters were selected to monitor the oxidation rate of the oil.

Another hydraulic parameter that indicates the wear condition of the contacting surfaces, i.e., the pump leakage, was also monitored. Pump leakage was measured online, during operation, in the purposely designed leakage line after 3 h, 300 h, 400 h, 500 h, 750 h, 1250 h, 1750 h, and 2000 h by measuring the amount of oil that was collected within 30 s at the bypass system just prior to stopping the system for disassembly and wear analyses, where these two analyses coincide. However, a few more checking times were selected due to the online system and the ability to control the condition of the pump.

### 3 Results

Figure 5 shows the total wear of a whole set of nine conventional and DLC-coated piston shoes within the pump. It is clear that the wear was the highest during the initial 500 h. It is also clear that the wear in the conventional steel system was much higher than that in the DLC-coated system, i.e., by as much as two times. The wear between all the analyzed periods after the 500 h evaluation was about ten times lower than the wear measured in



(a)



(b)

**Fig. 6** A photograph of the piston-shoe front surfaces after 500 h on (a) DLC-coated piston shoe and (b) steel piston shoe

the initial period of 500 h. It appears that running-in phenomena are responsible for most of the wear. From the results, it is clear that the running in was particularly beneficial and less severe for the DLC-coated system than for the conventional system. After the initial period, the rate of wear was much lower and steady, and no distinctive increase was measured through the end of the test, after 2000 h. This was true for both the tested systems.

The appearance of the contacting surfaces of the piston shoes is mainly in agreement with the wear data; however, there are some clear, qualitative differences between the conventional and the DLC-coated shoes. After 500 h, almost no changes can be observed with the DLC shoes (Fig. 6(a)). Grinding scratches from the preparation of the samples/piston shoes are still visible and the coating covered the whole surface, i.e., no spalling or major signs of wear were observed. However, there is a distinctive circular region observable on the shoe's surface, most probably representing an area of more intense contact against the swash plate. In contrast, many scratches in various directions could be seen on the steel shoes, indicating abrasive damage (Fig. 6(b)). Several larger scratches are also observed, which agrees with the higher and more severe wear during the running in and also a higher measured wear loss (Fig. 5). Namely, the loose wear debris that were generated during the running-in period were trapped in the pump and at least occasionally in the contact, which causes these abrasive marks. Moreover, if these debris were to deform in the contact and become work hardened, they could become even more abrasive and cause a lot of damage during operation.

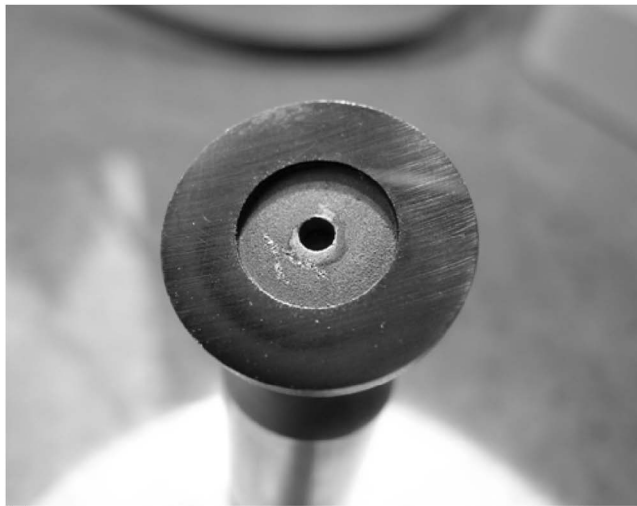

(a)



(b)

**Fig. 7** A photograph of the piston-shoe front surfaces after 750 h on (a) DLC-coated piston shoe and (b) steel piston shoe

Figure 7 shows the piston-shoe surfaces after 750 h of testing. Again, practically no changes can be seen on the DLC-coated shoes; they still show the oriented grinding scratches from the shoe-manufacturing process (Fig. 7(a)). On the other hand, the conventional steel shoes have many scratches on the surface but in various directions (Fig. 7(b)), the same as after 500 h. In addition, damage to the inner edge of the sliding surface is also clearly evident. This is typical erosion damage to the shoe for this type of pump; it is caused by the abrasive particles in the oil. Since there was a lot of wear measured in this system during the initial stage (see Fig. 5), most probably the wear particles that were generated during the running in initiated this erosion wear. This type of wear is dangerous because of the increased leakage and the reduced power efficiency if the number of eroded edges increases excessively with time. Therefore, it is essential to reduce the amount of wear and the amount of wear debris in the pump that can cause this type of damage. Accordingly, the low wear observed with the DLC-coated shoe surfaces is also very beneficial because of the reduced risk of erosion wear, not only because of the abrasive wear of the shoe front surfaces.

With the increasing number of testing hours, the appearance of the surfaces did not change significantly until the end of the test after 2000 h. However, most of the DLC-coated shoes were only



(a)



(b)

**Fig. 8** A photograph of the piston-shoe front surfaces after 2000 h on (a) DLC-coated piston shoe and (b) steel piston shoe

slightly worn and smoothed, which suggests a mild wear regime during the test for these surfaces. No wear through or spallation of the coatings was observed. A few DLC-coated shoes, however, showed small pits in the surface (Fig. 8(a)). These features are typical, even for the unworn surfaces, and it did not affect the performance of the pump. After 2000 h, the coating and the whole system still performed very well.

In contrast, the noncoated conventional steel shoes have numerous scratches on the front surface in various directions (Fig. 8(b)), indicating that these are the result of wear, not from the sample preparation, as is the case with the DLC shoes. It seems that on several steel shoe surfaces, the number of scratches increased and that some of them were very pronounced. However, overall, the severity of the wear and the form of the abrasive damage did not increase significantly, nor did the failure mode change. According to the wear data (Fig. 5), the operation of this pump also seems to be acceptable, but with a lower surface quality and potential stress intensities and leakage in the later stages of operation.

The leakage was measured at several time intervals during the operation of both systems, typically just prior to stopping the system. From Fig. 9 it can be concluded that the leakage did not change significantly during the testing period, compared to the initial, inherent leakage of the pumps. The variation of the data is reasonable and within the expected scatter. Namely, since the leakage is proportional to the gap in the contact to the third power, it is clear that gaps in the tested systems did not change signifi-

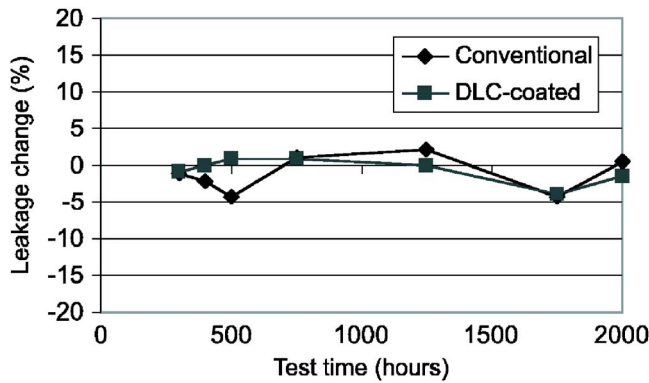

Fig. 9 Leakage of the oil in the pump with the conventional steel and DLC-coated shoes, compared to the initial/inherent pump leakage

cantly during the period of testing (even a very small change in the gap would result in an increase in leakage by a few percent). Moreover, a consistent trend that would indicate wear-related leakage was not observed. It can also be seen that the variation between the conventional and DLC-coated systems is negligible and within the measurement uncertainty. This is in agreement with the wear data and the overall observation of the surfaces.

The viscosity of the oil, which indicates oxidation when it increases, was relatively stable during the experiment. The change of about 1–2 mm<sup>2</sup>/s that was found during the experiments can be considered small (Fig. 10). The difference was even smaller for the oil from the system with the DLC-coated shoes. A slightly more significant change was observed in the initial 500 h for the conventional steel system. In this initial stage, the decrease in the viscosity of biodegradable oils is expected and typical and does not necessarily indicate the oxidation of the oil. Namely, since the quantity of fatty acids is the most sensitive to these changes and in very plentiful in ester oils, it is expected that some of these molecules would rearrange and degrade initially and thus the viscosity would drop slightly, as was in fact observed. Moreover, based on the measurements, it appears that severe oxidation of the oil did not start during the whole of the 2000 h test. An increase of more than 5% would be expected under such conditions. In reality, however, the viscosity of the oil in our experiments was observed to decrease. The reason for this slight decrease during the later stages is not clear, but it is very possible that it is due to the measurement uncertainty over the period of 2000 h. Nevertheless, it is interesting to note that the oil from the system with DLC-coated surfaces consistently exhibited a smaller change in viscosity than the oil from the conventional system.

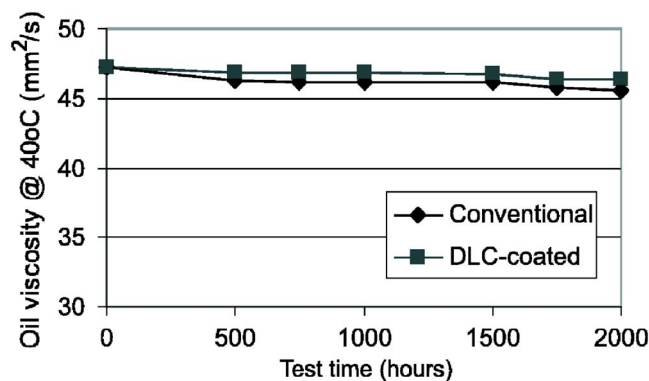

Fig. 10 Kinematic viscosity of the oil in the systems with conventional and DLC-coated piston-shoe surfaces during the 2000 h test

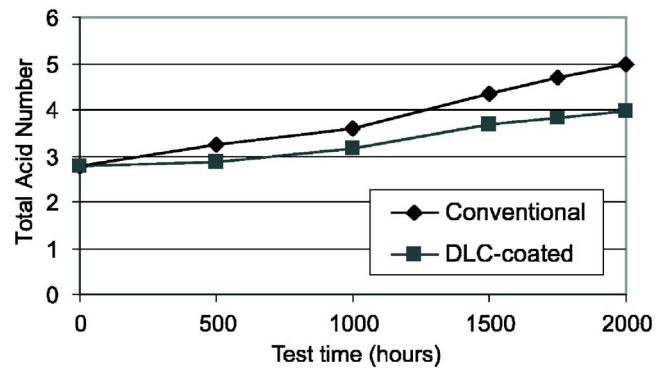

Fig. 11 TAN measurements of the oil for conventional steel and DLC-coated piston-shoe surfaces during the 2000 h test

The results of the TAN measurements are presented in Fig. 11. The TAN values for both systems increase steadily. The changes are relatively small and indicate partial oxidation of the oils. However, there was no significant or sudden change that would indicate an abrupt and critical degradation of the oil due to severe oxidation. This also agrees with the other results, presented above. However, it should be noticed that the change in the TAN values was about two times higher for the conventional steel system than that for the DLC-coated system, which indicates a much more stable performance and a noticeably slower oxidation-degradation process. This agrees with the viscosity measurements, where the differences were smaller for the DLC-coated system. The TAN results, therefore, suggest the satisfactory behavior of biodegradable oil even in a long-term (2000 h) experiment under relatively high loads and at high temperatures (above 80°C), and this is particularly so for DLC-coated systems, when compared to the conventional stainless-steel piston pump.

#### 4 Discussion

Several studies in the past have dealt with the behavior of DLC coatings under lubricated conditions and even with DLC coatings lubricated with biodegradable oils. However, most of these studies were performed using tribological model testers or—when testing with real-scale mechanical components—in short-term experiments. Such screening tests are reasonable and necessary to obtain the phenomenological behavior of selected systems, but they do not show other, more complex responses, which are associated with the dynamics and long-term behavior, for example, oil degradation. When high temperatures are associated with real-scale applications or oxidation-sensitive oils are used, such as biodegradable oils, this is even more important and pronounced and the results could differ significantly when compared to simpler model tests. Following this “conventional strategy,” we have previously reported on the beneficial effect of a combination of high-polar and nonsaturated base oils together and DLC coatings [17,22] using model tribological tests. Moreover, in short-term mechanical-component tests, we have also determined that the use of DLC coatings can lead to a reduced system temperature and thus protect and/or delay the oxidation of the biodegradable oil [20,21]. In the present work we tried to verify these positive results in a real-scale system but this time using a time period comparable to that of a real-life operation.

This study thus reports on a long-term investigation of a hydraulic system’s performance. The system has an axial piston pump as its major component. The tests were conducted over 2000 h, a time that corresponds to operating for 8 h/day for more than 1 yr. One of the pumps contained piston shoes that were DLC coated, while the other had conventional, commercial steel shoes. From the results, it is obvious that the coated surfaces did not wear out or experience any catastrophic wear mode, such as

spalling or detachment. On the contrary, only minor polishing-type wear with smoothening of the surfaces occurred under selected conditions over the whole period of the test (Figs. 6(a), 7(a), and 8(a)). Most of the wear occurred during running in, while during the later stages, the wear was much lower. On the other hand, the conventional system experienced about two times more wear loss than the coated system during the initial 500 h (Fig. 5). Obviously, the running-in period was significantly improved by the use of DLC-coated shoes. Moreover, the wear debris that were generated in the conventional steel system during running in most probably got trapped in the pump and occasionally at the contact. If this occurs, the debris also become work hardened and therefore even more abrasive. This subsequently caused abrasive wear scratches on the front shoe surfaces (Figs. 6(b), 7(b), and 8(b)), as well as erosive wear of the inner ring edges (see particularly Fig. 7(b)). The abrasive scratches were visible for all the test intervals, and they accumulated during the test, as can be seen by their increase in number during the period of the test. In contrast, no scratches or any other signs of wear, except smoothening, were found on the DLC-coated shoe surfaces, clearly indicating significantly improved wear behavior and performance of the coated system. With prolonging the testing time (over 2000 h), these defects would probably become even more pronounced due to the stress intensities and the amount of damage, leading eventually to leakage from the system. The severe erosion marks on the shoe edges that were observed after just 750 h (Fig. 7(b)) certainly support such a possible scenario.

The lower amount of wear in the DLC-coated system (Fig. 5) also suggests lower "pollution" of the oil due to released wear debris. Moreover, since the wear particles in the oil also increase the rate of oil oxidation, this could suggest improved oxidation performance of the oil, too. In accordance with this suggestion, we have indeed observed that, consistently, the oil oxidation related data, i.e., TAN and viscosity, were always better for oils using the DLC-coated shoes than those for the conventional ones (see Figs. 10 and 11).

Nevertheless, the TAN and kinematic viscosity results indicate that the rate of oxidation of the oil did not change a great deal. Rather, they changed slowly and steadily, indicating that there was no catastrophic degradation of the oil during the test period of 2000 h. The changes were relatively small and indicate only a partial oxidation of the oils. After the initial rearrangement and degradation of the unsaturated molecules and a typical slight decrease in the oil's viscosity, the viscosity measurements did not suggest any major difference in the behavior of the two systems (Fig. 10). However, the oil from the system with the DLC-coated surfaces provides slightly but consistently smaller changes in the viscosity than the oil from the conventional system. The TAN results are much more distinctive and decisive. The change in the TAN values was about two times higher for the conventional steel system than that for the DLC-coated system (Fig. 11), which implies a much more stable performance and a noticeably slower oxidation-degradation process. The TAN results therefore suggest the satisfactory behavior of the biodegradable oil even in a long-term (2000 h) experiment at relatively high loads and temperatures (above 80°C) and improved oxidation performance when used in combination with DLC-coated surfaces. One of the reasons for the lower oxidation degradation is the lower overall friction, and thus the lower overall oil temperature, as we found in our previous scuffing-gear experiments [20]. Another important reason is the reduced oil degradation during the solid asperity-contact incidents in the case of the DLC-coated surfaces, which are more frequent in the case of conventional steel contacts due to more wear debris being generated during the running in. These incidents are also more severe due to the higher adhesion susceptibility of the steel surfaces compared to that of the DLC, which also results in higher asperity-contact temperatures.

To summarize, the performance of the hydraulic system with the axial piston pump having DLC-coated piston shoes and using

biodegradable synthetic hydraulic oil was more stable during the 2000 h of testing operating at 85% of maximum load (180 bars) and at 80–85°C and caused noticeably lower oxidative changes of the oil, as well as significantly lower damage to the shoe surfaces compared to conventional steel shoe surfaces.

## 5 Conclusions

The present work confirms several positive effects of a combination of a biodegradable lubricant and DLC-coated surfaces even for the long-term operation of a real-scale hydraulic system. The results are broadly similar to some previous studies that used model tribological tests and short-term mechanical-components tests. The key results can be summarized as follows:

- The modified hydraulic pump with the DLC-coated shoes performed noticeably better than the conventional commercial pump with steel shoes in terms of reduced abrasive and erosive wear on the piston-shoe surfaces, lower wear-debris generation, improved running in with mild polishing wear, smoother surfaces after run in, and a lower amount of debris in the system.
- The modified hydraulic pump with the DLC-coated shoes also resulted in more stable values and a smaller change in the oil's viscosity and an approximately two times lower change in the TAN of the oil. These data suggest significantly reduced oxidation of the oil compared to the conventional system, which most probably occurred due to reduced overall temperature of the oil and the asperity contacts and the amount of oxidative wear debris, which leads to prolonged life of the oil compared to a conventional steel system.
- During a period of 2000 working hours at 85% of maximum load, i.e., 180 bars, and around 80–85°C, no severe degradation of the oil or damage to the DLC-coated surfaces was observed.

## References

- [1] Bartz, W. J., 1998, "Lubricants and the Environment," *Tribol. Int.*, **31**(1–3), pp. 35–47.
- [2] Igartua, A., Aranzabe, J., Barriga, J., and Rodriguez, B., 1998, "Tribological Study for the Application of Biodegradable Lubricants in the Industry," *COST 516 Tribology Symposium Proceedings*, H. Ronkainen and K. Holmberg, eds., VTT, Espoo, pp. 135–146.
- [3] Mortier, R. M., and Orszulik, S. T., 1993, *Chemistry and Technology of Lubricants*, Blackie Academic, Glasgow.
- [4] Stachowiak, G. W., and Batchelor, A. W., 1993, *Engineering Tribology*, Elsevier Science, Amsterdam.
- [5] Erdemir, A., 2004, "Diamond-Like Carbon Films," *Tribology of Mechanical Systems: A Guide to Present and Future Technologies*, J. Viřintin, M. Kalin, K. Dohda, and S. Jahanmir, eds., ASME, New York, pp. 139–156.
- [6] Voevodin, A. A., Donley, M. S., and Zabinski, J. S., 1997, "Pulsed Laser Deposition of Diamond-Like Carbon Wear Protective Coatings: A Review," *Surf. Coat. Technol.*, **92**, pp. 42–49.
- [7] Grill, A., 1999, "Diamond-Like Carbon: State of the Art," *Diamond Relat. Mater.*, **8**, pp. 428–434.
- [8] Donnet, C., and Grill, A., 1997, "Friction Control of Diamond-Like Carbon Coatings," *Surf. Coat. Technol.*, **94–95**, pp. 456–462.
- [9] Erdemir, A., 2004, "Genesis of Superlow Friction and Wear in Diamondlike Carbon Films," *Tribol. Int.*, **37**, pp. 1005–1012.
- [10] Liu, Y., Erdemir, A., and Meletis, E. I., 1997, "Influence of Environmental Parameters on the Frictional Behaviour of DLC Coatings," *Surf. Coat. Technol.*, **94–95**, pp. 463–468.
- [11] Ye, J., Ueoka, K., Kano, M., and Yasuda, Y., 2004, "Ultralow Friction of DLC Lubricated With Ester Containing Oil—Part 2: Nanoscratch Analysis of Surface Friction," *Transient Processes in Tribology*, A. A. Lubrecht and G. Dalmaz, eds., Elsevier, Amsterdam, pp. 693–698.
- [12] Podgornik, B., Viřintin, J., Jacobson, S., and Hogmark, S., 2004, "Tribological Behaviour of WC/C Coatings Operating Under Different Lubrication Regimes," *Surf. Coat. Technol.*, **177–178**, pp. 558–565.
- [13] Miyake, S., Saito, T., Yasuda, Y., Okamoto, Y., and Kano, M., 2004, "Improvement of Boundary Lubrication Properties of Diamond-Like Carbon (DLC) Films due to Metal Addition," *Tribol. Int.*, **37**, pp. 751–761.
- [14] Ban, M., Ryoji, M., Fujii, S., and Fujioka, J., 2002, "Tribological Characteristics of Si-Containing Diamond-Like Carbon Films Under Oil-Lubrication," *Wear*, **253**, pp. 331–338.
- [15] Kalin, M., Viřintin, J., Barriga, J., Vercammen, K., Van Acker, K., and Arņšek, A., 2004, "The Effect of Doping Elements and Oil Additives on the Tribologi-

- cal Performance of Boundary-Lubricated DLC Contacts,” *Tribol. Lett.*, **17**(4), pp. 679–688.
- [16] Kalin, M., and Vižintin, J., 2006, “Differences in the Tribological Mechanisms When Using Non-Doped, Metal-Doped (Ti, WC), and Non-Metal-Doped (Si) Diamond Like Carbon Against Steel Under Boundary Lubrication, With and Without Oil Additives,” *Thin Solid Films*, **515**, pp. 2734–2747.
- [17] Kalin, M., Vižintin, J., Vercammen, K., Barriga, J., and Arnšek, A., 2006, “The Lubrication of DLC Coatings With Mineral and Biodegradable Oils Having Different Polar and Saturation Characteristics,” *Surf. Coat. Technol.*, **200**, pp. 4515–4522.
- [18] Sanchez-Lopez, J. C., Erdemir, A., Donnet, C., and Rojas, T. C., 2003, “Friction-Induced Structural Transformations of Diamondlike Carbon Coatings Under Various Atmospheres,” *Surf. Coat. Technol.*, **163–164**, pp. 444–450.
- [19] Grischke, M., Hieke, A., Morgenweck, F., and Dimigen, H., 1998, “Variation of the Wettability of DLC-Coatings by Network Modification Using Silicon and Oxygen,” *Diamond Relat. Mater.*, **7**, pp. 454–458.
- [20] Kalin, M., and Vižintin, J., 2005, “Tribological Performance of DLC Coated Gears With Biodegradable Oil: The Effect of Gear/Pinion Material Combinations,” *Wear*, **259**, pp. 1270–1280.
- [21] Barriga, J., Kalin, M., Van Acker, K., Vercammen, K., Ortega, A., and Leiaristi, L., 2006, “Tribological Performance of Titanium Doped and Pure DLC Coatings Combined With a Synthetic Bio-Lubricant,” *Wear*, **261**, pp. 9–14.
- [22] Kalin, M., and Vižintin, J., 2006, “A Comparison of the Tribological Behaviour of Steel/Steel, Steel/DLC and DLC/DLC Contacts When Lubricated With Mineral and Biodegradable Oils,” *Wear*, **261**, pp. 22–31.