

ANALYSIS AND DESIGN OF NEW ACTIVE QUASI CIRCULATOR AND CIRCULATORS

R. Bahri, A. Abdipour, and G. Moradi

Microwave/mm-wave & Wireless Communication Research Lab.
Electrical Engineering Department
Amirkabir University of Technology
Tehran, Iran

Abstract—This paper introduces two new type active quasi circulators and three new type active circulators which use the out-of-phase power divider/combiner, symmetric/anti-symmetric couplers and generic unilateral amplifiers. The proposed circuits are full-symmetric and composed of conventional microwave devices. Analytical relations for active quasi circulator modules are described. These modules have many variations and can be used for very wide frequency range depending on the type of the employed unilateral amplifier, power divider/combiner and symmetric/anti-symmetric couplers. Based on the proposed configurations, analysis and design of n -port active circulators are presented. Also they can be used in MMICs as active quasi circulators, active circulators and in other high frequency applications.

1. INTRODUCTION

Circulators with three or more ports are nonreciprocal functional blocks used in microwave and millimeter systems that separate incident and reflected waves. To reach the next port the incident signal at one port circulates in only one direction, namely, clockwise or counterclockwise, and non-adjacent ports are isolated from each other. Conventional circulators are usually fabricated with passive, non-reciprocal ferrite materials. But using ferrite materials make them expensive; also they are not compatible with monolithic integration [1]. The most important specifications of active circulator and quasi circulator are their inherent advantages such as size, weight and cost over conventional ferrite devices [2–8]. Active circulator and quasi circulator are also highly compatible with monolithic technology and

Corresponding author: R. Bahri (Reza-bahri@aut.ac.ir).

are being used as part of complete microwave transmit receive front-ends.

Employing the non-reciprocal characteristic of transistors for active circulator has been described in 1965 by Tanaka [2]. But its upper frequency cutoff was very low, about 3 MHz. Another reported active circulator used three conventional FETs, in which their sources were connected together [3]. In this design, the frequency response was extended to 2.1 GHz, and the insertion loss and isolation are reported as 6, and 18 dB, respectively. In [4], employing line-unified FETs (LUFETs) has been proposed, which can operate over a wide frequency range (1–10 GHz). This circuit consists of an active out-of-phase divider and an active in-phase combiner. Combination of power divider and combiner leads to an active quasi circulator module. In [5], an active circulator is shown, which uses three amplifiers in a network, and there is a power coupler at the junction among amplifiers. Also, a narrowband integrated active circulator antenna is proposed in [6] for transmit-receive applications. This circulator was a hybrid circuit implemented using a set of amplifiers in a network. In [7], a microstrip active quasi circulator module is presented using two generic amplifier blocks and two power couplers. The power couplers are parallel-coupled lines with a slow-wave structure in order to improve the isolation between ports of the quasi circulator module.

In this paper, we propose new configurations which are actually active quasi circulator modules and active circulators. An analytical design method is presented for active quasi circulator module. The developed circuit can replace a conventional circulator even though it is not a complete circulator. By using these quasi circulator modules, designing a multi-port active circulator is possible. The formulation of n -port active circulator is presented in this paper. The proposed circuits can be used as a microwave element in commercial simulators. In the previously mentioned works, there is no signal amplification between adjacent ports, and designs were not modular. But in this new method the amplification of circulated signal between ports is considered and can be adjusted for special applications. The proposed structures are the results of modular design that can be extended to multi-port active circulators.

This paper is organized as follows. Section 2 demonstrates the basic block diagrams of proposed active quasi circulator modules; Section 3 introduces the configuration of active 3-port circulators; Section 4 gives the configurations of n -port active circulator; Section 5 presents an example by employing unilateral broadband distributed amplifier for active circulator and quasi circulator. Finally, conclusions are summarized in Section 6.

2. BASIC CONFIGURATIONS AND DESIGN OF QCMS

A three-port device that transfers power from port 1 to port 2 and from port 2 to port 3, but does not transfer power from port 3 to port 1 is a quasi circulator module. According to this description, the desired S-matrix of a quasi circulator module and its block diagram are shown in Fig. 1.

Two proposed active quasi circulator modules are shown in Fig. 2. Each configuration consists of two unilateral generic amplifiers and

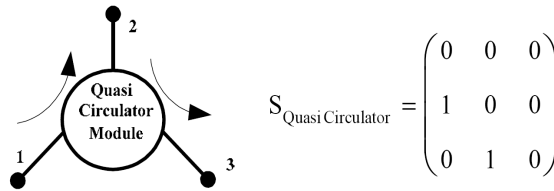
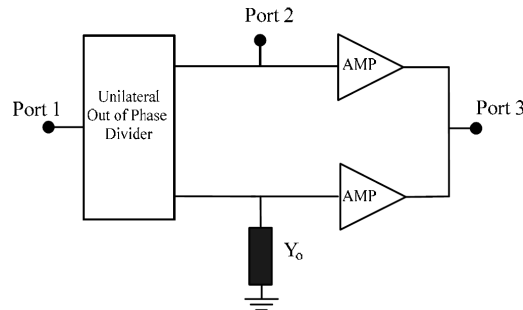
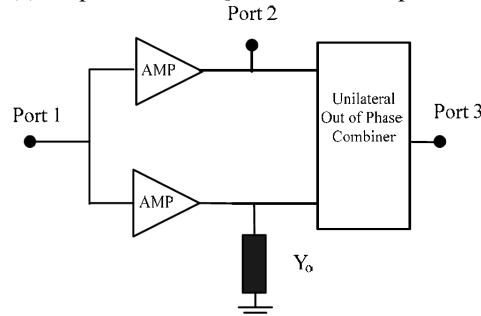

Figure 1. Quasi circulator module.



(a) Proposed active QCM with out-of-phase divider



(b) Proposed active QCM with out-of-phase combiner

Figure 2. Two proposed configurations of active QCMs.

one out-of-phase power divider/combiner, which are connected to each other, making an active quasi circulator module. It should be considered that the outputs of power divider and inputs of power combiner are isolated from each other. The used unilateral amplifiers in each structure are similar. The important features of these proposed circuits are using unilateral out-of-phase power divider/combiner and one type of general unilateral amplifiers.

2.1. Active QCM with Out-of-phase Divider

As shown in Fig. 2(a), the signal enters the circuit at port 1, whereupon it encounters an out of phase power divider, so is divided to out-of-phase signals. These out-of-phase signals at port 3 have equal magnitudes, because the impedance of port 2 and Y_0 are equal, and the used unilateral amplifiers are similar. Therefore, the incident signal at port 1 cancels out at port 3. The incident signals at port 2 will be amplified and appear at ports 3, and half power of incident signal at port 1 appears at port 2. On the other hand, because of the unilateral characteristics of the power divider and amplifiers, we have $S_{12} = S_{23} = S_{13} = 0$.

Now, we try to obtain analytical relations for this proposed active quasi circulator. Suppose that the \mathbf{Y} matrix of unilateral amplifiers and out-of-phase power divider are:

$$Y_{\text{Amp}} = \begin{pmatrix} Y_{11} & 0 \\ Y_{21} & Y_{22} \end{pmatrix} \tag{1}$$

$$Y_{\text{Divider}} = \begin{pmatrix} a & 0 & 0 \\ g & b & t \\ -g & t & b \end{pmatrix} \tag{2}$$

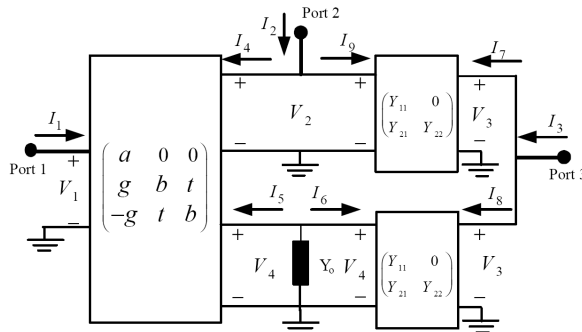

Figure 3. Schematic of the proposed active quasi circulator.

In this matrix (2), a , b , g and t are the input admittance, output admittance, forward transadmittance and transadmittance between output ports, respectively. The details of connections between power divider and two amplifiers, considering the first block diagram in Fig. 2(a), are shown in Fig. 3. The obtained relations between voltages and currents are:

$$\begin{cases} I_1 = aV_1 \\ I_4 = gV_1 + bV_2 + tV_4 \\ I_5 = -gV_1 + tV_2 + bV_4 \\ I_9 = Y_{11}V_2 \\ I_7 = Y_{21}V_2 + Y_{22}V_3 \\ I_6 = Y_{11}V_4 \\ I_8 = Y_{21}V_4 + Y_{22}V_3 \end{cases} \quad (3)$$

By considering the conditions in Fig. 3, we have the following set of equations:

$$\begin{cases} I_5 + I_6 + Y_0V_4 = 0 \\ I_2 = I_4 + I_9 \\ I_3 = I_7 + I_8 \end{cases} \quad (4)$$

Now, by substituting (3) to (4):

$$\begin{cases} I_1 = aV_1 \\ I_2 = gV_1 + (b + Y_{11})V_2 + tV_4 \\ I_3 = Y_{21}V_2 + 2Y_{22}V_3 + Y_{21}V_4 \\ V_4 = \frac{g}{b+Y_{11}+Y_0}V_1 - \frac{t}{b+Y_{11}+Y_0}V_2 \end{cases} \quad (5)$$

Therefore, the admittance matrix of proposed active quasi circulator module (Fig. 2(a)) is:

$$Y_{\text{QCM}} = \begin{pmatrix} a & 0 & 0 \\ g\left(1 + \frac{t}{b+Y_{11}+Y_0}\right) & b + Y_{11} - \frac{t^2}{b+Y_{11}+Y_0} & 0 \\ \frac{Y_{21}g}{b+Y_{11}+Y_0} & Y_{21}\left(1 - \frac{t}{b+Y_{11}+Y_0}\right) & 2Y_{22} \end{pmatrix} \quad (6)$$

By using $\mathbf{S} = (Y+Y_0)^{-1}(Y_0-Y)$, the scattering matrix will be obtained from admittance matrix. The result is:

$$\mathbf{S} = \begin{pmatrix} \frac{Y_0-a}{Y_0+a} & 0 & 0 \\ \frac{-2Y_0g}{(Y_0+a)(Y_0+Y_{11}+b-t)} & \frac{Y_0^2-(Y_{11}+b)^2+t^2}{(Y_0+Y_{11}+b)^2-t^2} & 0 \\ 0 & \frac{-2Y_0Y_{21}}{(Y_0+2Y_{22})(Y_0+Y_{11}+b+t)} & \frac{Y_0-2Y_{22}}{Y_0+2Y_{22}} \end{pmatrix} \quad (7)$$

This matrix introduces a quasi circulator module, when $S_{11} = S_{22} = S_{33} = 0$. These conditions give the following set of equations:

$$\begin{cases} a = Y_0 \\ t^2 = (Y_{11} + b)^2 - Y_0^2 \\ Y_{22} = Y_0/2 \end{cases} \quad (8)$$

So the proposed configuration in Fig. 2(a), will be a quasi circulator module. The scattering matrix of the proposed active quasi circulator is expressed as follows:

$$\mathbf{S} = \begin{pmatrix} 0 & 0 & 0 \\ G_1 & 0 & 0 \\ 0 & G_2 & 0 \end{pmatrix}$$

$$G_1 = \frac{-g}{(Y_0 + Y_{11} + b \mp \sqrt{(Y_{11} + b)^2 - Y_0^2})} \quad (9)$$

$$G_2 = \frac{-Y_{21}}{(Y_0 + Y_{11} + b \pm \sqrt{(Y_{11} + b)^2 - Y_0^2})}$$

In this relation, G_1 is power gain from port 1 to port 2, and G_2 is power gain from port 2 to port 3. As shown in (10), there is a relation among power divider, amplifier parameters and obtained gains. Because of using unilateral out-of-phase power divider, the incident signal at port 1 will be divided into two signals with obtained gain (G_2). Therefore, the incident signal at port 1 cancels out at port 3. Also the incident signal at port 2 will appear at port 3. Due to the unilateral characteristic of power divider and amplifiers, the incident signals at ports 2 and 3 do not appear at ports 1 and 2, respectively. These values (G_1 & G_2) are adjustable for special applications.

2.2. Active QCM with Out-of-phase Combiner

In the second structure that is shown in Fig. 2(b), the signal enters the circuit at port 1, in which it encounters a set of parallel lines to the out-of-phase power combiner and one direct line to port 2. So amplified signal appears at port 2, and two signals appear at the inputs of power combiner. These two signals to port 3 are out-of-phase and equal in magnitude because the admittance of port 2 equals Y_0 . Therefore, the incident signal cancels out at port 3. On the other hand, S_{12} , S_{23} and S_{13} are zero because of the unilateral characteristics of the power combiner and amplifiers. The incident signals to ports 2 will appear at port 3. The \mathbf{Y} matrix of the unilateral amplifiers and power divider are supposed to be:

$$Y_{\text{Amp}} = \begin{pmatrix} Y_{11} & 0 \\ Y_{21} & Y_{22} \end{pmatrix} \quad (10)$$

$$Y_{\text{Combiner}} = \begin{pmatrix} a & t & 0 \\ t & a & 0 \\ g & -g & b \end{pmatrix} \quad (11)$$

In this matrix, a , b , g are the input admittance, output admittance, forward transadmittance respectively, and t is transadmittance

between input ports. Similar to the used method for Fig. 3, by substituting these matrixes in Fig. 2(b), the scattering matrix will be obtained.

$$\mathbf{S} = \begin{pmatrix} \frac{Y_0 - 2Y_{11}}{Y_0 + 2Y_{11}} & 0 & 0 \\ \frac{-2Y_0 Y_{21}}{(Y_0 + b)(Y_0 + Y_{22} + a - t)} & \frac{Y_0^2 - (Y_{22} + a)^2 + t^2}{(Y_0 + Y_{22} + a)^2 - t^2} & 0 \\ 0 & \frac{-2Y_0 g}{(Y_0 + 2Y_{11})(Y_0 + Y_{22} + a + t)} & \frac{Y_0 - b}{Y_0 + b} \end{pmatrix} \quad (12)$$

By choosing $S_{11} = S_{22} = S_{33} = 0$, the matrix introduces a quasi circulator module. The result of these conditions is the following set of equations:

$$\begin{aligned} b &= Y_0 \\ t^2 &= (Y_{22} + a)^2 - Y_0^2 \\ Y_{11} &= Y_0/2 \end{aligned} \quad (13)$$

By applying Equation (13), the final \mathbf{S} -matrix of the second proposed quasi circulator module is expressed as follows:

$$\begin{aligned} \mathbf{S} &= \begin{pmatrix} 0 & 0 & 0 \\ G_1 & 0 & 0 \\ 0 & G_2 & 0 \end{pmatrix} \\ G_1 &= \frac{-Y_{21}}{Y_0 + Y_{22} + a \mp \sqrt{(Y_{22} + a)^2 - Y_0^2}} \\ G_2 &= \frac{-g}{Y_0 + Y_{22} + a \pm \sqrt{(Y_{22} + a)^2 - Y_0^2}} \end{aligned} \quad (14)$$

Similar to the first proposed configuration, due to using unilateral amplifiers and power combiner in this configuration, there are power gains between ports. As mentioned later these values are adjustable for special applications.

3. BASIC CONFIGURATIONS AND DESIGN OF ACTIVE CIRCULATOR

By using power divider/combiner (Fig. 4) and symmetric/anti-symmetric couplers (Fig. 5), design of a 3-port active circulator is described. Also the block diagrams to design an n -port active circulator based on described 3-port active circulator are proposed. Power divider/combiner and symmetric/anti-symmetric couplers are passive microwave components used for power dividing or power combining. In a two way power divider, an input signal is divided by the coupler into two signals of lesser power. The coupler may

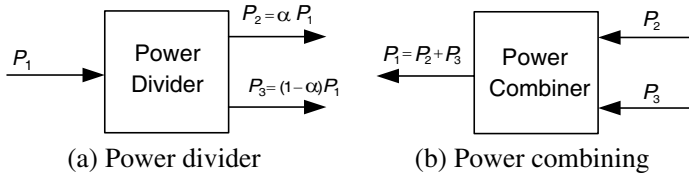

Figure 4. Power dividing and combining.

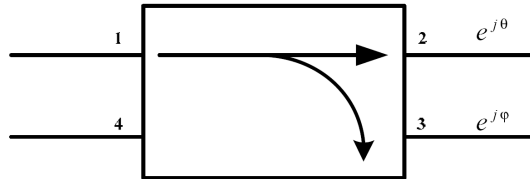

Figure 5. Symmetric/anti-symmetric coupler.

be a 3-port component as shown, with or without loss, or may be a four-port component [1, 9–13]. The 3-port networks take the form of T-junctions and other power dividers, while four-port networks take the form of directional couplers and hybrids. Power dividers are often of the half power type, but unequal power dividing ratios are also possible. Directional couplers can be designed for arbitrary power division, while hybrid junctions usually have equal power division. Hybrid junctions have either a 90° (quadrature) or a 180° (magic-T) phase shift between the output ports [1]. In recent years different designs of power divider/combiner are presented [14–24].

The scattering matrix of a 4-port coupler (Fig. 5) is:

$$S = \begin{pmatrix} 0 & \alpha & \beta e^{j\theta} & 0 \\ \alpha & 0 & 0 & \beta e^{j\varphi} \\ \beta e^{j\theta} & 0 & 0 & \alpha \\ 0 & \beta e^{j\varphi} & \alpha & 0 \end{pmatrix} \quad (15)$$

By choosing the proper values for parameters in (15) finally there are two options.

3.1. Symmetric/Anti-symmetric Couplers

The proper values and scattering matrix of symmetric/anti-symmetric coupler are shown in Table 1.

Using matched load at port 4 for each coupler, the final **S** matrixes

Table 1. Symmetric and anti-symmetric coupler.

Symmetric Coupler	Anti-symmetric Coupler
$\begin{cases} \alpha = \beta = 1/\sqrt{2} \\ \theta = \varphi = 90^\circ \end{cases}$	$\begin{cases} \alpha = \beta = 1/\sqrt{2} \\ \theta = 0^\circ, \varphi = 180^\circ \end{cases}$
$S_{\text{sym}} = 1/\sqrt{2} \begin{pmatrix} 0 & 1 & j & 0 \\ 1 & 0 & 0 & j \\ j & 0 & 0 & 1 \\ 0 & j & 1 & 0 \end{pmatrix}$	$S_{\text{anti-sym}} = 1/\sqrt{2} \begin{pmatrix} 0 & 1 & 1 & 0 \\ 1 & 0 & 0 & -1 \\ 1 & 0 & 0 & 1 \\ 0 & -1 & 1 & 0 \end{pmatrix}$

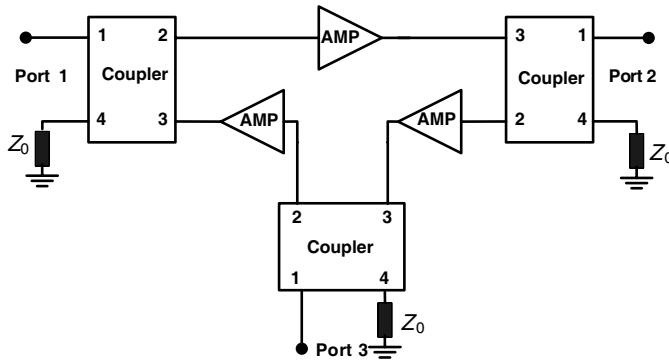

Figure 6. Basic configuration for active 3-port circulator.

are:

$$S_{\text{sym}} = 1/\sqrt{2} \begin{pmatrix} 0 & 1 & j \\ 1 & 0 & 0 \\ j & 0 & 0 \end{pmatrix} \tag{16}$$

$$S_{\text{anti-sym}} = 1/\sqrt{2} \begin{pmatrix} 0 & 1 & 1 \\ 1 & 0 & 0 \\ 1 & 0 & 0 \end{pmatrix} \tag{17}$$

In this design, by employing symmetric/anti-symmetric couplers and unilateral amplifiers, design of a 3-port active circulator is presented. The basic configuration for 3-port active circulator is shown in Fig. 6. As shown in Fig. 6, the incident signal at port 1 is divided into two signals. Because of unilateral characteristic of amplifier there is no signal at port 3 but amplified signal will appear at the input of power combiner at port 2. The inputs of power combiner are isolated, so the signal just appears at port 2. Also when the signal enters at ports 2 and 3, there is similar operation and finally the incident signal in each port, circulates to adjacent ports and non-adjacent ports are isolated. So we have an active circulator.

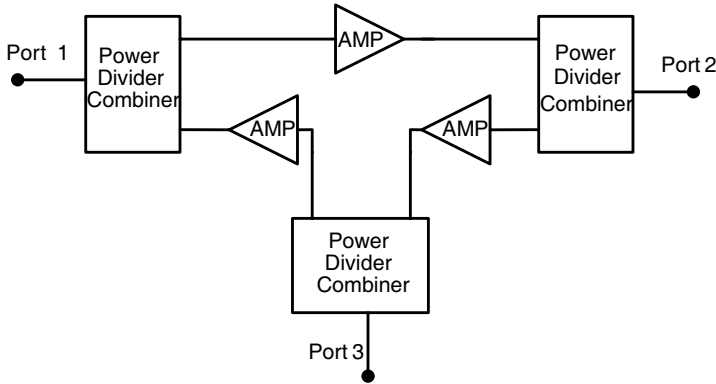

Figure 7. Active 3-port circulator.

3.2. Power Divider/combiner

By employing unilateral power divider/combiner and amplifiers, design of a 3-port active circulator will be described. For example, the scattering matrix of a Wilkinson power divider/combiner is [1]:

$$\mathbf{S} = j/\sqrt{2} \begin{pmatrix} 0 & 1 & 1 \\ 1 & 0 & 0 \\ 1 & 0 & 0 \end{pmatrix} \quad (18)$$

The block diagram of proposed active 3-port circulator is shown in Fig. 7. The incident signal at port 1 is divided into two signals of lesser power. Because of unilateral characteristic amplifier, there is no signal at port 3, but amplified signal will appear at the input of power combiner at port 2. The inputs of power combiner are isolated, so the signal just appears at port 2. When the signal enters at ports 2 and 3, there is similar operation, and finally we have an active circulator.

4. CONFIGURATION OF n -PORT ACTIVE CIRCULATOR

4.1. n -port Active Circulator Using Active Quasi Circulators

In this section we propose a configuration for n -port active circulator that employs quasi circulators (Fig. 8). Analytical equations are obtained for this n -port active circulator. For an n -port active circulator we need n quasi circulator modules.

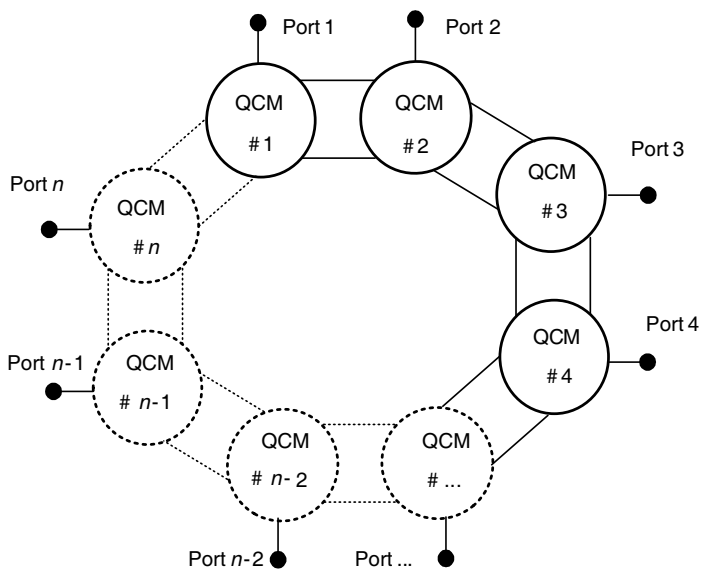

Figure 8. n -port active circulator.

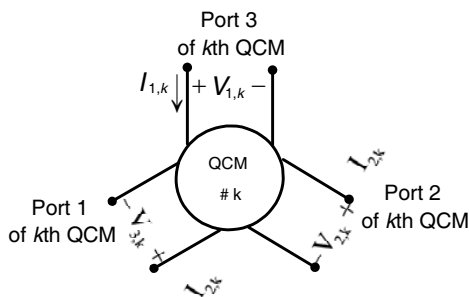

Figure 9. Port nomination of the k th quasi circulator.

Based on the port nomination used for this module in Fig. 9, $V_{1,k}$, $V_{2,k}$, $V_{3,k}$ and $I_{1,k}$, $I_{2,k}$, $I_{3,k}$ mean the port voltages and currents of the k th quasi circulator module.

On the other hand $I_{i,k}$, $V_{i,k}$ $i = 1, 2, 3$ for the k th quasi circulator that i is the number of quasi circulator ports. Also we know that the relation between currents and voltages for the k th quasi circulator is:

$$\begin{pmatrix} I_{1,k} \\ I_{2,k} \\ I_{3,k} \end{pmatrix} = \begin{pmatrix} a & 0 & 0 \\ b & c & 0 \\ d & b & e \end{pmatrix} \begin{pmatrix} V_{1,k} \\ V_{2,k} \\ V_{3,k} \end{pmatrix} \quad A = \frac{-d}{a+e}, \quad B = \frac{-b}{a+e} \quad (19)$$

By using supposed nomination in Fig. 9, the details of n -port active circulator are shown in Fig. 10.

Considering this configuration we obtained the admittance matrix, and then the scattering matrix will be obtained by converting this \mathbf{Y} matrix to \mathbf{S} .

$$\begin{pmatrix} I_{2,1} \\ I_{2,2} \\ \vdots \\ I_{2,k} \\ \vdots \\ I_{2,n-1} \\ I_{2,n} \end{pmatrix} = \begin{pmatrix} Y_{1,1} & Y_{1,2} & \cdot & Y_{1,k} & \cdot & Y_{1,n-1} & Y_{1,n} \\ Y_{2,1} & Y_{2,2} & \cdot & Y_{2,k} & \cdot & Y_{2,n-1} & Y_{2,n} \\ \vdots & \vdots & \ddots & \vdots & \vdots & \vdots & \vdots \\ Y_{k,1} & Y_{k,2} & \cdot & \cdot & \cdot & Y_{k,n-1} & Y_{k,n} \\ \vdots & \vdots & \ddots & \vdots & \vdots & \vdots & \vdots \\ Y_{n-1,1} & Y_{n-1,2} & \cdot & Y_{n-1,k} & \cdot & Y_{n-1,n-1} & Y_{n-1,n} \\ Y_{n,1} & Y_{n,2} & \cdot & Y_{n,k} & \cdot & Y_{n-1,n} & Y_{n,n} \end{pmatrix} \begin{pmatrix} V_{2,1} \\ V_{2,2} \\ \vdots \\ V_{2,k} \\ \vdots \\ V_{2,n-1} \\ V_{2,n} \end{pmatrix} \tag{20}$$

$$Y_{i,j} = \begin{cases} \frac{A^{n-1}Bb}{1 - A^n} + c & i = j \\ \frac{A^{n-1-i+j}Bb}{1 - A^n} & i > j \\ \frac{A^{j-i-1}Bb}{1 - A^n} & i < j \end{cases} \tag{21}$$

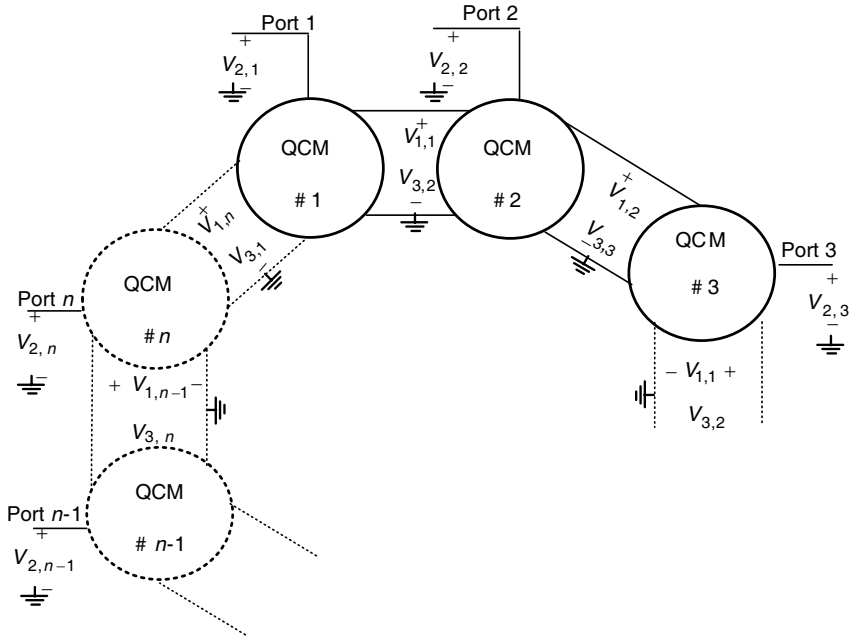

Figure 10. Schematic of n -port active circulator.

We can formulize the symmetry of this configuration that is shown in Fig. 8. For an n -port active circulator the analytic form of this symmetric configuration is:

$$\begin{cases} Y_{i,j} = Y_{i+1,j+1} & i \& j \neq n \\ Y_{i,n} = Y_{i+1,1} & j = n \\ Y_{n,j} = Y_{1,i+1} & i = n \end{cases} \quad (22)$$

Finally by substituting (19) to (21) we have:

$$Y_{i,j} = \begin{cases} \frac{-b^2(-d)^{n-1}}{(a+e)^n - (-d)^n} + c & i = j \\ \frac{-b^2(-d)^{n-1-i+j}}{((a+e)^n - (-d)^n)(a+e)^{j-i}} & i > j \\ \frac{-b^2(-d)^{j-i-1}(a+e)^{n-j+i}}{(a+e)^n - (-d)^n} & i < j \end{cases} \quad (23)$$

The Equation (23) defines the final relation for admittance matrix. Also by using $\mathbf{S} = (\mathbf{Y} + \mathbf{Y}_0)^{-1}(\mathbf{Y}_0 - \mathbf{Y})$, the scattering matrix will be obtained from admittance matrix. The result is:

$$S_{n\text{-port}} = \begin{pmatrix} S_{1,1} & S_{1,2} & S_{1,3} & \cdot & \cdot & S_{1,n-1} & S_{1,n} \\ S_{1,n} & S_{1,1} & S_{1,2} & \cdot & \cdot & S_{1,n-2} & S_{1,n-1} \\ S_{1,n-1} & S_{1,n} & S_{1,1} & \cdot & \cdot & S_{1,n-3} & S_{1,n-2} \\ \cdot & \cdot & \cdot & \cdot & \cdot & \cdot & \cdot \\ \cdot & \cdot & \cdot & \cdot & \cdot & \cdot & \cdot \\ S_{1,3} & S_{1,4} & S_{1,5} & \cdot & \cdot & S_{1,1} & S_{1,2} \\ S_{1,2} & S_{1,3} & S_{1,4} & \cdot & \cdot & S_{1,n} & S_{1,1} \end{pmatrix} \quad (24)$$

4.2. n -port Active Circulator Using Extended form of Proposed 3-Port Active Circulators

Here, the block diagram of an active n -port circulator is illustrated in Fig. 11. This structure is the extended form of proposed configuration in Fig. 6 for n -port active circulator. As described, the circulation between adjacent ports is similar to the principles in Fig. 6.

Also by connecting power divider/combiner and unilateral amplifiers an active n -port circulator will be obtained. This structure is the extended form of proposed configuration in Fig. 7, for n -port active circulator. The block diagram of active n -port circulator is shown in Fig. 12. As described, the circulation between adjacent ports is similar to the principles in Fig. 7.

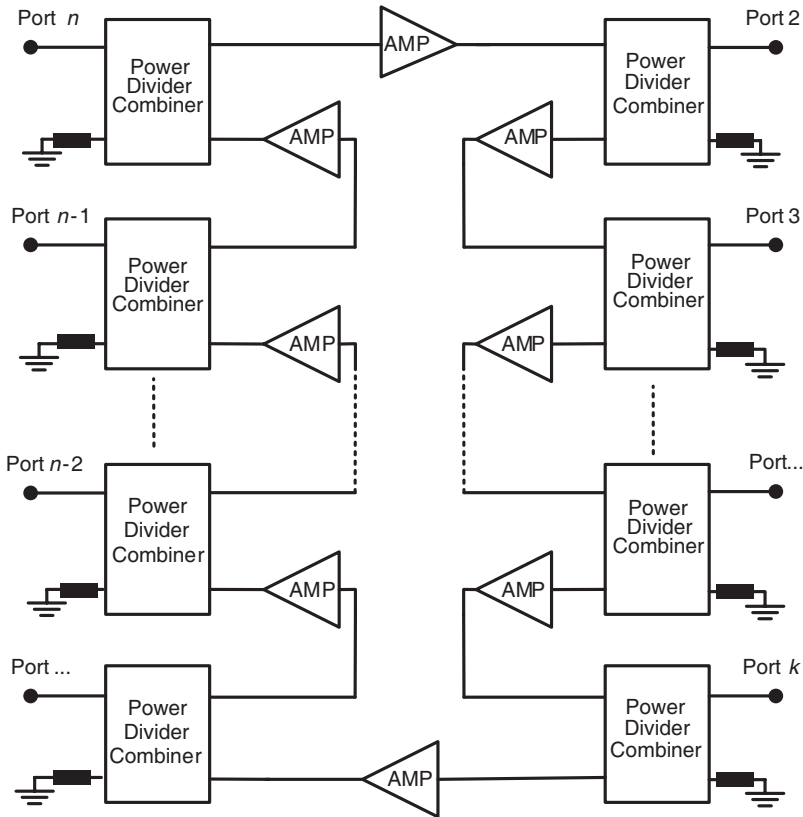

Figure 11. Block diagram of active n -port circulator.

5. SIMULATION RESULTS OF ACTIVE QCMS AND ACTIVE CIRCULATORS

In this part, the simulation of active quasi circulator circuits and circulator, with the configuration shown in Figs. 2, 6 and 7, are presented. In this case, the power divider/combiner and symmetric/anti-symmetric coupler are supposed to be ideal and a designed distributed amplifier is used. As distributed amplifiers are gaining popularity in microwave broadband integration circuits applications, a variant of the distributed amplifier has recently been described [25–29]. They have inherently large gain-bandwidth and are suitable choice for our proposed active quasi circulator modules. The distributed amplifier that can be implemented by MMIC technology is a suitable circuit for wideband applications. This designed distributed amplifier is broadband (1–30 GHz).

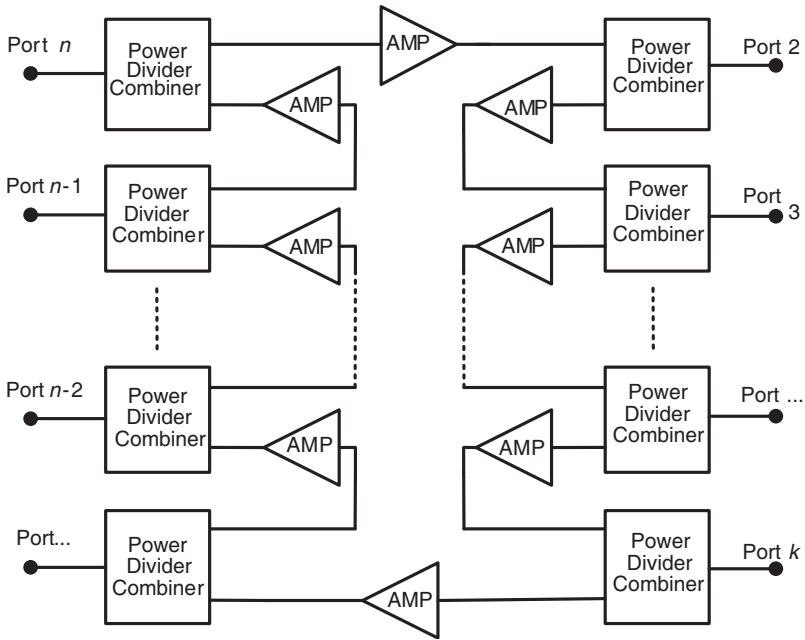

Figure 12. Active n -port circulator.

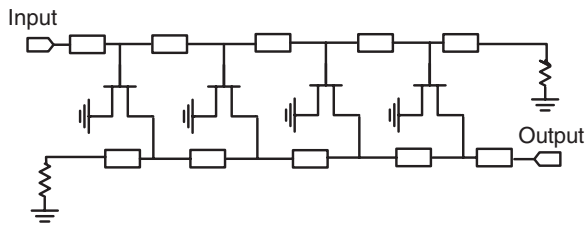

Figure 13. Configuration of the distributed amplifier.

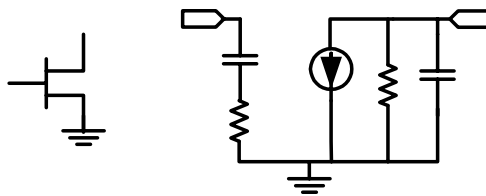

Figure 14. Unilateral model used for HEMT.

The configuration of the employed distributed amplifier is shown in Fig. 13. The unilateral model used for HEMT transistors is shown in Fig. 14. The simulated S -parameters of this distributed amplifier are shown in Fig. 15. The advantages of this amplifier will affect the output of proposed quasi circulators. The results of the designed quasi circulators show a relatively flat transmission coefficient over several octaves and a good return loss.

The results of the proposed active quasi circulators and active 3-port circulators, employing the designed distributed amplifier, are shown in Figs. 16–18 which show a relatively flat transmission coefficient over several octaves and a good return loss.

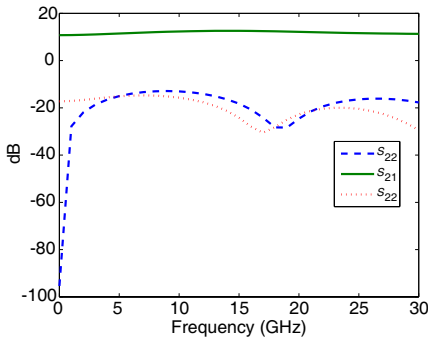

Figure 15. Simulation results of the distributed amplifier.

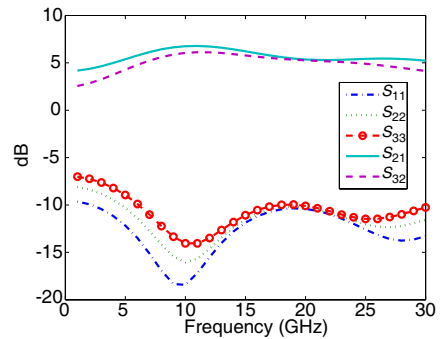

Figure 16. S -parameters of active quasi circulator designed by out-of-phase power divider.

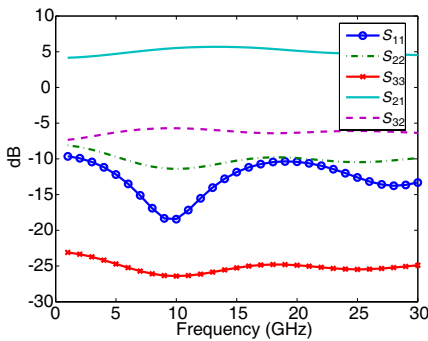

Figure 17. S -parameters of active quasi circulator designed by out-of-phase power combiner.

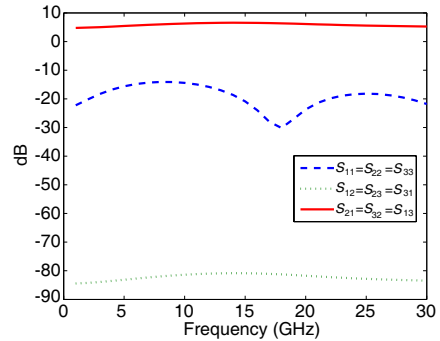

Figure 18. S -parameters of active circulator designed by 90° coupler.

6. CONCLUSION

In this paper, novel active quasi circulators and active circulators have been proposed using power divider/combiner, symmetric/anti-symmetric couplers and general unilateral amplifiers. These proposed active quasi circulator and active circulator circuits are the results of the modular design approaches. In these circuits, a distributed amplifier is employed to construct the proposed active quasi circulator module and active circulators. Based on the proposed block diagrams, detailed designs of n -port active circulator have been presented. The simulation result of designed active quasi circulators and active circulators show that the gain, isolation and return loss of these modules are better than those of other modules.

REFERENCES

1. Pozar, D. M., *Microwave Engineering*, 2nd edition, Wiley, New York, 1998.
2. Tanaka, S., N. Shimomura, and K. Ohtake, "Active circulators — The realization of circulators using transistors," *Proc. IEEE*, Vol. 53, 260–267, Mar. 1965.
3. Smith, M., "GaAs monolithic implementation of active circulators," *IEEE MTT-S Int. Microwave Symp. Digest*, 1015–1015, May 1988.
4. Hara, S., T. Tokumitsu, and M. Aikawa, "Novel unilateral circuits for MMIC circulators," *IEEE Trans. Microw. Theory Technol.*, Vol. 38, No. 8, 1399–1406, 1990.
5. Bahl, J., "The design of a 6-port active circulator," *IEEE MTT-S Int. Microwave Symp. Digest*, 1011–1014, May 1988.
6. Cryan, M. and P. S. Hall, "An integrated active circulator antenna," *IEEE Microw. Guided Wave Lett.*, Vol. 7, No. 6, 190–191, 1997.
7. Saavedra, C. E. and Y. Zheng, "Active quasi-circulator realization with gain elements and slow-wave couplers," *IET Microw. Antennas Propag.*, Vol. 1, No. 4, 1020–1023, 2007.
8. Razavipour, H., R. Saan, G. Askari, F. Fesharaki, and H. M. Sadeghi, "A new dual band high power ferrite circulator," *Progress In Electromagnetics Research C*, Vol. 10, 15–24, 2009.
9. Li, Z. and T. J. Cui, "Novel waveguide directional couplers using left handed materials," *Journal of Electromagnetic Waves and Applications*, Vol. 21, No. 8, 1053–1062, 2007.
10. Nedil, M. and T. A. Denidni, "Analysis and design of an

- ultra wideband directional coupler,” *Progress In Electromagnetics Research B*, Vol. 1, 291–305, 2008.
11. Wang, E. C., S. J. Fang, M. J. Fan, and P. Chen, “FDTD analysis of a novel 8 mm-*E* plane junction waveguide circulator,” *Journal of Electromagnetic Waves and Applications*, Vol. 21, No. 14, 1951–1958, 2007.
 12. Ramesh, M., D. Packiaraj, and A. T. Kalghatgi, “A compact branch line coupler using defected ground structure,” *Journal of Electromagnetic Waves and Applications*, Vol. 22, Nos. 2–3, 267–276, 2008.
 13. Shamsinejad, S., M. Soleimani, and N. Komjani, “Novel enhanced and miniaturized 90-deg coupler for 3G mixers,” *Progress In Electromagnetics Research Letters*, Vol. 3, 43–50, 2008.
 14. Chang, C.-P., C.-C. Su, S.-H. Hung, and Y.-H. Wang, “Unequal Wilkinson power divider with EBG CPW,” *Progress In Electromagnetics Research Letters*, Vol. 8, 151–159, 2009.
 15. Guo, Y., Y. Xu, L. Xia, and R. Xu, “Efficient optimization of a Ka band branch waveguide power divider,” *Journal of Electromagnetic Waves and Applications*, Vol. 22, No. 1, 17–26, 2008.
 16. Guo, Y. and R. Xu, “Ultra wideband power slitting/combining techniques using zero-degree left handed transmission lines,” *Journal of Electromagnetic Waves and Applications*, Vol. 21, No. 8, 1109–1118, 2007.
 17. Zhang, J., B. Cui, J.-Z. Gu, and X.-W. Sun, “A harmonic suppressed Wilkinson power divider using complementary split ring resonator (CSRRS),” *Journal of Electromagnetic Waves and Applications*, Vol. 21, No. 6, 811–819, 2007.
 18. Lin, X. Q., Q. Cheng, R. P. Liu, D. Bao, and T. J. Cui, “Compact resonator couplers and power dividers designed with simplified meta structures,” *Journal of Electromagnetic Waves and Applications*, Vol. 21, No. 12, 1663–1672, 2007.
 19. Yang, T., C. Liu, L. Yan, and K. Huang, “A compact dual-band power divider using planar artificial transmission lines for GSM/DCS applications,” *Progress In Electromagnetics Research Letters*, Vol. 10, 185–191, 2009.
 20. Shamsinejad, S., M. Soleimani, and N. Komjani, “Novel miniaturized Wilkinson power divider for 3G mobile receivers,” *Progress In Electromagnetics Research Letters*, Vol. 3, 9–16, 2008.
 21. Fan, F., Z. Yan, and J. Jiang, “Design of a novel compact power divider with harmonic suppression,” *Progress In Electromagnetics*

- Research Letters*, Vol. 5, 151–157, 2008.
22. Hee-Tae, A. and D. Allstot, “A 0.5–8.5 GHz fully differential CMOS distributed amplifier,” *IEEE J. Solid-state Circuits*, Vol. 37, No. 6, 985–993, Jun. 2000.
 23. Liu, R.-C., C.-S. Lin, K.-L. Deng, and H. Wang, “A 0.5–14-GHz 10.6-dB CMOS cascade distributed amplifier,” *Proc. IEEE VLSI Circuits Symp.*, 139–140, 2003.
 24. Amaya, R. E., N. Tam, and C. Plett, “A 27 GHz fully integrated CMOS distributed amplifier using coplanar waveguides,” *Proc. IEEE Radio Freq. Integr. Circuits (RFIC) Symp.*, Vol. 1, 193–196, 2004.
 25. Liu, R.-C., K.-L. Deng, and H. Wang, “A 0.6–22-GHz broadband CMOS distributed amplifier,” *Proc. IEEE Radio Freq. Integr. Circuits (RFIC) Symp.*, 103–106, 2003.
 26. Wang, T., C.-H. Chen, Y.-S. Lin, and S.-S. Lu, “A micromachined CMOS distributed amplifier by CMOS compatible ICP deep-trench technology,” *IEEE Electron Device Lett.*, Vol. 27, No. 4, 291–293, 2006.
 27. Tsai, M., H. Wang, J. Kuan, and C. Chang, “A 70 GHz cascaded multistage distributed amplifier in 90 nm CMOS technology,” *Proc. Int. Solid-state Conf.*, Vol. 1, 402–403, 2005.
 28. Chu, S. L. G., Y. Tajima, J. B. Cole, A. Platzker, and M. J. Schindler, “A novel 4–18 GHz monolithic matrix distributed amplifier,” *IEEE MTT-S Int. Microwave Symp. Dig.*, 291–295, Jun. 1989.
 29. Wang, T., C.-H. Chen, Y.-S. Lin, and S.-S. Lu, “A micromachined CMOS distributed amplifier by CMOS compatible ICP deep-trench technology,” *IEEE Electron Device Lett.*, Vol. 27, No. 4, 291–293, 2006.