

01 Mar 2005

## Analysis and Design of Switched Capacitor Converters

Jonathan W. Kimball

Missouri University of Science and Technology, kimballjw@mst.edu

Philip T. Krein

Follow this and additional works at: [https://scholarsmine.mst.edu/ele\\_comeng\\_facwork](https://scholarsmine.mst.edu/ele_comeng_facwork)



Part of the [Electrical and Computer Engineering Commons](#)

---

### Recommended Citation

J. W. Kimball and P. T. Krein, "Analysis and Design of Switched Capacitor Converters," *Proceedings of the 20th Annual IEEE Applied Power Electronics Conference and Exposition (2005, Austin, TX)*, vol. 3, pp. 1473-1477, Institute of Electrical and Electronics Engineers (IEEE), Mar 2005.

The definitive version is available at <https://doi.org/10.1109/APEC.2005.1453227>

This Article - Conference proceedings is brought to you for free and open access by Scholars' Mine. It has been accepted for inclusion in Electrical and Computer Engineering Faculty Research & Creative Works by an authorized administrator of Scholars' Mine. This work is protected by U. S. Copyright Law. Unauthorized use including reproduction for redistribution requires the permission of the copyright holder. For more information, please contact [scholarsmine@mst.edu](mailto:scholarsmine@mst.edu).

# Analysis and Design of Switched Capacitor Converters

Jonathan W. Kimball, *Member*      Philip T. Krein, *Fellow*

Grainger Center for Electric Machinery and Electromechanics  
University of Illinois at Urbana-Champaign  
1406 W. Green St., Urbana, IL 61801 USA

**Abstract** – Switched capacitor converters have become more common in recent years. Crucial to understanding the maximum power throughput and efficiency is a model of the converter's equivalent resistance. A new form for equivalent resistance is derived and discussed in a design context. Quasi-resonant operation is also explored and compared to non-resonant operation. Several capacitor technologies are evaluated and compared.

## I. INTRODUCTION

Switched capacitor (SC) converters have gained in popularity in recent years [1], and are being applied at increasing power levels. As performance requirements increase, an understanding of the limitations of an SC converter is necessary for effective design.

SC converters are significantly different from power converters that use magnetic energy storage. Fundamentally, SC converters have equivalent resistance that determines their performance, and is generally much higher than the output impedance of a converter that uses inductance to store energy. Several methods are available for output voltage control. The traditional methods given in [2]-[3] use duty cycle control, which effectively increases the converter's equivalent resistance. Duty cycle control relies on the load pulling the output voltage down, creating a voltage divider between a Thevenin equivalent resistance and the load. When load varies significantly, more sophisticated techniques are necessary to effectively control the output voltage [4].

Design of an SC converter requires an understanding of the technology trade-offs involved. A wide variety of capacitors are available, from aluminum electrolytic through various types of solid dielectric to film and ceramic. Each technology has a relevant field of use, depending on its loss characteristics. Capacitor technology choice is particularly important for high power converters, such as proposed in [5] for 14 V-to-42 V conversion.

A reasonable alternative that should be explored is a quasi-resonant converter. In this case, a typical SC topology is used, but the capacitor is replaced by a series LC tank. If the resonant frequency can be tracked, there is potential for increased performance. The analysis of this topology has implications for standard SC converters when one considers that all capacitors have some inductance, so all SC converters can ultimately be driven in a quasi-resonant fashion. In [6], a quasi-resonant converter is shown to achieve ideal efficiency, in contrast to an SC converter, which has a minimum equivalent resistance due to capacitor impedance.

In this paper, the focus is power conversion. Previous work [7] has performed similar analysis in the context of analog filter applications, with correspondingly different approaches and results. The focus is on steady-state operation, not small-signal dynamics, so the modeling methodology differs from [8]-[9].

## II. MODEL DERIVATION

A simplified switched capacitor converter is shown in Fig. 1. More sophisticated converters are generally composed of  $n$  cells that are each topologically equivalent to this fundamental building block. For example, a battery equalization circuit [10] motivated the current work. In the equalizer, the two voltage sources are two batteries in series, and four total switches (rather than two) are required to make the necessary connections. This topological shifting is immaterial, provided all losses are accounted for. Loss elements are included in each switch and in the capacitor (equivalent series resistance, or ESR). Only resistance is included; if one switch element includes a diode, its forward drop would affect the Thevenin equivalent voltage, but not the equivalent resistance. Not shown are the resistances of all of the traces, which would be lumped into one of the three resistors shown. The capacitor voltage,  $V_c$ , shown in Fig. 1 is idealized and not measurable, since the ESR is internal to the component.

The idealized capacitor charges during one half cycle and discharges during the other half cycle. The charge and discharge follow exponential characteristics. In periodic steady state,  $V_c$  at the start of the charge cycle is equal to  $V_c$  at the end of the discharge cycle,  $V_{c2}$ . Similarly,  $V_c$  at the start of

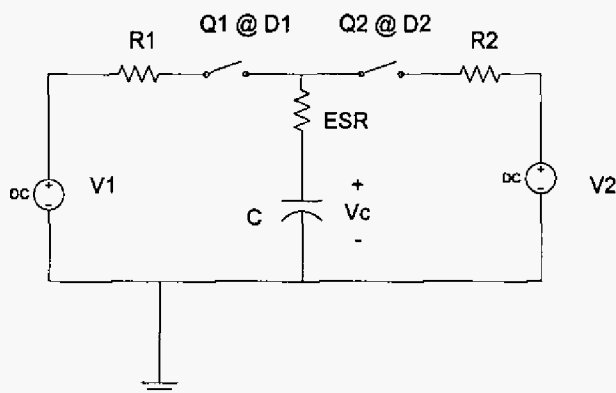

Fig. 1. Simplified SC cell format. Switching functions and duty ratios are shown.

the discharge cycle is equal to  $V_c$  at the end of the charge cycle,  $V_{c1}$ . The capacitor is charged and discharged in one period,  $T$ . This yields

$$V_{c1} - V_{c2} = (V_1 - V_2) \frac{\left(\exp\left(\frac{D_1 T}{\tau_1}\right) - 1\right) \left(\exp\left(\frac{D_2 T}{\tau_2}\right) - 1\right)}{\left(\exp\left(\frac{D_1 T}{\tau_1} + \frac{D_2 T}{\tau_2}\right) - 1\right)} \quad (1)$$

$$\tau_1 = (R_1 + ESR)C$$

$$\tau_2 = (R_2 + ESR)C$$

The current delivered by a capacitor that is charged and discharged through this voltage change is

$$i = fC(V_{c1} - V_{c2})$$

$$f = \frac{1}{T} \quad (2)$$

The combination of (1) and (2) gives

$$R_{eq} = \frac{V_1 - V_2}{i} = \frac{1}{fC} \frac{\left(\exp\left(\frac{D_1 T}{\tau_1} + \frac{D_2 T}{\tau_2}\right) - 1\right)}{\left(\exp\left(\frac{D_1 T}{\tau_1}\right) - 1\right) \left(\exp\left(\frac{D_2 T}{\tau_2}\right) - 1\right)} \quad (3)$$

For duty cycle control, typically  $T$  is fixed,  $D_2$  is fixed at or near 50%, capacitor and resistor values are fixed by construction, and  $D_1$  is varied to control the output voltage. This result is similar to that of [11].

Fig. 2 shows the effect of  $D_1$  on the equivalent resistance of a typical converter. As  $D_1$  varies from 2% to 50%, equivalent resistance varies by approximately one order of magnitude. Clearly this technique would be effective for most loads, but not for loads that vary over a wide range.

The equivalent resistance given by (3) is useful for the general case. Often, however, SC converters are used as voltage doublers to provide a bias potential. In this case,  $D_1$  and  $D_2$  are both fixed, typically both set as close to 50% as possible without creating shoot-through conditions. The

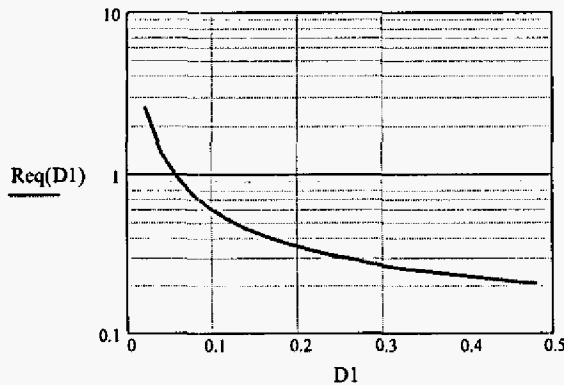

Fig. 2. Equivalent resistance of duty-cycle controlled SC converter.

resistances are nearly equal, so  $\tau_1$  and  $\tau_2$  are nearly equal. Using these simplifying assumptions, a new form of equivalent resistance can be found:

$$R_{eq} = \frac{1}{fC} \frac{1 + \exp\left(-\frac{DT}{\tau}\right)}{1 - \exp\left(-\frac{DT}{\tau}\right)} \quad (4)$$

This simplified form can be used for limit studies.

### III. QUASI-RESONANT SC CONVERTERS

For some applications requiring a voltage doubler function, one might be curious about a quasi-resonant approach. For example, the battery equalizer of [10] approximates voltage doubler behavior, and low equivalent resistance is paramount to effective equalization. Quasi-resonant operation requires the simplifying assumptions given above: equal resistances, equal duty cycles.

The circuit to be analyzed is shown in Fig. 3. In this case, Fourier analysis can be used to determine equivalent resistance. The applied voltage is a quasi-square wave with magnitude  $\frac{V_1 - V_2}{2}$ . The fundamental component is

$$b_1 = \frac{2}{\pi} \sin(\pi D)(V_1 - V_2) \quad (5)$$

If the quality factor

$$Q = \frac{2\pi fL}{R} \quad (6)$$

is high, the fundamental current dominates. For optimal operation, the circuit should be driven at

$$f = \frac{\pi}{D} \sqrt{LC} \quad (7)$$

At this excitation frequency, the current reaches zero at the end of each charge/discharge cycle. The charge delivered to the capacitor is the integral of the current and is inversely

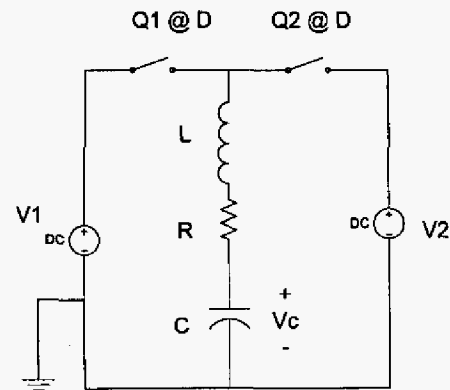

Fig. 3. Quasi-resonant SC converter.

proportional to frequency. The equivalent resistance is determined by the voltage difference, the charge delivered per cycle, and the frequency, such that

$$R_{eq} = \frac{\pi^2 R}{2 \sin(\pi D)}. \quad (8)$$

This form can be used for comparison to traditional SC converters.

#### IV. LIMITS ON PERFORMANCE

The basic voltage doubler with no inductance has an equivalent resistance given by (4). In the limit as frequency is increased,

$$R_{eq,lim} = \lim_{f \rightarrow \infty} R_{eq} = \frac{2R}{D}. \quad (9)$$

Since duty cycle is limited to 50%, the lowest possible equivalent resistance is 4R.

Depending on capacitor technology, the circuit may not operate properly at very high frequencies. For example, standard electrolytic capacitors have substantial inductance and ESR that increases with frequency. One might ask, at what frequency is  $R_{eq}$  some multiple  $k$  of  $R_{eq,lim}$ ? Unfortunately, no analytical solution exists owing to the transcendental nature of (4). A numerical solution can be found for a particular value of  $k$ . For example, for  $k=2$ ,

$$f = \frac{3.83D}{\tau}. \quad (10)$$

Clearly the relevant operating frequency is related to the circuit time constant, which becomes one figure of merit for evaluating capacitor technologies. Depending on the situation, a designer may desire a slow circuit time constant, allowing one type of gate drive and low operating frequency, or a fast circuit time constant, requiring a different kind of gate drive and high frequency techniques but potentially reducing converter size.

An idealized (resistor-free) switched capacitor converter has an equivalent resistance given by

$$R_{ideal} = \frac{1}{fC} \quad (11)$$

A designer may ask at what frequency does  $R_{eq} = kR_{ideal}$ ? This condition determines where the designer must consider the parasitic resistances:

$$f = \frac{D}{\tau \ln\left(\frac{k+1}{k-1}\right)} \quad (12)$$

For  $k=2$ , this frequency is  $f = \frac{D}{1.1\tau}$ .

A typical SC converter may operate at 45% to avoid shoot-through conditions. Then its equivalent resistance, at infinite frequency, is  $R_{SC} = 4.444R$ . A quasi-resonant converter operated at 45% and at the correct frequency has an equivalent resistance of  $R_{QR} = 4.996R$ . The decision between the two converter types is not quite obvious. On the one hand, a simple SC converter has greater potential for low equivalent resistance. When one considers the resistance of the inductor in the quasi-resonant converter, the SC advantage appears to be even greater. On the other hand, it is often difficult to realize the full potential of an SC converter, given the limits on operating frequency discussed above. There are potential situations where adding inductance and operating in quasi-resonance will yield maximum performance. Operation in quasi-resonance likely requires an active tuning controller owing to the high Q necessary for low equivalent resistance.

#### V. IMPLICATIONS FOR DESIGN

To be a valuable design tool, the new model must first be verified as generally correct, then shown to match a design specification. In Fig. 4, three curves are shown for a 30  $\mu$ F polyester film capacitor. One curve is the simple idealized model traditionally used, as given by (11). This simple model works well at low frequencies but at higher frequencies, resistance begins to dominate. Another curve is the limit given by (9). The solid curve is the actual measured equivalent resistance. At high frequencies, the equivalent resistance begins to increase again. Most likely, this effect is caused by inductance in the circuit (a low Q response). The shape of Fig. 4 resembles a curve in [12], which was presented without explanation.

Designers must consider two parameters when choosing capacitor technology: ESR and  $\tau$ . For some sample capacitors that are approximately the same physical size, values for C,

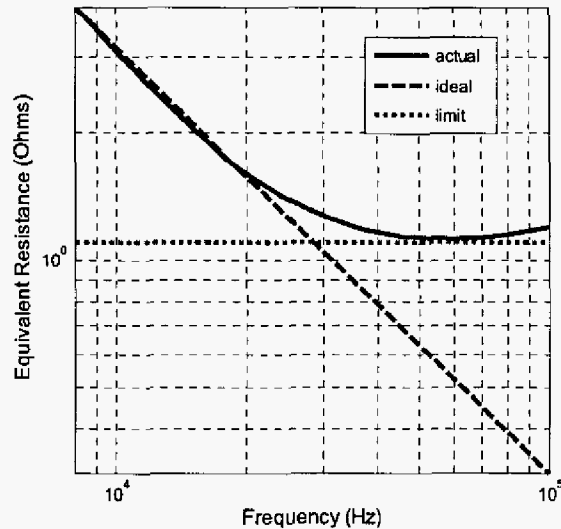

Fig. 4. Measured vs. limiting performance for a 30  $\mu$ F SC converter.

TABLE 1. COMPARISON OF CAPACITOR TECHNOLOGIES.

Capacitor Type	Value ( $\mu\text{F}$ )	Voltage (V)	ESR ( $\text{m}\Omega$ )	$\tau$ ( $\mu\text{s}$ )
Aluminum Electrolytic	156	25	100	15.6
Tantalum	44.1	20	208	9.2
Ceramic	7.03	50	22.5	0.16
Polyester	2.14	50	81.2	0.17
Aluminum Polymer	181	20	17.5	3.2

ESR, and  $\tau$  are given in Table 1. If performance is the only criterion, polymer electrolytic types appear to have an advantage. First, the measured capacitor has the lowest ESR in this group, although the margin is not large. Second, the polymer electrolytic has a moderate time constant, allowing operation at a moderate frequency.

In general, there are three physical phenomena determining component ESR. Most designers consider the dielectric losses of a typical parallel plate construction. These losses are low in ceramic capacitors and very low in film capacitors. All capacitors require plate metallization and leads. Table 1 suggests that the resistance of the leads and plates dominates ESR for ceramic, film, and polymer electrolytic capacitors. This would explain the relatively small differences between these three technologies. Traditional electrolytic devices, including tantalum, experience another loss term, the resistance of the electrolyte. This pushes their ESR up another order of magnitude.

Missing from the model of Fig. 1 but present in a real converter is a bypass capacitor. The effect of the bypass capacitor depends on the characteristics of the source and load. If the source and load display ideal voltage source characteristics at the switching frequency, then the bypass capacitor is not necessary and has no effect. If the source and load display ideal current source characteristics at the switching frequency owing to inductance, then the ESR of the bypass capacitor adds to the switch resistance. Real sources fall between these ideal extremes, so the real equivalent resistance will include a fraction of bypass capacitor ESR. A conservative design technique is to assume current source characteristics.

The designer must recognize other sources of resistance in the circuit. Sometimes capacitor ESR will dominate, but only if other circuit components are chosen properly. MOSFET  $R_{ds(on)}$  must be minimized, but generally  $R_{ds(on)}$  reduction adds cost. Often, a good system design will have equal contributions from ESR and  $R_{ds(on)}$ . Trace resistance can also be significant. A trace 2.5 mm wide, 25 mm long, in 1 oz/ft<sup>2</sup> copper has series resistance of 5 m $\Omega$ , which can be significant. Low inductance layout techniques are necessary to avoid low Q resonance phenomena.

ESR and other resistance sources dictate a floor on the achievable equivalent resistance. For a given choice of device technology, the designer's task of reducing the minimum

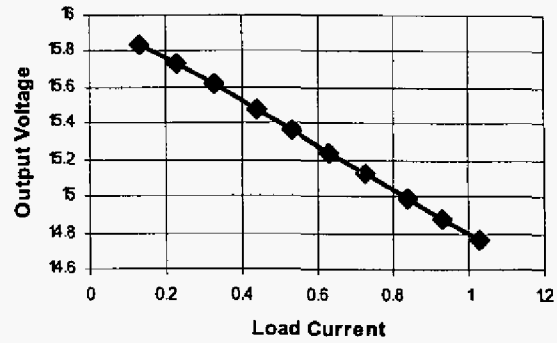

Fig. 5. Measured load regulation for example SC converter.

equivalent resistance can be exceedingly difficult. For example, one may choose to parallel several capacitors and several MOSFETs to achieve a particular resistance. However, each additional component requires additional copper traces and leads, and can increase system inductance. A promising alternative to study is paralleling complete converters, rather than paralleling components.

An SC converter was designed and built based on the analysis here to validate the concepts. The specification is a doubler with an input voltage of 8.0 V that is to generate a minimum 15.0 V output for load current up to 0.8 A. The required equivalent resistance is not to exceed 1.25  $\Omega$ . For simplicity of control, the upper devices were chosen to be p-channel MOSFETs (IRF5210, 60 m $\Omega$ ) while the lower devices were chosen to be n-channel MOSFETs (IRF540, 62 m $\Omega$ ). The polymer electrolytic 180  $\mu\text{F}$  capacitor listed in Table 1 is used for both the flying capacitor and bypass capacitor. This gives a total ESR contribution of 35 m $\Omega$ . Allowing for 10 m $\Omega$  of trace resistance, total parasitic resistance is 167 m $\Omega$ . The limiting equivalent resistance is 835 m $\Omega$ . Capacitor values are specified as  $\pm 20\%$ , so the design target is 1.05  $\Omega$  equivalent resistance. From (12), a minimum switching frequency of 7.34 kHz is found; 7.5 kHz was chosen for convenience. The circuit was built and tested. The output regulation is shown in

Fig. 5. Calculated output resistance is 1.2  $\Omega$ , which satisfies the specification even though it is slightly higher than the computed value.

Frequently, SC converters are categorically described as having poor input current waveforms, in the form of impulses. In a signal processing application, this characterization can be true, as the switching frequency is specifically chosen to be well below the point where resistance matters. Power converters, though, operate at much higher relative frequencies to provide maximum power throughput (minimum equivalent resistance). In this case, current in the capacitor is not impulsive, and indeed approaches a square wave or even a triangle, with decay during the high and low times. So long as adequate input bypass capacitance is provided, input current

waveforms resemble those of a buck converter. For the experimental converter, the gate signal for the input switch and the input current are shown in Fig. 6. The input current is indeed nearly triangular. Significant ripple is present, but the peak input current is only 167% of the average and the waveform is smooth with minimal high frequency content.

## VI. CONCLUSION

Models for the performance of an SC converter and quasi-resonant SC converter have been derived. At high frequency, resistance dominates, causing deviation from the ideal equivalent resistance expected. Resistance effects have important implications for high-power or high-performance SC converters. A design has been demonstrated that uses the new models to predict converter performance.

## REFERENCES

- [1] A. Ioinovici, "Switched-capacitor power electronics circuits," *IEEE Circuits and Systems Magazine*, vol. 1, issue 3, pp. 37-42, 2001.
- [2] G. Zhu, H. Wei, I. Batarseh, A. Ioinovici, "A new switched-capacitor dc-dc converter with improved line and load regulations," in *Proc. IEEE International Symp. Circuits and Systems*, 1999, pp. 234-237.
- [3] S. V. Cheong, H. Chung, A. Ioinovici, "Inductorless DC-to-DC converter with high power density," *IEEE Trans. Industrial Electronics*, vol. 41, pp. 208-215, Apr. 1994.
- [4] H. Chung, B. O, A. Ioinovici, "Switched-capacitor-based DC-to-DC converter with improved input current waveform," in *Proc. IEEE International Symp. Circuits and Systems*, 1996, pp. 541-544.
- [5] F. Z. Peng, F. Zhang, Z. Qian, "A magnetic-less DC-DC converter for dual-voltage automotive systems," *IEEE Trans. Industry Applications*, vol. 39, pp. 511-518, March-April 2003.
- [6] P. Midya, "Efficiency analysis of switched capacitor doubler," in *Proc. IEEE Midwest Symp. Circuits and Systems*, 1996, pp. 1019-1022.
- [7] H. Jokinen, M. Valtonen, "Small-signal analysis of nonideal switched-capacitor circuits," in *Proc. IEEE International Symp. Circuits and Systems*, 1994, pp. 395-398.
- [8] H. Jokinen, M. Valtonen, "Steady-state small-signal analysis of switched-capacitor circuits," in *Proc. Midwest Symp. Circuits and Systems*, 1996, pp. 381-384.
- [9] H. S. H. Chung, "Development of DC/DC regulators based on switched-capacitor circuits," in *Proc. IEEE International Symp. Circuits and Systems*, 1999, pp. 210-213.
- [10] C. Pascual, P. T. Krein, "Switched capacitor system for automatic series battery equalization," in *Proc. IEEE Applied Power Electronics Conf.*, 1997, pp. 848-854.
- [11] G. Zhu, A. Ioinovici, "Switched-capacitor power supplies: DC voltage ratio, efficiency, ripple, regulation," in *Proc. IEEE International Symp. Circuits and Systems*, 1996, pp. 553-556.
- [12] M. S. Makowski, D. Maksimovic, "Performance limits of switched-capacitor DC-DC converters," in *Rec., IEEE Power Electronics Specialists Conf.*, 1995, pp. 1215-1221.

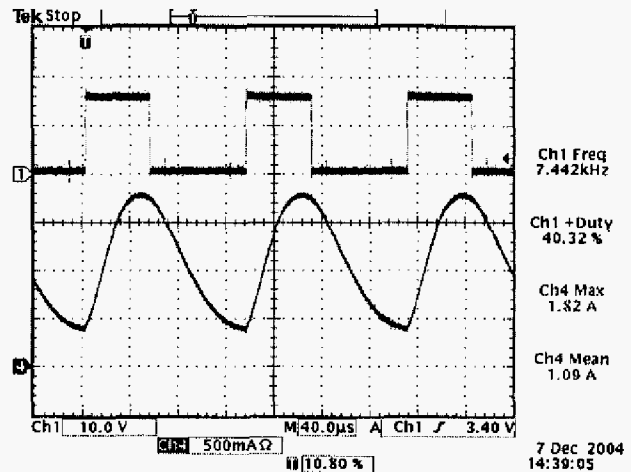

Fig. 6. Gate voltage (Channel 1, 10 V/div) and input current (Channel 4, 500 mA/div) for example SC converter. Horizontal 40  $\mu$ s/div.