

UDC 621.777

Analysis of energy-force parameters of combined processing for receiving modifying bars from Al-5Ti-1B alloy

Sidelnikov SB, Galiev RI, Lopatina ES, Samchuk AP

Siberian Federal University, Krasnoyarsk

E-mail: sbs270359@yandex.ru

The results of theoretical and experimental research of energy-force parameters of the combined rolling-extrusion process (CRE) and combined casting and rolling-extrusion process (CCRE) of Al-5Ti-1B alloy bars are presented. It is proved that bars from this alloy have turned out to be the most effective modifiers for obtaining ingots from aluminum alloys, having fine-grained structure and the required level of mechanical properties. It's become obvious, that the existing manufacturing process of long-dimensioned deformed semi-finished products performed at casting-rolling equipment and horizontal hydraulic extrusion press does not always give an opportunity to obtain high-quality products due to the appearance of cracks in the process of rolling, and increased energy-power loading of the equipment. New technologies of combined processing (CRE and CCRE) have been proposed. These technologies allow to reduce significantly the energy-force parameters of processing by means of using active frictional forces when combining casting, rolling and extrusion. According to the proposed formulas, the forces influencing the matrix and rolls during the combined processing have been calculated. These results have been compared to the experimental data, thus, the calculated and experimental data are of satisfactory convergence. Metallographic analysis of the structure of bars obtained by means of various methods of combined processing has been carried out. It has been pointed out, that the CCRE method gives an optimal arrangement and the range of intermetallic phases, while the particles are evenly distributed over the cross-section and are dispersed. The results of the tests of mechanical properties have demonstrated that the strength characteristics of the bars from the studied alloy are higher when the CRE process is implemented (temporary tear resistance is up to 213 MPa), while the plastic ones (relative elongation is up to 33.6%) are higher when implementing the CCRE process. The conclusion has been drawn that the CCRE method of manufacturing modifying bars from the Al-5Ti-1B alloy makes it possible to reduce the energy costs by a factor of 1.5-2 compared to the traditional processing methods; and to obtain an increased level of the plastic properties of the metal as well.

Key words: aluminum alloys, modification, titanium, boron, combined processes, casting, rolling, extrusion, rheological properties, mechanical properties.

Introduction

Nowadays, the metallurgical industry in Russia is experiencing an acute need for bars from Al-Ti-B alloys, the bulk of which is manufactured abroad. These bars are widely used to modify ingots from aluminum alloys in order to improve mechanical properties and to reduce gas porosity [1-4]. The most demanded bars for modifying are those made of the Al-Ti-B alloy which contains 5% titanium and 1% boron.

The mechanism of the modification process is rather complicated and its effect on the structure of pure aluminum and its alloys depends on many parameters that can be relatively divided into two groups [1]. The first group of parameters is determined by the physicochemical properties of refractory modifier particles, as a whole, these properties are expressed by chemical nature, structural, dimensional and adsorption factors. The second group includes the temperature and time mode of melting and casting of alloys, the concentration of the modifier, the cooling rate of the ingot and the particle size of the intermetallic compounds.

The first experiments on grinding grain of aluminum alloys with joint additives of titanium and boron were carried out by A. Kibula and his colleagues from the British Non Ferrous Metals Federation [5]. In this work, in order to obtain the optimum modifying effect, the following concentrations are recommended: 0.01-0.03% Ti and 0.003-0.010% B. The company "Kavekki" recommends to introduce 0.0025-0.0075% Ti and 0.0005 -0.0015% B in pure aluminum, and in the aluminum deformable alloys it's recommended to introduce 0.003-0.015% Ti and 0.0006-0.0003% B. As the size of the ingot increases, the addition alloy must be increased. The ligature must be introduced only into the primary aluminum and added into the melt 15-20 minutes before the start of casting.

When studying the grinding of grain in ingots of aluminum alloys with additives of titanium or titanium and boron, A. Kibul [5] and later M.V. Mal'tsev [6,7] considered the theory of nucleation as the basis of the modifying process. It was established that during crystallization of alloys without titanium additives, subcooling takes place, the temperature could fall to 1-2 degrees Celsius, whereas when 0.002-0.100% Ti is introduced, there is no subcooling. At the same time, a fine-grained structure is obtained along the section of the ingot. All these factors afforded ground for believing that the grain was crushed due to the presence of embryos on which crystallization of the melt started. Such particles can be carbides, borides and aluminides of transition metals having lattice parameters corresponding to those of solid aluminium solution.

Experimental research carried out by the authors of [8-16] have shown that the maximum degree of modification is observed when the ratio of titanium to boron concentration is 5: 1; at greater or less ratios the effect of modifying decreases. Obviously, the modification takes place when titanium aluminide predominates, although borides can be an embryo during aluminum solidification. The main difference between these two types of embryos is that the solidification of aluminum on titanium aluminide occurs without subcooling, whereas for borides some subcooling is quite necessary. It should also be noted that the application of high-speed crystallization-deformation methods provides a high

modifying ability of a bar master alloy of this composition during the process of casting ingots of aluminum alloys [17].

Based on the above mentioned research results, the technologies of combined casting and rolling have been developed abroad and are now applied to produce alloy bars (rods) from Al-Ti-B alloys with different contents of titanium and boron. For their manufacturing casting-rolling machines having high performance and continuous nature of the processing are used. However, the use of sequential profiled rolling in the manufacturing process of deformed semi-finished products from these alloys often leads to cracking because of the occurrence of tensile stresses, and the technology of their manufacturing demands high energy intensity. At the same time, it is known that these alloys are extensively easily extruded, which is associated with the realization in this process of a favorable tension state scheme (all-around uneven pressure). However, the use of high-power horizontal hydraulic presses for the manufacturing of bars from 1.25 to 2.5 MN is characterized by the lack of continuity of the treatment process (cyclicality), as well as by high labor and energy costs.

Avitsur's idea [18] about the use of friction forces for extruding metal was embodied in the processes combining the operations of casting, rolling and extrusion in a single processing cycle [19]. One can identify two possible variants of this process (Fig. 1): combined rolling-extrusion (CRE) of a billet in the solid state formed by the method of continuous casting (Fig. 1, a) and the metal-free treatment of metal in the solid-liquid state (Figure 1, b).

In this case, the press matrix overlaps the closed caliber of the rolls at the outlet from them. By means of this matrix a bar of a certain diameter is formed. The second variant of the process is characterized by simultaneous high-speed crystallization-deformation of metal in rolls and its extrusion through the matrix, thus this method was called the method of combined casting and rolling-pressing (CCRE) [19].

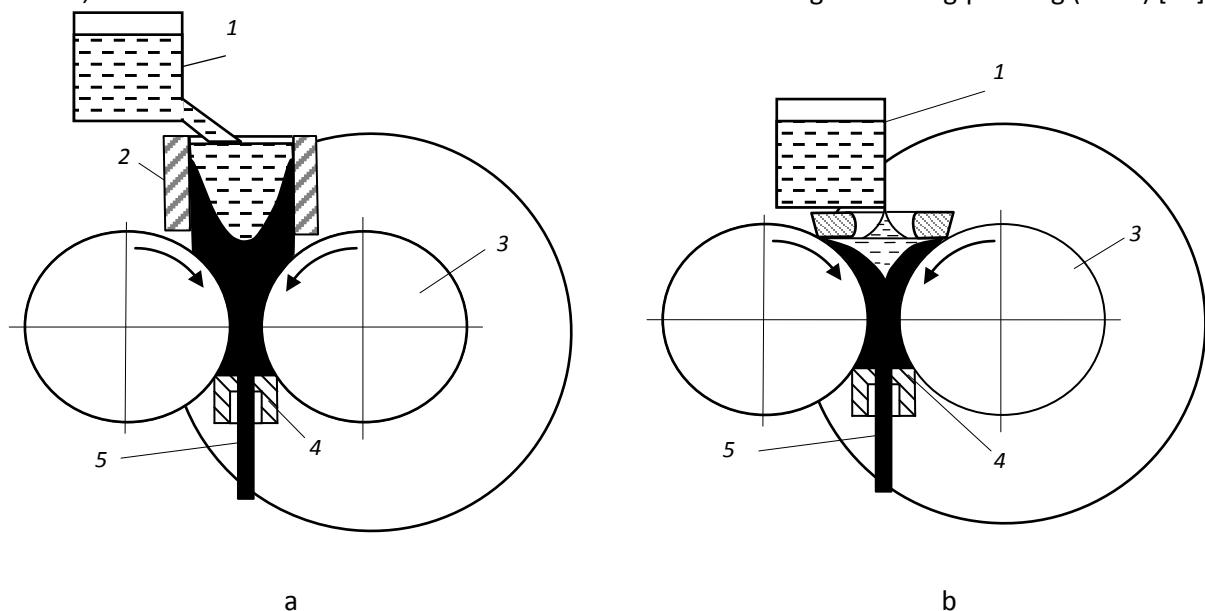

Fig. 1. Variants of the combined metal treatment: *a* - with the crystallization of the billet before rolling; *b*- with the crystallization of the billet in the rolls; 1-holding furnace; 2 – casting mold; 3 - rolls; 4 - matrix; 5 - bar

Methods of research

To implement the above mentioned variants of the combined processing, special laboratory equipment having different roll diameter and productivity have been designed (Fig. 2).

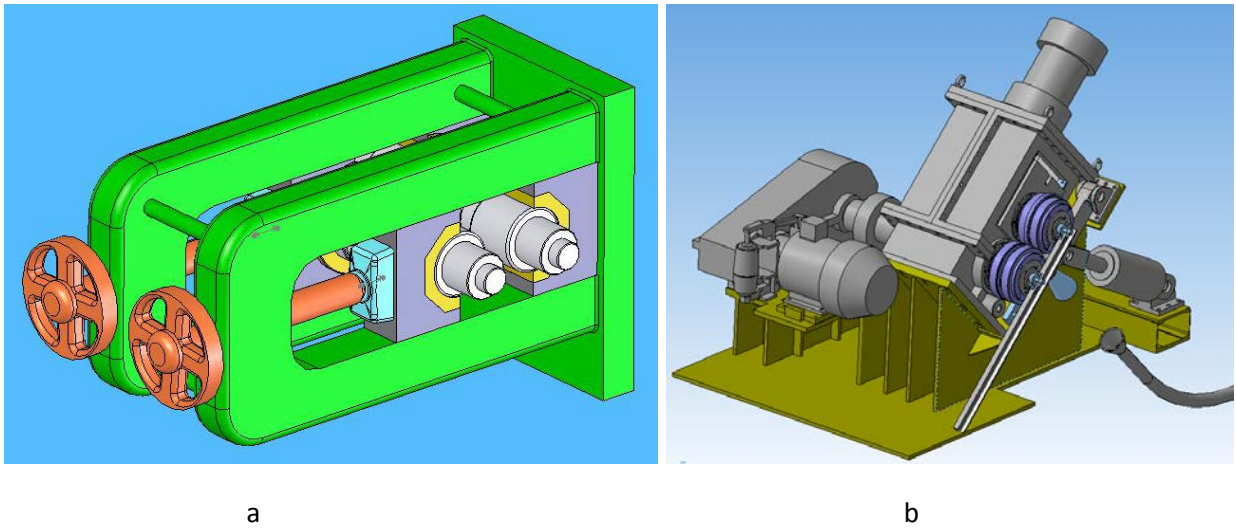

Fig. 2. Models of combined processing machines CRE-200 (a) and CCRE-2,5 (b)

The technical characteristics of the machines CRE-200 (Figure 2, a) and CCRE-2,5 (Figure 2, b) located in the laboratory of Metal Forming Department of the Non-Ferrous Metals and Materials Science School of the Siberian Federal University are presented in Table 1.

Table 1 - Technical characteristics of combined treatment machines plants

Parameters	CRE-200	CCRE -2,5
Initial diameter of the roll, mm	200	480
Length of the roll body, mm	240	250
Diameter of the journal, mm	100	150
Number of revolutions of the roll, rpm	4, 8, 14	1-15
Gear box ratio, unit	40	40
Electric motor power, kW	20	45
Output torque, kNm	10	20
Process pressure of the hydraulic station, kp/ cm ²	100	200
Hydraulic station operation pressure, MPa	10	20
Maximum pressing force, kN	300	300

To analyze the studied process, the data on dimensionless and geometric parameters (Table 2) for the above mentioned combined treatment machines we used.

Table 2 - Data for combined processing calculating.

Value	Name of installation		Dimensionless parameter
	CRE -200	CCRE -2,5	
ledge roll diameter D1, mm	214	462	-
Groove roll diameter D2, mm	164	394	-
Minimum height of caliber h, mm	7	10	-
Average diameter of rolls D0, mm	189	428	$A = \frac{D_0 - h}{h}$
caliber width b, mm	15	22	$\tilde{b} = \frac{b}{h}$
Initial billet height h0, mm	14	20	$\tilde{h}_0 = \frac{h_0}{h}$
Initial billet width b0, mm	14	20	$\tilde{b}_0 = \frac{b_0}{h}$
height of matrix mirror hm, mm	0	25	$\tilde{h}_M = \frac{h_M}{h}$
moulding diameter d, mm	7-9	9-12	$\tilde{h}_1 = \frac{d}{h}$

For the purpose of analyzing metal deformation and energy-force parameters of the combined processing, a mathematical model of rolling-pressing in closed box calibers [19] and a system of equations including the power balance equation and the variational equation of the minimum full power principle were used.

$$(N_{вн} + N_{сп} - N_{ск} - N_{вал}) = 0,$$

Where $N_{вн}$ is power of internal forces; $N_{сп}$ is the shear force; $N_{ск}$ is power friction stresses on the sliding speeds; $N_{вал}$ is power supplied by rolls.

To determine the components of the total power, we used formulas

$$N_{\text{eH}} = \int_V 0,58\sigma_s H dV, N_{\text{cp}} = \int_{F_{\text{cp}}} 0,58\sigma_s |V^+ - V^-| dF, N_{\text{ck}} = - \int_{F_{\text{K}}} \tau_{\text{mp}} v_{\text{ck}} dF, N_{\text{eal}} = \int_{F_{\text{K}}} \tau_{\text{mp}}^* v_{\text{e}} dF,$$

Where H is the shear-strain rate intensity; σ_s - metallic resistance; V^+ , V^- - are the projections of the flow velocity of the metal onto the tangent plane to the surface of discontinuity of the velocities F_{cpj} , respectively, from the inner and outer sides of this surface; N is the number of discontinuity surfaces; τ_{mp} is the frictional stress; τ_{mp}^* is the projection of the total frictional stress on the tangent to the circumference of the roll at any point on the contact surface.

The solution of the variational task made it possible to obtain a numerical array of data on the force acting on the matrix P_{M} and the rolls P_{B} , depending on the dimensionless parameters of the rolling-pressing process and on the formula for calculating the unknown quantities that were used while calculating the energy-force parameters:

-For the force acting on the matrix

$$P_{\text{M}} = \frac{0,12\sigma_s(A-11,5)}{\sqrt{3}} [2\ln\mu(\tilde{b}+1)(L_1+L_2)h - \frac{\tilde{b}}{(A+1)}(L_1^2+L_2^2) + \frac{\ln\mu}{2h(A+1)}(L_1^3+L_2^3) - \frac{\tilde{b}h}{12(2hA+2h)^3}(L_1^4+L_2^4) + \frac{\ln\mu}{30(2hA+2h)^3}(L_1^5+L_2^5)];$$

-For the force acting on the rolls

$$P_{\text{B}} = (1,7 - 0,38A)\sigma_s \frac{4\tilde{b}h}{\sqrt{3}} \left[\left(\frac{h}{12h(A+1)} - 1 \right) (L_1 \ln(2h^2(A+1) + L_1^2) + L_2 \ln(2h^2A + 2h^2 + L_2^2)) - (L_1 + L_2) \left(\frac{h}{12h(A+1)} - 1 \right) \ln(2h^2(A+1)) + \frac{3\ln\mu}{2\tilde{b}h} (L_1^2 + L_2^2) - \frac{(L_1^3 + L_2^3)}{12(2hA+2h)^2} + \frac{2\tilde{b}h}{\sqrt{3}} + \frac{\ln\mu}{\tilde{b}h} \left(\frac{\tilde{b}h\sqrt{2h(A+1)}}{\sqrt{h}} - \sqrt{2h^2(A+1)} \right) \times \left(L_1 \arctan \frac{L_1}{\sqrt{2h^2(A+1)}} + L_2 \arctan \frac{L_2}{\sqrt{2h^2(A+1)}} \right) \right],$$

Where L1 is the length of the gripping zone during rolling, L2 - the length of pressing off area (Fig. 1b), μ - reduction at extrusion.

By means of the formulas obtained, calculations of energy-force parameters for the production of bars of various diameters with the use of existing combined processing machines were made. The rheological characteristics of the studied alloy (Fig. 3) which had been earlier obtained[20], were used for calculations. The calculation data are given in Table 3, where the numerator is calculated (Pv.ras., Rm.ras.) ,and the denominator presents the experimental (Pv.ex., Pm.ex.) values of the forces acting on the rolls and the matrix.

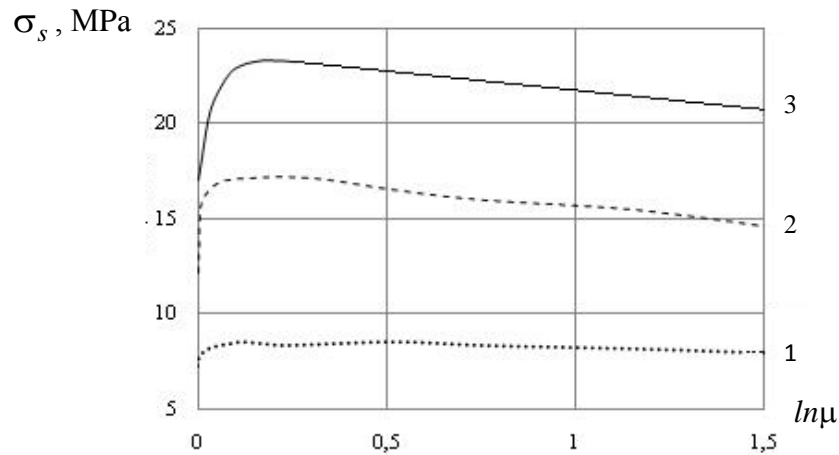

Fig. 3. Rheological characteristics of the Al-5Ti-1B alloy at 550 degrees Celsius: 1 - $\xi = 0.034 \text{ s}^{-1}$; 2 - $\xi = 0.304 \text{ s}^{-1}$; 3 - $\xi = 3.04 \text{ s}^{-1}$

The preheating temperature of billets before CRE (see Table 3) was 550 and 575 ° C, and the melt temperature before CCRE was 750 and 780 ° C.

The strain rate for the parameters of the combined processing (Table 2) was calculated by means of the following formula:

$$\xi = \frac{\pi n \sqrt{0,5 D_0 (h_0 - h)}}{30 h_0}$$

Where n is the roll speed, rpm (Table 1).

Data presented in Table 3. allow us to draw the following conclusions:

- the stronger the forces act on the rolls and the matrix – the higher is the reduction ratio μ when the metal is extruded through the matrix, since in this case the degree of strain in pressing increases;
- as the heating temperature of the billet (or melt temperature) increases, the forces decrease, since the metallic resistance decreases;
- as strain rate increases, the energy-force parameters of the combined rolling-pressing process are reduced owing to strain heating and reduced heat transfer to the tool;
- for the CCRE process, an inverse dependence of the forces on the rate of strain is observed, which is apparently due to the peculiarities of the crystallization of the metal in the rolls, which do not have time to heat up and the metal contacts the cold rollers, instantly solidifying on them;
- the results of calculations by the above mentioned formulas give a satisfactory convergence of the calculated and experimental data, so we can recommend them for predicting the energy-force parameters of the combined processing.

Table 3 - Results of energy-force parameters calculations for combined processing of Al5Ti1B alloy in comparison with experimental data

Temperature	Strain rate	Force kN
-------------	-------------	----------

T, °C	ξ, c^{-1}	Pv.ras./ Pv.ex.			Rm.ras./ Pm.ex.		
		$\mu=11,5$	$\mu=8,6$	$\mu=3,5$	$\mu=11,5$	$\mu=8,6$	$\mu=3,5$
CRE-200							
550	0,77	<u>181,6</u>	<u>148,8</u>	<u>141,8</u>	<u>115,7</u>	<u>96,4</u>	<u>89,0</u>
		179,4	146,4	140,0	110,3	93,0	86,4
550	2,69	<u>131,5</u>	<u>105,2</u>	<u>93,9</u>	<u>85,0</u>	<u>68,0</u>	<u>60,7</u>
		129,8	102,0	91,5	83,0	66,4	59,4
575	0,77	<u>112,3</u>	<u>80,2</u>	<u>72,4</u>	<u>110,0</u>	<u>92,9</u>	<u>78,7</u>
		108,6	77,6	70,9	106,3	89,6	71,9
575	2,69	<u>63,8</u>	<u>58,4</u>	<u>47,1</u>	<u>81,1</u>	<u>60,3</u>	<u>33,8</u>
		61,4	55,4	44,8	79,7	56,4	32,5
CCRE-2,5							
		$\mu=16,8$	$\mu=8,6$	$\mu=5,2$	$\mu=16,8$	$\mu=8,6$	$\mu=5,2$
750	0,74	<u>87,1</u>	<u>72,6</u>	<u>64,0</u>	<u>82,3</u>	<u>65,8</u>	<u>58,8</u>
		85,0	71,1	63,2	75,2	60,3	53,1
750	1,49	<u>125,2</u>	<u>106,8</u>	<u>98,6</u>	<u>100,1</u>	<u>89,2</u>	<u>86,4</u>
		120,2	105,1	94,5	94,5	87,1	84,2
780	0,74	<u>60,2</u>	<u>56,3</u>	<u>52,2</u>	<u>55,2</u>	<u>53,3</u>	<u>50,0</u>
		58,0	54,1	50,2	54,1	52,1	49,2
780	1,49	<u>105,5</u>	<u>90,3</u>	<u>88,8</u>	<u>93,7</u>	<u>84,4</u>	<u>77,7</u>
		98,1	89,3	84,2	91,5	83,7	76,5

The metallographic analysis was carried out on rod samples 9 mm in diameter (Figure 4) after grinding, polishing, etching; and the resulting microstructure was examined with the use of the microscope OBSERVER.D1 made by Zeiss. The microstructure of the samples was imaged and stored in the computer memory by means of the program AxioVision. The microstructure was studied at hundredfold magnification.

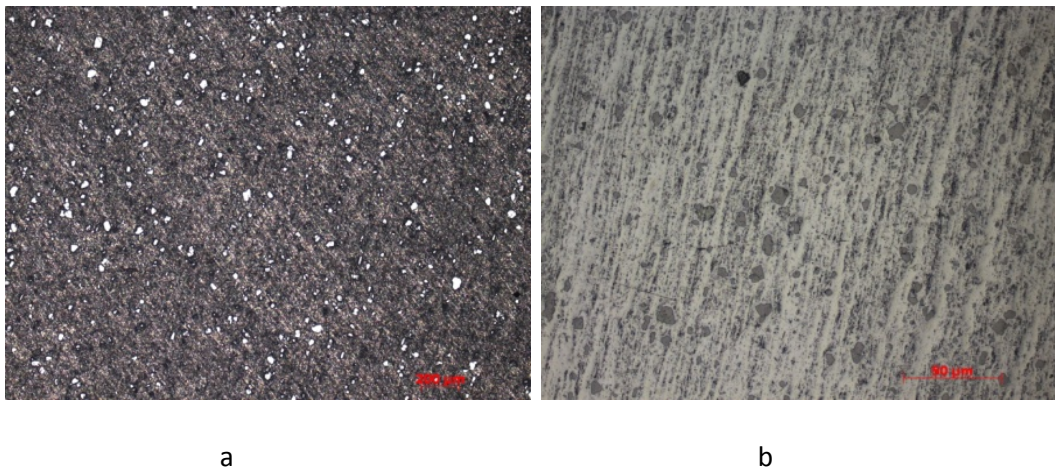

Fig. 4. Microstructure of rods after CRE (a) and after CREP (b), x 100

The inhomogeneity of the modifying additives distribution is clearly visible on bars of 9 mm diameter, which were obtained by the CRE method (Fig. 4, a), and small, fairly uniformly distributed inclusions are visible on the surface, which enlarge from the edge of the sample to its center. When the strain rate increases, the inclusions are equalized in magnitude and uniformly distributed over the cross section of the samples. The metallographic analysis of the bars obtained by the CCRE method (Figure 4, b)

demonstrated that this processing rate gives an optimal location and the value of the intermetallic phases, while the particles are evenly distributed over the cross-section and are dispersed.

The results of testing the mechanical properties of rods manufactured with the use of the combined processing machines (21) showed that the values of the time resistance to a tear in a given temperature-velocity range when the drawing is varied from 5.2 to 16.8 are 135-213 MPa for the CRE process and 111 -167 MPa for the CCRE process. In this case, the values of the relative elongation of the metal are 2.1-19.6% for the CRE process and 8.9-33.6% for the CCRE process, respectively. Thus, the strength characteristics of bars are higher during the implementation of the REP process, and the plastic characteristics are higher when implementing the CCRE process.

Conclusion

Taking into account the results of previous experimental and theoretical research, the obtained data made it possible to present a technical plan for the design and start-up of the pilot-plant equipment CCRE 4 at the Irkutsk Aluminum Smelter Plant. In general, the carried out research have shown that the production of modifying bars from the Al-5Ti-1B alloy by the combined processing methods makes it possible to manufacture products with minimal energy-force costs, so the force parameters are 1.5-2 times less compared to traditional processing methods. However, the required level of properties, in particular plastic characteristics, can be obtained by selecting for processing the combined casting and rolling-pressing method.

References

1. Napalkov V.I., Makhov S.V. Alloying and Modification of Aluminum and Magnesium. - Moscow: Moscow Institute of Steel and Alloys, 2002. - 376 p.
2. Bondarev B.I., Napalkov V.I., Tararyshkin V.I. Modification of Deformable Aluminum Alloys. - M.: Metallurgy, 1979. - 224 p.
3. Beletsky V.M, Krivov G.A. Aluminum alloys. Composition, Properties, Technology, Application. Reference Manual. Under the general editorship of Acad. I.N. Friedlyander. - Kiev: COMINTEH, 2005. - 365 p.
4. Elagin V. I. Impurity Doping of Deformable Aluminum Alloys with Transition Metals. - M.: Metallurgy, 1975. - 248 p.
5. Cibula A. The Grain Refinement of Aluminium Alloys Castings by addition of Titanium and Boron.//J. I

Bibliographic list

6. Maltsev M.V. Modern methods of improving the structure and physic-mechanical properties of non-ferrous metal s. - M.: VINITI, 1957. - 28 p.
7. Maltsev M.V. Modification of the Structure of Metals and Alloys. - M.: Metallurgy, 1964. - 213s.
8. Makhov S.V. Scientific and Technological Justification for the Development and Application of Modifying Ligatures // Metallurgy of Mechanical Engineering, 2012.- No. 1.- P.10-15.
9. Marcantonio J., Mondolfo L. Grain Refinement in Aluminum Alloyed with Titanium and Boron // Metallurg. Trans. - 1971, Vol. 2, No. 2. - P. 465-471.
10. Wang X., Song J., Vian W., Ma H., Han Q. The Interface of TiB₂ and Al₃Ti in Molten Aluminum. - Metallurgical and Materials Transactions B. 2016. Vol. 47, Issue 6, pp. 3285-3290.
11. Wei Z., Gao X., Feng Z. Application of Al-Ti-B Wire in the New High Strength Wear Resistant Piston Materials. Tezhong Zhuzao Ji Youse Hejin / Special Casting and Non Ferrous Alloys. 36 (8), pp. 874-876.
12. Xu-Guang An, Y. Liu, Jin-Wen Ye, Lin-Zhi Wang, Peng-Yue Wang. Grain Refining Efficiency of SHS Al-Ti-B-C Master Alloy for Pure Aluminum and Its Effect on Mechanical Properties. Acta Metallurgica Sinica. 2016. Vol. 29, Issue 8, pp. 742-747.
13. Rakhmonov, J., Timelli, G., Bonollo, F., The Influence of AlTi₅B₁ Grain Refinement and the Cooling Rate on the Formation of Behaviour of Fe-rich Compounds in Secondary AlSi₈Cu₃ alloys. Metallurgia Italiana. 2016. 108 (6), pp. 109-112.
14. Wang X., Han Q. Grain Refinement Mechanism of Aluminum by Al-Ti-B Master Alloys, in Light Metals 2016 (ed E. Williams), John Wiley & Sons, Inc., Hoboken, NJ, USA. 2016.
15. Zhang Z., Wang J., Xia X., Zhao W., Liao B., Hur B. The Microstructure and Compressive Properties of Aluminum Alloy (A356) Foams with Different Al-Ti-B additions. Medziagotyra. 2016. Vol. 22, Issue 3, 2016, pp. 337-342.
16. Wang X., Han Q. Grain Refinement Mechanism of Aluminum by Al-Ti-B Master Alloys. TMS Light Metals, 2016. pp. 189-193.
- 17 a multi-authored monograph / S.B. Sidelnikov, E.S. Lopatina, N.N. Dovzhenko [and others]. Peculiarities of the Structure Formation and Properties of Metal at High-Speed Crystallization-Deformation and Modification of Aluminum Alloys. Krasnoyarsk: Sib. Federal University, 2015.- 180 s.
18. Avitzur B. Combining Extrusion and Rolling / B. Avitzur // Wire journal. - 1975. - P. 73-80.
19. Sidelnikov SB Combined and Mixed Methods of Non Ferrous Metals and Alloys Processing: monograph / S.B. Sidelnikov, N.N. Dovzhenko, N.N. Zagirov - M.: MAX Press. - 2005.- 344 p.
20. N.A. Grischenko, S.B. Sidelnikov, I.Yu. Gubanov [and others]. Mechanical Properties of Aluminum Alloys. Krasnoyarsk: Sib. Feder. University, 2012.- 196 pp.
21. S. B. Sidelnikov, D.S. Voroshilov, A.A. Startsev [and others]. Analysis of the Combined Processing Parameters for the Production of Grain Refiner Rods from the Alloys of the Al-Ti-B System. S. B. Sidelnikov, D.S. Voroshilov, A.A. Startsev [and others]. Journal of Siberian Federal University. Technics and technology. 2015, No. 5 (2015 8), p. 646-654.