



Aalborg Universitet

AALBORG UNIVERSITY
DENMARK

Analysis of Enhancement in Available Power Transfer Capacity by STATCOM Integrated SMES by Numerical Simulation Studies

Saraswathi, Ananthavel; Sanjeevikumar, Padmanaban; Shanmugham, Sutha; Blaabjerg, Frede; Ertas, Ahmet H.; Fedák, Viliam

Published in:
Engineering Science and Technology, an International Journal

DOI (link to publication from Publisher):
[10.1016/j.jestch.2015.10.002](https://doi.org/10.1016/j.jestch.2015.10.002)

Creative Commons License
CC BY-NC-ND 4.0

Publication date:
2016

Document Version
Publisher's PDF, also known as Version of record

[Link to publication from Aalborg University](#)

Citation for published version (APA):
Saraswathi, A., Sanjeevikumar, P., Shanmugham, S., Blaabjerg, F., Ertas, A. H., & Fedák, V. (2016). Analysis of Enhancement in Available Power Transfer Capacity by STATCOM Integrated SMES by Numerical Simulation Studies. *Engineering Science and Technology, an International Journal*, 19(2), 671-675.
<https://doi.org/10.1016/j.jestch.2015.10.002>

General rights

Copyright and moral rights for the publications made accessible in the public portal are retained by the authors and/or other copyright owners and it is a condition of accessing publications that users recognise and abide by the legal requirements associated with these rights.

- Users may download and print one copy of any publication from the public portal for the purpose of private study or research.
- You may not further distribute the material or use it for any profit-making activity or commercial gain
- You may freely distribute the URL identifying the publication in the public portal -

Take down policy

If you believe that this document breaches copyright please contact us at vbn@aub.aau.dk providing details, and we will remove access to the work immediately and investigate your claim.



Full Length Article

Analysis of enhancement in available power transfer capacity by STATCOM integrated SMES by numerical simulation studies



Saraswathi Ananthavel ^a, Sanjeevikumar Padmanaban ^{b,*}, Sutha Shanmugham ^c,
Frede Blaabjerg ^d, Ahmet H. Ertas ^e, Viliam Fedak ^f

^a Department of Electrical & Electronics Engineering, University College of Engineering Villupuram, Anna University, Chennai, Tamilnadu, India

^b Research and Development, Ohm Technologies, Chennai, Tamilnadu, India

^c Department of Electrical & Electronics Engineering, University College of Engineering Dindigul, Anna University, Chennai, Tamilnadu, India

^d Department of Energy Technology, Aalborg University, Pontoppidanstraede 101, 9220 Aalborg, Denmark

^e Department of Biomedical Engineering, Engineering Faculty, Karabuk University, Karabuk, Turkey

^f Department of Electrical Engineering & Mechatronics, Technical University of Kosice, Slovakia

ARTICLE INFO

Article history:

Received 4 July 2015

Received in revised form

1 October 2015

Accepted 6 October 2015

Available online 10 November 2015

Keywords:

Available transfer capability (ATC)

Flexible ac transmission system

Reactive power compensation

Superconducting magnetic energy storage

Static synchronous compensator

ABSTRACT

Power system researches are mainly focused in enhancing the available power capacities of the existing transmission lines. But still, no prominent solutions have been made due to several factors that affect the transmission lines which include the length, aging of the cables and losses on generation, transmission and distribution etc. This paper exploited the integration of static synchronous compensator (STATCOM) and superconducting magnetic energy storage (SMES) which is then connected to existing power transmission line for enhancing the available power transfer capacity (ATC). STATCOM is power electronic voltage source converter (VSC) which is connected to the transmission system for shunt reactive power and harmonics compensation. SMES is a renowned clean energy storage technology. Feasibility of the proposed power system can control the real as well as reactive power flow independently between the transmission lines and STATCOM-(SMES) units. Complete proposed power system is implemented in numerical simulation software (Matlab/Simulink) and its performance is validated based on obtained investigation results.

© 2016, Karabuk University. Publishing services by Elsevier B.V.

1. Introduction

Today's demands in power sector lies on proper planning which improve the Available Power Transfer Capacity (ATC) of the existing transmission lines and avoid drastic blackouts. In such congestion management, the Flexible AC Transmission System (FACTS) controllers play a vital role. Among the FACTS controllers, STATCOM (static compensator) is the most prominent choice for reactive power flow and harmonic control in the transmission grid system [1–3]. It consists of a three-phase voltage source converter (VSC) connected in shunt with the transmission line through a step-up transformer and a dc link capacitor as shown in Fig. 1. Shunt connected VSC (STATCOM) inject current vector into the transmission line in such a way to maintain the voltage across the dc capacitor which is always constant. It means that the continuous reactive power compensation had been done with limited real power compensation [2–4].

The integration of an electrical energy storage system and the power system security improved by storing excess energy during the off-peak load periods [5]. Even though the super conducting phenomena was developed in 1911, the application in electric energy storage system was proven by adequate research articles from 1970. Energy storage systems such as Pumped Storage Hydroelectric System (PSHS), Battery Energy Storage System (BESS) and Superconducting Magnetic Energy Storage (SMES) are available. Among these topologies the SMES finds attraction due to its fast response and highly efficient performances (95%) [6]. The main limiting factor of SMES is its operating temperature, which decides the cost and operating conditions of the superconductor. The SMES unit may add a tremendous amount of spinning reserve capacity with low cost when it is connected to the power system. Under the circumstance, when SMES is disconnected by the breaker switch, still it is possible to provide continuous rated capacity of VAR to the power system by the STATCOM operation alone [7–11] with increased security level. Nowadays due to the availability of Low Temperature Superconductors, research is moving towards the development of High Temperature Superconductor (HTS). The SMES unit adds a tremendous amount of spinning reserve energy flow capacity to the grid through VSCs at low cost. But the main limiting factor of SMES

* Corresponding author. Tel.: +91 98431 08228.

E-mail addresses: sanjeevi_12@yahoo.co.in; sanjeevipowerelectronics@gmail.com (S. Padmanaban).

Peer review under responsibility of Karabuk University.

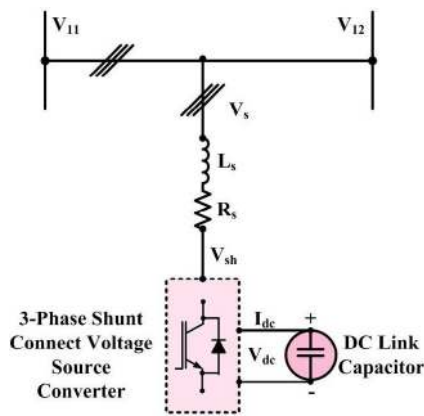

Fig. 1. Schematic circuit of static compensator (STATCOM) showing shunt compensation voltage source converter (VSC) integrated with transmission line.

is its operating temperature, which decides the cost and operating conditions by the superconductors [7,9,10].

Considering the above facts, this research work develops ATC system based on integration of STATCOM and SMES to increase the power transfer capacity for the grid security and controlled operation shown in Fig. 2. The paper work is organized as follows: the basic concepts and operating principle of STATCOM with SMES integration are explained in section 2. Real power control compensation and enhancement of power system security are developed using numerical simulation software (Matlab/Simulink) which is given in section 3. Set of numerical simulation results are provided and explained in section 3 to validate the proposal of ATC. Finally, the conclusion of this paper work is presented in section 4.

2. Principle operation of STATCOM and SMES integration

The block diagram of STATCOM with SMES unit is shown in Fig. 2. STATCOM is controlled by standard synchronous reference controller, where the reference signal is obtained by comparing the *d* and *q* axis voltages, which are derived through the PI controller process on the *d* and *q* axis component of the line currents [12–14]. The required current vector is determined by comparing *V_{dc}* (dc link voltage) and *V_s* (system source voltage) with *V_{dcref}* (dc reference voltage) and *V_{sref}* (system reference voltage at the point of

connection) respectively. The real power flow which is transferred from the sending end to receiving end (assuming *V_s* = *V_r*), is given by the equation below [12,15,16]:

$$P_{s1} = \frac{V^2}{X_L} \sin(\delta) \tag{1}$$

where,

- V_s* is the magnitude of sending end voltage,
- V_r* is the magnitude of receiving end voltage,
- V_c* is the compensation voltage of the converter,
- δ is the phase difference between the sending and receiving end voltages.

If the phase angle between the sending end and receiving end are $\pm\delta/2$, then there is no absorption or generation of active power but merely reactive power is compensated. For instance, if the phase difference is not equal to $\delta/2$, for small interval of time the STATCOM compensates the real power flow. Now, the power transferred to the receiving end is given by the equation below [12,15,16]:

$$P_{s2} = \frac{2V^2}{X_L} \sin\left(\frac{\delta}{2}\right) \tag{2}$$

From Eqs. 1 and 2 with STATCOM, the real power transferred from sending to receiving end is improved to a great extent, since $2\sin\left(\frac{\delta}{2}\right)$ is always greater than $\sin(\delta)$ and where δ range between 0 and 2π . Therefore, the maximum real power and reactive power at receiving end are given by:

$$P_{r1} = \frac{V^2}{X_L} \sin(\delta) \tag{3}$$

$$Q_{r1} = \frac{V_r V_s}{X_L} \cos n(\delta) - \frac{V_r^2}{X} \tag{4}$$

Suppose, when the real and reactive power is constant, then power flow is the function of *V*, *X* and power angle alone, which is the phase difference between sending end and receiving end voltages. Meanwhile, if the sending end voltages and receiving end voltages are equal, then the power flow control is governed only by the δ phase angle. To ensure good voltage profile with stability, reactive power should be compensated i.e.:

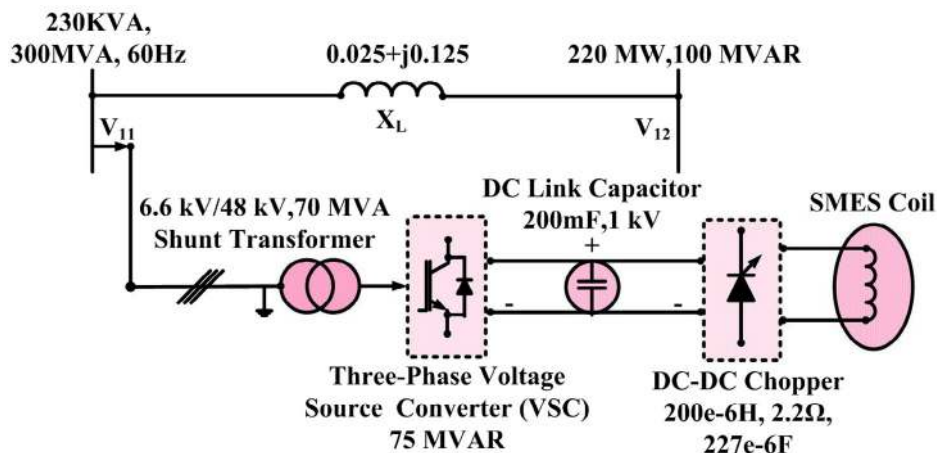

Fig. 2. Schematic circuit of proposed power system with available power transfer capacity enhancement by integrating STATCOM and SMES.

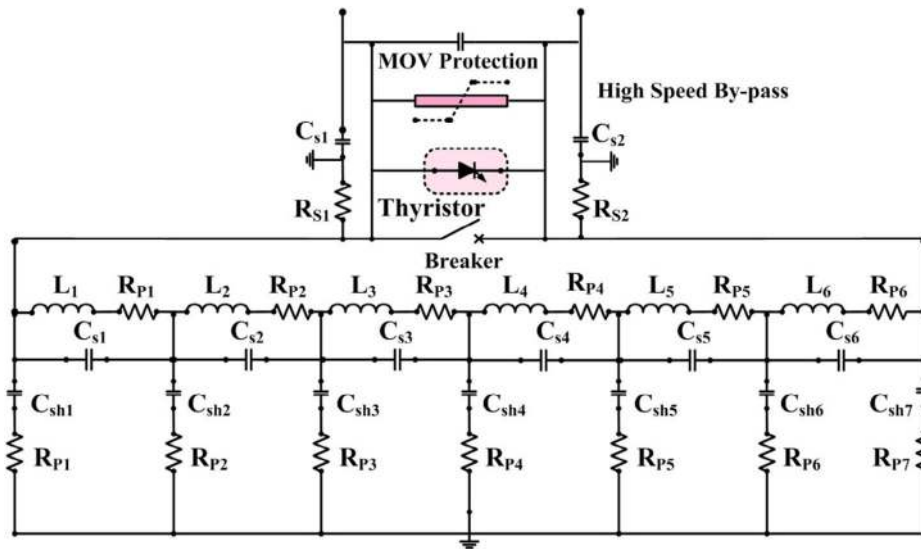

Fig. 3. Schematic circuit of superconducting magnetic energy storage (SMES) with protection units.

$$S = P + jQ \tag{5}$$

where S , P and Q are complex, real, and reactive powers.

The location of STATCOM is an important criterion which had proven that the midpoint in the transmission line is the optimal solution and the same consideration taken in this work [13,14]. When the voltage at the point of connection is more than STATCOM voltage, then the current will flow from the sending end to VSC i.e. acting as inductor to absorb the reactive power. Similarly, when the STATCOM voltage is higher than sending end, then the current flows from VSC to the system i.e. acting as capacitor for delivering reactive power to the system. This action can be easily controlled by modulating the gate pulse of the VSC, a standard SPWM modulation technique is adapted in this investigation. In Fig. 2 by applying Kirchhoff's voltage law for the loop, the complete mathematical model of STATCOM is obtained as given below [15]:

$$\frac{d}{dt} \begin{bmatrix} i_q \\ i_d \\ V_{dc} \end{bmatrix} = \begin{bmatrix} -\frac{R_s}{L_s} & -\omega & 0 \\ \omega & -\frac{R_s}{L_s} & -\frac{m}{L_s} \\ 0 & \frac{m}{c} & 0 \end{bmatrix} \begin{bmatrix} i_{cq} \\ i_{cd} \\ V_{dc} \end{bmatrix} + \frac{V_s}{L_s} \begin{bmatrix} -\sin\alpha \\ \cos\alpha \\ 0 \end{bmatrix} \tag{6}$$

The design of superconductor is complex and some important points need to be considered for a stable, reliable operation and economic design of coil, such as:

- (i) Configuration,
- (ii) Energy capacity,
- (iii) Structure,
- (iv) Temperature and
- (v) Energy to mass ratio.

Network consists of high speed bypass switches which serves for below conditions:

- (i) When the coil is on standby, it is used to reduce energy losses,
- (ii) If the utility tie is lost, it is used to by-pass dc coil current,
- (iii) If the cooling is lost, it is used to protect the coil [7,10,11].

For instant, to store/release required amount of electric energy in magnetic field more segments are designed, i.e. for high power rating the superconductors are configured in multi-segments coil given in Fig. 3. When the breaker switch is closed, the SMES unit is temporarily disconnected from the system. When the breaker switch is opened the current flows into the multi-segment coil and the electrical energy is stored through the dc-dc chopper from the dc link. This energy can be retrieved by controlling the average voltage across the coil which in turn is controlled by the duty cycle of the chopper. Therefore, the two quadrant dc-dc chopper acts as an interface between SMES and dc link which is actually shown in Fig. 2. If the duty cycle is >0.5, the average voltage across the superconductor will increase and charging of coil will start, and power will flow from the power system network to SMES. On the other hand if the duty cycle is <0.5, the average voltage across the

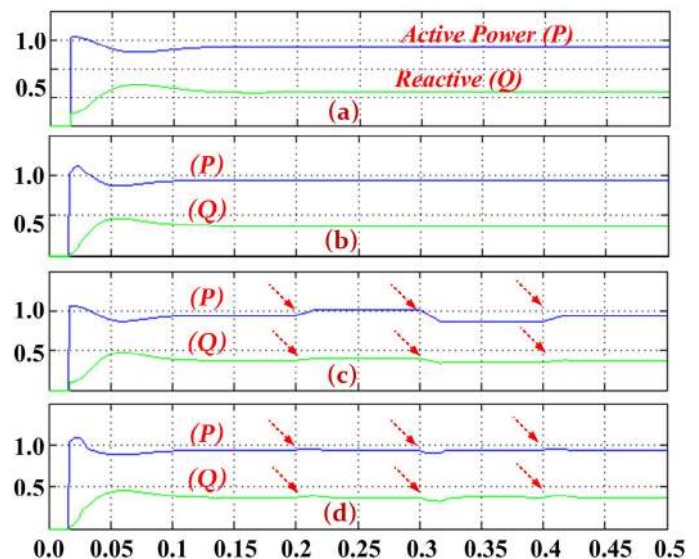

Fig. 4. Simulation results describe the P-Q (active-reactive power) setting under designed test conditions. Voltage control mode of STATCOM (a) without SMES, (b) with SMES. Voltage fluctuation in the supply side (c) with STATCOM, (d) with STATCOM-SMES.

superconductor will decrease and power will flow from SMES to power system network. Hence, by controlling dc current through the coil, it is possible to absorb/inject reactive power from/to the utility grid, i.e. average voltage across the superconductor which is actually decided by the duty cycle of the chopper.

3. Numerical simulation tests verification

Complete model of the proposed ATC based STATCOM–SMES is numerically implemented in Matlab/Simulink software for a standard test power system [16] which is shown in Fig. 2 with sampling period of μ and investigated under different designed conditions. Fig. 4(a) and (b) shows the P–Q (active–reactive power) settings for the first investigation test at sending end terminal (generator side). This test was performed to understand the behavior of the ATC, if the STATCOM integrated with (case one) and without SMES (case two) to the power system circuit, where STATCOM works as a voltage control mode. It is observed that the voltage regulation is perfect in the first case (Fig. 4a) than the second case (Fig. 4b), this is due to effect of charging the super conducting coil by the STATCOM current. But the important factor to be noted in second case is that the reactive power setting Q was much compensated when compared to first case. It is clearly confirmed in Fig. 4(b) that this compensation is used for charging the SMES from the power system through STATCOM.

Second investigation test was performed to understand the behavior of the ATC if there is voltage fluctuation at the sending end (generator side) when STATCOM integrated with (case one) and without SMES (case two) to the power system circuit. Correspondingly, Fig. 4(c) and (d) shows the P–Q (active–reactive power) settings at sending end terminal (generator side). For this purpose generator was programmed for variable three-phase voltage source 1, 0.9, 1, 1.01 p.u. at 0, 0.2, 0.3, 0.4 sec respectively. In case one, the STATCOM is ineffective, since active power is not controlled as expected with system voltage fluctuations. That is the VSC absorbs the reactive power (almost constant) which can be confirmed in Fig. 4(c) irrespective of losing active power. But in case two, STATCOM proves the effectiveness when SMES is integrated to it which is shown in Fig. 4(b). In case of system voltage fluctuations, the STATCOM–SMES maintain the active power almost constant to power system. Whereas SMES charges (absorbs reactive power) and enhance the

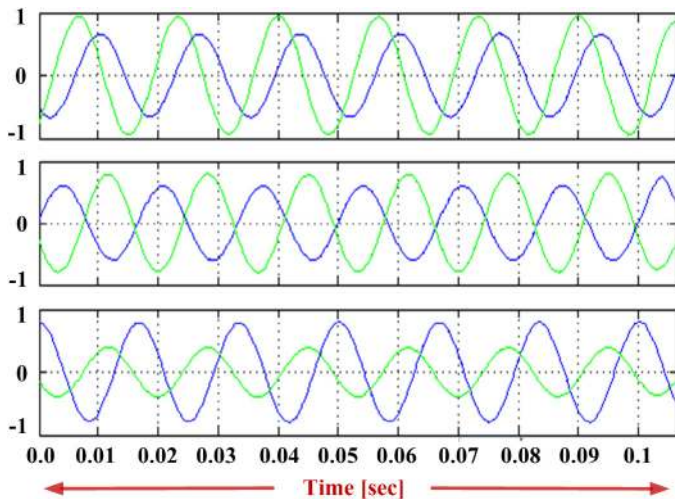

Fig. 5. Transmission line current and voltage at different POC. **Top:** sending end, **Middle:** middle of the transmission line, **Bottom:** receiving end. [X-axis voltage (blue) Volts, Current (green) Amps].

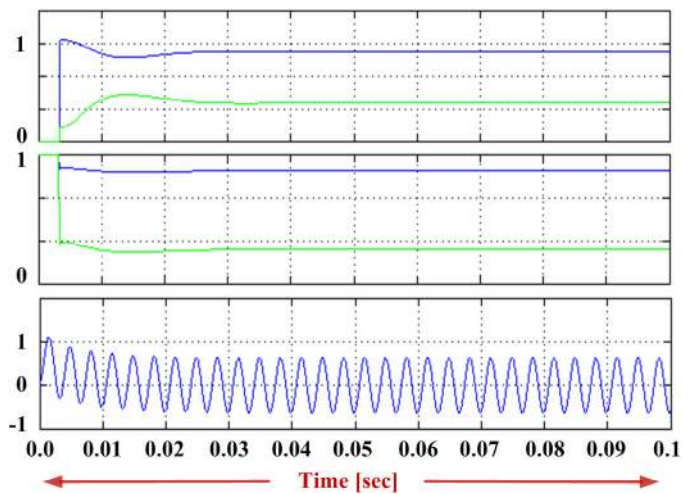

Fig. 6. STATCOM without SMES in voltage control mode. **Top:** P–Q settings at bus 3, **Middle:** voltage at bus 1 and 3, **Bottom:** STATCOM current (X-axis: Current in Amp).

active power (reactive injecting) to power system, hence ATC is guaranteed.

Further, to show the insight technical verifications about the proposed power system, the following investigation results are presented. The point of connection of STATCOM to the system is the vital point. It is found that the middle point is the optimal location in terms of observing the line current and voltage variation at the sending end, middle point and receiving end of the transmission line which are shown in Fig. 5.

In Figs. 6 and 7 the real power, reactive power, voltage at bus 1 & 3 and STATCOM current are shown in two different cases which are STATCOM with and without SMES unit. It is clear that comparatively the voltage regulation is perfect in the first case than the second case with the continuous STATCOM current, which is due to the charging current of the super conducting coil. But this will increase the dynamic performance of the system. To verify that, the variable voltage is set in the programmable three-phase voltage source like 1, 0.9, 1.01, 1 p.u at 0, 0.2, 0.3, 0.4 sec respectively.

Initially the STATCOM is ineffective, and when the system voltage is reduced to 0.9 p.u at $t = 0.2$ sec, the converter absorbs the reactive power. At $t = 0.3$ sec, the supply voltage is increased to 1.01 p.u. Now, the converter delivers the required excess reactive power and

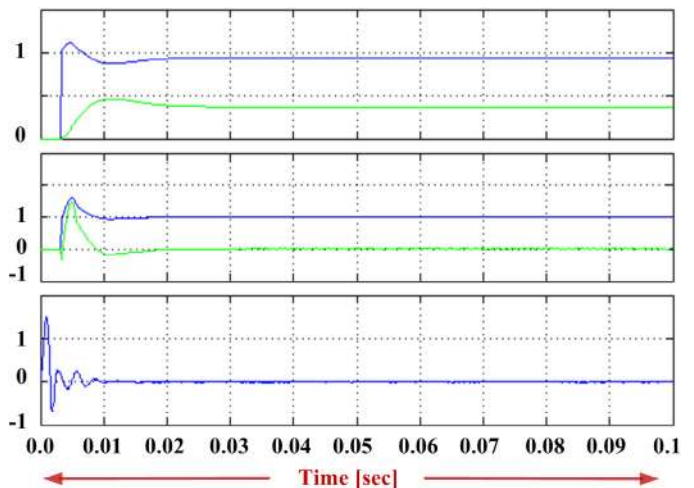

Fig. 7. STATCOM with SMES in voltage control mode. **Top:** P–Q settings at bus 3, **Middle:** voltage at bus 1 and 3, **Bottom:** STATCOM current (X-axis: Current in Amp).

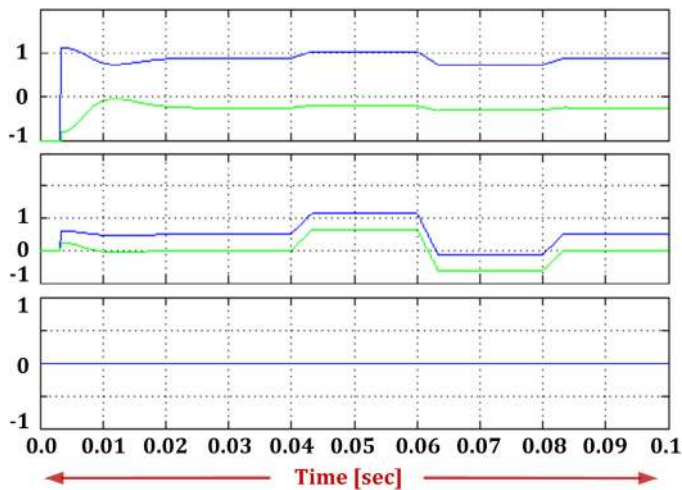

Fig. 8. Voltage fluctuation in the supply side without STATCOM. **Top:** P-Q settings at bus 3, **Middle:** voltage at bus 1 and 3, **Bottom:** STATCOM current (X-axis: Current in Amp).

maintains the real power constant in Q control mode as shown in Figs. 8 and 9.

Also to examine the transient performance of the system, a three-phase fault is introduced at $t = 0.2$ sec and it is cleared at $t = 0.3$ sec in both cases i.e STATCOM with and without SMES unit and its corresponding results are shown in Fig. 10. In STATCOM without SMES unit, the charging current is almost nil but the response is sluggish, that is after clearing the fault, and it requires few cycles to come up to steady state. Similarly in system with STATCOM and SMES continuous charging current is drawn from the line, but during fault condition its response is more rapid.

Finally, by the complete numerical investigation results it could be concluded that Available Power Transfer Capacity (ATC) is enhanced and guaranteed when STATCOM is integrated with SMES.

4. Conclusion

This research paper investigated and proposed ATC (available power capacity) enhancement by exploiting the inherent combi-

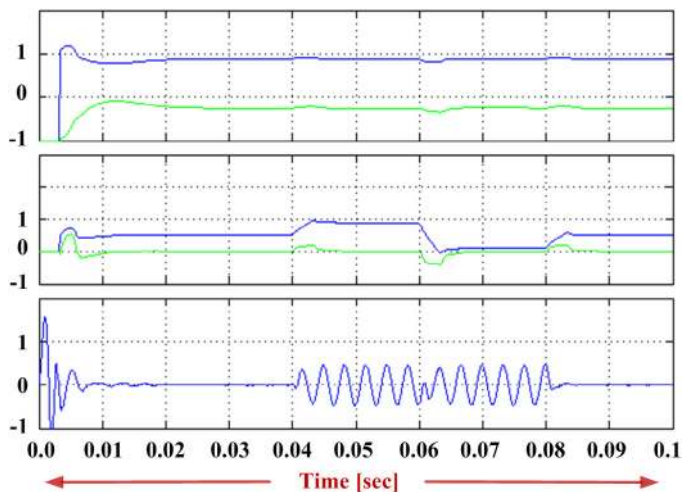

Fig. 9. Voltage Fluctuation in the supply side with STATCOM-SMES. **Top:** P-Q settings at bus 3, **Middle:** voltage at bus 1 and 3, **Bottom:** STATCOM current (X-axis: Current in Amp).

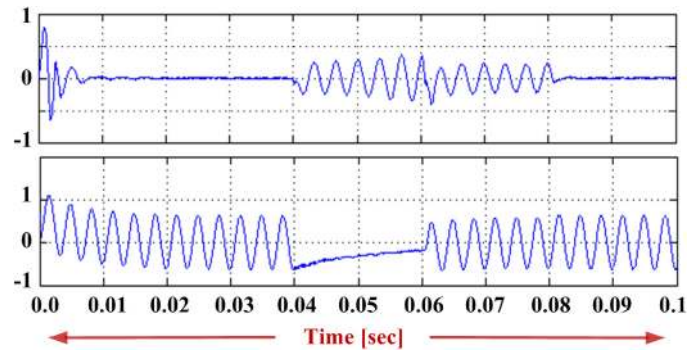

Fig. 10. Response of system under three phase fault condition. P-Q settings at bus 3, **Middle:** voltage at bus 1 and 3, **Bottom:** STATCOM current. **Top:** without SMES, **Bottom:** with SMES. [X-axis: Current in Amp].

nation of STATCOM and SMES, tested with a standard transmission line power system. Further, performances are ensured by the developed numerical model in simulation software under various designed working conditions. It is confirmed that the real power flow from STATCOM with SMES to power lines are enhanced during peak loaded conditions. Moreover, the reactive power compensated in both inductive and capacitive modes of operation, which in turn enhanced the real power. Finally, this investigation work confirms that STATCOM with SMES proved to enhance the ATC in existing transmission system with feasible operation.

References

- [1] S. Yoshihiko, H. Yoshinobu, T. Hasegawa, New static VAR control using force commutated inverters, *IEEE Trans. Power App. System* 100 (9) (1981) 4216–4224.
- [2] G.D. Galanos, Advanced static compensator for flexible ac transmission, *IEEE Trans. Power Systems* 8 (1) (1993) 113–119.
- [3] C.D. Collins, G.N. Bathurst, N.R. Watson, A.R. Wood, 2, 2005, pp. 194–200. *IEE Proc. Generation Transmission and Distribution*.
- [4] G.J. Wakiesh, *Power Systems Harmonics Fundamentals, Analysis and Filter Design*, Springer International ed., 2010.
- [5] A. Arsoy, Y. Liu, S.S. Chen, Dynamic performance of a static synchronous compensator with energy storage, *IEEE Conf. Proc. Power Eng., Society Winter Meeting 2* (2001) 605–610.
- [6] L. Wenhua, L. Xu, L. Feng, L. Chenglian, G. Hang, Development of 20 MVA static synchronous compensator, *IEEE Conf. Proc. Power Eng., Society Winter Meeting 4* (2000) 2648–2653.
- [7] M. Hasan Ali, B. Wu, A. Roger Dougal, An overview of SMES application in power and energy systems, *IEEE Trans. Sustain. Energy* 1 (1) (2010) 38–47.
- [8] C. Schauder, M. Gernhard, E. Stacey, T. Lemak, L. Gyugyi, T.W. Cease, et al., Development of a +/-100 MVar static condenser for voltage control of transmission system, *IEEE Trans. Power Delivery* 10 (3) (1995) 1486–1496.
- [9] M.S.E.I. Moursi, A.M. Sharaf, Novel reactive power controllers for the STATCOM and SSSC, *Electr. Pow. Syst. Res.* 76 (2006) 228–241.
- [10] H.M. Hasanien, A.Y. Abdelaziz, An adaptive-controlled superconducting magnetic energy storage unit for stabilizing a grid-connected wind generator, *Electr. Pow. Compo. Sys.* 43 (8–10) (2015) 1072–1079.
- [11] A. Rodríguez, F. Huerta, E.J. Bueno, F.J. Rodríguez, Analysis and performance comparison of different power conditioning systems for SMES-based energy systems in wind turbines, *Energies* 6 (3) (2013) 1527–1553.
- [12] I. Papic, Mathematical analysis of FACTS devices based on a voltage source converter, *Electr. Pow. Syst. Res.* 56 (2000) 149–157.
- [13] M.K. Jalboub, H.S. Rajamani, J.C. Readle, R.A. Abd-Alhameed, A.M. Ibbal, Weakest bus identification for optimal location for FACTS systems in multimachine power network, *Int. J. Power Energy Convers.* 3 (1/2) (2012) 127–142.
- [14] J. Chen, T.T. Lie, D.M. Vilathgamuwa, Damping of power system oscillations using SSSC in real time implementation, *Electr. Pow. Syst. Res.* 26 (2004) 357–364.
- [15] N. Mohan, *Power Electronics: Converters, Applications, and Design*, John Wiley & Son Inc, New York, 1995.
- [16] P. Sanjeevikumar, P. Pugazhendiran, V. Rajeswari, Improvement of power system voltage stability using fuzzy based index, *J. Electr. Eng.* 9 (3) (2009) 50–56.