

IN-07  
181548  
p-20

# Analysis of Gas Turbine Engines Using Water and Oxygen Injection to Achieve High Mach Numbers and High Thrust

Hugh M. Henneberry  
*Analex Corporation*  
*Brook Park, Ohio*

and

Christopher A. Snyder  
*Lewis Research Center*  
*Cleveland, Ohio*

July 1993

(NASA-TM-106270) ANALYSIS OF GAS  
TURBINE ENGINES USING WATER AND  
OXYGEN INJECTION TO ACHIEVE HIGH  
MACH NUMBERS AND HIGH THRUST  
(NASA) 20 p

N94-13143

Unclas

G3/07 0181548

The NASA logo, consisting of the word "NASA" in a bold, sans-serif font with a stylized "A".



# ANALYSIS OF GAS TURBINE ENGINES USING WATER AND OXYGEN INJECTION TO ACHIEVE HIGH MACH NUMBERS AND HIGH THRUST

Hugh M. Henneberry  
Analex Corporation  
3001 Aerospace Parkway  
Brook Park, Ohio 44142

and

Christopher A. Snyder  
National Aeronautics and Space Administration  
Lewis Research Center  
Cleveland, Ohio 44135

## SUMMARY

This report describes an analysis of gas turbine engines using water and oxygen injection to enhance performance by increasing Mach number capability and by increasing thrust. The liquids are injected, either separately or together, into the subsonic diffuser ahead of the engine compressor. A turbojet engine and a mixed-flow-turbofan engine (MFTF) are examined, and in pursuit of maximum thrust, both engines are fitted with afterburners. The results indicate that water injection alone can extend the performance envelope of both engine types by one and one-half Mach numbers at which point water-air ratios reach 17 or 18 percent and liquid specific impulse is reduced to some 390 to 470 sec, a level about equal to the impulse of a high energy rocket engine. The envelope can be further extended, but only with increasing sacrifices in liquid specific impulse.

Oxygen-airflow ratios as high as 15 percent were investigated for increasing thrust. Using 15 percent oxygen in combination with water injection at high supersonic Mach numbers resulted in thrust augmentation as high as 76 percent without any significant decrease in liquid specific impulse. The stoichiometric afterburner exit temperature increased with increasing oxygen flow, reaching 4822 °R in the turbojet engine at a Mach number of 3.5. At the transonic Mach number of 0.95 where no water injection is needed, an oxygen-air ratio of 15 percent increased thrust by some 55 percent in both engines, along with a decrease in liquid specific impulse of 62 percent. Afterburner temperature was approximately 4700 °R at this high thrust condition.

Water and/or oxygen injection are simple and straightforward strategies to improve engine performance and they will add little to engine weight. However, if large Mach number and thrust increases are required, liquid flows become significant, so that operation at these conditions will necessarily be of short duration.

## INTRODUCTION

In planning future aerospace programs, a good deal of attention is currently focused on airbreathing propulsion systems. In the civilian arena, gas turbine engines are being considered as the propulsion system for the first stage of a fully recoverable two-stage launch vehicle. Reference 1 describes one such vehicle which has evolved into the Beta II concept currently being investigated at the NASA Lewis Research Center. References 2 and 3 describe more recent versions of the vehicle, and reference 4 discusses propulsion concepts for the first stage of the Beta II vehicle. References 5 to 7 report on earlier studies which

included two-stage-to-orbit vehicles (TSTO) with various contributions from airbreathing propulsion. In the area of military aircraft, it can be assumed that there is a continuing interest in achieving acceleration levels and velocities in excess of those presently attainable. Therefore, it is possible that both civilian and military programs could benefit from the development of a gas turbine engine with high Mach number and high thrust capabilities.

Various gas turbine engines are being considered, including turbojets, turbine bypass engines, and several versions of the turbofan engine. All of these cycles are suitable for subsonic and transonic operation, but as the flight envelope is expanded to high Mach numbers, compressor inlet temperatures increase and eventually reach limits imposed by materials technology. Operation beyond these limits requires that the gas turbine engines be shut down or bypassed, and alternate propulsion systems such as a ramjet or rocket be used. Providing an alternate propulsion system results in added weight and complexity and impacts the design of the airplane.

The present analysis examines water injection as a means of reducing inlet air temperature and thereby extending the Mach number range of gas turbine engines. Water is injected into the inlet subsonic diffuser. As the water evaporates, it reduces the temperature of the flow entering the turbomachinery. Such a strategy is much simpler than the alternate propulsion schemes, and provides a further benefit by reducing peak cycle temperatures, thus facilitating the design of the engine afterburner and exhaust nozzle. Water injection is a technique which has been extensively studied and applied in the past, but usually as a strategy to augment thrust at subsonic and transonic Mach numbers. References 8 to 11 document some of this work. Reference 12 examines water injection as a strategy to improve engine-inlet matching at Mach numbers from 1.5 to 2.0. Reference 13 describes the Peace Jack program conducted on the J79-17 engine using water injection to improve its altitude and Mach number capability. The reference includes a description of the injection hardware as well as the facilities and instrumentation required in the program. Velocities up to Mach 2.3 were simulated. Reference 14 provides details of the Peace Jack water injection system installed on a version of the F-4 airplane. Because the program was limited to speeds below Mach 2.3, the amount of precompressor cooling which could be achieved was somewhat limited because the inlet air approached saturation at high water flows. In the present analysis water injection is only investigated at Mach numbers above 2.4, and saturation is not encountered even with large water flow rates.

The study also evaluates the thrust augmentation which can be achieved by injecting liquid oxygen ahead of the engine compressor. In order to maximize thrust, it is assumed that almost all of the injected oxygen is available in the afterburner for reaction with additional fuel. This leads to higher afterburner temperatures, but the effect is mitigated at high Mach numbers where water injection rates limit exhaust gas temperatures due to the heat sink capacity of the water vapor.

The analysis examines two gas turbine cycles at various Mach numbers and altitudes, and documents liquid flow rates, thrust and liquid specific impulse where the latter parameter is defined as thrust divided by the sum of water, oxygen and fuel flows.

## SYMBOLS AND ABBREVIATIONS

A	area, ft <sup>2</sup>
HPC	high pressure compressor
ICAO	International Civil Aviation Organization
LPC	low pressure compressor

M	Mach number
MFTF	mixed-flow turbofan
P	total pressure, lbf/ft <sup>2</sup>
q	incompressible dynamic pressure, lbf/ft <sup>2</sup>
T	total temperature, °R
TSTO	two-stage-to-orbit

Subscripts:

2,3,4,... thermodynamic states in gas turbine engines, refer to figure 1

## ANALYSIS

Figure 1 displays schematic sections of the two engines investigated, a single spool turbojet and a two spool mixed-flow turbofan. The turbojet is intended to represent an appropriate design for the accelerator stage of a TSTO launch vehicle, assuming that the engine would be developed mainly for this application. The turbojet engine might also be suitable for an advanced military airplane. The turbofan is intended to represent a possible derivative of an engine which is being studied for the High Speed Civil Transport airplane. If such an engine could be adapted for the TSTO accelerator stage, development costs could be greatly reduced.

Suitable supersonic Mach number ranges were chosen for each engine, and both water and oxygen injection were investigated. Three altitude-Mach number schedules were examined for each engine. The schedules, characterized as low, normal, and high are displayed in table I along with the dynamic pressures resulting from each schedule. In all cases, dynamic pressure is reduced at the highest Mach numbers, recognizing that staging will occur at or near these conditions. Transonic performance was briefly analyzed, and oxygen injection at this condition was included in the study. Penalties resulting from lip drag, nacelle drag, and inlet bleed flows were not included in the calculations, and only uninstalled net thrust is reported.

The injected liquids were introduced in the inlet subsonic diffuser ahead of the fan or compressor depending on the engine type in order to provide acceptable compression system entrance temperatures, even at high flight Mach numbers. Fan inlet temperature was limited to 838 °R in the MFTF engine and compressor inlet temperature was limited to 1332 °R in the turbojet. The lower limit for the turbofan is consistent with the cruise Mach number of 2.4 presently being proposed for the High Speed Civil Transport airplane. The higher limit assigned to the turbojet engine represents ram temperature at Mach 3.5. The SR-71 airplane has already achieved a speed greater than Mach 3.2, and the Mach 3.5 temperature chosen here represents a realistic goal for propulsion development in the year 2000 time period, assuming an engine duty cycle with operation of limited duration at high Mach numbers. Compressor outlet temperature was limited to 1771 °R in both engines. It was chosen to be consistent with the compressor material temperature limits, and again was assumed to represent development in the year 2000 time period. In all cases, hydrocarbon fuel was assumed. The ICAO atmosphere was adhered to throughout the study except for the deletion of minor constituents in the ICAO definition of standard air.

The NEPP computer code, documented in reference 15, was used for all cycle calculations. This code analyzes the thermodynamic processes in the engine cycle and accounts for gas properties even in the presence of water and oxygen diluents. Although dissociation effects were not significant in this study, the

code uses gas properties consistent with dissociation to equilibrium conditions throughout the thermodynamic processes.

The NEPP code requires input of appropriate compressor and turbine maps. Since the range of variables included in the study resulted in high temperatures and in very substantial water and oxygen injection rates, it was necessary to account for the effects of these temperatures and diluents on compressor and turbine performance.

The turbine maps were generated using the PART code described in reference 16. This program allows the user to assign appropriate values for the properties of the turbine working fluid. In this way, the effects of temperature and diluents could be accounted for and no further corrections to the turbine maps were necessary.

In contrast to this, compressor maps were generated using the CMGEN code described in reference 17. The maps so obtained are based on corrected conditions. Since the NEPP program assumes the working fluid has a specific heat ratio of 1.4 and a molecular weight of 28.97, correction factors were required to account for the variance from standard values caused by the large diluent flows in the gas stream entering the compression system. It was, therefore, necessary to examine the effects of nonstandard properties on compressor performance.

Effect of Fluid Properties on Compressor Performance.—Nonstandard fluid conditions are dealt with in reference 18 which examines deviations in molecular weight and in specific heat ratio. The reference deals with corrections to turbine performance where high temperatures and dilution from combustion products distort gas properties at the turbine inlet. These methods are valid for correcting compressor performance and, therefore, were used in the present analysis.

The effect of nonstandard properties on compressor flow capacity is summarized in table II for both engines, where the flow correction factor is defined as the ratio of actual compressor flow to the flow which would be realized with standard fluid properties. In the case of the MFTF engine, compressor inlet refers to the fan or low-pressure compressor (LPC), and compressor exit refers to the high-pressure (HPC). Table II applies to conditions encountered with the normal altitude-Mach number schedule. Only negligible differences occur when the other two schedules are examined. Water flow rates were determined either by compressor inlet or exit temperature limits, as previously described. The exit temperature limit was more restrictive in the case of the turbojet engine at Mach 3.5, where compressor inlet temperature had to be reduced to 1222 °R to satisfy the compressor exit limit. At all other Mach numbers, the compressor inlet limit was more restrictive, and this was true as well at all Mach numbers for the MFTF engine. Water injection temperature was chosen as 537 °R throughout the analysis.

The required corrections are negligible at low Mach numbers and result in flow deficiencies of 6 to 7 percent at the high Mach numbers where water flow rates are high. The analytical program uses standard properties, causing it to overpredict compression system mass flow for a given speed. This was corrected by increasing rotor speed so that actual flow with the nonstandard properties was made equal to the flow expected from the compressor map based on standard properties. When oxygen injection was present, water flow rates decreased somewhat because some cooling results from the addition of liquid oxygen. Oxygen causes less severe distortions in specific heat ratio and molecular weight, and therefore, flow correction factors are closer to unity. In the turbojet engine, for example, limiting compressor temperatures as in the previous table, and considering an oxygen-airflow ratio of 0.15, results in a correction factor of 0.944 at Mach 5.5, contrasted to 0.927 with water injection only, an increase of 1.8 percent. The change is proportional to oxygen-airflow ratio and vanishes when the oxygen injection

rate reaches zero. Similar differences were observed in the MFTF engine, again ranging from 1.8 percent down to zero.

A correction factor for compressor pressure ratio was also obtained. However, within the range of fluid properties encountered in this study, deviations in pressure ratio were very small, never exceeding one-half of 1 percent. As a consequence, no correction for pressure ratio was included in the analysis. Also, since corrections for flow rates were included in the calculations, Mach numbers in the compressors were found to be virtually unchanged from those prevailing with standard conditions; therefore, no corrections for compressor efficiency were included.

### Engine Design Parameters

Assumptions required for the cycle analyses were intended to be consistent with development commencing in the year 2000 time period. Results are presented for a single engine size, namely compressor tip diameters of 60.6 in. for the turbojet compressor and for the low pressure compressor of the MFTF engine. The effects of Reynolds number and other scale factors were not included in the study. Therefore, except for this minor qualification, the results can be adjusted to represent any engine size by recognizing that liquid flow rates, areas, and thrust are proportional to airflow. Temperature, pressure and specific impulse are, of course, unaffected by engine size.

The inlet recovery schedule was derived from Military Specification 5007D, and could probably be achieved with a two-dimensional mixed-flow design featuring two external compression surfaces and some internal contraction. Variable geometry would be required as would boundary layer and shock position control. Although installation losses were not analyzed, nozzle exit area was chosen to be consistent with a reasonable nacelle geometry. An exit area of 35 ft<sup>2</sup> was found to satisfy the geometry constraint for both engines. The nozzle exit area was fixed at this value throughout the analysis and resulted in overexpansion of the exhaust gases at subsonic Mach numbers and underexpansion at Mach numbers above transonic. Overexpanded nozzle performance was calculated by assuming flow separation at a static pressure equal to 40 percent of ambient. The negative thrust developed in the separated region was obtained by assuming average static pressure in the region was equal to 70 percent of ambient pressure. Both engines require exhaust nozzles with variable throat areas.

The engines were assumed to be appropriate for the acceleration of an airbreathing boost vehicle or for an advanced military airplane. In both applications, high thrust and high Mach numbers are important and, therefore, only maximum thrust conditions were investigated. This resulted in stoichiometric combustion in the afterburners, after recognizing that some oxidant is not available for combustion; since it is required to cool the afterburner liner and the exhaust nozzle.

Water and oxygen pump requirements were briefly analyzed to determine the level of power required for their operation. Only conditions along the normal altitude schedule were examined, and assumptions included an estimate of pump efficiency and a pump discharge pressure equal to twice compressor inlet total pressure. It was found that maximum required water pump power was some 23 hp, and the maximum oxygen pump requirement was approximately 26 hp. These values are well within the normal 200 shaft horsepower extraction assumed for all conditions in the cycle calculations. Because the oxygen would probably be loaded at atmospheric pressure and would be near its boiling point of 162 °R at this pressure, it would be necessary to provide a boost pump near the tank outlet if the main oxygen pump is to be driven as an engine accessory. The boost pump would supply adequate pressure to the suction side of the engine-driven pump in a manner consistent with oxygen systems in rocket vehicles.

Turbojet.—The turbojet engine was conceived as a single spool design with a high compressor having six stages driven by a turbine with one and one-half stages (one stage turbine with exit guide vanes to straighten the flow). Maximum turbine inlet temperature was chosen as 3250 °R. Beyond transonic Mach numbers, high turbine inlet temperature is much less important from a cycle standpoint especially with maximum augmentation. Therefore, it was reduced to 3000 °R in the interest of engine life and maintainability. Engine design parameters are displayed in table III.

Inlet capture area was fixed and was chosen to provide critical (shock-on-lip) operation with the engine operating at 93.9 percent of design mechanical speed at Mach 3.5. The inlet would be subcritical at supersonic Mach numbers below 3.5, but because little or no water injection is required at these conditions, flight points between Mach 0.95 to 3.5 were not included in the analysis. At Mach numbers of 4.0 and 4.5, it was assumed that matched inlet flow and recovery were maintained by reducing engine speed. However, at Mach 5.0 and 5.5 this strategy would result in unacceptably low compressor corrected speeds. Therefore, at flight velocities in excess of Mach 4.5, engine rotor speed was held constant at the Mach 4.5 value. As a consequence, the normal shock would move closer to the subsonic diffuser exit and would increase in strength, resulting in a decrease in inlet recovery.

To account for the presence of liquid injection apparatus in the subsonic diffuser, a total pressure drop of 5 percent was assumed when no water injection was required and the pressure drop was reduced to 2.5 percent when water injection was present. This reduction in pressure loss roughly accounts for the increase in total pressure which results from the cooling provided by the water injection. In a similar manner, additional pressure drops of 5 or 2.5 percent were assessed when oxygen injection was investigated.

The analysis assumed that 13 percent of compressor exit flow was bled off to provide for necessary turbine cooling. It was further assumed that 10 percent of the remaining compressor exit flow was bled off to provide cooling for the afterburner liner and exhaust nozzle.

Mixed-flow turbofan engine.—The turbofan engine was conceived as a two spool design with a low pressure spool consisting of three or four fan stages driven by a turbine with two and one-half stages. The high pressure spool could consist of one or two turbine stages driving six compressor stages. High flow designs were specified for both compressors. Water injection rates were designed to limit the LPC inlet temperature to 838 °R, and this resulted in HPC exit temperatures which did not exceed an acceptable 1771 °R. Other assumptions for the MFTF cycle corresponded to those chosen for the turbojet wherever possible. The turbofan inlet recovery schedule was identical to that specified for the turbojet, but inlet critical flow was matched to engine flow at Mach 2.4 with the LPC operating at 100 percent of design mechanical speed. Performance was not investigated at supersonic Mach numbers below 2.4 where inlet operation would be subcritical. Operation at Mach numbers above 2.4 was similar to the turbojet strategy, with matched inlet flow and recovery maintained to Mach 3.5. Above this Mach number, LPC speed was held constant at the Mach 3.5 value, resulting in supercritical inlet operation. Bypass flow did not exceed 43 percent of core flow except at Mach 2.4. Bypass ratio was increased to 84 percent for this one point to maintain a reasonable turbine rotor inlet temperature and preserve the comparison with the turbojet engine. Bypass ratio could have been decreased by increasing turbine rotor inlet temperature or by choosing a lower design point turbine inlet temperature.

It was assumed that 10 percent of the LPC exit flow was bled off to cool the afterburner liner and exhaust nozzle. In addition, 13 percent of the HPC exit flow was bled off to cool the turbines. Other MFTF design parameters are included in table III.



## RESULTS

The analytical results for both engines are summarized in table IV which applies to the normal altitude-Mach number schedule. The results for oxygen injection are not included in table IV and will be presented later. Water injection flows reached 24 to 26 percent of airflow at the highest Mach numbers, namely Mach 5.5 for the turbojet and Mach 4.5 for the turbofan. Saturation of the inlet air is not possible in the turbojet engine because compressor inlet temperature was only reduced to 1332 °R, some 167 °R above the critical temperature of water. In the case of the MFTF engine where compressor inlet temperature was reduced to 838 °R, saturation was also not encountered or even approached. At the extreme Mach number of 4.5, and an altitude of 82 200 ft as called for in the low altitude schedule, relative humidity of the inlet air after water injection was only 4.3 percent. At all other flight conditions, relative humidity was less than 4.3 percent; thus it appears that no difficulties will be encountered in achieving complete evaporation of the injected water.

Liquid specific impulse at the highest Mach numbers was 287 sec for the turbojet and 343 sec for the turbofan. These impulse values could be equalled or exceeded with high energy rocket propulsion; thus for a TSTO vehicle, optimum staging might be below these Mach numbers, although many other factors would enter into the choice of staging Mach number.

Afterburner area was fixed at 1.25 times compressor frontal area for both engines. This resulted in afterburner exit Mach numbers below 0.35 for both engines, except for the MFTF at Mach 2.4, where afterburner outlet Mach number was 0.46. This was a consequence of the high bypass ratio required at this condition which led to a relatively low turbine outlet pressure and hence a high afterburner Mach number. Turbojet rotor speed and MFTF low spool rotor speed were chosen in all cases to maximize thrust, within the constraint imposed by fixed inlet area. Resulting mechanical speeds varied from 100 to 58 percent in the turbojet engine, and from 100 to 53 percent in the MFTF.

Table IV lists engine pressure ratio  $P_5/P_2$ , for both engines. This parameter is useful in evaluating the performance of the gas generator portion of the cycle, and is important at subsonic Mach numbers where little or no ram pressure is present. At high Mach numbers, its importance is greatly diminished because ram compression eclipses the pressure contribution from the gas generator cycle. At low Mach numbers the MFTF engine enjoys a small advantage in engine pressure ratio over the turbojet due to its high overall compressor pressure ratio of 27, compared to 12 for the turbojet. At high Mach numbers the MFTF has a larger advantage in  $P_5/P_2$ , but as stated, this parameter is less important at these conditions.

Other parameters are displayed in table IV, including cycle temperatures, compressor efficiencies, and exhaust nozzle throat areas, along with values of thrust and liquid specific impulse.

Performance at supersonic Mach numbers.—Pertinent data from table IV are plotted in figure 2 to reveal the effect of Mach number on performance of the two engines. Thrust is seen to be relatively flat when dynamic pressure is constant, but as would be expected, thrust decreases markedly at the low dynamic pressures occurring at the high Mach numbers where staging is assumed to occur. Liquid specific impulse declines rapidly as water flows increase with increasing Mach number. The effect is similar in both engines, but is shifted to higher Mach numbers in the turbojet engine with its greater compressor inlet temperature tolerance.

Effect of altitude.—The curves of figure 2 are repeated in figures 3 and 4 along with additional curves which define performance for the high and low altitude schedules. The figures also include data for a Mach number of 0.95, which is representative of a subsonic cruise point. Water-air ratio, specific impulse

and afterburner temperature are not sensitive to changes in altitude, being affected only by changes in ambient temperature. These temperature changes were small over the range of altitudes studied. Thrust is a strong function of altitude, being proportional to compressor inlet pressure. If corrected thrust were plotted in figures 3 and 4, data for the three altitude schedules would be virtually identical. As noted previously, the thrust curves decline at the highest Mach numbers where dynamic pressure is reduced in anticipation of staging.

Effect of oxygen injection.—Oxygen injection rates up to 15 percent of airflow were investigated at Mach numbers of 0.95 and above. The results are displayed in figures 5 and 6 for the normal altitude schedule. Focusing on the turbojet results displayed in figure 5: Water-air ratio declined as oxygen injection increased, due to the cooling capacity of the oxygen. Because the oxygen reacts with additional fuel in the afterburner, exhaust velocity increases so that thrust increases along with oxygen flow. The effect is enhanced by the increase in exhaust mass flow resulting from the addition of oxygen and extra fuel. At the Mach numbers included in figure 5, thrust was augmented some 50 to 75 percent at an oxygen-air ratio of 0.15. Oxygen injection degraded impulse at Mach numbers of 0.95 and 3.5, where little or no water injection is required. At the higher Mach numbers, where water injection rates are high, impulse is low without oxygen addition, but does not decrease as oxygen is added, even increasing slightly along the Mach 5.5 curve. This is a significant result when applied to airplane and trajectory analyses. In such analyses, engine thrust displays considerable leverage in decreasing acceleration time because of large drag and gravity losses. Thus, an increase in engine thrust with impulse virtually constant, results in decreased liquid requirements because acceleration time decreases out of proportion to the increase in liquid flow. However, it should be noted that this occurs only at high Mach numbers where water injection rates are high and liquid specific impulse is low, in the range of 300 to 500 sec.

Similar results are displayed in figure 6 for the MFTF engine. Again, large increases in thrust are realized as oxygen injection rates reach 15 percent of airflow. Liquid specific impulse was degraded some 60 percent at Mach 0.95 and Mach 2.4 where no water injection is required. A turbine inlet temperature of 3250 °R was specified at Mach 0.95 throughout the analysis. However, in the MFTF engine at Mach 0.95 and with an oxygen injection rate of 15 percent, this turbine inlet temperature would position the HPC operating point very near the surge region, so it was necessary to reduce turbine inlet temperature to 3193 °R at this point to provide an adequate surge margin. At the higher Mach numbers, impulse was not greatly affected by oxygen injection, the Mach 4.5 curve being essentially flat. Afterburner exit temperatures were almost identical to those observed in the turbojet engine, reaching 4750 °R at Mach 4.5 with a 15 percent oxygen injection rate.

## CONCLUSIONS

The analysis examined water injection and oxygen injection in two gas turbine engines, namely a turbojet and a mixed-flow turbofan. Water injection was found to be an effective method of controlling compressor temperatures while expanding the Mach number envelope of the two engines. However, liquid specific impulse decreased rapidly as Mach numbers were increased. In both engines, water injection rates of some 18 percent of airflow were required to increase engine capability one and one-half Mach numbers above their nominal maximum speed when operated dry. Impulse declined by 66 to 73 percent when the one and one-half Mach number increase was achieved, reaching values almost equivalent to the impulse which could be realized with high energy rocket propulsion. The analysis also examined velocities some two Mach numbers beyond the dry capability of the engines. In these cases, water injection rates reached 24 to 26 percent of airflow, and liquid specific impulse was degraded to 287 sec in the turbojet and to 343 sec in the MFTF engine. In applying the results to the TSTO mission, these low impulse values suggest that staging should occur at or near these points.

Altitude effects were briefly analyzed and, predictably, had little effect on required water-airflow ratios, impulse values and cycle temperatures. Predictably, thrust was shown to be a strong function of altitude, being proportional to compressor inlet pressure.

Oxygen injection was found to be an effective method of thrust augmentation. The injected oxygen was always combined with additional fuel in the afterburner to achieve nearly stoichiometric conditions. Oxygen flow rates up to 15 percent of airflow were analyzed, and the results were similar for both engine cycles. At the lower Mach numbers where no water injection is required, thrust augmentation reached 50 to 60 percent, along with a decrease in liquid specific impulse of some 60 percent. At high Mach numbers, where water injection was present, oxygen injection achieved similar augmentation ratios, but with little or no decrease in liquid specific impulse. The flat impulse-oxygen rate curves are significant because they could result in decreased liquid requirements in actual supersonic missions. Afterburner temperatures increased with increasing oxygen flow rates, but this result was restrained by the presence of water injection. Maximum temperature was encountered in the turbojet engine at Mach 3.5 with an oxygen flow rate of 15 percent, where the afterburner temperature reached 4822 °R.

The analytical results indicate that water and oxygen injection are simple and straightforward strategies that can expand the performance envelopes of the gas turbine engines studied. However, penalties in liquid specific impulse accompany these improvements, so that operation at these conditions will necessarily be of limited duration.

#### REFERENCES

1. Paris, S.W., et al.: Research Vehicle Configurations for Hypervelocity Vehicle Technology. Report WRDC-TR-90-3003-VOL-1: Hypervelocity Vehicle Configurations. Boeing Aerospace and Electronics Co., Seattle, WA, 1990.
- 1a. Wetzel, E.D., et al.: Research Vehicle Configurations for Hypervelocity Vehicle Technology. Report WRDC-TR-90-3003-VOL-2: Development of a Two Stage Launch System. Boeing Aerospace and Electronics Co., Seattle, WA, 1990.
2. Plencner, R.M.: Overview of the Beta II Two-Stage-To-Orbit Vehicle Design. NASA TM-105298, 1991. (Also, AIAA Paper 91-3175.)
3. Burkardt, L.; and Norris, R.: The Design and Evolution of the Beta Two-Stage-To-Orbit Horizontal Takeoff and Landing System. AIAA Paper 92-5080, 1992.
4. Snyder, C.A.; and Maldonado, J.: The Design and Performance Estimates for the Propulsion Module for the Booster of a TSTO Vehicle. NASA TM-105299, 1991. (Also, AIAA Paper 91-3136.)
5. Martin, J.A.: Orbit on Demand: In This Century if Pushed. *Aerosp. Am.*, vol. 23, Feb. 1985, pp. 46-48.
6. MacConochie, I.D., et al.: Will Cost Determine Best Design? *Aerosp. Am.*, vol. 23, Feb. 1985, pp. 50-53.
7. Taylor, A.H., et al.: Orbit on Demand: Structural Analysis Finds Vertical Launchers Weigh Less. *Aerosp. Am.*, vol. 23, Feb. 1985, pp. 58-61.

8. Hall, E.W.; and Wilcox, E.C.: Theoretical Comparison of Several Methods of Thrust Augmentation for Turbojet Engines. NACA, LFPL RM-E8H11, Oct. 27, 1948.
9. Lundin, B.T.: Theoretical Analysis of Various Thrust-Augmentation Cycles for Turbojet Engines. NACA, LFPL TN-2083, May 1950.
10. Wilcox, E.C.; and Trout, A.M.: Analysis of Thrust Augmentation of Turbojet Engines by Water Injection at Compressor Inlet Including Charts for Calculating Compression Processes With Water Injection. NACA, LFPL TN-2105, June 1950.
11. Sivo, J.N.; Wanhainen, J.P.; and Jones, W.L.: The Effect of Compressor-Inlet Water Injection on Engine and Afterburner Performance. NACA RM-E58D036, 1958.
12. Beke, A.: Analytical Investigation of the Effect of Water Injection on Supersonic Turbojet-Engine-Inlet Matching and Thrust Augmentation. NACA TN-3922, 1957.
13. Kirkland, F.P.: Peace Jack—Water Spray System Development Test Final Report. Vol. I: Data Analysis. Report FZT 68-005. General Dynamics, Fort Worth Division, Fort Worth, TX, 1975.
14. Evans, R.L.: Peace Jack—Precompressor Cooling System (PCC) Design and Analysis Report. Report FZT 628-015. General Dynamics, Fort Worth Division, Fort Worth, TX, 1975.
15. Plencner, R.M.; and Snyder, C.A.: The Navy/NASA Engine Program (NNEP89)—A User's Manual. NASA TM-105186, 1991.
16. Converse, G.L.: Extended Parametric Representation of Compressor, Fans and Turbines, Vol. II—PART User's Manual (Parametric Turbine). NASA CR-174646, 1984.
17. Converse, G.L.: Extended Parametric Representation of Compressor, Fans and Turbines, Vol. I—CMGEN User's Manual. NASA CR-174645, 1984.
18. Glassman, A.J.: Turbine Design and Application, Vol. I. NASA SP-290, 1972.

TABLE 1.—ALTITUDE-MACH NUMBER  
SCHEDULES

(a) Turbojet engine

Flight Mach number	Schedule	Altitude, ft	Dynamic pressure $q$ , lbf/ft <sup>2</sup>
0.95	Low	7 800	1000
	Normal	15 200	750
	High	24 800	500
3.5	Low	65 400	1000
	Normal	71 600	750
	High	80 000	500
4.5	Low	76 000	1000
	Normal	82 200	750
	High	90 900	500
5.5	Low	90 800	750
	Normal	99 800	500
	High	115 500	250

(b) Mixed-flow turbofan engine

0.95	Low	7 800	1000
	Normal	15 200	750
	High	24 800	500
2.4	Low	49 600	1000
	Normal	55 600	750
	High	64 100	500
3.5	Low	65 400	1000
	Normal	71 600	750
	High	80 000	500
4.5	Low	82 200	750
	Normal	90 800	500
	High	106 000	250

TABLE II.—FLOW CORRECTION FACTORS

Engine	Flight Mach number	Water-air ratio	Compressor inlet temperature, °R	Compressor exit temperature, °R	Flow correction factor
Turbojet	3.5	0.0217	1222	1771	0.980
	4.5	.112	1332	1556	.957
	5.5	.258	1332	1551	.927
Mixed Flow Turbofan	2.4	0	837	1771	0.997
	3.5	.106	838	1383	.967
	4.5	.243	838	1368	.937

TABLE III.—ENGINE DESIGN PARAMETERS

(a) Turbojet engine

Inlet recovery schedule	Derived from Mil. Spec. 5007D
Compressor tip diameter, in.	60.6
Primary combustion efficiency	0.995
Afterburner combustion efficiency	0.95
Exhaust nozzle exit area, ft <sup>2</sup>	35.0
Exhaust nozzle velocity coefficient	0.985
At sea level static design point:	
Compressor tip speed, ft/sec	1400
Compressor pressure ratio	12.0
Compressor polytropic efficiency	0.90
Turbine inlet temperature, °R	3250
Turbine adiabatic efficiency	0.89

(b) Mixed-flow turbofan engine

Inlet recovery schedule	Derived from Mil. Spec. 5007D
LPC tip diameter, in.	60.6
HPC tip diameter, in.	51.5
Primary combustion efficiency	0.995
Afterburner combustion efficiency	0.95
Exhaust nozzle exit area, ft <sup>2</sup>	35.0
Exhaust nozzle velocity coefficient	0.985
At sea level static design point:	
LPC tip speed, ft/sec	1400
LPC pressure ratio	4.30
LPC polytropic efficiency	0.90
Bypass ratio	0.25
HPC tip speed, ft/sec	1380
HPC pressure ratio	6.325
HPC polytropic efficiency	0.90
Turbine inlet temperature, °R	3250
High Pressure Turbine adiabatic efficiency	0.89
Low Pressure Turbine adiabatic efficiency	0.89

TABLE IV.—SUMMARY OF RESULTS FOR NORMAL ALTITUDE-MACH NUMBER SCHEDULE,  
NO OXYGEN INJECTION

(a) Turbojet engine

Flight Mach number, $M_0$	0	0.95	3.5	4.0	4.5	5.0	5.5
Altitude, ft	0	15 200	71 600	77 200	82 200	95 600	99 800
Dynamic pressure, $q$ , lbf/ft <sup>2</sup>	0	749	745	747	748	498	497
Inlet recovery, including injector $\Delta P$ , $P_2/P_0$	0.884	0.884	0.720	0.650	0.575	0.352	0.223
Free stream total temperature $T_0$ , °R	518.7	548.4	1331	1611	1921	2285	2660
Water-air ratio	0	0	0.0217	0.0528	0.112	0.183	0.258
Compressor inlet total temperature $T_2$ , °R	518.7	548.4	1222	1332	1332	1332	1332
Compressor inlet total pressure $P_2$ , lbf/ft <sup>2</sup>	1870	1872	4847	6799	9317	5852	5630
Water plus airflow, lbm/sec	651.0	610.4	449.6	404.6	379.0	239.1	230.7
Corrected water plus airflow, lbm/sec	736.8	709.6	301.3	201.8	137.9	138.6	138.8
Rotor mechanical speed, percent	100	100	93.9	73.6	57.6	59.0	59.6
Rotor corrected speed, percent	100	97.3	61.2	45.9	36.3	36.8	37.2
Compressor adiabatic efficiency	0.861	0.864	0.721	0.626	0.599	0.602	0.605
Compressor pressure ratio, $P_3/P_2$	12.00	11.22	2.96	1.91	1.46	1.47	1.47
Compressor exit temperature $T_3$ , °R	1128	1164	1771	1713	1556	1555	1551
Turbine inlet temperature $T_4$ , °R	3250	3250	3000	3000	3000	3000	3000
Engine pressure ratio, $P_6/P_2$	4.12	3.80	0.95	0.85	0.89	0.89	0.89
Overall equivalence ratio	0.913	0.913	0.913	0.913	0.913	0.913	0.913
Afterburner exit temperature $T_6$ , °R	4064	4074	4270	4235	4076	3865	3680
Afterburner exit Mach number, $M_6$	0.27	0.28	0.34	0.23	0.14	0.14	0.14
Exhaust nozzle throat area $A_7$ , ft <sup>2</sup>	11.5	11.7	14.2	10.0	6.3	6.2	6.1
Uninstalled net thrust, lbf	67 420	63 280	42 310	37 170	34 290	19 310	16 850
Liquid specific impulse, lbf/(lbm/sec)	1662	1664	1145	840	576	389	287

TABLE IV.—Concluded.

## (b) Mixed-flow turbofan engine

Flight Mach number, $M_0$	0	0.95	2.4	3.0	3.5	4.0	4.5
Altitude, ft	0	15 200	55 600	65 000	71 600	85 800	90 800
Dynamic pressure, $q$ , lbf/ft <sup>2</sup>	0	749	751	749	745	500	502
Inlet recovery including injector $\Delta P$ , $P_2/P_0$	0.884	0.884	0.834	0.784	0.720	0.426	0.258
Free stream total temperature $T_0$ , °R	518.7	548.4	837.1	1082	1331	1629	1942
Water-air ratio	0	0	0	0.0524	0.106	0.172	0.243
LPC inlet total temperature $T_2$ , °R	518.7	548	837	838	838	838	838
LPC inlet total pressure $P_2$ , lbf/ft <sup>2</sup>	1870	1872	2280	3454	4847	2988	2819
Water plus airflow, lbm/sec	651.0	614.1	482.5	405.2	361.6	223.0	210.4
Corrected water plus airflow, lbm/sec	736.8	714.0	568.8	315.5	200.7	200.6	200.8
LPC mechanical speed, percent	100	100	100	70.9	52.2	52.7	53.2
LPC corrected speed, percent	100	97.3	78.7	55.8	41.1	41.5	41.9
LPC adiabatic efficiency	0.878	0.885	0.831	0.885	0.851	0.851	0.851
LPC pressure ratio	4.30	4.19	2.50	1.92	1.45	1.45	1.45
Bypass flow, lbm/sec	162.8	151.6	220.4	109.6	106.9	66.5	62.9
HPC pressure ratio	6.32	6.14	4.73	4.40	3.64	3.64	3.64
HPC exit temperature $T_3$ , °R	1479	1515	1771	1570	1383	1374	1368
Turbine inlet temperature $T_4$ , °R	3250	3250	3250	3000	3000	3000	3000
Engine pressure ratio, $P_5/P_2$	4.55	4.31	1.64	1.90	1.54	1.54	1.54
Overall equivalence ratio	0.900	0.900	0.900	0.905	0.910	0.915	0.919
Afterburner exit temperature $T_6$ , °R	4079	4091	4185	4017	3837	3618	3419
Afterburner exit Mach number $M_6$	0.24	0.24	0.46	0.19	0.14	0.14	0.14
Exhaust nozzle throat area $A_7$ , ft <sup>2</sup>	10.4	10.3	18.9	8.4	6.4	6.3	6.2
Uninstalled net thrust, lbf	69 340	65 580	50 660	44 940	37 700	20 860	17 770
Liquid specific impulse, lbf/(lbm/sec)	1734	1739	1709	1023	687	468	343



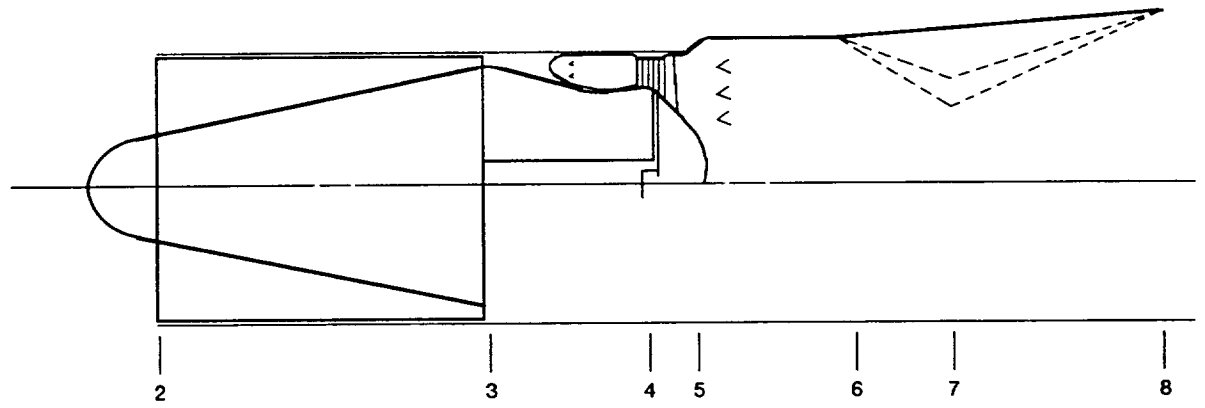

(a) Turbojet engine.

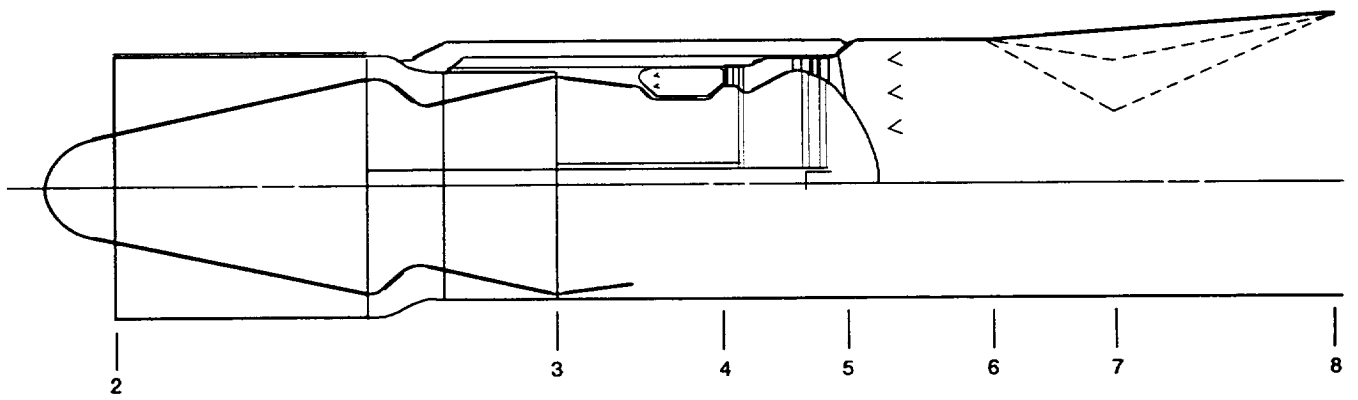

(b) Mixed-flow turbofan engine.

Figure 1.—Schematic drawings of gas turbine engines.

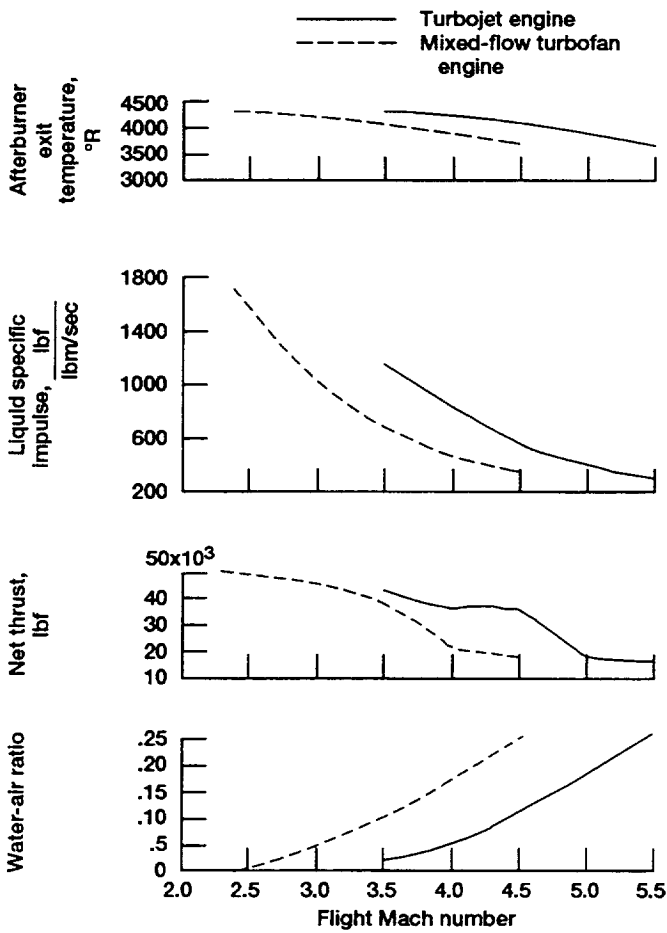

Figure 2.—Performance of gas turbine engines with water injection at high Mach numbers. Normal altitude schedule.

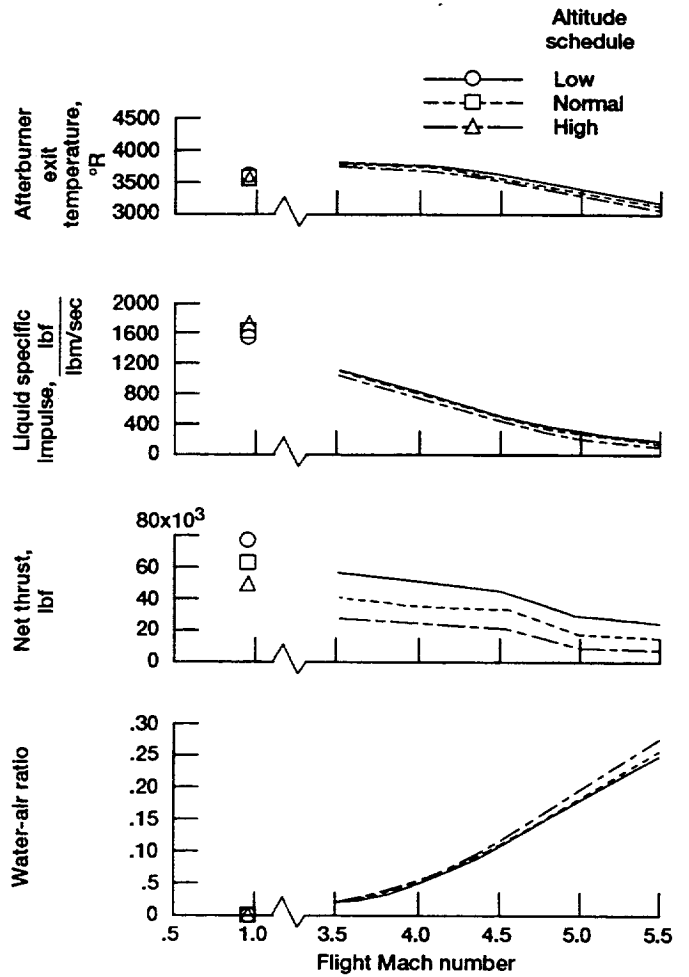

Figure 3.—Performance of turbojet engine with water injection. Three altitude schedules.

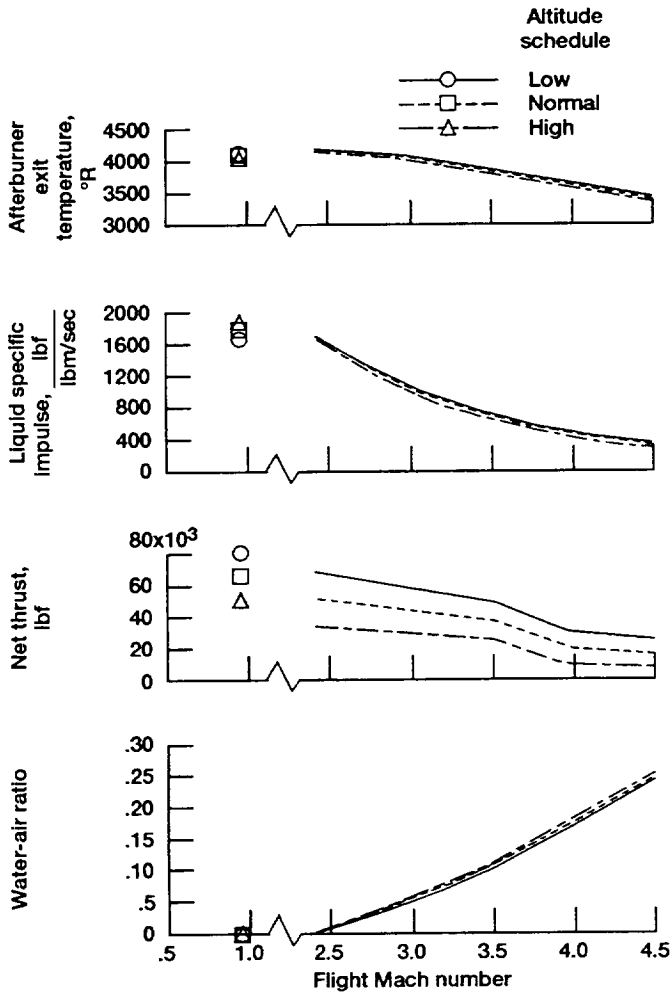

Figure 4.—Performance of mixed-flow turbofan engine with water injection. Three altitude schedules.

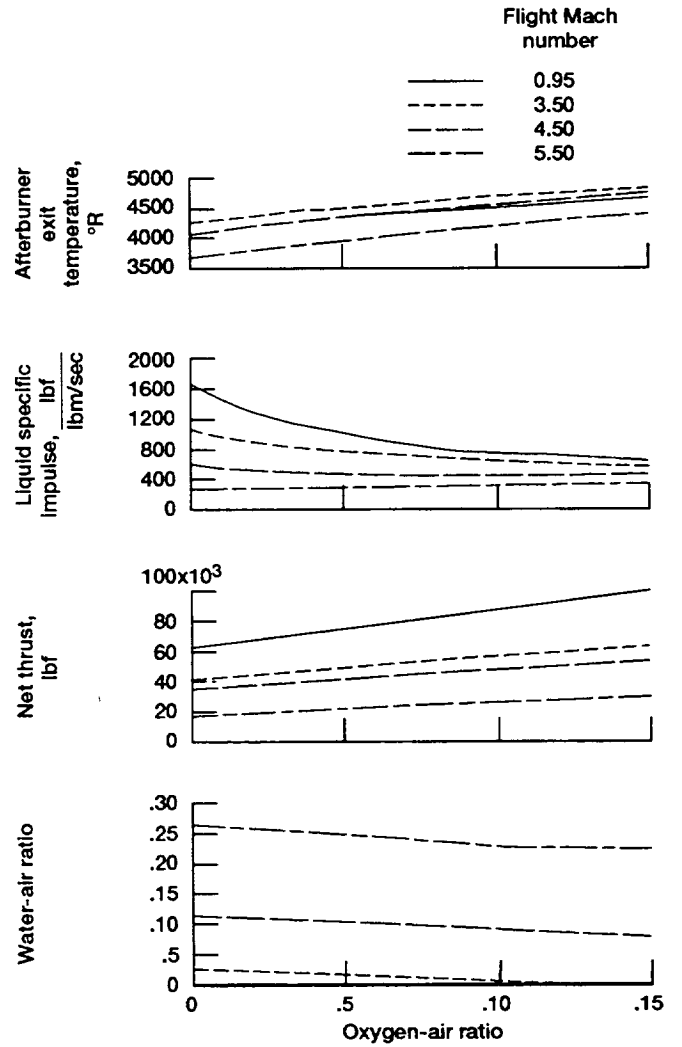

Figure 5.—Effect of oxygen injection on performance of turbojet engine. Normal altitude schedule.

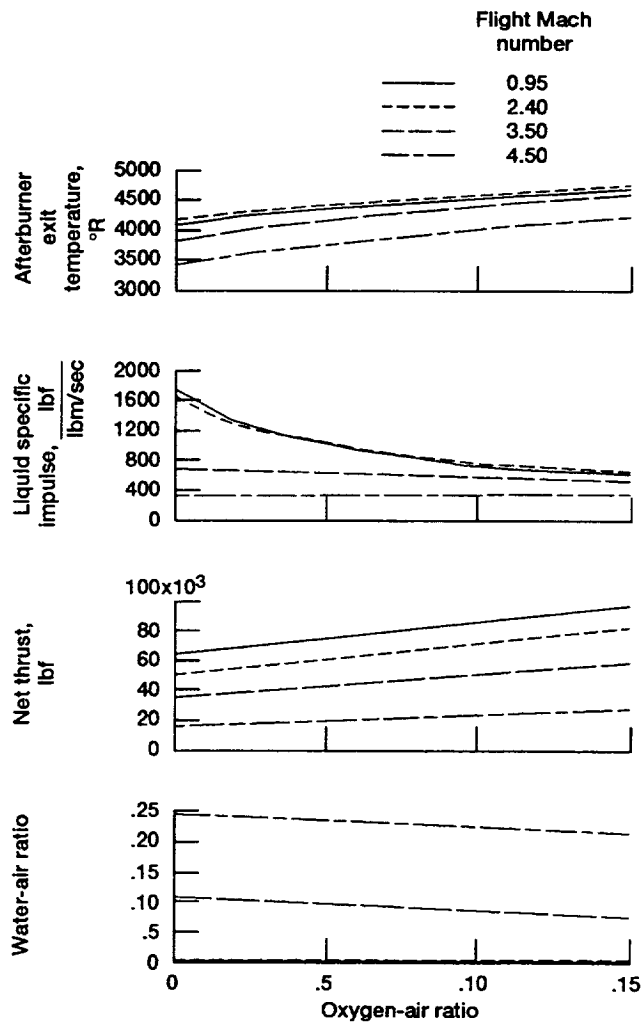

Figure 6.—Effect of oxygen injection on performance of mixed-flow turbofan engine. Normal altitude schedule.



# REPORT DOCUMENTATION PAGE

Form Approved  
OMB No. 0704-0188

Public reporting burden for this collection of information is estimated to average 1 hour per response, including the time for reviewing instructions, searching existing data sources, gathering and maintaining the data needed, and completing and reviewing the collection of information. Send comments regarding this burden estimate or any other aspect of this collection of information, including suggestions for reducing this burden, to Washington Headquarters Services, Directorate for Information Operations and Reports, 1215 Jefferson Davis Highway, Suite 1204, Arlington, VA 22202-4302, and to the Office of Management and Budget, Paperwork Reduction Project (0704-0188), Washington, DC 20503.

<b>1. AGENCY USE ONLY (Leave blank)</b>		<b>2. REPORT DATE</b> July 1993	<b>3. REPORT TYPE AND DATES COVERED</b> Technical Memorandum	
<b>4. TITLE AND SUBTITLE</b> Analysis of Gas Turbine Engines Using Water and Oxygen Injection to Achieve High Mach Numbers and High Thrust			<b>5. FUNDING NUMBERS</b>  WU-505-70-00	
<b>6. AUTHOR(S)</b>  Hugh M. Henneberry and Christopher A. Snyder				
<b>7. PERFORMING ORGANIZATION NAME(S) AND ADDRESS(ES)</b>  National Aeronautics and Space Administration Lewis Research Center Cleveland, Ohio 44135-3191			<b>8. PERFORMING ORGANIZATION REPORT NUMBER</b>  E-7998	
<b>9. SPONSORING/MONITORING AGENCY NAME(S) AND ADDRESS(ES)</b>  National Aeronautics and Space Administration Washington, D.C. 20546-0001			<b>10. SPONSORING/MONITORING AGENCY REPORT NUMBER</b>  NASA TM-106270	
<b>11. SUPPLEMENTARY NOTES</b>  Hugh M. Henneberry, Analex Corporation, 3001 Aerospace Parkway, Brook Park, Ohio 44142; and Christopher A. Snyder, NASA Lewis Research Center. Responsible person, Christopher A. Snyder, (216) 977-7018.				
<b>12a. DISTRIBUTION/AVAILABILITY STATEMENT</b>  Unclassified - Unlimited Subject Category 07			<b>12b. DISTRIBUTION CODE</b>	
<b>13. ABSTRACT (Maximum 200 words)</b>  This report describes an analysis of gas turbine engines using water and oxygen injection to enhance performance by increasing Mach number capability and by increasing thrust. The liquids are injected, either separately or together, into the subsonic diffuser ahead of the engine compressor. A turbojet engine and a mixed-flow turbofan engine (MFTF) are examined, and in pursuit of maximum thrust, both engines are fitted with afterburners. The results indicate that water injection alone can extend the performance envelope of both engine types by one and one-half Mach numbers at which point water-air ratios reach 17 or 18 percent and liquid specific impulse is reduced to some 390 to 470 seconds, a level about equal to the impulse of a high energy rocket engine. The envelope can be further extended, but only with increasing sacrifices in liquid specific impulse. Oxygen-airflow ratios as high as 15 percent were investigated for increasing thrust. Using 15 percent oxygen in combination with water injection at high supersonic Mach numbers resulted in thrust augmentation as high as 76 percent without any significant decrease in liquid specific impulse. The stoichiometric afterburner exit temperature increased with increasing oxygen flow, reaching 4822 °R in the turbojet engine at a Mach number of 3.5. At the transonic Mach number of 0.95 where no water injection is needed, an oxygen-air ratio of 15 percent increased thrust by some 55 percent in both engines, along with a decrease in liquid specific impulse of 62 percent. Afterburner temperature was approximately 4700 °R at this high thrust condition. Water and/or oxygen injection are simple and straightforward strategies to improve engine performance and they will add little to engine weight. However, if large Mach number and thrust increases are required, liquid flows become significant, so that operation at these conditions will necessarily be of short duration.				
<b>14. SUBJECT TERMS</b>  Turbomachinery; Air-breathing engines; Gas turbine engines; Water injection			<b>15. NUMBER OF PAGES</b> 20	
			<b>16. PRICE CODE</b> A03	
<b>17. SECURITY CLASSIFICATION OF REPORT</b> Unclassified	<b>18. SECURITY CLASSIFICATION OF THIS PAGE</b> Unclassified	<b>19. SECURITY CLASSIFICATION OF ABSTRACT</b> Unclassified	<b>20. LIMITATION OF ABSTRACT</b>	