

Spring 6-30-1981

Analysis of oscillations in nonlinear systems using multiple input describing functions

Frederic Lee Swern
New Jersey Institute of Technology

Follow this and additional works at: <https://digitalcommons.njit.edu/dissertations>



Part of the [Electrical and Electronics Commons](#)

Recommended Citation

Swern, Frederic Lee, "Analysis of oscillations in nonlinear systems using multiple input describing functions" (1981). *Dissertations*. 1262.

<https://digitalcommons.njit.edu/dissertations/1262>

This Dissertation is brought to you for free and open access by the Electronic Theses and Dissertations at Digital Commons @ NJIT. It has been accepted for inclusion in Dissertations by an authorized administrator of Digital Commons @ NJIT. For more information, please contact digitalcommons@njit.edu.

Copyright Warning & Restrictions

The copyright law of the United States (Title 17, United States Code) governs the making of photocopies or other reproductions of copyrighted material.

Under certain conditions specified in the law, libraries and archives are authorized to furnish a photocopy or other reproduction. One of these specified conditions is that the photocopy or reproduction is not to be “used for any purpose other than private study, scholarship, or research.” If a user makes a request for, or later uses, a photocopy or reproduction for purposes in excess of “fair use” that user may be liable for copyright infringement,

This institution reserves the right to refuse to accept a copying order if, in its judgment, fulfillment of the order would involve violation of copyright law.

Please Note: The author retains the copyright while the New Jersey Institute of Technology reserves the right to distribute this thesis or dissertation

Printing note: If you do not wish to print this page, then select “Pages from: first page # to: last page #” on the print dialog screen

The Van Houten library has removed some of the personal information and all signatures from the approval page and biographical sketches of theses and dissertations in order to protect the identity of NJIT graduates and faculty.

INFORMATION TO USERS

This was produced from a copy of a document sent to us for microfilming. While the most advanced technological means to photograph and reproduce this document have been used, the quality is heavily dependent upon the quality of the material submitted.

The following explanation of techniques is provided to help you understand markings or notations which may appear on this reproduction.

1. The sign or "target" for pages apparently lacking from the document photographed is "Missing Page(s)". If it was possible to obtain the missing page(s) or section, they are spliced into the film along with adjacent pages. This may have necessitated cutting through an image and duplicating adjacent pages to assure you of complete continuity.
2. When an image on the film is obliterated with a round black mark it is an indication that the film inspector noticed either blurred copy because of movement during exposure, or duplicate copy. Unless we meant to delete copyrighted materials that should not have been filmed, you will find a good image of the page in the adjacent frame. If copyrighted materials were deleted you will find a target note listing the pages in the adjacent frame.
3. When a map, drawing or chart, etc., is part of the material being photographed the photographer has followed a definite method in "sectioning" the material. It is customary to begin filming at the upper left hand corner of a large sheet and to continue from left to right in equal sections with small overlaps. If necessary, sectioning is continued again—beginning below the first row and continuing on until complete.
4. For any illustrations that cannot be reproduced satisfactorily by xerography, photographic prints can be purchased at additional cost and tipped into your xerographic copy. Requests can be made to our Dissertations Customer Services Department.
5. Some pages in any document may have indistinct print. In all cases we have filmed the best available copy.

University
Microfilms
International

300 N. ZEEB RD., ANN ARBOR, MI 48106

8121971

SWERN, FREDERIC LEE

ANALYSIS OF OSCILLATIONS IN NONLINEAR SYSTEMS USING
MULTIPLE INPUT DESCRIBING FUNCTIONS

New Jersey Institute of Technology

D.ENG.SC.

1981

University
Microfilms
International

300 N. Zeeb Road, Ann Arbor, MI 48106

PLEASE NOTE:

In all cases this material has been filmed in the best possible way from the available copy.
Problems encountered with this document have been identified here with a check mark .

1. Glossy photographs or pages _____
2. Colored illustrations, paper or print _____
3. Photographs with dark background _____
4. Illustrations are poor copy _____
5. Pages with black marks, not original copy _____
6. Print shows through as there is text on both sides of page _____
7. Indistinct, broken or small print on several pages _____
8. Print exceeds margin requirements _____
9. Tightly bound copy with print lost in spine _____
10. Computer printout pages with indistinct print
11. Page(s) _____ lacking when material received, and not available from school or author.
12. Page(s) _____ seem to be missing in numbering only as text follows.
13. Two pages numbered _____. Text follows.
14. Curling and wrinkled pages _____
15. Other _____

ANALYSIS OF OSCILLATIONS IN NONLINEAR
SYSTEMS USING
MULTIPLE INPUT DESCRIBING FUNCTIONS

by
Frederic Lee Swern

This dissertation is to be used only with due regard to the rights of the author. Bibliographical references may be noted, but passages must not be copied without permission of the Institute and without credit being given in subsequent written or published word.

Dissertation submitted to the Faculty of the Graduate School
of the New Jersey Institute of Technology in partial fulfillment
of the requirements for the degree of
Doctor of Engineering Science
1981

APPROVAL SHEET

Title of Thesis: Analysis of Oscillations in Nonlinear Systems Using
Multiple Input Describing Functions

Name of Candidate: Frederic L. Swern
Doctor of Engineering Science, 1981

Thesis and Abstract Approved:

Dr. A. U. Meyer
Professor
Electrical Engineering

Dr. D. Blackmore
Associate Professor
Mathematics

Date Approved:

VITA

Name: Frederic Lee Swern

Degree and date to be conferred: D. Eng. Sc., 1981

Secondary education: Francis Lewis High School, Fresh Meadows, New York, 1964.

Collegiate institutions attended	Dates	Degree	Date of Degree
City College of New York	9/64-1/69	BEE	1/69
Newark College of Engineering	9/71-6/74	MEE	6/74
New Jersey Institute of Technology	9/74-6/81	D. Eng. Sc.	6/81

Major: Electrical Engineering

Positions Held:

1978 - 1981	Senior Engineer, Bendix Flight Systems Division Teterboro, New Jersey.
1973 - 1978	Senior Systems Programmer, Chubb & Son, Short Hills, New Jersey.
1969 - 1972	Engineer, Bendix Navigation and Control, Teterboro, New Jersey.

ABSTRACT

Title of Thesis: Analysis of Oscillations in Nonlinear Systems Using Multiple Input Describing Functions

Frederic L. Swern, Doctor of Engineering Science, 1981

Thesis Directed by: Dr. A. U. Meyer, Professor of Electrical Engineering
Dr. D. Blackmore, Associate Professor of Mathematics

Sufficient conditions for oscillation as well as absence of oscillations are presented for a class of systems containing one lumped linear element and a differentiable nonlinearity. The results are obtained by estimating the error inherent in using a describing function analysis. Contraction type arguments are used to show common topological properties of the describing function solution and the balance of first harmonic terms of the system.

After discussing the describing function method, two theorems are presented regarding existence or nonexistence of oscillations from homotopic considerations. A graphical method for examining systems with power law nonlinearities is given using a parameter plane of frequency and amplitude. As an example, the method is applied to the Van der Pol oscillator when the linear element is sufficiently low pass. An analytical method is derived that is particularly easy to apply in the design of power law oscillators.

It is shown that multiple input describing functions may be used in some cases for which the describing function method is inconclusive. The results obtained in estimating the amplitude and frequency of oscillation using dual input describing functions are compared to their single input counterparts for a number of examples.

The class of nonlinearities for which the methods may be applied includes polynomial functions. It is shown that one can also apply similar techniques to systems containing jump discontinuities when the nonlinear element can be approximated arbitrarily closely by a continuous function. One can say that such a function is almost continuous. An ideal relay, a relay with deadzone and a staircase function are analyzed in this manner. In some systems, improved results are obtained by representing the nonlinearity as the sum of a bounded almost continuous function and a polynomial.

All of the methods developed have been computerized. Numerous examples are presented to illustrate the application of the methods.

ACKNOWLEDGEMENTS

The author would like to express his gratitude to Professor Andrew U. Meyer for his support and guidance throughout his years of graduate study. The technical advice provided by Dr. Denis Blackmore of the Mathematics Department was invaluable in completing this research. Both men spent many hours with the author, and their work is greatly appreciated.

The author wishes to thank his colleagues at Bendix Flight Systems Division for their encouragement during this undertaking. The support of Messrs. Kurt Moses, Jerry Doniger, and Al Kirchhein is gratefully acknowledged.

Finally, the patience and understanding of the author's wife, Gayle, and children, Lauren and Michael, is greatly appreciated for without it, this work could never have been undertaken.

TABLE OF CONTENTS

Chapter	Page
ACKNOWLEDGEMENTS.	ii
I. INTRODUCTION	1
II. REVIEW OF THE STATE OF THE ART	5
A. Stability Theory	5
B. Mathematical Background.	16
C. Current Work on Oscillation Theory	24
III. DEFINITION OF THE PROBLEM.	35
A. System Description	35
B. Describing Functions	38
C. Topological Analysis	39
IV. GRAPHICAL METHODS FOR POWER LAW SYSTEMS.	47
V. ANALYTICAL METHODS FOR POWER LAW SYSTEMS	63
VI. EXPANDING THE RESULTS.	74
A. Multiple Input Describing Functions.	74
B. More General Nonlinearities.	78
VII. SYSTEMS CONTAINING APPROXIMATELY DISCONTINUOUS NONLINEAR FUNCTIONS.	91
VIII. CONCLUSIONS.	121
REFERENCES.	124

LIST OF FIGURES

Figure		Page
2-1	Direct Control System.	13
3-1	Nonlinear Feedback System.	36
4-1	Conditions for Solution of $F(2\sigma/\lambda)$	56
4-2	Proof of Oscillation by Theorem III $n(x) = 1/3x^3$, $G(s) = .05s/(s^2 - .05s + 1)$	58
4-3	Proof of Oscillation by Theorem III $n(x) = 1/3x^3$, $G(s) = (s - 1)/(s^4 + s^3 - 12s - 12)$	59
4-4	Proof of Oscillation by Theorem III $n(x) = 1/3x^3$, $G(s) = .09s^2/(s^4 - .6s^3 + 1.81s^2 - .6s + 1)$	60
4-5	Proof of Oscillation by Theorem III $n(x) = .1x^5$, $G(s) = .02s/(s^2 - .02s + 1)$	61
4-6	Proof of Oscillation by Theorem III $n(x) = 1/35x^7$, $G(s) = .0075s/(s^2 - .0075s + 1)$	62
5-1	Relation Between Ω and Ω'	65
5-2	Finding the Value of c_2	69
5-3	Table of Parameters vs. P.	70
5-4	A Plot of the Region Surrounding the DF Solution when $n(x) = 1/3x^3$, $G(s) = .03s/(s^2 - .03s + 1)$	73
6-1	Proof of Oscillation by Theorem V $n(x) = 1/3x^3$, $G(s) = .05s/(s^2 - .05s + 1)$	79
6-2	Proof of Oscillation by Theorem V $n(x) = 1/3x^3$, $G(s) = .1s/(s^2 - .1s + 1)$	80
6-3	Proof of Oscillation by Theorem V $n(x) = 1/3x^3$, $G(s) = (s - 1)/(s^4 + s^3 - 12s^2 - 12)$	81
6-4	Proof of Oscillation by Theorem V $n(x) = 1/3x^3$, $G(s) = .09s^2/(s^4 - .6s^3 + 1.91s^2 - .6s + 1)$	82

LIST OF FIGURES (CONT'D)

FIGURE		PAGE
6-5	A Comparison of Ω for $n(x) = 1/3x^3$ when Computed by DF Method (Theorem III) and DIDF Method (Theorem V).	83
6-6	Transforming Systems to have a Minimum Slope of Zero .	87
6-7	Proof of Oscillation by Theorem VI $n(x) = .00571x^7 + .02x^5 + .2x^3$; $G(s) = (s - 1)/(s^4 + s^3 - 160s^2 - 160)$	90
7-1	Ideal Relay.	92
7-2	Limiter with High Gain	93
7-3	Relay with Deadzone.	94
7-4	Staircase Function	95
7-5	Proof of Oscillation by Theorem VIII Ideal Relay, $A = 1.57$, $G(s) = (s - 1)/(s^4 + s^3)$	106
7-6	Proof of Oscillation by Theorem VIII Relay with Deadzone, $A = 1.62$, $B = .5$, $G(s) = (s - 1)/(s^4 + s^3)$	107
7-7	Proof of Oscillation by Theorem VIII Staircase Function, $A_1 = .75$, $A_2 = 1.25$, $A_3 = 1.6378$, $B_1 = 0$, $B_2 = .5$, $B_3 = 1.0$, $G(s) = (s - 1)/(s^4 + s^3)$	108
7-8	Proof of Oscillation by Corollary VIII $G(s) = s^2/(s^4 - .25s^3 + s^2 - .25s + 1)$	111
7-9	Nonlinearity Under Consideration	114
7-10	Equivalent Control System.	116
7-11	Proof of Oscillation by Theorem IX $n(x) = u(t - 1) - u(1 - t) - .149x^3$, $G(s) = (s - 1)/(s^4 + s^3 - .05^2 - 10)$	120

CHAPTER I

INTRODUCTION

In the field of automatic control, the study of system behavior under a variety of initial conditions is often crucial to successful design. One seeks to build a stable system; in a practical sense, this may mean that under all conditions of operation, the system is free of self-oscillations. Conversely, when one designs an oscillator, this may mean all conditions lead to a self-oscillation.

When a system is linear, the problem has been completely solved by such techniques as nyquist plots and root locus. However, nonlinear systems exhibit phenomena that are entirely absent from their linear counterparts. To begin with, these systems can have drastically different behavior at different points in state space; when the basic form of the solution changes, this is called bifurcation. Moreover, one is rarely able to find a solution for such a system in closed form.

One of the most popular methods of dealing with nonlinear systems is describing function (DF) analysis, an easy to apply method that gives approximate information. Some degree of intuition must be used to decide whether or not a system will oscillate.

Mathematicians have developed topological and functional analysis techniques for examining the qualitative properties of solutions to a nonlinear differential equation. In certain cases these methods may be applied to answer the question of whether or not a solution of a specific form exists, but it may tell little about the numerical values associated with it. The techniques to be used include fixed point theorems and topological degree.

The goal of this study is to obtain conditions under which the oscillatory properties of a system may be rigorously ascertained. In addition, when a limit cycle exists, it is desired to estimate a region in some suitable parameter space, as small as possible, that contains the oscillation. As a basis for the analysis, describing functions will be used.

Some work has already been done toward substantiating the describing function method analytically [10, 15-19, 45, 51]. In particular, the work of Mees and Bergen [93] provides conditions for oscillation in cases when the slope of the nonlinearity is bounded. Most other results to date deal with systems containing a bounded nonlinearity, or a nonlinearity with bounded derivative.

The present work deals with systems containing a differentiable nonlinearity, but its derivative is not necessarily bounded. A Van der Pol oscillator is an example of a system of this type. In addition, certain discontinuities in the derivative of a nonlinearity will be allowed so that systems that are "almost" discontinuous in a sense to be described later may be examined. Multiple input describing functions will be used to improve the results.

The application of the new methods may result in expressions that are difficult to evaluate by hand. It was always intended that a digital computer would be used to translate the problem into a form useful for analysis or design. Many of the results can be presented graphically in some parameter space, so that the user might be better able to interpret them.

Chapter II gives a review of the current state of the art. In Section A relevant mathematical terminology, including that involving state space, periodic solutions and describing functions, are covered along with other pertinent concepts from classical stability theory. Section B covers more mathematical background necessary including the concepts of metric spaces, Banach spaces, fixed points and areas of functional analysis. A review of recent work done in oscillation theory is given in Section C.

Chapter III contains a detailed description of the problem. In Section A the system to be studied is defined. Describing functions are rigorously defined in Section B. Section C contains two basic theorems that will be used throughout the work to analyze the existence or nonexistence of oscillations from homotopic considerations. All three subsections define notation used in the remaining sections.

A graphical method for examining systems for power law nonlinearities is given in Chapter IV. It is shown that, if the linear element is sufficiently low pass, the technique will yield useful results. Illustrative examples are included.

Chapter V gives an analytic method which, while more conservative than the method of the previous chapter, is very easy to apply. It appears to be useful in designing oscillators.

The basic results are expanded in Chapter VI. A theorem is presented in Section A for proving oscillations with multiple input describing functions. Results obtained with dual input describing

functions are compared to their single input counterparts. Section B deals with extending the results to nonlinearities that may be represented by polynomials.

Some systems with jump discontinuities can be approximated by continuous systems. The analysis of these systems is covered in Chapter VII. It is shown that an ideal relay, a relay with deadzone, and a staircase function can all be analyzed using the methods outlined in Chapter III. Some of the techniques are applied to nonlinearities which are the sum of a staircase function and a polynomial.

Chapter VIII is the final chapter and contains some conclusions based upon the work done and recommendations for future study.

CHAPTER II

REVIEW OF THE STATE OF THE ART

A. Stability Theory

Attention is focused upon a system that is autonomous and time-invariant. Let the state of the system be defined as a set of numbers that uniquely represents the condition of the system at a given instant. Then a Euclidean n -space X which represents the change in state with time is called a state space. If the co-ordinates of X are represented by x_1, x_2, \dots, x_n , then the system may often be represented by the set of n first order differential equations

$$\frac{dx_i}{dt} = f_i(x_1, x_2, \dots, x_n); \quad i = 1, 2, \dots, n \quad (2-1)$$

which is equivalent to the vector differential equation

$$\dot{\underline{x}} = - \underline{f}(\underline{x}). \quad (2-2)$$

Consider a point \underline{x}_0 in state space. The function $\underline{f}(\underline{x})$ is said to satisfy a Lipschitz condition at $\underline{x} = \underline{x}_0$ if there exists positive numbers α and β such that

$$\| \underline{f}(\underline{x}) - \underline{f}(\underline{x}_0) \| \leq \alpha \| \underline{x} - \underline{x}_0 \| \quad (2-3)$$

provided that $\| \underline{x} - \underline{x}_0 \| < \beta$. Let a solution of (2-2) passing through \underline{x}_0 at $t = 0$ be denoted by $\underline{x} = \xi(\underline{x}_0, t)$. It can be shown [100], [107] that a sufficient condition for the existence of a unique solution is that $\underline{f}(\underline{x})$ satisfy a Lipschitz condition about \underline{x}_0 .

When the solution $\underline{x} = \xi(\underline{x}_0, t)$ is plotted in n-dimensional space, it is called a trajectory. If the entire trajectory passing through a point consists of the point itself, then the point is a singular point of the differential equation and an equilibrium point of the system. Singular points are solutions of the equation

$$\underline{f}(\underline{x}_e) = \underline{0}. \quad (2-4)$$

The concept of stability of a singular point was rigorously formulated by the Russian mathematician A. M. Lyapunov shortly before the turn of the century [69]. Singular points are either stable, if all trajectories in a neighborhood of the point stay within a neighborhood of the point, or unstable if some trajectories starting within any neighborhood of a point leave this neighborhood. More precisely, for stability, if δ and ϵ are positive numbers, where δ depends on ϵ , then

$$\|\underline{x}_0 - \underline{x}_e\| \leq \delta \rightarrow \|\xi(t, \underline{x}_0) - \underline{x}_e\| \leq \epsilon, \forall t > 0 \quad (2-5)$$

If, in addition to being stable, the trajectories within a neighborhood of a singular point converge to that point as $t \rightarrow \infty$, then the point is asymptotically stable. The stability of a singular point can be ascertained from perturbation analysis (Lyapunov's first method) by examining the eigenvalues of the system

$$\delta \dot{\underline{x}} = \left. \frac{\partial \underline{f}(\underline{x})}{\partial \underline{x}} \right|_{\underline{x} = \underline{x}_e} \delta \underline{x} \quad (2-6)$$

and using standard linear analysis techniques.

While perturbation analysis is sufficient to examine the stability of a point, it is not sufficient to show global stability of a system or even stability in some large region of operation. In these cases Lyapunov's second (or direct) method may be applied. The appeal of this method lies in the fact that the system trajectory need not be known explicitly to apply it.

Consider a system whose total energy function is known. If it can be shown that, in some region (possibly global), the energy is always decreasing with time, then the motion of the system must tend toward a single equilibrium state contained in the region. Lyapunov generalized this concept to substitute for the energy of the system a scalar function $V(\underline{x})$ that is continuous and has continuous derivatives and in addition, within some region,

$$V(\underline{0}) = 0; V(\underline{x}) > 0, \forall \underline{x} \neq \underline{0}. \quad (2-7)$$

Mathematically, such a function is termed positive definite in the region. The equilibrium state is stable within the region if, in addition,

$$\dot{V}(\underline{0}) = 0; \dot{V}(\underline{x}) \leq 0, \forall \underline{x} \neq \underline{0} \quad (2-8)$$

or the time derivative of V is negative semi-definite. A function $V(\underline{x})$ that satisfies the continuity conditions and (2-7), (2-8) is called a Lyapunov function. By translating the state plane so that the equilibrium state of the system is at the origin, this approach may be used to examine the stability of an arbitrary system.

The main drawback to the approach is that there is no general method of determining the existence of Lyapunov functions for arbitrary systems. However, when such functions can be found, it is the most general method of stability analysis available [107].

Let the system motion start at some arbitrary point in state space; then, for a system of engineering interest, there are four possibilities for the resulting trajectory. It can tend toward a singular point, it can tend toward infinity, it can tend toward a closed trajectory, or it can itself be a closed trajectory. The last case represents curves which, like singular points, are steady state solutions of the system. If all trajectories in the vicinity of a closed curve trajectory (other than the closed trajectory) of a system are not themselves closed curves, then the closed curve is called a limit cycle.

If a system admits a periodic solution, then, for any \underline{x}_0 on this solution and all t ,

$$\xi(t, \underline{x}_0) = \xi(t - \tau, \underline{x}_0) \quad (2-9)$$

(where $\tau > 0$ is the period) and hence the trajectory in state space is closed. It is possible for such a system to be conservative (i.e., the total energy of the system remains constant, as in an LC circuit) and the motion is represented by an infinite number of closed curves in the phase plane. However, most of the systems to be studied do not have the conservative property and their periodic solutions can be represented in the phase plane as limit cycles.

The definition of stability and instability in the sense of Lyapunov can be extended from singular points to limit cycles. When the trajectory

starts slightly perturbed from the limit cycle, it may stay in some neighborhood of it, or not. In the former case, one has a stable limit cycle, and in the latter case an unstable one. Note also that a limit cycle may be semi-stable; stable if approached from one direction in the state plane and unstable if approached from another. If a periodic solution is known for a system, then its stability can be checked by perturbation analysis.

Work on the existence or non-existence of limit cycles has yielded a reasonably general theory only in the case of second order systems. Such systems are easier to analyze because of their geometric simplicity in state space. A theorem of Poincaré and Bendixson states that, in the state plane of a second order system, if a trajectory remains inside a finite region and does not approach a singular point, it must approach a limit cycle or itself be periodic [69].

A theorem by Bendixson gives a sufficient condition for nonexistence of limit cycles in planar (second order) differential equations. Let the system be described by

$$\dot{x}_1 = f_1(x_1, x_2), \quad \dot{x}_2 = f_2(x_1, x_2). \quad (2-10)$$

If, for some region, $\partial f_1/\partial x_1 + \partial f_2/\partial x_2$ does not change sign, then no limit cycle can exist within that region [174].

Another method due to Poincaré for showing oscillations in a planar differential equation is the use of 'successor functions'. Successor functions are mappings of the intersection of a trajectory and some fixed transverse hyperplane into the next intersection of the trajectory

with the same hyperplane. As an example, let it be assumed that a second order system has a solution dependent on a parameter, λ , and, when $\lambda = 0$, the solution is a circle in the phase plane.

If the motion starts at some point r_0 , where r is a distance measured along a particular arc, then the distance between successive intersections of the arc and the trajectory is denoted as ψ . For the trajectory to be periodic,

$$\psi(r_0, \lambda) = r(\tau, r_0, \lambda) - r(0, r_0, \lambda) = 0. \quad (2-11)$$

That is, at the end of one complete cycle the trajectory should return to its starting point. By expanding ψ as a power series in the parameters r_0, λ one can find periodicity equations by direct substitution. The main difficulty with the method is that solving for coefficients of the power series is only possible in very simple cases [100].

While the Poincaré-Bendixon theorem can only be used to show limit cycles in the planar case, the principle of the torus may be used to topologically demonstrate limit cycles in n dimensional state space. Let there be defined a toroidal region in state space, which contains no equilibrium state, such that all trajectories pass through the boundaries of the torus and remain inside as time increases. It is possible to take a cross sectional slice of the torus that is perpendicular to the assumed direction of the closed trajectory, call it S . If it can be shown that all trajectories passing through S at some time, say t_0 , move around the torus in such a manner as to intersect S at time $t_0 + \tau$ and further S is homeomorphic to a ball of dimension $(n - 1)$, then (by Brouwer's fixed point theorem) there exists a trajectory that closes upon itself, or a periodic solution [121].

One of the most popular engineering methods for examining periodic motion is the describing function method. A solution of the form (2-9) can be represented by a fourier series

$$x(t) = \sum_{k=1}^{\infty} a_k \cos \left(\frac{2\pi kt}{\tau} + \theta_k \right) \quad (2-12)$$

where a_k and θ_k are constants that depend on the system structure and x_0 . In this case x is a scalar that represents only one component of the state vector. It is assumed that (2-12) may be approximated by

$$x(t) = a \cos \left(\frac{2\pi t}{\tau} \right). \quad (2-13)$$

This is substituted into the differential equation of the system and the constants a and τ are computed. It is assumed that the frequency response of the linear elements of the system is such that the higher harmonics generated by the nonlinearity are sufficiently attenuated and may be neglected. Then the 'equivalent gain' of a nonlinear element to a sinusoidal signal of frequency $\omega = 2\pi/\tau$ is computed as a function of the amplitude a . This is substituted in the differential equation of the system and the resulting equations solved.

As an example, if a system contains one nonlinear element represented by $n(x)$ and one linear element represented by $G(s)$, then the describing function $N(a)$ for the nonlinearity is

$$N(a) = \frac{1}{\pi a} \int_0^{2\pi} e^{-j\theta} n(a \cos\theta) d\theta. \quad (2-14)$$

The describing function method states that if the equation

$$[G(j\hat{\omega}) N(\hat{a}) + 1] \hat{a} = 0 \quad (2-15)$$

has a solution $(\hat{\omega}, \hat{a})$ then the system 'probably' has a limit cycle close in frequency and amplitude to $(\hat{\omega}, \hat{a})$. Conversely, if no solution exists other than $\hat{a} = 0$, the system 'probably' has no limit cycle oscillations [69].

It is possible to consider two or more harmonically related frequencies when using the describing function method. A two harmonic or dual input describing function uses two complex equations of the form (2-15) to solve for fourier coefficients both at the fundamental and higher harmonic frequencies [69].

A system capable of sustaining limit cycle behavior may have different self-excitation properties. If all trajectories (except for the singular points) lead to a stable limit cycle, the system is said to exhibit soft self-oscillation. However, if only trajectories within a certain region of state space lead to a stable limit cycle, then the system exhibits hard self-oscillation. The minimum value of initial conditions (when the initial conditions may be stated as some displacement of the system) is termed the threshold value [100].

The domain of attraction of a singular point is also of interest because, if it can be shown to be global, then no limit cycles can exist. The absolute stability problem was proposed by Lur'e and Postnikov for studying autonomous systems. They studied a system that is linear except for a single nonlinear element $n(x)$ which is restricted by the inequality

$$xn(x) > 0. \quad (2-16)$$

Such a system is shown in Figure 2-1, and is sometimes called a 'direct' control system to distinguish it from other configurations studied later

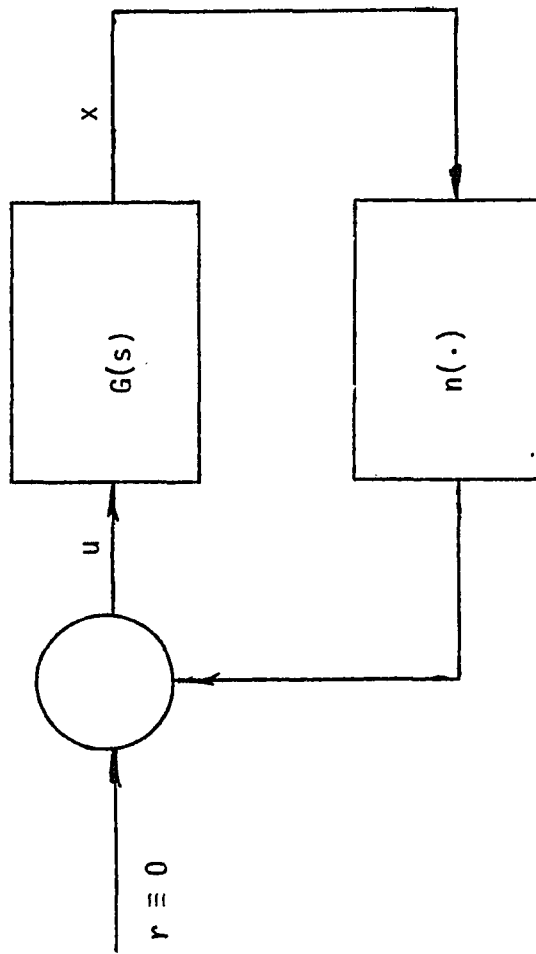

FIGURE 2-1 DIRECT CONTROL SYSTEM

by Lasalle, Lefschetz and Popov [69]. Lur'e proposed finding constraints on the linear element, $G(s)$, such that the system would be stable for any nonlinear element $n(x)$ [107].

A significant contribution of Lur'e and Postnikov is the introduction of the candidate Lyapunov function

$$V(\underline{x}) = 1/2 \underline{x}^T P \underline{x} + \beta \int_0^y f(\zeta) d\zeta \quad (2-17)$$

where P is a symmetric positive definite matrix and β is a scalar.

The Rumanian mathematician V. M. Popov introduced frequency domain criteria that could be applied to problems of the Lur'e type. These criteria provide sufficient conditions for asymptotic stability of control systems of the form of Figure 2-1. The original work of Popov was improved upon by Desoer [41] and others so that the following generalized theorem has evolved.

Let the nonlinear element be restricted to lie in the sector $[0, k]$; that is

$$0 \leq \frac{n(x)}{x} \leq k. \quad (2-18)$$

Further if the linear element is output stable (i.e., the impulse response of $G(s)$ is both absolute and square integrable and the initial condition response is square integrable for every set of initial conditions) and if a real number q exists and some small $\delta > 0$ such that

$$\text{Re} [(1 + j\omega q) G(j\omega)] + \frac{1}{k} \geq \delta > 0. \quad (2-19)$$

Then the system is "absolutely control and output asymptotic" (i.e., $\int_0^{\infty} x^2(t) dt < \infty$ and $\int_0^{\infty} n(t) dt < \infty$ for every set of initial conditions) subject to the following conditions on the real number q :

1) if $n(x)$ is single valued and time invariant:

$$\text{if } 0 < k < \infty, \text{ then } -\infty < q < \infty$$

$$\text{if } k = \infty, \text{ then } 0 < q < \infty$$

2) if $n(x)$ contains passive hysteresis:

$$0 < k < \infty \text{ and } -\infty < q \leq 0$$

3) if $n(x)$ contains active hysteresis:

$$0 < k \leq \infty \text{ and } 0 < q < \infty$$

4) if $n(x)$ is a general nonlinearity:

$$0 < k \leq \infty \text{ and } q = 0$$

Passive and active hysteresis may be defined in terms of the path directions taken (counter clockwise or clockwise) when the nonlinearity is subjected to a periodic input and its output plotted [122, 123, 69].

Inequality (2-19) may be interpreted in terms of a nyquist plot of $G(s)$. Then, for stability when $q = 0$, $G(j\omega)$ must stay to the right of a line parallel to the imaginary axis intersecting the real axis at $-1/k$. It is harder to work graphically with the nyquist plot when $q \neq 0$; however (2-19) may be rewritten as

$$\text{Re } G(j\omega) > -\frac{1}{k} + \omega q \text{ Im } G(j\omega). \quad (2-20)$$

Now the locus of points of the function $G^*(j\omega) = \text{Re } G(j\omega) + j\omega \text{ Im } G(j\omega)$ may be plotted in the complex plane and (2-20) states that Popov's theorem is satisfied if this locus is to the right of a line passing through the point $\text{Re } G(j\omega) = -1/k$ and making an angle of $\tan^{-1} q$ with the vertical axis [69].

From this theorem, other theorems have been derived; for example, a theorem applicable for nonlinearities limited by $a \leq n(x)/x \leq b$. A simple extension of this theorem applied for "degree of stability" in the sense of limitation of the response by an exponential $Me^{-\alpha t}$ [69].

B. Mathematical Background

The output of a system often belongs to the set of real numbers, \mathbb{R} . If y is a vector of dimension two, then elements of y are represented by ordered pairs (y_1, y_2) and belong to the product set $\mathbb{R} \times \mathbb{R}$, or \mathbb{R}^2 . And so on with higher dimensional vectors.

A metric space consists of some nonempty set X and a metric d . The metric represents a generalized notion of distance between two points, and is a single-valued, non-negative, real function satisfying the following three conditions for arbitrary $x, y, z \in X$: -

- 1) $d(x,y) = 0$ if and only if $x = y$
- 2) $d(x,y) = d(y,x)$ (axiom of symmetry)
- 3) $d(x,y) + d(y,z) \geq d(x,z)$ (triangle inequality)

Note that for a given set X the metric is not unique; different metrics may be associated with the same set yielding different metric spaces.

The notion of convergence of an infinite sequence can be defined in terms of a metric. Consider the sequence $\{x_n\} = \{x_1, x_2, \dots\}$ which converges to the point x , if, for any $\epsilon > 0$, there exists an $n(\epsilon)$ such that $n > n(\epsilon)$ implies that $d(x, x_n) < \epsilon$. In many cases the limit point x is not known; however, the relation between any two elements in some cases be shown to satisfy $d(x_m, x_n) < \epsilon$ for all $n, m \geq n(\epsilon)$. The latter relationship is called a Cauchy criterion, but it is not true that all

sequences satisfying the Cauchy criterion are convergent. A metric space in which every Cauchy sequence is convergent is called a complete space.

A set of elements A is said to form a linear space if the operations of addition and scalar multiplication are defined and satisfy the following conditions.

I) For any $x, y \in A$, there is a uniquely defined $z = x + y$ called their sum, $z \in A$, such that

$$1) \quad x + y = y + x$$

$$2) \quad x + (y + z) = (x + y) + z$$

$$3) \quad \text{There exists an element } 0 \in A \text{ such that } x + 0 = x \text{ for all } x \in A$$

$$4) \quad \text{For every } x \in A, \text{ there is an element } -x \in A \text{ such that } x + (-x) = 0.$$

II) For some arbitrary number α and an element $x \in A$ there is defined an element αx (the product of α and x) such that

$$1) \quad \alpha(\beta x) = (\alpha\beta)x$$

$$2) \quad 1 \cdot x = x$$

III) Addition and multiplication are related in the following manner

$$1) \quad (\alpha + \beta)x = \alpha x + \beta x$$

$$2) \quad \alpha(x + y) = \alpha x + \alpha y \quad \forall y \in A$$

Note that a linear space may also be a metric space. A linear space X is said to be a normed linear space if each element $x \in X$ there is a corresponding nonnegative number $\|x\|$, called its norm, satisfying the following conditions

- 1) $||x|| = 0$ if and only if $x = 0$
- 2) $||\alpha x|| = |\alpha| ||x||$
- 3) $||x + y|| \leq ||x|| + ||y||$ (triangle inequality)

A normed linear space that is also complete is called a Banach space.

The spaces \mathbb{R} and \mathbb{C} (complex plane) are Banach spaces.

Consider two arbitrary nonempty sets X and Y . If, for each element $x \in X$ there is a unique corresponding element $y \in Y$, denoted by $f(x)$, then f is a mapping of X into Y . f may also be called a function or transformation or operator. X is called the domain of f and Y is called the range of f ; if the range of f is only a subset of Y then f is said to map X into Y . A point y is called the image of x under the mapping f if $f(x) = y$; in this case one also says x belongs to the inverse image of y denoted by $x \in f^{-1}(y)$.

When X and Y are metric spaces, then, if a sequence $\{x_n\}$ converges to the point x implies that $\{f(x_n)\}$ converges to $y = f(x)$, the mapping f is continuous. If a mapping f is one-to-one and both f and f^{-1} are continuous, then f is called a homeomorphism.

As a matter of notation, when writing functions, the parenthesis will be omitted when no confusion results. Thus $f(x)$ is written fx . Two functions may succeed each other as in $g(f(x))$ which will be written gfx . This is called a composition.

A function is said to be linear if

$$f(\alpha_1 x_1 + \alpha_2 x_2) = \alpha_1 f(x_1) + \alpha_2 f(x_2) \quad (2-21)$$

where α_1 and α_2 are scalars. The norm of a linear function f on a normed linear space can be defined by

$$\|f\| = \sup_{\|x\| \leq 1} \|fx\| = \sup_{\|x\| = 1} \|fx\| = \sup_{x \neq 0} \frac{\|fx\|}{\|x\|}. \quad (2-22)$$

Any element that satisfies the equation $x = F(x)$ where $x \in X$ is called a fixed point of the mapping F . A mapping may have more than one fixed point. If F is defined on a metric space (X, d) , then it is said to be a contraction if there exists a number $\alpha < 1$ such that

$$d(Fx, Fy) \leq \alpha d(x, y) \quad (2-23)$$

for any two points $x, y \in X$. Every contraction mapping is continuous.

Theorem (contraction mapping theorem). Every contraction mapping defined in a complete metric space X has one and only one fixed point [77].

If x_0 is any point in X and x^* is the fixed point, then

$$x^* = \lim_{n \rightarrow \infty} F^n(x_0), \text{ where } F^n = \underbrace{F F F \dots F}_n \quad (2-24)$$

and further

$$d(x^*, x_0) \leq \frac{d(x_1, x_0)}{1 - \alpha} \quad (2-25)$$

where $x_1 = F(x_0)$. If the derivative of the mapping exists, it may be used to show contraction by the following theorem

Theorem (derivative of contracting mapping). Let F map a closed convex subset Ω of a Banach space into itself and have a derivative at every point of Ω . Then if

$$\sup_{x \in \Omega} ||F'(x)|| = \alpha < 1 \quad (2-26)$$

there exists a unique fixed point of F in Ω [68].

Now let $x = -f(x)$ be a real valued differentiable function with $\alpha \leq f'(x) \leq \beta$ for all x . Then, if c is any number $\neq -1$,

$$x = -[f(x) - cx] - cx = -(1 + c)^{-1} [f(x) - cx] = m(x) \quad (2-27)$$

and the condition for the mapping $x = m(x)$ (which has the same fixed points as $x = f(x)$) to be a contraction is

$$|m'(x)| \leq |1 - c|^{-1} \max \{|\beta - c|, |c - \alpha|\} < 1. \quad (2-28)$$

It may be seen that if $\alpha > -1$ the minimum value of (2-28) occurs at $c = 1/2 (\alpha + \beta)$ in which case

$$|1 + c|^{-1} \max \{|\beta - c|, |c - \alpha|\} = \frac{\beta - \alpha}{2 + \beta + \alpha} < 1. \quad (2-29)$$

Let $1 \leq p < \infty$. L_p space is defined as the space of all real-valued measurable functions f for which

$$\int_{-\infty}^{\infty} |f(t)|^p dt < \infty \quad (2-30)$$

(where integration is in the sense of Lebesgue). It is a Banach space [68] with norm

$$|f|_p = \left(\int_{-\infty}^{\infty} |f(t)|^p dt \right)^{1/p}. \quad (2-31)$$

A periodic function is one which satisfies $x(t) = x(t + \tau)$, $\forall t$, where τ is the period of the function. Such a function may be represented in L_2 space by the fourier series

$$x(t) = \sum_{k=1}^{\infty} a_k \cos(k\omega_0 t + \theta_k) \quad (2-32)$$

where $\omega_0 = 2\pi/\tau$ is the fundamental frequency. An L_p space of periodic functions may be defined where integrability takes place over one period so that

$$\int_0^{\tau} |f(t)|^p dt < \infty. \quad (2-33)$$

A linear space is called an inner product space if, for any $x, y \in X$ there is a number, called the inner product $\langle x, y \rangle$, such that

- 1) $\langle y, x \rangle = \langle x, y \rangle^*$ (* denotes complex conjugation)
- 2) $\langle \lambda x_1 + \mu x_2, y \rangle = \lambda \langle x_1, y \rangle + \mu \langle x_2, y \rangle$
- 3) $\langle x, x \rangle \geq 0$ and $\langle x, x \rangle = 0$ if and only if $x = 0$.

A complete inner product space is called a Hilbert space. Two elements (x, y) of a Hilbert space are said to be orthogonal if $\langle x, y \rangle = 0$.

The set of real-valued periodic functions of period T which are square integrable form a Hilbert space with inner product

$$\langle x, y \rangle = \frac{1}{T} \int_0^T x(t) y(t) dt. \quad (2-34)$$

A complete orthogonal set consists of sines and cosines which can be represented in the usual way in terms of cosines of the form $\cos k\omega t$, $k = 1, \dots, \infty$. Then one may define a projection operator so that

$$P^1 x(t) = a \cos \omega t \quad (2-35)$$

and so on. Finally, the L_2 norm may be expressed in terms of the fourier coefficients using Parseval's identity

$$\|x\|^2 = \frac{1}{2\pi} \int_0^{2\pi} x^2(\theta) d\theta = \sum_{k=1}^{\infty} |a_k|^2. \quad (2-36)$$

Let S be the closure of an open set in $\mathbb{R}^n = \{x = (x_1, \dots, x_n) : x_i \in \mathbb{R}, 1 \leq i \leq n\}$. Define a continuous vector field $\underline{\phi}$ on S as the map

$$\underline{\phi}: S \rightarrow \mathbb{R}^n \quad (2-37)$$

$$\text{where } \underline{\phi} = (\phi_1, \dots, \phi_n) \quad (2-38)$$

and each ϕ_i is continuous on S . It is assumed that $\underline{\phi}$ is differentiable, as every continuous function can be approximated by a polynomial. A point \underline{x}_0 is a singular point of $\underline{\phi}$ if $\underline{\phi}(\underline{x}_0) = \underline{0}$. Further, \underline{x}_0 is isolated if there are no other singular point in

$$|\underline{x} - \underline{x}_0| < \varepsilon$$

for some $\varepsilon > 0$. A point $\underline{y} \in \mathbb{R}^n$ is said to be a regular value of $\underline{\phi}$ if, for all \underline{x} such that $\underline{\phi}(\underline{x}) = \underline{y}$, the Jacobian determinant

$$J \left(\frac{\underline{\phi}}{\underline{x}} \right)_{\underline{x}} \equiv \det \left(\frac{\partial \phi_i}{\partial x_j} \right)_{\underline{x}} \neq 0. \quad (2-39)$$

If \underline{y} is a regular value, there are only finitely many \underline{x} such that $\underline{\phi}(\underline{x}) = \underline{y}$, or

$$\underline{x}_1, \dots, \underline{x}_m \in \underline{\phi}^{-1}(\underline{y}). \quad (2-40)$$

A singular point \underline{x}_0 is termed nondegenerate if the Jacobian determinant of $\underline{\phi}$ evaluated at \underline{x}_0 is nonzero. If \underline{x}_0 is an isolated singular point,

there exists \underline{y} arbitrarily close to $\underline{0}$ such that \underline{y} is a regular value of ϕ . The index of ϕ at \underline{x}_0 is defined as

$$I_{\underline{x}_0}(\phi) = \lim_{\substack{\underline{y} \text{ regular,} \\ \underline{y} \rightarrow \underline{0}}} \sum_{\underline{x} \in \phi^{-1}(\underline{y})} \text{sgn } J\left(\frac{\phi}{\underline{x}}\right) \quad (2-41)$$

$$\text{where } \text{sgn}(x) = \begin{cases} +1 & x > 0 \\ -1 & x < 0 \end{cases} .$$

Now suppose that ϕ has only isolated singular points, $\underline{x}_1, \dots, \underline{x}_m$ in S . The index of ϕ on S is defined as

$$I_S(\phi) = \sum_{i=1}^m I_{\underline{x}_i}(\phi). \quad (2-42)$$

If ϕ is merely continuous on S , having singular points which may not all be isolated, then given $\epsilon > 0$ there exists a differentiable vector field ϕ_ϵ on S having only isolated singular points and satisfying

$$|\phi - \phi_\epsilon| \text{ sup on } S < \epsilon.$$

The index of ϕ on S is defined as

$$I_S(\phi) = \lim_{\epsilon \rightarrow 0} I_S(\phi_\epsilon). \quad (2-43)$$

Let ϕ be a vector field on $S \subset \mathbb{R}^n$ and $\Omega \subset S$ be such that $\phi \neq 0$ on S . Let ψ be another vector field on Ω such that $\psi \neq 0$ on S . A homotopy \underline{F} from ϕ to ψ is a continuous function $\underline{F}(\underline{x}, t)$, $0 \leq t \leq 1$, such that $\underline{F}(\underline{x}, 0) = \phi(\underline{x})$ and $\underline{F}(\underline{x}, 1) = \psi(\underline{x})$ for $\forall \underline{x} \in \Omega$, and $\underline{F}(\underline{x}, t) \neq 0$, $0 \leq t \leq 1$, $\underline{x} \in S$. If such a homotopy exists, ϕ and ψ are termed homotopic on S .

Theorem (basic homotopy lemma). Let Ω be any set homeomorphic to the disc $\sum_{k=1}^n x_k^2 \leq 1$. Let ϕ and ψ be continuous vector fields on Ω , neither of which vanish on $\partial\Omega$. Then if ϕ and ψ are homotopic on $\partial\Omega$, it follows that $I_{\Omega}(\phi) = I_{\Omega}(\psi)$. [36]

It is said that the vector function $\psi(\underline{x})$ is a principal part of $\phi(\underline{x})$ if $\phi(\underline{x})$ can be written as

$$\phi(\underline{x}) = \psi(\underline{x}) + \omega(\underline{x}) \quad (2-44)$$

where ω is a function such that, along the boundary of some region

$$||\omega(\underline{x})|| < ||\psi(\underline{x})||. \quad (2-45)$$

Theorem (Rouché). A vector field is homotopic to its principal part [80].

C. Current Work on Oscillation Theory

Most of the recent work in stability theory of nonlinear systems concerns the development of frequency domain relations to guarantee absolute stability. The introduction of the Popov criterion stimulated interest in obtaining less conservative estimates of stability regions of the system by taking into account characteristics of the nonlinearity. Two techniques are generally used in proving stability criteria.

In the first method, a Lyapunov function is found for the system, generally of the Lur'e-Postnikov form. This may be related to frequency domain criteria using a form of the Kalman-Yakubovich Lemma.

A transfer function $G(s)$ is defined as positive real if $G(\sigma)$ is real when σ is real and $\operatorname{Re} G(s) > 0$ for all $\operatorname{Re} s > 0$. Brockett and Willems [21, 22] expand on the Popov criterion by showing absolute stability of a system if a positive real function exists of the form

$$H(s) = Z(s) (G(s) + 1/k) \quad (2-46)$$

where $G(s)$ = Transfer function of the linear part of the system

k = Maximum gain of the nonlinearity

$Z(s)$ = Multiplier whose form depends on the nonlinear element

where, for the Popov criterion, $Z(s) = (1 + \alpha s)^{-1}$.

If the nonlinearity, denoted n , belongs to the class of functions limited only to the first quadrant, i.e. $0 < xn(x) < \infty$, then one writes $n \in A_k$ and the Popov criterion appears to be the least conservative stability estimate. If, in addition, n is monotonic, $0 < dn/dx < \infty$, $n(0) = 0$, n^{-1} exists, then one writes $n \in M_k$ and $Z(s)$ may take on values

$$Z(s) = a_0 s + \sum_{i=1}^n a_i (s + z_i) / (c_i s + z_i); c_i \leq 1. \quad (2-47)$$

Equation (2-47) represents the most general driving point impedance which can be constructed from inductors and resistors.

Further, if the nonlinearity is odd monotonic, one writes $n \in O_k$, then $Z(s)$ can take on values given by (2-47) except $c_i \leq 2$. When n can be expressed as a power law, then

$$n(x) = k |x|^\mu \operatorname{sgn}(x). \quad (2-48)$$

This is denoted by $n \in P_k$ and the multiplier $Z(s)$ can be obtained from (2-47) except $c_i \leq \phi(\mu)$ where $\phi(\mu) > 2$ and approaches 2 as $\mu \rightarrow 0$.

The proofs of the above criteria are based on Lyapunov functions translated to frequency domain relations. Other authors with a similar approach include O'Shea [118, 119], Dewey [44], Thathachar and Srinath [160], Thathachar, Srinath, and Ramapriyan [159], Thathachar [161], and Narendra and Neuman [105].

The second technique involves functional analysis, as exemplified by Zames [189, 190]. The analysis is done in the extended L_2 space which contains functions that, when truncated to exist over some finite time interval, belong to the L_2 space. When the complete function does not have an L_2 norm, its extended L_2 norm is defined as infinity.

After defining gain and incremental gain as $g(G) = \sup (||Gx||/||x||)$ and $\tilde{g}(G) = \sup (||Gx - Gy||/||x - y||)$ respectively, a simple theorem states that, if the open loop gain of a system is less than one the system motion is bounded, and if the open loop incremental gain of a system is less than one, the system is input-output stable. The concepts of conicity (restriction of a function to a sector of an input-output graph), positivity (function lies only in the first and third quadrant) and similar incremental quantities are introduced. These are used to prove a circle condition similar to the Popov condition. If the nonlinearity is contained in the sector $\{\alpha, \beta\}$ and the linear function is $G(j\omega)$ then the circle conditions are satisfied if there exists a $\delta > 0$ and the following hold:

$$1) \text{ If } \alpha > 0, |G(j\omega) + 1/2(1/\alpha + 1/\beta)| \geq 1/2(1/\alpha - 1/\beta) + \delta, \\ \omega \in (-\infty, \infty) \quad (2-49)$$

and the nyquist diagram of $H(j\omega)$ does not encircle $-1/2(1/\alpha - 1/\beta)$

$$2) \text{ If } \alpha < 0, |G(j\omega) + 1/2 (1/\alpha + 1/\beta)| \leq 1/2 (1/\alpha - 1/\beta) - \delta \quad (2-50)$$

$$3) \text{ If } \alpha = 0, \operatorname{Re} \{G(j\omega)\} \geq - (1/\beta) + \delta, \omega \in (-\infty, \infty).$$

If the circle criterion holds (incrementally), then the system is L_2 bounded (L_2 - continuous).

Other authors proving stability inequalities using functional analysis are Narendra and Cho [106], Towle and Kazda [163], Sundaresham and Thathachar [156], Cho and Narendra [31], and Zames and Falb [191].

Noldus [111, 112, 114] deals with finding the existence of oscillations using the torus principle. The torus Noldus chooses consists of an n -dimensional ellipsoid intersecting a cone whose vertex is at the origin. The origin is omitted from the torus. By using the Kalman-Yakubovich Lemma, he proved that the trajectory will remain within the torus if

- 1) There exists real scalars K_1, K_2, K_3, K_4 and a function $h(u)$ such that $|n(u) - h(u)|$ is bounded for all u and

$$K_1 u^2 \leq uh(u) \leq K_2 u^2 \quad (2-51)$$

$$K_3 u^2 \leq un(u) \leq K_4 u^2 \quad (2-52)$$

- 2) $(1 + K_2 G(s))/(1 + K_1 G(s))$ is strictly positive real, where $G(s)$ is the transfer function of the linear portion.
- 3) The linearized equivalent system has at the origin n characteristic values in the right half s plane.

4) For some scalar function r

$$\operatorname{Re} \left\{ \frac{1 + K_4 G(j\omega - r)}{1 + K_3 G(j\omega - r)} \right\} > 0, \forall \omega \in \mathbb{R} \quad (2-53)$$

With some additional conditions on the numerator of the transfer function, the Brouwer fixed point theorem is used to prove the existence of an oscillation.

Williamson [175] sets out to define conditions for proving oscillations using the torus principle and the notion of 1-forms. A 1-form is defined by

$$\zeta(x) = \sum_{j=1}^n g_j(x) dx_j \triangleq \langle g(x), dx \rangle. \quad (2-54)$$

A 1-form is termed exact if it represents the derivative of some function, i.e. $\zeta(x) = df(x)$. If the system is described by

$$\dot{x} = G(x) \quad x(0) = x_0, \quad x \in \mathbb{R}^n \quad (2-55)$$

then G carries a closed nonexact 1-form if

$$\langle g(x), G(x) \rangle \geq \epsilon > 0, \forall x, \quad (2-56)$$

i.e. $(dg(x)/dx) (dx/dt) \geq \epsilon > 0$ while the rate of travel along some trajectory is positive. By applying Poincaré's method of successor functions, then a function called a continuous one parameter semigroup can be shown to intersect some surface of section repeatedly. If this surface of section is a Brouwer set, (2-55) has a nontrivial periodic oscillation.

Fitts [47], in a study of systems that violate the Aizerman conjecture, documents a class of systems that are fourth order, oscillate,

but have no describing function solution. They do, however, have a dual input describing function solution. Also given are some third order nonlinear systems that exhibit this characteristic.

Garber [51] examines the problem of determining the error inherent in using the describing function method (when applied to nonautonomous systems) by considering the impulse response of the linear portion of the system defined as

$$R(t - \tau) = -\frac{\omega}{\pi} \left\{ \frac{G(0)}{2} + \sum_{k=1}^{\infty} \text{Re } G(jk\omega) \cos k(t - \tau) - \text{Im } G(jk\omega) \sin k(t - \tau) \right\}. \quad (2-57)$$

He shows if a Lipschitz constant for the nonlinearity $f(z)$ is equal to M , a bound on the DF error is

$$|z - \hat{z}| \leq \frac{\max \left| \int_0^{2\pi/\omega} (R - \hat{R}) f(\hat{z}) d\tau \right| + \max |\psi - \hat{\psi}|}{1 - M \int_0^{2\pi/\omega} |R| d\tau}. \quad (2-58)$$

Note that ψ is the input to the system, \hat{z} , \hat{R} , $\hat{\psi}$ are terms of the DF solution, and the auxiliary condition

$$\int_0^{2\pi/\omega} |R| d\tau < 1 \quad (2-59)$$

must be satisfied. By using a similar approach, Garber and Rozenvasser [52] show that, for autonomous systems, when the equation of the higher order harmonics is given by

$$x_h(t) = \int_0^{T/2} \phi_h(t - \tau) f(x(\tau)) d\tau. \quad (2-60)$$

The error, Δ , due to higher order harmonics is given by

$$\Delta \leq N\epsilon(\omega); \quad |f(x)| \leq N \quad (2-61a)$$

$$\Delta \leq \frac{AM_0\epsilon(\omega)}{1 - M_0\epsilon(\omega)}; \quad |f(x)| \leq M_0|x| \quad (2-61b)$$

$$\Delta \leq \frac{M_1 A \omega \epsilon^*(\omega)}{1 - M_1 \epsilon(\omega)}; \quad |f'(x)| \leq M_1 = \text{const} \quad (2-61c)$$

where $\epsilon(\omega) = \int_0^{T/2} |\phi_h(u)| du$; $\phi_h(u) = \frac{\omega}{\pi} \sum_{k=-\infty}^{\infty} G[(2k+1)j\omega] e^{(2k+1)j\omega u}$

$$\epsilon^*(\omega) = \int_0^{T/2} \left| \frac{1}{\pi} \sum_{k=-\infty}^{\infty} \frac{G[(2k+1)j\omega]}{(2k+1)j} e^{(2k+1)j\omega u} \right| du \quad (2-62)$$

Using these values, the following error bands may be plotted in the complex plane to give the describing function error as

$$\left| \frac{1}{G(j\omega)} - N(A) \right| \leq \frac{4M_1\Delta}{\pi A}. \quad (2-63)$$

Bergen and Franks [10] study the problem using functional analysis in an L_2 space. They show that if the following conditions are satisfied:

- 1) $G(j\omega) \rightarrow 0$ as $\omega \rightarrow \infty$
- 2) n, G have continuous derivatives

- 3) $dn/dx \neq 0, x = \hat{x}$
- 4) $dG/d\omega \neq 0, \omega = \hat{\omega}$
- 5) The G and $-1/n$ locus are not tangent at $(\hat{x}, \hat{\omega})$

and, if $||n|| < \infty$

- 6) $||n|| \leq M$
- 7) $\rho_\omega = M \max \{|G(j\omega k)|; K = 3, 5, \dots\} < 1$

or, if the norm of n is not bounded,

- 8) there exists a number M' , $||nx - ny|| \leq M' ||x - y||_\infty$
- 9) $k|G(j\omega k)| \rightarrow 0$ as $k \rightarrow \infty$
- 10) $\rho'_\omega = (M'\pi/\sqrt{8}) \max \{k|G(j\omega k)|; k = 3, 5, \dots\} < 1$,

and furthermore, there exists an open, bounded, set Ω such that

- 1) $(\hat{\omega}, \hat{a}) \in \Omega$
- 2) for $\forall(\omega, a) \in \partial\Omega$

$$B(\omega) T(a) < \left| \frac{1}{N(a)} + G(j\omega) \right| \quad (2-64)$$

where

$$T(a) \triangleq \left(\frac{||n(a \sin \theta)||^2}{|a N(a)|^2} - 1 \right)^{1/2} \quad (2-65)$$

$$B(\omega) = \begin{cases} \frac{|G(j\omega)| \rho_\omega}{1 - \rho_\omega} & \text{if } ||n|| < \infty \\ |G(j\omega)| \rho'_\omega & \text{otherwise,} \end{cases} \quad (2-66)$$

then there exists an oscillation with $(\omega, a) \in \Omega$.

Mees and Bergen [93] expand on the above work by considering the DF solution to be an approximation to the exact solution

$$[G(j\omega) N(a) + 1] a = E(\omega, a). \quad (2-67)$$

If the term $E(\omega, a)$ can be bounded, then the existence or nonexistence of oscillations can be analyzed. If it is assumed that the nonlinearity satisfies the slope conditions

$$\alpha(x_1 - x_2) \leq (nx_1 - nx_2) \leq \beta(x_1 - x_2) \quad (2-68)$$

for all x_2, x_1 with $x_2 > x_1$, then it follows that

$$|E(\omega, a)| \leq |G(j\omega)| \frac{\beta - \alpha}{2} \frac{\lambda(\omega)}{1 - \lambda(\omega)} a$$

where

$$\lambda(\omega) = \sup_{\substack{k > 1 \\ k \text{ odd}}} \left| \frac{G(jk\omega)}{1 + \frac{\beta + \alpha}{2} G(jk\omega)} \right| \frac{\beta - \alpha}{2} < 1. \quad (2-69)$$

These equations have a simple geometric interpretation which allows error bands to be drawn around the DF locus. When the error bands completely intersect the real axis, the Leray-Schauder theorem is used to prove the existence of an oscillation.

In a series of papers on harmonic balance justification, Braverman et al [17, 18 19] derive a set of error expressions for a DF solution in the time domain. When the nonlinear function satisfies a Lipschitz condition with constant β , and an M harmonic DF solution, they find

$$|x(t) - \hat{x}(t)| \leq \varepsilon^{1/2} R \phi_\alpha(\hat{\omega}), t \in [t_0, t_0 + S \ln(1/\varepsilon^{1/2})] \quad (2-70)$$

where

$$\varepsilon = \max(\varepsilon_1, \varepsilon_2, \varepsilon_3),$$

$$\varepsilon_i = \frac{\int_{|\omega| > (M + \alpha)\hat{\omega}} |d^i/d\omega^i G(j\omega)| d\omega}{\int_{|\omega| \leq (M + \alpha)\hat{\omega}} |d^i/d\omega^i G(j\omega)| d\omega}, \quad (i = 0, 1, 2) \quad (2-71)$$

$$\alpha \in (0, 1)$$

$$R = \left[\max_k \beta \sum_{k=1}^M |a_k| \int_{-\infty}^{\infty} \left[|G(j\omega)| + 2 \left| \frac{dG(j\omega)}{d\omega} \right| + \left| \frac{d^2 G(j\omega)}{d\omega^2} \right| \right] d\omega \right] \quad (2-72)$$

$$S = \left(\beta \int_{-\infty}^{\infty} |G(j\omega)| d\omega \right)^{-1} \quad (2-73)$$

$$\phi_\alpha(\omega) = \max \left\{ \frac{2}{(1 - \alpha)\omega}, \frac{7}{(1 - \alpha)^2 \omega^2}, 1 \right\} \quad (2-74)$$

A similar theorem is given for the bounds on the DF solutions in a relay system, with relay limit parameter A , and single harmonic DF solution,

namely

$$0 \leq t \leq \left[\frac{\ln(1/\varepsilon^{1/2})}{2 \ln[R(1 + \phi)]} - 1 \right] \frac{\pi}{\hat{\omega}}, \quad |x(t) - \hat{x}(t)| \leq \varepsilon^{1/2} \\ \leq \min \left\{ \frac{\sqrt{3}}{2} a, \frac{a\hat{\omega}\theta}{2} \right\} \quad (2-75)$$

where

$$\varepsilon = \max \{ \varepsilon_0, \varepsilon_1, \varepsilon_2 \}, \quad \varepsilon_i = \frac{\int_{|\omega| > 2\hat{\omega}} |d^i/d\omega^i G(j\omega)| d\omega}{\int_{|\omega| \leq 2\hat{\omega}} |d^i/d\omega^i G(j\omega)| d\omega}, \quad (i = 0, 1, 2)$$

$$(2-76)$$

$$R = A \max \left\{ \frac{2}{\hat{\omega}}, \frac{6}{\hat{\omega}^2}, 1 \right\} \int_{-\infty}^{\infty} \left[|G(j\omega)| + 2 \left| \frac{dG(j\omega)}{d\omega} \right| + \left| \frac{d^2G(j\omega)}{d\omega^2} \right| \right] d\omega \quad (2-77)$$

$$\phi = 1 + \frac{4A}{a\hat{\omega}} \int_{\infty}^{\infty} |G(j\omega)| d\omega. \quad (2-78)$$

CHAPTER III
STATEMENT OF THE PROBLEM

A. System Description

The system S is an autonomous feedback configuration of the Lur'e-Postnikov type, and is shown in Figure 3-1. It is assumed the only equilibrium state occurs at $\underline{x} = \underline{0}$. The nonlinear element has no memory, has bounded derivative on any closed bounded set, and has odd symmetry. It is assumed that g satisfies the condition

$$\sup_{0 < m < \infty} |m G(j\omega m)| < \infty, \forall \omega > 0. \quad (3-1)$$

As an example of the type of system being considered, the linear element g can be represented by the state equations

$$\begin{aligned} \dot{\underline{x}} &= A\underline{x} + B\underline{u} \\ y &= C^T \underline{x} \end{aligned} \quad (3-2)$$

where A , B , C are suitably defined matrices. Further, (3-2) must be completely controllable and completely observable; that is, given an arbitrary initial condition (\underline{x}_0, t_0) and an arbitrary final condition (\underline{x}_f, t_f) , it is possible to find a control function $u(t)$ to take the system from (\underline{x}_0, t_0) to (\underline{x}_f, t_f) (provided $t_f > t_0$). Also, given the output $y(t)$ and the input $u(t)$ it is possible to construct the state history, $\underline{x}(t)$. From (3-2) then it is possible to represent the transfer function of g as

$$G(s) = c(sI - A)^{-1} B = \frac{p(s)}{q(s)}, \quad (3-3)$$

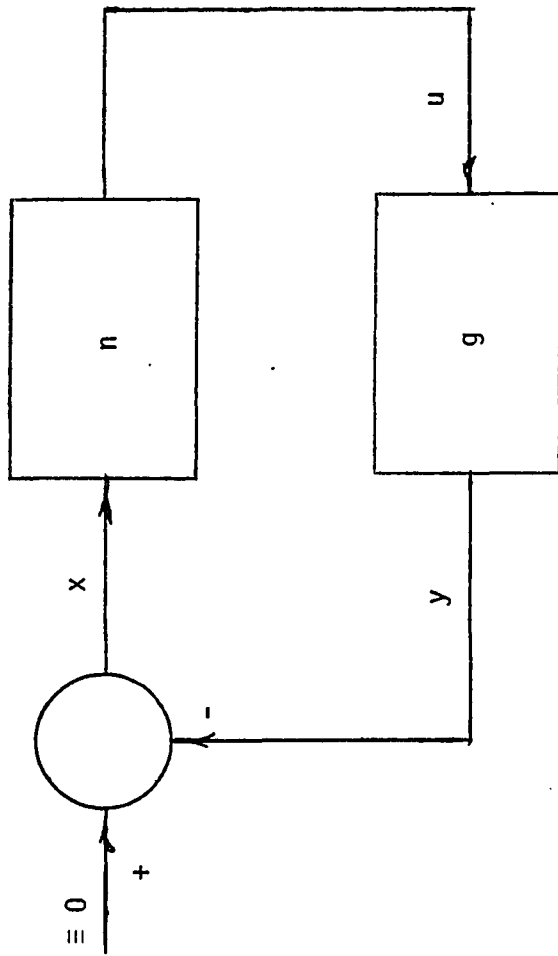

FIGURE 3-1 NONLINEAR FEEDBACK SYSTEM

where p and q are polynomials in s . From the form of (3-2) it is guaranteed that the degree of p exceeds that of q , and controllability and observability guarantee that p and q have no common factors.

The objective of the study is to investigate conditions under which the system will or will not oscillate. An oscillation is represented by a solution to the functional equation

$$x = -gnx \quad (3-4)$$

that is periodic; moreover it is assumed that such a solution is π -symmetric, so it can be written in the form

$$x = a \cos \omega t + \sum_{\substack{k=3 \\ k \text{ odd}}}^{\infty} a_k \cos(k\omega t + \theta_k). \quad (3-5)$$

It is convenient to represent this as $(\underline{a}, \underline{\theta})$ where

$$\begin{aligned} \underline{a} &= (a, a_3, \dots, a_{2n+1}, \dots) \\ \underline{\theta} &= (\theta_1, \theta_3, \dots, \theta_{2n+1}, \dots). \end{aligned} \quad (3-6)$$

It is also convenient to introduce x_m , where

$$x_m = a \cos \omega t + \sum_{\substack{k=3 \\ k \text{ odd}}}^m a_k \cos(k\omega t + \theta_k) \quad (3-7)$$

which may be represented by $(\underline{a}_m, \underline{\theta}_m)$, where

$$\begin{aligned} \underline{a}_m &= (a, a_3, \dots, a_m) \\ \underline{\theta}_m &= (\theta_1, \theta_3, \dots, \theta_m). \end{aligned} \quad (3-8)$$

B. Describing Function Approach

In the DF approach, the solution of (3-4) is assumed to be of the form

$$\hat{x}(t) = \sum_{k=1}^m \hat{a}_k \cos(k\hat{\omega}t + \hat{\theta}_k); \hat{\theta}_1 = 0. \quad (3-9)$$

Here the symbols \hat{x} , \hat{a}_k , $\hat{\omega}$, $\hat{\theta}_k$ are used to distinguish the DF solution from the actual solution, (3-5). When (3-9) is substituted in (3-4) one obtains, in transform notation,

$$[1 + G(jk\hat{\omega}) N_k(\hat{\underline{a}}, \hat{\underline{\theta}})] \hat{a}_k = 0, k = 1, \dots, m \quad (3-10)$$

where

$$\begin{aligned} \hat{\underline{a}} &= (\hat{a}_1, \hat{a}_3, \dots, \hat{a}_m) \\ \hat{\underline{\theta}} &= (\hat{\theta}_1, \hat{\theta}_3, \dots, \hat{\theta}_m). \end{aligned} \quad (3-11)$$

This represents $2m$ real simultaneous nonlinear equations in $2m$ unknowns: $\hat{\omega}$, \hat{a}_1 , \dots , \hat{a}_m , $\hat{\theta}_2$, \dots , $\hat{\theta}_m$. The quantity $N_k(\hat{\underline{a}}, \hat{\underline{\theta}})$ is the describing function of n and may be calculated from

$$N_k(\hat{\underline{a}}, \hat{\underline{\theta}}) = \frac{1}{\pi \hat{a}_k} \int_{\alpha}^{\alpha + 2\pi} n(\hat{x}(t)) \cos k\hat{\omega}t \, d\hat{\omega}t \quad (3-12)$$

where α is an arbitrary real number.

Usually, one takes $m = 1$, although it may be advantageous in certain cases to allow $m > 1$. When $m > 1$ the DF is called a multiple input describing function (MIDF). It is not true in general that all systems exhibiting oscillatory behavior have DF solutions when $m = 1$; this is related to Aizerman's conjecture and was disproved by counterexamples [47].

C. Topological Analysis

A π -symmetric, periodic, solution of (3-4) will be represented by

$$x(t) = \sum_{\substack{k=1 \\ k \text{ odd}}}^{\infty} a_k \cos(k\omega t + \theta_k) = \sum_{k=-\infty}^{\infty} A_k e^{jk\omega t} \quad (3-14)$$

where $a_k \in \mathbb{R}$, $A_k \in \mathbb{C}$, $A_{-k} = \bar{A}_k$, $A_1 \in \mathbb{R}$ and $\theta_1 = 0$. At times it will be convenient to make a change of variables so that $x = x(\phi)$ where $\phi = \omega t$ and ω corresponds to a particular solution. As a matter of notation, one may represent

$$|x|_s = \sup_{0 < \phi < 2\pi} |x(\phi)|. \quad (3-15)$$

Let X be the Hilbert space of real valued, periodic functions of period 2π . Two projection operators, P and P_* , may be defined so that

$$P^m x(t) = \sum_{k=1}^m a_k \cos(k\omega t + \theta_k) = x_m \quad (3-16)$$

$$P_*^m x(t) = \sum_{k=m+1}^{\infty} a_k \cos(k\omega t + \theta_k) = x - P^m x = x_*. \quad (3-17)$$

A space of this type leads naturally to the use of the L_2 norm, which will be defined as

$$(|x|_2)^2 = \frac{1}{2\pi} \int_0^{2\pi} x^2(\phi) d\phi = \sum_{\substack{k=1 \\ k \text{ odd}}}^{\infty} |a_k|^2. \quad (3-18)$$

Moreover, use will also be made of the $|| \cdot ||_1$ norm, which is defined as

$$|x|_1 = \sum_{k=1}^{\infty} |a_k|. \quad (3-19)$$

Since

$$\sum_{k=1}^{\infty} |a_k|^2 \leq \left(\sum_{k=1}^{\infty} |a_k| \right)^2 \quad (3-20)$$

it follows that boundedness of (3-19) implies boundedness of (3-18).

The converse, however, is not true in general. When $|x|_1 < \infty$, its relation to $|x|_s$ is

$$|x|_s = \left| \sum_{k=1}^{\infty} a_k \cos(k\phi + \theta_k) \right|_s \leq \sum_{k=1}^{\infty} |a_k| = |x|_1. \quad (3-21)$$

In the theorems that follow, when either norm is used, it will be represented by $|| \cdot ||$.

Both the DF solution and (3-14) will be shown to exist in some region Ω of a suitable parameter space. One chooses Ω so that it is homeomorphic to the disc $\sum_{k=1}^m x_k^2 = 1$. Henceforth, when the term disc is used, it will mean any region homeomorphic to a disc. It is further assumed that Ω is small enough to contain only one nontrivial DF solution.

When $m = 1$, the following theorem can be used to examine the validity of DF solutions: -

Theorem I: Consider a system S represented by $x = -gnx$ and let $-gn$ map points of X into itself. Suppose there exists a metric $d(x', x'')$, such that

$$d(P_*^1 g n x', P_*^1 g n x'') \leq \gamma d(x_*', x_*'')$$

$$\gamma < 1, \text{ for all } x', x'' \in X \quad (3-22)$$

holds whenever (a, ω) belongs to a disc Ω in the (a, ω) plane.

1) If there exist a DF solution $(\hat{a}, \hat{\omega}) \in \Omega$ and in addition

$$a) |1/G(j\omega) + N(a)| >$$

$$\frac{||P_*^1 g[n(a \cos \omega t + x_*) - n(a \cos \omega t)]||}{a} = \sigma \quad (3-23)$$

on $\partial\Omega$, where $x_* = x_*(a, \omega)$ is the unique fixed point of $-P_* g n x$ (it is easy to see that the same value results on the right side of (3-23) with either $| |_1$ or $| |_2$) and

$$b) \left| \frac{\partial N(a)}{\partial a} \right|_{a = \hat{a}} \neq 0 \quad \text{and}$$

$$c) -1/G(j\omega) \text{ is not parallel to } N(a) \text{ at } \omega = \hat{\omega}$$

then an oscillation exists with $(a, \omega) \in \Omega$.

2) If (3-22) and (3-23) are satisfied for $\forall (a, \omega) \in \Omega$, then no oscillation exists with $(a, \omega) \in \Omega$.

Proof: The orthogonality of the fourier series allows (3-4) to be separated into simultaneous equations of harmonic balance, i.e.

$$[a_k + \eta_k(\underline{a}, \underline{\omega}) G(jk\omega)] = 0, k = 1, \dots \quad (3-24)$$

where $\eta_k(\underline{a}, \underline{\omega})$ is the output of n at the k^{th} harmonic. The DF equation is related to the equation of first harmonic balance by

$$[a + \eta_1(\underline{a}, \underline{\theta}) G(j\omega)] = [1 + N(a) G(j\omega)] a + H(\underline{a}, \underline{\theta}, \omega) \quad (3-25)$$

where $H(\underline{a}, \underline{\theta}, \omega)$ is the error in using the DF.

Applying P_*^1 to (3-4), one obtains

$$x_* = - P_*^1 gn(x_1 + x_*) . \quad (3-26)$$

It follows from (3-22) that (3-26) has the contractive property in Ω ; hence x_* can be determined as a unique function of (a, ω) . Substituting this in (3-25) one obtains the following

$$[a + \eta_1(a, \omega) G(j\omega)] = [1 + N(a) G(j\omega)] a + H(a, \omega). \quad (3-27)$$

It may not be possible to calculate the function $H(a, \omega)$, but it is possible to find a bound. Apply P to (3-4) and see that

$$x_1 = - P^1 gn(x_1 + x_*). \quad (3-28)$$

Adding $P^1 gn x_1$ to both sides yields

$$x_1 + P^1 gn x_1 = P^1 g(n x_1 - n(x_1 + x_*)). \quad (3-29)$$

Taking norms on both sides, and converting to transform notation, one obtains (3-23) which is equivalent to

$$|1/G(j\omega) + N(a)| > \sigma(a, \omega) > \left| \frac{H(a, \omega)}{aG(j\omega)} \right|. \quad (3-30)$$

One may define vector fields

$$\phi(a, \omega) = [a + \eta_1(a) G(j\omega)] \quad (3-31)$$

$$\psi(a, \omega) = [1 + N(a) G(j\omega)] a. \quad (3-32)$$

From (3-30) and (3-31), $\psi(a, \omega)$ is the principal part of $\Phi(a, \omega)$ on $\partial\Omega$. Then $\Phi(a, \omega)$ and $\psi(a, \omega)$ are homotopically equivalent on $\partial\Omega$ and have identical indices by the basic homotopy lemma given in Chapter II. If the function $\psi(a, \omega)$ has only one singularity in Ω which is non-degenerate, then the index of ψ is nonzero. Since ψ is homotopic to Φ , Φ also has nonzero index and hence must have at least one zero in Ω . Under these conditions, a DF solution implies an oscillation of the system.

The DF has a non-degenerate singularity if its Jacobian evaluated at the singularity is nonzero. For the DF equation

$$J \left(\frac{\psi(a, \omega)}{a, \omega} \right)_{\substack{a = \hat{a} \\ \omega = \hat{\omega}}} = \hat{a} \begin{vmatrix} \operatorname{Re} \left[\frac{\partial N(a)}{\partial a} G(j\omega) \right] & \operatorname{Re} \left[N(a) \frac{\partial G(j\omega)}{\partial \omega} \right] \\ \operatorname{Im} \left[\frac{\partial N(a)}{\partial a} G(j\omega) \right] & \operatorname{Im} \left[N(a) \frac{\partial G(j\omega)}{\partial \omega} \right] \end{vmatrix}_{\substack{a = \hat{a} \\ \omega = \hat{\omega}}} \quad (3-33)$$

noting that use has been made of

$$[1 + N(\hat{a}) G(j\hat{\omega})] = 0. \quad (3-34)$$

When working with S , $N(a)$ is always real; hence $\operatorname{Im}(G(j\omega)) = 0$. Then (3-33) is nonzero if

$$\hat{a} \left(\operatorname{Re} \left[\frac{dN(a)}{da} \Big|_{a = \hat{a}} G(j\hat{\omega}) \right] \right) \left(\operatorname{Im} \left[N(\hat{a}) \frac{dG(j\omega)}{d\omega} \Big|_{\omega = \hat{\omega}} \right] \right) \neq 0. \quad (3-35)$$

Each term of (3-35) must be nonzero; $N(\hat{a})$ and $G(j\hat{\omega})$ are nonzero from (3-34). It is necessary to insure that

$$\left. \frac{dN(a)}{da} \right|_{a = \hat{a}} \neq 0 \quad (3-36)$$

$$\text{Im} \left. \frac{dG(j\omega)}{d\omega} \right|_{\omega = \hat{\omega}} \neq 0 \quad (3-37)$$

The last relation is equivalent to saying $-1/G(j\omega)$ is not parallel to $N(a)$ at $\omega = \hat{\omega}$. This proves condition 1 of the theorem. When (3-22) and (3-23) are satisfied at all point of Ω , then the (3-27) cannot have any solution with its right side equal to zero. Hence $a = 0$. Then $x_* = 0$ is an equilibrium solution of the system, and since (3-28) is a contractive mapping, it is the unique solution. Hence condition 2 of the theorem is proved. ■

The following result may be applied to examine the validity of MIDF solution: -

Theorem II: - Let S have a nontrivial MIDF solution.

Suppose x_* is contractively mapped into itself by (3-26) so that (3-22) holds (with P_*^m replacing P_*^1) over a disc Ω defined in the parametric space $(\underline{a}_m, \underline{\theta}_m, \omega)$. If, on $\partial\Omega$

$$\|(\underline{G}^{-1}(\omega) + \underline{N}(\underline{a}_m, \underline{\theta}_m)) \underline{a}_m\| > \|\underline{a}_m\| \sigma(\underline{a}_m, \underline{\theta}_m, \omega) \quad (3-38)$$

$$\sigma = \frac{\|P^m g[n(x_m + x_*) - n(x_m)]\|}{\|\underline{a}_m\|} \quad (3-39)$$

where in (3-38) the norm of a vector is defined as either

$$|\underline{a}_m|_1 = \sum_{k=1}^m |a_k| \quad (3-40)$$

$$|\underline{a}_m|_2 = \sqrt{\sum_{k=1}^m a_k^2} \quad (3-41)$$

corresponding to the norm used in (3-39), and

$$\underline{N}(\underline{a}, \underline{\theta}) = \text{diag} [N_1(\underline{a}, \underline{\theta}), \dots, N_m(\underline{a}, \underline{\theta})]$$

$$\underline{G}(\omega) = \text{diag} [G(j\omega), \dots, G(jm\omega)]$$

and

$$J \left(\frac{[1 + \underline{N}(\underline{a}_m, \underline{\theta}_m) \underline{G}(\omega)] \underline{a}_m}{\underline{a}_m, \underline{\theta}_m, \omega} \right) \neq 0. \quad (3-42)$$

$$\begin{aligned} \underline{a}_m &= \hat{\underline{a}} \\ \underline{\theta}_m &= \hat{\underline{\theta}} \\ \omega &= \hat{\omega} \end{aligned}$$

Then an oscillation exists with $(\underline{a}_m, \underline{\theta}_m, \omega) \in \Omega$.

Proof: When working with the MIDF, the equations of harmonic balance may be written in vector form

$$[\underline{a}_m + \underline{\eta}(\underline{a}, \underline{\theta}) \underline{G}(\omega)] = [I + \underline{N}(\underline{a}_m, \underline{\theta}_m) \underline{G}(\omega)] \underline{a}_m + \underline{H}(\underline{a}, \underline{\theta}, \omega) \quad (3-43)$$

where

$$\underline{\eta}(\underline{a}, \underline{\theta}) = [\eta_1(\underline{a}, \underline{\theta}), \dots, \eta_m(\underline{a}, \underline{\theta})]^T$$

$$\underline{H}(\underline{a}, \underline{\theta}, \omega) = [H_1(\underline{a}, \underline{\theta}, \omega), \dots, H_m(\underline{a}, \underline{\theta}, \omega)]^T$$

Again the higher order harmonics are uniquely determined from contraction mapping considerations, allowing (3-43) to be written as

$$[\underline{a}_m + \eta(\underline{a}_m, \underline{\theta}_m) \underline{G}(\omega)] = [I + \underline{N}(\underline{a}_m, \underline{\theta}_m) \underline{G}(\omega)] \underline{a}_m + \underline{H}(\underline{a}_m, \underline{\theta}_m, \omega). \quad (3-44)$$

Define two vector fields in $2m$ dimensions as

$$\Phi(\underline{a}_m, \underline{\theta}_m, \omega) = [\underline{a}_m + \eta(\underline{a}_m, \underline{\theta}_m) \underline{G}(\omega)] \quad (3-45)$$

$$\psi(\underline{a}_m, \underline{\theta}_m, \omega) = [I + \underline{N}(\underline{a}_m, \underline{\theta}_m) \underline{G}(\omega)] \underline{a}_m. \quad (3-46)$$

then from (3-38) and (3-39)

$$||\psi(\underline{a}_m, \underline{\theta}_m, \omega)|| > ||\underline{H}(\underline{a}_m, \underline{\theta}_m, \omega)||, \forall (\underline{a}_m, \underline{\theta}_m, \omega) \in \partial\Omega \quad (3-47)$$

which, as in the previous case, implies ψ and Ω are homotopic on $\partial\Omega$.

Hence if the singularity is non-degenerate, which is implied by (3-42), the conclusion follows. ■

CHAPTER IV

GRAPHICAL RESULTS FOR SINGLE INPUT DF

The first result presents a graphical technique that gives sufficient conditions for oscillation when the nonlinear function is an odd power law. Generalization to other odd functions follows in Chapter VI. Conditions are also given for absence of oscillations.

Theorem III: Let S satisfy (3-1) and have nonlinearity $n(x) = x^p$; p odd.

Let there be a region Ω in the (a, ω) plane, homeomorphic to a disc.

1) Suppose there is a DF solution $(\hat{a}, \hat{\omega}) \in \Omega$ and

$$|1/G(j\omega) + N(a)| > \sigma(a, \omega) \text{ on } \partial\Omega \quad (4-1)$$

where σ is a positive solution to

$$\lambda = p(1 + \frac{2\sigma}{\lambda})^{p-1} a^{p-1} \quad (4-2)$$

$$\frac{2\sigma}{\lambda} = \frac{p(1 + \frac{2\sigma}{\lambda})^{p-1} a^{p-1}}{\inf_{k > 1} \left| \frac{2}{G(jk\omega)} + p(1 + \frac{2\sigma}{\lambda})^{p-1} a^{p-1} \right|} \quad (4-3)$$

and $-1/G(j\omega)$ is not parallel to $N(a)$ at $\omega = \hat{\omega}$, then a π -symmetric oscillation exists with $(a, \omega) \in \Omega$.

2) Suppose that

$$|1/G(j\omega) + N(a)| > \sigma(a, \omega) \quad \forall (a, \omega) \in \Omega \quad (4-4)$$

where $\sigma(a, \omega)$ is given by (4-2), (4-3). Then there is no oscillation with amplitude and frequency (a, ω) in Ω .

Proof: Suppose an oscillatory solution (3-14) exists and $|x(t)|_S < \infty$, then $|x|_1 < \infty$. To see this, take λ to be any positive number satisfying

$$\lambda \geq \left| \frac{dn(x)}{dx} \right|_S. \quad (4-5)$$

Solutions with convergent fourier series satisfy $|x|_2 < \infty$. One finds, using the mean value theorem,

$$\frac{1}{2\pi} \int_0^{2\pi} n^2(x(\phi)) d\phi \leq \frac{\lambda^2}{2\pi} \int_0^{2\pi} |x^2(\phi)| d\phi. \quad (4-6)$$

Hence $|n(x)|_2 < \infty$. Set

$$y = n(x(t)) = \sum_{k=-\infty}^{\infty} B_k e^{jk\omega t}.$$

If the linear element has a transform $G(j\omega)$,

$$\sum_{k=-\infty}^{\infty} A_k e^{jk\omega t} = \sum_{k=-\infty}^{\infty} G(jk\omega) B_k e^{jk\omega t}$$

since, from orthogonality, $A_k = G(jk\omega) B_k$. Observe that

$$\sum_{k=-\infty}^{\infty} |A_k| = \sum_{k=-\infty}^{\infty} |G(jk\omega) B_k| \quad (4-7)$$

and, applying the Cauchy-Schwarz inequality,

$$\sum_{k=-\infty}^{\infty} |A_k| \leq \left(\sum_{k=-\infty}^{\infty} |G(jk\omega)|^2 \right)^{1/2} \left(\sum_{k=-\infty}^{\infty} |B_k|^2 \right)^{1/2}. \quad (4-8)$$

It was stated in Chapter III that g satisfies

$$\sup_{0 < m < \infty} |mG(jm\omega)| < \infty$$

so that

$$\left(\sum_{k=1}^{\infty} |G(jk\omega)|^2 \right)^{1/2} < \infty. \quad (4-9)$$

Hence $|x|_1 < \infty$.

The operator P_*^1 may be applied to (3-4) yielding

$$x_* = P_*^1 g n(x_1 + x_*). \quad (4-10)$$

Consider two points, x_*' , x_*'' , with the metric $|x_*'' - x_*'|_2$. From (4-10) one obtains

$$\left(\int_0^{2\pi} (x_*''(\phi) - x_*'(\phi))^2 d\phi \right)^{1/2} = \left(\int_0^{2\pi} (P_*^1 g \{n[x''(\phi)]\} \right. \\ \left. - P_*^1 g \{n[x'(\phi)]\})^2 d\phi \right)^{1/2}.$$

The mean value theorem implies that

$$|n(x'') - n(x')| \leq \lambda |x'' - x'|$$

and since $P_*^1 g$ is linear, one sees that

$$\left(\int_0^{2\pi} (x_{*''}(\phi) - x_{*' }(\phi))^2 d\phi \right)^{1/2} \leq \lambda \left(\int_0^{2\pi} (P_{*'}^{-1} g \{x''(\phi) - x'(\phi)\})^2 d\phi \right)^{1/2}.$$

Applying Parseval's identity, it follows that

$$\left(\sum_{|k| > 1}^{\infty} |A_k'' - A_k'|^2 \right)^{1/2} \leq \lambda \left(\sum_{|k| > 1}^{\infty} |G(jk\omega) (A_k'' - A_k')|^2 \right)^{1/2}$$

and hence

$$\begin{aligned} & \left(\sum_{|k| > 1}^{\infty} |A_k'' - A_k'|^2 \right)^{1/2} \\ & \leq \lambda \sup_{k > 1} |G(jk\omega)| \left(\sum_{|k| > 1}^{\infty} |A_k'' - A_k'|^2 \right)^{1/2}. \end{aligned} \quad (4-11)$$

Hence one sees that $\|P_{*'}^{-1} g x'' - P_{*'}^{-1} g x'\|_2 \leq \lambda \sup_{k > 1} |G(jk\omega)| \|x'' - x'\|_2$.

Now obtain a bound on $\|x\|_S$ by using the norm $\|x\|_1$. From (4-10) one obtains

$$\|x\|_S \leq \sum_{|k| > 1} |A_k| \leq \sup_{|k| > 1} |G(jk\omega)| \sum_{|k| > 1} |B_k|.$$

For a power law nonlinearity, take

$$\lambda \geq P \|x\|_1^{p-1} \geq \left| \frac{dn(x)}{dx} \right|, \quad (4-12)$$

which satisfies (4-5). It is easy to verify that

$$\sum_{|k| > 1} |B_k| \leq (\|x\|_1)^p \leq \lambda \|x\|_1.$$

so that

$$\sum_{|k| > 1} |A_k| \leq \lambda \sup_{|k| > 1} |G(jk\omega)| \left(\sum_{k=-\infty}^{\infty} |A_k| \right). \quad (4-13)$$

Comparing (4-11) and (4-13) it can be seen that

$$|x_*'' - x_*'|_2 \leq |f|_s |x_*'' - x_*'|_2 \quad (4-14)$$

$$|x_*|_1 \leq |f|_s |x_*|_1 + |f|_s |x_1|_1 \quad (4-15)$$

with $|f|_s = \lambda \sup_{|k| > 1} |G(jk\omega)|$.

Note that, if $|f|_s < 1$, then (4-10) is contractive under the L_2 norm by (4-11) and (4-13) bounds the value of $|x_*|$, as a function of $|x_1|_1$. By applying the contraction mapping theorem, one may obtain bounds on $|x|_2$. Similarly, one may solve (4-15) for $|x|_1$.

The slope of the nonlinearity may vary from 0 to $\lambda(|x|_1)$ for a particular solution; Holtzman [68] shows that a sharper contraction results, in this case, if a quantity equal to half the norm of a recursive mapping is added to both sides. From (4-10) one obtains

$$x_* \left(1 + \frac{P_*^{-1} g \lambda(|x|_1)}{2} \right) = P_*^{-1} g \left(\frac{\lambda(|x|_1) x_*}{2} - n(x_1 + x_*) \right). \quad (4-16)$$

Provided that

$$\inf_{\substack{k > 1 \\ k \text{ odd}}} |1 + G(jk\omega) \lambda(|x|_1)/2| \neq 0, \quad (4-17)$$

it may be shown that (4-16) yields the relation

$$|x_*'' - x_*'|_2 \leq \sup_{\substack{k > 1 \\ k \text{ odd}}} \left| \frac{1}{\frac{2}{P_*^{-1} g \lambda(|x|_1)} + 1} \right| |x_*'' - x_*'|_2. \quad (4-18)$$

The map (4-10) is contractive if

$$\rho = \inf_{k > 1} \left| \frac{\lambda(|x|_1)}{\frac{2}{G(jk\omega)} + \lambda(|x|_1)} \right| < 1. \quad (4-19)$$

For a certain region in (\underline{a}, ω) space, (4-19) is satisfied. Then (4-10) has a unique fixed point in this region satisfying

$$|x_* - x_*^0|_2 \leq \frac{|x_*^1 - x_*^0|_2}{1 - \rho} \quad (4-20)$$

where x_*^0 is a starting point and x_*^1 is obtained by applying the map to x_*^0 . Take $x_*^0 = 0$, and from (4-20) and (4-16) one obtains

$$\begin{aligned} \|x_*\| &\leq \frac{1}{1 - \rho} \left\| \frac{P_*^{-1} g \left[\frac{\lambda(|x|_1) x_1}{2} - n(x_1) \right]}{1 + \frac{P_*^{-1} g \lambda(|x|_1)}{2}} \right\| \\ &\leq \inf_{k > 1} \frac{\lambda(|x|)}{\left| \frac{2}{G(jk\omega)} + \lambda(|x|_1) \right| - \lambda(|x|_1)} \|x_1\|, \end{aligned} \quad (4-21)$$

where use has been made of $P_*^{-1} g \lambda(|x|_1) x_1 = 0$. Hence a bound on $\|x_*\|$ exists as a function of $\|x_1\|$ and $\lambda(|x|_1)$.

One now finds an expression for the DF harmonic error. Applying P^1 to (3-4) yields

$$x_1 = -P^1 g n(x_1 + x_*) \quad (4-22)$$

The equation of harmonic balance is related to the DF equation by

$$x_1 + P^1 g n(x_1 + x_*) = [x_1 + P g n x_1] + P^1 g [n(x_1 + x_*) - n x_1] \quad (4-23)$$

When (4-22) holds, it is seen that the DF error is given by

$$P^1 g [n x_1 - n(x_1 + x_*) + \frac{\lambda(|x|_1)}{2} x_*] \quad (4-24)$$

where use has been made of $P^1 g \frac{\lambda(|x|_1)}{2} x_* = 0$. Taking norms on both sides of (4-24) yields

$$|1/G(j\omega) + N(a)| a \leq \|n(x_1 + x_*) - n x_1 - \frac{\lambda(|x|_1)}{2} x_*\| \quad (4-25)$$

and the right side of (4-25) is evaluated from the mean value theorem as

$$\begin{aligned} \|n(x_1 + x_*) - n x_1 - \frac{\lambda(|x|_1)}{2} x_*\| &\leq \left\| \frac{dn}{dx} x_* - \frac{\lambda(|x|_1)}{2} x_* \right\| \\ &\leq \frac{\lambda(|x|_1)}{2} \|x_*\|. \end{aligned}$$

The last step follows since $0 < \frac{dn}{dx} < \lambda$. Combining (4-25) with (4-20) yields

$$|1/G(j\omega) + N(a)| \leq \frac{\lambda^2(|x|_1)/4}{\inf_{k > 1} \left| 1/G(jk\omega) + \frac{\lambda(|x|_1)}{2} \right| - \frac{\lambda(|x|_1)}{2}} \quad (4-26)$$

The right hand side of (4-26) may be interpreted as an error distance, and for convenience define σ by

$$\sigma = \frac{\lambda^2(|x|_1)/4}{\inf_{k > 1} \left| \frac{1}{G(jk\omega)} + \frac{\lambda(|x|_1)}{2} \right| - \frac{\lambda(|x|_1)}{2}} \quad (4-27)$$

A suitable value for λ will now be determined for the power law non-linearity. One may write

$$n(x) = x^p; \quad \frac{dn}{dx} = px^{p-1}.$$

Equation (4-21) gives bounds on $|x_*|_1$ in terms of $|x|_1$, and, from (4-27), one obtains

$$|x|_1 \leq |x|_1 + |x_*|_1 \leq \left(1 + \frac{2\sigma}{\lambda}\right) a. \quad (4-28)$$

Choose λ to be the positive solution of

$$\lambda = P \left(1 + \frac{2\sigma}{\lambda}\right)^{p-1} a^{p-1} \geq P|x|_1^{p-1} \geq \frac{dn}{dx}, \quad (4-29)$$

which will be assumed to exist. It follows that (4-29) satisfies (4-4) and (4-10). Substituting (4-29) in (4-27) one obtains

$$\frac{2\sigma}{\lambda} = \frac{P \left(1 + \frac{2\sigma}{\lambda}\right)^{p-1} a^{p-1}}{\inf_{k > 1} \left| \frac{2}{G(jk\omega)} + P \left(1 + \frac{2\sigma}{\lambda}\right)^{p-1} a^{p-1} \right| - P \left(1 + \frac{2\sigma}{\lambda}\right)^{p-1} a^{p-1}} \quad (4-30)$$

or after some rearrangement,

$$\frac{2\sigma}{\lambda} = \frac{P(1 + \frac{2\sigma}{\lambda})^p a^{p-1}}{\inf_{k > 1} \left| \frac{2}{G(jk\omega)} + P(1 + \frac{2\sigma}{\lambda})^{p-1} a^{p-1} \right|}. \quad (4-31)$$

A positive solution for $\frac{2\sigma}{\lambda}$ in (4-30) implies that (4-17) is satisfied; hence the conditions for contraction are verified and x_* is unique.

Hence the conditions of Theorem I are satisfied. The proof is complete. ■

It is possible to show that (4-3) has a positive solution when $\frac{2\sigma}{\lambda}$ is small. Let it be assumed that k can be found independent of λ . It is intended to solve iteratively on a computer the equation

$$\frac{2\sigma}{\lambda} = F\left(\frac{2\sigma}{\lambda}\right) \quad (4-32)$$

which is equivalent to (4-3). Now (4-32) can be sketched as the parametric equations

$$\frac{2\sigma}{\lambda} = F(x); \quad x = \frac{2\sigma}{\lambda}.$$

The first equation has a positive solution when $x = 0$; if its slope is less than one for a long enough distance along the x axis, then (4-32) will have a solution; if not, the iterations will soon lead to a negative denominator in (4-3). The situation has been sketched in Figure 4-2. A sufficient condition for the procedure to be successful is that

$$|F'(x)| < 1. \quad (4-33)$$

The derivative of F with respect to x can be computed, yielding

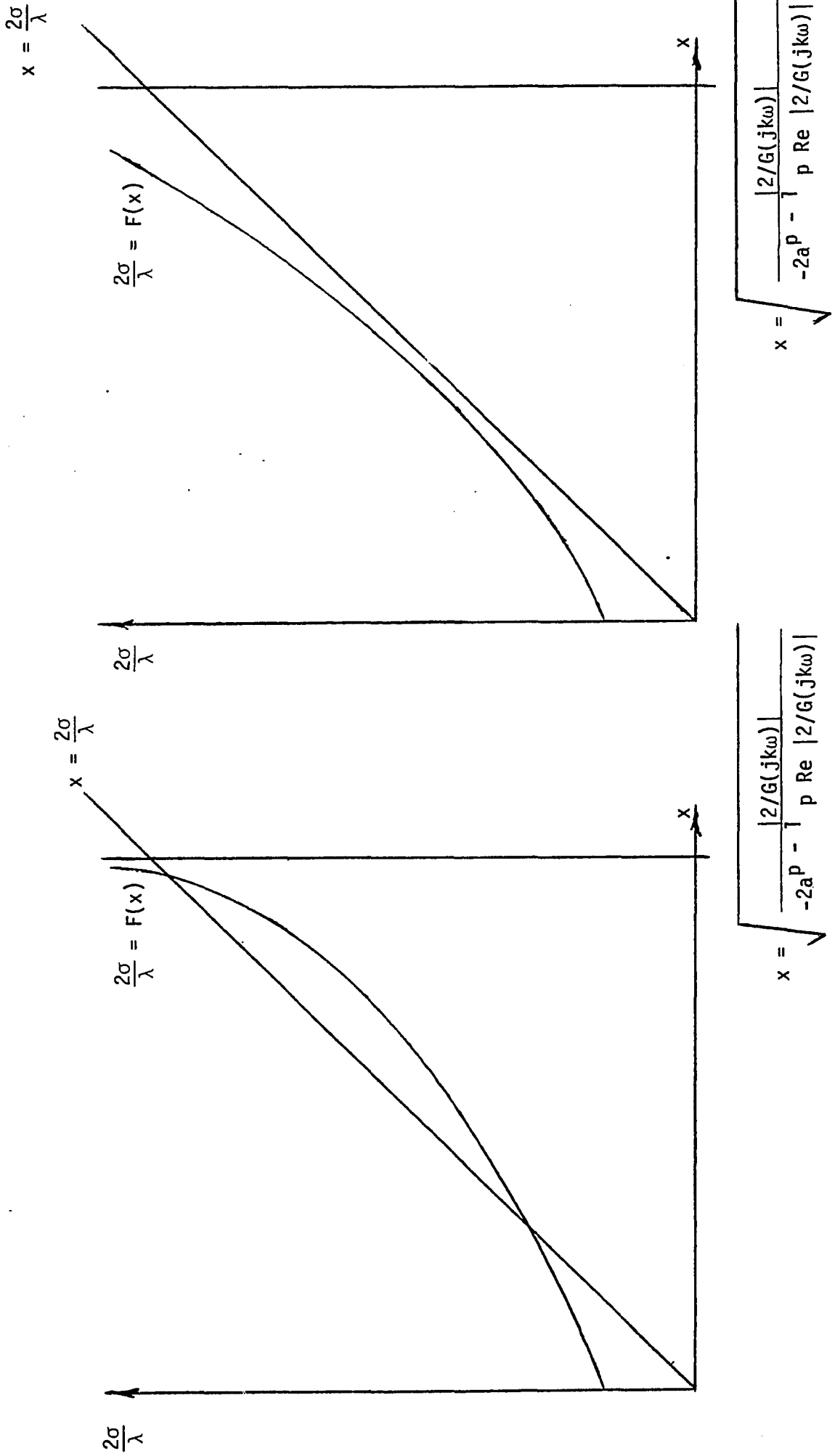

a) solution exists

b) no solution exists

FIGURE 4-1 CONDITIONS FOR SOLUTION OF $F(\frac{2\sigma}{\lambda}) = \frac{2\sigma}{\lambda}$

$$F'(x) = \frac{pF(x)}{1+x} - \left(\frac{F(x)}{1+x}\right)^2$$

$$\cdot (p-1) \cdot \frac{2 \operatorname{Re} (2/G(jk\omega) + p(1+x)^{p-1} a^{p-1})}{|2/G(jk\omega) + p(1+x)^{p-1} a^{p-1}|} \cdot \quad (4-34)$$

Note that $\operatorname{Re}(2/G(jk\omega)) < 0$, and from (4-17), (4-34) is always positive. A sufficient condition for (4-33) to hold is

$$x = F(x) \leq \frac{2}{3p} \quad (4-35)$$

i.e., one can expect the technique to work when the percentage harmonic content is on the order of (4-35).

It turns out, because the system is usually low pass, the infimum required (assuming a π -symmetric solution) in (4-3) usually occurs at $k = 3$. A computer can be used to sketch the region Ω in the (a, ω) plane, and examples of the technique are shown in Figures 4-2 to 4-6 for various combinations of linear function and odd power law.

1.81

.05s/s2-.05s+1
A

2.21

OMEGA	RE 1/G(JW)	IM 1/G(JW)	IG(JW)1
.990000	-1.000000	-.402020	1.077785
.990339	-1.000000	-.388326	1.072752
.990678	-1.000000	-.374637	1.067873
.991017	-1.000000	-.360952	1.063149
.991356	-1.000000	-.347272	1.058583
.991695	-1.000000	-.333597	1.054176
.992034	-1.000000	-.319926	1.049930
.992373	-1.000000	-.306261	1.045847
.992712	-1.000000	-.292600	1.041928
.993051	-1.000000	-.278943	1.038176
.993390	-1.000000	-.265292	1.034592
.993729	-1.000000	-.251645	1.031177
.994068	-1.000000	-.238002	1.027932
.994407	-1.000000	-.224365	1.024861
.994746	-1.000000	-.210732	1.021963
.995085	-1.000000	-.197104	1.019240
.995423	-1.000000	-.183480	1.016693
.995762	-1.000000	-.169861	1.014324
.996101	-1.000000	-.156247	1.012133
.996440	-1.000000	-.142637	1.010121
.996779	-1.000000	-.129032	1.008290
.997118	-1.000000	-.115432	1.006640
.997457	-1.000000	-.101836	1.005172
.997796	-1.000000	-.088245	1.003886
.998135	-1.000000	-.074658	1.002783
.998474	-1.000000	-.061077	1.001863
.998813	-1.000000	-.047499	1.001127
.999152	-1.000000	-.033927	1.000575
.999491	-1.000000	-.020359	1.000207
.999830	-1.000000	-.006795	1.000023
1.000169	-1.000000	.006751	1.000023
1.000507	-1.000000	.020289	1.000206
1.000847	-1.000000	.033860	1.000573
1.001185	-1.000000	.047388	1.001122
1.001525	-1.000000	.060950	1.001856
1.001863	-1.000000	.074469	1.002769
1.002202	-1.000000	.087984	1.003863
1.002542	-1.000000	.101532	1.005141
1.002880	-1.000000	.115038	1.006595
1.003220	-1.000000	.128577	1.008232
1.003558	-1.000000	.142073	1.010042
1.003898	-1.000000	.155603	1.012034
1.004236	-1.000000	.169090	1.014195
1.004576	-1.000000	.182611	1.016537
1.004914	-1.000000	.196090	1.019044
1.005253	-1.000000	.209563	1.021722
1.005592	-1.000000	.223071	1.024578
1.005931	-1.000000	.236535	1.027594
1.006270	-1.000000	.250033	1.030785
1.006609	-1.000000	.263489	1.034131
1.006948	-1.000000	.276978	1.037650
1.007287	-1.000000	.290425	1.041320
1.007626	-1.000000	.303867	1.045148
1.007965	-1.000000	.317343	1.049146
1.008304	-1.000000	.330776	1.053287
1.008643	-1.000000	.344243	1.057593
1.008982	-1.000000	.357667	1.062038
1.009321	-1.000000	.371125	1.066646
1.009660	-1.000000	.384540	1.071387

FIGURE 4-2 PROOF OF OSCILLATION BY THEOREM III

$$n(x) = 1/3x^3$$

$$G(s) = \frac{.05s}{s^2 - .05s + 1}$$

1.71

S-1/S4+S3-12S2-12
A

2.31

OMEGA	RE 1/G(JW)	IM 1/G(JW)	IG(JW)1
.980000	-.698600	.256564	.740222
.980678	-.708862	.247981	.750986
.981356	-.719121	.239390	.757920
.982034	-.729377	.230791	.765020
.982712	-.739631	.222183	.772282
.983390	-.749881	.213567	.779700
.984068	-.760127	.204944	.787271
.984746	-.770370	.196313	.794990
.985424	-.780611	.187673	.802854
.986102	-.790848	.179026	.810858
.986780	-.801081	.170370	.818997
.987457	-.811311	.161707	.827270
.988135	-.821539	.153035	.835671
.988813	-.831763	.144356	.844197
.989491	-.841984	.135669	.852844
.990169	-.852201	.126974	.861608
.990847	-.862416	.118270	.870488
.991525	-.872627	.109559	.879478
.992203	-.882835	.100840	.888575
.992881	-.893039	.092113	.897777
.993559	-.903242	.083378	.907082
.994237	-.913440	.074635	.916484
.994915	-.923635	.065885	.925981
.995593	-.933826	.057126	.935572
.996271	-.944016	.048359	.945253
.996949	-.954201	.039545	.955022
.997627	-.964383	.030803	.964875
.998305	-.974562	.022013	.974810
.998983	-.984738	.013215	.984827
.999661	-.994911	.004410	.994920
1.000339	-.005078	-.004402	1.005088
1.001017	-1.015246	-.013225	1.015332
1.001694	-1.025396	-.022043	1.025633
1.002372	-1.035557	-.030881	1.036017
1.003050	-1.045715	-.039727	1.046470
1.003728	-1.055870	-.048581	1.056987
1.004406	-1.066022	-.057442	1.067568
1.005084	-1.076170	-.066312	1.078211
1.005762	-1.086315	-.075189	1.088914
1.006440	-1.096457	-.084073	1.099674
1.007118	-1.106596	-.092966	1.110494
1.007795	-1.116717	-.101854	1.121353
1.008473	-1.126850	-.110762	1.132280
1.009151	-1.136979	-.119677	1.143260
1.009830	-1.147105	-.128601	1.154291
1.010508	-1.157227	-.137532	1.165371
1.011186	-1.167347	-.146471	1.176500
1.011864	-1.177463	-.155417	1.187676
1.012542	-1.187576	-.164371	1.198897
1.013220	-1.197688	-.173333	1.210164
1.013897	-1.207778	-.182290	1.221457
1.014575	-1.217882	-.191267	1.232809
1.015253	-1.227982	-.200252	1.244203
1.015931	-1.238079	-.209244	1.255636
1.016609	-1.248173	-.218244	1.267109
1.017287	-1.258263	-.227252	1.278620
1.017965	-1.268350	-.236267	1.290168
1.018643	-1.278434	-.245289	1.301753
1.019321	-1.288515	-.254320	1.313374

FIGURE 4-3 PROOF OF OSCILLATION BY THEOREM III

$$n(x) = 1/3x^3$$

$$G(s) = \frac{s - 1}{s^4 + s^3 - 12s^2 - 12}$$

OMEGA	RE 1/G(JW)	IM 1/G(JW)	IG(JW)1
.990000	-1.004475	.134007	1.013374
.990339	-1.004174	.129442	1.012483
.990678	-1.003884	.124879	1.011622
.991017	-1.003605	.120317	1.010791
.991356	-1.003335	.115757	1.009991
.991695	-1.003077	.111199	1.009222
.992034	-1.002829	.106642	1.008483
.992373	-1.002591	.102087	1.007775
.992712	-1.002364	.097533	1.007098
.993051	-1.002147	.092981	1.006451
.993390	-1.001940	.088431	1.005835
.993729	-1.001744	.083882	1.005250
.994068	-1.001559	.079334	1.004696
.994407	-1.001384	.074788	1.004173
.994746	-1.001219	.070244	1.003680
.995085	-1.001065	.065701	1.003218
.995423	-1.000921	.061160	1.002787
.995762	-1.000787	.056620	1.002387
.996101	-1.000664	.052082	1.002018
.996440	-1.000551	.047546	1.001680
.996779	-1.000448	.043011	1.001372
.997118	-1.000356	.038477	1.001095
.997457	-1.000274	.033945	1.000849
.997796	-1.000202	.029415	1.000634
.998135	-1.000140	.024886	1.000450
.998474	-1.000089	.020359	1.000296
.998813	-1.000048	.015833	1.000173
.999152	-1.000017	.011309	1.000081
.999491	-.999997	.006786	1.000020
.999830	-.999987	.002265	.999989
1.000169	-.999987	-.002250	.999989
1.000507	-.999997	-.006763	1.000020
1.000847	-1.000017	-.011287	1.000081
1.001185	-1.000048	-.015796	1.000173
1.001525	-1.000089	-.020317	1.000295
1.001863	-1.000139	-.024823	1.000447
1.002202	-1.000200	-.029328	1.000630
1.002542	-1.000272	-.033844	1.000844
1.002880	-1.000353	-.038346	1.001088
1.003220	-1.000445	-.042859	1.001362
1.003558	-1.000546	-.047358	1.001666
1.003898	-1.000658	-.051868	1.002001
1.004236	-1.000780	-.056364	1.002366
1.004574	-1.000912	-.060870	1.002761
1.004914	-1.001054	-.065363	1.003185
1.005253	-1.001205	-.069855	1.003639
1.005592	-1.001368	-.074357	1.004125
1.005931	-1.001540	-.078845	1.004638
1.006270	-1.001722	-.083345	1.005183
1.006609	-1.001914	-.087830	1.005756
1.006948	-1.002116	-.092326	1.006361
1.007287	-1.002328	-.096808	1.006993
1.007626	-1.002550	-.101289	1.007654
1.007965	-1.002783	-.105781	1.008347
1.008304	-1.003025	-.110259	1.009067
1.008643	-1.003277	-.114748	1.009818
1.008982	-1.003539	-.119222	1.010596
1.009321	-1.003811	-.123708	1.011405
1.009660	-1.004093	-.128180	1.012242

FIGURE 4-4 PROOF OF OSCILLATION BY THEOREM III

$$n(x) = 1/3x^3$$

$$G(s) = \frac{.09s^2}{s^4 - .6s^3 + 1.81s^2 - .6s + 1}$$

1.80	.02S/92-.02S+1 A	2.20	OMEGA	RE 1/G(JW)	IM 1/G(JW)	IG(JW)1
			.990000	-1.000000	-1.005050	1.417789
			.990339	-1.000000	-.970815	1.393729
			.990678	-1.000000	-.936591	1.370111
			.991017	-1.000000	-.902380	1.346956
			.991356	-1.000000	-.868180	1.324287
			.991695	-1.000000	-.833992	1.302130
			.992034	-1.000000	-.799816	1.280510
			.992373	-1.000000	-.765652	1.259453
			.992712	-1.000000	-.731499	1.238988
			.993051	-1.000000	-.697358	1.219142
			.993390	-1.000000	-.663229	1.199947
			.993729	-1.000000	-.629112	1.181432
			.994068	-1.000000	-.595006	1.163629
			.994407	-1.000000	-.560912	1.146570
			.994746	-1.000000	-.526829	1.130287
			.995085	-1.000000	-.492759	1.114814
			.995423	-1.000000	-.458700	1.100184
			.995762	-1.000000	-.424652	1.086430
			.996101	-1.000000	-.390617	1.073583
			.996440	-1.000000	-.356593	1.061677
			.996779	-1.000000	-.322580	1.050742
			.997118	-1.000000	-.288579	1.040806
			.997457	-1.000000	-.254590	1.031899
			.997796	-1.000000	-.220612	1.024046
			.998135	-1.000000	-.186646	1.017269
			.998474	-1.000000	-.152692	1.011590
			.998813	-1.000000	-.118749	1.007026
			.999152	-1.000000	-.084817	1.003591
			.999491	-1.000000	-.050897	1.001294
			.999830	-1.000000	-.016989	1.000144
			1.000169	-1.000000	.016879	1.000142
			1.000507	-1.000000	.050722	1.001286
			1.000847	-1.000000	.084650	1.003576
			1.001185	-1.000000	.118471	1.006993
			1.001525	-1.000000	.152376	1.011543
			1.001863	-1.000000	.186174	1.017183
			1.002202	-1.000000	.219960	1.023906
			1.002542	-1.000000	.253831	1.031712
			1.002880	-1.000000	.287594	1.040534
			1.003220	-1.000000	.321442	1.050393
			1.003558	-1.000000	.355183	1.061205
			1.003898	-1.000000	.389008	1.072999
			1.004236	-1.000000	.422726	1.085678
			1.004576	-1.000000	.456528	1.099281
			1.004914	-1.000000	.490224	1.113696
			1.005253	-1.000000	.523908	1.128929
			1.005592	-1.000000	.557676	1.144990
			1.005931	-1.000000	.591338	1.161758
			1.006270	-1.000000	.625084	1.179292
			1.006609	-1.000000	.658723	1.197462
			1.006948	-1.000000	.692446	1.216339
			1.007287	-1.000000	.726063	1.235784
			1.007626	-1.000000	.759668	1.255825
			1.007965	-1.000000	.793357	1.276486
			1.008304	-1.000000	.826940	1.297625
			1.008643	-1.000000	.860607	1.319335
			1.008982	-1.000000	.894168	1.341468
			1.009321	-1.000000	.927812	1.364124
			1.009660	-1.000000	.961350	1.387153

FIGURE 4-5 PROOF OF OSCILLATION BY THEOREM III

$$n(x) = .1x^5$$

$$G(s) = \frac{.02s}{s^2 - .02s + 1}$$

1.80

2.20

OMEGA	RE 1/G(JW)	IM 1/G(JW)	IG(JW)1
1.009660	-1.000000	2.563599	2.751730
1.008982	-1.000000	2.474163	2.668611
1.008644	-1.000000	2.384045	2.585649
1.008304	-1.000000	2.205173	2.421319
1.007965	-1.000000	2.115618	2.340051
1.007626	-1.000000	2.025780	2.259156
1.007287	-1.000000	1.936165	2.179160
1.006948	-1.000000	1.846521	2.099614
1.006609	-1.000000	1.756593	2.021292
1.006270	-1.000000	1.666888	1.943841
1.005931	-1.000000	1.576901	1.867248
1.005592	-1.000000	1.487136	1.792086
1.005253	-1.000000	1.397088	1.718096
1.004914	-1.000000	1.307263	1.645885
1.004576	-1.000000	1.217408	1.575462
1.004236	-1.000000	1.127269	1.506896
1.003898	-1.000000	1.037353	1.440869
1.003558	-1.000000	.947154	1.377353
1.003220	-1.000000	.857178	1.317101
1.002880	-1.000000	.766918	1.260223
1.002542	-1.000000	.676881	1.207506
1.002202	-1.000000	.586560	1.159333
1.001863	-1.000000	.496463	1.116456
1.001525	-1.000000	.406335	1.079402
1.001185	-1.000000	.315922	1.048717
1.000847	-1.000000	.225733	1.025161
1.000507	-1.000000	.135259	1.009106
1.000169	-1.000000	.045303	1.001026
.999830	-1.000000	-.045303	1.009169
.999491	-1.000000	-.135726	1.025259
.999152	-1.000000	-.226179	1.048940
.998813	-1.000000	-.316663	1.079719
.998474	-1.000000	-.407177	1.117018
.998135	-1.000000	-.497723	1.160214
.997796	-1.000000	-.588299	1.208683
.997457	-1.000000	-.678906	1.261823
.997118	-1.000000	-.769544	1.319078
.996779	-1.000000	-.860213	1.379940
.996440	-1.000000	-.950913	1.443961
.996101	-1.000000	-1.041644	1.510742
.995762	-1.000000	-1.132406	1.579941
.995423	-1.000000	-1.223199	1.651259
.995085	-1.000000	-1.314023	1.724436
.994746	-1.000000	-1.404878	1.799252
.994407	-1.000000	-1.495764	1.875515
.994068	-1.000000	-1.586681	1.953059
.993729	-1.000000	-1.677629	2.031743
.993390	-1.000000	-1.768609	2.111442
.993051	-1.000000	-1.859620	2.192050
.992712	-1.000000	-1.950662	2.273474
.992373	-1.000000	-2.041736	2.355634
.992034	-1.000000	-2.132841	2.438457
.991695	-1.000000	-2.223977	2.521883
.991356	-1.000000	-2.315145	2.605857
.991017	-1.000000	-2.406344	2.690331
.990678	-1.000000	-2.497575	2.775262
.990339	-1.000000	-2.588837	2.860612
.990000	-1.000000	-2.680131	2.946422

FIGURE 4-6 PROOF OF OSCILLATION BY THEOREM III

$$n(x) = 1/35x^7$$

$$G(s) = \frac{.0075s}{s^2 - .0075s + 1}$$

CHAPTER V
ANALYTIC RESULTS FOR SINGLE INPUT DF

By using more conservative conditions, the existence of an oscillation can be verified analytically. In particular, the next theorem may be applied when the nonlinearity is an odd power law.

Theorem IV: Let S satisfy (3-1) and have nonlinearity

$$n(x) = x^p; p \text{ odd.}$$

Suppose

- 1) there is a DF solution $(\hat{a}, \hat{\omega})$ and $-1/G(j\omega)$ is not parallel to the real axis at $\omega = \hat{\omega}$, and
- 2) there is an interval along the ω axis

$$w = \{\omega : \omega_1 < \omega < \omega_2\} \text{ for which} \quad (5-1)$$

$$|\operatorname{Im}(1/G(j\omega))| \geq \left(1/2 + \frac{\sqrt{c_2 + c_2^2/4}}{4 + c_2}\right) |1/G(j\omega)|, \omega \in w \quad (5-2)$$

where c_2 is a positive solution of

$$c_2 = (p + 1) \frac{(p - 1)}{(p - 2)} \frac{(p - 3)}{(p - 4)} \dots \frac{4}{3} (1 + 1/c_2)^{p - 1}. \quad (5-3)$$

- 3) If there is a k such that

$$\inf_{i > 1} \left| \frac{2}{G(ji\omega)} + \bar{\lambda} \right| = \left| \frac{2}{G(jk\omega)} + \bar{\lambda} \right| \quad (5-4)$$

where $\bar{\lambda}$ is defined by

$$\bar{\lambda} = \max_{\omega \in W} \left[\left(c_2 + \frac{2c_2 \sqrt{c_2 + c_2^2/4}}{4 + c_2} \right) |1/G(j\omega)| \right] \quad (5-5)$$

and for that k

$$\frac{|1/G(jk\omega)|}{|1/G(j\omega)|} \geq (c_2 + c_2^2/2) + c_2 \sqrt{c_2 + c_2^2/4}, \quad \forall \omega \in W \quad (5-6)$$

then there is a π -symmetric oscillation with $\omega \in W$ and

$$a \leq \max_{\omega \in W} N^{-1} \left[1 + \frac{2 \sqrt{c_2 + c_2^2/4}}{4 + c_2} |1/G(j\omega)| \right]. \quad (5-7)$$

Proof: Define a rectangular region Ω' in the (a, ω) plane of convenient size by

$$\Omega' = \{a, \omega : a_1 < a < a_2, \omega_1 < \omega < \omega_2\} \quad (5-8)$$

such that $(\hat{a}, \hat{\omega}) \in \Omega'$. It will be demonstrated that under conditions (5-2) to (5-6) Ω' contains a disc Ω that satisfied Theorem III, see Figure 5-1.

The analysis will be done in the (N, ω) plane, where $N = N(a)$ is the DF. There is a one-to-one relationship between the set $N = \{N : N \in \mathbb{R}, N > 0\}$ and the set $a = \{a : a \in \mathbb{R}, a > 0\}$, and Ω' will also be used to denote the image of (5-8) in the (N, ω) plane. As a matter of notational convenience, the linear transfer functions will be represented by

$$|1/G(j\omega)| = G^{-1}; \quad |1/G(jk\omega)| = G_k^{-1}.$$

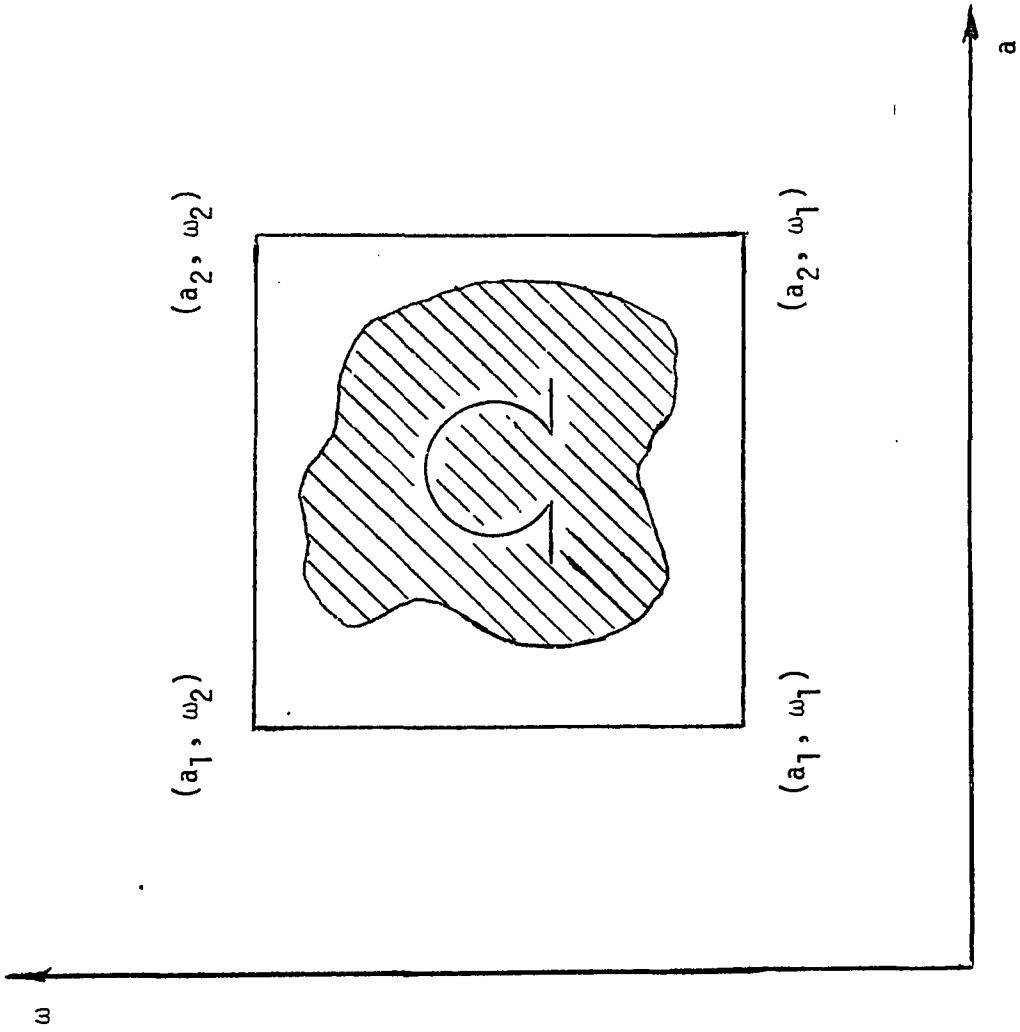

FIGURE 5-1 RELATION BETWEEN Ω AND Ω'

First, the existence of a positive solution to (4-2) and (4-3) will be verified from (5-1) through (5-6). The following holds for $c_2 > 0$:

$$\frac{1}{c_2} > \frac{1}{c_2} \left(\frac{2 + c_2/2 + \sqrt{c_2 + c_2^2/4}}{2 + c_2/2 + \sqrt{c_2 + c_2^2/4} + \sqrt{4/c_2 + 1}} \right) = \frac{4c_2 + c_2^2 + 2c_2 \sqrt{c_2 + c_2^2/4}}{2(4 + c_2) (c_2^2/2 + c_2 \sqrt{c_2 + c_2^2/4}) - 2(4c_2 + c_2^2 + 2c_2 \sqrt{c_2 + c_2^2/4})} \quad (5-9)$$

In particular, when c_2 is chosen to satisfy (5-3), it follows by comparing (5-9) with (5-5) and (5-6) that

$$\frac{1}{c_2} \geq \frac{\bar{\lambda}/2}{G_k^{-1} - \bar{\lambda}} = \frac{\bar{\lambda}/2}{(G_k^{-1} - \bar{\lambda}/2) - \bar{\lambda}/2} \geq \frac{\bar{\lambda}/2}{\left| 1/G(jk\omega) + \frac{\bar{\lambda}}{2} \right| - \frac{\bar{\lambda}}{2}} \quad (5-10)$$

provided, of course, that $G_k^{-1} - \bar{\lambda} > 0$. The expression on the right-hand side of (5-10) was identified in (4-27) so that

$$\frac{2\sigma}{\lambda} \leq \frac{1}{c_2} \quad (5-11)$$

By referring to any table of describing functions, e.g. [69], it may be seen that (5-3) can be written as

$$c_2 = \frac{Pa^{p-1}}{N(a)} (1 + 1/c_2)^{p-1} \quad (5-12)$$

and, from (5-11), one obtains the relation

$$N(a) c_2 \geq Pa^{p-1} \left(1 + \frac{2\sigma}{\lambda}\right)^{p-1} \frac{1}{a^{p-1}} = \lambda \quad (5-13)$$

The equality portion of (5-13) comes from (4-29).

It can now be shown that Ω' contains a region Ω on whose boundary $|1/G(j\omega) + N(a)| > \sigma$. In view of (4-1) and (5-11) it suffices to show that the following holds on $\partial\Omega$:

$$|\operatorname{Im}(1/G(j\omega))| > \sigma > \frac{\bar{\lambda}}{2c_2}. \quad (5-14)$$

Clearly if (5-2) holds then (5-14) is obtained. Along the N axis one finds the boundary of the region from (4-26) and (5-10) as

$$|1/G(j\omega) + N(a)| \geq \frac{\bar{\lambda}^2/4}{G_k^{-1} - \bar{\lambda}} \quad (5-15)$$

which, from (5-13), yields the relation

$$|G^{-1} - N| \geq \frac{c_2^2 N^2/4}{G_k^{-1} - c_2 N}. \quad (5-16)$$

This in turn requires examining solutions of

$$G^{-1} G_k^{-1} - (G_k^{-1} + c_2 G^{-1}) N + (c_2 + c_2^2/4) N^2 = 0 \quad (5-17a)$$

$$G^{-1} G_k^{-1} - (G_k^{-1} + c_2 G^{-1}) N + (c_2 - c_2^2/4) N^2 = 0. \quad (5-17b)$$

The minimum and maximum of the solutions on Ω' can be shown to be

$$N_1 = \min_{\omega \in \Omega'} \left\{ \frac{(G_k^{-1} + c_2 G^{-1}) - \sqrt{(G_k^{-1} + c_2 G^{-1})^2 + (c_2^2 - 4c_2) G^{-1} G_k^{-1}}}{2(c_2 - c_2^2/4)} \right\} \quad (5-18a)$$

$$N_2 = \max_{\omega \in \Omega} \left\{ \frac{(G_k^{-1} + c_2 G^{-1}) - \sqrt{(G_k^{-1} + c_2 G^{-1})^2 - (c_2^2 + 4c_2) G^{-1} G_k^{-1}}}{2(c_2 + c_2^2/4)} \right\} \quad (5-18b)$$

Now N_1 is always real and positive if $c_2 > 4$. N_2 will be real and positive if

$$\left(\frac{G_k^{-1}}{G^{-1}} \right) - (2c_2 + c_2^2) \frac{G_k^{-1}}{G^{-1}} + c_2 > 0 \quad (5-19)$$

which in turn requires

$$\frac{G_k^{-1}}{G^{-1}} \geq \frac{(2c_2 + c_2^2) + \sqrt{(2c_2 + c_2^2)^2 - 4c_2}}{2} \quad (5-20)$$

which is equivalent to (5-6).

All the requirements of Theorem III, condition 1, have been satisfied; hence an oscillation exists. The maximum value of N_2 may be computed from (5-13) and (5-5) as (5-7). ■

A graph of the parametric equations

$$c_2 = c_1(1 + x)^p - 1 \quad (5-21a)$$

$$x = 1/c_2 \quad (5-21b)$$

where c_1 is a positive constant, shows that there is a unique solution for c_2 . This is illustrated in Figure 5-2.

It is convenient to tabulate the values of c_2 and other pertinent parameters as functions of p ; this is done in Figure 5-3.

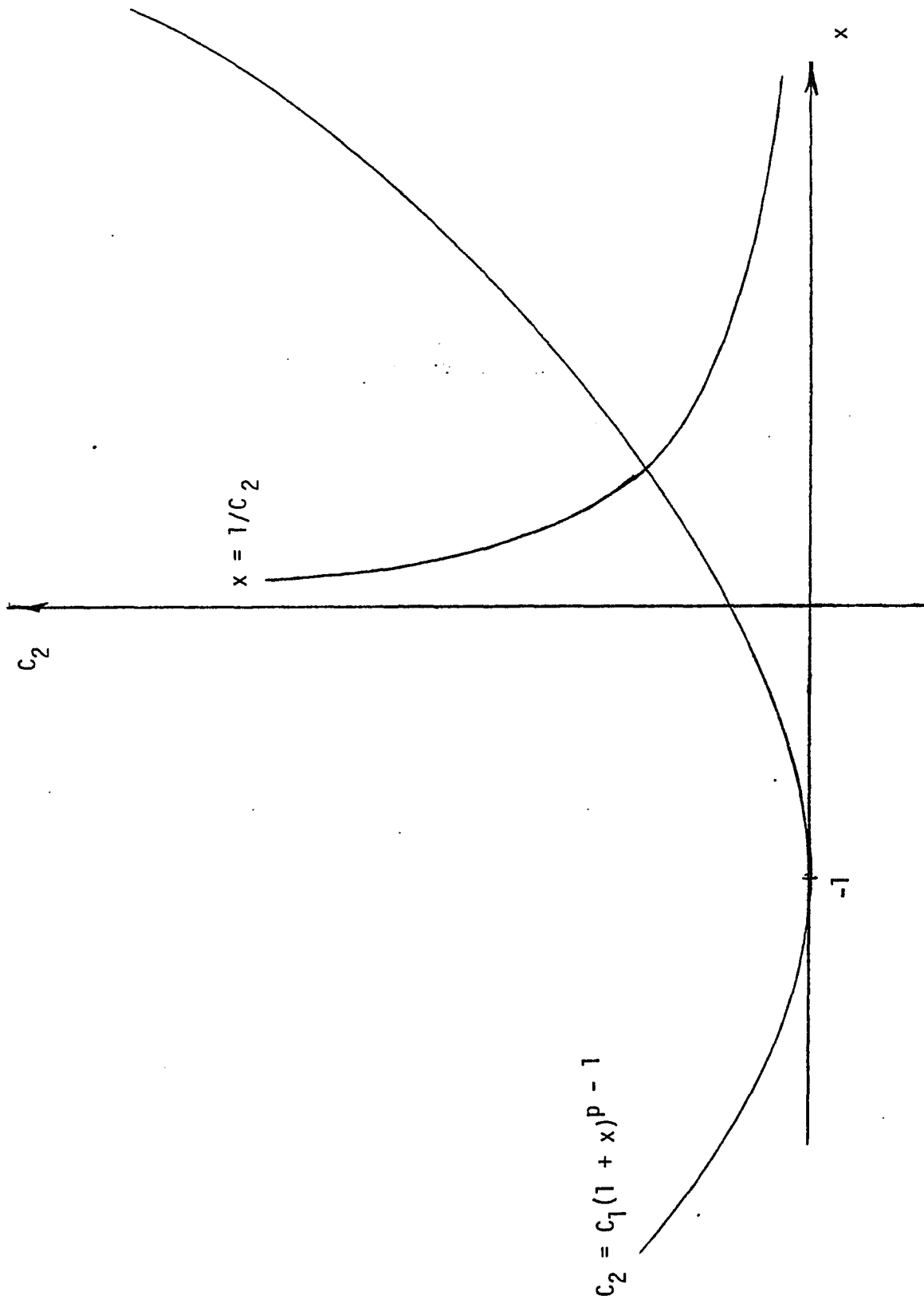

FIGURE 5-2 FINDING THE VALUE OF c_2

POWER	C2	IM(GI)/GI	LAMBDA/GI	GKI/GI	NMAX/GI
3	5.566316	0.88140077	9.812310	41.3675	1.76280154
5	11.247496	0.92943621	20.907659	148.1472	1.85887242
7	17.775694	0.95174909	33.836001	350.6255	1.90349818
9	25.019318	0.96426307	48.250408	675.0777	1.92852614
11	32.893728	0.97211770	63.953150	1146.8413	1.94423540
13	41.338526	0.97743450	80.811402	1790.5964	1.95486900
15	50.307824	0.98123430	98.727525	2630.5307	1.96246859
17	59.765242	0.98406350	117.625587	3690.4468	1.96812701
19	69.681024	0.98623861	137.444232	4993.8348	1.97247722
21	80.030247	0.98795443	158.132474	6563.9252	1.97590885
23	90.791646	0.98933684	179.647041	8423.7277	1.97867369
25	101.946797	0.99047049	201.950588	10596.0622	1.98094098
27	113.479539	0.99141416	225.010445	13103.5821	1.98282833
29	125.375545	0.99220988	248.797708	15968.7940	1.98441976
31	137.622000	0.99288837	273.286567	19214.0731	1.98577675
33	150.207354	0.99347262	298.453786	22861.6769	1.98694524
35	163.121126	0.99398008	324.278299	26933.7561	1.98796015
37	176.353750	0.99442425	350.740892	31452.3638	1.98884850
39	189.896447	0.99481573	377.823946	36439.4640	1.98963146
41	203.741126	0.99516292	405.511228	41916.9386	1.99032584
43	217.880297	0.99547257	433.787717	47906.5933	1.99094514
45	232.306997	0.99575016	462.639457	54430.1635	1.99150031
47	247.014739	0.99600017	492.053445	61509.3188	1.99200034
49	261.997452	0.99622632	522.017518	69165.6673	1.99245265

FIGURE 5-3 TABLE OF PARAMETERS VS. P

As an example of the use of Theorem IV, consider the system to be a Van der Pol oscillator whose transfer function is

$$G(s) = \frac{.03s}{s^2 - .03s + 1}$$

and the nonlinear function is

$$n(x) = 1/3x^3.$$

The describing function solution is $\hat{\omega} = 1$, $\hat{a} = 2$. The value of c_2 can be calculated from (5-3) as

$$c_2 = 4(1 + 1/c_2)^2; c_2 = 5.566.$$

One computes from (5-2)

$$\text{Im}|1/G(j\omega)| = .8814|1/G(j\omega)| \quad (5-26)$$

which, by using a trigonometric substitution can be shown equal to

$$\frac{\text{Im}|1/G(j\omega)|}{\text{Re}|1/G(j\omega)|} = 1.865 = \left| \frac{\omega^2 - 1}{.03\omega} \right| \quad (5-27)$$

$$\text{or } \omega^2 \pm .05595\omega - 1 = 0$$

yielding

$$\omega_1 = \frac{.05595 + \sqrt{(.05595)^2 + 4}}{2} = 1.0283662$$

$$\omega_2 = \frac{-.05595 + \sqrt{(.05595)^2 + 4}}{2} = .9724162.$$

Now compute $\bar{\lambda} = \max_{.972 < \omega < 1.02} [9.812|1/G(j\omega)|] = 44.1$. It is easy

to see that, when the solution is assumed π -symmetric, the infimum is

satisfied at $K = 3$. The final requirement of the theorem is that

$$\frac{|1/G(j3\omega)|}{|1/G(j\omega)|} \geq 41.36$$

is satisfied in the region

$$w = \{\omega: .9724162 \leq \omega \leq 1.0283662\}.$$

This is easily verified. The bound (5-7) is then found to be

$$a \leq N^{-1}[1.7628|1/G(j\omega)|] = 3.9485.$$

As a comparison, one might easily solve the problem graphically by applying Theorem III. This was done by computer in Figure 5-4, and the regions obtained by the two methods may be compared.

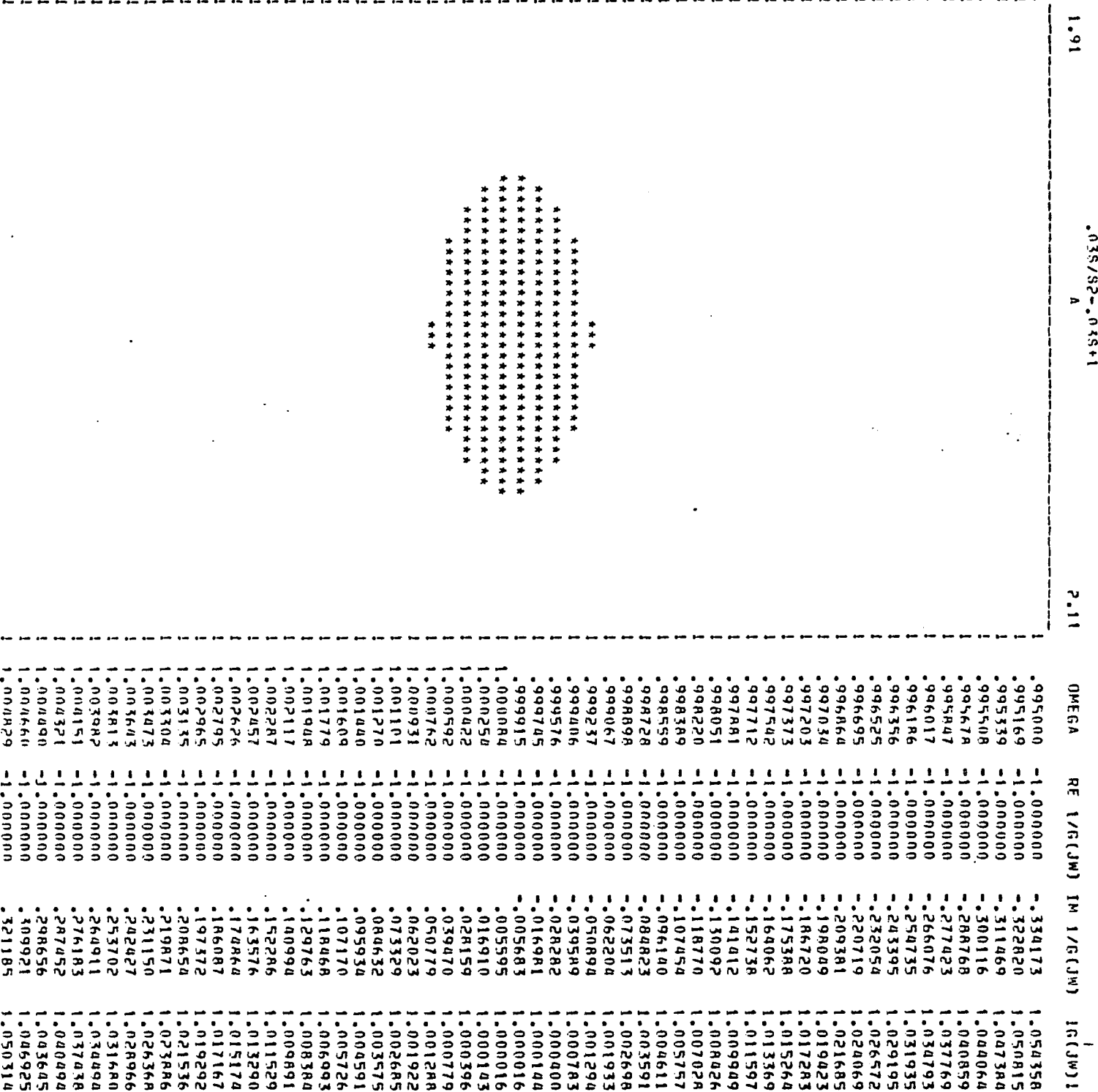

FIGURE 5-4 A PLOT OF THE REGION SURROUNDING THE DF SOLUTION WHEN

$$n(x) = 1/3x^3, G(s) = \frac{.03s}{s^2 - .03s + 1}$$

CHAPTER VI

EXTENDING THE METHOD TO MIDF AND MORE GENERAL NONLINEARITIES

A. Multiple Input Describing Functions

The results obtained for DF can be extended to multiple input describing functions (MIDF). One needs to deal with some higher dimensional spaces and use homotopy arguments to show the existence of a solution. It is also desired to define a more general set of characteristics that a nonlinearity must have for the method of Theorem III or IV to be applicable, and to determine the modifications necessary to the theorems.

The next result represents the MIDF analogue of Theorem III.

Theorem V: Let S satisfy (3-1) and have nonlinearity

$$n(x) = x^p; \quad p \text{ odd.}$$

Let there be a disc Ω in $(\underline{a}_m, \underline{\theta}_m, \omega)$ space.

1) Suppose there is an MIDF solution $(\hat{\underline{a}}_m, \hat{\underline{\theta}}_m, \omega) \in \Omega$ and on

$\partial\Omega$

$$||(\underline{G}^{-1}(\omega) + \underline{N}(\underline{a}_m, \underline{\theta}_m)) \underline{a}_m|| > ||\underline{a}_m|| \sigma \quad (6-1)$$

where σ is a positive quantity satisfying

$$A = \sum_{k=1}^m a_k \quad (6-2)$$

$$\lambda = p(1 + \frac{2\sigma}{\lambda})^p - \frac{1}{A} p - 1 \quad (6-3)$$

$$\frac{2\sigma}{\lambda} = \frac{p(1 + \frac{2\sigma}{\lambda})^p A^{p-1}}{\inf_{k > m} \left| \frac{2}{G(jk\omega)} + p(1 + \frac{2\sigma}{\lambda})^{p-1} A^{p-1} \right|} \quad (6-4)$$

and

$$J \left(\frac{[1 + \underline{G}(\omega) \underline{N}(\underline{a}_m, \underline{\theta}_m)] \underline{a}_m}{\underline{a}_m, \underline{\theta}_m, \omega} \right) \neq 0 \quad (6-5)$$

$$\begin{aligned} \underline{a}_m &= \hat{a} \\ \underline{\theta}_m &= \hat{\theta} \\ \omega &= \hat{\omega} \end{aligned}$$

then an oscillation exists with $(\underline{a}_m, \underline{\theta}_m, \omega) \in \Omega$.

- 2) Suppose (6-1) is satisfied for $\forall (\underline{a}_m, \underline{\theta}_m, \omega) \in \Omega$, where σ is given by (6-2) to (6-4). Then no oscillation with parameters $(\underline{a}_m, \underline{\theta}_m, \omega) \in \Omega$ exists.

Proof: The scenario for analysis rigorously defined in Theorem III applies here; the system definition is the same and hence the applicability of $| \cdot |_1$ and $| \cdot |_2$ follows. Of course, P_* is defined as the summation of harmonics greater than m , and the contractive property of x_* is obtained by the same method as before, except only harmonics greater than m are considered. Let $|x_m|_1 = A$ which is given in (6-2) and used to estimate $|x|_1$.

Applying the P^m operator to (3-4) in this case yields

$$x_m = -P^m g(x_m + x_*). \quad (6-6)$$

One adds a quantity $P^m g x_m$ to both sides and since $P^m g(\lambda |x|_1) x_* = 0$, one obtains

$$x_m + P^m g n x_m = P^m g [n x_m - n(x_m + x_*) - \frac{\lambda(|x|_1)}{2} x_*] \quad (6-7)$$

Now (6-7) actually represents m coupled complex equations. After dividing by G and taking the norm on both sides, either $\|\cdot\|_1$ or $\|\cdot\|_2$, one obtains the necessary condition for oscillation as

$$\|G^{-1}(\omega) + N(\underline{a}_m, \underline{\theta}_m)\| \|\underline{a}_m\| \leq \frac{\lambda(|x|_1)}{2} \|x_*\|$$

where the norm of a vector is evaluated as in Theorem II. Then condition 2 follows from this and the fact that $\|x_*\| \leq \frac{2\sigma}{\lambda} \|x_m\|$. If σ satisfies (6-2) through (6-4) it can be shown that it is greater than or equal to the σ of Theorem III. Hence condition 1 follows. ■

The application of Theorem V implies plotting a region in a space of dimension greater than two. This is inconvenient. A sufficient set of conditions for applying part one of the theorem is to examine a region in the (a, ω) plane given by

$$\|1/G(j\omega) + N_1(\underline{a}_m, \underline{\theta}_m)\| > \frac{\|\underline{a}_m\|}{a} \sigma \quad (6-8)$$

subject to the conditions

$$(1/G(jk\omega) + N_k(\underline{a}_m, \underline{\theta}_m)) = 0, \quad k = 3, \dots, m. \quad (6-9)$$

Suppose (6-9) is solvable for $(a_3, \dots, a_m), (\theta_3, \dots, \theta_m)$ in terms of (a, ω) (this is not always the case). It can be seen that (6-9) and (6-8) together imply (6-2). If the planar plot is bounded, then so is the multidimensional plot required by the theorem.

An example of the technique will now be discussed using the dual input describing function (DIDF). By (6-8) and (6-9), Ω is described by the relations

$$|1/G(j\omega) + N_1(a, a_3, \theta)| > \sqrt{\frac{a^2 + a_3^2}{a}} \sigma \quad (6-10)$$

$$1 + G(j3\omega) N_3(a, a_3, \theta) = 0 \quad (6-11)$$

$$A = a + a_3. \quad (6-12)$$

Continuing with the example, (6-10) and (6-11) are applied to $n(x) = x^3$ whose DIDF is

$$N_1(a, a_3, \theta) = \frac{3}{4}(a^2 + 2a_3^2 - aa_3 \cos\theta + jaa_3 \sin\theta) \quad (6-13a)$$

$$N_3(a, a_3, \theta) = \frac{3}{4}(2a^2 + a_3^2 - \frac{a^3}{3a_3} \cos\theta - j\frac{a^3}{3a_3} \sin\theta). \quad (6-13b)$$

From (6-13b) and (6-11) it is possible to find a_3 given a, ω by solving

$$\begin{aligned} a^6 - [16|1/G(j3\omega)|^2 + 36a^4 + 48a^2 \operatorname{Re}|1/G(j3\omega)|]a_3^2 \\ - (24 \operatorname{Re}|1/G(j3\omega)| + 36a^2) a_3^4 - 9a_3^6 = 0 \end{aligned} \quad (6-14)$$

and θ is obtained from

$$\theta = \sin^{-1} \left[\frac{4a_3}{a^3} \operatorname{Im}|1/G(j3\omega)| \right]. \quad (6-15)$$

Now (6-10) is plotted in the (a, ω) plane with the aid of (6-14) and the theorem is applied.

It is possible to check the non-degeneracy of a solution in this example from the relation

$$\det \begin{vmatrix} \frac{3}{2}a - \frac{3}{4}a_3 \cos\theta & 3a_3 - \frac{3}{4}a \cos\theta & \frac{3}{4}aa_3 \sin\theta & \frac{\partial \text{Re}|1/G(j\omega)|}{\partial \omega} \\ \frac{3}{4}a_3 \sin\theta & \frac{3}{4}a \sin\theta & \frac{3}{4}aa_3 \cos\theta & \frac{\partial \text{Im}|1/G(j\omega)|}{\partial \omega} \\ 3a - \frac{3}{4}\frac{a^2}{a_3} \cos\theta & \frac{3}{2}a_3 + \frac{1}{4}\frac{a^3}{a_3} \cos\theta & \frac{1}{4}\frac{a^3}{a_3} \sin\theta & \frac{\partial \text{Re}|1/G(j3\omega)|}{\partial \omega} \\ -\frac{3}{4}\frac{a^2}{a_3} \sin\theta & \frac{1}{4}\frac{a^3}{a_3} \sin\theta & -\frac{1}{4}\frac{a^3}{a_3} \cos\theta & \frac{\partial \text{Im}|1/G(j3\omega)|}{\partial \omega} \end{vmatrix} \neq 0$$

$$\begin{aligned} a &= \hat{a} \\ a_3 &= \hat{a}_3 \\ \theta &= \hat{\theta} \\ \omega &= \hat{\omega} \end{aligned}$$

(6-16)

A number of systems were analyzed using the DIDF method; each contains a cubic nonlinearity and different linear transfer functions. In each case the system was analyzed using the DF method of Theorem III, and the results compared. The (a, ω) plots are shown in Figures 6-1 through 6-4, and the results are tabulated in Figure 6-5. Note that in some cases it is possible to show oscillation with the DIDF method when the DF method is inconclusive.

B. More General Nonlinearities

Next, the nonlinearity will be generalized to a polynomial that is odd and nondecreasing. The minimum slope is required to be zero. Theorems III and IV can now be restated in the following manner.

Theorem VI: Let S satisfy (3-1) and have nonlinearity

$$n(x) = \sum_{p=3}^Q b_p x^p; \quad b_p \in \mathbb{R}, \quad n(x) \text{ odd}, \quad (6-17)$$

.05S/S2-.05S+1

1.81

2.21

OMEGA	RE 1/G(JW)	IM 1/G(JW)	IG(JW)1
.990000	-1.000000	-.402020	1.077785
.990339	-1.000000	-.388326	1.072752
.990678	-1.000000	-.374647	1.067873
.991017	-1.000000	-.360952	1.063149
.991356	-1.000000	-.347272	1.058583
.991695	-1.000000	-.333597	1.054176
.992034	-1.000000	-.319926	1.049930
.992373	-1.000000	-.306261	1.045847
.992712	-1.000000	-.292600	1.041928
.993051	-1.000000	-.278943	1.038176
.993390	-1.000000	-.265292	1.034592
.993729	-1.000000	-.251645	1.031177
.994068	-1.000000	-.238002	1.027932
.994407	-1.000000	-.224365	1.024861
.994746	-1.000000	-.210732	1.021963
.995085	-1.000000	-.197104	1.019240
.995423	-1.000000	-.183480	1.016693
.995762	-1.000000	-.169861	1.014324
.996101	-1.000000	-.156247	1.012133
.996440	-1.000000	-.142637	1.010121
.996779	-1.000000	-.129032	1.008290
.997118	-1.000000	-.115432	1.006640
.997457	-1.000000	-.101836	1.005172
.997796	-1.000000	-.088245	1.003886
.998135	-1.000000	-.074658	1.002783
.998474	-1.000000	-.061077	1.001863
.998813	-1.000000	-.047499	1.001127
.999152	-1.000000	-.033927	1.000575
.999491	-1.000000	-.020359	1.000207
.999830	-1.000000	-.006795	1.000023
1.000169	-1.000000	.006751	1.000023
1.000507	-1.000000	.020289	1.000206
1.000847	-1.000000	.033860	1.000573
1.001185	-1.000000	.047388	1.001122
1.001525	-1.000000	.060950	1.001856
1.001863	-1.000000	.074469	1.002769
1.002202	-1.000000	.087984	1.003863
1.002542	-1.000000	.101532	1.005141
1.002880	-1.000000	.115038	1.006595
1.003220	-1.000000	.128577	1.008232
1.003558	-1.000000	.142173	1.010042
1.003898	-1.000000	.155803	1.012034
1.004236	-1.000000	.169490	1.014195
1.004576	-1.000000	.182611	1.016537
1.004914	-1.000000	.196090	1.019044
1.005253	-1.000000	.209563	1.021722
1.005592	-1.000000	.223071	1.024578
1.005931	-1.000000	.236535	1.027594
1.006270	-1.000000	.250033	1.030785
1.006609	-1.000000	.263489	1.034131
1.006948	-1.000000	.276978	1.037650
1.007287	-1.000000	.290425	1.041320
1.007626	-1.000000	.303867	1.045148
1.007965	-1.000000	.317343	1.049146
1.008304	-1.000000	.330776	1.053287
1.008643	-1.000000	.344243	1.057593
1.008982	-1.000000	.357667	1.062038
1.009321	-1.000000	.371125	1.066646
1.009660	-1.000000	.384540	1.071387

FIGURE 6-1 PROOF OF OSCILLATION BY THEOREM V

$$n(x) = 1/3x^3$$

$$G(s) = \frac{.05s}{s^2 - .05s + 1}$$

1.81

.1S/S2-.1S+1
A

2.21

OMEGA	RE 1/G(JW)	IM 1/G(JW)	IG(JW)1
.990000	-1.000000	-.201011	1.020003
.990339	-1.000000	-.194164	1.018675
.990678	-1.000000	-.187319	1.017393
.991017	-1.000000	-.180477	1.016155
.991356	-1.000000	-.173637	1.014963
.991695	-1.000000	-.166799	1.013816
.992034	-1.000000	-.159964	1.012713
.992373	-1.000000	-.153131	1.011657
.992712	-1.000000	-.146301	1.010645
.993051	-1.000000	-.139472	1.009679
.993390	-1.000000	-.132646	1.008759
.993729	-1.000000	-.125823	1.007885
.994068	-1.000000	-.119002	1.007056
.994407	-1.000000	-.112183	1.006273
.994746	-1.000000	-.105366	1.005536
.995085	-1.000000	-.098552	1.004845
.995423	-1.000000	-.091740	1.004199
.995762	-1.000000	-.084931	1.003600
.996101	-1.000000	-.078124	1.003047
.996440	-1.000000	-.071319	1.002540
.996779	-1.000000	-.064516	1.002079
.997118	-1.000000	-.057716	1.001664
.997457	-1.000000	-.050918	1.001295
.997796	-1.000000	-.044123	1.000973
.998135	-1.000000	-.037329	1.000697
.998474	-1.000000	-.030538	1.000466
.998813	-1.000000	-.023750	1.000282
.999152	-1.000000	-.016964	1.000144
.999491	-1.000000	-.010179	1.000052
.999830	-1.000000	-.003398	1.000006
1.000169	-1.000000	-.003376	1.000006
1.000507	-1.000000	-.010145	1.000051
1.000847	-1.000000	-.016930	1.000143
1.001185	-1.000000	-.023694	1.000281
1.001525	-1.000000	-.030475	1.000464
1.001863	-1.000000	-.037235	1.000693
1.002202	-1.000000	-.043992	1.000967
1.002542	-1.000000	-.050766	1.001288
1.002880	-1.000000	-.057519	1.001653
1.003220	-1.000000	-.064289	1.002064
1.003558	-1.000000	-.071037	1.002520
1.003898	-1.000000	-.077802	1.003022
1.004236	-1.000000	-.084546	1.003568
1.004576	-1.000000	-.091306	1.004160
1.004914	-1.000000	-.098045	1.004795
1.005253	-1.000000	-.104782	1.005475
1.005592	-1.000000	-.111536	1.006201
1.005931	-1.000000	-.118268	1.006969
1.006270	-1.000000	-.125017	1.007784
1.006609	-1.000000	-.131745	1.008641
1.006948	-1.000000	-.138490	1.009544
1.007287	-1.000000	-.145213	1.010488
1.007626	-1.000000	-.151934	1.011476
1.007965	-1.000000	-.158672	1.012510
1.008304	-1.000000	-.165389	1.013584
1.008643	-1.000000	-.172122	1.014705
1.008982	-1.000000	-.178834	1.015865
1.009321	-1.000000	-.185563	1.017071
1.009660	-1.000000	-.192271	1.018316

FIGURE 6-2 PROOF OF OSCILLATION BY THEOREM V

$$n(x) = 1/3x^3$$

$$G(s) = \frac{.1s}{s^2 - .1s + 1}$$

1.71

S-1/S4+S3-12S2-12
A

2.31

OMEGA	RE 1/G(JW)	IM 1/G(JW)	IG(JW) 1
.980000	-.698660	.256564	.744222
.980678	-.708862	.247981	.750986
.981356	-.719121	.239390	.757920
.982034	-.729377	.230791	.765020
.982712	-.739631	.222183	.772282
.983390	-.749881	.213567	.779700
.984068	-.760127	.204944	.787271
.984746	-.770370	.196313	.794990
.985424	-.780611	.187673	.802854
.986102	-.790848	.179026	.810858
.986780	-.801081	.170370	.818997
.987457	-.811311	.161707	.827270
.988135	-.821539	.153035	.835671
.988813	-.831763	.144356	.844197
.989491	-.841984	.135669	.852844
.990169	-.852201	.126974	.861608
.990847	-.862416	.118270	.870488
.991525	-.872627	.109559	.879478
.992203	-.882835	.100840	.888575
.992881	-.893039	.092113	.897777
.993559	-.903242	.083378	.907082
.994237	-.913440	.074635	.916484
.994915	-.923635	.065885	.925981
.995593	-.933826	.057126	.935572
.996271	-.944016	.048359	.945253
.996949	-.954201	.039585	.955022
.997627	-.964383	.030803	.964875
.998305	-.974562	.022013	.974810
.998983	-.984738	.013215	.984827
.999661	-.994911	.004410	.994920
1.000339	-1.005078	-.004402	1.005088
1.001017	-1.015246	-.013225	1.015332
1.001694	-1.025396	-.022043	1.025633
1.002372	-1.035557	-.030861	1.036017
1.003050	-1.045715	-.039727	1.046470
1.003728	-1.055870	-.048581	1.056987
1.004406	-1.066022	-.057442	1.067568
1.005084	-1.076170	-.066312	1.078211
1.005762	-1.086315	-.075189	1.088914
1.006440	-1.096457	-.084073	1.099676
1.007118	-1.106596	-.092966	1.110494
1.007795	-1.116717	-.101854	1.121353
1.008473	-1.126850	-.110762	1.132280
1.009151	-1.136979	-.119677	1.143260
1.009830	-1.147105	-.128601	1.154291
1.010508	-1.157227	-.137532	1.165371
1.011186	-1.167347	-.146471	1.176500
1.011864	-1.177463	-.155417	1.187676
1.012542	-1.187576	-.164371	1.198897
1.013220	-1.197686	-.173333	1.210164
1.013897	-1.207778	-.182290	1.221457
1.014575	-1.217882	-.191267	1.232809
1.015253	-1.227982	-.200252	1.244203
1.015931	-1.238079	-.209244	1.255636
1.016609	-1.248173	-.218244	1.267109
1.017287	-1.258263	-.227252	1.278620
1.017965	-1.268350	-.236267	1.290168
1.018643	-1.278434	-.245289	1.301753
1.019321	-1.288515	-.254320	1.313374

FIGURE 6-3 PROOF OF OSCILLATION BY THEOREM V

$$n(x) = 1/3x^3$$

$$G(s) = \frac{s - 1}{s^4 + s^3 - 12s^2 - 12}$$

1.85

.0982/S4-.6S3+1.91S2-.6S+1
A

2.17

OMEGA	RE 1/G(JW)	IM 1/G(JW)	IG(JW)1
1	.990000	-1.000475	.134007
1	.990339	-1.0004174	.129442
1	.990678	-1.0003804	.124879
1	.991017	-1.0003605	.120317
1	.991356	-1.0003335	.115757
1	.991695	-1.0003077	.111199
1	.992034	-1.0002829	.106642
1	.992373	-1.0002591	.102087
1	.992712	-1.0002364	.097533
1	.993051	-1.0002147	.092981
1	.993390	-1.0001940	.088431
1	.993729	-1.0001744	.083882
1	.994068	-1.0001559	.079334
1	.994407	-1.0001384	.074788
1	.994746	-1.0001219	.070244
1	.995085	-1.0001065	.065701
1	.995423	-1.0000921	.061160
1	.995762	-1.0000787	.056620
1	.996101	-1.0000664	.052082
1	.996440	-1.0000551	.047546
1	.996779	-1.0000448	.043011
1	.997118	-1.0000356	.038477
1	.997457	-1.0000274	.033945
1	.997796	-1.000202	.029415
1	.998135	-1.000140	.024886
1	.998474	-1.000089	.020359
1	.998813	-1.000048	.015833
1	.999152	-1.000017	.011309
1	.999491	-.999997	.006786
1	.999830	-.999987	.002265
1	1.000169	-.999987	-.002250
1	1.000507	-.999997	-.006763
1	1.000847	-1.000017	-.011287
1	1.001185	-1.000048	-.015796
1	1.001525	-1.000089	-.020317
1	1.001863	-1.000139	-.024823
1	1.002202	-1.000200	-.029328
1	1.002542	-1.000272	-.033844
1	1.002880	-1.000353	-.038366
1	1.003220	-1.000445	-.042859
1	1.003558	-1.000546	-.047358
1	1.003898	-1.000658	-.051868
1	1.004236	-1.000780	-.056364
1	1.004576	-1.000912	-.060870
1	1.004914	-1.001054	-.065363
1	1.005253	-1.001205	-.069855
1	1.005592	-1.001368	-.074357
1	1.005931	-1.001540	-.078845
1	1.006270	-1.001722	-.083345
1	1.006609	-1.001914	-.087830
1	1.006948	-1.002116	-.092326
1	1.007287	-1.002328	-.096808
1	1.007626	-1.002550	-.101289
1	1.007965	-1.002783	-.105781
1	1.008304	-1.003025	-.110259
1	1.008643	-1.003277	-.114748
1	1.008982	-1.003539	-.119222
1	1.009321	-1.003811	-.123708
1	1.009660	-1.004093	-.128180
1	.990000	-1.000475	.1013374
1	.990339	-1.0004174	.1012483
1	.990678	-1.0003804	.1011622
1	.991017	-1.0003605	.1010791
1	.991356	-1.0003335	.1009991
1	.991695	-1.0003077	.1009222
1	.992034	-1.0002829	.1008483
1	.992373	-1.0002591	.1007775
1	.992712	-1.0002364	.1007098
1	.993051	-1.0002147	.1006451
1	.993390	-1.0001940	.1005835
1	.993729	-1.0001744	.1005250
1	.994068	-1.0001559	.1004696
1	.994407	-1.0001384	.1004173
1	.994746	-1.0001219	.1003680
1	.995085	-1.0001065	.1003218
1	.995423	-1.0000921	.1002787
1	.995762	-1.0000787	.1002387
1	.996101	-1.0000664	.1002018
1	.996440	-1.0000551	.1001680
1	.996779	-1.0000448	.1001372
1	.997118	-1.0000356	.1001095
1	.997457	-1.0000274	.1000849
1	.997796	-1.000202	.1000634
1	.998135	-1.000140	.1000450
1	.998474	-1.000089	.1000296
1	.998813	-1.000048	.1000173
1	.999152	-1.000017	.1000081
1	.999491	-.999997	.1000020
1	.999830	-.999987	.999989
1	1.000169	-.999987	.999989
1	1.000507	-.999997	.1000020
1	1.000847	-1.000017	.1000081
1	1.001185	-1.000048	.1000173
1	1.001525	-1.000089	.1000295
1	1.001863	-1.000139	.1000447
1	1.002202	-1.000200	.1000630
1	1.002542	-1.000272	.1000844
1	1.002880	-1.000353	.1001088
1	1.003220	-1.000445	.1001362
1	1.003558	-1.000546	.1001666
1	1.003898	-1.000658	.1002001
1	1.004236	-1.000780	.1002366
1	1.004576	-1.000912	.1002761
1	1.004914	-1.001054	.1003185
1	1.005253	-1.001205	.1003639
1	1.005592	-1.001368	.1004125
1	1.005931	-1.001540	.1004638
1	1.006270	-1.001722	.1005183
1	1.006609	-1.001914	.1005756
1	1.006948	-1.002116	.1006361
1	1.007287	-1.002328	.1006993
1	1.007626	-1.002550	.1007654
1	1.007965	-1.002783	.1008347
1	1.008304	-1.003025	.1009067
1	1.008643	-1.003277	.1009818
1	1.008982	-1.003539	.1010596
1	1.009321	-1.003811	.1011405
1	1.009660	-1.004093	.1012242

FIGURE 6-4 PROOF OF OSCILLATION BY THEOREM V

$$n(x) = 1/3x^3$$

$$G(s) = \frac{.09s^2}{s^4 - .6s^3 + 1.91s^2 - .6s + 1}$$

$G(s)$	Ω DF METHOD	Ω DIDF METHOD
$\frac{.05s}{s^2 - .05s + 1}$	$1.93 < a < 2.12$ $.9977 < \omega < 1.0022$	$1.96 < a < 2.07$ $.9988 < \omega < 1.0008$
$\frac{.1s}{s^2 - .1s + 1}$	-	$1.93 < a < 2.17$ $.9937 < \omega < 1.0055$
$\frac{s - 1}{s^4 + s^3 - 12s^2 - 12}$	$1.90 < a < 2.20$ $.9949 < \omega < 1.0084$	$1.99 < a < 2.02$ $.998 < \omega < 1.0016$
$\frac{.09s^2}{s^4 - .6s^3 + 1.91s^2 - .6s + 1}$	$1.96 < a < 2.06$ $.9957 < \omega < 1.0042$	$1.99 < a < 2.02$ $.9988 < \omega < 1.0011$

FIGURE 6-5

A Comparison of Ω for $n(x) = 1/3x^3$ when
 Computed by DF Method (Theorem III)
 and DIDF Method (Theorem V)

with $0 < \frac{dn}{dx} < \infty$. Let Ω be a disc in $(\underline{a}_m, \underline{\theta}_m, \omega)$ space.

- 1) Suppose there is an MIDF solution $(\hat{\underline{a}}_m, \hat{\underline{\theta}}_m, \omega) \in \Omega$
and on $\partial\Omega$

$$||(\underline{G}^{-1}(\omega) + \underline{N}(\underline{a}_m, \underline{\theta}_m)) \underline{a}_m|| > ||\underline{a}_m|| \sigma \quad (6-1)$$

where σ satisfies

$$A = \sum_{k=1}^m a_k;$$

$$x_s = (1 + \frac{2\sigma}{\lambda}) A \quad (6-18)$$

$$\lambda \geq \max_{x < x_s} \left| \sum_{p=3}^Q p b_p x^p - 1 \right|, \quad \lambda \geq \sum_{p=3}^Q |b_p| x_s^{p-1} \quad (6-19)$$

$$\frac{2\sigma}{\lambda} = \frac{\lambda}{\inf_{k > m} \left| \frac{2}{G(jk\omega)} + \lambda \right| \lambda} \quad (6-20)$$

and

$$J \left(\frac{[1 + \underline{G}(\omega) \underline{N}(\underline{a}_m, \underline{\theta}_m)] \underline{a}_m}{\underline{a}_m, \underline{\theta}_m, \omega} \right) \neq 0 \quad \begin{aligned} \underline{a}_m &= \hat{\underline{a}} \\ \underline{\theta}_m &= \hat{\underline{\theta}} \\ \omega &= \hat{\omega} \end{aligned} \quad (6-5)$$

then an oscillation exists with $(\underline{a}_m, \underline{\theta}_m, \omega) \in \Omega$.

- 2) Suppose (6-1) is satisfied for $\forall (\underline{a}_m, \underline{\theta}_m, \omega) \in \Omega$,
where σ is given by (6-18) to (6-20). Then no
oscillation exists with parameters $(\underline{a}, \underline{\theta}, \omega) \in \Omega$.

Proof: The proof is the same as Theorem V except it must be shown that λ satisfies (4-5) and (4-12). Since

$$|x|_5 \leq |x|_7 \leq \left(1 + \frac{2\sigma}{\lambda}\right) A$$

and, from (6-17) one obtains

$$\frac{dn}{dx} = \sum_{p=3}^Q pb_p x^{p-1}.$$

Hence it follows that $\lambda \geq \frac{dn}{dx}$. Now relate $|n(x)|_7$ to $|x|_7$. Noting that $|x^p|_7 \leq (|x|_7)^p$, it is seen that, from the triangle inequality,

$$|n(x)|_7 = \left| \sum_{p=3}^Q b_p x^p \right|_7 \leq \sum_{p=3}^Q |b_p| |x|_7^p. \quad (6-21)$$

Hence (4-12) is satisfied also. ■

Two special cases are worth mentioning. When $b_p > 0$, $n(x)$ is slope monotonic, and (6-19) may be written

$$\lambda = \sum_{p=3}^Q pb_p \left(1 + \frac{2\sigma}{\lambda}\right)^{p-1} A^{p-1}. \quad (6-22)$$

The theorem requires $\frac{dn}{dx}$ to be in the range $[0, \infty]$. When finding a bound on $||x_*||$, a pole shifting technique was used to sharpen the results. The median slope was required, and the minimum slope was set equal to zero. Rather than restate the results, when $\frac{dn}{dx} \in [\alpha, \infty]$ or $\frac{dn}{dx} \in [-\infty, \alpha]$, the system may be rearranged to meet the requirements. In the latter case, multiply $n(x)$ and $G(s)$ by -1 so $\frac{dn}{dx} \in [\alpha, \infty]$. A new function, $n'(x)$, is constructed so that

$$n'(x) = n(x) - \alpha x \quad (6-23)$$

and a linear function, g' , is obtained from

$$G'(s) = \frac{G(s)}{1 + \alpha G(s)}. \quad (6-24)$$

The transformation is shown diagrammatically in Figure 6-6, and it can be seen that the two systems are equivalent.

One may apply Theorem IV to systems whose nonlinear elements satisfy (6-17) with $b_p > 0$. To do so requires the following theorem.

Theorem VII: Let S satisfy (3-1) and have nonlinearity

$$n(x) = \sum_{\substack{p=3 \\ p \text{ odd}}}^Q b_p x^p; \quad b_p > 0. \quad (6-25)$$

If S has a DF solution and if Theorem IV predicts oscillation for a system S' in a region Ω' whose linear element g' is the same as g and whose nonlinear element is

$$n'(x) = x^Q$$

then S has an oscillation with (N, ω) in Ω' .

Proof: Define two quantities, c_2' and c_2'' , which are solutions to the equations

$$c_2' = \max_{(a, \omega) \in \Omega'} \left| \frac{\sum_{p=3}^Q b_p \alpha_p (c_2')^p a^{p-1}}{\sum_{p=3}^Q b_p \beta_p a^{p-1}} \right| \quad (6-26)$$

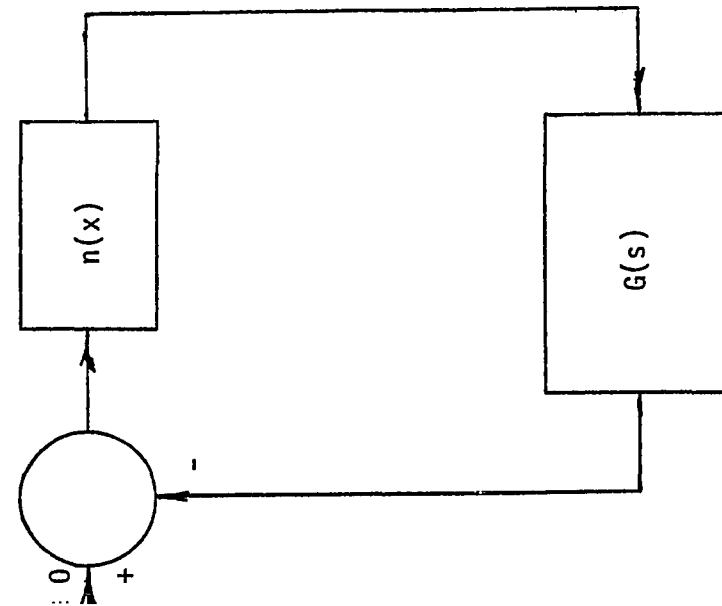
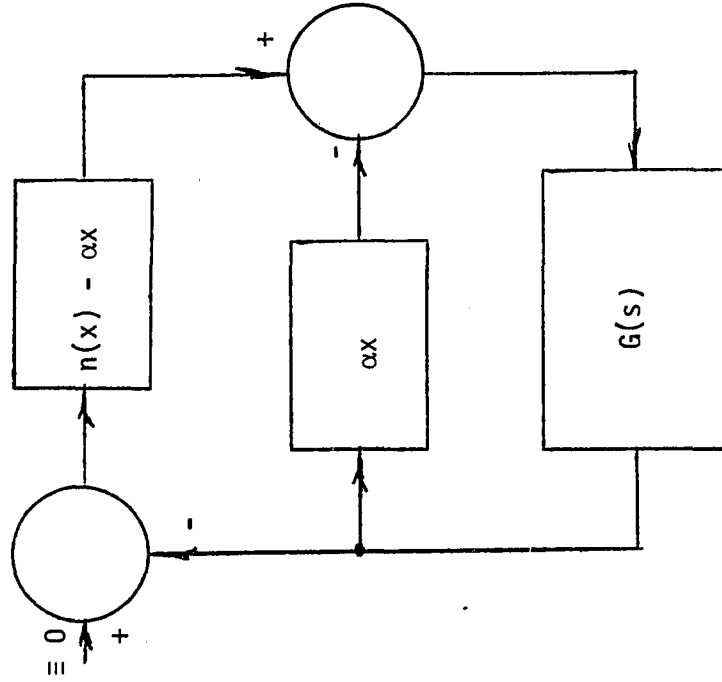
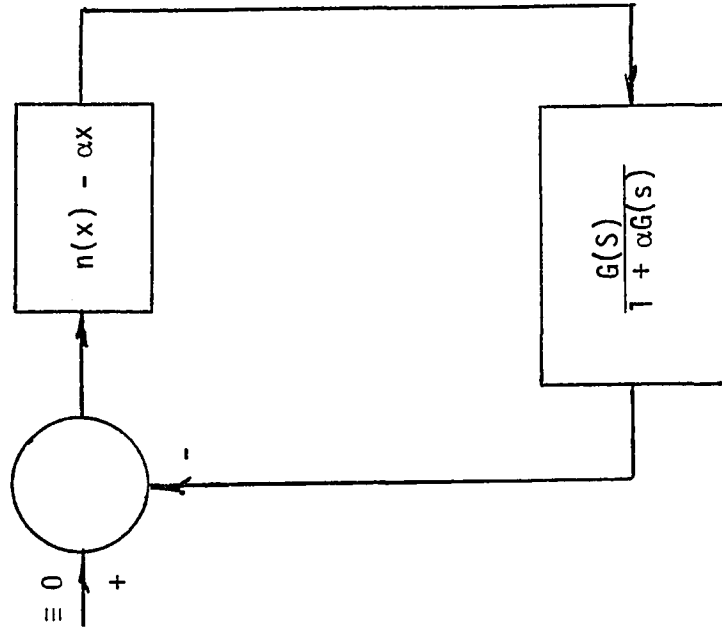

FIGURE 6-6 TRANSFORMING THE SYSTEM TO HAVE A MINIMUM SLOPE OF ZERO

$$c_2'' = \frac{\alpha_Q(c_2'')}{\beta_Q} \quad (6-27)$$

where

$$\alpha_p(c_2) = P(1 + 1/c_2)^{p-1} \quad (6-28)$$

$$\beta_p = \frac{N(a)}{a^{p-1}} = \frac{p}{(p+1)} \frac{(p-2)}{(p-1)} \cdots \frac{3}{4} \cdot \quad (6-29)$$

It will be shown that $c_2'' > c_2'$; it is sufficient to show that, for all c_2

$$\frac{\alpha_Q(c_2)}{\beta_Q} > \frac{\sum_{p=3}^Q b_p \alpha_p(c_2) a^{p-1}}{\sum_{p=3}^Q b_p \beta_p a^{p-1}}, \quad \forall(a, \omega) \in \Omega. \quad (6-30)$$

Now

$$\frac{\alpha_p}{\beta_p} = (p+1) \frac{(p-1)}{(p-2)} \cdots \frac{3}{4} (1 + 1/c_2)^{p-1} > 0 \quad (6-31)$$

from (6-28) and (6-29), and examining (6-31) one finds that for any c_2

$$\frac{\alpha_{p+1}}{\beta_{p+1}} > \frac{\alpha_p}{\beta_p}, \quad I > 0.$$

Since $a^{p-1} > 0$, this leads to

$$\alpha_{p+1} \beta_p a^{p-1} > \alpha_p \beta_{p+1} a^{p-1} \quad (6-32)$$

which may be used to form the sum of terms

$$\sum_{\substack{p=3 \\ p \text{ odd}}}^Q b_p \alpha_Q \beta_p a^{p-1} > \sum_{\substack{p=3 \\ p \text{ odd}}}^Q b_p \beta_Q \alpha_p a^{p-1}. \quad (6-33)$$

On dividing both sides by $\beta_Q \sum_{\substack{p=3 \\ p \text{ odd}}}^Q b_p \beta_p a^{p-1}$, (6-30) follows.

From (5-12), one sees that for the system S' , one may write

$$N(a) c_2'' \geq \lambda \quad (6-34)$$

while from (6-22) and (5-11) one sees for the system S that

$$N(a) c_2' \geq \lambda. \quad (6-35)$$

But $c_2'' > c_2'$; hence for S , equation (6-34) also holds. Then applying Theorem IV with (5-3) replaced by (6-27) yields a region Ω' in the (N, ω) plane for the system S ; however, this is equivalent to applying Theorem IV to S' . ■

The use of Theorem VI is illustrated in Figure 6-7.

1.90

3-1/24733-1402-10V
A

2.10

OMEGA	RE 1/G(JW)	IM 1/G(JW)	IG(JW)1
.997000	-.510299	.482259	.702124
.997102	-.526911	.465947	.703378
.997203	-.543530	.449623	.705398
.997305	-.560148	.433298	.708176
.997407	-.576765	.416971	.711704
.997508	-.593379	.400643	.715970
.997610	-.609993	.384312	.720963
.997712	-.626604	.367980	.726665
.997813	-.643214	.351647	.733062
.997915	-.659823	.335311	.740135
.998017	-.676429	.318974	.747865
.998118	-.693035	.302635	.756231
.998220	-.709638	.286295	.765213
.998322	-.726240	.269952	.774790
.998424	-.742841	.253608	.784939
.998525	-.759439	.237263	.795639
.998627	-.776037	.220915	.806868
.998729	-.792632	.204566	.818604
.998830	-.809226	.188215	.830826
.998932	-.825819	.171863	.843512
.999034	-.842409	.155508	.856642
.999135	-.858998	.139152	.870196
.999237	-.875586	.122795	.884155
.999339	-.892172	.106435	.898498
.999440	-.908756	.090074	.913209
.999542	-.925339	.073711	.928270
.999644	-.941920	.057347	.943664
.999745	-.958500	.040981	.959375
.999847	-.975078	.024613	.975388
.999949	-.991654	.008243	.991688
1.000050	-1.008083	-.007984	1.008115
1.000152	-1.024715	-.024415	1.025005
1.000254	-1.041344	-.040847	1.042145
1.000355	-1.057817	-.057128	1.059359
1.000457	-1.074444	-.073564	1.076959
1.000559	-1.091069	-.090001	1.094775
1.000660	-1.107537	-.106287	1.112625
1.000762	-1.124159	-.122728	1.130838
1.000863	-1.140624	-.139017	1.149064
1.000965	-1.157242	-.155461	1.167638
1.001067	-1.173859	-.171907	1.186380
1.001168	-1.190319	-.188201	1.205105
1.001270	-1.206933	-.204650	1.224160
1.001372	-1.223545	-.221101	1.243362
1.001473	-1.240000	-.237401	1.262521
1.001575	-1.256609	-.253855	1.281994
1.001677	-1.273061	-.270158	1.301411
1.001779	-1.289667	-.286616	1.321132
1.001881	-1.306271	-.303075	1.340969
1.001982	-1.322718	-.319383	1.360731
1.002084	-1.339319	-.335846	1.380786
1.002186	-1.355919	-.352311	1.400942
1.002287	-1.372361	-.368623	1.421006
1.002389	-1.388957	-.385091	1.441353
1.002490	-1.405397	-.401407	1.461598
1.002592	-1.421989	-.417879	1.482119
1.002694	-1.438581	-.434352	1.502723
1.002795	-1.455015	-.450673	1.523212
1.002897	-1.471603	-.467150	1.543971

FIGURE 6-7 PROOF OF OSCILLATION BY THEOREM VI

$$n(x) = .00571x^7 + .02x^5 + .2x^3$$

$$G(s) = \frac{s - 1}{s^4 + s^3 - 160s^2 - 160}$$

CHAPTER VII

SYSTEMS CONTAINING APPROXIMATELY DISCONTINUOUS NONLINEAR FUNCTIONS

Many cases of nonlinear systems can best be modeled as discontinuous. A simple example is the ideal relay shown in Figure 7-1.

However, a differential equation that is discontinuous need not have a unique solution. For the purposes of this analysis, the ideal relay may be approximated arbitrarily closely by a limiter as shown in Figure 7-2. From the figure, the gain about the point $x = 0$ is A/ϵ ; note that the ideal relay is the limit as $\epsilon \rightarrow 0$ of the limiter.

Definition: $n(x) \in J_\epsilon$ if $\frac{dn}{dx}$ is zero except on finitely many intervals of the form $(x_0 - \epsilon, x_0 + \epsilon)$. The points of discontinuity of $\frac{dn}{dx}$ are finite jump discontinuities which occur in pairs with distance between pairs 2ϵ .

Step functions occur naturally as limits n_ϵ as $\epsilon \rightarrow 0$ with $n_\epsilon \in J_\epsilon$. It is convenient to represent n_ϵ for very small $\epsilon \rightarrow 0$ by its limit. Two other important functions that are limits as $\epsilon \rightarrow 0$ of $n_\epsilon \in J_\epsilon$ are a relay with deadzone and a staircase function, shown in Figure 7-3 and 7-4.

The analysis that follows deals with a single input describing function approach. This is similar to work done by Blackmore [15], although the scope of the system and the method of proof differ.

It is convenient to define a function Γ which will be used extensively in the work that follows

Definition: Let Γ be a function of three real numbers, a, b, c , such that

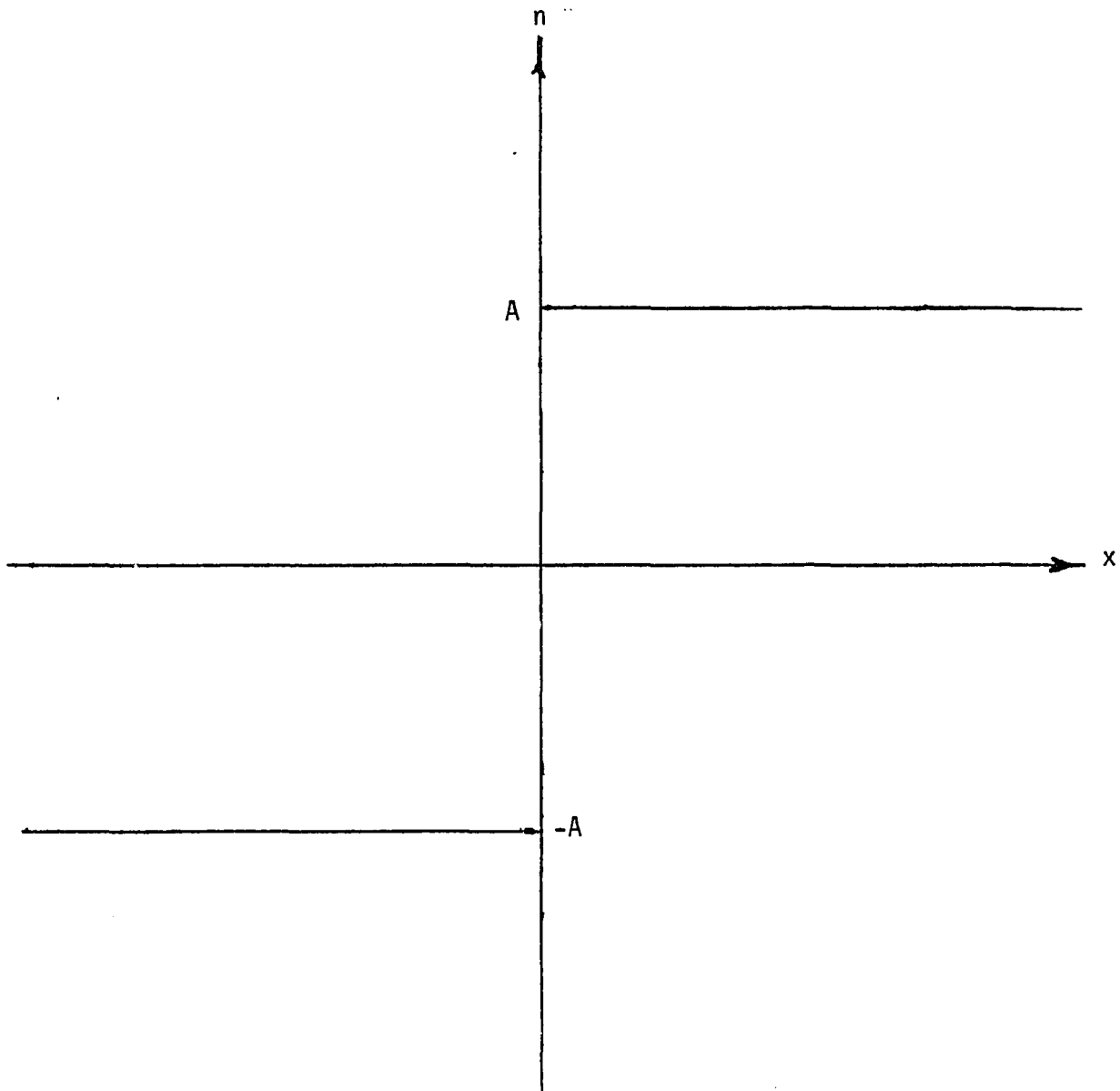

FIGURE 7-1 IDEAL RELAY

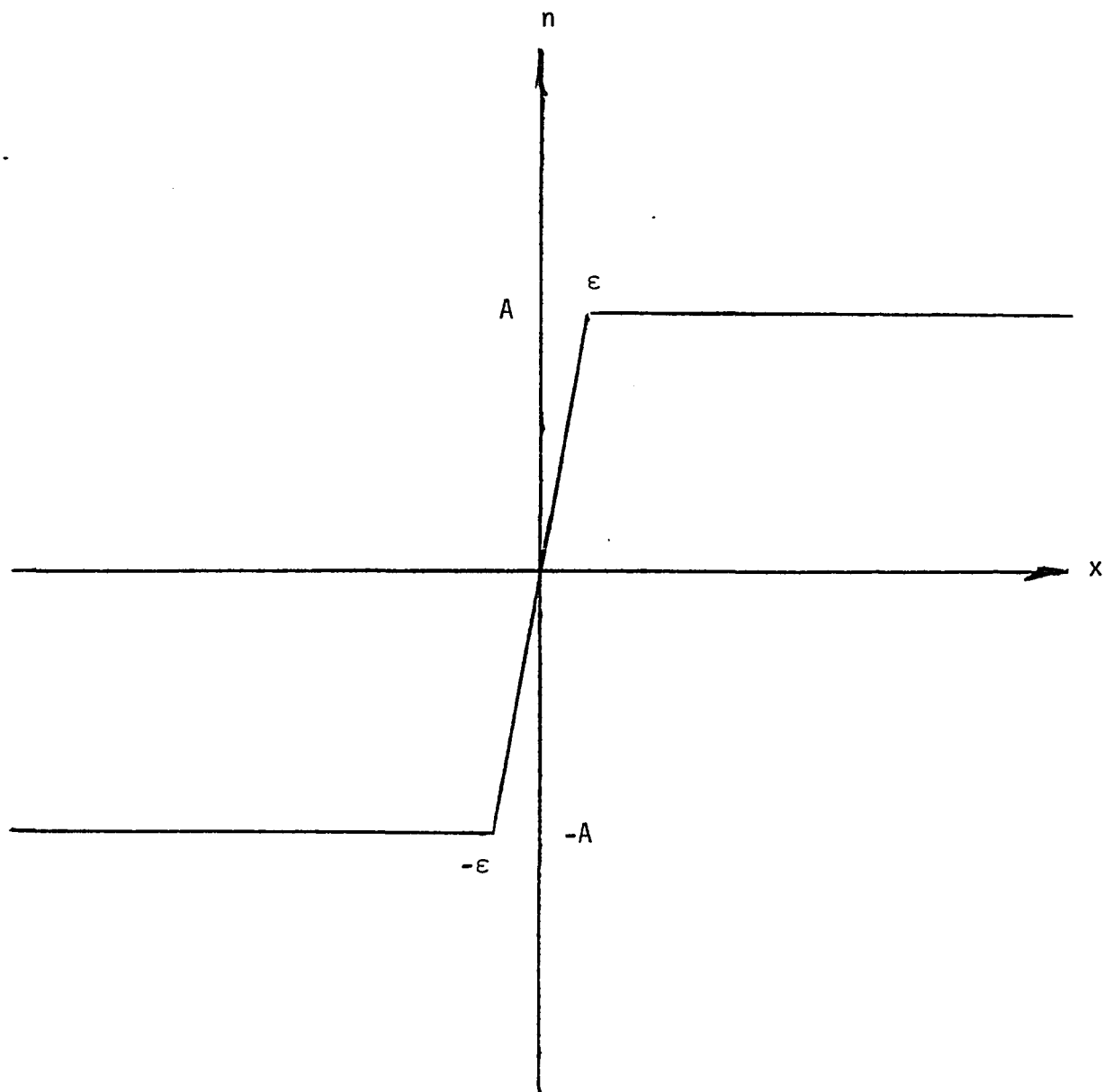

FIGURE 7-2 LIMITER WITH HIGH GAIN

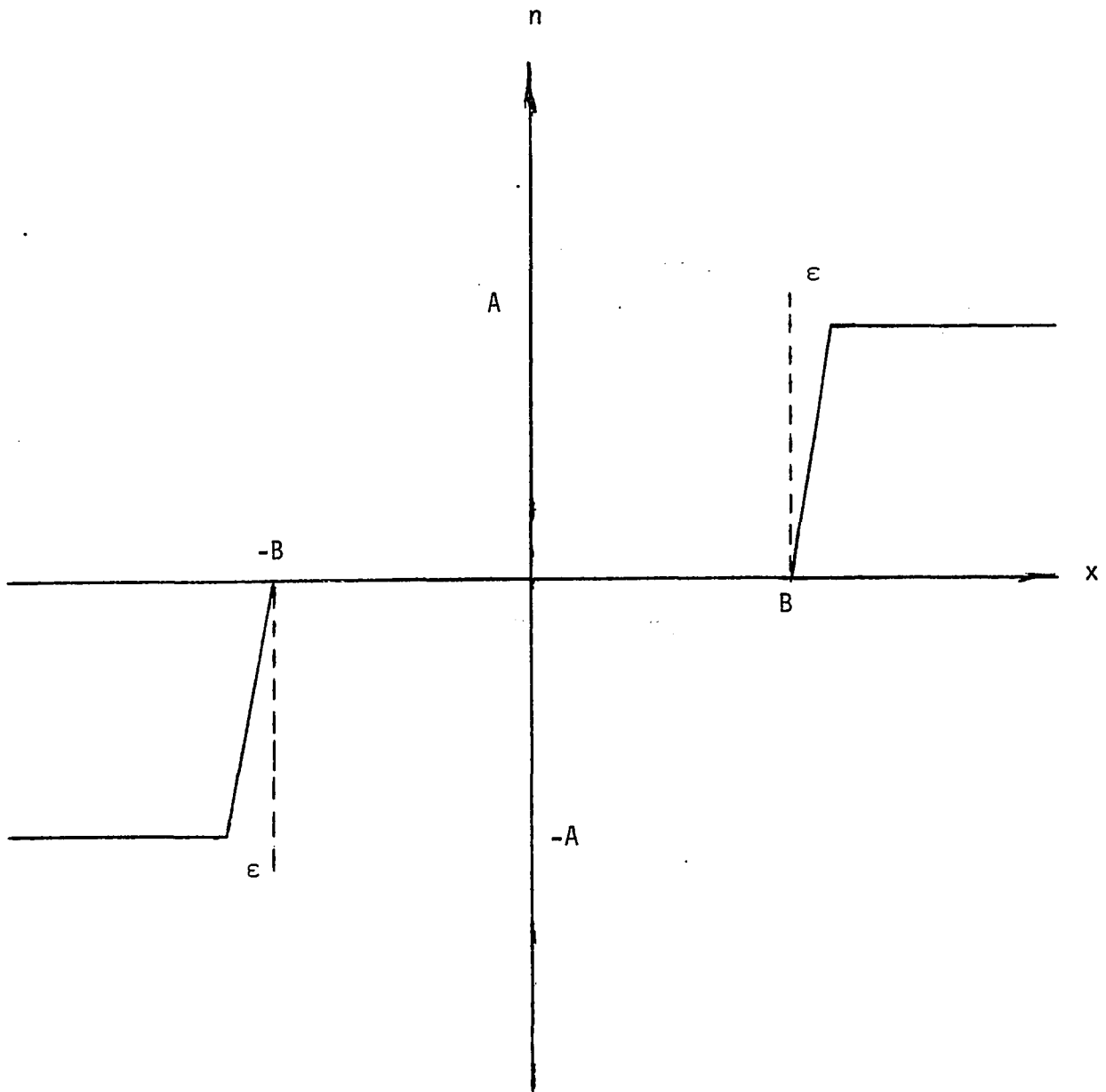

FIGURE 7-3 RELAY WITH DEADZONE

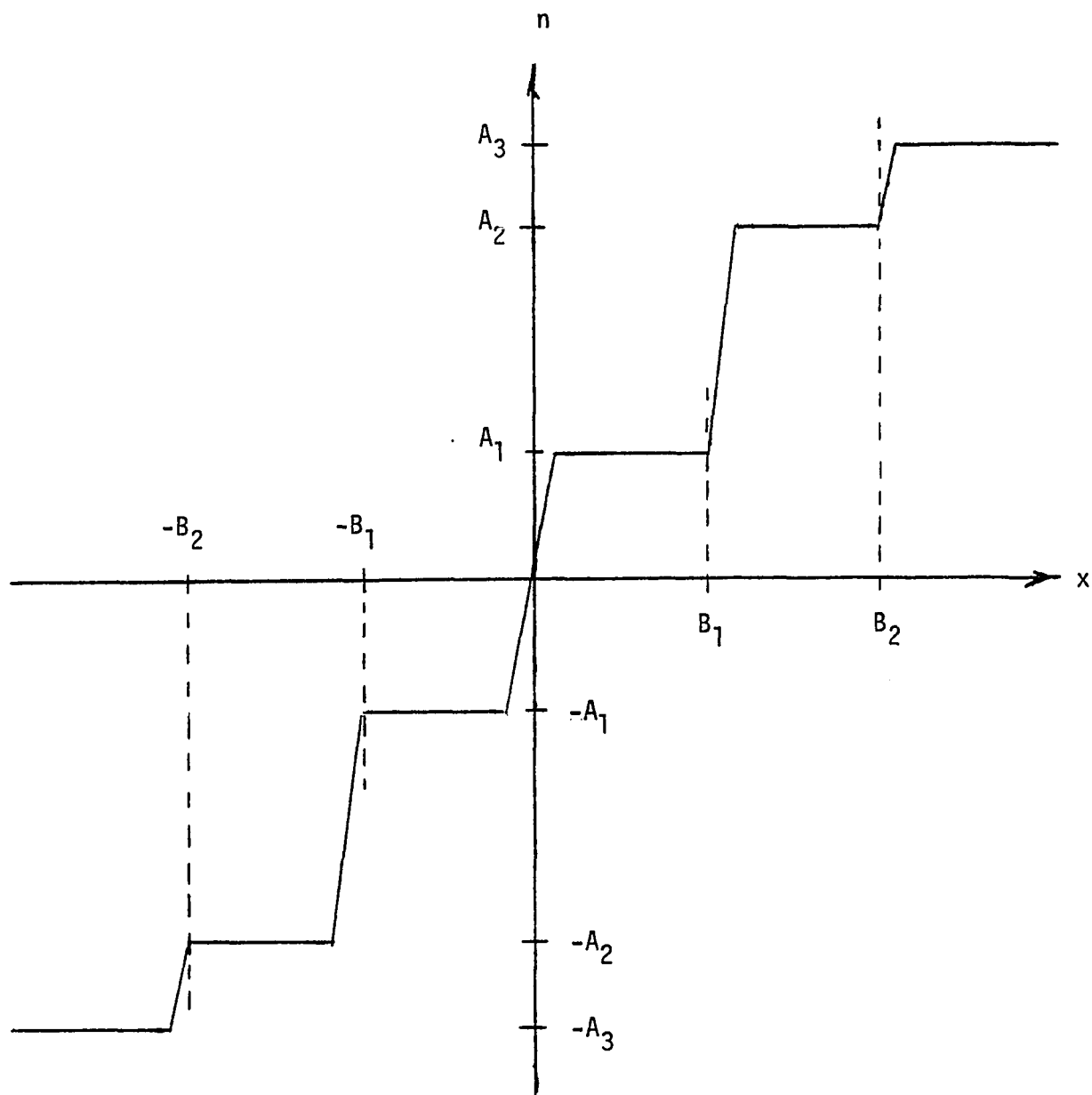

FIGURE 7-4 STAIRCASE FUNCTION

$$\Gamma(a, b, c) = \begin{cases} 0 & (b + c) > a \\ \sqrt{1 - \left(\frac{b+c}{a}\right)^2} & 0 < (b+c) \leq a \\ 1 & (b+c) \leq 0 \end{cases} \quad (7-1)$$

The first theorem in this section deals with some special functions belonging to J_ϵ .

Theorem VIII: Let S contain $n(x) \in J_\epsilon$ represented by one of the following:

a) Ideal Relay

$$\lim_{\epsilon \rightarrow 0} n_\epsilon(x) = \begin{cases} A & x > 0 \\ -A & x < 0 \end{cases}$$

b) Relay with Deadzone

$$\lim_{\epsilon \rightarrow 0} n_\epsilon(x) = \begin{cases} A & x > B \\ 0 & -B < x < B \\ -A & x < -B \end{cases}$$

c) Staircase Function

$$\lim_{\epsilon \rightarrow 0} n_\epsilon(x) = \begin{cases} A_i, & B_i < x < B_i + 1 \\ -A_i, & -B_i + 1 < x < -B_i \\ i = 1, \dots, k. \end{cases}$$

and suppose ϵ is sufficiently small (determined in the proof).

1) Suppose there is a DF solution $(\hat{a}, \hat{\omega}) \in \Omega$ where Ω is a disc in (a, ω) and on $\partial\Omega$

$$|1/G(j\omega) + N(a)| > \sigma(a, x_h) \quad (7-2)$$

where $x_h(a, \omega)$ satisfies

$$y_h = n (a + y_h) \sqrt{\sum_{|k| > 3} |G(jk\omega)|^2}; \quad x_h = y_h + \epsilon \quad (7-3)$$

and, for the functions mentioned σ is given as follows:

a) Ideal Relay

$$\sigma(a, x_h) = \frac{4A}{\pi a} [1 - \Gamma(a, x_h, 0)] \quad (7-4)$$

b) Relay with Deadzone

$$\sigma(a, x_h) = \frac{4A}{\pi a} [\Gamma(a, B, -x_h) - \Gamma(a, B, x_h)] \quad (7-5)$$

c) Staircase Function

$$\sigma(a, x_h) = \frac{4}{\pi a} \sum_{i=1}^k (A_i - A_{i-1}) [\Gamma(a, B_i, -x_h) - \Gamma(a, B_i, x_h)] \text{ with } A_0 = 0. \quad (7-6)$$

In addition, Let

$$\sum_{|k| > 3}^{\infty} |G(jk\omega)| < \infty \quad (7-7)$$

-and

$$\left| \frac{\frac{2\alpha}{\pi a} \sum_{|k| > 3} |G(jk\omega)|}{\sqrt{1 - \left(\frac{\beta + x_h}{a}\right)^2}} \right| < 1, \quad \forall(a, \omega) \in \Omega \quad (7-8)$$

where for

- a) Ideal Relay $\alpha = A, \beta = 0$
 b) Relay with Deadzone $\alpha = A, \beta = B$
 c) Staircase Function $\alpha = A_i, \beta = B_i$
 $i = \min \{j | a - B_j > 0\} .$

Then an oscillation exists with $(a, \omega) \in \Omega$.

- 2) If, for all points within a disc Ω in (a, ω) (7-7) is satisfied and (7-2) is satisfied, then no oscillation can exist having (a, ω) in Ω .

Proof: The analysis will be done in the Hilbert space of L_2 functions; however, the $\|\cdot\|_1$ norm is also used. Note that $\|n_\epsilon(x)\|_1$ may not be bounded, independent of ϵ . Employing the usual orthogonal projections, the system can be represented by

$$x_* = -P_*^1 g n_\epsilon(x_1 + x_*) \quad (7-9)$$

$$x_1 + P^1 g n_\epsilon x_1 = P^1 g [n_\epsilon x_1 - n_\epsilon(x_1 + x_*)]. \quad (7-10)$$

If x is a solution of (3-4), then $\|x_*\|_1$ is bounded; to see this proceed as follows. Representing $n(x)$ by a Fourier series one obtains

$$y = n(x) = \sum_{k=-\infty}^{\infty} B_k e^{jk\omega t}, \quad B_k \in \mathbb{C} \quad (7-11)$$

which, when passed through g becomes

$$x = \sum_{k=-\infty}^{\infty} C_k e^{jk\omega t} = -g n_\epsilon x = \sum_{k=-\infty}^{\infty} g(jk\omega) B_k e^{jk\omega t} . \quad (7-12)$$

Applying P_* to both sides and taking absolute values of each term of the sum yields

$$\sum_{|k| > 3} |c_k| = \sum_{|k| > 3} |g(jk\omega) B_k| \quad (7-13)$$

which, from the Cauchy-Schwarz inequality, becomes

$$\sum_{|k| > 3} |c_k| \leq \left(\sum_{|k| > 3} |g(jk\omega)|^2 \right)^{1/2} \left(\sum_{k=-\infty}^{\infty} |B_k|^2 \right)^{1/2}. \quad (7-14)$$

Since n_ϵ is bounded and continuous, $\left(\sum_{k=-\infty}^{\infty} |B_k|^2 \right)^{1/2} < \infty$. Let

$\tau = 2\pi/\omega$ be the assumed period of oscillation and

$$\alpha = |n_\epsilon(x)|_s \quad (7-15)$$

then from Parseval's theorem

$$\sum_{k=-\infty}^{\infty} |B_k|^2 = \frac{1}{\tau} \int_0^\tau [n(x)]^2 dt \leq \alpha^2. \quad (7-16)$$

All three functions considered are nondecreasing; hence

$$\begin{aligned} |n_\epsilon(x)|_s &\leq n_\epsilon(x_s) \leq n_\epsilon(|x|_1) \leq n_\epsilon(|x|_1 + |x_*|_1) \\ &\leq n(a+b) \end{aligned} \quad (7-17)$$

for any $b \geq |x_*|_1$. Then from (7-3), (7-14), (7-16), and (7-17) it follows that one can set $b = x_h$.

That (7-9) can be solved for x_* as a unique function of (a, ω) may be shown by investigating the contractive properties of (7-9). Take two

points, x_{*}' and x_{*}'' , with the metric $|x_{*}'' - x_{*}'|_1$. Substituting, one obtains

$$|[P_{*}^1 g n_{\epsilon}(x_1 + x_{*}'')] - [P_{*}^1 g n_{\epsilon}(x_1 + x_{*}')]]|_1 \leq |P_{*}^1 G(jk\omega)|_1 F \quad (7-18)$$

where

$$F = \sup_{|k| > 1} \left| \frac{1}{2\pi} \int_0^{2\pi} [n_{\epsilon}(x_1 + x_{*}'') - n_{\epsilon}(x_1 + x_{*}')] e^{jk\theta} d\theta \right|. \quad (7-19)$$

It is easy to see that

$$|P_{*}^1 G(jk\omega)|_1 = \sum_{|k| > 3} |G(jk\omega)| \quad (7-20)$$

and

$$F \leq \left| \frac{1}{2\pi} \int_0^{2\pi} |n(x_1 + x_{*}'') - n(x_1 + x_{*}')| d\theta \right|. \quad (7-21)$$

The integral on the right side of (7-21) can be estimated when $|x_{*}|_s \ll |x_1|_s$. Let the nonlinearity be represented in its limit (as $\epsilon \rightarrow 0$) by a jump of magnitude α at an input of β (with a symmetrical jump of $-\alpha$ at an input of $-\beta$). The integrand of (7-21) must be zero over intervals for which $|x_1 + x_{*}| > \beta + \epsilon$ when $x_{*} = x_{*}'$ and also $x_{*} = x_{*}''$. Likewise it is zero on intervals for which $|x_1 + x_{*}| < \beta$. For intervals on which $|x_1 + x_{*}''| > \beta + \epsilon$ and $|x_1 + x_{*}'| < \beta$, the integrand is equal to α . Finally, on the interval $|x_1 + x_{*}| = \beta$ to $|x_1 + x_{*}| = \beta + \epsilon$ the integrand is either $\alpha(x_1 + x_{*})/\epsilon$ or $\alpha(1 - x_1 - x_{*})/\epsilon$.

Let $|x_{*}|_{\beta}$ be the value of x_{*} when $|x_1 + x_{*}| = \beta$. By using the limits enumerated above, (7-21) can be estimated by

$$\begin{aligned}
f \leq \frac{2\alpha}{\pi} & \left[\int_{\sin^{-1} \frac{\beta + |x_*'|_{\beta}}{a}}^{\sin^{-1} \frac{\beta + |x_*'|_{\beta} + \epsilon}{a}} d\theta - \frac{1}{\epsilon} \int_{\sin^{-1} \frac{\beta + |x_*'|_{\beta}}{a}}^{\sin^{-1} \frac{\beta + |x_*'|_{\beta} + \epsilon}{a}} (x_1 + x_*') d\theta \right. \\
& \left. + \frac{1}{\epsilon} \int_{\sin^{-1} \frac{\beta + |x_*''|_{\beta}}{a}}^{\sin^{-1} \frac{\beta + |x_*''|_{\beta} + \epsilon}{a}} (x_1 + x_*'') d\theta \right]. \quad (7-22)
\end{aligned}$$

While the integrand in the last two integrals in (7-22) cannot be evaluated without knowing the exact form of x_* , it does possess certain characteristics which may be used to bound the integrals:

- 1) It is zero at the lower limit of integration.
- 2) It is continuous, as all solutions $x(t)$ are continuous.
- 3) The maximum value of $(x_1 - x_*'')$ as an integrand in (7-22) must be $|x_*' - x_*''|_s$ as this is the maximum input the nonlinearity sees.

Accordingly, each of the last two integrals in (7-22) can be represented, after a transformation of variables, by

$$\frac{1}{\epsilon} \int_{\sin^{-1} \frac{\beta + |x_*|_{\beta}}{a}}^{\sin^{-1} \frac{\beta + |x_*|_{\beta} + \epsilon}{a}} (x_1 + x_*) d\theta = \frac{|x_*'' - x_*'|}{\epsilon} \int_0^{\epsilon} \Delta(\zeta) d\zeta$$

where $\Delta(\zeta)$ is a suitable continuous function which, from characteristic 3, has the property $|\Delta|_S \leq 1$. One may then estimate the integral as

$$\frac{|x_*'' - x_*'|}{\varepsilon} \int_0^\varepsilon \Delta(\zeta) d\zeta \leq \sup_{0 < \zeta < \varepsilon} |\Delta(\zeta)| |x_*'' - x_*'|_S.$$

Returning to (7-22), one obtains

$$F \leq \frac{2\alpha}{\pi} \left[\left| \sin^{-1} \frac{\beta + |x_*'|_\beta + \varepsilon}{a} - \sin^{-1} \frac{\beta + |x_*''|_\beta + \varepsilon}{a} \right| + \sup_{0 < \zeta < \varepsilon} |\Delta(\zeta)| |x_*'' + x_*'|_S \right].$$

Applying the mean value theorem one obtains

$$F \leq \frac{2\alpha}{\pi} \left[\frac{1}{\sqrt{1 - \left(\frac{\beta + |x_*'|_S + \varepsilon}{a} \right)^2}} (|x_*'|_\beta - |x_*''|_\beta) + \sup_{0 < \zeta < \varepsilon} |\Delta(\zeta)| |x_*'' - x_*'|_S \right]$$

which, when substituted into (7-18) becomes

$$\begin{aligned} & |[P_*^1 g_n(x_1 + x_*'')] - [P_*^1 g_n(x_1 + x_*')]|_1 \\ & \leq \left(\frac{2\alpha}{\pi a} \sum_{|k| > 3} |G(jk\omega)| \right) \left(\frac{1}{\sqrt{1 - \left(\frac{\beta + |x_*'|_1 + \varepsilon}{a} \right)^2}} + \sup_{0 < \zeta < \varepsilon} |\Delta(\zeta)| \right) \cdot |x_*'' - x_*'|_1. \end{aligned} \quad (7-23)$$

However, as $\epsilon \rightarrow 0$, so does $\sup_{0 < \zeta < \epsilon} |\Delta(\zeta)|$ from characteristic 1. Then if (7-8) is satisfied, the higher harmonics are contractive for ϵ sufficiently small from (7-23), and x_* is unique.

Now turn to the DF equation. As P and g are linear, one may write from (7-10)

$$|x_1 + P g n_{\epsilon} x_1| \leq |P g \sigma(a, x_h)| a$$

where

$$\begin{aligned} \sigma(a, x_h) &= |P [n_{\epsilon} x_1 - n_{\epsilon}(x_1 + x_*)] / a & (7-24) \\ &= 1/a \left| \int_0^{2\pi} [n_{\epsilon}(a \sin \theta) - n_{\epsilon}(a \sin \theta + x_*)] \sin \theta \, d\theta \right|. \end{aligned}$$

The integral is evaluated using the same techniques as (7-21); one computes the function in brackets due to error in switching point and takes the first Fourier coefficient.

a) Ideal Relay - one has two switching regions

$$\begin{aligned} \sigma(a, |x_*|_1) &\leq \frac{2A}{\pi a} \left[\int_0^{\sin^{-1} \frac{|x_*|_1 + \epsilon}{a}} \sin \theta \, d\theta \right. \\ &\quad \left. + \int_{\pi}^{\sin^{-1} \pi + \frac{|x_*|_1 + \epsilon}{a}} \sin \theta \, d\theta \right] \\ &= \frac{4A}{\pi a} \left[1 - \sqrt{1 - \left(\frac{|x_*|_1 + \epsilon}{a} \right)^2} \right]. \end{aligned} \quad (7-26)$$

- b) Relay with Deadzone - one now has four switching regions with two possible conditions on $|x_*|_1$

$$\begin{aligned} \sigma(a, |x_*|_1) &= \frac{4A}{\pi a} \int_{\sin^{-1} \frac{B - |x_*|_1 - \epsilon}{a}}^{\sin^{-1} \frac{B + |x_*|_1 + \epsilon}{a}} \sin \theta \, d\theta \\ &= \frac{4A}{a} \left[\sqrt{1 - \left(\frac{B - |x_*|_1 - \epsilon}{a} \right)^2} - \sqrt{1 - \left(\frac{B + |x_*|_1 + \epsilon}{a} \right)^2} \right] \\ |x_*|_1 &< B + \epsilon \end{aligned} \quad (7-27)$$

$$\begin{aligned} \sigma(a, |x_*|_1) &= \frac{4A}{\pi a} \int_0^{\sin^{-1} \frac{|x_*|_1 + B + \epsilon}{a}} \sin \theta \, d\theta \\ &= \frac{4A}{\pi a} \left[1 - \sqrt{1 - \frac{B + |x_*|_1 + \epsilon}{a}^2} \right] \\ |x_*|_1 &> B + \epsilon \end{aligned} \quad (7-28)$$

- c) Staircase Function - This is just a sum of functions of class b.

Then all conditions of Theorem I have been verified and the results follow. ■

A word of comment on the solution of (7-3) is in order. The theorem may be used to prove a periodic solution exists when a DF solution predicts oscillation; however, in the case of a staircase function, the DF method may predict multiple modes of oscillation. To meet the uniqueness requirement on x_* , it is necessary for this type of analysis that solutions be sufficiently separated so that Ω contains only one DF solution. The relay system has only one output while the staircase function may 'change steps'. In the latter case, the uniqueness of solution may not be preserved, and the method would have to be modified accordingly.

Some examples of the application of Theorem VIII on systems with ideal relay, relay with deadzone, and staircase function are given in Figures 7-5, 7-6, and 7-7 respectively.

The preceding theorem is implemented graphically, similar to Theorem III. The following corollary can be applied algebraically in the case of an ideal relay.

Corollary VIII: Let S satisfy (3-1) and contain an ideal relay with $n(x) \in J_\epsilon$ and there is a DF solution $(\hat{a}, \hat{\omega})$.

Let there exist an interval W along the ω axis

$$W = \{\omega: \omega_1 < \omega < \omega_2, \omega_1 < \hat{\omega} < \omega_2\} \quad (7-29)$$

such that everywhere along W the set

$$N'(\omega) = \left\{ N(a): N(a) > N(\hat{a}), \left| \frac{1}{G(j\omega)} + N(a) \right| > \left| \frac{\pi^2 N^3(a)}{16} \sum_{|k| > 1} \frac{[G(jk\omega)]^2}{[G(jk\omega)]} \right\} \quad (7-30)$$

1.9A	A	2.02	OMEGA	RF 1/G(JW)	IM 1/G(JW)	IG(JW)1
			.99A000	-.994010	.001990	.994012
			.99A06R	-.994213	.001923	.994214
			.99A136	-.994415	.001856	.994417
			.99A203	-.994618	.0017A9	.994620
			.99A271	-.994821	.001721	.994822
			.99A339	-.995024	.001650	.995025
			.99A407	-.995226	.001587	.995228
			.99A474	-.995429	.001520	.995430
			.99A542	-.995632	.001452	.995633
			.99A610	-.995835	.001385	.995836
			.99A678	-.996038	.001318	.996039
			.99A746	-.996241	.001250	.996242
			.99A813	-.996444	.001183	.996445
			.99A881	-.996647	.001116	.996648
			.99A949	-.996850	.001048	.996850
			.99A017	-.997053	.000981	.997054
			.99A085	-.997256	.000913	.997256
			.99A152	-.997459	.000846	.997459
			.99A220	-.997662	.000778	.997663
			.99A288	-.997865	.000711	.997866
			.99A356	-.998069	.000643	.998069
			.99A424	-.998272	.000576	.998272
			.99A491	-.998475	.000508	.998475
			.99A559	-.998678	.000440	.998678
			.99A627	-.998881	.000373	.998881
			.99A695	-.999085	.000305	.999085
			.99A763	-.999288	.000237	.999288
			.99A830	-.999491	.000170	.999491
			.99A898	-.999695	.000102	.999695
			.99A966	-.999898	.000034	.999898
			1.000033	-1.000100	-.000033	1.000100
			1.000101	-1.000303	-.000101	1.000303
			1.000169	-1.000506	-.000169	1.000506
			1.000237	-1.000710	-.000237	1.000710
			1.000304	-1.000913	-.000304	1.000913
			1.000372	-1.001116	-.000372	1.001116
			1.000440	-1.001319	-.000440	1.001320
			1.000508	-1.001522	-.000509	1.001526
			1.000576	-1.001729	-.000577	1.001729
			1.000644	-1.001932	-.000645	1.001932
			1.000711	-1.002136	-.000713	1.002136
			1.000779	-1.002339	-.000781	1.002339
			1.000847	-1.002542	-.000849	1.002543
			1.000915	-1.002746	-.000917	1.002746
			1.000982	-1.002949	-.000985	1.002950
			1.001050	-1.003153	-.001053	1.003153
			1.001118	-1.003356	-.001121	1.003357
			1.001185	-1.003560	-.001189	1.003560
			1.001254	-1.003766	-.001258	1.003767
			1.001322	-1.003970	-.001326	1.003971
			1.001390	-1.004173	-.001394	1.004174
			1.001457	-1.004377	-.001463	1.004378
			1.001525	-1.004581	-.001531	1.004582
			1.001593	-1.004784	-.001599	1.004786
			1.001660	-1.004988	-.001667	1.004989
			1.001728	-1.005192	-.001736	1.005193
			1.001796	-1.005395	-.001804	1.005397
			1.001864	-1.005599	-.001872	1.005601
			1.001931	-1.005803	-.001941	1.005805

FIGURE 7-5 PROOF OF OSCILLATION BY THEOREM VIII

IDEAL RELAY, A = 1.57

$$G(s) = \frac{s - 1}{s^4 + s^3}$$

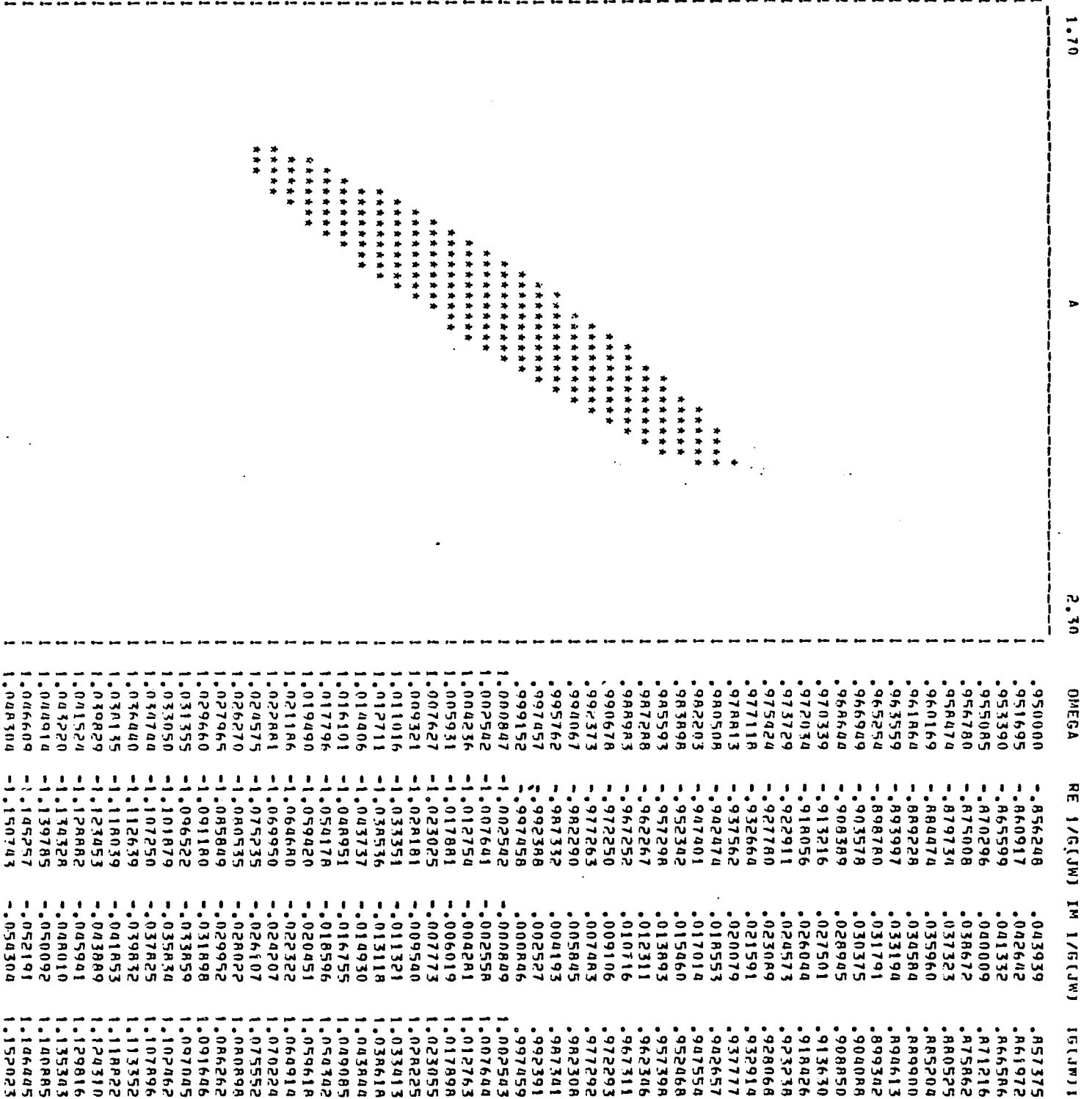

FIGURE 7-6 PROOF OF OSCILLATION BY THEOREM VIII

RELAY WITH DEADZONE, A = 1.62, B = .5

$$G(s) = \frac{s - 1}{s^4 + s^3}$$

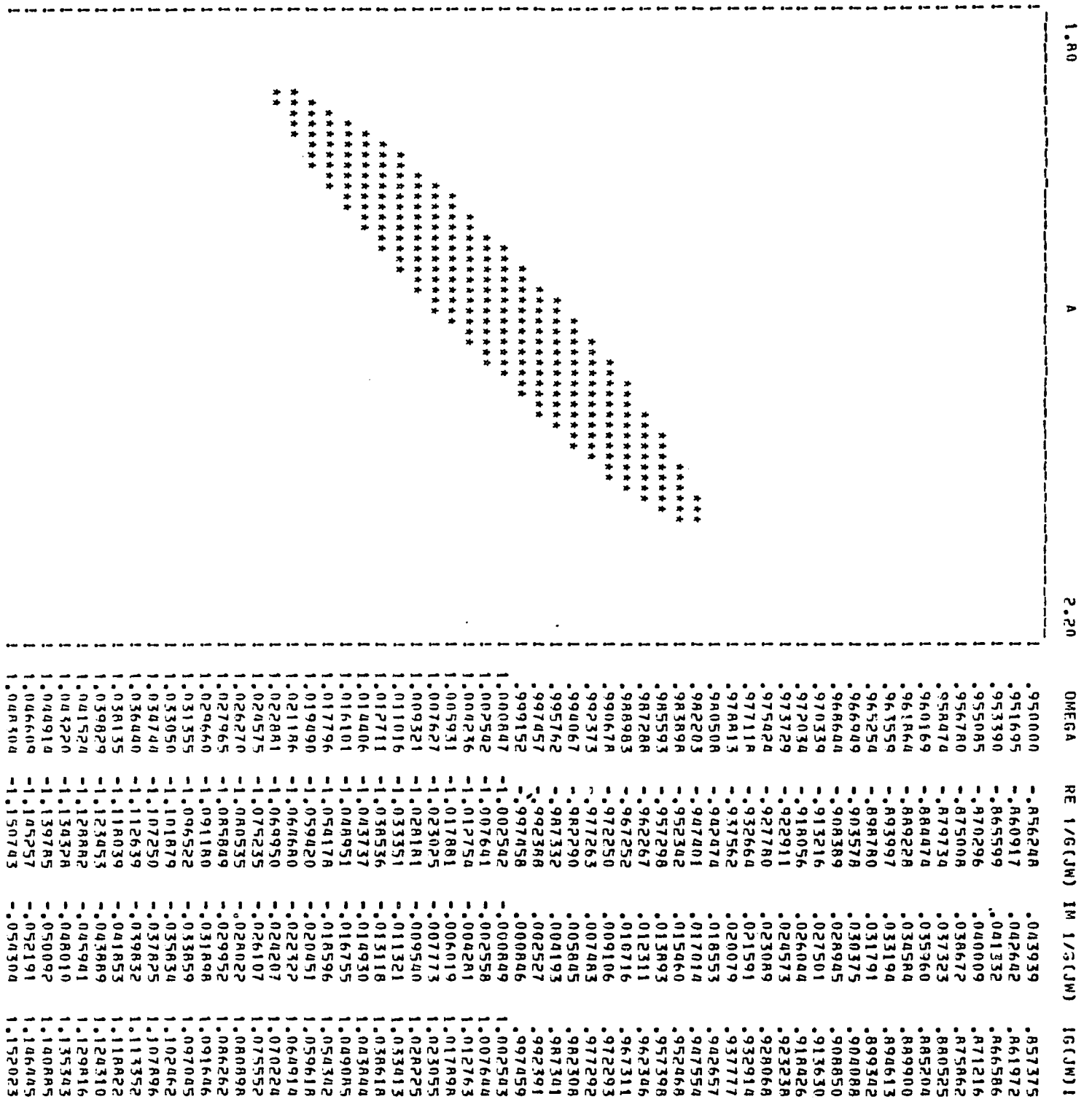

FIGURE 7-7 PROOF OF OSCILLATION BY THEOREM VIII

STAIRCASE FUNCTION, $A_1 = .75, B_1 = 0.0$
 $A_2 = 1.25, B_2 = .5$
 $A_3 = 1.6378, B_3 = 1.0$

$$G(s) = \frac{1}{s^4 + s^3}$$

is not empty. Suppose the following quantities exist

$$\bar{N}(\omega) = \inf_{N \in N'(\omega)} |N(a)|$$

$$\tilde{N} = \sup_{\omega \in W} \bar{N}(\omega).$$

Then if

$$|\operatorname{Im}(1/G(j\omega))| > \begin{cases} \frac{\pi^2 \bar{N}^3(\omega)}{16} & \omega = \omega_1 \\ \frac{\pi^2 \tilde{N}^3}{16} & \omega = \omega_2 \end{cases} \sum_{|k| > 1} [G(jk\omega)]^2, \quad (7-31)$$

and

$$\left| \frac{\tilde{N} \sum_{|k| > 1} |G(jk\omega)|}{\frac{1}{2} \sqrt{1 - \frac{\pi^2 \tilde{N}^2}{16} \sum_{|k| > 1} [G(jk\omega)]^2}} \right| < 1, \quad \forall \omega \in W \quad (7-32)$$

and $-1/G(j\omega)$ is not parallel to $N(a)$ at $\omega = \hat{\omega}$, an oscillation exists with (a, ω) in the region $\omega_1 < \omega < \omega_2$, $0 < N(a) < \tilde{N}$.

Proof: It can be shown that the DF of a limiter approaches that of a relay as $\varepsilon \rightarrow 0$ in Figure 7-2. Then

$$N_\varepsilon(a) = \frac{4A}{\pi a} c(\varepsilon), \quad \text{where } c(\varepsilon) \rightarrow 1 \text{ as } \varepsilon \rightarrow 0 \quad (7-33)$$

and, substituting in the second condition in (7-30), one obtains

$$|1/G(j\omega) - N(a)| > |c|^3 \left| \frac{4A}{\pi a} \right| \left(\frac{1}{a^2} \right) A^2 \sum_{|k| > 1} [G(jk\omega)]^2. \quad (7-34)$$

From Theorem VIII, $x_h = A \left(\sum_{|k| > 1} [G(jk\omega)]^2 \right)^{1/2} + \epsilon$. Then (7-34)

can be written

$$|1/G(j\omega) - N(a)| > |c|^3 \frac{4A}{\pi a} \left(\frac{x_h - \epsilon}{a} \right)^2. \quad (7-35)$$

Now

$$1 - \sqrt{1 - \left(\frac{x_h - \epsilon}{a} \right)^2} = \frac{\left(\frac{x_h - \epsilon}{a} \right)^2}{1 + \sqrt{1 - \left(\frac{x_h - \epsilon}{a} \right)^2}} \leq \left(\frac{x_h - \epsilon}{a} \right)^2.$$

Hence by (7-30)

$$\begin{aligned} |1/G(j\omega) - N(a)| &> \frac{4A}{\pi a} \left(1 - \sqrt{1 - \left(\frac{x_h}{a} \right)^2} \right) \\ &> \frac{4|c|^3 A}{\pi a} \left(1 - \sqrt{1 - \left(\frac{x_h - \epsilon}{a} \right)^2} \right) \end{aligned} \quad (7-36)$$

for ϵ sufficiently small. Consider a square region bounded on three sides by ω_1 , ω_2 , \tilde{N} which contains (\hat{N}, ω) ; these boundaries have been shown to exist from (7-30) and (7-31). Now let $N(a) \rightarrow 0$ in (7-36). One obtains $|1/G(j\omega)| > 0$ which is surely true; hence the fourth side of the square boundary must exist.

Equation (7-32) guarantees uniqueness of x_* within the square, and by Theorem VIII, an oscillation exists. ■

An example of the use of this corollary is given in Figure 7-8. For some nonlinearities, one may derive sharper estimates by representing it as the sum of two nonlinear functions, one a staircase function and the second a polynomial. An example of a function that would be a

LINEAR TRANSFER FUNCTION, LOW ORDER TERMS FIRST

NUMERATOR	0.0000	0.0000	1.0000		
DENOMINATOR	1.0000	-0.2500	1.0000	-0.2500	1.0000

W	N(W)	SUP(G)	L2(G)
0.9600	1.0300	0.5143	0.0420
0.9700	1.0300	0.5031	0.0401
0.9800	1.0300	0.4922	0.0384
0.9900	1.0300	0.4818	0.0367
1.0000	1.0300	0.4716	0.0352
1.0100	1.0300	0.4618	0.0337
1.0200	1.0300	0.4523	0.0323
1.0300	1.0200	0.4431	0.0309

THE CONTRACTION CONSTANT IS 0.45156028

FIGURE 7-8 PROOF OF OSCILLATION BY COROLLARY VIII

$$G(s) = s^2 / (s^4 - .25s^3 + s^2 - .25s + 1)$$

candidate for such a procedure is shown in Figure 7-9. Let the two functions comprising n be termed n_ϵ and n_2 , with n_ϵ a staircase function.

Consider the case where n_2 may be represented by

$$n_2(x) = \sum_{k=3}^Q b_p x^p. \quad (7-37)$$

If n_2 is odd, non-decreasing, and with non-decreasing slope, then one writes $n_2 \in M$.

The next theorem gives conditions under which the existence of oscillations can be verified for n which is the sum of a function in J_ϵ and one in M .

Theorem IX: Let S satisfy (3-1) and contain a nonlinearity that can be represented by the sum of a staircase function n_ϵ and $n_2 \in M$, and let ϵ be sufficiently small.

1) Suppose there is a DF solution $(\hat{a}, \hat{\omega}) \in \Omega$ where Ω is a disc in (a, ω) , and on $\partial\Omega$

$$|1/G(j\omega) + N(a)| > \sigma \quad (7-38)$$

where

$$\sigma = \frac{4}{\pi a} \sum_{i=1}^k (A_i - A_{i-1}) [\Gamma(a, B_i, x_h) - \Gamma(a, B_i, -x_h)] + \frac{\lambda x_h}{2a}, \quad A_0 = 0 \quad (7-39)$$

$$|2/G(jk\omega) + \lambda| = \inf_{L > 1} \left| \frac{2}{G(jL\omega)} + \lambda \right| \quad (7-40)$$

and there is a solution to the system of equations

$$y_h = \frac{\lambda a + 2N_\epsilon (a + y_h) \sqrt{\sum_{|L| > 1} [G/jL\omega]^2 / |G(jk\omega)|}}{\left| \frac{2}{G(jk\omega)} + \lambda \right| - \lambda} ;$$

$$x_h = y_h + \epsilon \quad (7-41)$$

$$\lambda = \sum_{p=3}^Q pb_p (a + x_h)^{p-1}, \quad (7-42)$$

$$\text{with } \left| \frac{2}{G(jk\omega)} + \lambda \right| - \lambda > 0.$$

Further, let

$$\left| \left(\lambda + \frac{2A_i}{\pi a \sqrt{1 - \left(\frac{B_i + x_h}{a} \right)^2}} \right) \sum_{|k| > 3} |G(jk\omega)| \right| < 1 \quad \forall (a, \omega) \in \Omega \quad (7-43)$$

where $i = \min \{j | a - B_j > 0\}$. Then an oscillation exists with $(a, \omega) \in \Omega$.

- 2) If, for all points within a disc Ω in (a, ω) (7-38) is satisfied and (7-43) is satisfied, then no oscillation with $(a, \omega) \in \Omega$ exists.

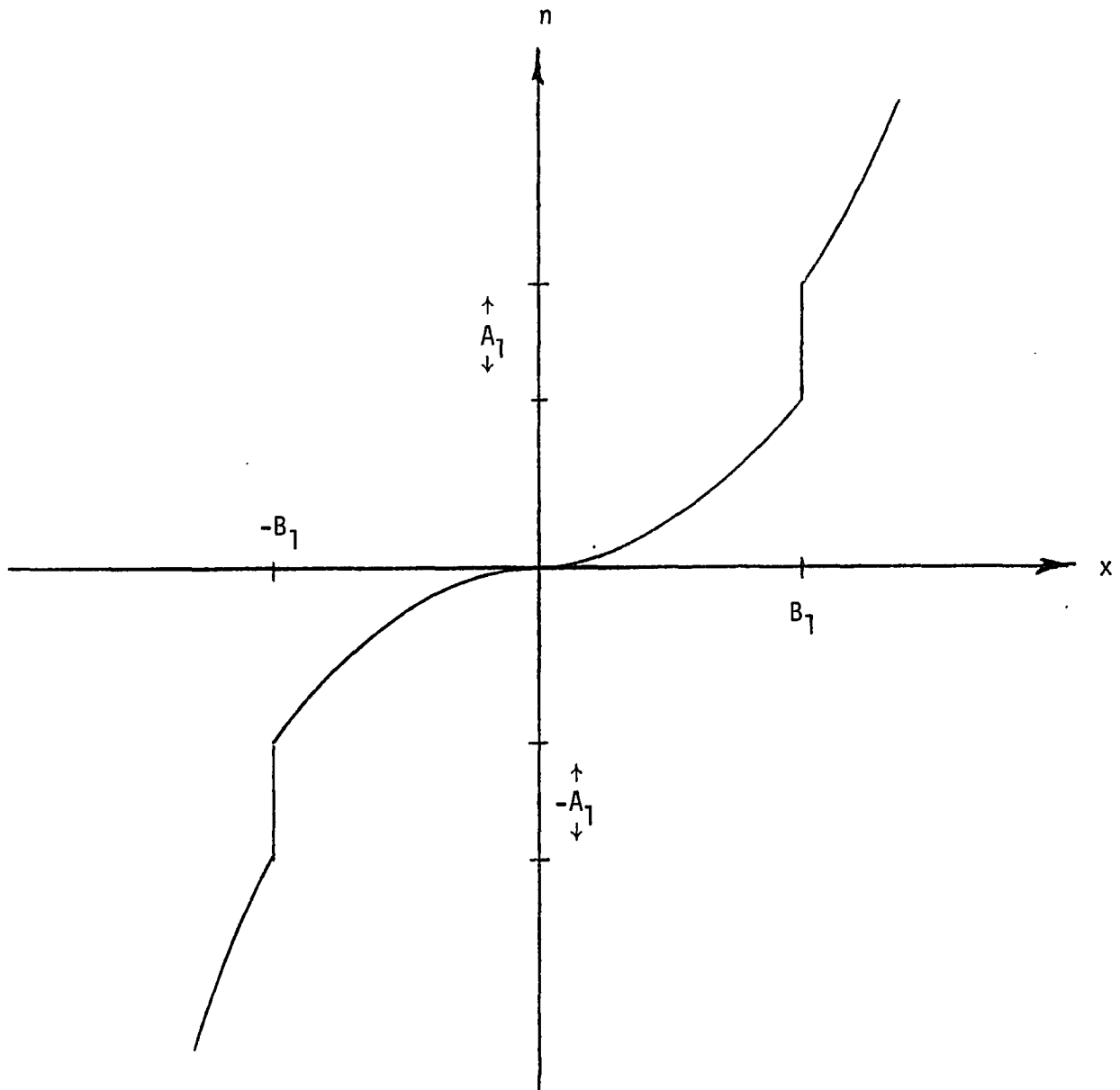

FIGURE 7-9 NONLINEARITY UNDER CONSIDERATION

Proof: A series of block diagram manipulations allows the system to be represented as shown in Figure 7-6. The composition gn_ϵ is represented by the symbol r . Figure 7-10 satisfies the functional equation

$$x = -gn_2x - r(x). \quad (7-44)$$

Let x be a periodic solution of (7-44). It was shown in Theorem VIII, (7-3) that $|r(x)|_1 < \infty$, and (4-11) shows that $|gn_2x| < \infty$. One may associate a quantity λ with n_2 such that $\lambda \geq |dn_2/dx|_S$. Taking the usual projection operators on (7-44) yields

$$x_* = -P_*^1 gn_2(x_1 + x_*) - P_*^1 r(x_1 + x_*) \quad (7-45)$$

$$x_1 + P_*^1 gn_2 x_1 = P_*^1 g(n_2 x_1 - n_2(x_1 + x_*)) + P_*^1 (gn_\epsilon x_1 - r(x_1 + x_*)). \quad (7-46)$$

First one shows the uniqueness of x_* as a function of (a, ω) by investigating the contractive properties of (7-45). Consider the two points x_*' , x_*'' with the metric $|x_*'' - x_*'|_1$. Let

$$y = n_2(x) = \sum_{k=-\infty}^{\infty} B_k e^{jk\omega t}, \quad B_k \in \mathbb{C}.$$

Start by evaluating the expression

$$\begin{aligned} |P_*^1 gn_2(x_1 + x_*'') - P_*^1 gn_2(x_1 + x_*')| &= \sum_{|k| > 1} |G(jk\omega) (B_k'' - B_k')| \\ &\leq \left(\sum_{|k| > 1} |G(jk\omega)| \right) \max_{|k| > 1} |B_k'' - B_k'|. \end{aligned} \quad (7-47)$$

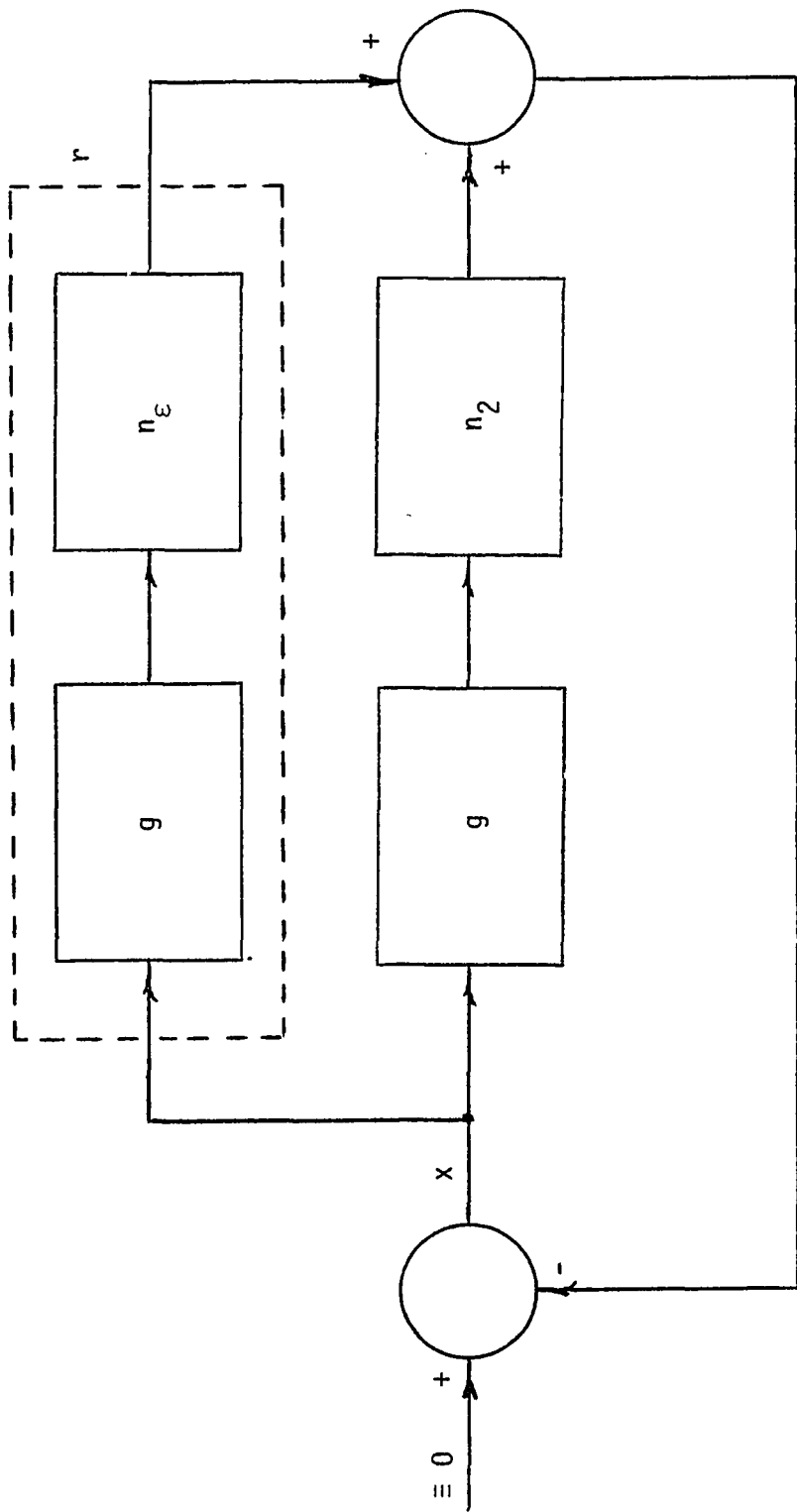

FIGURE 7-10 EQUIVALENT CONTROL SYSTEM

Examining the last term in (7-47), one sees that

$$\begin{aligned}
 \max_{|k| > 1} |B_k'' - B_k'| &= \max_{|k| > 1} \frac{1}{2\pi} \int_0^{2\pi} [n_2(x'') - n_2(x')] e^{jk\theta} d\theta \\
 &\leq \left| \frac{1}{2\pi} \int_0^{2\pi} |n_2(x'') - n_2(x')| d\theta \right| \leq \left| \frac{\lambda}{2\pi} \int_0^{2\pi} |x'' - x'| d\theta \right| \\
 &\leq \lambda |x'' - x'|_S \leq \lambda |x_*'' - x_*'|_1
 \end{aligned} \tag{7-48}$$

so that (7-47) becomes

$$\begin{aligned}
 &|P_*^1 g n_2(x_1 + x_*'') - P_*^1 g n_2(x_1 + x_*')|_1 \\
 &\leq \left(\lambda \sum_{|k| > 1} |G(jk\omega)| \right) |x_*'' - x_*'|_1.
 \end{aligned} \tag{7-49}$$

The quantity $|P_*^1 r(x_1 + x_*'') - P_*^1 r(x_1 + x_*')|$ was evaluated in Theorem VIII, equation (7-23). From the triangle inequality, and (7-47), (7-23), one obtains

$$\begin{aligned}
 &|P_*^1 g n_2(x_1 + x_*'') + P_*^1 r(x_1 + x_*'') - P_*^1 n_2(x_1 + x_*') - P_*^1 r(x_1 + x_*')|_1 \\
 &\leq \left| \left(\lambda(|x|_1) + \frac{2A_j}{\pi a \sqrt{1 - \left(\frac{B_j + x_*}{a}\right)^2}} \right) \sum_{|k| > 1} |G(jk\omega)| \right| \\
 &|x_*'' - x_*'|_1.
 \end{aligned} \tag{7-50}$$

Hence when (7-43) is satisfied, the map (7-45) is contractive.

An estimate of the bound on x_* will now be obtained. Let

$$R_* = P_*^1 r(x). \quad (7-51)$$

From (7-45) one now obtains

$$x_* = -P_*^1 g n_2(x_1 + x_*) + R_* . \quad (7-52)$$

Sharper results are gotten by pole shifting this equation to obtain

$$x_* \left(1 + \frac{P_*^1 g \lambda(|x|_1)}{2} \right) = P_*^1 g \left(\frac{\lambda(|x|_1)}{2} x_* - n_2(x_1 + x_*) \right) + R_* \quad (7-53)$$

which can be put in the form

$$x_* = \frac{P_*^1 g \left(\frac{\lambda(|x|_1)}{2} x_* - n_2(x_1 + x_*) \right) + R_*}{1 + \frac{P_*^1 g \lambda(|x|_1)}{2}} \quad (7-54)$$

provided that

$$\inf_{k > 1} |1 + G(jk\omega) \lambda(|x|_1)/2| \neq 0; \quad (7-55)$$

which is implied by (7-40). Theorem III, equations (4-16) and (4-18), show how the $| \cdot |_1$ may be estimated for the n_2 function. When (7-50) holds, there is a unique solution to (7-54) satisfying

$$|x_*|_1 \leq \sup_{|k| > 1} \left| \frac{\lambda(|x|_1)}{\frac{2}{P_*^1 g} + \lambda(|x|_1)} \right| (|x_*|_1 + |x_1|_1) + \sup_{|k| > 1} \left| \frac{R_*}{1 + \frac{P_*^1 g \lambda(|x|_1)}{2}} \right| \quad (7-56)$$

when

$$\frac{\lambda(|x|_1)}{\inf_{k > 1} \left| \frac{2}{G(jk\omega)} + \lambda(|x|_1) \right|} < 1 \quad (7-57)$$

one may solve (7-56) for $|x_*|_1$ yielding

$$|x_*|_1 \leq \frac{\lambda(|x|_1) |x|_1 + (2/G(jk\omega)) |R_*|_1}{|2/G(jk\omega) + \lambda| - \lambda} \quad (7-58)$$

where k is given by (7-40). Note that (7-57) implies (7-55). Finally, $|R_*|_1$ is a function of $|x|$; however, it takes on only discrete values corresponding to the steps of the staircase. From (7-3), one obtains

$$|R_*|_1 \leq A_i \sum_{|k| > 3} \sum |G(jk\omega)|; |x|_s < B_i \quad (7-59)$$

which, when combined with (7-58), yields (7-41).

Evaluation of the DF error (the right side of (7-39)) is straight forward, and follows from the sum of the error terms given in Theorem III (4-28) and Theorem VIII (7-6). The computation of λ from n_2 given in (7-37) follows exactly as in Theorem III.

The conditions of Theorem I have been verified and the results follow. ■

The remarks concerning solutions of (7-3) also apply to solutions of (7-41). Likewise, the remarks concerning solvability of $2\sigma/\lambda$ for Theorem III. In fact, when $n_2 = 0$ one obtains Theorem VIII as a corollary, and when $n_1 = 0$ one obtains a form of Theorem III. An example of the application of Theorem IX is given in Figure 7-11.

OMEGA	RF 1/G(JW)	IM 1/G(JW)	IG(JW)1
.995000	-.934937	.054813	.936502
.995169	-.937714	.052961	.938639
.995339	-.939351	.051109	.940740
.995508	-.941558	.049256	.942846
.995678	-.943765	.047403	.944955
.995847	-.945972	.045550	.947068
.996017	-.948179	.043696	.949185
.996186	-.950385	.041842	.951306
.996356	-.952591	.039987	.953430
.996525	-.954798	.038132	.955559
.996695	-.957004	.036276	.957691
.996864	-.959210	.034420	.959827
.997034	-.961416	.032564	.961967
.997203	-.963621	.030707	.964110
.997373	-.965827	.028849	.966258
.997542	-.968032	.026992	.968408
.997712	-.970237	.025138	.970562
.997881	-.972442	.023275	.972721
.998051	-.974647	.021416	.974882
.998220	-.976852	.019556	.977048
.998389	-.979057	.017696	.979217
.998559	-.981261	.015836	.981389
.998728	-.983466	.013975	.983565
.998898	-.985670	.012114	.985744
.999067	-.987874	.010252	.987927
.999237	-.990078	.008390	.990114
.999406	-.992282	.006528	.992303
.999576	-.994486	.004664	.994497
.999745	-.996689	.002801	.996693
.999915	-.998892	.000938	.998892
1.000084	-.1.001091	-.000923	1.001091
1.000254	-.1.003298	-.002791	1.003302
1.000422	-.1.005492	-.004649	1.005503
1.000592	-.1.007698	-.006517	1.007719
1.000762	-.1.009904	-.008386	1.009939
1.000931	-.1.012098	-.010245	1.012150
1.001101	-.1.014300	-.012115	1.014376
1.001270	-.1.016510	-.013985	1.016606
1.001440	-.1.018715	-.015856	1.018839
1.001609	-.1.020909	-.017717	1.021062
1.001779	-.1.023114	-.019588	1.023301
1.001948	-.1.025319	-.021460	1.025504
1.002117	-.1.027512	-.023342	1.027776
1.002287	-.1.029717	-.025195	1.030025
1.002457	-.1.031922	-.027069	1.032277
1.002626	-.1.034126	-.028942	1.034534
1.002795	-.1.036318	-.030806	1.036776
1.002965	-.1.038523	-.032681	1.039037
1.003135	-.1.040727	-.034556	1.041300
1.003304	-.1.042919	-.036421	1.043554
1.003473	-.1.045123	-.038296	1.045824
1.003643	-.1.047326	-.040173	1.048096
1.003813	-.1.049530	-.042050	1.050372
1.003982	-.1.051721	-.043916	1.052638
1.004151	-.1.053924	-.045794	1.054919
1.004321	-.1.056128	-.047672	1.057203
1.004490	-.1.058318	-.049540	1.059477
1.004660	-.1.060521	-.051419	1.061767
1.004820	-.1.062727	-.053298	1.064060

FIGURE 7-11 PROOF OF OSCILLATION BY THEOREM IX

$$n(x) = 4(t - 1) - u(1 - t) + .149x^3$$

$$G(s) = \frac{s - 1}{s^4 + s^3 - 10s^2 - 10}$$

CHAPTER VIII

CONCLUSIONS AND RECOMMENDATIONS

It has been demonstrated that sufficient conditions for oscillation, as well as for absence of oscillations, in a class of nonlinear systems with differentiable elements can be obtained when the higher harmonics are sufficiently attenuated. This applies even in the case in which the nonlinearity is not bounded. The question of precisely what constitutes sufficient attenuation of the higher harmonics is answered by examining a plot in parameter plane of the error inherent in using the DF approximation. In case that the DF predicts oscillation, and the parameter plot contains a region homeomorphic to a disc, an oscillation is indicated. Further, no oscillation can exist for parameters outside this region.

When the degree of attenuation of the linear portion is not sufficient to give conclusive results with a DF approach, a MIDF approach is used. By constructing a DIDF model of a cubic nonlinearity, significant improvements were demonstrated in estimating the region of oscillation of some example systems. In one case, it was possible to draw conclusions from the DIDF approach, while nothing could be said from the DF alone.

Theorem III is different from theorems in some previous DF justification work [10, 68, 93] in that the error bounds are plotted as functions of both a and ω . This precludes plotting of error bounds in the complex plane containing $N(a)$ and $-1/G(j\omega)$. One plots the region

in the (a, ω) plane containing the oscillatory parameter values. The notion of error bands is not as natural here, although it is well suited for topological examination of the system solutions.

In Theorem IV the attenuation in the linear portion (sufficient for oscillation) can be represented as a function of the nonlinearity. This leads to a simple method for checking the design of oscillatory systems, although it is conservative. It has also been shown that the term with the highest exponent in the polynomial dominates in such a manner as to allow the application of the simple procedure given in Theorem VII as a design aid.

Applicability of topological techniques to systems with bounded nonlinearities was demonstrated in Theorem VIII. It is seen in Theorem IX that in some cases the error estimates can be sharpened by representing the nonlinearity as the sum of two functions: one which is bounded and has zero slope except in intervals of arbitrarily small width and the other a polynomial.

The methods might be useful tools in analyzing systems which, while lacking a DF solution, have a DIDF solution indicating oscillation. It is probably true that such systems would require an even higher order describing function to apply Theorem V. Application to, say, the Fitts example [47] seems possible, although one would likely need a four or five input DF to do the analysis. Programming this on a digital computer should be possible with a reasonable computation time considering available computers and programming techniques.

Only nonlinearities with odd symmetry were considered in this work; this form allows one to look for π -symmetric oscillations. Such

oscillations have only odd harmonics. It is possible to obtain equivalent results for nonlinearities that are not odd; in this case the Fourier series representing the solution must contain all the harmonics, not just the odd ones. This implies an oscillation whose average value is not zero, and the term a_0 must be taken into account. The new theorems would look very much in form like the ones stated, but the computations required to apply them would be increased.

In the course of pursuing a study of this nature, the need for more research in various areas becomes apparent. A method of solving simultaneous nonlinear equations is necessary for allowing Theorem V to be applied to a describing function approach with a large number of harmonics accounted for. The number of calculations required here is large, and for the method to be useful, the algorithm must be efficient.

It would also be informative to extend the results presented to treat the case of systems containing multiple nonlinearities. A method of using describing functions in this case is given in [91], however, no attempt has been made to rigorously show the existence or nonexistence of oscillations.

REFERENCES

1. Acker, A., "Stability Criteria for Time-Varying Systems in Hilbert Space," Siam Journal of Optimization and Control, vol. 13, no. 6, 1975, pp. 1156-1171.
2. Aizerman, M. A. and Gantmakher, F. R., "On Critical Cases in the Theory of Absolute Stability of Controlled Systems," Automation and Remote Control, vol. 24, no. 6, June, 1963, pp. 669-673.
3. Atherton, D. P. and Ramani, N., "A Method for the Evaluation of Limit Cycles," International Journal of Control, vol. 21, no. 3, March, 1975, pp. 375-384.
4. Atherton, D. P. and Dorrah, H. T., "A Survey on Non-Linear Oscillations," International Journal of Control, vol. 31, no. 6, June, 1980, pp. 1041-1105.
5. Baker, R. A. and Desoer, C.A., "Asymptotic Stability in the Large of a Class of Single-Loop Feedback Systems," Siam Journal of Optimization and Control, vol. 6, no. 1, 1968, pp. 1-8.
6. Barkham, P. G. D. and Soudack, A. C., "Limit-Cycle Phenomena in Non-Linear Time-Delay Systems," International Journal of Control, vol. 27, no. 3, March, 1978, pp. 407-420.
7. Belova, D. A. and Netushil, A. V., "Absolute Stability of Control Systems having Ambiguous Backlash and Stop Nonlinearities," Automation and Remote Control, vol. 28, no. 12, December, 1967, pp. 1865-1869.
8. Benes, V. E. and Sandberg, I. W., "Application of a Theorem of Dubrovskii to the Periodic Responses of Nonlinear Systems," Bell Systems Technical Journal, vol. 43, no. 6, November, 1964, pp. 2855-2872.
9. Bergen, A. R. and Sapiro, M. A., "The Parabola Test for Absolute Stability," IEEE Transactions on Automatic Control, vol. AC12, 1967, pp. 312-313.
10. Bergen, A. R. and Franks, R. L., "Justification of the Describing Function Method," Siam Journal of Optimization and Control, vol. 9, no. 4, 1971, pp. 568-589.
11. Bergen, A. R. and Baker, A. R., "On Third Order Systems and Aizerman's Conjecture," IEEE Transactions on Automatic Control, vol. AC17, 1972, pp. 20-222.
12. Bezvodinskaya, T. A. and Sabaev, E. F., "Frequency Stability Criterion for a Variable Structure Automatic Control System," Automation and Remote Control, vol. 33, no. 7, July, 1972, pp. 1133-1137.
13. Bickart, T. A., "The Exponential Describing Function in the Analysis of Nonlinear Systems," IEEE Transactions on Automatic Control, Vol. AC11, 1966, pp. 491-497.

14. Bickart, T. A. and Prada, G., "Bounded Input Power-Bounded Output Power Stability Criteria," Automatica, vol. 7, 1971, pp. 261-264.
15. Blackmore, D., "The Describing Function for Bounded Nonlinearity," To Be Published.
16. Borges, C. A., Cesari, L. and Sanchez, D. A., "Functional Analysis and the Method of Harmonic Balance," Quarterly of Applied Mathematics, vol. 32, no. 4, January, 1975, pp. 457-464.
17. Braverman, E. M., Meerkov, S. M. and Pyatnitskii, E. S., "A Small Parameter in the Problem of Justifying the Harmonic Balance Method (In the Case of the Filter Hypothesis). I," Automation and Remote Control, vol. 36, no. 1, January, 1975, pp. 1-16.
18. Braverman, E. M., Meerkov, S. M. and Pyatnitskii, E. S., "A Small Parameter in the Problem of Justifying the Harmonic Balance Method (In the Case of the Filter Hypothesis). II," Automation and Remote Control, vol. 36, no. 2, February, 1975, pp. 189-196.
19. Braverman, E. M., Meerkov, S. M. and Pyatnitskii, E. S., "Conditions for Applicability of the Method of Harmonic Balance for Systems with Hysteresis Nonlinearity (In the Case of the Filter Hypothesis)," Automation and Remote Control, vol. 37, no. 11, November, 1976, pp. 1640-1650.
20. Brayton, R. K. and Tong, C. H., "Stability of Dynamical Systems: A Constructive Approach," IEEE Transactions on Circuits and Systems, vol. CAS26, no. 4, April, 1979, pp. 224-234.
21. Brockett, R. W. and Willems, J. L., "Frequency Domain Stability Criteria - Part I," IEEE Transactions on Automatic Control, vol. AC10, no. 3, 1965, pp. 255-261.
22. Brockett, R. W. and Willems, J. L., "Frequency Domain Stability Criteria - Part II," IEEE Transactions on Automatic Control, vol. AC10, no. 4, 1965, pp. 407-413.
23. Brockett, R. W., "The Status of Stability Theory for Deterministic Systems," IEEE Transactions on Automatic Control, vol. AC11, 1966, pp. 596-606.
24. Brockett, R. W. and Lee, H. B., "Frequency-Domain Instability Criteria for Time-Varying and Nonlinear Systems," Proceedings of the IEEE, vol. 55, no. 5, May, 1967, pp. 604-619.
25. Butenin, N. V., Elements of the Theory of Nonlinear Oscillations, New York: Blaisdell, 1960.
26. Butko, Y. A. and Shterenberg, Y. O., "Plots for Determining Periodic Regimes in Nonlinear Automatic Control Systems," Automation and Remote Control, vol. 29, no. 4, April, 1968, pp. 676-683.

27. Byrne, P. C. and Sheeran, M., "Comment on Geometric Criterion for the Absence of Limit Cycles in Nonlinear Control Systems," Electronics Letters, vol. 9, no. 24, November, 1973, p. 576.
28. Chandra, J. and Davis, P. W., "Closed-Form Approximation of the Periodic Response of a System with a Saturating Non-Linearity," International Journal of Control, vol. 18, no. 6, December, 1973, pp. 1221-1231.
29. Chernikov, S. A., "Extension of the Method of Harmonic Linearization to Nonlinear Systems with Nonfiltering Linear Parts," Engineering Cybernetics, vol. 21, no. 4, July, 1974, pp. 138-147.
30. Chien, Ming-Jeh, "Searching for Multiple Solutions of Nonlinear Systems," IEEE Transactions on Circuits and Systems, vol. CAS26, no. 10, October, 1979, pp. 817-827.
31. Cho, Y. S. and Narendra, K. S., "An Off-Axis Circle Criterion for Stability of Feedback Systems with a Monotonic Nonlinearity," IEEE Transactions on Automatic Control, vol. AC13, 1968, pp. 413-416.
32. Cho, Y. S. and Narendra, K. S., "Stability of Nonlinear Time-Varying Feedback Systems," Automatica, vol. 4, 1968, pp. 309-322.
33. Chua, L. O. and Green, D. N., "A Qualitative Analysis of the Behaviour of Dynamic Nonlinear Networks: Stability of Autonomous Networks," IEEE Transactions on Circuit Theory, vol. CAS23, no. 6, 1976, pp. 355-379.
34. Cook, P. A., "Describing Function for a Sector Nonlinearity," Proceedings of the IEE, vol. 120, no. 1, January, 1973, pp. 143-144.
35. Cook, P. A., "Circle Criteria for Stability in Hilbert Space," Siam Journal of Optimization and Control, vol. 13, no. 3, 1975, pp. 593-610.
36. Cronin, J., Fixed Points and Topological Degree in Functional Analysis, Providence, R. I.: American Mathematical Society, 1964.
37. Dasarathy, B. V. and Srinivasan, P., "On the Synthesis of Self-Oscillatory Systems," International Journal of Control, vol. 8, no. 1, July, 1968, pp. 97-100.
38. Davis, J. H., "Fredholm Operators, Encirclements and Stability Criteria," Siam Journal of Optimization and Control, vol. 10, no. 4, 1972, pp. 608-622.
39. Davison, E. J. and Kurak, E. M., "A Computational Method for Determining Quadratic Lyapunov Functions for Non-Linear Systems," Automatica, vol. 7, 1971, pp. 627-636.

40. De Figueiredo, R. J. P., "Forced Oscillations in Nonlinear Systems with Hysteresis," IEEE Transactions on Circuit Theory, vol. CT12, no. 1, 1965, pp. 52-58.
41. Desoer, C. A., "A Generalization of the Popov Criterion," IEEE Transactions on Automatic Control, vol. AC10, no. 2, 1965, pp. 182-185.
42. Desoer, C. A. and Wu, M. Y., "Stability of a Nonlinear Time-Invariant Feedback System Under Almost Constant Inputs," Automatica, vol. 5, 1969, pp. 231-233.
43. Dewey, A. G. and Jury, E. I., "A Stability Inequality for a Class of Nonlinear Feedback Systems," IEEE Transactions on Automatic Control, vol. AC11, no. 1, 1966, pp. 54-62.
44. Dewey, A. G., "On the Stability of Feedback Systems with one Differentiable Nonlinear Element," IEEE Transactions on Automatic Control, vol. AC11, 1966, pp. 485-491.
45. Duncan, C. W. and Johnson, R. A., "Error Bounds for the Describing Function Method," IEEE Transactions on Automatic Control, vol. AC13, 1968, pp. 730-732.
46. Épel'man, M. S., "A Criterion for the Absolute Stability of Nonlinear Sampled-Data Automatic Systems," Automation and Remote Control, vol. 27, no. 10, October, 1966, pp. 1724-1727.
47. Fitts, R. E., "Two Counterexamples to Aizerman's Conjecture," IEEE Transactions on Automatic Control, vol. AC11, 1966, pp. 553-556.
48. Freedman, M. I., Falb, P. L. and Zames, G., "A Hilbert Space Stability Theory Over Locally Compact Abelian Groups," Siam Journal of Optimization and Control, vol. 7, no. 3, 1969, pp. 479-495.
49. Freeman, E. and Eng, C., "Stability of Nonlinear Oscillations Predicted by Harmonic-Linearisation Technique," Proceedings of the IEE, vol. 115, no. 3, March, 1968, pp. 445-452.
50. Gaiduk, A. I., "Absolute Stability of Control Systems with Several Nonlinearities," Automation and Remote Control, vol. 37, no. 6, June, 1976, pp. 815-820.
51. Garber, E. D., "Error Estimation in the Describing Function Method," Automation and Remote Control, vol. 24, no. 4, November, 1963, pp. 449-458.
52. Garber, E. D. and Rozenvasser, E. N., "The Investigation of Periodic Regimes of Nonlinear Systems on the Basis of the Filter Hypothesis," Automation and Remote Control, vol. 26, no. 2, February, 1965, pp. 274-285.

53. Garg, D. P. and Geisler, E. G., "Limit Cycle Analysis for Control Systems of High Order," International Journal of Control, vol. 17, no. 6, June, 1973, pp. 1225-1232.
54. Gelb, A. and Vander Velde, W., Multiple-Input Describing Functions and Nonlinear System Design, New York: McGraw-Hill, 1968.
55. Geleg, A. K. H., "The Absolute Stability of Nonlinear Control Systems with Distributed Parameters," Automation and Remote Control, vol. 26, no. 3, March, 1965, pp. 395-403.
56. Gelig, A. K., "Investigation of Stability of Nonlinear Discontinuous Automatic Control Systems with a Nonunique Equilibrium State," Automation and Remote Control, vol. 25, no. 2, February, 1964, pp. 141-148.
57. Gelig, A. K. H. and Komarnitskaya, O. I., "Absolute Stability in Critical Cases of Nonlinear Systems with a Nonunique Equilibrium State," Automation and Remote Control, vol. 27, no. 8, August, 1966, pp. 1327-1336.
58. Gelig, A. K., "Stability of Control Systems with Bounded Nonlinearities," Automation and Remote Control, vol. 30, no. 11, November, 1969, pp. 1724-1731.
59. Gelik, A. K., "Stability of Multiconnected Nonlinear Controlled Systems with Nonunique Equilibrium Positions," Automation and Remote Control, vol. 31, no. 1, January, 1970, pp. 10-17.
60. Georgievskii, V. S., Levit, M. V. and Yakubovich, V. A., "Frequency Conditions of Autooscillations in Nonlinear Controlled Systems," Automation and Remote Control, vol. 33, no. 2, February, 1972, pp. 192-200.
61. Grumondz, V. T., "G. V. Kamenkov's Method as a Means of Justifying the Method of Harmonic Linearization," Automation and Remote Control, vol. 34, no. 6, June, 1973, pp. 983-985.
62. Gulchuk, G. G., "Frequency Conditions for Absolute Stability of Automatic Control Systems for Certain Classes of Nonlinearities," Automation and Remote Control, vol. 29, no. 9, September, 1968, pp. 1529-1533.
63. Haddad, E. K., "A Criterion for Bounded-Input, Bounded-Output Stability of Time-Varying Nonlinear Systems," Siam Journal of Optimization and Control, Vol. 11, no. 2, 1973, pp. 286-305.
64. Hale, J. K., Oscillations in Nonlinear Systems, New York: McGraw-Hill, 1963.
65. Hill, D. J. and Moylan, P. J., "Stability Results for Nonlinear Feedback Systems," Automatica, vol. 13, 1977, pp. 377-382.

66. Hirai, K., "A Stability Criterion of Nonlinear Control Systems," IEEE Transactions on Automatic Control, vol. AC14, 1969, pp. 601-602.
67. Holtzman, J. M., "Contraction Maps and Equivalent Linearization," Bell Systems Technical Journal, vol. 46, no. 10, December, 1967, pp. 2405-2435.
68. Holtzman, J. M., Nonlinear System Theory - A Functional Analysis Approach, Englewood Cliffs, N.J.: Prentice-Hall, 1970.
69. Hsu, J. C. and Meyer, A. U., Modern Control Principles and Applications, New York: McGraw-Hill, 1968.
70. Johnson, R. A. and Leach, B. W., "Stability of Oscillations in Low-Order Nonlinear Systems," IEEE Transactions on Automatic Control, vol. AC17, no. 10, October, 1972, pp. 672-675.
71. Judd, F. F., "Relationships Between Tsytkin, Hamel and Approximate Limit Cycle Analyses," International Journal of Control, vol. 21, no. 4, April, 1975, pp. 641-653.
72. Jumarie, G., "Generalization of the Theory of Ya. Z. Tsytkin for Relay Automatic Control Systems," Automation and Remote Control, vol. 30, no. 12, December, 1969, pp. 1929-1937.
73. Jury, E. I. and Lee, B. W., "The Absolute Stability of Systems with Many Nonlinearities," Automation and Remote Control, vol. 26, no. 6, June, 1965, pp. 943-961.
74. Kashiwagi, Y. and Flügge-Lotz, I., "Periodic Solutions of Differential-Difference Equations with Relay Control," International Journal of Control, vol. 6, no. 1, July, 1967, pp. 1-25.
75. Khalanai, A., "Absolute Stability of Certain Nonlinear Control Systems with Lags," Automation and Remote Control, vol. 25, no. 3, March, 1964, pp. 268-279.
76. Khalanai, A., "Absolute Stability of Nonlinear Control Systems with Delay Arguments," Automation and Remote Control, vol. 25, no. 10, October, 1964, pp. 1251-1256.
77. Kolmogorov, A. N. and Fomin, S. V., Elements of the Theory of Functions and Functional Analysis, Rochester, N.Y.: Graylock, 1957.
78. Kormanik, J. and Li, C. C., "Decision Surface Estimate of Nonlinear System Stability Domain by Lie Series Method," IEEE Transactions on Automatic Control, vol. AC17, no. 10, October, 1972, pp. 666-669.
79. Krasnosel'skii, M. A. and Lifschitz, E. A., "Some Criteria for the Existence of Periodic Oscillations in Nonlinear Systems," Automation and Remote Control, vol. 34, no. 9, September, 1973, pp. 1374-1377.

80. Krasnosel'skiy, M. A., Perov, A. I., Povolotskiy, A. I. and Zabreiko, P. P., Plane Vector Fields, New York: Academic Press, 1966.
81. Krener, A. J., "On the Equivalence of Control Systems and the Linearization of Nonlinear Systems," Siam Journal of Optimization and Control, vol. 11, no. 4, 1973, pp. 670-676.
82. Kudrewicz, J., "Stability of Nonlinear Systems with Feedback," Automation and Remote Control, vol. 25, no. 8, August, 1964, pp. 1027-1037.
83. LaSalle, J. and Lefschetz, S., Stability by Liapunov's Direct Method with Applications, New York: Academic Press, 1961.
84. Lefevre, C. and Richalet, J., "Energy Stability Criteria," Automation and Remote Control, vol. 29, no. 4, April, 1968, pp. 531-539.
85. Lellouche, G. S., "A Frequency Criterion for Oscillatory Solutions," Siam Journal of Optimization and Control, vol. 8, no. 2, 1970, pp. 202-206.
86. Le Maitre, J. F., Paquet, J. G. and Gille, J. C., "A General Approach for On-Off Control Systems Oscillations," Automatica, vol. 6, 1970, pp. 609-613.
87. Maigarin, B. Z., "On the Absolute Stability of Nonlinear Third-Order Automatic Control Systems," Automation and Remote Control, vol. 24, no. 6, January, 1964, pp. 772-777.
88. Maigarin, B. Z., "Certain Criteria for the Absolute Stability of Controlled Systems," Automation and Remote Control, vol. 31, no. 1, January, 1970, pp. 165-168.
89. Mandal, Z., Choudhury, D., Bhattacharyya, A., and Choudhury, A., "D.C. Gain of the Non-Linear Element and the Describing Function," International Journal of Control, vol. 12, no. 2, August, 1970, pp. 329-336.
90. McClamroch, N. H. and Ianculescu, G. D., "Global Stability of Two Linearly Interconnected Nonlinear Subsystems," IEEE Transactions on Automatic Control, vol. AC20, no. 10, October, 1975, pp. 678-682.
91. Mees, A. I., "Describing Functions, Circle Criteria and Multiple-Loop Feedback Systems," Proceedings of the IEE, vol. 120, no. 1, January, 1973, pp. 126-130.
92. Mees, A. I., "Periodic Waveforms in Forced Non-Linear Systems," International Journal of Control, vol. 18, no. 6, December, 1973, pp. 1169-1188.

93. Mees, A. I. and Bergen, A. R., "Describing Functions Revisited," IEEE Transactions on Automatic Control, vol. AC20, no. 4, 1975, pp. 473-478.
94. Mees, A. I. and Chua, L. O., "The Hopf Bifurcation Theorem and its Applications to Nonlinear Oscillations in Circuits and Systems," IEEE Transactions on Circuits and Systems, vol. CAS26, no. 4, April, 1979, pp. 235-254.
95. Meyer, A. U., "Some Fundamental Principles of Nonlinear Systems," in Nonlinear System Analysis and Synthesis, vol 11, J. K. Hedrick and H. M. Paynter, Editors, ASME 1978.
96. Michel, A. N., Miller, R. K. and Tang, W., "Lyapunov Stability of Interconnected Systems: Decomposition into Strongly Connected Subsystems," IEEE Transactions on Circuits and Systems, vol. CAS25, no. 9, September, 1978, pp. 799-809.
97. Miller, R. K. and Michel, A. N., "On Existence of Periodic Motions in Nonlinear Control Systems with Periodic Inputs," Siam Journal of Optimization and Control, vol. 18, no. 5, September, 1980, pp. 585-598.
98. Milnor, J. W., Topology from the Differentiable Point of View, Charlottesville: The University Press of Virginia, 1965.
99. Mindlin, I. M., "Stability of Automatic Control Systems with a Single Nonlinear Element," Automation and Remote Control, vol. 24, no. 3, October, 1963, pp. 368-372.
100. Minorsky, N., Nonlinear Oscillations, Princeton, N.J.: Van Nostrand, 1962.
101. Modina, E. S., Obabkov, V. K. and Kharchenko, V. P., "Self-Oscillating Processes in Nonlinear Automatic Control Systems," Automation and Remote Control, vol. 36, no. 1, January, 1975, pp. 17-23.
102. Moll, P. and Pandit, M., "On the Determination of Limit Cycles in Relay Control Systems with Additional Saturation Type Non-Linear Elements," International Journal of Control, vol. 10, no. 6, December, 1969, pp. 703-711.
103. Mukhametzyanov, I. A., and Serikbaev, S. S., "Necessary and Sufficient Conditions for the Absolute Stability of Certain Nonlinear Systems," Automation and Remote Control, vol. 31, no. 11, November, 1970, pp. 1726-1732.
104. Murphy, G. J., "A Frequency-Domain Stability Chart for Nonlinear Feedback Systems," IEEE Transactions on Automatic Control, vol. AC12, 1967, pp. 740-743.
105. Narendra, K. S. and Neuman, C. P., "Stability of a Class of Differential Equations with a Single Monotone Nonlinearity," Siam Journal of Optimization and Control, vol. 4, no. 2, 1966, pp. 295-308.

106. Narendra, K. S. and Cho, Y. S., "Stability of Feedback Systems Containing a Single Odd Monotonic Nonlinearity," IEEE Transactions on Automatic Control, vol. AC12, 1967, pp. 448-450.
107. Narendra, K. S. and Taylor, J. H., Frequency Domain Criteria for Absolute Stability, New York: Academic Press, 1973.
108. Naumov, B. N. and Tsytkin, YA. Z., "A Frequency Criterion for Absolute Process Stability in Nonlinear Automatic Control Systems," Automation and Remote Control, vol. 25, no. 6, June, 1964, pp. 765-778.
109. Naumov, B. N., "An Investigation of Absolute Stability of the Equilibrium State in Nonlinear Automatic Control Systems by Means of Logarithmic Frequency Characteristics," Automation and Remote Control, vol. 26, no. 4, April, 1965, pp. 593-601.
110. Nelepin, R. A., "Question of an Exact Boundary of the Absolute Stability Region of Controlled Systems," Automation and Remote Control, vol. 28, no. 4, April, 1967, pp. 555-561.
111. Noldus, E., "A Frequency Domain Approach to the Problem of the Existence of Periodic Motion in Autonomous Nonlinear Feedback Systems," Zeitschrift Für Angewandte Mathematik Und Mechanik, vol. 49, no. 3, March, 1969, pp. 167-177.
112. Noldus, E., "A Counterpart of Popov's Theorem for the Existence of Periodic Solutions," International Journal of Control, vol. 13, no. 4, April, 1971, pp. 705-719.
113. Noldus, E., "On the Instability of Nonlinear Systems," IEEE Transactions on Automatic Control, vol. AC18, 1973, pp. 404-405.
114. Noldus, E. J. L., "Autonomous Periodic Motion in Nonlinear Feedback Systems," IEEE Transactions on Automatic Control, vol. AC19, no. 4, 1974, pp. 381-387.
115. Noldus, E. J. L., "Oscillation Criteria of the Popov Type," IEEE Transactions on Automatic Control, vol. AC20, 1975, pp. 577-579.
116. Noldus, E., "Instability Criteria for Time-Varying Nonlinear Functional Differential Systems," Siam Journal of Optimization and Control, vol. 13, no. 2, 1975, pp. 420-433.
117. Ortega, J. M. and Rheinboldt, W. C., Iterative Solution of Nonlinear Equations in Several Variables, New York: Academic Press, 1970.

118. O'Shea, R. P., "A Combined Frequency-Time Domain Stability Criterion for Autonomous Continuous Systems," IEEE Transactions on Automatic Control, vol. AC11, 1966, pp. 477-484.
119. O'Shea, R. P., "An Improved Frequency Time Domain Stability Criterion for Autonomous Continuous Systems," IEEE Transactions on Automatic Control, vol. AC12, 1967, pp. 725-731.
120. Partovi, S. and Nahi, N. E., "Absolute Stability of Dynamic Systems Containing Non-Linear Functions of Several State Variables," Automatica, vol. 5, 1969, pp. 465-473.
121. Pliss, V. A., Nonlocal Problems of the Theory of Oscillations, New York: Academic Press, 1966.
122. Popov, A. K., "A Method of Analyzing Self-Oscillations in Automatic Systems," Automation and Remote Control, vol. 27, no. 11, November, 1966, pp. 1973-1976.
123. Popov, V. M., "Absolute Stability of Nonlinear Systems of Automatic Control," Automation and Remote Control, vol. 22, no. 8, March, 1962, pp. 857-875.
124. Popov, V. M., "A Critical Case of Absolute Stability," Automation and Remote Control, vol. 23, no. 1, June, 1962, pp. 1-21.
125. Popov, V. M. and Halany, A., "On the Stability of Nonlinear Automatic Control Systems with Lagging Arguments," Automation and Remote Control, vol. 23, no. 7, February, 1963, pp. 783-786.
126. Popov, V. M., "The Solution of a new Stability Problem for Controlled Systems," Automation and Remote Control, vol. 24, no. 1, September, 1963, pp. 1-23.
127. Popov, V. M., "One Problem in the Theory of Absolute Stability of Controlled Systems," Automation and Remote Control, vol. 25, no. 9, September, 1964, pp. 1129-1134.
128. Power, H. M. and Tsoi, A. C., "A Note on Brockett's Variational Technique and a Conjecture in Stability Theory," IEEE Transactions on Automatic Control, vol. AC19, no. 3, 1974, pp. 251-252.
129. Protter, M. and Morrey, Jr., C., Modern Mathematical Analysis, Reading, Mass.: Addison-Wesley, 1964.
130. Prusty, S., "A New Approach for the Study of Limit-Cycle Behaviour for a Class of Third-Order Non-Linear Control Systems," International Journal of Control, vol. 12, no. 2, August, 1970, pp. 257-263.

131. Pyatnitskii, E. S., "New Research on the Absolute Stability of Control Systems," Automation and Remote Control, vol. 29, no. 6, June, 1968, pp. 855-881.
132. Pyatnitskii, E. S., "Existence of Absolutely Stable Systems for Which the Popov Criterion Fails," Automation and Remote Control, vol. 34, no. 1, January, 1973, pp. 22-29.
133. Rapp, P. E. and Mees, A. I., "Spurious Predictions of Limit Cycles in a Non-Linear Feedback System by the Describing Function Method," International Journal of Control, vol. 26, no. 6, December, 1977, pp. 821-829.
134. Rasis, Y. and Bonen, Z., "Oscillations in a Two-Dimensional Non-Linear System," International Journal of Control, vol. 14, no. 1, July, 1971, pp. 129-139.
135. Rekasius, Z. V. and Rowland, J. R., "A Stability Criterion for Feedback Systems Containing a Single Time-Varying Nonlinear Element," IEEE Transactions on Automatic Control, vol. AC10, no.3, 1965, pp. 352-353
136. Rootenberg, J. and Walk, R., "Geometric Criterion for the Absence of Limit Cycles in Nonlinear Control Systems," Electronics Letters, vol. 8, no. 20, October, 1972, pp. 497-499.
137. Rootenberg, J. and Walk, R., "Frequency Criteria for the Absence of Limit Cycles in Nonlinear Systems," IEEE Transactions on Automatic Control, vol. AC18, no. 1, 1973, pp. 64-65.
138. Rozenvasser, E. N., "The Absolute Stability of Nonlinear Systems," Automation and Remote Control, vol. 24, no. 2, March, 1963, pp. 283-291.
139. Rozenvasser, E. N., "Stability Criteria of Nonlinear Discrete Systems," Automation and Remote Control, vol. 27, no. 12, December, 1966, pp. 2053-2062.
140. Sandberg, I. W., "On the L₂-Boundedness of Solutions of Nonlinear Functional Equations," Bell Systems Technical Journal, vol. 43, no. 4, July, 1964, pp. 1581-1599.
141. Sandberg, I. W., "A Frequency-Domain Condition for the Stability of Feedback Systems Containing a Single Time-Varying Non-linear Element," Bell Systems Technical Journal, vol. 43, no. 4, July, 1964, pp. 1601-1608.
142. Sandberg, I. W., "A Condition for the L_∞ Stability of Feedback Systems Containing a Single Time-Varying Nonlinear Element," Bell Systems Technical Journal, vol. 43, no. 4, July, 1964, pp. 1815-1817.
143. Sandberg, I. W., "On the Response of Nonlinear Control Systems to Periodic Input Signals," Bell Systems Technical Journal, vol. 43, no. 3, May, 1964, pp. 911-926.

144. Sandberg, I. W., "A Note on the Application of the Contraction-Mapping Fixed-Point Theorem to a Class of Nonlinear Functional Equations," Siam Review, vol. 7, no. 2, April, 1965, pp. 199-204.
145. Sandberg, I. W., "An Observation Concerning the Application of the Contraction-Mapping Fixed-Point Theorem, and a Result Concerning the Norm-Boundedness of Solutions of Nonlinear Functional Equations," Bell Systems Technical Journal, vol. 44, no. 8, October, 1965, pp. 1809-1812.
146. Sandberg, I. W., "On Generalizations and Extensions of the Popov Criterion," IEEE Transactions on Circuit Theory, vol. CT13, no. 1, 1966, pp. 117-118.
147. Sea, R. G. and Vacroux, A. G., "Steady State Analysis and Multiple Input Describing Functions (MIDF)," Automatica, vol. 5, 1969, pp. 763-772.
148. Sen, A. K., "A Simpler Stability Criterion for a Class of Nonlinear Systems," IEEE Transactions on Automatic Control, vol. AC13, 1968, pp. 451-452.
149. Shil'nikov, L. P., "Theory of the Bifurcation of Dynamical Systems and Dangerous Boundaries," Soviet Physics Doklady, vol. 20, no. 10, October, 1975, pp. 674-676.
150. Siljak, D., "Parameter Analysis of Absolute Stability," Automatica, vol. 5, 1969, pp. 385-387.
151. Singh, V., "A Counterexample to Harmonic Linearization," Proceedings of the IEEE, vol. 63, no. 11, November, 1975, p. 1610.
152. Skoog, R. A., "Positivity Conditions and Instability Criteria for Feedback Systems," Siam Journal of Optimization and Control, vol. 12, no. 1, 1974, pp. 83-98.
153. Steding, T. L. and Bergen, A. R., "Instability of Nonlinear Infinite-Dimensional Feedback Systems Using Lyapunov Functionals," Siam Journal of Optimization and Control, vol. 12, no. 4, 1974, pp. 664-678.
154. Stoich, M. R., "Algebraic Criterion for Process and Equilibrium State Absolute Stability in Nonlinear Continuous Automatic Control Systems," Automation and Remote Control, vol. 30, no. 8, August, 1969, pp. 1189-1198.
155. Sultanov, I. A., "Resolution Equations for the Investigation of Absolute Stability of Control Systems with Many Control Elements," Automation and Remote Control, vol. 25, no. 2, February, 1964, pp. 149-154.
156. Sundareshan, M. K. and Thathachar, M. A. L., "L2 Stability of Nonstationary Feedback Systems: Frequency Domain Criteria," IEEE Transactions on Automatic Control, vol. AC19, no. 3, 1974, pp. 217-224.

157. Teverovskii, V. I., "Method for Analyzing Periodic Operating Conditions in Relay Systems Containing two Arbitrarily Connected Relays," Automation and Remote Control, vol. 25, no. 3, March, 1964, pp. 315-322.
158. Thathachar, M. A. L. and Srinath, M. D., "Some Aspects of the Lur'e Problem," IEEE Transactions on Automatic Control, vol. AC12, 1967, pp. 451-453.
159. Thathachar, M. A. L., Srinath, M. D. and Ramapriyan, H. K., "On a Modified Lur'e Problem," IEEE Transactions on Automatic Control, vol. AC12, 1967, pp. 731-740.
160. Thathachar, M. A. L. and Srinath, M. D., "An Improved Stability Criterion for a System with a Non-Monotone Non-Linearity," International Journal of Control, vol. 12, no. 1, July, 1970, pp. 145-155.
161. Thathachar, M. A. L., "Stability of Systems with Power-Law Non-Linearities," Automatica, vol. 6, 1970, pp. 721-730.
162. Thathachar, M. A. L. and Sundareshan, M. K., "A Generalised Stability Multiplier," Automatica, vol. 7, 1971, pp. 111-112.
163. Towle, H. C. and Kazda, L. F., "Contraction Mapping Applicable to Certain Nonlinear Closed-Loop Systems," IEEE Transactions on Automatic Control, vol. AC15, 1970, pp. 274-275.
164. Trick, T. N. and Anderson, D. R., "Stability of Nonlinear Networks," IEEE Transactions on Circuit Theory, vol. CT16, no. 3, 1969, pp. 302-311.
165. Tsytkin, Ya. Z., "Frequency Criteria for the Absolute Stability of Nonlinear Sampled-Data Systems," Automation and Remote Control, vol. 25, no. 3, March, 1964, pp. 261-267.
166. Tsytkin, Ya. Z., "Absolute Stability of a Class of Nonlinear Automatic Sampled Data Systems," Automation and Remote Control, vol. 25, no. 7, July 1964, pp. 918-923.
167. Venkatesh, "Global Variation Criteria for the L2 Stability of Nonlinear Time Varying Systems," Siam Journal of Mathematical Analysis, vol. 9, no. 3, 1978, pp. 568-581.
168. Voronov, A. A., "Absolutely Stable Systems with a Differentiable Nondecreasing Nonlinearity," Automation and Remote Control, vol. 39, no. 7, July, 1978, pp. 947-952.
169. Vyong, Ngo Van, "Absolute Stability of Controlled Systems with two Executive Organs in a Critical Case," Automation and Remote Control, vol. 29, no. 1, January, 1968, pp. 17-24.

170. Weischedel, H. R., "An Exact Method for the Analysis of Limit Cycles in On-Off Control Systems," IEEE Transactions on Automatic Control, vol. AC18, no. 1, 1973, pp. 40-44.
171. Willems, J. C., "Stability, Instability, Invertability, and Causality," Siam Journal of Optimization and Control, vol. 7, no. 4, 1969, pp. 645-671.
172. Willems, J. L., "The Stability of Oscillations in Nonlinear Networks," IEEE Transactions on Circuit Theory, vol. CT15, no. 3, 1968, pp. 284-286.
173. Willems, J. L., "The Computation of Finite Stability Regions by Means of Open Liapunov Surfaces," International Journal of Control, vol. 10, no. 5, November, 1969, pp. 537-544.
174. Willems, J. L., Stability Theory of Dynamical Systems, New York: Wiley, 1970.
175. Williamson, D., "Periodic Motion in Nonlinear Systems," IEEE Transactions on Automatic Control, vol. AC20, no. 4, 1975, pp. 479-486.
176. Williamson, D., "Describing Function Analysis and Oscillations in Non-Linear Networks," International Journal of Control, vol. 24, no. 2, August, 1976, pp. 283-296.
177. Wu, M. Y. and Desoer, C. A., " L^p -Stability ($1 \leq p \leq \infty$) of Nonlinear Time-Varying Feedback Systems," Siam Journal of Optimization and Control, vol. 7, no. 2, 1969, pp. 356-364.
178. Yakubovich, V. A., "Absolute Stability of Control Systems in Critical Cases I," Automation and Remote Control, vol. 24, no. 3, October, 1963, pp. 273-281.
179. Yakubovich, V. A., "Absolute Stability of Nonlinear Control Systems in Critical Cases II," Automation and Remote Control, vol. 24, no. 6, January, 1964, pp. 655-668.
180. Yakubovich, V. A., "The Absolute Stability of Nonlinear Control Systems in Critical Cases III," Automation and Remote Control, vol. 25, no. 5, May, 1964, pp. 545-556.
181. Yakubovich, V. A., "The Matrix-Inequality Method in the Theory of the Stability of Nonlinear Control Systems I. The Absolute Stability of Forced Vibrations," Automation and Remote Control, vol. 25, no. 7, July, 1964, pp. 905-917.
182. Yakubovich, V. A., "The Method of Matrix Inequalities in the Stability Theory of Nonlinear Control Systems II. Absolute Stability in a Class of Nonlinearities with a Condition on the Derivative," Automation and Remote Control, vol. 26, no. 4, April, 1965, pp. 577-592.

183. Yakubovich, V. A., "The Method of Matrix Inequalities in the Theory of Stability of Non-Linear Controlled Systems III. Absolute Stability of Systems with Hysteresis Non-Linearities," Automation and Remote Control, vol. 26, no. 5, May, 1965, pp. 753-763.
184. Yakubovich, V. A., "Frequency Conditions for the Absolute Stability of Control Systems with Several Nonlinear or Linear Nonstationary Blocks," Automation and Remote Control, vol. 28, no. 6, June, 1967, pp. 857-879.
185. Yakubovich, V. A., "Absolute Stability of Nonlinear Control Systems I. General Frequency Criteria," Automation and Remote Control, vol. 31, no. 12, December, 1970, pp. 1903-1911.
186. Yakubovich, V. A., "Absolute Instability of Nonlinear Control Systems. II. Systems with Nonstationary Nonlinearities. The Circle Criterion," Automation and Remote Control, vol. 32, no. 6, June, 1971, pp. 876-884.
187. Yakubovich, V. A., "Frequency Conditions of Oscillations in Non-linear Control Systems with one Single-Valued or Hysteresis-Type Nonlinearity," Automation and Remote Control, vol. 36, no. 12, December, 1975, pp. 1973-1984.
188. Zaghoul, M. E. and Bryant, P. R., "Error Bounds on Solutions of Nonlinear Networks when Using Approximate Element Characteristics," IEEE Transactions on Circuits and Systems, vol. CAS27, no. 1, January, 1980, pp. 20-29.
189. Zames, G., "On the Input-Output Stability of Time-Varying Nonlinear Feedback Systems - Part I: Conditions Derived Using Concepts of Loop Gain, Conicity, and Positivity," IEEE Transactions on Automatic Control, vol. AC11, no. 2, 1966, pp. 228-238.
190. Zames, G., "On the Input-Output Stability of Time-Varying Nonlinear Feedback Systems - Part II: Conditions Involving Circles in the Frequency Plane and Sector Nonlinearities," IEEE Transactions on Automatic Control, vol. AC11, no. 3, 1966, pp. 465-476.
191. Zames, G. and Falb, P. L., "Stability Conditions for Systems with Monotone and Slope-Restricted Nonlinearities," Siam Journal of Optimization and Control, vol. 6, no. 1, 1968, pp. 89-107.
192. Zames, G., "Stability of Systems with Sector Nonlinearities: A Comparison of Various Inequalities," IEEE Transactions on Automatic Control, vol. AC10, no. 6, December, 1968, pp. 709-711.
193. Zhukov, V. P., "Method of Qualitative Stability Analysis of Non-linear Systems," Automation and Remote Control, vol. 39, no. 6, June, 1978, pp. 785-788.