

# Analysis of SHA-512/224 and SHA-512/256

Christoph Dobraunig, Maria Eichlseder, and Florian Mendel

Graz University of Technology, Austria  
maria.eichlseder@iaik.tugraz.at

**Abstract.** In 2012, NIST standardized SHA-512/224 and SHA-512/256, two truncated variants of SHA-512, in FIPS 180-4. These two hash functions are faster than SHA-224 and SHA-256 on 64-bit platforms, while maintaining the same hash size and claimed security level. So far, no third-party analysis of SHA-512/224 or SHA-512/256 has been published. In this work, we examine the collision resistance of step-reduced versions of SHA-512/224 and SHA-512/256 by using differential cryptanalysis in combination with sophisticated search tools. We are able to generate practical examples of free-start collisions for 44-step SHA-512/224 and 43-step SHA-512/256. Thus, the truncation performed by these variants on their larger state allows us to attack several more rounds compared to the untruncated family members. In addition, we improve upon the best published collisions for 24-step SHA-512 and present practical collisions for 27 steps of SHA-512/224, SHA-512/256, and SHA-512.

**Keywords:** hash functions · cryptanalysis · collisions · free-start collisions · SHA-512/224 · SHA-512/256 · SHA-512 · SHA-2

## 1 Introduction

The SHA-2 family of hash functions is standardized by NIST as part of the Secure Hash Standard in FIPS 180-4 [17]. This standard is not superseded by the upcoming SHA-3 standard. Rather, the SHA-3 hash functions supplement the SHA-2 family. Thus, it is likely that the SHA-2 family will remain as ubiquitously deployed in the foreseeable future as it is now. Therefore, the continuous application of state-of-the-art cryptanalytic techniques for quantifying the security margin of hash functions of the SHA-2 family is of significant practical importance.

In this work, we focus on the two most recent members of the SHA-2 family, SHA-512/224 and SHA-512/256. As already observed by Gueron et al. [7], using truncated SHA-512 variants like SHA-512/256 gives a significant performance advantage over SHA-256 on 64-bit platforms due to the doubled input block size. At the same time, the shorter 256-bit hash values are more economic, compatible with existing applications, and offer the same security level as SHA-256. In addition, the resulting chop-MD [3] structure of SHA-512/224 and SHA-512/256 with its wide-pipe structure provides cryptographic benefits over the standard

Merkle-Damgård [4,16] structure by prohibiting generic attacks like Joux’ multi-collision attack [9], Kelsey and Kohno’s herding and Nostradamus attacks [10], and Kelsey and Schneier’s second preimages for long messages [11].

However, no cryptanalysis dedicated to SHA-512/224 and SHA-512/256 has been published so far. Therefore, we examine the effects of truncating the hash value of SHA-512. We show that due to this truncation, practical free-start collision for 43-step SHA-512/256 and 44-step SHA-512/224 are possible. Moreover, we improve upon the previous best collisions for 24-step SHA-512 [8,19] and show collisions for 27 steps of SHA-512, SHA-512/224, and SHA-512/256. We also include new results for the older truncated SHA-2 variants, SHA-224 and SHA-384. Since all of our results are practical, we provide examples of colliding message pairs for every attack. Our results are summarized in Table 1 together with previously published collision attacks.

**Table 1.** Best published collision attacks on the SHA-2 family.

State size	Hash size	Type	Steps	Complexity	Reference
512	all	collision	24/80	practical	[8,19]
		<b>collision</b>	<b>27/80</b>	<b>practical</b>	<b>Sect. 4.3</b>
		semi-free-start collision	38/80	practical	[6]
		<b>semi-free-start collision</b>	<b>39/80</b>	<b>practical</b>	<b>Sect. 4.1</b>
	512	free-start collision	57/80	$2^{255.5}$	[13]
	384	free-start collision	40/80	$2^{183}$	[13]
		<b>free-start collision*</b>	<b>41/80</b>	<b>practical</b>	<b>Sect. 4.2</b>
	256	<b>free-start collision*</b>	<b>43/80</b>	<b>practical</b>	<b>Sect. 4.2</b>
	224	<b>free-start collision*</b>	<b>44/80</b>	<b>practical</b>	<b>Sect. 4.2</b>
	256	all	<b>collision</b>	<b>28/64</b>	<b>practical</b>
collision			31/64	$2^{65.5}$	[15]
semi-free-start collision			38/64	practical	[15]
256		free-start collision	52/64	$2^{127.5}$	[13]
224		free-start collision	40/64	$2^{110}$	[13]
		<b>free-start collision*</b>	<b>39/64</b>	<b>practical</b>	<b>Sect. 4.2</b>

\* without padding.

**Related work.** No dedicated cryptanalysis of SHA-512/224 or SHA-512/256 has been published so far. However, there is a number of results targeting SHA-512. The security of SHA-512 against preimage attacks was first studied by Aoki et al. [1]. They presented MITM preimage attacks on 46 steps of the hash function. This was later extended to 50 steps by Khovratovich et al. [12]. However,

due to the wide-pipe structure of SHA-512/224 and SHA-512/256, these attacks do not carry over to SHA-512/224 and SHA-512/256.

The currently best known practical collision attack on the SHA-512 hash function is for 24 steps. It was published independently by Indestege et al. [8] and by Sanadhya and Sarkar [19]. Both attacks are trivial extensions of the attack strategy of Nikolić and Biryukov [18] which applies to both SHA-256 and SHA-512. Recently, Eichlseder et al. [6] demonstrated how to extend these attacks to get semi-free-start collisions for SHA-512 reduced to 38 steps with practical complexity. Furthermore, second-order differential collisions for SHA-512 up to 48 steps with practical complexity have been shown by Yu et al. [22]. We want to note that all these practical collision attacks on SHA-512 are also applicable to its truncated variants.

Additionally, Li et al. showed in [13] that particular preimage attacks on SHA-512 can also be used to construct free-start collision attacks for the step-reduced hash function and its truncated variants. They show a free-start collision for 57-step SHA-512 and 40-step SHA-384. Both attacks are only slightly faster than the respective generic attacks.

**Outline.** The remainder of the paper is organized as follows. We describe the design of the SHA-2 family in Sect. 2. Then, we briefly explain our attack strategy and discuss the choice of suitable starting points for our attacks in Sect. 3. The actual attacks on step-reduced SHA-512/224 and SHA-512/256 are presented in Sect. 4.

## 2 Description of SHA-512 and other SHA-2 variants

The SHA-2 family of hash functions is specified by NIST as part of the Secure Hash Standard (SHS) [17]. The standard defines two main algorithms, SHA-256 and SHA-512, with truncated variants SHA-224 (based on SHA-256) and SHA-512/224, SHA-512/256, and SHA-384 (based on SHA-512). In addition, NIST defines a general truncation procedure for arbitrary output lengths up to 512 bits. Below, we first describe SHA-512, followed by its truncated variants SHA-512/224 and SHA-512/256 that this paper is focused on. Finally, the main differences to SHA-256 and SHA-224 are briefly discussed.

**SHA-512.** SHA-512 is an iterated hash function that pads and processes the input message using  $t$  1024-bit message blocks  $m_j$ . The 512-bit hash value is computed using the compression function  $f$ :

$$\begin{aligned} h_0 &= \text{IV}, \\ h_{j+1} &= f(h_j, m_j) \quad \text{for } 0 \leq j < t. \end{aligned}$$

The hash output is the final 512-bit chaining value  $h_t$ .

In the following, we briefly describe the compression function  $f$  of SHA-512. It basically consists of two parts: the message expansion and the state update transformation. A more detailed description of SHA-512 is given by NIST [17].

We use  $+$  (or  $-$ ) to denote addition (or subtraction) modulo  $2^{64}$ ;  $\oplus$  (or  $\wedge$ ) is bitwise exclusive-or (or bitwise and) of 64-bit words, and  $\ggg n$  (or  $\gg n$ ) denotes rotate-right (or shift-right) by  $n$  bits.

**Padding and message expansion.** The message expansion of SHA-512 splits each 1024-bit message block into 16 64-bit words  $M_i$ ,  $i = 0, \dots, 15$ , and expands these into 80 expanded message words  $W_i$  as follows:

$$W_i = \begin{cases} M_i & 0 \leq i < 16, \\ \sigma_1(W_{i-2}) + W_{i-7} + \sigma_0(W_{i-15}) + W_{i-16} & 16 \leq i < 80. \end{cases} \quad (1)$$

The functions  $\sigma_0(x)$  and  $\sigma_1(x)$  are given by

$$\begin{aligned} \sigma_0(x) &= (x \ggg 1) \oplus (x \ggg 8) \oplus (x \gg 7), \\ \sigma_1(x) &= (x \ggg 19) \oplus (x \ggg 61) \oplus (x \gg 6). \end{aligned}$$

**State update transformation.** We use the alternative description of the SHA-512 state update by Mendel et al. [14], which is illustrated in Fig. 1.

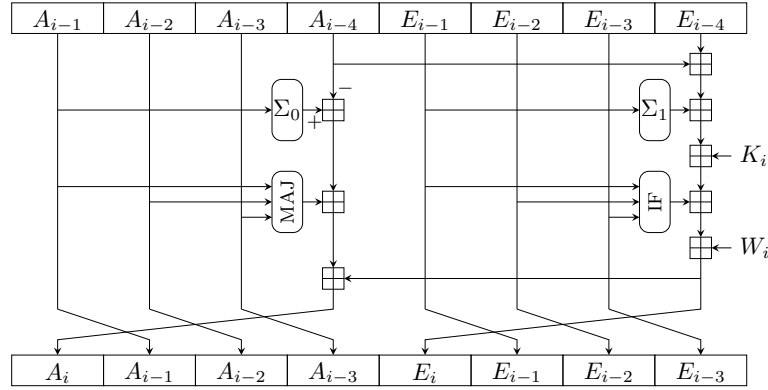

**Fig. 1.** The state update transformation of SHA-512.

The state update transformation starts from the previous 512-bit chaining value  $h_j = (A_{-1}, \dots, A_{-4}, E_{-1}, \dots, E_{-4})$  and updates it by applying the step functions 80 times. In each step  $i = 0, \dots, 79$ , one 64-bit expanded message word  $W_i$  is used to compute the two state variables  $E_i$  and  $A_i$  as follows:

$$E_i = A_{i-4} + E_{i-4} + \Sigma_1(E_{i-1}) + \text{IF}(E_{i-1}, E_{i-2}, E_{i-3}) + K_i + W_i, \quad (2)$$

$$A_i = E_i - A_{i-4} + \Sigma_0(A_{i-1}) + \text{MAJ}(A_{i-1}, A_{i-2}, A_{i-3}). \quad (3)$$

For the definition of the step constants  $K_i$ , we refer to the standard document [17]. The bitwise Boolean functions IF and MAJ used in each step are defined by

$$\begin{aligned}\text{IF}(x, y, z) &= (x \wedge y) \oplus (x \wedge z) \oplus z, \\ \text{MAJ}(x, y, z) &= (x \wedge y) \oplus (y \wedge z) \oplus (x \wedge z),\end{aligned}$$

and the linear functions  $\Sigma_0$  and  $\Sigma_1$  are defined as follows:

$$\begin{aligned}\Sigma_0(x) &= (x \ggg 28) \oplus (x \ggg 34) \oplus (x \ggg 39), \\ \Sigma_1(x) &= (x \ggg 14) \oplus (x \ggg 18) \oplus (x \ggg 41).\end{aligned}$$

After the last step of the state update transformation, the previous chaining value is added to the output of the state update (Davies-Meyer construction). The result of this feed-forward sum is the chaining value  $h_{j+1}$  for the next message block  $m_{j+1}$  (or the final hash value  $h_t$ ):

$$h_{j+1} = (A_{79} + A_{-1}, \dots, A_{76} + A_{-4}, E_{79} + E_{-1}, \dots, E_{76} + E_{-4}). \quad (4)$$

**SHA-384, SHA-512/256, and SHA-512/224.** These truncated variants of SHA-512 differ only in their initial values and a final truncation to 384, 256, or 224 bits, respectively. The rest of the algorithmic description remains exactly the same. The message digest of SHA-512/256 is obtained by omitting the output words  $E_{79} + E_{-1}$ ,  $E_{78} + E_{-2}$ ,  $E_{77} + E_{-3}$ , and  $E_{76} + E_{-4}$  of the last compression function call. SHA-512/224 additionally omits the 32 least significant bits of  $A_{76} + A_{-4}$ . SHA-384 omits the two words  $E_{77} + E_{-3}$  and  $E_{76} + E_{-4}$ .

**SHA-256 and SHA-224.** SHA-256 and SHA-512 are closely related. Thus, we only point out properties of SHA-256 which differ from SHA-512:

- The wordsize is 32 instead of 64 bits.
- IV and  $K_i$  are the 32 most significant bits of the respective SHA-512 value.
- The step function is applied 64 instead of 80 times.
- The linear functions  $\sigma_0$ ,  $\sigma_1$ ,  $\Sigma_0$  and  $\Sigma_1$  use different rotation values.

SHA-224 is a truncated variant of SHA-256 with different IV, in which the output word  $E_{60} + E_{-4}$  is omitted.

### 3 Attack strategy

Starting from the ground-breaking results of Wang et al. [20,21], the search techniques used for practical collisions have been significantly improved, hitting their current peak in the attacks on SHA-256 [2,15] and SHA-512 [6,22]. In spite of all achieved improvements, the top-level attack strategy has remained essentially the same. At first, a suitable starting point for the search must be determined to define the search space and hopefully make the ensuing search process feasible. The search itself usually involves two phases: The search for

a suitable differential characteristic, and the message modification phase to determine a collision-producing message pair for this characteristic. The search for this characteristic and message pair can either be done by hand or, for more complex functions like SHA-2, using an automatic search tool. We use a heuristic search tool based on a guess-and-determine strategy, which we briefly describe in Sect. 3.1. Afterwards, we discuss the choice of suitable starting points in Sect. 3.2.

### 3.1 Guess-and-determine search tool

To search for differential characteristics and colliding message pairs, we use an automatic search tool, which implements a configurable heuristic guess-and-determine search strategy. Roughly, the tool is partitioned into two separate, but closely interacting parts: The representation of the analyzed cryptographic primitive and the search procedure.

**Representation.** The tool internally represents differences at bit level, allowing to store all possible stages from a completely unrestricted bit over signed differences down to exact values. Thus, the same tool can be used in the search for a characteristic and in the search for a message pair. The conditions are grouped in words representing the internal variables of the hash function. These words can then be connected with any operations (typically bitwise functions or modular additions) to define the hash function.

**Search.** The search procedure uses the bitwise conditions as variables, and attempts to find a solving assignment with the help of a heuristic guess-and-determine strategy [5], similar to SAT solvers. The following steps are repeated until a solution is found:

- **Guess:** Pick a bit and guess its value (e.g., no difference, or a specific assignment).
- **Determine:** The previous guess influences other connected bit conditions. Determine these effects, which might result in further refinement of other bit conditions, or a contradiction.
- **Backtrack:** If a contradiction is detected, resolve this conflict by undoing previous guesses and replacing them with other choices.

This simple approach alone is not sufficient to go through the whole search space, so numerous refinements have been proposed to fine-tune this method. These include the detection of two-bit conditions [14], backtracking strategies, and a look-ahead approach to guide the search [6]. Additionally, SHA-2-specific heuristics and strategies [14,15] have been proposed, deciding which parts of the state to guess with higher priority. We refer to Appendix A for a more detailed description of the search tool.

### 3.2 Finding starting points for SHA-2

To model SHA-2 as a satisfiability problem for the search tool, we need to introduce suitable intermediate variables. Based on the alternative description from Sect. 2, we only use the words  $A_i$  and  $E_i$  of the state, plus the words  $W_i$  of the message expansion. Fig. 2 illustrates the update rules for  $A$ ,  $E$  and  $W$  by highlighting the input words for updating each word: Each row represents one of the 80 step iterations, with its three state words  $A_i$ ,  $E_i$ , and  $W_i$ .

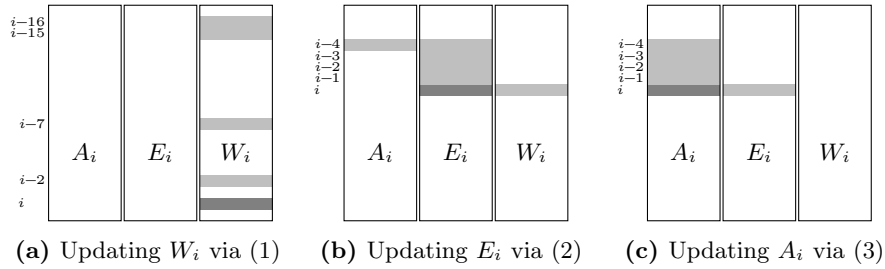

**Fig. 2.** Update rules to compute  $A_i$ ,  $E_i$ , and  $W_i$  (■) from other state words (▒).

**Local collisions.** All our results are based on “local collisions” in the message expansion: by carefully selecting (expanded) message words in the middle steps so that the differences can cancel out in as many consecutive steps as possible in the forward and backward expansion, i.e., the first and last few expanded message words contain no differences. The  $t$  middle steps with differences can induce differences in the  $A_i$  and  $E_i$  words. However, the  $W_i$  words can be used to achieve zero difference in the last 4 of the  $t$  words  $E_i$ , and in the last 8 of the  $t$  words  $A_i$ . This is necessary to obtain words with zero difference in the very last 4 steps of the state update and thus in the output chaining value.

As an example, the starting point for the 27-step collisions for SHA-256 [14] allows differences in expanded message words  $W_7, W_8, W_{12}, W_{15}$ , and  $W_{17}$ , as well as state words  $E_7, \dots, E_{13}$  and  $A_7, \dots, A_{10}$ . The exact bitwise signed differences are chosen during the search such that any potential differences in  $W_{19}, W_{22}, W_{23}, W_{24}$ , as well as  $E_{14}, \dots, E_{17}$  and  $A_{10}, \dots, A_{13}$  cancel out. The resulting starting point is illustrated in Fig. 3a. We show in Sect. 4.3 how the same starting point can be used for SHA-512. In addition, we use the closely related starting point for 28-step SHA-256 collisions [15], illustrated in Fig. 3b, to also find collisions for SHA-224.

The semi-free-start collision starting point covering the most steps so far is for 38 steps of SHA-256 [15] and SHA-512 [6], with a local collision spanning  $t = 18$  steps, as illustrated in Fig. 3c. Considering the large number of steps, the number of expanded message words with differences and cancellations is remarkably low: only 6 words with differences, and 6 words imposing cancellation conditions.

To find candidates for a higher number of steps, we enumerated all possible selections of active message words (more precisely, of some  $t \leq 20$  intermediate expanded message words, the “core words” of the local collision) and investigated the forward and backward expansion under certain assumptions: the  $t$  core words are chosen freely, according to the message expansion rule; in the forward and backward expansion, if at least 2 of the input words have differences, they are assumed to cancel out, while a single input word with difference never cancels out. Criteria for selecting suitable candidates then include a low number  $t$  of spanned steps and a low number of required cancellation constraints. The best (consistent) result for 39 steps, spanning  $t = 19$  steps with 9 cancellations, is given in Fig. 3d.

**Semi-free-start collisions and collisions.** The discussed starting points are targeted to find semi-free-start collisions, that is, different messages  $m, m'$  and an IV  $h_0$  such that  $f(h_0, m) = f(h_0, m')$ . However, they can also be used for hash function collisions with the original IV  $h_0$  by trading the freedom of the IV for freedom in the message words.

In order to find hash function collisions, the first few message words  $W_i$  must retain sufficient freedom (i.e., they should not be constrained by conditions from the message expansion for cancelling differences) to allow to match the correct IV value. Ideally, this means that the first 8 message words  $W_0, \dots, W_7$  are free of any conditions (no differences, but also not constrained by conditions from other message words connected via the message expansion). If the  $W_i$  differences are sparse enough overall, it can also be sufficient to have at least 5 words  $W_0, \dots, W_4$  free of conditions by providing the remaining freedom with a two-block approach [15].

The starting points of Fig. 3a and Fig. 3d both have at least 7 message words free of differences in the beginning. However, the local collision shown in Fig. 3d spans over  $t = 19$  steps. Thus, the first message words are constrained by many conditions, leaving not enough freedom to match the correct IV. The starting point with  $t = 18$  in Fig. 3c is similarly unsuitable for IV matching. In contrast, the 11-step local collision shown in Fig. 3a provides enough freedom in the first 7 message words to be used in a single-block collision attack [14].

## 4 Collision attacks for truncated SHA-512 variants

The hash functions SHA-512/224 and SHA-512/256 differ from SHA-512 in their IV and a final processing step, which truncates the 512-bit state to 224 or 256 bits, respectively. Consequently, the semi-free-start collisions demonstrated for SHA-512 [6] are also valid for these truncated versions (since the IV is non-standard anyway in this attack scenario). In this section, we first improve these results by providing 39-step semi-free-start collisions for SHA-512 and its variants. We then extend this result to free-start collisions for 43-step SHA-512/256 and 44-step SHA-512/224. By free-start collisions, we mean two messages  $m, m'$  and two IVs  $h_0, h'_0$  such that the hash values of  $m$  (under IV  $h_0$ ) and  $m'$  (under IV



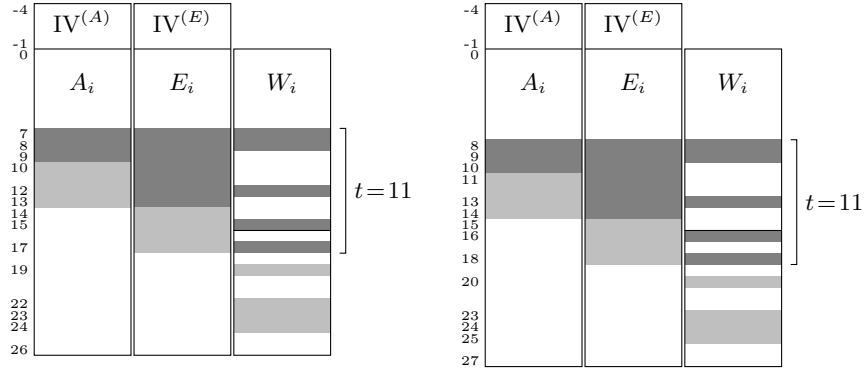

(a) 27-step collision of SHA-256 [14] and SHA-512 (Sect. 4.3).

(b) 28-step collision of SHA-256 [15] and SHA-224 (Sect. 4.3).

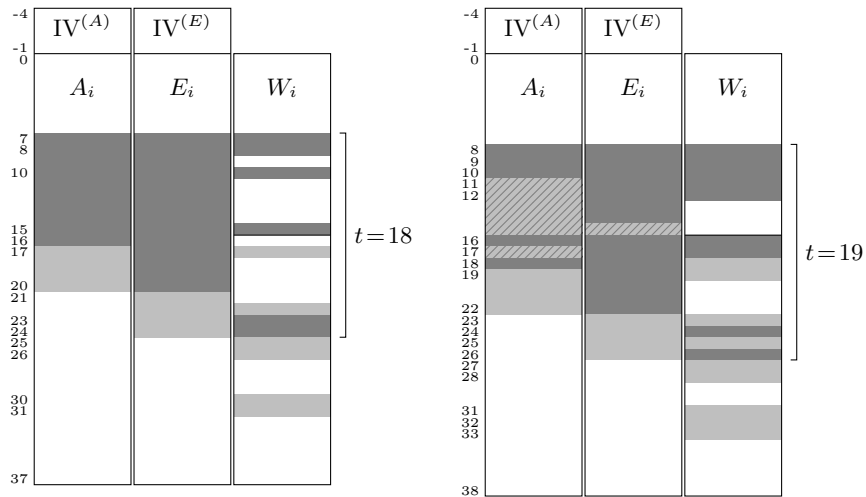

(c) 38-step semi-free-start collision of SHA-256 [15] and SHA-512 [6].

(d) 39-step semi-free-start collision of SHA-512 (Sect. 4.1).

**Fig. 3.** SHA-2 starting points: Words with differences ■ and cancellations ■, ▨.

$h'_0$ ) collide. Note that free-start collisions are not equivalent to collisions of the compression function for truncated SHA-2 versions, since the truncated output bits of the last compression function call may contain differences. Additionally, we present collisions for 27 steps of SHA-512, SHA-512/224, and SHA-512/256.

#### 4.1 Semi-free-start collisions

We use the 39-step starting point from Fig. 3d. Previous work showed that sparse differences particularly in the  $A_i$  words are essential for the success probability of the message modification phase. For this reason, we additionally require that in 6 words between  $A_8$  and  $A_{18}$ , namely  $A_{11}, A_{12}, A_{13}, A_{14}, A_{15}$ , and  $A_{17}$ , differences also cancel out. The five consecutive zero-difference words in  $A_i$  also force  $E_{15}$  to zero difference. These additional requirements are already marked in Fig. 3d (hatched area).

The first task for the search procedure with the solving tool is to fix a suitable signed characteristic. Compared to the previously published 38-step SHA-512 semi-free-start collision [6], the local collision for our starting point spans 19 steps (compared to previously 18) and has 9 (previously 6) active expanded message words. Cancellations are also required in 9 (previously 6) expanded message words. This increases the necessity for very sparse differences in  $A_i$  and  $W_i$  in steps 16–26. For this reason, we require a single-bit difference in  $W_{26}, W_{17}$  and  $A_{18}$ , and very low Hamming weights for the other words. We finally found a characteristic with at most two active bits in almost all words of  $A_i$  and  $W_i$  (except  $A_9, A_{10}, W_{11}, W_{12}$ ), given in Appendix C in Table 4.

After the characteristic is fixed, we need to find a complying message pair. We start by guessing the dense parts in  $A_i$  and  $E_i$ , hoping that the sparser conditions in the later steps are fulfilled probabilistically. Since the dense parts are already almost fully determined by the characteristics and the sparse parts pose only so few conditions, a message pair is easily found. The result is a semi-free-start collision valid for all SHA-512 variants. We give an example in Appendix D in Table 12a.

#### 4.2 Free-start collisions

Free-start collisions are a generalization of semi-free-start collisions, so the 39-step results obtained in the previous section give a first result for SHA-512/224 and SHA-512/256. However, we can take advantage of the truncated output bits to add several more steps. If we add another step in the beginning or in the end, the existing difference pattern remains unchanged, but there will be differences in the word  $W_0$  (computable via backward expansion, which includes  $W_{i+9} = W_9$ , the previous  $W_8$  from Fig. 3d) or in the new word  $W_{39}$  (via the normal forward expansion, which includes  $W_{39-15} = W_{24}$ ), respectively. These, in turn, can imply differences in  $E_{-4}$  or in  $A_{39}$  and  $E_{39}$ , which translates to differences in the IV (turning semi-free-start into free-start results, and included in the hash value via the feed-forward) or directly in the compression function output, respectively.

The advantage of adding steps in the beginning is that it is possible to limit the additional differences in the state update words to  $E$ , and keep  $A$  free of new differences. Any differences in  $E_{-1}, \dots, E_{-4}$  will be added to the compression function output with the final feed-forward, but the corresponding words of the result are truncated, so the hash outputs still collide.

**Free-start collisions for 43-step SHA-512/256.** Since SHA-512/256 truncates the last 4 output words of the compression function call ( $E_{79} + E_{-1}$ ,  $E_{78} + E_{-2}$ ,  $E_{77} + E_{-3}$ , and  $E_{76} + E_{-4}$ ), differences in  $E_{-1}, \dots, E_{-4}$  are acceptable for a free-start collision. This observation allows us to add 4 additional steps in the beginning of the 39-step starting point from Fig. 3d. Shifting the characteristic “downwards” by 4 steps causes the previous message words  $W_{12}, \dots, W_{15}$  to turn into new expanded message words  $W_{16}, \dots, W_{19}$ ; in particular, this affects the difference in the previous word  $W_{12}$ . To determine a compatible difference pattern for the new first 4 words, the message expansion can be computed backwards from the new words  $W_4, \dots, W_{19}$  via

$$W_i = W_{i+16} - \sigma_1(W_{i+14}) - W_{i+9} - \sigma_0(W_{i+1}).$$

It turns out that all 4 new words will contain differences ( $W_3$  from  $W_{3+9} = W_{12}$ ;  $W_2$  from  $W_{2+1} = W_3$  and  $W_{2+14} = W_{16}$ ;  $W_1$  from  $W_{1+1} = W_2$  and  $W_{1+14} = W_{15}$ ; and  $W_0$  from  $W_{0+1} = W_1$ ,  $W_{0+14} = W_{14}$  and  $W_{0+16} = W_{16}$ ). However, similar to steps 27–30, the state words  $A_i$  and  $E_i$  can be kept free of differences for 4 steps. To achieve this, the search tool needs to find differences in the IV words  $E_{-4}, \dots, E_{-1}$  to cancel out those in  $W_0, \dots, W_3$  when computing  $E_0, \dots, E_3$ . The resulting starting point is given in Fig. 4a.

For the search procedure with the solving tool, we fixed the signed differences of steps 12–30 to the same values as the 39-step SHA-512 semi-free-start collision of Sect. 4.1. Then, to complete the characteristic, we first search for a valid solution for the dense part of the middle steps ( $A_i$  and  $E_i$  in steps 13–16, and  $E_i$  in steps 17–27), and finally fix the corresponding message words  $W_i$  in steps 13–17, which determines the complete state, including the dense differences in the prepended steps and IV.

The search only takes seconds on a standard computer; an example for a free-start collision is given in Appendix D in Table 10a. We also give a free-start collision for 41-step SHA-384 obtained with the same method (with 2 instead of 4 additional steps) in Table 11a, as well as one for 39-step SHA-224 (with 1 additional step added to the 38-step SHA-256 characteristic [15]) in Table 13a.

**Free-start collisions for 44-step SHA-512/224.** A very similar strategy can be employed to extend the previous 43-step free-start collision by another step for SHA-512/224. Prepending an additional step shifts the difference of previous word  $E_{-1}$  to  $E_0$ , which in turn requires a cancellation in  $A_0$  and a difference in  $A_{-4}$ , as illustrated in Fig. 4b. However, only the least significant 32 bits of the corresponding compression function output word are truncated. Furthermore,

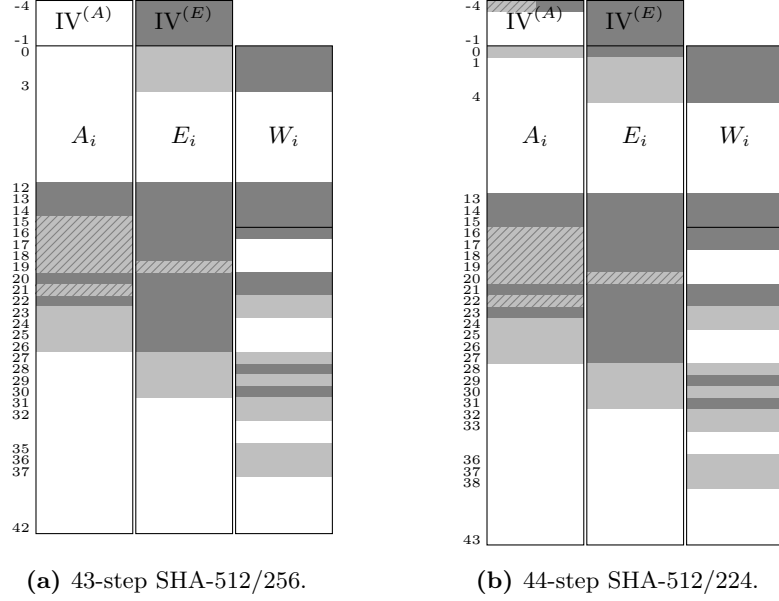

**Fig. 4.** Potential free-start starting points (differences ■ and cancellations ▨, ▩).

this output word is computed from  $A_{-4}$  via modular addition, so even differences only in the lower 32 bits can possibly cause differences in the untruncated output bits.

Fortunately, the underlying characteristic of signed differences as used for the 39-step SHA-512 semi-free-start collision is well compatible with our constraints: The difference in  $A_{-4}$  needs to cancel that in  $W_4$  in a modular addition (via  $E_0$ , by equations (3) and (2) or Fig. 2, since all other involved words have zero difference). This difference of  $W_4$ , in turn, is dictated by that in  $W_{13}$  (by the update rule for  $W_{20}$ , where again all other involved words have zero difference). None of these equalities involves any of the bitwise functions  $\sigma$ ,  $\Sigma$ , MAJ or IF. Thus, the modular difference in  $A_{-4}$  must be the same as that in  $W_{13}$ , which is already fixed by the underlying characteristic to a modular difference of  $+32$ . Written as bitwise differences, this will translate to a single-bit difference (in the sixth least significant bit) with probability  $\frac{1}{2}$  (which does not carry over to the untruncated bits of the final output with overwhelming probability). Indeed, the example for a free-start collision given in Appendix D in Table 9a only displays this single-bit difference in  $A_{-4}$  (and no carries in the output bits).

### 4.3 Collisions

So far, the best practical collisions found for SHA-512 are those for 24 steps, proposed independently by Sanadhya and Sarkar [19] and Indestege et al. [8], together with 24-step collisions for SHA-256. While the results for SHA-256 have

since been improved to 27 [14], 28 [15] (both practical), and finally 31 steps [15] (theoretical attack with almost practical complexity), no such improvements have been proposed for SHA-512 so far. The main reason for this seems to be the doubling in state size from SHA-256 to SHA-512; this larger search space increases the difficulty of the problem for the search tools.

**Starting point for SHA-512.** Since the message expansion is essentially the same for all SHA-2 variants (except for different word sizes and rotation values, of course), the SHA-256 starting points can theoretically also be used for SHA-512. However, the resulting search complexity is different. For our results, we used the 27-step starting point (based on a local collision over the  $t = 11$  steps 7–17), as illustrated in Fig. 3a. Just as the 39-step semi-free-start starting point (Fig. 3d), it requires that differences cancel in  $E$  in 4 of the  $t$  steps ( $E_{14}, \dots, E_{17}$ ) and in  $A$  in the 4 previous steps ( $A_{10}, \dots, A_{13}$ ), as well as in several steps of the message expansion.

Finding a solution from this starting point requires significantly more effort than for SHA-256. Of course, we also tried to expand our search to the closely related 28-step starting point, which adds an additional step in the beginning of the 27-step version. However, with the additional constraints imposed on the message expansion by this added step we could not find any suitable (reasonably sparse) characteristics.

In contrast to the results from Sect. 4.2, since the IV needs to exactly match the original IV, we were not able to take advantage of the final truncation to simplify the search process, or add additional steps. We first search a characteristic for SHA-512, and then try to use it to match the different IVs for SHA-512/224, SHA-512/256, SHA-384, and SHA-512.

**Search strategy.** The search progresses in several stages, as illustrated in Fig. 5:

1. **Fix signed characteristic:**

- (a) **Find candidate characteristic** (Fig. 5a): First fix the signed differences of the message expansion  $W$  (5 words) and state update  $A$  (3 words). Since the word  $W_{17}$  poses conditions on the first few message words, whose freedom we will later need to match the IV, we focus on keeping its signed difference as sparse as possible, with only few difference bits. With much lower priority, also determine the differences in the state update words  $E$  (7 words) to complete the signed characteristic. The characteristic is very dense in  $E$ , but this only has limited influence on the success of the IV matching phase.
- (b) **Verify dense parts** (Fig. 5b): Fully determine the values of  $A$  and  $E$  in the densest steps 7–9 to verify the validity of the candidate characteristic. If necessary, fix any remaining free bits of  $A$  and  $E$  in steps 10–11. This fully determines  $A_3, \dots, A_{11}$ ,  $E_7, \dots, E_{11}$  and  $W_{11}$ .

To maneuver the search process in the large search space and detect contradictions as soon as possible, we need to apply the look-ahead strategies

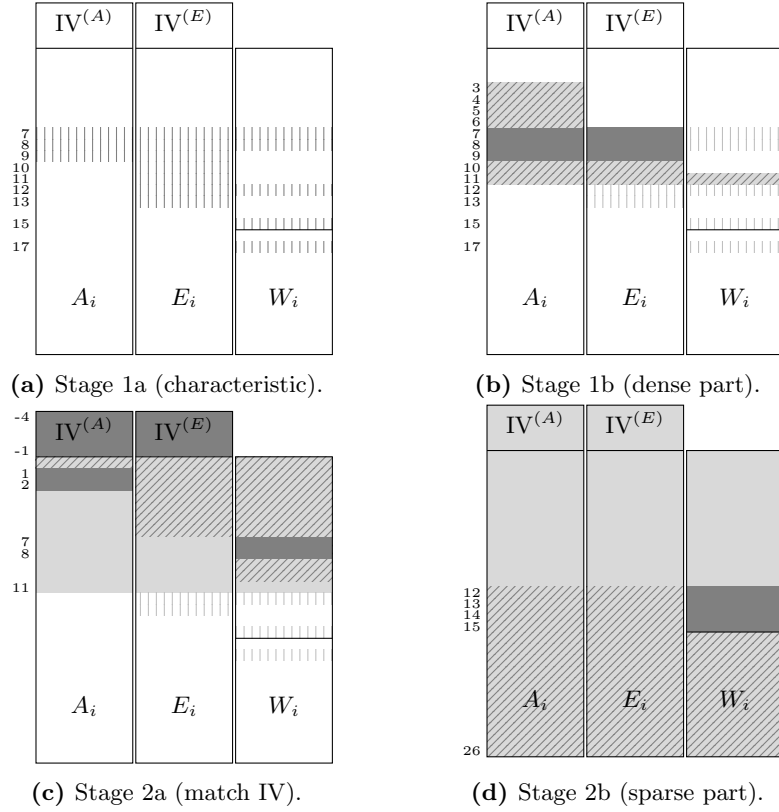

**Fig. 5.** Stages of the 27-step collision search (guessed values  $\blacksquare$  and differences  $\square$ , derived values  $\text{\textbackslash}\text{\textbackslash}$ , and previously fixed values  $\text{\textbackslash}\text{\textbackslash}$  and differences  $\square$ ).

previously employed for semi-free-start collisions on SHA-512 [6] in this stage (with 16 look-ahead candidates per guess).

2. **Message modification to match IV**: Starting from the best signed characteristics of the previous stage, with the correct IV inserted, find a solution message pair step by step:

- (a) **Match IV** (Fig. 5c): Fix the values in the more difficult, heavily constrained words first ( $W_{10}, W_9, W_8, W_7$ ). Choosing  $W_{10}$  and  $W_9$  also determines  $A_2$  and  $A_1$  (via  $E_6$  and  $E_5$ ). Together with  $W_7, W_8$ , and the IV, this determines all values in steps 0–11.
- (b) **Finalize message for sparse parts** (Fig. 5d): choosing the 4 remaining message words  $W_{12}, \dots, W_{15}$  allows to satisfy the remaining, sparse parts of the characteristic in steps 12–26 with high probability.

Unlike the other stages, guesses are not made randomly here, but systematically word-by-word. Since most conditions are from modular additions, we always start from the least significant bits and proceed towards the more

significant bits. This last stage needs to be repeated for each IV separately, which takes some hours on a single CPU per target IV.

**Results.** Our results for collisions for 27-step SHA-512/224, SHA-512/256, SHA-384, and SHA-512 are given in Appendix D in Tables 9b, 10b, 11b, and 12b, respectively. We also include a 28-step collision for SHA-224, based on the SHA-256 characteristic [15], in Table 13b.

**Acknowledgments.** This research (or a part of this research) is supported by Cryptography Research and Evaluation Committee (CRYPTREC) and by the Austrian Research Promotion Agency (FFG) and the Styrian Business Promotion Agency (SFG) under grant number 836628 (SeCoS).

## References

1. Aoki, K., Guo, J., Matusiewicz, K., Sasaki, Y., Wang, L.: Preimages for step-reduced SHA-2. In: Matsui, M. (ed.) *Advances in Cryptology – ASIACRYPT 2009*. LNCS, vol. 5912, pp. 578–597. Springer (2009)
2. Biryukov, A., Lamberger, M., Mendel, F., Nikolic, I.: Second-order differential collisions for reduced SHA-256. In: Lee, D.H., Wang, X. (eds.) *Advances in Cryptology – ASIACRYPT 2011*. LNCS, vol. 7073, pp. 270–287. Springer (2011)
3. Coron, J., Dodis, Y., Malinaud, C., Puniya, P.: Merkle-Damgård revisited: How to construct a hash function. In: Shoup, V. (ed.) *Advances in Cryptology – CRYPTO 2005*. LNCS, vol. 3621, pp. 430–448. Springer (2005)
4. Damgård, I.: A design principle for hash functions. In: Brassard, G. (ed.) *Advances in Cryptology – CRYPTO ’89*. LNCS, vol. 435, pp. 416–427. Springer (1989)
5. De Cannière, C., Rechberger, C.: Finding SHA-1 characteristics: General results and applications. In: Lai, X., Chen, K. (eds.) *Advances in Cryptology – ASIACRYPT 2006*. LNCS, vol. 4284, pp. 1–20. Springer (2006)
6. Eichlseder, M., Mendel, F., Schläffer, M.: Branching heuristics in differential collision search with applications to SHA-512. In: Cid, C., Rechberger, C. (eds.) *Fast Software Encryption – FSE 2014*. LNCS, vol. 8540, pp. 473–488. Springer (2014)
7. Gueron, S., Johnson, S., Walker, J.: SHA-512/256. In: Latifi, S. (ed.) *Information Technology: New Generations – ITNG 2011*. pp. 354–358. IEEE Computer Society (2011)
8. Indestege, S., Mendel, F., Preneel, B., Rechberger, C.: Collisions and other non-random properties for step-reduced SHA-256. In: Avanzi, R.M., Keliher, L., Sica, F. (eds.) *Selected Areas in Cryptography – SAC 2008*. LNCS, vol. 5381, pp. 276–293. Springer (2009)
9. Joux, A.: Multicollisions in iterated hash functions. Application to cascaded constructions. In: Franklin, M.K. (ed.) *Advances in Cryptology – CRYPTO 2004*. LNCS, vol. 3152, pp. 306–316. Springer (2004)
10. Kelsey, J., Kohno, T.: Herding hash functions and the Nostradamus attack. In: Vaudenay, S. (ed.) *Advances in Cryptology – EUROCRYPT 2006*. LNCS, vol. 4004, pp. 183–200. Springer (2006)
11. Kelsey, J., Schneier, B.: Second preimages on  $n$ -bit hash functions for much less than  $2^n$  work. In: Cramer, R. (ed.) *Advances in Cryptology – EUROCRYPT 2005*. LNCS, vol. 3494, pp. 474–490. Springer (2005)

12. Khovratovich, D., Rechberger, C., Savelieva, A.: Bicliques for preimages: Attacks on Skein-512 and the SHA-2 family. In: Canteaut, A. (ed.) *Fast Software Encryption – FSE 2012*. LNCS, vol. 7549, pp. 244–263. Springer (2012)
13. Li, J., Isobe, T., Shibutani, K.: Converting meet-in-the-middle preimage attack into pseudo collision attack: Application to SHA-2. In: Canteaut, A. (ed.) *Fast Software Encryption – FSE 2012*. LNCS, vol. 7549, pp. 264–286. Springer (2012)
14. Mendel, F., Nad, T., Schl affer, M.: Finding SHA-2 characteristics: Searching through a minefield of contradictions. In: Lee, D.H., Wang, X. (eds.) *Advances in Cryptology – ASIACRYPT 2011*. LNCS, vol. 7073, pp. 288–307. Springer (2011)
15. Mendel, F., Nad, T., Schl affer, M.: Improving local collisions: New attacks on reduced SHA-256. In: Johansson, T., Nguyen, P.Q. (eds.) *Advances in Cryptology – EUROCRYPT 2013*. LNCS, vol. 7881, pp. 262–278. Springer (2013)
16. Merkle, R.C.: One way hash functions and DES. In: Brassard, G. (ed.) *Advances in Cryptology – CRYPTO ’89*. LNCS, vol. 435, pp. 428–446. Springer (1989)
17. National Institute of Standards and Technology: FIPS PUB 180-4: Secure Hash Standard. Federal Information Processing Standards Publication 180-4, U.S. Department of Commerce (March 2012), <http://csrc.nist.gov/publications/fips/fips180-4/fips-180-4.pdf>
18. Nikolic, I., Biryukov, A.: Collisions for step-reduced SHA-256. In: Nyberg, K. (ed.) *Fast Software Encryption – FSE 2008*. LNCS, vol. 5086, pp. 1–15. Springer (2008)
19. Sanadhya, S.K., Sarkar, P.: New collision attacks against up to 24-step SHA-2. In: Chowdhury, D.R., Rijmen, V., Das, A. (eds.) *Progress in Cryptology – INDOCRYPT 2008*. LNCS, vol. 5365, pp. 91–103. Springer (2008)
20. Wang, X., Yin, Y.L., Yu, H.: Finding collisions in the full SHA-1. In: Shoup, V. (ed.) *Advances in Cryptology – CRYPTO 2005*. LNCS, vol. 3621, pp. 17–36. Springer (2005)
21. Wang, X., Yu, H.: How to break MD5 and other hash functions. In: Cramer, R. (ed.) *Advances in Cryptology – EUROCRYPT 2005*. LNCS, vol. 3494, pp. 19–35. Springer (2005)
22. Yu, H., Bai, D.: Boomerang attack on step-reduced SHA-512. IACR Cryptology ePrint Archive, Report 2014/945 (2014), <http://ia.cr/2014/945>

## A Search Algorithm

The search algorithm builds on previous published work on SHA-2 collision attacks. We use essentially the same search algorithm as Eichlseder et al. [6]. For reference, we quote the high-level pseudo code for the guess-and-determine search algorithm (Algorithm 1) and for the look-ahead heuristic (Algorithm 2) given in [6], and discuss some details specific to this paper in the following.

**Starting point.** Before starting the algorithm, the characteristic is initialized with a few constraints as a starting point. The exact starting points for this paper as motivated in Sect. 3.2, 4.1, 4.2, and 4.3 are specified in the tables of Appendix C.



---

**Algorithm 1** Guess-and-Determine Search Algorithm

---

Let  $U$  be a set of undetermined bits

**while**  $U$  contains undetermined bits **do**

**Decision (Guessing)**

1. Pick an undetermined bit (randomly or heuristically)
2. Impose new constraints on this bit

**Deduction (Propagation)**

3. propagate the new information to other variables and equations
4. **if** an inconsistency is detected, start backtracking,  
    **else** continue with step 1

**Backtracking (Correction)**

5. Try a different choice for the decision bit and continue with step 3.
  6. **if** all choices result in inconsistencies,  
    undo guesses until this critical bit can be resolved
- 

---

**Algorithm 2** Look-ahead branching heuristic for differential cryptanalysis

---

Let  $U$  be a set of undetermined bits and  $s_{\max}$  the limit of look-ahead candidates.

**repeat**

**Guessing**

1. Pick a bit  $v \in U$  randomly and increment  $s$
2. Impose new constraints on this bit  $v$

**Propagation**

3. Propagate the new information to other variables and equations
4. **if** an inconsistency is detected, **return**  $v$  as the decision bit  
    **else** count the number  $m$  of additional variables that were assigned due to  
    this guess and save the pair  $(v, m)$  in a list  $L$ .

**Update**

5. Remove all variables that were assigned due to the guess  $v$  from the set  $U$
6. Undo all changes to restore the original assignment

**until**  $U$  is empty or  $s \geq s_{\max}$

**return**  $v^*$  from  $L$  with the highest score  $m$  as the decision bit

---

**Guessing.** The sets  $U$  are defined by the settings of each phase as specified in the search strategy in Appendix B. For picking the next bit of  $U$  in step 1, we first randomly select one of the settings (see Appendix B), and then either select the next least significant bit (if the setting specifies ordered guesses), or apply Algorithm 2 for look-ahead (in Phase I only), or pick a random bit in  $U$  (otherwise). The new constraints for the selected decision bit are also assigned probabilistically, as specified by the setting.

We apply Algorithm 2 only in Phase I, with  $s_{\max} = 16$ . For the **Guessing** and **Propagation** steps in Algorithm 2, we use the same settings that are currently active in the main search in Algorithm 1.

**Propagation.** We propagate information by bit-sliced propagation [5].

**Backtracking.** If all alternatives for the current decision bit fail, we undo the guess and continue with alternatives for the previous guess, etc. If the previous guess was not “stacked” (specified by the setting, see Appendix B), we just undo the guess, skip its alternatives, and continue with the guess before. After reaching a certain threshold (e.g., 10 000) of such contradictions in a search tree, we restart the complete algorithm (i.e., restart from the starting point, without remembering any information from the aborted search).

**Additional checks.** In addition, we collect and optionally (after a phase ends) check multi-bit information (2-bit conditions  $\boxminus$ ), as applied previously to SHA-2 by Mendel et al. [14].

## B Search Strategy and Configuration

Below, we list all search parameters defining the respective search strategy. Each strategy is listed as an enumeration of several phases, and the algorithm only switches to the next phase when all bits of the current phase have been fixed (according to the defined settings). In each step, the algorithm selects one of the settings of the current phase randomly, distributed according to their specified weights  $w$  (e.g., a weight-5 setting is selected with 5 times the probability of a weight-1 setting). Each setting specifies which constraints of which words can be selected for guessing, and according to which guess pattern they are refined. In addition, it specifies whether (with which probability  $p$ ) the choice is stored in the search tree for backtracking (i.e., on conflicts during backtracking, the opposite/alternative guess will be considered; otherwise, backtracking skips the alternative and proceeds resolving with the previous stored guess).

The notation for the bit constraints in guess settings and characteristics follows the conventions of other SHA-2 analysis papers and is summarized in Table 2, together with our common guessing strategy and stacking probability.

**Table 2.** Notation for SHA-2 bit conditions [5,14] and our guessing/stacking strategy.

Cond.	Possible bit pairs	Description	Guessed to	Stack
?	Any	No constraints	- (100 %)	$p = 0$
$\boxminus$	(0, 0), (1, 1)	Equal ( $\boxminus$ 2-bit cond.)	0 (50 %), 1 (50 %)	$p = 1$
0	(0, 0)	Fixed, equal bits		
1	(1, 1)	Fixed, equal bits		
$\mathbf{x}$	(0, 1), (1, 0)	Different bits	$\left\{ \begin{array}{l} \text{biased } \mathbf{u} (20 \%), \mathbf{n} (80 \%) \\ \text{or fair } \mathbf{u} (50 \%), \mathbf{n} (50 \%) \end{array} \right.$	$p = 1$
$\mathbf{u}$	(1, 0)	Fixed, different bits		
$\mathbf{n}$	(0, 1)	Fixed, different bits		

**SHA-512/ $t$  39-step semi-free-start collision (Sect. 4.1).**

- **Phase I:** Guess  $?$ ,  $\mathbf{x}$  in  $\mathbf{W}$  ( $w = 5$ ) or  $\mathbf{E}, \mathbf{A}$  ( $w = 1$ ) (with final 2-bit-condition check; using look-ahead with  $s_{\max} = 16$ ; biased guesses for  $\mathbf{x}$ )
- **Phase II:** Guess - in  $\mathbf{A}_{9\dots 12}, \mathbf{E}_{9\dots 12}$  (ordered guesses from LSB to MSB)
- **Phase III:** Guess - in  $\mathbf{E}_{13\dots 24}$  (ordered guesses from LSB to MSB)
- **Phase IV:** Guess - in  $\mathbf{W}_{9\dots 12}$  (ordered guesses from LSB to MSB)

**SHA-512/256 43-step free-start collision (Sect. 4.2).** The strategy is essentially the same as for the 39-step semi-free-start collision; the output of Phase I there can be directly reused here.

- **Phase I:** Characteristic  $(-, \mathbf{x}, \mathbf{n}, \mathbf{u})$  copied from 39-step result (shift 4 steps)
- **Phase II:** Guess - in  $\mathbf{A}_{13\dots 16}, \mathbf{E}_{13\dots 16}$  (ordered guesses from LSB to MSB)
- **Phase III:** Guess - in  $\mathbf{E}_{17\dots 27}$  (ordered guesses from LSB to MSB)
- **Phase IV:** Guess - in  $\mathbf{W}_{13\dots 16}$  (ordered guesses from LSB to MSB)

**SHA-512/224 44-step free-start collision (Sect. 4.2).**

- **Phase I:** Characteristic  $(-, \mathbf{x}, \mathbf{n}, \mathbf{u})$  copied from 39-step result (shift 5 steps)
- **Phase II:** Guess - in  $\mathbf{A}_{14\dots 17}, \mathbf{E}_{14\dots 17}$  (ordered guesses from LSB to MSB)
- **Phase III:** Guess - in  $\mathbf{E}_{18\dots 28}$  (ordered guesses from LSB to MSB)
- **Phase IV:** Guess - in  $\mathbf{W}_{14\dots 17}$  (ordered guesses from LSB to MSB)

**SHA-512/ $t$  27-step collision (Sect. 4.3).**

- **Phase I, Step 1(a):** Guess  $?$ ,  $\mathbf{x}$  in  $\mathbf{W}_{17}$  ( $w = 20$ ) or  $\mathbf{A}, \mathbf{W}$  ( $w = 5$ ) or  $\mathbf{A}, \mathbf{E}, \mathbf{W}$  ( $w = 1$ ) (with final 2-bit-condition check; look-ahead:  $s_{\max} = 16$ ; fair guesses for  $\mathbf{x}$ )
- **Phase II, Step 1(b):** Guess - in  $\mathbf{A}_{7\dots 9}, \mathbf{E}_{7\dots 9}$  (ordered guesses LSB to MSB)
- **Phase IIIa, Step 2(a):** Guess - in  $\mathbf{A}_2$  (ordered guesses from LSB to MSB)
- **Phase IIIb, Step 2(a):** Guess - in  $\mathbf{A}_1$  (ordered guesses from LSB to MSB)
- **Phase IIIc, Step 2(a):** Guess - in  $\mathbf{W}_8$  (ordered guesses from LSB to MSB)
- **Phase IIIId, Step 2(a):** Guess - in  $\mathbf{W}_7$  (ordered guesses from LSB to MSB)
- **Phase IV, Step 2(b):** Guess - in  $\mathbf{W}_{12\dots 15}$  (ordered guesses LSB to MSB)

## C Starting Points and Constraints

We list the starting points (initial constraints) and characteristics for the semi-free-start and free-start collisions of Sect. 4.1, 4.2 and the collisions of Sect. 4.3 in Tables 3–8.

## D Examples

Results for the free-start collisions of Sect. 4.2 are given in Tables 9a, 10a, 11a, 12a, and 13a, and for the collisions of Sect. 4.3 in Tables 9b, 10b, 11b, 12b, and 13b.

Table 3. Starting point for semi-free-start collision of 39 steps of SHA-512 and SHA-512/t.

	A	E	W
4	.....	.....	.....
3	.....	.....	.....
2	.....	.....	.....
1	.....	.....	.....
0	.....	.....	.....
38	.....	.....	.....
37	.....	.....	.....
36	.....	.....	.....
35	.....	.....	.....
34	.....	.....	.....
33	.....	.....	.....
32	.....	.....	.....
31	.....	.....	.....
30	.....	.....	.....
29	.....	.....	.....
28	.....	.....	.....
27	.....	.....	.....
26	.....	.....	.....
25	.....	.....	.....
24	.....	.....	.....
23	.....	.....	.....
22	.....	.....	.....
21	.....	.....	.....
20	.....	.....	.....
19	.....	.....	.....
18	.....	.....	.....
17	.....	.....	.....
16	.....	.....	.....
15	.....	.....	.....
14	.....	.....	.....
13	.....	.....	.....
12	.....	.....	.....
11	.....	.....	.....
10	.....	.....	.....
9	.....	.....	.....
8	.....	.....	.....
7	.....	.....	.....
6	.....	.....	.....
5	.....	.....	.....
4	.....	.....	.....
3	.....	.....	.....
2	.....	.....	.....
1	.....	.....	.....
0	.....	.....	.....
38	.....	.....	.....
37	.....	.....	.....
36	.....	.....	.....
35	.....	.....	.....
34	.....	.....	.....
33	.....	.....	.....
32	.....	.....	.....
31	.....	.....	.....
30	.....	.....	.....
29	.....	.....	.....
28	.....	.....	.....
27	.....	.....	.....
26	.....	.....	.....
25	.....	.....	.....
24	.....	.....	.....
23	.....	.....	.....
22	.....	.....	.....
21	.....	.....	.....
20	.....	.....	.....
19	.....	.....	.....
18	.....	.....	.....
17	.....	.....	.....
16	.....	.....	.....
15	.....	.....	.....
14	.....	.....	.....
13	.....	.....	.....
12	.....	.....	.....
11	.....	.....	.....
10	.....	.....	.....
9	.....	.....	.....
8	.....	.....	.....
7	.....	.....	.....
6	.....	.....	.....
5	.....	.....	.....
4	.....	.....	.....
3	.....	.....	.....
2	.....	.....	.....
1	.....	.....	.....
0	.....	.....	.....
38	.....	.....	.....
37	.....	.....	.....
36	.....	.....	.....
35	.....	.....	.....
34	.....	.....	.....
33	.....	.....	.....
32	.....	.....	.....
31	.....	.....	.....
30	.....	.....	.....
29	.....	.....	.....
28	.....	.....	.....
27	.....	.....	.....
26	.....	.....	.....
25	.....	.....	.....
24	.....	.....	.....
23	.....	.....	.....
22	.....	.....	.....
21	.....	.....	.....
20	.....	.....	.....
19	.....	.....	.....
18	.....	.....	.....
17	.....	.....	.....
16	.....	.....	.....
15	.....	.....	.....
14	.....	.....	.....
13	.....	.....	.....
12	.....	.....	.....
11	.....	.....	.....
10	.....	.....	.....
9	.....	.....	.....
8	.....	.....	.....
7	.....	.....	.....
6	.....	.....	.....
5	.....	.....	.....
4	.....	.....	.....
3	.....	.....	.....
2	.....	.....	.....
1	.....	.....	.....
0	.....	.....	.....
38	.....	.....	.....
37	.....	.....	.....
36	.....	.....	.....
35	.....	.....	.....
34	.....	.....	.....
33	.....	.....	.....
32	.....	.....	.....
31	.....	.....	.....
30	.....	.....	.....
29	.....	.....	.....
28	.....	.....	.....
27	.....	.....	.....
26	.....	.....	.....
25	.....	.....	.....
24	.....	.....	.....
23	.....	.....	.....
22	.....	.....	.....
21	.....	.....	.....
20	.....	.....	.....
19	.....	.....	.....
18	.....	.....	.....
17	.....	.....	.....
16	.....	.....	.....
15	.....	.....	.....
14	.....	.....	.....
13	.....	.....	.....
12	.....	.....	.....
11	.....	.....	.....
10	.....	.....	.....
9	.....	.....	.....
8	.....	.....	.....
7	.....	.....	.....
6	.....	.....	.....
5	.....	.....	.....
4	.....	.....	.....
3	.....	.....	.....
2	.....	.....	.....
1	.....	.....	.....
0	.....	.....	.....
38	.....	.....	.....
37	.....	.....	.....
36	.....	.....	.....
35	.....	.....	.....
34	.....	.....	.....
33	.....	.....	.....
32	.....	.....	.....
31	.....	.....	.....
30	.....	.....	.....
29	.....	.....	.....
28	.....	.....	.....
27	.....	.....	.....
26	.....	.....	.....
25	.....	.....	.....
24	.....	.....	.....
23	.....	.....	.....
22	.....	.....	.....
21	.....	.....	.....
20	.....	.....	.....
19	.....	.....	.....
18	.....	.....	.....
17	.....	.....	.....
16	.....	.....	.....
15	.....	.....	.....
14	.....	.....	.....
13	.....	.....	.....
12	.....	.....	.....
11	.....	.....	.....
10	.....	.....	.....
9	.....	.....	.....
8	.....	.....	.....
7	.....	.....	.....
6	.....	.....	.....
5	.....	.....	.....
4	.....	.....	.....
3	.....	.....	.....
2	.....	.....	.....
1	.....	.....	.....
0	.....	.....	.....
38	.....	.....	.....
37	.....	.....	.....
36	.....	.....	.....
35	.....	.....	.....
34	.....	.....	.....
33	.....	.....	.....
32	.....	.....	.....
31	.....	.....	.....
30	.....	.....	.....
29	.....	.....	.....
28	.....	.....	.....
27	.....	.....	.....
26	.....	.....	.....
25	.....	.....	.....
24	.....	.....	.....
23	.....	.....	.....
22	.....	.....	.....
21	.....	.....	.....
20	.....	.....	.....
19	.....	.....	.....
18	.....	.....	.....
17	.....	.....	.....
16	.....	.....	.....
15	.....	.....	.....
14	.....	.....	.....
13	.....	.....	.....
12	.....	.....	.....
11	.....	.....	.....
10	.....	.....	.....
9	.....	.....	.....
8	.....	.....	.....
7	.....	.....	.....
6	.....	.....	.....
5	.....	.....	.....
4	.....	.....	.....
3	.....	.....	.....
2	.....	.....	.....
1	.....	.....	.....
0	.....	.....	.....

Table 4. Characteristic for semi-free-start collision of 39 steps of SHA-512 and SHA-512/t.

$i$	A	E	W
-4			
-3			
-2			
-1			
0			
1			
2			
3			
4			
5			
6			
7			
8			
9			
10			
11			
12			
13			
14			
15			
16			
17			
18			
19			
20			
21			
22			
23			
24			
25			
26			
27			
28			
29			
30			
31			
32			
33			
34			
35			
36			
37			
38			

Table 5. Characteristic for free-start collision of 43 steps of SHA-512/256.

	A	E	W
1	.....	.....	.....
2	.....	.....	.....
3	.....	.....	.....
4	.....	.....	.....
5	.....	.....	.....
6	.....	.....	.....
7	.....	.....	.....
8	.....	.....	.....
9	.....	.....	.....
10	.....	.....	.....
11	.....	.....	.....
12	.....	.....	.....
13	.....	.....	.....
14	.....	.....	.....
15	.....	.....	.....
16	.....	.....	.....
17	.....	.....	.....
18	.....	.....	.....
19	.....	.....	.....
20	.....	.....	.....
21	.....	.....	.....
22	.....	.....	.....
23	.....	.....	.....
24	.....	.....	.....
25	.....	.....	.....
26	.....	.....	.....
27	.....	.....	.....
28	.....	.....	.....
29	.....	.....	.....
30	.....	.....	.....
31	.....	.....	.....
32	.....	.....	.....
33	.....	.....	.....
34	.....	.....	.....
35	.....	.....	.....
36	.....	.....	.....
37	.....	.....	.....
38	.....	.....	.....
39	.....	.....	.....
40	.....	.....	.....
41	.....	.....	.....
42	.....	.....	.....

Table 6. Characteristic for free-start collision of 44 steps of SHA-512/224.

$i$	A	E	W
1	.....	.....	.....
2	.....	.....	.....
3	.....	.....	.....
4	.....	.....	.....
5	.....	.....	.....
6	.....	.....	.....
7	.....	.....	.....
8	.....	.....	.....
9	.....	.....	.....
10	.....	.....	.....
11	.....	.....	.....
12	.....	.....	.....
13	.....	.....	.....
14	.....	.....	.....
15	.....	.....	.....
16	.....	.....	.....
17	.....	.....	.....
18	.....	.....	.....
19	.....	.....	.....
20	.....	.....	.....
21	.....	.....	.....
22	.....	.....	.....
23	.....	.....	.....
24	.....	.....	.....
25	.....	.....	.....
26	.....	.....	.....
27	.....	.....	.....
28	.....	.....	.....
29	.....	.....	.....
30	.....	.....	.....
31	.....	.....	.....
32	.....	.....	.....
33	.....	.....	.....
34	.....	.....	.....
35	.....	.....	.....
36	.....	.....	.....
37	.....	.....	.....
38	.....	.....	.....
39	.....	.....	.....
40	.....	.....	.....
41	.....	.....	.....
42	.....	.....	.....
43	.....	.....	.....
44	.....	.....	.....

Table 7. Starting point for collision of 27 steps of SHA-512 and SHA-512/*t*.

	A	E	W
4	.....	.....	.....
3	.....	.....	.....
2	.....	.....	.....
1	.....	.....	.....
0	.....	.....	.....
0	.....	.....	.....
1	.....	.....	.....
2	.....	.....	.....
3	.....	.....	.....
4	.....	.....	.....
5	.....	.....	.....
6	.....	.....	.....
7	.....	.....	.....
8	.....	.....	.....
9	.....	.....	.....
10	.....	.....	.....
11	.....	.....	.....
12	.....	.....	.....
13	.....	.....	.....
14	.....	.....	.....
15	.....	.....	.....
16	.....	.....	.....
17	.....	.....	.....
18	.....	.....	.....
19	.....	.....	.....
20	.....	.....	.....
21	.....	.....	.....
22	.....	.....	.....
23	.....	.....	.....
24	.....	.....	.....
25	.....	.....	.....
26	.....	.....	.....



Table 8. Characteristic for collision of 27 steps of SHA-512 and SHA-512/t.

$k$	A	E	W
-4			
-3			
-2			
-1			
0			
1			
2			
3			
4			
5			
6			
7			
8			
9			
10			
11			
12			
13			
14			
15			
16			
17			
18			
19			
20			
21			
22			
23			
24			
25			
26			

**Table 9.** Results for SHA-512/224.

(a) Example of a free-start collision for 44 steps of SHA-512/224.

$h_0$	fef65b64d3694995 959fbfb82ed84eb1 1d9e855642e62ef2 335cc6d027695d91 921d197e5cfa2803 e26c6eb26163a692 9ff3cf4d26f1de78 5323942861d9139a
$h_0^*$	fef65b64d3694995 959fbfb82ed84eb1 1d9e855642e62ef2 335cc6d027695db1 a712860cdcfa1ff8 470749bbf7628f44 20cdfd694df67216 8e07b5fa2c7fedf0
$\Delta h_0$	0000000000000000 0000000000000000 0000000000000000 0000000000000020 350f9f72800037fb a56b2709960129d6 bf3e32246b07ac6e dd2421d24da6fe6a
$m$	7a19df6089d00684 03ed2a0d0c29e00e 36c91e35f681fbb8 bb2b47428aef294 dce94ccc981d39a3 44230f73cf56d9ef e9d46b26b44950c8 550bed4b9419741c 58a98894206e00de f3448a6f761d384d 9ae59f3a3bcc5bba ece85d5c77be431b 6e3cf817e9376cc7 b74a2a43c0b96c93 7c5b51d6fe2a0c26 5a9868e5bf2e422d
$m^*$	5e031bbe28b2d027 ded424ef85255cc3 ad2f514be0830c1f a635dab40aeffa9f dce94ccc981d3983 44230f73cf56d9ef e9d46b26b44950c8 550bed4b9419741c 58a98894206e00de f3448a6f761d384d 9ae59f3a3bcc5bba ece85d5c77be431b 6e3cf817e9376cc7 b74a2a43c0b96cb3 5c5b51d6fe2a0c36 5a9868e5bf2e420d
$\Delta m$	241ac4dea162d6a3 dd390ee2890cbccd 9be64f7e1602f7a7 1d1e9df68000080b 0000000000000020 0000000000000000 0000000000000000 0000000000000000 0000000000000000 0000000000000000 0000000000000000 0000000000000000 0000000000000000 0000000000000020 2000000000000010 0000000000000020
$h_1$	e309edf68f4d89b8 5c356e0359eb0dab 76b4a45ec3c2cd25 8bd0955d

(b) Example of a collision for 27 steps of SHA-512/224.

$m$	20dbf13a352116a9 295506e205afd435 abfe4826742c1a1a 279f07c7813dd9be 47da77c701a98858 25aec1349d486501 37a992a15616ea31 e2b122ecf19e90d3 2fff6025dc03dd67 032c261d740f459e 2e2599bd6e7e74df d490bd22815eb494 72fedf1f607df6e3 87fc91fcfb7397fd e647b1b499eee17f 2dff8e493cbc8a4c
$m^*$	20dbf13a352116a9 295506e205afd435 abfe4826742c1a1a 279f07c7813dd9be 47da77c701a98858 25aec1349d486501 37a992a15616ea31 5cc1250cb19e90d3 203fdfe5dc03dd66 032c261d740f459e 2e2599bd6e7e74df d490bd22815eb494 f0bc01167075f6eb 87fc91fcfb7397fd e647b1b499eee17f d3f8fe713d7c8a4c
$\Delta m$	0000000000000000 0000000000000000 0000000000000000 0000000000000000 0000000000000000 0000000000000000 0000000000000000 be7007e040000000 0fc0bfc000000001 0000000000000000 0000000000000000 0000000000000000 8242de0910080008 0000000000000000 0000000000000000 fe07703801c00000
$h_1$	65b11e66e48da563 1b70d12da92e2dba 8f338768bb95601b 60b9955b

**Table 10.** Results for SHA-512/256.

(a) Example of a free-start collision for 43 steps of SHA-512/256.

$h_0$	159b52516f10f30d 546b2042f240afee f25339b24c441edf d62c698666558242 e5a9e39861fbd81d d2138eacc20d5224 a332c16df23609fb 73f78341dfd74ae5
$h_0^*$	159b52516f10f30d 546b2042f240afee f25339b24c441edf d62c698666558242 e5a9e39861fbd83d 72e259ce420d5a0f 4db37906cc361264 ae579d9e0275b446
$\Delta h_0$	0000000000000000 0000000000000000 0000000000000000 0000000000000000 0000000000000020 a0f1d7628000082b ee81b86b3e001b9f dda01edfdda210a3
$m$	cfbec86f1cf6821e dd3343c25aad835a 2a08612b753f3d6b b328d40d2c624ef7 b3e51f8a3a63bd6f 4abdf96375bbf609 a8c5c1f784672e86 a78e2aa625830d4b 169dcb5039bf3d9f fbcc43ffebd8ae47 1b3eaeffc5c6a46 f668a2a728851b4e 374601ea44422bdb 2ca290d26a23a02f 6685babbfdbc5e22 e000111457201fd4
$m^*$	ee37d77210586a56 b2a4122800ad72cf 89399609f53f3560 b328d40d2c624ed7 b3e51f8a3a63bd6f 4abdf96375bbf609 a8c5c1f784672e86 a78e2aa625830d4b 169dcb5039bf3d9f fbcc43ffebd8ae47 1b3eaeffc5c6a46 f668a2a728851b4e 374601ea44422bfb 0ca290d26a23a03f 6685babbfdbc5e02 e07e151457202055
$\Delta m$	21891f1d0caee848 6f9751ea5a00f195 a331f7228000080b 0000000000000020 0000000000000000 0000000000000000 0000000000000000 0000000000000000 0000000000000000 0000000000000000 0000000000000000 0000000000000000 0000000000000020 2000000000000010 0000000000000020 007e04000003f81
$h_1$	1d7041bbbf6a676a 03d8c440d9246b9d 20ce2d17c5b0b2c4 7e6e4d33a7f54afd

(b) Example of a collision for 27 steps of SHA-512/256.

$m$	306b0c2ebe7c1341 c8b55d4df1c5f4fe b91a173aeceb818a 33b5977f9b46e58b 6c6d5a4f87f1364f 1b7e33249d4acf4f b7f784ecdcaefc1f a33edafe7afc0452 dfc0200932c2b9df faec7d05e3518e56 ec2e19a7ee867396 d490bd22815eb494 72fedf1f887df303 f95891f08483da25 c327d0afa2c4f902 2c5f0c0806a4e298
$m^*$	306b0c2ebe7c1341 c8b55d4df1c5f4fe b91a173aeceb818a 33b5977f9b46e58b 6c6d5a4f87f1364f 1b7e33249d4acf4f b7f784ecdcaefc1f 1d4edd1e3afc0452 d0009fc932c2b9de faec7d05e3518e56 ec2e19a7ee867396 d490bd22815eb494 f0bc01169875f30b f95891f08483da25 c327d0afa2c4f902 d2587c300764e298
$\Delta m$	0000000000000000 0000000000000000 0000000000000000 0000000000000000 0000000000000000 0000000000000000 0000000000000000 be7007e040000000 0fc0bfc000000001 0000000000000000 0000000000000000 0000000000000000 8242de0910080008 0000000000000000 0000000000000000 fe07703801c00000
$h_1$	fcba5c8faf05fd68 c676b8f17b5daae3 6233801174b7fd01 0ff72ab4a869c54f

**Table 11.** Results for SHA-384.

(a) Example of a free-start collision for 41 steps of SHA-384.

$h_0$	500c5f3c4787ba7d a068fcb4011d5bf3 42e5d7f8a8b5379a 7e74fdcc5a87935c f5f415efc47d32d6 26dd61b02c6d0535 c7db5e89eefe94b2 428c2357ed063d18
$h_0^*$	500c5f3c4787ba7d a068fcb4011d5bf3 42e5d7f8a8b5379a 7e74fdcc5a87935c f5f415efc47d32d6 26dd61b02c6d0535 c7db5e89eefe94d2 a76a0e166d06354d
$\Delta h_0$	0000000000000000 0000000000000000 0000000000000000 0000000000000000 0000000000000000 0000000000000000 0000000000000060 e5e62d4180000855
$m$	e13bb65dd3648429 0c1f502f0462116a 537195824dd4d9c3 a79d8323b63058ee 88821d5bb67c9042 d37ee7690e0f79f2 ebefa3e85f97bc7b e9e2ac55d87d9d51 881ea963df122650 210c7bf69ef999c7 b1e4fdb6c5e209ca 3eee8c4a06d943c4 484835ab03c4a2ff 2001ba37b3a01fd8 5ffd223aff721f3f 398994124514202b
$m^*$	7c5dcb9f53648c14 0c1f502f0462116a 537195824dd4d9c3 a79d8323b63058ee 88821d5bb67c9042 d37ee7690e0f79f2 ebefa3e85f97bc7b e9e2ac55d87d9d51 881ea963df122650 210c7bf69ef999c7 b1e4fdb6c5e209ea 1eee8c4a06d943d4 484835ab03c4a2df 207fbc37b3a02059 6001223aff721e3f 398994124514202b
$\Delta m$	9d667dc28000083d 0000000000000020 0000000000000000 0000000000000000 0000000000000000 0000000000000000 0000000000000000 0000000000000000 0000000000000000 0000000000000000 0000000000000020 2000000000000010 0000000000000020 007e040000003f81 3ffc00000000100 0000000000000000
$h_1$	667b472d680391c2 9c41c2626b95724d 3e537e772da88bed cfb5a3b5037bfe e6d7e0d6b53df84d f9667a25301c99e4

(b) Example of a collision for 27 steps of SHA-384.

$m$	3e7553f2cfb535ab c6b10da716e10303 dacfae5c546a644d f583858a09a07330 80f9a52d3920a14d 5cdc569b9d21b864 b1a502c28b3d61d8 e2b122ece7ac4b72 dfc0201101b358e7 8166c65680a5ac4f ab8499afe6873554 d490bd22815eb494 76fedf1f605ff2d3 d88056eb1a397147 aefff39c56655d5b 2d9f834e6cb4f200
$m^*$	3e7553f2cfb535ab c6b10da716e10303 dacfae5c546a644d f583858a09a07330 80f9a52d3920a14d 5cdc569b9d21b864 b1a502c28b3d61d8 5cc1250ca7ac4b72 d0009fd101b358e6 8166c65680a5ac4f ab8499afe6873554 d490bd22815eb494 f4bc01167057f2db d88056eb1a397147 aefff39c56655d5b d398f3766d74f200
$\Delta m$	0000000000000000 0000000000000000 0000000000000000 0000000000000000 0000000000000000 0000000000000000 0000000000000000 be7007e040000000 0fc0bfc000000001 0000000000000000 0000000000000000 0000000000000000 8242de0910080008 0000000000000000 0000000000000000 fe07703801c00000
$h_1$	dc3c054014ee5e3b 4da7c81dba383c4e d9997f5a26fe5f59 d987d2e5bc2f7e83 46ba52d79f525f95 90c5db2cc94e87ee

**Table 12.** Results for SHA-512.

(a) Example of a semi-free-start collision for 39 steps of SHA-512.

$h_0$	eccf3da189dd9668 b1ec21a4fd53b8d8 609ce4465f772770 adf4e7738e2978f6 8edd237ea50eebc9 231b3af0102a926d db45e613e8d2fd52 ad384433420073f6
$m$	a0ec9872cffffe63c df5c6a2b59f4c453 f2bea3763fc8fa7a 6a47e8ff0a995116 fa59232e8b617048 4c9690984c084498 28bee8f5701eab16 8d57686ecbdce623 3879318f901ff782 72644b0ca55a6142 6cb281dab11480b4 4a8198441f401ff2 5ffd956ed11a2b5f 9a640988d68287d3 74942df792f2637f b2819dc61f772d4f
$m^*$	a0ec9872cffffe63c df5c6a2b59f4c453 f2bea3763fc8fa7a 6a47e8ff0a995116 fa59232e8b617048 4c9690984c084498 28bee8f5701eab16 8d57686ecbdce623 3879318f901ff7a2 52644b0ca55a6152 6cb281dab1148094 4aff9c441f402073 6001956ed11a2a5f 9a640988d68287d3 74942df792f2637f b2819dc61f772d4f
$\Delta m$	0000000000000000 0000000000000000 0000000000000000 0000000000000000 0000000000000000 0000000000000000 0000000000000000 0000000000000000 0000000000000020 2000000000000010 0000000000000020 007e040000003f81 3ffc00000000100 0000000000000000 0000000000000000 0000000000000000
$h_1$	3aa73bfae7b82789 711f2024cf0f636e 0c6965f707279a53 8227fba8617aa955 fdd9e2ca8c4d0038 57db244560d7b70b 08ec5698343353c0 9e9b739ee307ea92

(b) Example of a collision for 27 steps of SHA-512.

$m$	537e7a4986aa2fce 11206ad0306c752b 90124a9e1c9b0ce2 8c14e0356fd26f5f fd3ef90ea3e4366f 35d8c2ba58abd92f b23e476632eca1fd e2b122ef46649b73 dfc020070e628f37 7acf74d1d1007558 6c6359a6fe7fe2f0 d490bd22815eb494 72fedf1f807df6f3 a8585af19b6dd9d1 3d2053b0c295522b 2d970e0e52a49081
$m^*$	537e7a4986aa2fce 11206ad0306c752b 90124a9e1c9b0ce2 8c14e0356fd26f5f fd3ef90ea3e4366f 35d8c2ba58abd92f b23e476632eca1fd 5cc1250f06649b73 d0009fc70e628f36 7acf74d1d1007558 6c6359a6fe7fe2f0 d490bd22815eb494 f0bc01169075f6fb a8585af19b6dd9d1 3d2053b0c295522b d3907e3653649081
$\Delta m$	0000000000000000 0000000000000000 0000000000000000 0000000000000000 0000000000000000 0000000000000000 0000000000000000 be7007e040000000 0fc0bfc000000001 0000000000000000 0000000000000000 0000000000000000 8242de0910080008 0000000000000000 0000000000000000 fe07703801c00000
$h_1$	d838f1d2ae4bf185 3fc837ae9bbc28d4 6b2f2977f58a9697 99c48839f0e8bdca c9c0a86fed1d921a 2f823b1fa1913751 3ba170b902c6da30 9c4e5807be51a7e7

**Table 13.** Results for SHA-224.

(a) Example of a free-start collision for 39 steps of SHA-224.

$h_0$	5594e74a 2234bcbd 635966b5 97a9e488 4a6a7d63 7c28ca05 f1384c84 d2c9753a
$h_0^*$	5594e74a 2234bcbd 635966b5 97a9e488 4a6a7d63 7c28ca05 f1384c84 d2c97532
$\Delta h_0$	00000000 00000000 00000000 00000000 00000000 00000000 00000000 00000008
$m$	949722de 48501dcc 7fe48849 ba821c7a 5b5a1e6f 30c487c8 401134e4 2d9eacc7 dd15d12f 9079b000 37c75e69 a47f0dde 8baaf91a d348cc06 2b64ef59 011f91be
$m^*$	949722e6 48501dcc 7fe48849 ba821c7a 5b5a1e6f 30c487c8 401134e4 2d9eacc7 e373cfef 9079affc 37c75e69 a4808dde 8baaf91a d348cc06 2b64ef59 011f91be
$\Delta m$	00000038 00000000 00000000 00000000 00000000 00000000 00000000 00000000 3e661ec0 00001ffc 00000000 00ff8000 00000000 00000000 00000000 00000000
$h_1$	1d6d980a 2aa5f9c0 9843296b da4f8baa 09c36608 7e2bdad9 cb0f1654

(b) Example of a collision for 28 steps of SHA-224.

$m$	a3e2972c 73ba31f5 e9f85a00 c2cb8cbc 4dd15d27 d240b6f6 0c1243ec 07504bfd 134d0e53 fb839dcc e14f2cbc 53c3c1c6 6ac516a7 a19b112f d844f621 939e7e53
$m^*$	a3e2972c 73ba31f5 e9f85a00 c2cb8cbc 4dd15d27 d240b6f6 0c1243ec 07504bfd e3f85ef3 f75b9934 e14f2cbc 53c3c1c6 6ac516a7 a3db19bf d844f621 939e7e53
$\Delta m$	00000000 00000000 00000000 00000000 00000000 00000000 00000000 00000000 f0b550a0 0cd804f8 00000000 00000000 00000000 02400890 00000000 00000000
$h_1$	869fd0b5 fb96d20b 28177d1e c7af4885 06ecb162 88332da4 5022b6c7