

Analysis of Stepped-Impedance Microstrip Low Pass Filter for L-Band Applications

Surabhi Patankar

Dept.of Electronics & Communication Engineering,
 Rustamji Institute of Technology,BSF Tekanpur,
 Gwalior, India,

Devendra Kumar

Dept.of Electronics & Communication Engineering,
 Rustamji Institute of Technology, BSF, Tekanpur,
 Gwalior, India,

Abstract--This paper presents stepped impedance low pass filter based on defected ground structure (DGS) cells. The proposed DGS cell provides low-pass characteristic whose cutoff frequency could be changed by tuning its dimensions. Design and analysis of the stepped impedance microstrip low pass filter has been described using CST software tool. In this paper, 5th order stepped impedance low pass microstrip line filter have been designed at 1.4 GHz frequency and implemented on FR/4 substrate of relative permittivity is 4.3.

Keywords-- Low Pass Filter, Microstrip, Stepped Impedance Configuration

I. INTRODUCTION

A microwave filter is a two-port network used to control the frequency response at certain point in a microwave system by providing transmission at frequencies within the passband of the filter and attenuation in the stopband of the filter. Microwave filter designs have been at the forefront of research in both industry and academia due to increasing specification levels and demand for advanced communication systems. Planar microstrip filters, which possess compact size, low cost, flexible layout and easy fabrication, are preferably integrated in low power transceiver systems [1].

The realizable filters that are in common use are Butterworth filter, Chebyshev filter and Bessel filter. Utilization of Butterworth low pass filter exist contradiction problems between test precision, stability and response time. Low order Butterworth low pass filter has rapid response, small overshoot but bad in test precision, while high order Butterworth low pass filter is good in test precision but has slow response, large overshoot and poor stability [2]. The type of construction of this filter is a reflective filter which is consists of capacitive and inductive elements producing ideally zero reflection loss in the pass band region and very high attenuation in the stop band region. The practical filters have small non-zero attenuation in the pass band a small signal output in the attenuation or stop band due to the presence of resistive losses in reactive elements of propagating medium [3].

II. FILTER DESIGN PROCEDURE

Figure 1 shows a general structure of the stepped-impedance lowpass microstrip filters, which use a cascaded structure of alternating high- and low impedance

transmission lines. These are much shorter than the associated guided- wavelength, so as to act as semi lumped elements. The high-impedance lines act as series inductors and the low-impedance lines act as shunt capacitors. Therefore, this filter structure is directly realizing the L-C ladder type of lowpass filters of figure 2.

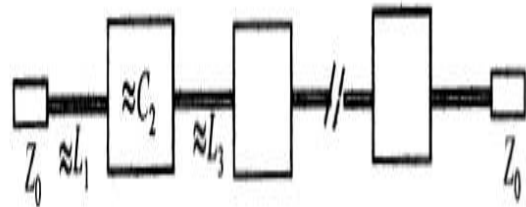

Fig 1. General structure of the stepped-impedance lowpass microstrip filter.

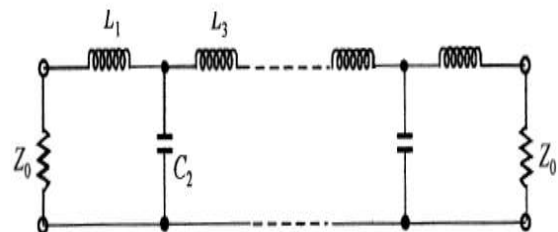

Fig 2. L-C ladder type of lowpass filter.

LPF was design at the cut off frequency of $f_c=1\text{GHz}$ and formula which is used for the design of LPF is

Synthesis of W/h

$$\frac{W}{h} = \frac{8 e^A}{e^{2A} - 2} \quad (1)$$

With

$$A = \frac{Z_c}{60} \left[\frac{\epsilon_r + 1}{2} \right]^{0.5} + \frac{\epsilon_r + 1}{\epsilon_r + 1} \left[0.23 + \frac{0.11}{\epsilon_r} \right] \quad (2)$$

Where $Z_c=Z_0 = 50\Omega$ and ϵ_r (dielectric constant) = 4.4, W = width, h = height of dielectric which is taken as 1.6mm.

Effective dielectric constant of dielectric material given by equation (13) and (14)

For $W/h \leq 1$:

$$\epsilon_{re} = \frac{\epsilon_r + 1}{2} + \frac{\epsilon_r - 1}{2} \left(1 + 12 \frac{h}{w}\right)^{-0.5} \quad (3)$$

For $W/h > 1$

$$\epsilon_{re} = \frac{\epsilon_r + 1}{2} + \frac{\epsilon_r - 1}{2} \left[\left(1 + 12 \frac{h}{w}\right)^{-0.5} + 0.04 \left(1 - \frac{w}{h}\right)^2 \right] \quad (4)$$

Whereas guided wavelength is given by equation (5)

$$\lambda_g = \frac{300}{f(\text{GHz})\sqrt{\epsilon_{re}}} \quad (5)$$

ϵ_{re} = Effective dielectric constant , f = 1.5 GHz.

Values of inductor and capacitor are given by

$$C_i = \frac{1}{2\pi Z_0 f_c} g'_i, L_i = \frac{1}{2\pi f_c} Z_0 g_i \quad (6)$$

For $i = 1, 2, 3, \dots, 6$.

Calculation of length of inductor and capacitor is done using formula

$$l_{Li} = \frac{\lambda_{gL}(f_c)}{2\pi} \sin^{-1} \left(2\pi f_c \frac{L_i}{Z_{oc}} \right) \quad (7)$$

$$l_{Ci} = \frac{\lambda_{gc}(f_c)}{2\pi} \sin^{-1} (2\pi Z_{oc} C_i) \quad (8)$$

Table I Dimension of the Stepped Impedance Low Pass Filter for 5th order

$Z_i=ZL=ZC(\Omega)$	$W_i(\text{mm})$	$l_i(\text{mm})$
93	0.652	10.79
24	8.822	11.96
93	.652	23.4
24	8.822	11.96
93	0.652	10.79
50	5	5.55

The proposed design of low pass filter shown in figure 3(a) and 3(b).

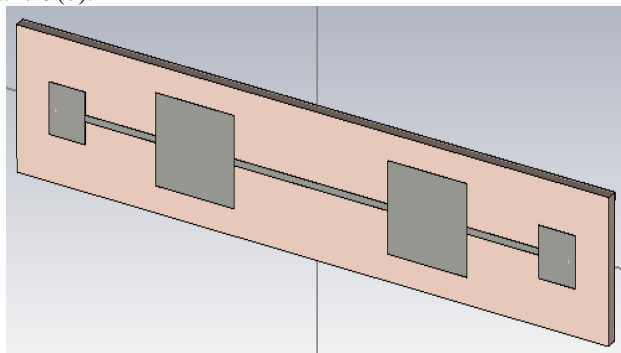

(a) Front View

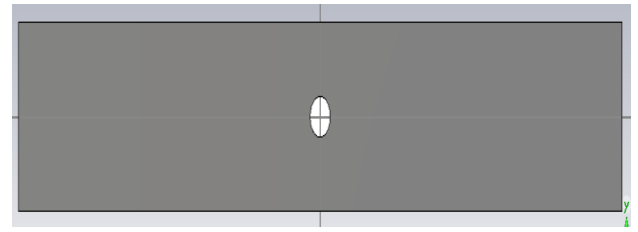

(b) Back View

Fig 3. (a) front view of Layout of the designed microstrip stepped impedance function LPF (b) Back view of ground structure of the designed microstrip stepped impedance function LPF.

The proposed design of the stepped impedance Low Pass Filter is shown in the figure 5. FR4 lossy material with dielectric constant of 4.4, substrate height of 1.6mm and loss tangent 0.02 used. A hole of circular shaped of diameter 3mm is introduced in the ground plane which affects the ground as defected.

The graphs obtain after the simulation CST Software shown in figure 4. From the graph it is clear that the cut-off frequency is found to be 1.5GHz for stepped-impedance low pass filter. Hence stepped impedance low pass filter is capable of passing the frequency less than 1.5GHz & reject the frequency after 1.5GHz for the thickness of the substrate 1.6 mm and relative dielectric constant 3.7

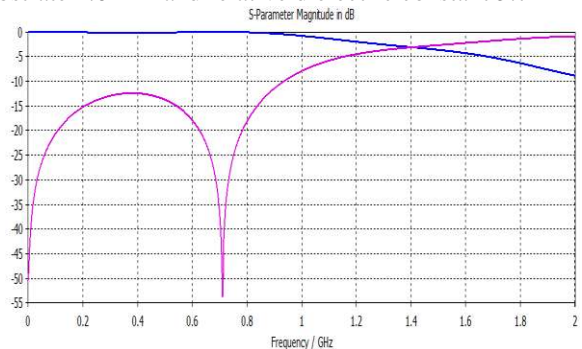

Fig 3. Simulated result of stepped impedance 5th order low pass filter with DGS.

CONCLUSION

Fifth order Stepped impedance Low Pass Filter is design and simulate for the frequency of 1.5GHz. After design and producing a ground as a defected structure, the cut off frequency is found at sharp 1.4GHz. This range of filter is widely used for L-band applications. So for the application where very sharp rate of cutoff and reduced label of fluctuation of response is needed than use DGS for designing filter should be proposed.

ACKNOWLEDGMENT

The author is thankful to M.Tech, Department of Electronics and Communication Engineering, S.E.T., I.F.T.M. University, Moradabad (U.P.), India to provide assistance to complete this work.

REFERENCE

- [1] R. Levy, R. V. Snyder, and G. Matthaei, "Design of microwave filters," *IEEE Trans. Microw. Theory Tech.*, vol. 50, PP. 783-793, March 2002.
- [2] Li Zhongshen, "Design and Analysis of Improved Butterworth Low Pass Filter" The Eighth International Conference on Electronic Measurement and Instruments ICEMI'2007.
- [3] A. Casanueva, A. León, O. González, and A. Mediavilla, "A compact microstrip step-impedance low-passfilter (SILPF) using complementary split ringresonators" IEEE MTT-S International Microwave Workshop on Wireless Sensing, Local Positioning, and RFID (IMWS 2009 - Croatia).
- [4] Anju and Mamta Katiyar, "Design of Butterworth and Chebyshev 1 Low pass Filter for Equalized Group Delay," *International Journal of Advanced Research in Computer Science and Software Engineering*, vol. 2, Issue 5, May 2012.
- [5] D. Kumar, A. De, "Effective Size Reduction Technique for Microstrip Filters", *Journal of Electromagnetic Analysis and Applications*, 2013, 5, 166-174.
- [6] Garvansh, Abhay Singh Kushwaha, Navita Singh, Arun Kumar, "Implementation of Stepped Impedance Low Pass Microstrip Line Filter for Wireless Communication" *International Journal of Advanced Research in Computer and Communication Engineering* Vol. 3, Issue 7, July 2014.
- [7] Pozar, David M. "Microwave Engineering" 2nd Edition, USA: John Wiley & Sons/ D. M. Pozar, "Microwave engineering newyork," *John Wile Yand Sons, Third Edition*.
- [8] Jia-Sheng Hong, M. J. Lancaster "Microstrip filters for RF / Microwave Application" A Wiley-Interscience Publivation book.
- [9] CST (computer Simulation Technology) microwave software studio 2010.



Surabhi Patankar was born in 1991 in India. She received the BE degree in Electronics & Communication Engineering from Gwalior engineering college (India) and M.Tech in Communication system pursuing from in Rustamji institute of Technology, Gwalior (India). Her area of interests includes Microwave Filters.



Devendra Kumar was born in 1969 in India. He received the BE degree in Electronics & Communication from Institution of Engineers (India) and M Tech in Electronics & Communication from MITS Gwalior (India). His area of interests include Microwave Antenna, Filters and Radar. He worked on Radio, Radar and Navigational systems in defense sector from 1987 to 2007. Presently he is working as an Assistant Professor in department of electronics & communication engineering in Rustamji institute of Technology, Gwalior (India), since 16 Aug 2010.