

Analysis of Stub Loaded Microstrip Patch Antennas

M. D. Deshpande*

ViGYAN Inc., 30 Research Drive, Hampton

M. C. Bailey

NASA Langley Research Center, Hampton.

A microstrip patch antenna fed by a coaxial probe and reactively loaded by an open circuited microstrip line has been used previously to produce circular polarization [1] and also as a building block for a series fed microstrip patch array [2]. Rectangular and circular patch antennas loaded with a microstrip stub were previously analyzed using the generalized Thevenin theorem [2,3]. In the Thevenin theorem approach, the mutual coupling between the patch current and the surface current on the stub was not taken into account. Also, the Thevenin theorem approach neglects continuity of current at the patch-stub junction. The approach in this present paper includes the coupling between the patch and stub currents as well as continuity at the patch-stub junction.

The input impedance for a stub loaded microstrip patch is calculated by the general planar dielectric dyadic Green's function approach in the spectral domain, as was initiated much earlier [4] and has been extensively expanded upon and utilized successfully throughout the literature for microstrip antenna configurations. Using the spectral domain dyadic Green's function derived earlier [5] with the electric field integral equation (EFIE), the problem is formulated by using entire domain basis functions to represent the surface current densities on the patch, the loading stub and the attachment mode at the junction. Galerkin's procedure is used to reduce the EFIE to a matrix equation, which is then solved to obtain the amplitudes of the surface currents. These surface currents are then used for calculating the input impedance of stub loaded rectangular and circular microstrip patches. Numerical results are compared with measured results and with previous results calculated by the Thevenin's theorem approach.

Figure 1 shows the geometry of a stub loaded rectangular microstrip patch antennas. The patch is fed by a coaxial probe and loaded with a narrow strip, open on one end. The surface currents on the rectangular patch are expressed by the superposition of x- and y-directed currents as:

$$\vec{J}_1 = \hat{x}J_{1x} = \hat{x}\frac{I_1}{W_x}\cos\left(\frac{\pi(x-W_x/2)}{W_x}\right)\delta(z-d) \quad \text{and} \quad \vec{J}_2 = \hat{y}J_{2y} = \hat{y}\frac{I_2}{W_y}\sin\left(\frac{\pi(y-W_y/2)}{W_y}\right)\delta(z-d).$$

The surface current on the stub is expressed as:

$$\vec{J}_3 = \hat{x}J_{3x} = \hat{x}\frac{I_3}{L_{st}}\cos\left(\frac{\pi(x-x_{st})}{L_{st}}\right)\delta(z-d), \quad \text{where } (x_{st}, y_{st}) \text{ are the coordinates of the}$$

center point on the stub, (L_{st}, W_{st}) are the length and width, respectively, of the microstrip stub. Likewise, the attachment mode current is written

as: $\vec{J}_4 = \hat{x}J_{4x} = \hat{x}\frac{I_4}{W_{at}} \cos\left(\frac{\pi(x-x_{at})}{L_{at}}\right) \delta(z-d)$, where (x_{at}, y_{at}) are the coordinates of the center point on the attachment region, (L_{at}, W_{at}) are the length and width, respectively, of the attachment region. In the present case we set $W_{st} = W_{at}$, and $L_{at} = 2L_{st}$. The surface current density for the circular patch calculations is presented by Bessel functions (see [6]).

For validation of the present approach, an example of a rectangular patch having dimensions $W_x = 5.55\text{cm}$, $W_y = 6.9\text{cm}$ etched on a substrate of relative permittivity $\epsilon_r = 2.5 - j0.0025$ and thickness $d = z' = 0.079\text{cm}$ was considered. The patch was assumed to be excited by a coaxial probe (diameter $d_0 = 0.1\text{cm}$) located at $x_s = 0.07\text{cm}$ and $y_s = 3.45\text{cm}$. Also it was assumed that the rectangular patch was loaded at $x_{st} = 5.55\text{cm}$ and $y_{st} = 3.45\text{cm}$ with a microstrip stub of $W_{st} = 0.05\text{cm}$ and length L_{st} . First the input impedance of the unloaded patch was computed using the present theory as a function of frequency. The normalized input impedance at the resonant frequency, 1.676 GHz was found to be $(3.08+j0.0)$. The input impedance of the loaded patch is then calculated as a function of stub length L_{st} and presented in figure 3 along with the calculated and experimental results obtained from ref. [2]. There is good agreement between the results obtained using the present method and the results reported in [2]. In the calculated results shown in figure 3, the width of the microstrip stub was taken as the effective width which is equal to $W_{st} + 2d$.

For further validation of the present approach, an example of a circular patch having diameter $2a = 4.11\text{cm}$, etched on a substrate of relative permittivity $\epsilon_r = 2.64 - j0.00264$ and thickness $d = z' = 0.16\text{cm}$ was considered. The patch was assumed to be excited by a coaxial probe (diameter $d_0 = 0.12\text{cm}$) located at $\rho_0 = 0.6\text{cm}$ and $\phi_0 = 270^\circ$. Also it was assumed that the circular patch was loaded at $\rho_{st} = 2.05\text{cm}$ and $\phi_{st} = 90.0^\circ$ with a microstrip stub of $W_{st} = 0.4\text{cm}$ and length $L_{st} = 1.0\text{cm}$. The measured and calculated are presented in figure 4 over the frequency range of 2.2 - 2.7 GHz. The effective width of the microstrip stub was used in the calculation. The numerical results obtained using the present approach agree well with the measured results.

- [1] M. Heneishi, et al., "A design of back-feed type circularly polarized microstrip disk antennas having symmetrical perturbation element by one-point feed", J. E. Tehan, "Analysis of a microstrip array and feed network," IEEE Trans.

AP-33,(4) pp. 397-403, April 1985.

- [3] M. D. Deshpande and Y. R. Rao, " Analysis of reactively loaded microstrip disk, " Proc. IEE, Vol. 136, Pt. H, No. 5, Oct. 1989.
- [4] M. C. Bailey, "Analysis of the properties of microstrip antennas using strips embedded in a grounded dielectric slab, " 1979 International Symposium Digest APS, Vol. I, IEEE 1979, pp. 370-373
- [5] M. C. Bailey and M. D. Deshpande, "Integral equation formulation of microstrip antennas, "IEEE Trans. Antennas Propagat., Vol. AP-30, No. 4, pp. 651-656, July 1982.
- [6] M. C. Bailey and M. D. Deshpande, "Analysis of elliptical and circular microstrip antennas using method of moments," IEEE Trans. Antennas Propagat., Vol. AP-33, No. 9, pp. 954-959, September 1985

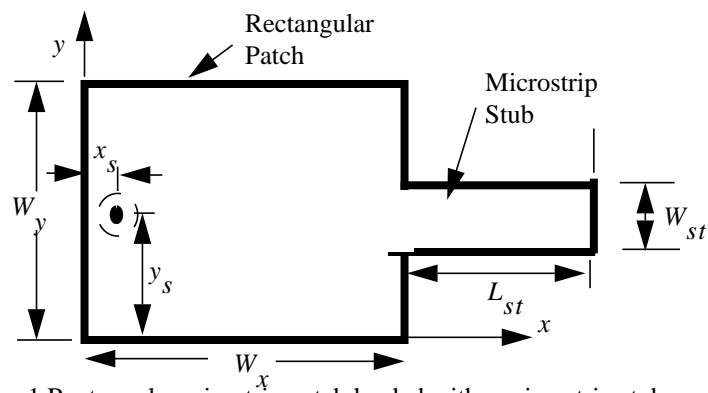

Figure 1 Rectangular microstrip patch loaded with a microstrip stub.

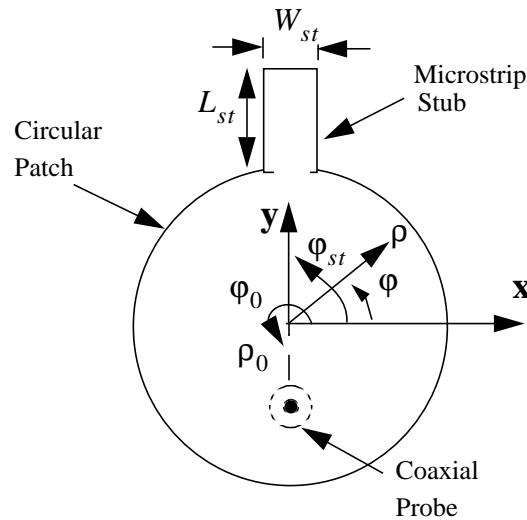

Figure 2 Circular patch of diameter 2a loaded with microstrip stub.

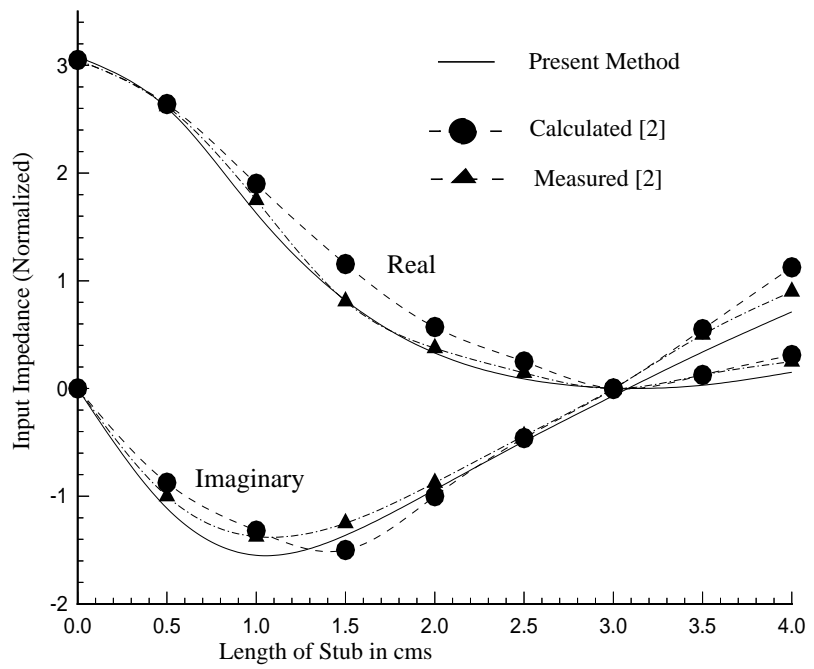

Figure 3 input impedance of rectangular microstrip antenna

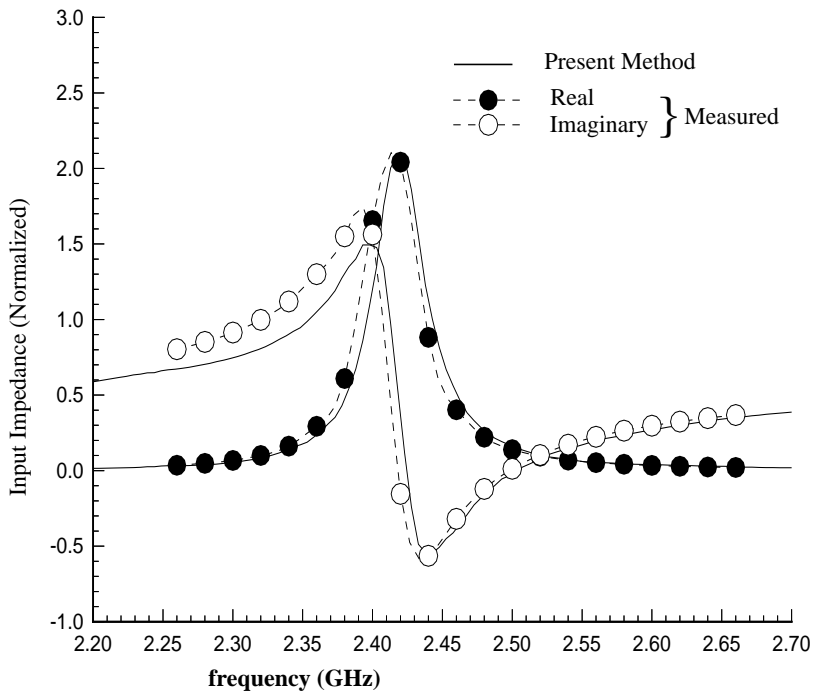

Figure 4 Input impedance of a circular patch ($2a = 4.11\text{cm}$) loaded with microstrip stub as shown figure 2.