

Analysis of the Effects of Phase-Noise in Orthogonal Frequency Division Multiplex (OFDM) Systems

Patrick Robertson and Stefan Kaiser *

German Aerospace Research Establishment (DLR), Institute for Communications Technology
D-82230 Oberpfaffenhofen, Germany, Tel.: ++49 8153 28 2808 (2805); FAX: ++49 8153 28 1442

Abstract

In OFDM transmission schemes, phase-noise from oscillator instabilities in the receiver is a potentially serious problem, especially when bandwidth efficient, high order signal constellations are employed. The paper analyses the two effects of phase-noise: inter-carrier interference (ICI) and a phase error common to all OFDM sub-carriers. Through numerical integration, the ICI power can be evaluated and is shown as a function of the number of OFDM sub-carriers and various parameters of the phase-noise model. Increasing the number of sub-carriers causes an increase in the ICI power, which our analysis indeed shows to become a potential problem, since it can lead to a BER floor. The analysis allows the design of low-cost tuners through specifying the required phase-noise characteristics. A similar technique is applied to calculate the variance of the common phase error. After showing that the common phase error is essentially uncorrelated from symbol to symbol, we propose a simple feed-forward correction technique based on pilot cells, that dramatically reduces the degradation due to phase-noise. This is confirmed by BER simulations of a coded OFDM scheme with 64 QAM.

1 Introduction

In this paper, we will discuss the effects of phase-noise on digital transmission systems using OFDM with a high number of sub-carriers. Typical applications can be audio, TV and HDTV transmission over terrestrial channels. OFDM has been proposed for terrestrial broadcasting because of its high spectral efficiency and robustness in the case of long echoes, but has a number of disadvantages too, such as behaviour in the case of non-linearities and quite severe carrier synchronization requirements [1]. Phase-noise is also a potentially serious problem because of the common necessity to employ relatively low cost tuners in the receivers. Low cost tuners are associated with less good phase-noise characteristics, i.e. their output spectrum cannot be modelled by a Dirac delta at the centre frequency, but rather as a delta surrounded by noise with certain spectral characteristics.

The effects of this phenomenon are heightened due to the fact that, for example, TV and HDTV transmissions often use high order modulation formats to transmit a signal with a high data rate over the available channel (e.g. 8 MHz). For transmission of TV and HDTV signals, 64 QAM modulation with OFDM has been suggested [2], and this constellation is particularly sensitive to phase-noise: on the one hand phase-noise causes inter-carrier interference (due to the non-

orthogonality after mixing with a 'noisy' local oscillator); on the other hand a further degradation is the result of the so called common phase error.

The paper is organized as follows: we shall begin by introducing a simple phase-noise model that is the basis for subsequent simulations and analysis. We will then focus on the two effects that phase-noise will have on the OFDM transmission: ICI and the common phase error. This is followed by numerical evaluation of the effects, and we shall show the importance of the number of OFDM sub-carriers and parameters of the phase-noise model. Motivated by the theoretical analysis, we will present a feed-forward method of combating phase-noise (as far as possible) and shall conclude the contribution by showing simulation results of the feed-forward correction technique applied to a coded OFDM scheme proposed for terrestrial transmission of digital television.

2 The Phase-Noise Model

To model the phase-noise in the receiver's local oscillator(s) we assume instability of the phase only, and no deviation of the centre frequency or amplitude. The model is taken from [3] which is based on [4]. It has been accepted as a reference in the European dTTb project.

The complex oscillator output (in baseband notation) can be written as

$$\eta(t) = e^{j\varphi_N(t)} \approx 1 + j \cdot \varphi_N(t), \quad (1)$$

the approximation holding when $\varphi_N(t) \ll 1$, which is a valid assumption (no frequency deviation). The power density spectrum (PDS) of $\eta(t)$ is given through the PDS of $\varphi_N(t)$, which can be obtained through measurements of a real tuner using a PLL. For the PDS of φ_N the model specifies [3]:

$$L_{\varphi_N}(f) = 10^{-c} + \begin{cases} 10^{-a} & : |f| \leq f_1 \\ 10^{-(f-f_1) \cdot \frac{b}{f_2-f_1} - a} & : f_1 < f \\ 10^{(f+f_1) \cdot \frac{b}{f_2-f_1} - a} & : f < -f_1 \end{cases} \quad (2)$$

Typical parameters are: $a = 6.5$, $b = 4$, $c = 10.5$, $f_1 = 1$ kHz and $f_2 = 10$ kHz. A plot of $L_{\varphi_N}(f)$ for these values is shown in Fig. 1. The parameter c determines the noise floor, here at -105 dB, parameter a and f_1 the characteristics of the PLL. The steepness of the linear slope of the curve is given by b , here we assume a reduction in the noise level by 40 dB/decade. The frequency f_2 is where the noise-floor becomes dominant. Later we will vary the important parameters a and c , since they are particularly dependent on the tuner technology used.

*The authors are within the European dTTb-Race and German HDTV-T projects

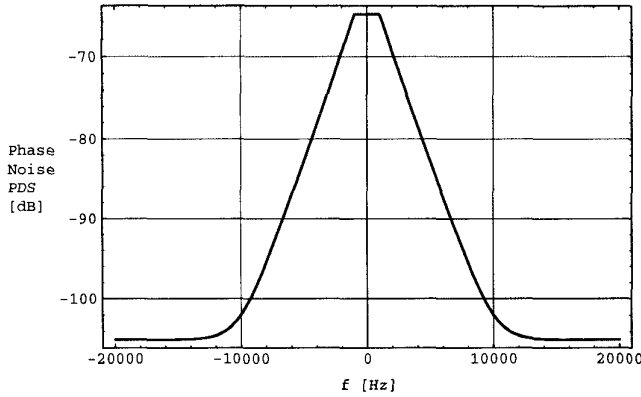

Figure 1: PDS $L_{\varphi_N}(f)$ of the modelled phase-noise process

3 The OFDM Transmission Scheme Including Phase-Noise

The principle of OFDM is to transmit information over a large number of orthogonal sub-carriers, thus making the symbol time very long compared to single carrier systems. By including a guard interval longer than the longest echoes of the channel in each OFDM symbol, no traditional channel equalizer to resolve ISI is needed [5], but a channel estimation operating in the frequency domain instead. For correct demodulation, orthogonality of the sub-carriers is essential, and this is threatened in the receiver either by phase-noise or incorrect carrier frequency synchronization.

Fig. 2 shows the OFDM transmission scheme with N sub-carriers which we have modelled here with a perfect channel. The transmitted signal only suffers from phase-noise due to oscillator instabilities in the tuner. $d_{k,l}$ are the transmitted data symbols where k indicates the OFDM sub-carrier and l the OFDM symbol. The demodulated data symbols in the receiver are written as $r_{k,l}$ and $\varphi_N(t)$ represents the phase-noise. The sub-carrier frequencies are $\omega_k = 2\pi f_k$, spaced by $1/T$ where $T = N/B$ equals the symbol duration. The signal bandwidth B is assumed to be constant at 8 MHz in the examples. The OFDM signal can be formed by a simple inverse FFT as shown in [5, 6]. The received OFDM signal has to be sampled with the frequency $1/T$. For simplicity we do not consider the guard interval in the following, without loss of generality.

3.1 Simplified model assuming one transmitted sub-carrier

In the sequel we shall assume that only one OFDM sub-carrier with index n is active and all other sub-carriers $m \neq n$ have $d_{m,l} = 0$. The reason this is allowed for the analysis of the ICI is that under the assumptions of linearity and that normally all $d_{k,l}$ are independent, the ICI noise components from all sub-carriers can be superimposed. Furthermore, we shall be interested only in one received sub-carrier (index k). The common phase error can also be analysed for this one sub-carrier (see section 5). The transmission model is shown in Fig. 3 a).

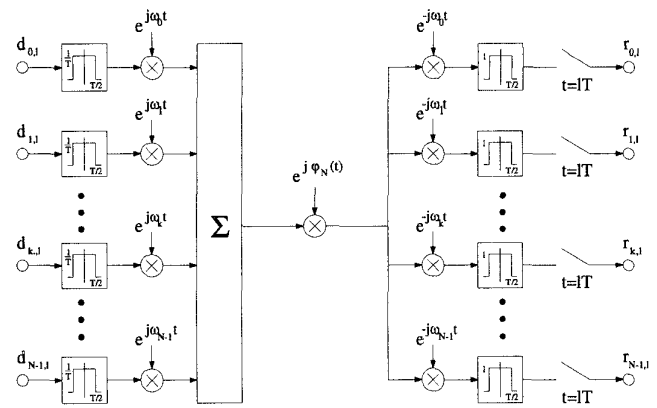

Figure 2: OFDM transmission scheme including phase-noise

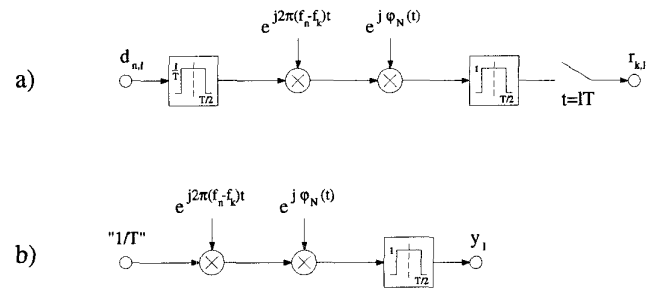

Figure 3: Simplified transmission models: a) assuming only one active sub-carrier and observing received sub-carrier k ; b) setting $d_{n,l} = 1 \forall l$ allows one to ignore the sampling when determining the variance of the samples $r_{k,l}$

4 Inter-Carrier Interference due to Phase-Noise

We shall now assume that sub-carrier n will disturb sub-carrier k , since we can later superimpose disturbances from all sub-carriers $\neq k$, by simply summing over n . In order to continue, the model of Fig. 3 a) must be further simplified. To determine the variance of the samples $r_{k,l}$ (for a given power of $d_{n,l}$), the sampling can be ignored if we are able to set $d_{n,l} = 1, \forall l$ and if the phase-noise process is stationary. The former restriction can be justified since the system is linear and the data of one OFDM symbol l will not affect the output of the receiver for other OFDM symbols $\neq l$. In this case the variance of y_l will equal that of $r_{k,l}$ as long as $E\{d_{n,l}^2\} = 1$. This leads to the simple model of Fig. 3 b) where we need to calculate the variance of y_l , since the ICI from sub-carrier n on k is the signal y_l : the real valued (useful) component of $\eta(t)$ in (1) results in no component in y_l as the sub-carriers n and $k \neq n$ are spaced by multiples of $1/T$. It is easy to show using (1) that the PDS of the ICI is approximately

$$L_{y_l}(f) \approx L_{\varphi_N}(f - [f_n - f_k]) \cdot \text{sinc}^2(\pi f T). \quad (3)$$

Now the ICI variance is the integral

$$\sigma_{y_I}^2(n, k) \approx \int_{-\infty}^{\infty} L_{\varphi_N}(f - [f_n - f_k]) \cdot \text{sinc}^2(\pi f T) df, \quad (4)$$

as the ICI has zero mean. Unfortunately, the integral did not yield to analytical solution as far as the lower two terms in the bracket in (2) are concerned. The frequency constant term and the term for $|f| \leq f_1$ are both integratable since there the noise PDS is flat. Therefore, in subsequent evaluation the two remaining integrals in

$$\begin{aligned} \sigma_{y_I}^2(n, k) \approx & \int_{f_1+f_n-f_k}^{\infty} 10^{-(f-[f_n-f_k]-f_1) \cdot \frac{b}{f_2-f_1}-a} \cdot \text{sinc}^2(\pi f T) df + \\ & \int_{-\infty}^{-f_1+f_n-f_k} 10^{(f-[f_n-f_k]+f_1) \cdot \frac{b}{f_2-f_1}-a} \cdot \text{sinc}^2(\pi f T) df + \\ & \frac{N-1}{10^c T} - \frac{\cos(2\pi z) + 2\pi \text{Si}(2\pi z) \cdot z - 1}{2\pi^2 10^a (f_n - f_k - f_1) T^2} + \\ & \frac{\cos(2\pi z') + 2\pi \text{Si}(2\pi z') \cdot z' - 1}{2\pi^2 10^a (f_n - f_k + f_1) T^2}, \end{aligned} \quad (5)$$

had to be solved numerically. For brevity, we have defined $z = n - k - f_1 T$ and $z' = n - k + f_1 T$.

We can assume the worst case when the affected sub-carrier k is located in the center of the frequency band, which corresponds to $k = N/2$, and sum over n to finally obtain the following bound (equality for the worst case $k = N/2$) for the ICI power:

$$P_{ICI} \leq \sum_{\substack{n=0 \\ n \neq \frac{N}{2}}}^{N-1} \sigma_{y_I}^2(n, k). \quad (6)$$

One can model this noise as Gaussian distributed, because of the large number of contributing sub-carriers (central limit theorem). Note that the useful power in the case of no phase-noise is equal to 1.

5 The Common Phase Error

So far, we have analysed the ICI due to phase-noise and we will now look at the additional perturbations caused by phase-noise besides the ICI. We will prove that each sub-carrier is affected by a common phase error Φ_{E_l} that is only a function of the OFDM symbol index l . Let us consider the special case in Fig. 3 a) where $n = k$. The samples $r_{k,l}$ are given by

$$r_{k,l} = \int_{-iT-\frac{T}{2}}^{-iT+\frac{T}{2}} \frac{d_{k,l}}{T} \cdot e^{j\varphi_N(\tau)} d\tau = d_{k,l} \cdot \int_{-iT-\frac{T}{2}}^{-iT+\frac{T}{2}} \frac{e^{j\varphi_N(\tau)}}{T} d\tau. \quad (7)$$

Hence we have shown that the output samples are multiplied by a disturbance that is identical for all sub-carriers k and that only varies from one OFDM symbol to the next. Since the magnitude of the integral in the right half of (7) is close

to one, the symbols $d_{k,l}$ will be disturbed by a common phase error, which for OFDM symbol l we define as:

$$\Phi_{E_l} = \arg \left\{ \frac{r_{k,l}}{d_{k,l}} \right\} \approx \text{Im} \left\{ \frac{r_{k,l}}{d_{k,l}} \right\} \approx \int_{-iT-\frac{T}{2}}^{-iT+\frac{T}{2}} \frac{\varphi_N(\tau)}{T} d\tau, \quad (8)$$

where we assume $\arg \left\{ \frac{r_{k,l}}{d_{k,l}} \right\}$ is small.

5.1 Variance

It is useful to evaluate the variance of Φ_{E_l} , since this is an important measure used to determine the degradation of transmission quality due to the common phase error. We obtain:

$$\sigma_{\Phi_E}^2 = E \{ \Phi_{E_l}^2 \} - (E \{ \Phi_{E_l} \})^2 \approx E \left\{ \left(\frac{1}{T} \int_{-iT-\frac{T}{2}}^{-iT+\frac{T}{2}} \varphi_N(\tau) d\tau \right)^2 \right\}, \quad (9)$$

since the phase-noise has zero mean. Because the phase-noise process is stationary, we can write the PDS of the common phase error as

$$L_{\Phi_E}(f) \approx \frac{1}{T^2} \cdot L_{\varphi_N}(f) \cdot \text{sinc}^2(\pi f T) \cdot T^2, \quad (10)$$

and

$$\sigma_{\Phi_E}^2 \approx \int_{-\infty}^{\infty} L_{\varphi_N}(f) \cdot \text{sinc}^2(\pi f T) df, \quad (11)$$

(which is equivalent to setting $k = n$ in (4)). Further evaluation is possible by inserting $k = n$ into (5).

5.2 Auto-correlation function

It is interesting to look at the correlation of the common phase error between adjacent OFDM symbols because if the correlation is high, feeding back the common phase error to correct before the FFT (frequency de-multiplexing) in the receiver can help demodulation of future OFDM symbols. The auto-correlation function (ACF) of the common phase error can be evaluated from the inverse Fourier transform of $L_{\Phi_E}(f)$, corresponding to

$$l_{\Phi_E}(lT) \approx \int_{-\infty}^{\infty} L_{\varphi_N}(f) \cdot \text{sinc}^2(\pi f T) \cdot e^{j2\pi f l T} df. \quad (12)$$

6 Numerical Results

With equation (5) and (6) the ICI power P_{ICI} could be evaluated numerically. For different numbers of sub-carriers N the influence of the phase-noise model parameters a and c on the ICI power is shown in Figs. 4 and 5. The standard deviation of the common phase error σ_{Φ_E} for different numbers of sub-carriers can be seen in Fig. 6. The calculation of the standard deviation of the common phase error was confirmed by simulations. With an increasing number of sub-carriers

corresponding to an increasing OFDM symbol time, σ_{Φ_E} decreases. For optimal tuner design, the maximal allowable ICI power should be set several dB below the channel noise level, otherwise a BER floor will be the result; the technique proposed here can be used in such a trade-off between tuner complexity and performance.

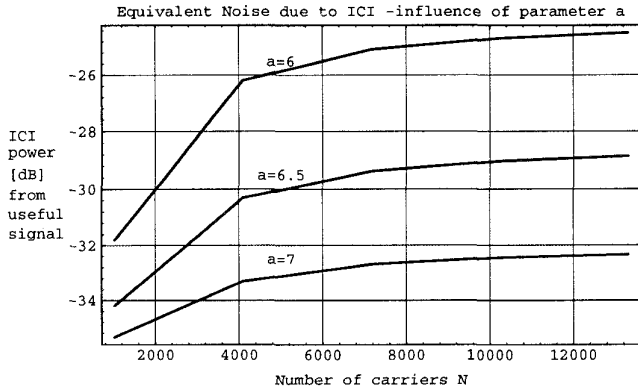

Figure 4: Influence of parameter a on the ICI power, P_{ICI} for $c = 10.5$.

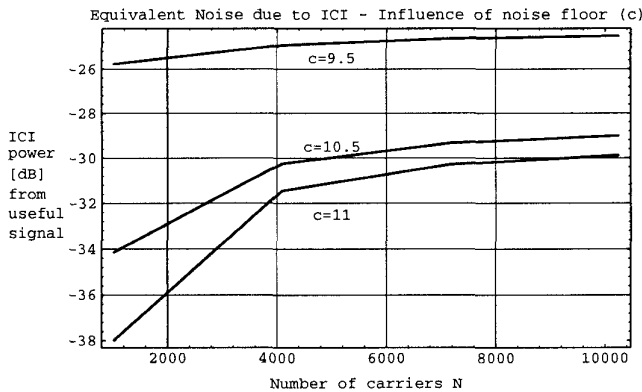

Figure 5: Influence of parameter c on the ICI power, P_{ICI} for $a = 6.5$. If the tuner noise-floor is too high, any high order modulation OFDM system will suffer badly.

The auto-correlation function $l_{\Phi_E}(lT)$ for different FFT sizes is shown in Fig. 7. As expected, only for a decreasing FFT size, which corresponds to a decreasing OFDM symbol duration, the correlation of the common phase error between adjacent OFDM symbols increases. That implies that only for a small number of sub-carriers a feed-back correction of the common phase error before the FFT (i.e. a correction of the next several OFDM symbols see Fig. 9) could be effective.

7 Eliminating the Common Phase Error

As we have seen above, the auto correlation function of the common phase error is small even for shifts of one OFDM

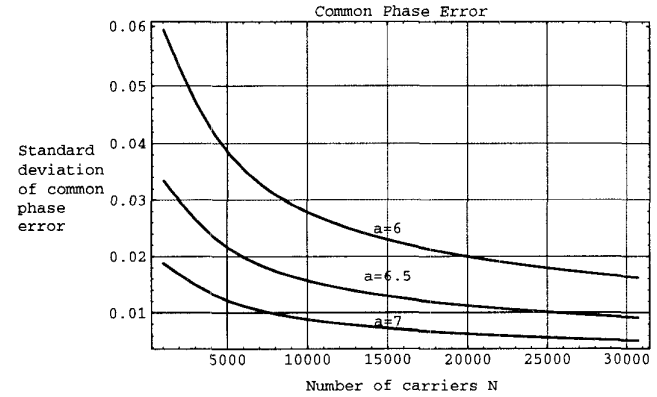

Figure 6: Standard deviation σ_{Φ_E} of common phase error [radians].

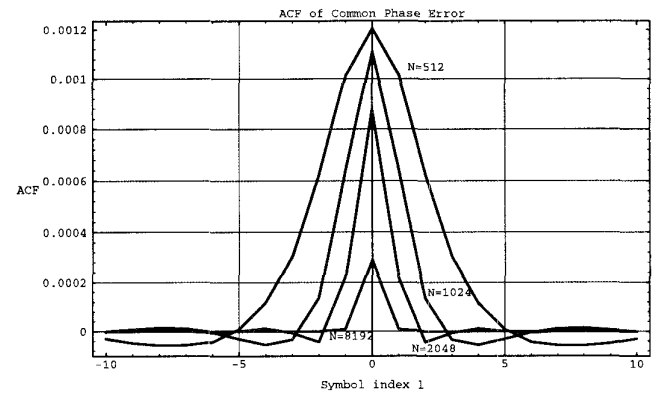

Figure 7: ACF l_{Φ_E} of the common phase error where the parameter is the number of OFDM sub-carriers.

symbol time T when N is large. This means that knowledge of previous values of Φ_E will not help in estimating future values. Fortunately, there exists a simple method of estimating Φ_E and using this estimate to directly correct all the sub-channel in OFDM symbol l in a feed-forward structure, before demodulation and even further processing such as channel estimation.

We can estimate Φ_E if we know the transmitted phase and channel phase of a set of sub-channels with frequency index $c_{i,l}$ where $1 \leq i \leq N_l^s$ and $N_l^s \ll N$ is the number of such sub-channels used in OFDM symbol l -i.e. a symbol variant pattern of known phases. The number and position in frequency (index c) of these sub-channels may be a function of index l . Averaging over the phase error of each such sub-channel yields the estimate

$$\hat{\Phi}_{E,l} = \frac{\sum_{i=1}^{N_l^s} \gamma_{l,c_{i,l}} \cdot \phi_{l,c_{i,l}}}{\sum_{i=1}^{N_l^s} \gamma_{l,c_{i,l}}}, \quad (13)$$

here, $\gamma_{l,c_{i,l}}$ is a reliability estimate -for instance the estimated sub-channel amplitude for sub-channel $c_{i,l}$ at symbol l - and

$\phi_{l,c_{i,l}}$ is the phase difference between the transmitted phase of sub-channel $c_{i,l}$ and the received phase. The transmitted phase can be made known to the receiver by designating sub-channels $c_{i,l}$ for pilot cells with known phase: a possible structure of pilot cells is shown in Fig. 8. Channel estimation can be performed using these pilot cells as well, for instance with Wiener filters as described in [7].

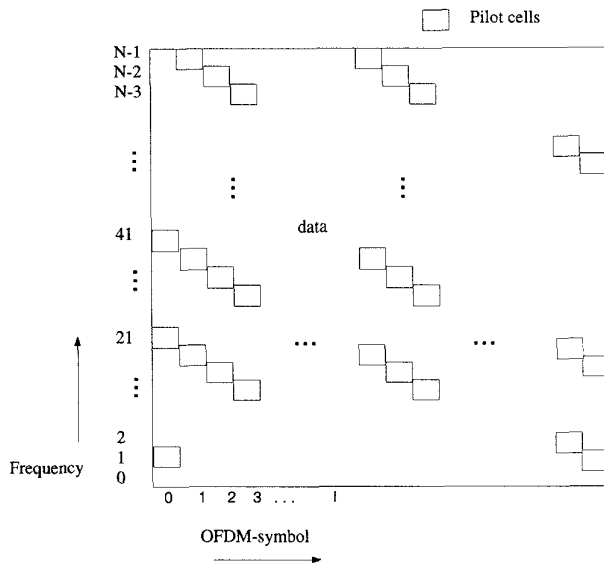

Figure 8: A possible arrangement of pilot cells

The situation is complicated somewhat if the transmission channel introduces a frequency selective phase offset; in this case this phase difference must be estimated and subtracted from $\phi_{l,c_{i,l}}$ too.

An illustration of such a scheme can be seen in Fig. 9. It should be ensured that the channel estimate used to correct $\phi_{l,c_{i,l}}$ is reasonably new and accurate, this enables the input to the channel estimator to be corrected by $\hat{\Phi}_{E_l}$ also. Important is that there are pilot cells in each OFDM symbol, otherwise $\hat{\Phi}_{E_l}$ cannot be estimated. Alternatively, one might envisage data directed techniques instead of pilot symbols, then using the estimate $\hat{\Phi}_{E_l}$ to enhance a second detection process.

7.1 Simulation results

In Fig. 10 the total phase errors $\Psi_E = \Phi_E + \Phi_{ICI}$ of the sub-carriers per OFDM symbol are illustrated for a OFDM system with a 2k FFT. The common phase error of each OFDM symbol can be seen in addition to the phase deviations in one OFDM symbol due to the ICI (Φ_{ICI}). The feed-forward method estimates and corrects this common phase error for each symbol, what remains are the effects of ICI. As expected from Fig. 7 the common phase errors of adjacent OFDM symbols are nearly uncorrelated.

For a system with hierarchical multi-level coding [2] using 64 QAM, suffering from Ricean fading and employing real

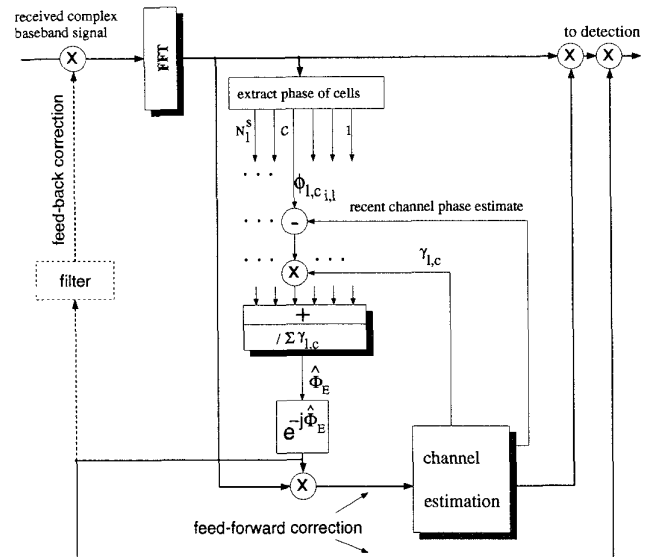

Figure 9: A possible implementation of the feed-forward correction (the dotted lines indicate how a feed-back correction might be implemented). Thick lines denote complex signals.

channel estimation, the power degradations due to phase-noise with and without feed-forward correction of the common phase error for different parameters a are plotted in Fig. 11. The OFDM system again has a 2k FFT and the results are valid for a BER of $4 \cdot 10^{-4}$ (after inner decoding -we assume an outer error correcting/detecting block code). The simulations include real channel estimation with sub-carrier PLL's [8]. It could be seen that if a feed-forward correction of the common phase error is performed, the degradation due to phase-noise is small. Furthermore, by choosing $c \geq 10.5$ and $a \geq 6.3$ there is no visible impact on the residual degradation from ICI for this coding scheme where the channel SNR is about 22 dB; this is in accordance with our numerical results for the ICI.

It must be added that without common phase error correction the error structure (before channel decoding) is bursty, since only comparatively few symbols will suffer from a large common phase error. A coded system (assuming no interleaving across symbols) would suffer severely during the reception of such badly affected symbols.

Finally, the complete BER curve of the above coded OFDM system is shown without phase-noise, with phase-noise and with phase-noise and feed-forward correction of the common phase error in Fig. 12. The good performance with phase-noise and feed-forward correction is evident. Comparing the operating SNR of roughly 22 dB with Figs. 4 and 5, we can conclude that the ICI is insignificant here.

8 Conclusions

Based on a simple phase-noise model, we have presented numerical techniques for calculation of the power of inter-

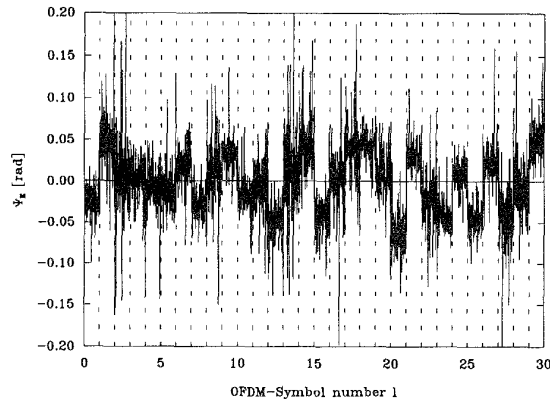

Figure 10: Mixed time/frequency representation of phase-noise: Within each *OFDM symbol* we have plotted the total phase error Ψ_E of each *sub-carrier*.

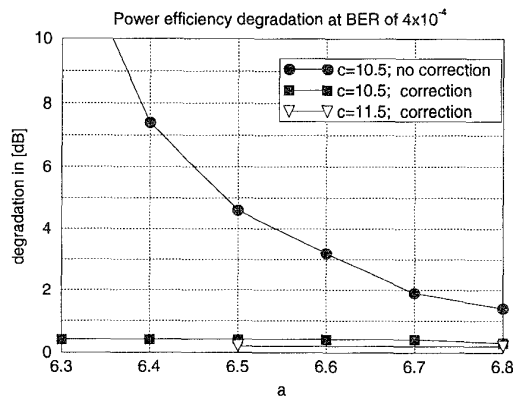

Figure 11: Degradation due to phase noise and the benefits of the feed-forward correction as a function of the phase-noise model parameters.

carrier interference from phase-noise in OFDM schemes. The analysis will allow the design of low cost tuners that just meet the necessary phase-noise requirements and hence ensure satisfactory overall system performance. The most important factor -for a fixed phase-noise model and total system bandwidth- governing the ICI power is the number of OFDM sub-carriers. The ICI level increases as the number of sub-carriers increases, and will pose a serious problem if, for instance, 8k sub-carriers are used in conjunction with high order modulation, such as multi-resolution modulation [9].

Apart from ICI, a common phase error also results in degradation of transmission quality, that becomes less severe with an increasing number of sub-carriers. To combat this common phase error, we proposed a feed-forward correction scheme based on pilot cells, that is simple to implement and very efficient as simulations have confirmed.

Further work could be focussed on defining more refined phase-noise models and their optimization with respect to ICI and tuner complexity.

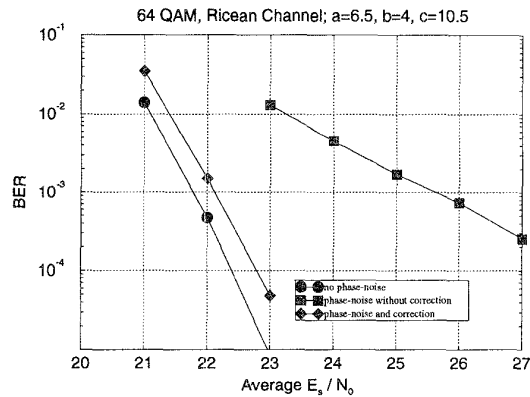

Figure 12: Effects of phase noise on the BER of a typical OFDM system.

Acknowledgements

The authors would like to thank those members within the dTTb and HDTV-T projects involved with coding and modulation for useful discussions.

References

- [1] H. Sari, "Channel equalization and carrier synchronization in OFDM systems," in *Proc. Sixth Tirrenia International Workshop on Communications '93*, September 1993.
- [2] K. Fazel and M. J. Ruf, "A hierarchical digital HDTV transmission scheme for terrestrial broadcasting," in *Proc. GLOBE-COM '93*, December 1993.
- [3] Members of Module 3, "Reducing the effects of phase-noise." Deliverable, Race-dTTb/WP3.33, October 1994.
- [4] V. Kroupa, "Noise properties of PLL systems," *IEEE Trans. Commun.*, vol. 30, pp. 2244-2252, October 1982.
- [5] M. Alard and R. Lassalle, "Principles of modulation and channel coding for digital broadcasting for mobile receivers," *EBU Review*, pp. 47-69, August 1987.
- [6] S. Weinstein and P. M. Ebert, "Data transmission by frequency-division multiplexing using the discrete fourier transform," *IEEE Trans. Commun.*, vol. 19, pp. 628-634, October 1971.
- [7] P. Hoeher, "TCM on frequency-selective land-mobile fading channels," in *Proc. Fifth Tirrenia International Workshop on Communications '92*, pp. 317-328, September 1992.
- [8] K. Fazel, S. Kaiser, P. Robertson, and M. J. Ruf, "A concept of a reconfigurable digital-TV/HDTV transmission scheme with flexible channel coding & modulation for terrestrial broadcasting," in *Proc. International Workshop on HDTV '94*, October 1994.
- [9] T. Cover, "Broadcast channels," *IEEE Trans. IT*, vol. 18, pp. 2-14, January 1972.