

*Engineering*  
*Electrical Engineering fields*

---

Okayama University

Year 1993

---

Analysis of variation of neutral point  
potential in neutral-point-clamped  
voltage source PWM inverters

Satoshi Ogasawara  
Okayama University

Hirofumi Akagi  
Okayama University

This paper is posted at eScholarship@OUDIR : Okayama University Digital Information  
Repository.

[http://escholarship.lib.okayama-u.ac.jp/electrical\\_engineering/14](http://escholarship.lib.okayama-u.ac.jp/electrical_engineering/14)

# Analysis of Variation of Neutral Point Potential in Neutral-Point-Clamped Voltage Source PWM Inverters

Satoshi Ogasawara and Hirofumi Akagi  
 Okayama University  
 3-1-1 Tsushima-Naka  
 Okayama, 700 JAPAN

**Abstract**— This paper describes analysis of the neutral point potential variation of the neutral-point-clamped voltage source PWM inverter (NPC-VSI) for ac motor drives and static var compensators (SVC). The potential variation is analyzed with the focus on the current flowing out of or into the neutral point of the dc link. The theoretical minimum capacity of the dc link capacitors is discussed for its applications to both a vector controlled induction motor system of 2.2kW and a SVC system of 10MVA, 6.6kV, 60Hz.

## I. INTRODUCTION

In recent years, attention has been paid to the “neutral-point-clamped” voltage source PWM inverter (NPC-VSI), which is one of three-level inverters. The NPC-VSI is able to output 5 level-step-shaped line-to-line voltage (3 level-step-shaped phase voltage) without output transformers or reactors, so that it can reduce harmonics in the output voltage and current. Furthermore, the NPC-VSI is suitable to high voltage and high power applications because of series connection of switching power devices. However, the NPC-VSI has such a problem that an excessive high voltage may be applied to switching devices when the floating neutral point potential varies from the center potential of the dc link voltage.

In this paper, the variation of the neutral point potential is analyzed on the basis of an average current flowing out of or into the neutral point. It is shown that the zero sequence voltage of the NPC-VSI output has an important influence upon the potential variation. The principle of the neutral potential control is also described, which

is capable of eliminating or reducing of the variation by controlling the zero sequence voltage. Finally, the theoretically required capacity of the dc link capacitors is estimated for its applications to both a vector controlled induction motor drive and a SVC system.

## II. NEUTRAL-POINT-CLAMPED VOLTAGE SOURCE PWM INVERTER

### A. Configuration of NPC-VSI

Fig.1 shows the main circuit of the NPC-VSI. Table I shows the relationship between switching states of the switching devices and output voltages in one phase. The NPC-VSI has  $3^3=27$  kinds of switching mode, because each phase can output three kinds of voltage as shown in Table I. The NPC-VSI is capable of reducing the output harmonic voltage and current considerably because of 5 level-step-shaped line-to-line voltage (3 level-step-shaped phase voltage) without output transformers or reactors. If the potential of the neutral point is kept at the center potential of the dc link voltage, the applied voltage of each switching device equals half of the dc link voltage. Therefore, the NPC-VSI is suitable to high voltage and high power applications.

### B. Variation of Neutral Point Potential

The NPC-VSI has such a problem that an excessive high voltage may be applied to switching devices when the

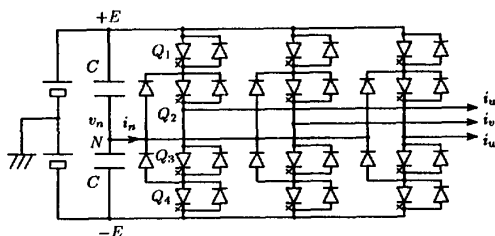

Fig. 1. Main circuit of NPC-VSI.

TABLE I SWITCHING STATES OF NPC-VSI

device	$V_x = +E$	$V_x = N$	$V_x = -E$
$Q_{1x}$	on	off	off
$Q_{2x}$	on	on	off
$Q_{3x}$	off	on	on
$Q_{4x}$	off	off	on
$S_x$	+	N	-

$V_x$ : output phase voltage

$S_x$ : switching function

$x = u, v, w$

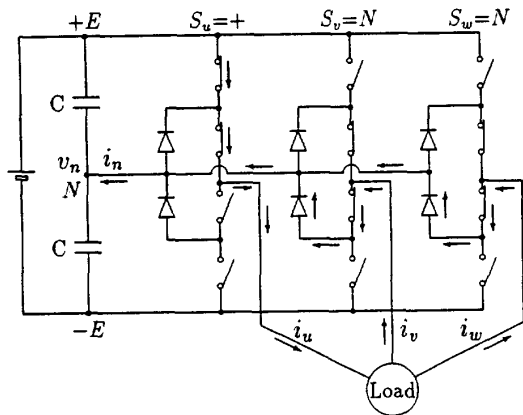

(a) switching mode: [+ N N]

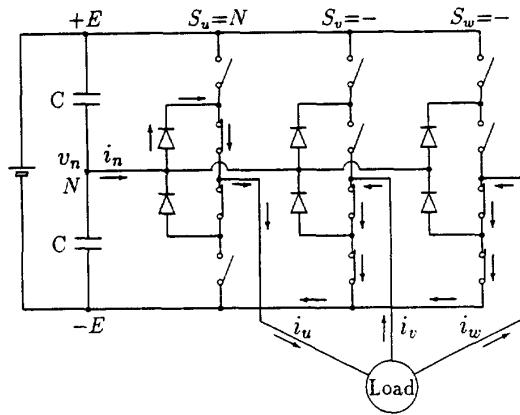

(b) switching mode: [N - -]

Fig. 2. Switching states of main circuit.

floating neutral point potential varies from the center potential of the dc link voltage. Therefore, the neutral point potential should be kept at the center potential of the dc link voltage.

The neutral current flowing out of or into the neutral point of the dc link causes the variation of the neutral point potential of the NPC-VSI. It continues to flow while output phase voltage in any phase equals zero, i.e., the output terminal is clamped to the neutral point. Fig.2 shows two switching states of the main circuit, which are [+ N N] and [N - -]. It is obvious that the line-to-line voltages of the three-phase load are identical in both switching modes. However, the zero sequence output voltages of the NPC-VSI are different each other.

Assume that the  $u$ -phase current is positive and the  $v$ -

and  $w$ -phase currents are negative. The neutral current flows into and out of the floating neutral point in the cases of [+ N N] and [N - -], respectively. Although the NPC-VSI outputs the same voltage vector in both cases, the direction of the neutral current is different, owing to the zero sequence output voltage of the NPC-VSI. This shows that the zero sequence voltage of the NPC-VSI plays an important role in the potential variation.

### III. ANALYSIS METHOD OF NEUTRAL POINT POTENTIAL VARIATION

In the following analysis, it is assumed that the carrier frequency is enough high as compared with the fundamental output frequency of the NPC-VSI. To produce less output harmonics than those of a conventional PWM inverter having 6 switching devices, switching in one phase should be performed between the positive potential of  $+E$  and the neutral potential of  $N$  or between the negative potential of  $-E$  and the neutral potential of  $N$ . Consequently, the NPC-VSI outputs a desired voltage as an average voltage during a carrier period, which is obtained by switching between  $+E$  and  $N$  for a positive voltage or between  $N$  and  $-E$  for a negative voltage. The NPC-VSI adopting the above-mentioned switching scheme produces lower harmonics in the output voltage and current than the conventional PWM inverter does.

Furthermore, it is assumed that the output voltages and currents are sinusoidal as follows:

$$\left. \begin{aligned} v_u &= a \sin \varphi + v_0 \\ v_v &= a \sin \left( \varphi - \frac{2}{3}\pi \right) + v_0 \\ v_w &= a \sin \left( \varphi + \frac{2}{3}\pi \right) + v_0 \end{aligned} \right\} \quad (1)$$

$$\left. \begin{aligned} i_u &= \sqrt{2}I \sin (\varphi - \theta) \\ i_v &= \sqrt{2}I \sin \left( \varphi - \theta - \frac{2}{3}\pi \right) \\ i_w &= \sqrt{2}I \sin \left( \varphi - \theta + \frac{2}{3}\pi \right) \end{aligned} \right\} \quad (2)$$

$$\varphi = \omega \omega_R t \quad (3)$$

Here, three phase voltages and currents, and the angular frequency are expressed by normalizing with respect to the half of the dc link voltage  $E$ , the rated current  $I_R$ , and the rated angular frequency  $\omega_R$ , respectively. The modulation index is expressed by  $a$ , and  $v_0$  means the zero sequence output voltage of the NPC-VSI.

When any phase is clamped to the neutral point, the neutral current flows so that the neutral potential varies from the center potential of the dc link. Fig.3 shows the relationship between an average phase voltage and a time ratio of the neutral-point-clamped phase output. At zero phase voltage, the output terminal of the phase is always

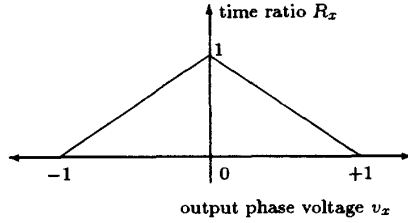

Fig. 3. Output voltage and time ratio.

clamped to the neutral point, so that the time ratio is 1. In proportion as the increase of the absolute value of the phase voltage the time ratio decreases, and it becomes zero at  $\pm E$ . Consequently, the time ratio in each phase is shown by the following equation.

$$R_x = \begin{cases} 1 - v_x & (v_x > 0) \\ 1 & (v_x = 0) \\ 1 + v_x & (v_x < 0) \end{cases} \quad (x = u, v, w) \quad (4)$$

Since a phase current  $i_x$  flows out of the neutral point through its corresponding clamp-diode, the average neutral current in the phase is the product of the phase current  $i_x$  and the time ratio  $R_x$ . Therefore, the average neutral current during a modulation period is given by

$$i_n = R_u i_u + R_v i_v + R_w i_w \quad (5)$$

and the normalized neutral potential variation with respect to the center potential of dc link is easily calculated by the following equation.

$$v_n = -\frac{I_R}{2CE} \int i_n dt \quad (6)$$

The analysis should be performed in six sections shown in Fig.4, because the polarity of the phase voltage alters  $R_x$  ( $x=u, v, w$ ) as shown in (4). In section [I], i.e., in the case that the  $u$ -phase voltage is positive and the  $v$ - and  $w$ -phase voltages are negative, the average neutral current is derived from substitution of (1)-(4) into (5).

$$i_n = a\sqrt{2}I \left\{ \frac{1}{2} \cos \theta + \cos(2\varphi - \theta) \right\} - 2v_0\sqrt{2}I \sin(\varphi - \theta) \quad (7)$$

From (6), the normalized neutral point potential  $v_n$  is calculated by

$$v_n = A \cdot \bar{v}_n \quad (8)$$

$$\bar{v}_n = -\frac{I}{\omega} \left[ \frac{a}{2} \{ \varphi \cos \theta + \sin(2\varphi - \theta) \} + 2v_0 \cos(\varphi - \theta) \right] + \bar{v}_{n0} \quad (9)$$

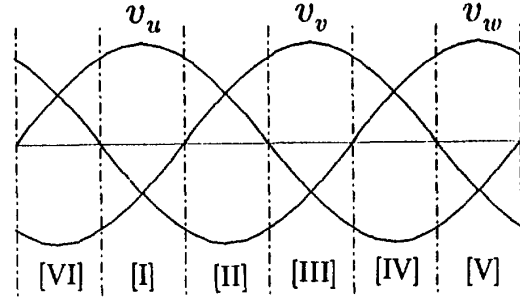

Fig. 4. Division of analysis period.

where,

$$A = \frac{\sqrt{2}I_R}{2\omega_R C E} \quad (10)$$

$\bar{v}_n$  means a generalized neutral point potential irrespectively of the ratings of the NPC-VSI, and  $\bar{v}_{n0}$  is its initial value.

The idea of the generalized neutral point potential can simplify a design of the NPC-VSI. If the generalized neutral point potential is analyzed for a NPC-VSI system, the analysis and design results are applicable to other systems having different ratings.

The neutral current in section [II] is obtained by the similar way to the calculation of (7).

$$i_n = -a\sqrt{2}I \left[ \frac{1}{2} \cos \theta + \cos \left\{ 2 \left( \varphi + \frac{2}{3}\pi \right) - \theta \right\} \right] + 2v_0\sqrt{2}I \sin \left( \varphi + \frac{2}{3}\pi - \theta \right) \quad (11)$$

The following equation shifts the angle of  $\varphi$  by  $\pi/3$ .

$$\varphi = \varphi' + \frac{\pi}{3} \quad (12)$$

Therefore, substituting the above equation into (11) derives as follows:

$$i_n = -a\sqrt{2}I \left\{ \frac{1}{2} \cos \theta + \cos(2\varphi' - \theta) \right\} - 2v_0\sqrt{2}I \sin(\varphi' - \theta) \quad (13)$$

Eqs.(7) and (13) have the same form except for a different sign of the first term on the right hand side. In the sections [III]-[VI], the neutral current is similarly calculated. As a result, quite the same form as that in section [I] or section [II] is obtained in sections [III] and [V] or in sections [IV] and [VI], respectively.

This result indicates as follows: 1) In the case of  $v_0=0$ , the neutral point potential varies at three times as high as the output fundamental frequency, because the sign of the neutral current changes every  $60^\circ$ . 2) The dc component

of the zero sequence voltage moves away the neutral point potential from the center potential of the dc link, because of the second term with the same sign in Eqs.(7) and (13). In this case, an excessive high voltage may be applied to the switching devices of the NPC-VSI. To prevent the problem, it is necessary to eliminate any dc component in the zero sequence output voltage.

#### IV. PRINCIPLE OF NEUTRAL POTENTIAL CONTROL

The variation of the neutral potential can be reduced by an adequate control of the zero sequence output voltage of the NPC-VSI.

In section [I], the neutral current is again shown by

$$i_n = a\sqrt{2}I \left\{ \frac{1}{2} \cos \theta + \cos(2\varphi - \theta) \right\} - 2v_0\sqrt{2}I \sin(\varphi - \theta) \quad (14)$$

If the NPC-VSI outputs such a zero sequence voltage  $v_0^*$  that the neutral current is forced to be zero, i.e.

$$v_0^* = \frac{a \frac{1}{2} \cos \theta + \cos(2\varphi - \theta)}{2 \sin(\varphi - \theta)}, \quad (15)$$

the neutral potential variation can be suppressed completely.

However, each phase voltage is restricted within  $\pm 1$ , i.e.,

$$1 \geq v_x \geq -1 \quad (x = u, v, w) \quad (16)$$

because a NPC-VSI can not output a higher phase voltage than half of the dc link voltage. If any phase is subjected to the restriction, the complete suppression of the neutral potential variation is no longer possible. In the following, analysis is done in the case of  $v_0^* > 0$ . Since the maximum zero sequence voltage  $v_{0\max}$  which the NPC-VSI can output is given by

$$v_{0\max} = \min(1 - v_x) \quad (x = u, v, w), \quad (17)$$

a zero sequence voltage  $v_0'$  which is lacking for complete suppression of the neutral current is as follows:

$$\begin{aligned} v_0' &= v_0^* - v_{0\max} \\ &= \frac{a \frac{1}{2} \cos \theta + \cos(2\varphi - \theta)}{2 \sin(\varphi - \theta)} - v_{0\max} \end{aligned} \quad (18)$$

To reduce the neutral point potential variation, the NPC-VSI outputs the maximum zero sequence voltage within the restriction. In this case, the neutral current  $i_n$  is given by

$$\begin{aligned} i_n &= a\sqrt{2}I \left\{ \frac{1}{2} \cos \theta + \cos(2\varphi - \theta) \right\} \\ &\quad - 2v_0\sqrt{2}I \sin(\varphi - \theta) \\ &\quad + 2v_0'\sqrt{2}I \sin(\varphi - \theta) \end{aligned} \quad (19)$$

The above equation is converted because the sum of the first and second terms on the right hand side equals zero from (15).

$$i_n = 2v_0'\sqrt{2}I \sin(\varphi - \theta) \quad (20)$$

Therefore, the generalized neutral point potential is as follows:

$$\bar{v}_n = \frac{2I}{\omega} v_0' \cos(\varphi - \theta) + \bar{v}_{n0} \quad (21)$$

The neutral point potential varies as shown in the above equation only when any phase is subjected to the restriction of (16).

Similarly, the analysis in section [II] is done in the case that the neutral current  $i_n$  is reduced by controlling the zero sequence voltage. Since the minimum zero sequence voltage  $v_{0\min}$  which the NPC-VSI can output is given by

$$v_{0\min} = \max(1 - v_x) \quad (x = u, v, w), \quad (22)$$

a zero sequence voltage  $v_0'$  which is lacking for complete suppression of the neutral current is as follows:

$$v_0' = -\frac{a \frac{1}{2} \cos \theta + \cos(2\varphi' - \theta)}{2 \sin(\varphi' - \theta)} - v_{0\max} \quad (23)$$

where,

$$\varphi = \varphi' + \frac{1}{3}\pi \quad (24)$$

The neutral current is also calculated.

$$i_n = 2v_0'\sqrt{2}I \sin(\varphi' - \theta) \quad (25)$$

Since  $v_{0\max}$  and  $-v_{0\min}$  have quite the same form due to symmetry, only the sign is different in  $v_0'$  between sections [I] and [II]. Therefore, sections [I] and [II] have the same form in  $i_n$  except for the sign. Quite the same form as that in section [I] or section [II] is obtained in sections [III] and [V] or in sections [IV] and [VI], respectively.

This neutral potential control method proposed here can eliminate the neutral current within the restriction of zero sequence voltage shown in (16). Although the zero sequence voltage is subjected to the restriction, the neutral potential variation can be reduced because the NPC-VSI outputs the maximum zero sequence voltage within the restriction.

#### V. DESIGN OF DC LINK CAPACITOR OF NPC-VSI

It is important in a design of the NPC-VSI to decide the capacity of the dc link capacitors. The neutral point potential variation can be analyzed if the phase angle  $\theta$ , the modulation index  $a$ , the output angular frequency  $\omega$ , and the output current  $I$  are known. The following gives two examples of the design of the dc link capacitor in applications of the NPC-VSI to a vector control system of an induction machine and to a static var compensator.

TABLE II RATINGS OF VECTOR CONTROL SYSTEM

induction machine	2.2kW, 200V, 4P
dc link voltage $2E$	270V
rated current $I_R$	9.2A
rated angular frequency $\omega_R$	$2\pi \times 50$ rad/s

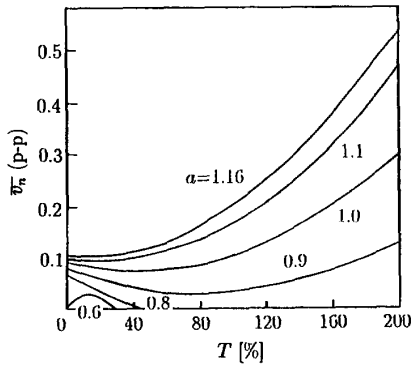

(a) with the neutral point potential control

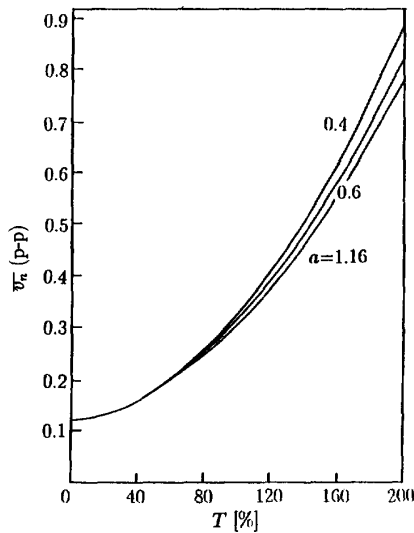

(b) with no control ( $v_0=0$ )

Fig. 5. Generalized neutral potential variation.

#### A. Vector Control System of Induction Machine

Table II shows electrical ratings of a vector control system of an induction machine. In the case of the vector control system, the phase angle  $\theta$ , the angular frequency  $\omega$ , and the output current  $I$  can be calculated if the modulation index  $a$  and the torque are given as the parameters. Here, the magnetizing current being constant at 4A is assumed in the vector control system.

Fig.5 shows relationships between the generalized neutral potential  $\bar{v}_n$  and output torque  $T$  which the vector controlled induction machine produces (a) with the neu-

tral point potential control mentioned above and (b) with no control ( $v_0=0$ ). Here, the generalized neutral potential is evaluated by the peak-to-peak value. In the case of (b), the generalized neutral potential increases with the increase of the torque because of the increase of the output current. The tendency is hardly affected by the modulation index, because the output frequency is approximately in inverse proportion to the modulation index.

In the case of (a), it is shown that the generalized neutral potential is reduced under all conditions, compared with Fig.5(b) owing to the suppression control of the neutral point potential variation. Especially, the generalized neutral potential can be eliminated under the modulation index of 0.8 except for a lower torque region.

For example, it is assumed that the vector control system is used in an operation region up to  $a=1.16$  and  $T=200\%$ , and that the neutral potential variation should be suppressed within  $\pm 1.5\%$ . In this case, the maximum value of the generalized neutral potential variation is less than 0.52. Therefore, the required capacity of the dc link capacitor is calculated by

$$C = \frac{\sqrt{2}I_R \bar{v}_n}{2\omega_R E v_n} \approx 2,700 \text{ } [\mu\text{F}]. \quad (26)$$

The value is approximately equivalent to the dc capacitor which is generally installed in a conventional PWM inverter of 5kVA.

#### B. Static Var Compensator

In case of the application of the NPC-VSI to static var compensators, the current phase angle  $\theta$  of the NPC-VSI is equal to  $\pi/2$ , because almost all loads connected to distribution lines are generally lagging. Fig.6 shows average neutral current waveforms of the NPC-VSI applied to a SVC (a) with the neutral point potential control mentioned above and (b) with no control ( $v_0=0$ ). In the case of (b), the frequency of the neutral current is three times the source frequency and the amplitude is proportional to the modulation index. The peak value of the neutral current is  $\sqrt{6}/2=1.22$  times the rms value of the output current at  $a=1$ . In the case of (a), it is shown that the neutral current is reduced under all conditions, compared with Fig.6(b) owing to the suppression control of the neutral point potential variation. Especially, the neutral current can be eliminated under the modulation index of 0.5.

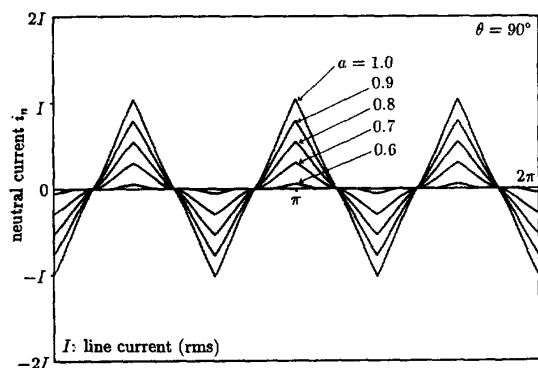

(a) with the neutral point potential control

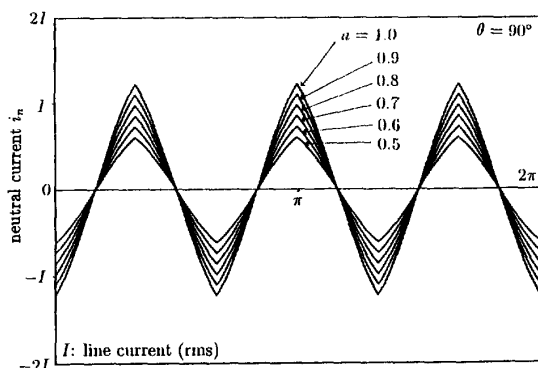

(b) with no control ( $v_0=0$ )

Fig. 6. Average neutral current waveforms.

However, the neutral current increases in the region of the modulation index above 0.6. The peak value of the neutral current is approximately the same as the rms value of the output current at  $a=1$ .

Although the neutral current decreases as the modulation index decreases, the voltage rating of the NPC-VSI increases because of requiring a higher dc link voltage. Here, the theoretical minimum capacity of the dc link capacitors is calculated at  $a=1$  for a SVC system (10MVA, 6.6kV, 60Hz). Table III shows the calculation conditions. Here, it is assumed that the neutral point potential variation has to be suppressed within  $\pm 3\%$  ( $\pm 320V$ ) by introducing the suppression control mentioned above. As a result, the dc link capacitors require the capacity of  $920\mu F$  at least. This capacity is equivalent to that of a dc link capacitor which is required to suppress the dc link voltage variation within 1% when the negative phase sequence component of 2% is included in the line voltages.

TABLE III CALCULATION CONDITIONS

rated capacity	10MVA
rated voltage	6.6kV
rated current	875A
frequency	60Hz
modulation index $a$	1.0
dc link voltage	10.8kV
variation of neutral potential	$\pm 3\%$ (max)
capacity of dc link capacitor $C$	$920\mu F$ (min)

## VI. CONCLUSION

This paper presented the analysis of the neutral point potential variation of the NPC-VSI. An analysis method of the variation was proposed, which is based on the average current flowing at the neutral point of the dc link. A suppression control scheme of the variation was also proposed. The potential variation can be eliminated or reduced by controlling the zero sequence voltage of the NPC-VSI output. The design of dc link capacitor was discussed for both a vector controlled induction motor drive system of 2.2kW and a SVC system of 10MVA. As a result, it is shown that the proposed control scheme makes it possible to suppress the neutral point potential variation within a few percents, so that the total capacity of the dc link capacitors in the NPC-VSI is almost the same as that in the conventional voltage source inverter.

## REFERENCES

- [1] A.Nabae, I.Takahashi and H.Akagi: "A New Neutral-Point-Clamped PWM Inverter", *IEEE Trans. on IA*, Vol. IA-17, No.5, pp.518-523,1981
- [2] J.K.Steinke: "Control Strategy for A Three Phase AC Traction Drive with Three-Level GTO PWM Inverter", *IEEE PESC '88*, pp.431-438, 1988
- [3] B.Velaerts, P.Mathys, E.Takakis and G.Bingen: "A Novel Approach to The Generation And Optimization of Three-Level PWM Wave Forms", *IEEE PESC '88*, pp.1255-1262, 1988
- [4] J.Holtz and L.Springob: "Reduced Harmonics PWM Controlled Line-Side Converter for Electric Drives", *IEEE IAS Annual Meeting*, pp.959-964, 1990
- [5] S.Ogasawara and H.Akagi: "A Vector Control System Using a Neutral-Point-Clamped Voltage Source PWM Inverter", *IEEE IAS Annual Meeting*, pp.422-427, 1991
- [6] Y.Tadros, S.Salama and R.Höf: "Three Level IGBT Inverter", *IEEE PESC '92*, pp.46-52, 1992