

ANGLED JET FLOW MODEL FOR A DIESEL ENGINE INTAKE PROCESS—RANDOM VORTEX METHOD

NAK WON SUNG, JONATHAN A. LAITONE AND DONALD J. PATTERSON

Department of Mechanical Engineering and Applied Mechanics, The University of Michigan, Ann Arbor, Michigan 48109, U.S.A.

SUMMARY

A numerical model is developed to study the interactions of multiple angled jet flows in the inlet port plane of the Detroit Diesel 6V-92 two-stroke engine cylinder. The random vortex method is used in two dimensions.

Results show axisymmetric swirl initially. As flow develops, the centre of the swirl moves to the mid-radius region and begins to precess about the cylinder centre. The flow becomes progressively more chaotic as time progresses.

KEY WORDS Random Vortex Method Model Multiple Jet Flow Two-Stroke Uniflow Diesel Intake Process

INTRODUCTION

The swirling fluid motion inside a two-stroke diesel engine cylinder is important for good mixing of injected fuel with air and for efficient scavenging and combustion. In the Detroit Diesel 6V-92 engine cylinder, the swirl is generated by rectangular inlet ports located at its base. Each of the 18 ports has a 25° entrance angle. The interactions of these multiple jet flows are very complex. While some studies of the swirl and fluid motion inside such a cylinder have been reported,¹⁻³ no work to quantify the flow in the intake port plane by any means has been reported.

The present paper summarizes an analytical attempt to describe the interactions of these multiple jet flows by means of the random vortex numerical fluid modelling method. Figure 1 shows the 6V-92 cylinder with details of a single port. This engine is of the uniflow family with 4 poppet exhaust valves located in the flat cylinder head at the top of the cylinder. At the extreme of the stroke, the piston surface is 13 cm from the cylinder head, just at the lower inlet port edge. It is in this inlet port plane where the study reported herein is focused.

Chorin⁴ developed the random vortex method for two-dimensional flow problems using discrete vortex blobs. In this method grids in the flow field are not required. Also, in this method the boundary layer is simply simulated by the generation of vortices. Hald⁵ showed that this method converges for all time and calculated error bounds by mathematical analysis. Laitone⁶ successfully applied this method to two phase high Reynolds number flow external to a cylinder. Ashurst⁷ used the random vortex method for fluid motion inside a four-stroke engine cylinder with poppet valves during intake and compression periods. He achieved results comparable to those from the finite difference method.⁸

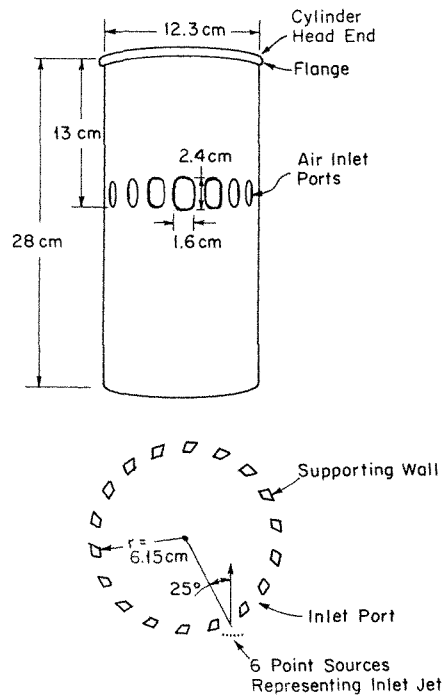

Figure 1. Geometry of the Detroit Diesel 6V-92 engine cylinder and its inlet port plane

NUMERICAL MODEL—RANDOM VORTEX METHOD

Governing equations

Fluid motion is described by the Navier–Stokes equations. From these equations, the two-dimensional time dependent vorticity equation is derived. In non-dimensionalized form, using a characteristic length and velocity, the vorticity equation is,

$$\frac{\partial W}{\partial t} + \mathbf{V} \cdot \nabla W = \frac{1}{\text{Re}} \nabla^2 W. \quad (1)$$

Also, from the definitions of vorticity,

$$W = \frac{\partial U}{\partial y} - \frac{\partial V}{\partial x}, \quad (2)$$

and from the definition of the stream function,

$$U = -\frac{\partial \psi}{\partial y} \quad V = \frac{\partial \psi}{\partial x}, \quad (3)$$

Poisson's equation for the stream function is,

$$\nabla^2 \psi = -W. \quad (4)$$

In the random vortex method, the vorticity of the field is discretized using individual vortex blobs,

$$W = \sum_{i=1}^N W_i. \quad (5)$$

The stream function for each vortex blob is also discretized,

$$\psi = \sum_{i=1}^N \psi_i. \quad (6)$$

The movement of a vortex blob is found as the sum of the convectonal and the diffusional parts. For the convectonal movement, the left side of the vorticity transport equation, equation (1), was solved,

$$\frac{DW}{Dt} = 0. \quad (7)$$

In Lagrangian mechanics, this equation has a solution,

$$W = \text{constant}. \quad (8)$$

For the discretized variables, equation (2) becomes,

$$\nabla^2 \psi_i = -W_i. \quad (9)$$

Equation (9) has a solution of Green's function,

$$\psi_j = \frac{\Gamma_j}{2\pi} \log |r - r_j| \quad (10)$$

where,

$$\Gamma_j = \int W_j \, dx \, dy \quad (11)$$

and $|r - r_j|$ denotes the length of vector $(r - r_j)$. The solution of equation (9) implies that distant blobs affect each other as if they were point vortices of strength W_j as in a potential flow. The solution, equation (10), represents the stream lines in the field generated by the vortex blobs. The vortex blobs move along these stream lines. To satisfy the bounded velocity field near the vortex centre, it was assumed that the stream function was bounded in this region. Thus,

$$\psi = \sum_{i=1}^N \Gamma_i \psi^0(r - r_i) \quad (12)$$

where $\psi^0(r)$ is a fixed function of r such that

$$\psi^0(r) = \begin{cases} \log r/(2\pi) & \text{for } r \geq \sigma \\ r/(2\pi) & \text{for } r < \sigma. \end{cases} \quad (13)$$

For the diffusional movement of the vortex blobs, the portion of equation (1) governing diffusion was solved,

$$\frac{\partial W}{\partial t} = \frac{1}{\text{Re}} \nabla^2 W. \quad (14)$$

This equation also has a solution of Green's function for the one-dimensional case,

$$W(y, t) = \{\text{Re}/(4\pi t)\}^{1/2} \exp \{-y^2 \text{Re}/(4t)\}. \quad (15)$$

This solution may also be obtained by the random walk method of Einstein⁹ as follows. At time t , if N balls are placed on the plane ($y = 0$) and they are allowed to walk once under the conditions that the variance of the walks is $2t/\text{Re}$ and the mean of walks is zero, then the probability of the number of balls at the location between y and $y + dy$ is, from Chorin and Marsden,¹⁰

$$\lim_{N \rightarrow \infty} \frac{\text{number of balls between } y \text{ and } y + dy \text{ at time } t}{N dy} = \{\text{Re}/(4\pi t)\} \exp\{-y^2 \text{Re}/(4t)\}, \quad (16)$$

which is identical to equation (15).

Following the work of Chorin,⁴ the solution of equation (14) in two space dimensions was found from the two-dimensional random walk method. This was done by allowing the balls to walk in a two-dimensional plane.

The locations of the vortex blobs are determined by superimposing the diffusional movement from the random walk method on the convective movement along the stream lines, equation (12). The velocity fields are then calculated from the strengths and locations of vortex blobs.

Procedures

The volumetric flowrate for this study was taken to be $6.33 \text{ m}^3/\text{min}$. This flowrate corresponded to 80 per cent of that for one cylinder of the 6V-92 engine at 1200 rpm and no load.¹¹ This was a condition selected to be consistent with planned experiments on this engine at the University of Michigan Automotive Laboratory. A mean jet velocity of 15.6 m/sec was calculated by dividing this volumetric flowrate into the total inlet open area. Using this mean jet velocity and the cylinder radius of 6.15 cm , all variables were non-dimensionalized.

Potential flow rate was used to simulate inlet jets and the wall boundary. For two-dimensional potential flow, velocity components in Cartesian co-ordinates are,

$$U = -\frac{\partial \psi}{\partial y} \quad V = \frac{\partial \psi}{\partial x}, \quad (3)$$

where ψ is the stream function. Substituting the above equation into the continuity equation yields the Laplace equation for the stream function,

$$\nabla^2 \psi = 0 \quad (17)$$

One simple solution of the above Laplace equation is found from the stream function for a point source of mass,

$$\psi = \frac{Q}{2\pi} \tan^{-1} \left(\frac{y - y_i}{x - x_i} \right), \quad (18)$$

where Q is the strength of the point source and (x_i, y_i) is its location. To simulate the fluid jets arising from the 18 inlet ports with their 25° inlet angles, six identical point sources were distributed outside each inlet port as shown in Figure 1. The source strength was calculated using the 15.6 m/sec mean velocity. The stream line in the velocity field due to each point

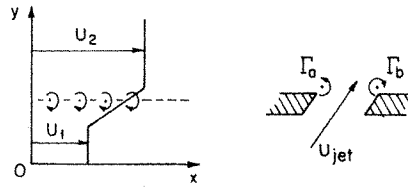

Figure 2. Vorticity flux generation

source was calculated as,

$$\psi = \frac{Q_j}{2\pi} \tan^{-1} \left(\frac{y - y_j}{x - x_j} \right), \quad (19)$$

where Q_j is the strength of a point source for inlet jets and (x_j, y_j) is its location. The wall was constructed using 18 panels similar to Laitone.⁶ Each panel had a point source at the middle. The strength of the point source on each panel was calculated to give zero normal velocity there. This was,

$$\psi = \frac{Q_p}{2\pi} \tan^{-1} \left(\frac{y - y_p}{x - x_p} \right), \quad (20)$$

where Q_p is the strength of a point source for boundary panels and (x_p, y_p) is its location.

After prescribing the inlet jets and wall boundary in the above manner, the inlet port vorticity was generated from the discrete vortex blobs by the method of Ashurst.⁷ In that method and referring to Figure 2, the vorticity flux in a shear layer for a unidirectional velocity change was calculated as

$$\Gamma/\Delta t = \int_1^2 WU \, dy$$

where the vorticity is $W = \partial U/\partial y$. This flux which is independent of the shear layer thickness and velocity profile is:

$$\int_1^2 WU \, dy = \int_1^2 (\partial U/\partial y)U \, dy = \int_1^2 U \, dU = (U_2^2 - U_1^2)/2 \quad (21)$$

Referring to Figure 2, two vortex blobs are generated at each port. Together their strength is,

$$\begin{aligned} \Gamma_a &= -U_{jet}^2 \Delta t/2 \\ \Gamma_b &= +U_{jet}^2 \Delta t/2. \end{aligned} \quad (22)$$

In this study the vorticity generation from the solid wall shear layer was assumed negligible compared to that from the inlet ports. The stream function due to the vortex blobs is then,

$$\psi = \frac{\Gamma}{2\pi} \log r \quad (23)$$

In the first time step, the strengths of the boundary panel sources were calculated to give zero velocity there. Then two vortex blobs were generated at each inlet port. These vortex blobs moved along the stream lines. The stream lines were determined by inlet jet point

sources, boundary panel point sources and vortex blobs. The velocity vector of each vortex blob at (x_B, y_B) was calculated from the stream function derivatives, equation (3),

$$\begin{aligned} U_B &= \sum_{i=1 \neq B}^N \frac{\Gamma_i}{2\pi} \frac{y_i - y_B}{(x_i - x_B)^2 + (y_i - y_B)^2} \\ &\quad + \sum_{j=1}^M \frac{Q_{J,j}}{2\pi} \frac{(x_j - x_B)}{(x_j - x_B)^2 + (y_j - y_B)^2} + \sum_{k=1}^L \frac{Q_{p,k}}{2\pi} \frac{x_k - x_B}{(x_k - x_B)^2 + (y_k - y_B)^2} \\ V_B &= \sum_{i=1 \neq B}^N \frac{\Gamma_i}{2\pi} \frac{x_i - x_B}{(x_i - x_B)^2 + (y_i - y_B)^2} \\ &\quad + \sum_{j=1}^M \frac{Q_{J,j}}{2\pi} \frac{(y_j - y_B)}{(x_j - x_B)^2 + (y_j - y_B)^2} + \sum_{k=1}^L \frac{Q_{p,k}}{2\pi} \frac{y_k - y_B}{(x_k - x_B)^2 + (y_k - y_B)^2} \end{aligned} \quad (24)$$

Here (x_i, y_i) , (x_j, y_j) and (x_k, y_k) are the locations of other vortex blobs, inlet jet point sources and boundary panel point sources respectively.

Using a first order difference equation for integration and taking into account the random walk, the new location of a vortex blob after the first time step was found as,

$$\begin{aligned} x_B^2 &= x_B^1 + U_B \Delta t + n_1 \\ y_B^2 &= y_B^1 + V_B \Delta t + n_2 \end{aligned} \quad (25)$$

where n_1 and n_2 are the random walks.

When two opposite vortex blobs approach each other closer than a prescribed cut-off distance, σ , they were taken to be mutually destroyed. This arose periodically in the course of the random walk process. Also when vortex blobs moved across the wall boundary, they were eliminated. After finding the new locations of the remaining vortex blobs, the velocities in the fields at (x, y) were calculated from the derivatives of the stream function, equation (3),

$$\begin{aligned} U &= \sum_{i=1}^N \frac{\Gamma_i}{2\pi} \frac{y - y_i}{(x - x_i)^2 + (y - y_i)^2} + \sum_{j=1}^M \frac{Q_{J,j}}{2\pi} \frac{x - x_j}{(x - x_j)^2 + (y - y_j)^2} \\ &\quad + \sum_{k=1}^L \frac{Q_{p,k}}{2\pi} \frac{x - x_k}{(x - x_k)^2 + (y - y_k)^2} \\ V &= \sum_{i=1}^N \frac{\Gamma_i}{2\pi} \frac{x - x_i}{(x - x_i)^2 + (y - y_i)^2} + \sum_{j=1}^M \frac{Q_{J,j}}{2\pi} \frac{y - y_j}{(x - x_j)^2 + (y - y_j)^2} \\ &\quad + \sum_{k=1}^L \frac{Q_{p,k}}{2\pi} \frac{y - y_k}{(x - x_k)^2 + (y - y_k)^2}. \end{aligned} \quad (26)$$

In the second time step, the strengths of boundary panel sources were first recalculated to give zero velocities there. Then the velocity vectors of the vortex blobs, the new locations of remaining vortex blobs and the velocities in the fields were calculated following the same procedures described above. To save computer time, the calculation of velocities in the fields was made at discrete time steps. The non-dimensional time increment chosen was 0.2, which was equivalent to 0.8 msec. This followed the approach of Chorin.⁴ To get the two-dimensional flowrate for the inlet plane, the volumetric flowrate was divided by the height of the inlet port, 2.4 cm. The area of inlet port plane (14.4 cm²) was divided by this two-dimensional flowrate to get the characteristic time required for filling up the plane. This was 8 msec. The Reynolds number for this flow was based on the mean jet velocity and the radius

of the cylinder. This value was 69,000. In non-dimensional units, the cut-off distance for mutual destruction of vortex blobs was 0.0025. This was equivalent to 0.16 mm. Calculations for 200 time steps used 300 sec on the University of Michigan Amdahl 470V/6 computer.

Estimate of error

As far as the determination of inertial effects was concerned, the random walks, n_1 and n_2 , could be viewed as harmless perturbations. The standard deviation of random walks was $(2t/Re)^{1/2}$. After N time steps, the total effect of the random perturbations was to induce a displacement error of order

$$(N \cdot 2t/Re)^{1/2} = O(Re^{-1/2}), \tag{27}$$

in the location of vortex blobs. Also, Euler's integration method, equation (25), induced a truncation error of order of magnitude, $O(\Delta t^2)$. Combining these two, the mean error for the location of vortex blobs after N time steps has been assessed as,

$$O(\Delta t^2) + O(Re^{-1/2}) = O(0.04) + O(0.004) \approx O(0.04) \tag{28}$$

RESULTS AND DISCUSSIONS

In Figure 3, path lines of the vortex blobs are shown during the initial 24 msec. Most of the vortex blobs which represent the inlet jet streams are destroyed after a few time steps. In Figure 4, the velocity field is shown after 5 time steps (4 msec). One of the 18 inlet jets is

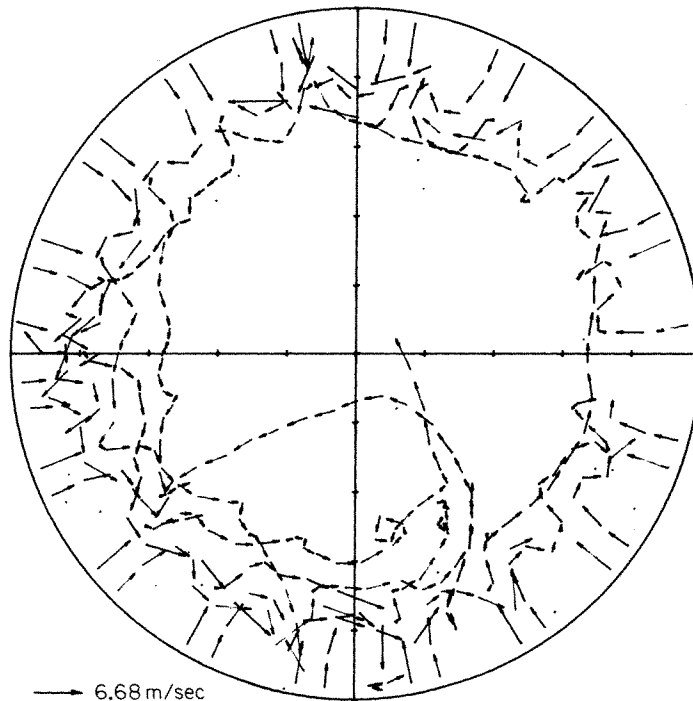

Figure 3. Path lines of vortex blobs. Most of the vortex blobs were mutually destroyed after 5 time steps (4 msec)

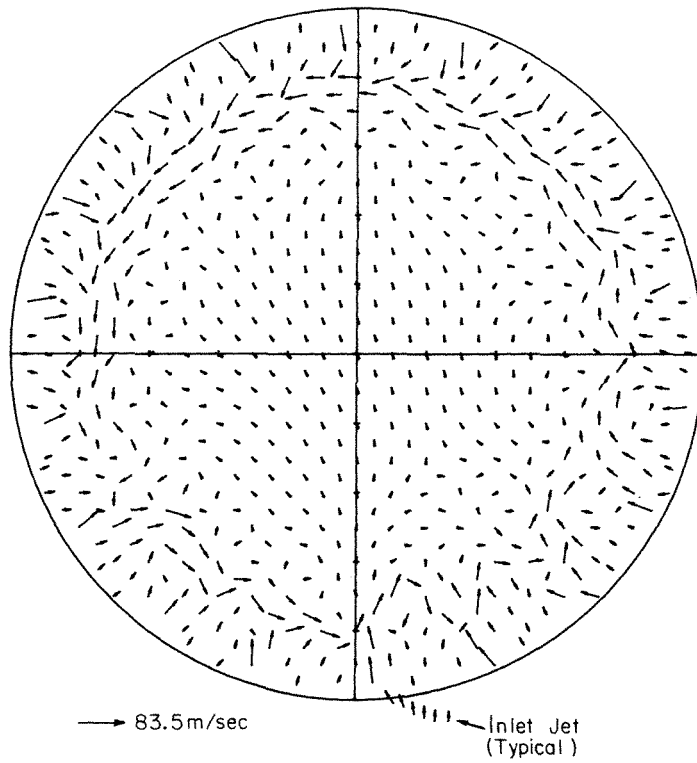

Figure 4. Velocity fields after 5 time steps (4 msec). Flow pattern shows swirl in the inlet jet direction. Each of 18 inlet port jets is simulated by 6 point sources

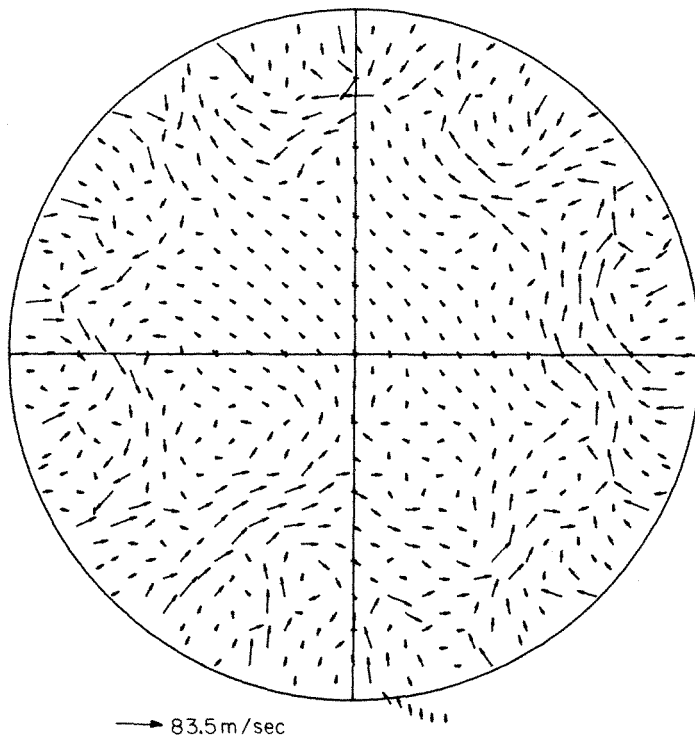

Figure 5. Velocity fields after 15 time steps (12 msec). The swirl begins to oscillate

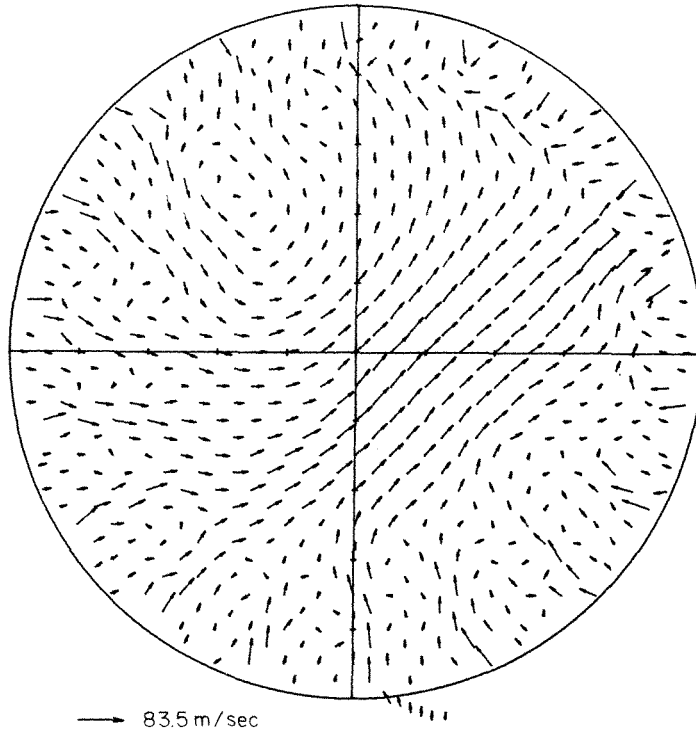

Figure 6. Velocity fields after 30 time steps (24 msec). The flow pattern has become distinctly asymmetric

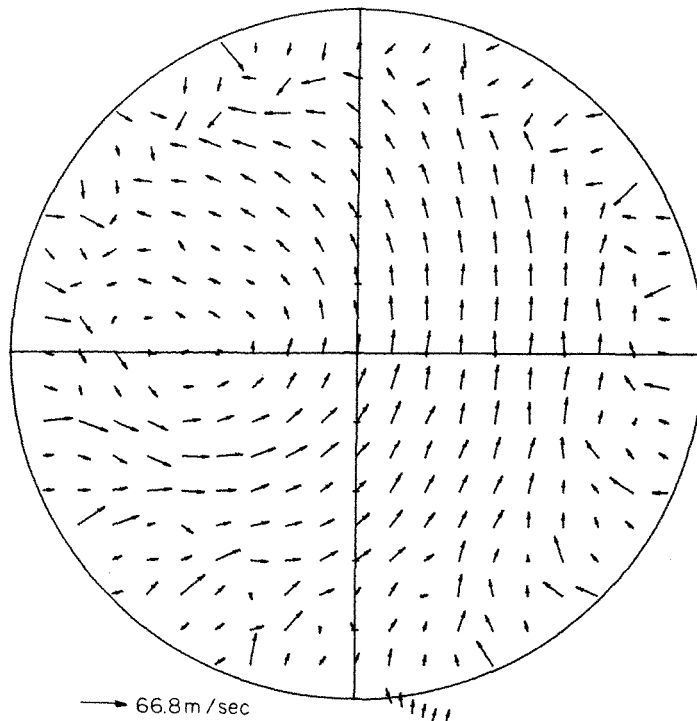

Figure 7. Average velocity fields between 141 and 150 time steps (120 msec). The flow is asymmetric and unsteady

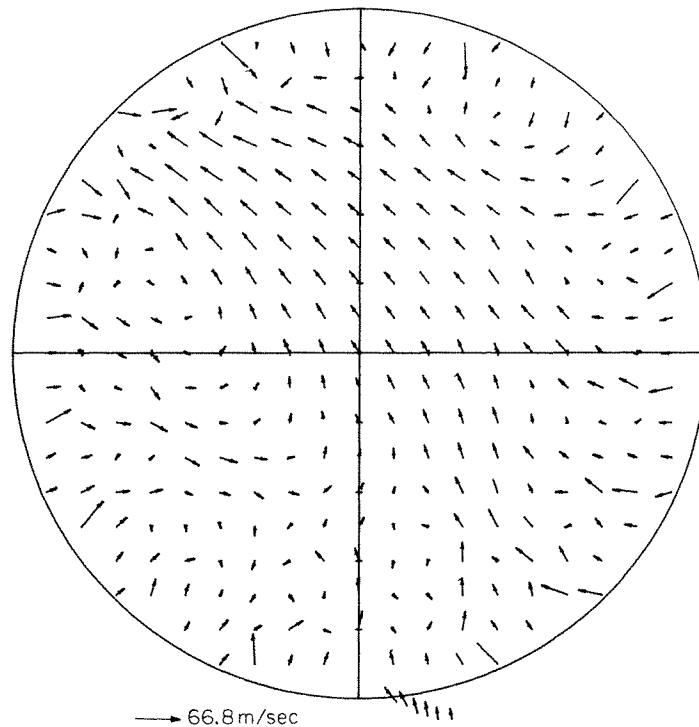

Figure 8. Average velocity fields between 191 and 200 time steps (160 msec). The flow is asymmetric and unsteady

also shown. The length of each arrow is proportional to the velocity magnitude. At this time step, the main swirl was already established in the direction of the inlet jets. The swirl began to oscillate after 15 time steps (12 msec) as shown in Figure 5. At time step 30 (24 msec), Figure 6, asymmetric swirl arose composed of primary and secondary swirl. The average velocity fields for the 10 time steps from 141 to 150 (120 msec) and 191 to 200 (160 msec) are shown in Figures 7 and 8 respectively. They show asymmetric and very unsteady flows.

CONCLUDING REMARKS

A two-dimensional model for multiple planar jet flow has been developed by the random vortex method. In simulating the entrance plane flow in the 6V-92 engine cylinder, this model showed axisymmetric swirl initially. As the flow developed, the centre of the swirl moved to the mid-radius region and began to precess about the cylinder centre. The flow became progressively more chaotic as time progressed.

Since the scavenging period of this engine is about 12 msec at 1200 rpm, these results suggest that the gas exchange process in the cylinder is occurring under highly transient conditions. While experimental verification of these results is needed, our tentative conclusion is that steady state bench tests may not provide the accurate picture of scavenging and swirl characteristics needed for engine development purposes.

This study was an initial attempt to analyse angled jet flow and the resulting swirl. It is a first step in quantifying how entrance port design affects fluid motion in the 6V-92 engine cylinder.

ACKNOWLEDGEMENT

The first and third authors acknowledge the important contributions of the late Professor Jonathan A. Laitone whose untimely death put an end to a promising career.

APPENDIX

Nomenclature

L, M, N	Number of samples and point sources
Q	Strength of a point source
n_1, n_2	Random walk
r	Radius
Re	Reynolds number
t	Time
V	Velocity, (U, V)
W	Vorticity
ψ	Stream function
Γ	Strength of vorticity
σ	Cut-off distance

Subscripts

B	Vortex blob
j, jet	Inlet jet
p	Boundary panel

REFERENCES

1. R. L. Boyer, D. R. Craig and C. D. Miller, 'A photographic study of events in a 14 inch two-cycle gas engine cylinder', *ASME Trans.*, **76**, p. 97 (1954).
2. W. H. Percival, 'Method of Scavenging Analysis for 2-Stroke-Cycle Diesel Cylinders', *SAE Trans.* **63**, p. 737 (1955).
3. P. H. Schweitzer, *Scavenging of Two-Stroke Cycle Diesel Engines*, MacMillan, New York, 1949.
4. A. Chorin, 'Numerical study of slightly viscous flow', *J. Fluid Mechanics*, **57**, 785-796 (1973).
5. O. H. Hald, 'Convergence of vortex methods for Euler's equation. II', *SIAM J. Numer. Anal.*, **16**, No. 5, Oct. (1979).
6. J. A. Laitone, 'Separation effects in gas-particle flows at high Reynolds numbers', *Ph.D. Thesis*, University of California, Berkeley, 1979.
7. W. T. Ashurst, 'Vortex dynamic calculation of fluid motion in a four stroke piston "cylinder"—planar and axisymmetric geometry', *Sandia Laboratories Livermore Report, SAND 78-8229* (1978).
8. R. Diwaker, 'Interaction of combustion with the aerodynamic flow field in an internal combustion reciprocating engine—a two dimensional numerical solution', *Ph.D. Thesis*, University of Maryland, July, 1977.
9. A. Einstein, 'Eine neu bestimmung der molekuldimensionen', *Annalen der Physik*, **19**, 289-306 (1906).
10. A. J. Chorin and J. E. Marsden, *A Mathematical Introduction to Fluid Mechanics*, Springer Verlag, 1979, p. 114.
11. *Engine Service Manual for Series 92*, Detroit Diesel Allison Division, G. M., Detroit, 1979.