



Title	Application of a sinusoidal internal model to current control of three-phase utility-interface converters
Author(s)	Fukuda, S.; Imamura, R.
Citation	IEEE Transactions on Industrial Electronics, 52(2), 420-426 https://doi.org/10.1109/TIE.2005.843914
Issue Date	2005-04
Doc URL	http://hdl.handle.net/2115/5720
Rights	©2005 IEEE. Personal use of this material is permitted. However, permission to reprint/republish this material for advertising or promotional purposes or for creating new collective works for resale or redistribution to servers or lists, or to reuse any copyrighted component of this work in other works must be obtained from the IEEE. " IEEE, IEEE Transactions on Industrial Electronics , 52, 2, 2005, p420-426
Type	article
File Information	ITIE52-2.pdf



[Instructions for use](#)

Application of a Sinusoidal Internal Model to Current Control of Three-Phase Utility-Interface Converters

Shoji Fukuda, *Senior Member, IEEE*, and Ryota Imamura

Abstract—Three-phase voltage-source converters are used as utility interfaces. In such a case, the converter line currents are required to track sinusoidal references synchronized with the utility grid without a steady-state error. In this paper a current control method based on a sinusoidal internal model is employed. The method uses a sine transfer function with a specified resonant frequency, which is called an S regulator. The combination of a conventional proportional–integral (PI) regulator and an S regulator is called a PIS regulator. The PIS regulator ensures that the steady-state error in response to any step changes in a reference signal at the resonant frequency and 0 Hz reduces to zero. An experiment was carried out using a 1-kVA prototype of three utility-interface converters, a voltage-source rectifier, an active power filter, and static synchronous compensator. Almost perfect current-tracking performance could be observed.

Index Terms—Active filter, sinusoidal internal model, static synchronous compensator (STATCOM), voltage-source pulsewidth-modulation (PWM) converter.

I. INTRODUCTION

DEVELOPMENT of renewable and clean energy sources such as photovoltaic, wind, and fuel cells, is growing. Since the majority of such sources generate a dc voltage, a voltage-source pulsewidth-modulation (PWM) inverter and its control technique are essential to connect them to the utility grid [1].

The focus on power quality has been increased with the increased use of power electronic equipment. Harmonic current and reactive current are two of the parameters that characterize the power quality. An active filter and a static synchronous compensator (STATCOM) are expected to be candidates to improve the power quality [2].

In those cases, a three-phase voltage-source PWM inverter/rectifier plays an important role as a power electronic interface to the utility grid. The ac current of the converter is required to be harmonic free and to track rapidly a sinusoidal reference without a steady-state error. In this situation, the following three current-regulating techniques have been used [3], [4]:

- 1) hysteresis control;
- 2) predictive control;
- 3) ramp comparison.

Hysteresis control has the attraction of simplicity, but leads to a widely varying switching frequency. This limitation has been improved with variable hysteresis band switching strategies but it requires a complex controller to achieve satisfactory performance [5]. Predictive current control offers the best potential for precise current control, but implementation of a practical system can be difficult and complex [6].

Ramp comparison control using a proportional-integral (PI) regulator has a long history of use, but has the disadvantage of a steady-state error between the reference current and the output current if the reference is a sinusoidal signal.

This drawback can be solved if the current control is executed in a synchronous d - q coordinate reference frame [3]. A synchronous d - q reference frame is appropriate since the steady-state currents are dc currents and a simple PI regulator will result in zero steady-state error. However, it is more complex and requires more hardware or software for implementation because of the requirement to transfer the measured currents to a synchronous frame and, subsequently, transform the output of the PI regulator back to a stationary frame to drive the ramp comparison controller.

In contrast to the synchronous reference frame control, stationary reference frame control based on the internal model principle from control theory was proposed and was applied to a single-phase active filter [7]. In this paper, a sinusoidal internal model is employed to control a three-phase voltage-source PWM converter for three different utility-interface applications:

- active power filter (AF);
- PWM voltage-source boost rectifier (VSR);
- static synchronous compensator (STATCOM).

The sinusoidal internal model requires a transfer function of a sine wave in the regulator, and it is called an S regulator. In this paper, the validity of an S regulator for the control of utility interface converters is demonstrated by experimental results. No coordinate transformation is required and no steady-state error remains if a PI and S regulator is used.

II. PIS REGULATOR

Consider feedback control of a PWM inverter output current. If $G_{Inv}(s)$, $G_{Load}(s)$, and $G_C(s)$ represent the transfer functions of the PWM inverter, load, and current regulator,

Manuscript received November 28, 2003; revised March 10, 2004. Abstract published on the Internet January 13, 2005. This paper was presented at the IEEE Power Electronics Specialists Conference, Acapulco, Mexico, June 15–19, 2003.

S. Fukuda is with the Graduate School of Information Science and Technology, Hokkaido University, Sapporo 060-0814, Japan (e-mail: fukus@ssi.ist.hokudai.ac.jp).

R. Imamura is with the Patent Department 1, IP Development and Management Division, Intellectual Property Group, Hitachi Ltd., Hitachi 317-0073, Japan.

Digital Object Identifier 10.1109/TIE.2005.843914

respectively, the inverter output current i_C with i_C^* being a current reference will be given by

$$i_C = \frac{G_C G_{\text{Inv}} G_{\text{Load}}}{1 + G_C G_{\text{Inv}} G_{\text{Load}}} i_C^*. \quad (1)$$

A PI and S regulator is defined as a regulator consisting of a proportional (P) action, an integral (I) action, and a transfer function of a sine wave (S action), and is, hereafter, called a PIS regulator.

The transfer function of the PIS regulator will be given by

$$G_C(s) = K_p + \frac{K_i}{s} + \frac{K_s s}{s^2 + \omega_0^2} \quad (2)$$

where ω_0 denotes the resonant frequency of the sine transfer function, and K_p , K_i , and K_s represent the respective gains. The resonant frequency ω_0 is designed to coincide with the frequency of a sinusoidal reference input i_C^* . If the PIS regulator is used, (1) indicates that the gain of the open-loop transfer function, $G_C(s)G_{\text{Inv}}(s)G_{\text{Load}}(s)$, increases to infinity at the frequency ω_0 and 0 Hz. This ensures that the steady-state error $i_C^* - i_C$ in response to a step command change at those frequencies will reduce to zero as far as the system is stable. Furthermore, the PIS regulator will remove the effect of a disturbance at those frequencies. Experimental results in the following three sections demonstrate the usefulness of the PIS regulator.

If the reference i_C^* does not include a dc component as the case of a utility interface converters, an integral regulator may be omitted, and a PIS regulator degenerates to a PS regulator.

A. Design of PS Regulator

The open loop transfer function of an inverter output current control system with an L - R load will be given by

$$G(s) = \left(K_p + \frac{K_s s}{s^2 + \omega_0^2} \right) G_{\text{Inv}}(s) \frac{1}{R + Ls}. \quad (3)$$

The Bode diagram of (3) with only a P regulator ($K_s = 0$) and with a PS regulator are compared in Fig. 1, where the transfer function of the inverter is assumed to be unity, $G_{\text{Inv}}(s) = 1$. The load consists of $R = 8.8 \Omega$ and $L = 49.5$ mH, and the resonant frequency is $\omega_0 = 100\pi \cong 314$ rad/s. The gains are $K_p = 100$ V/A and $K_s = 10\,000$ V/A·s. One can observe that the influence of the S regulator is confined to the area near the resonant frequency and, thus, the P regulator determines major dynamic characteristics. Accordingly, the dynamic performance of the inverter will be governed by the P regulator gain K_p .

PS regulators exhibit excellent control performance for a sinusoidal reference, but there is no general rule to design their respective gains such as Ziegler–Nichols rules for PI regulators. Thus, the gain design is based on the rule of trial and error.

The following is a manner to design the gains that the authors obtained empirically through their experiment. The P gain is determined first, and the S gain is determined last.

- 1) Find the range of the proportional gain K_p with which the phase margin and gain margin of (3) are between 40° – 60°

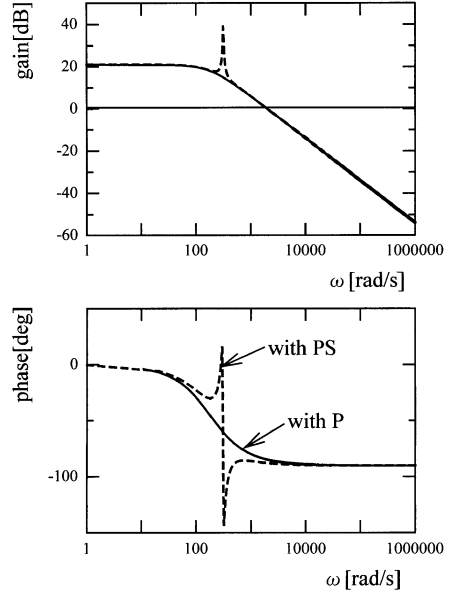

Fig. 1. Bode diagram of the current control system.

and 10–20 dB, respectively [8], considering a stable and rapid response.

- 2) Conduct an experiment on responses to a step change in the current reference using several different K_p 's within the range obtained at the first step. The authors recommend that the currents are transformed to a synchronous d - q reference frame, which allows one an easier evaluation of the responses because the steady-state currents are dc currents.
- 3) Such experimental investigation indicates that if K_p is small the responses are slow as shown in Fig. 2(a). If K_p is too large the responses are rapid but the control reacts to noises as shown in Fig. 2(b). Thus, the authors select the largest K_p with which the control does not react to noises.
- 4) Conduct an experiment on responses to a step change in the reference current using the selected K_p . If K_s is small the responses are slow as shown in Fig. 2(c), and if K_s is too large the responses are rapid but the output overshoots the reference as shown in Fig. 2(d). The authors select the largest K_s with which the output does not overshoot the reference. The step responses with the selected gains are shown in Fig. 2(e).

The gains selected in this manner have an approximate relation $K_s = 100K_p$. This relation is not general, but held even in the three different utility-interface applications described later, VSR, AF, and STATCOM with a sampling frequency of 10 kHz. This fact is helpful in designing the best gain values of PS regulators.

If experiment-based examinations described above are not possible, simulation-based examinations according to the same steps mentioned above are also useful. From the authors' experience, simulation-based examinations provide fairly close gain values to optimal ones, but it should be noted that in most cases they provide optimistic results, that is, larger gains than optimal which the experimental examinations provide.

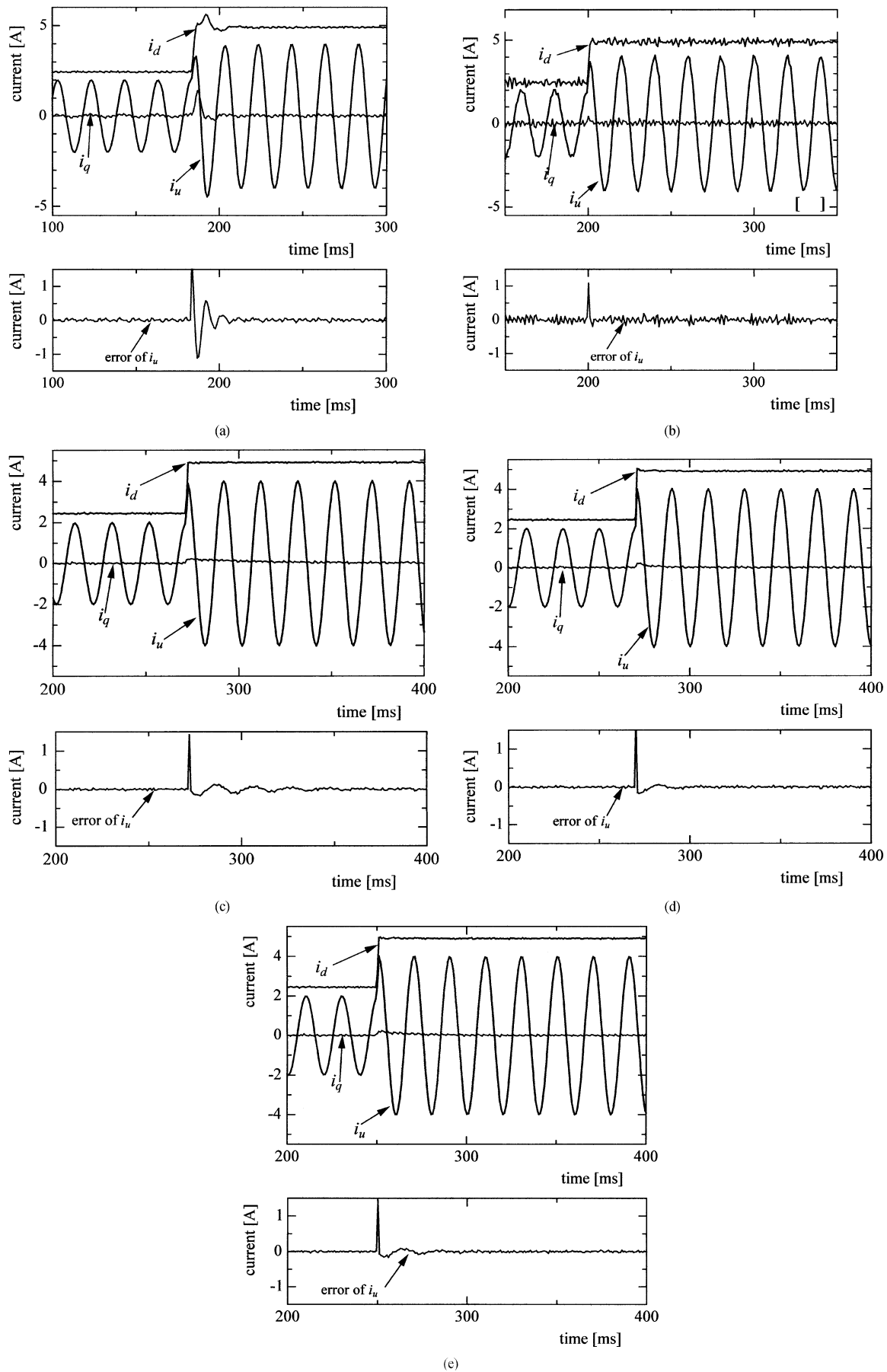

Fig. 2. Comparison of step responses with different PS gains, K_p and K_s . (a) $K_p = 10$ V/A, and $K_s = 10\,000$ V/A·s. (b) $K_p = 400$ V/A, and $K_s = 10\,000$ V/A·s. (c) $K_p = 100$ V/A, and $K_s = 5\,000$ V/A·s. (d) $K_p = 100$ V/A, and $K_s = 20\,000$ V/A·s. (e) $K_p = 100$ V/A, and $K_s = 10\,000$ V/A·s.

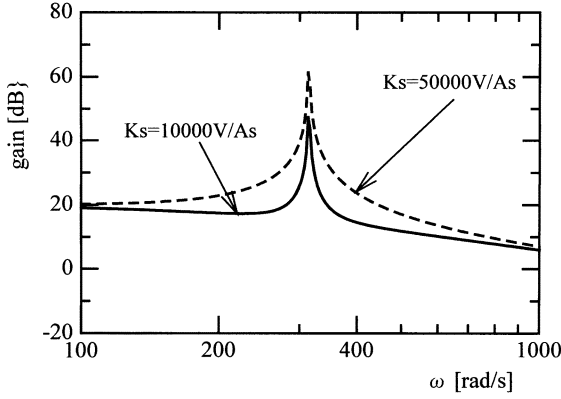

Fig. 3. Gain characteristics of the Bode diagram with different S regulator gain. $K_p = 100$ V/A constant.

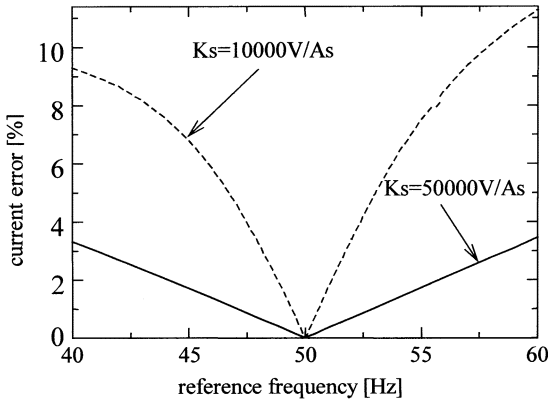

Fig. 4. Comparison of steady-state errors with different S regulator gain. $K_p = 100$ V/A constant.

B. Robustness of Current Control Using PS Regulator

The utility grid always has a slight frequency deviation. Should the resonant frequency ω_0 of the S regulator be adjusted so as to follow that slight deviation? To answer this question, the examination is made on the robustness of a sinusoidal internal model in terms of frequencies.

The gain diagram near the resonant frequency in Fig. 1 is enlarged, and shown in Fig. 3 together with the gain diagram with $K_s = 50\,000$ V/A·s. Fig. 3 indicates that a larger K_s results in a higher open-loop gain around the resonant frequency. Therefore, it is expected that a slight deviation in the utility frequency would not deteriorate the control performance if large K_s were selected. To confirm this fact, simulation was carried out using the current control system in (3), where the current reference was 5 A, and the reference frequency was varied from 40 to 60 Hz, while the resonant frequency of the S regulator and P gain were kept at $f_0 = 50$ Hz ($\omega_0 = 2\pi f_0$) and $K_p = 100$ V/A, respectively.

Fig. 4 shows the error versus reference frequency characteristic. One can observe the robustness in terms of frequency deviations if large K_s is selected. For example, if the deviation from 50 Hz is 2% ($\Delta f = 1$ Hz), the error is 1.7% with $K_s = 10\,000$ V/A·s, but is 0.35% with $K_s = 50\,000$ V/A·s. Since a practical frequency deviation of the utility grid would be less than 0.5% in Japan, it is no problem to keep the resonant frequency ω_0 of the S regulator constant.

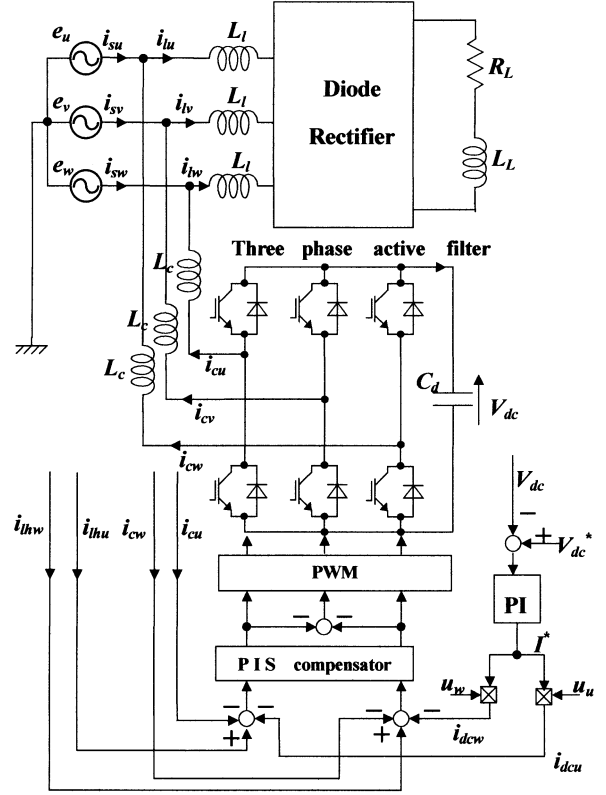

Fig. 5. Three-phase active filter with choke-input rectifier, and its control system.

III. THREE-PHASE AF

Fig. 5 shows the three-phase AF and load system. The control system used for the experiment is also shown in the figure. There are two control criteria:

- 1) dc voltage, V_{dc} , control;
- 2) three-phase output currents, i_{cu} , i_{cv} , i_{cw} , control.

In the dc voltage control, V_{dc} is measured and is kept constant at its reference V_{dc}^* . A PI regulator produces a dc current reference I^* . Active component currents i_{dcu} and i_{dcw} , which are required by the AF to compensate for its power losses, are obtained by multiplying I^* by the normalized voltage signals u_u and u_w which have unity amplitude and are in phase with the supply voltages e_u and e_w , respectively.

In the current control, the load currents i_{lu} and i_{lw} are measured, and their harmonic components i_{lhu} and i_{lhw} are extracted. Current references of the AF are composed of $i_{lhu} - i_{dcu}$ and $i_{lhw} - i_{dcw}$, respectively. The current control is executed using two PS regulators installed in phase u and phase w . Each PS regulator includes seven S regulators having different resonant frequencies. Each of the resonant frequencies is tuned to the fundamental, 5th, 7th, 11th, 13th, 17th, and 19th harmonics.

There are two kind diode rectifiers that act as a typical harmonic-producing load in the ac power lines:

- 1) choke-input rectifiers;
- 2) capacitor-input rectifiers.

Fig. 5 shows the AF with a choke-input rectifier, and Fig. 6 is the experimental current waveforms when the AF is operating.

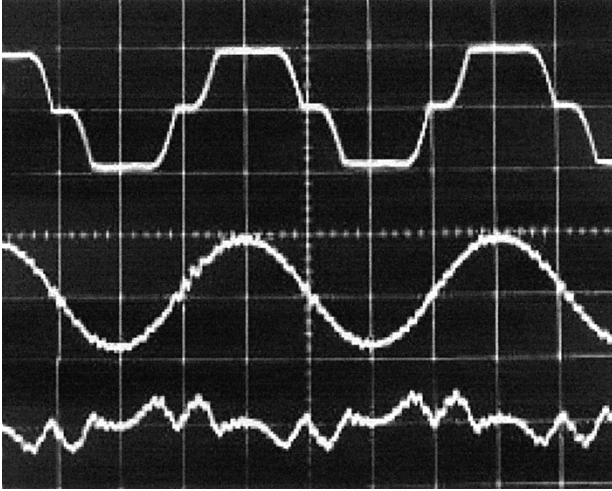

Fig. 6. Current waveforms of AF with a choke-input rectifier. Upper trace: load current i_{lu} ; middle trace: supply current i_{su} ; lower trace: compensation current i_{cu} . 10 A/div and 5 ms/div.

TABLE I
PARAMETERS USED FOR THE EXPERIMENTS

		AF	VSR	STATCOM
dc voltage	V_{dc}	200V	120V	200V
ac source voltage	E_l	100V	71V	100V
sampling and carrier frequency	f_s	10kHz	10kHz	10kHz
dc capacitor	C_d	940 μ F	940 μ F	940 μ F
interface reactor	L_c	5mH	5mH	5mH
series ac reactor	L_l	5mH	–	–
current control				
		100V/A	50V/A	70V/A
P gain	K_{lp}			
S gains for fundamental to 19 th harmonic	K_{i_s}	10000V/As	5000V/As	7000V/As
dc voltage control				
P gain	K_{vp}	0.0001A/V	0.2A/V	0.01A/V
I gain	K_{vi}	1A/Vs	10A/Vs	10A/Vs
load	R_l	13.7 Ω	20 Ω	13 Ω
	L_l	69mH	5mH	40mH
only used with capacitor input rectifier	C^	7333 μ F	–	–

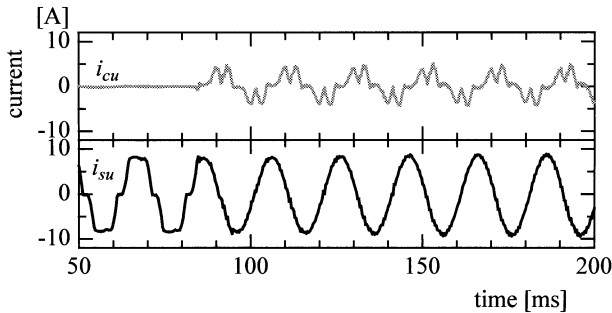

Fig. 7. Current responses when AF starts operation at $t = 82.6$ ms. Upper trace: compensation current of AF i_{cu} ; lower trace: supply current i_{su} .

The total harmonic distortion (THD) value of the load current i_{lu} was 16.4%, but the AF improved that of the supply current i_{su} as low as 2.0%. The parameters are listed in Table I.

Fig. 7 shows the current responses when the AF started operation at $t = 82.6$ ms. One can observe that the transient disappeared almost in a half cycle (10 ms) of the supply frequency.

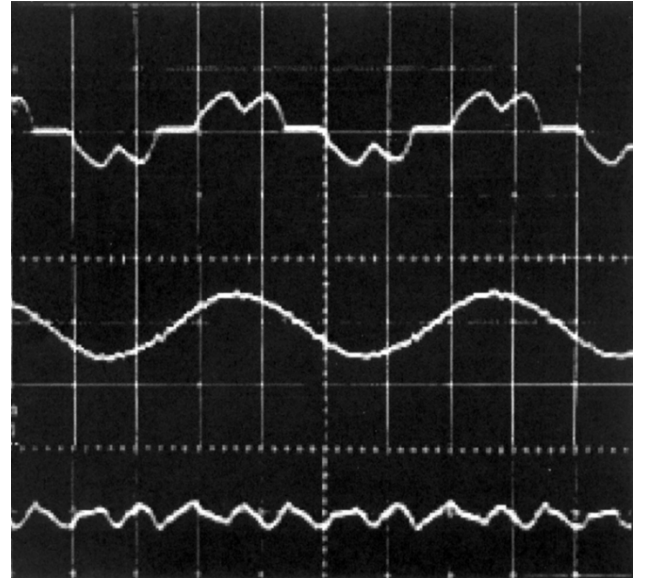

Fig. 8. Current waveforms of AF with a capacitor-input rectifier. Upper trace: load current i_{lu} ; middle trace: supply current i_{su} ; lower trace: compensation current i_{cu} . 10 A/div and 5 ms/div. (a) With only P regulator. (b) With PS regulator.

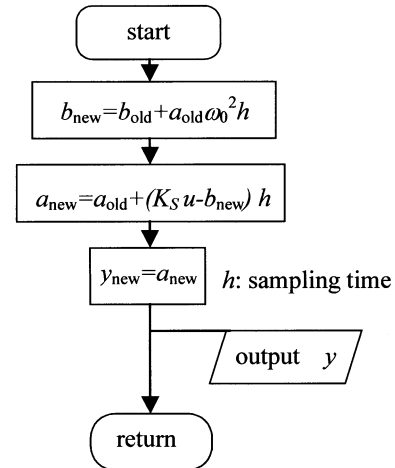

Fig. 9. Flowchart of S regulator used for experiment.

An experiment on an active filter with a capacitor-input rectifier was also conducted. In this case the dc capacitor C was connected across the dc load R_L-L_L in Fig. 5. Fig. 8 is the experimental current waveforms when the AF is operating. The THD value of the load current i_{lu} was 27.6%, while that of the supply current i_{su} was improved to 4.3%.

In the experiment a digital-signal-processor (DSP TMS320C32, 50 MHz)-based control system was used. The flowchart of an S regulator used is shown in Fig. 9, where u and y denote input and output signals respectively. Since its process is quite simple, only a short time was required to get the results, although 14 S regulators were used.

IV. THREE-PHASE VSR

A three-phase VSR is used as a utility interface of renewable energy sources and a front-end converter of adjustable-speed ac drives. A VSR is obtained if the diode rectifier in Fig. 5 is

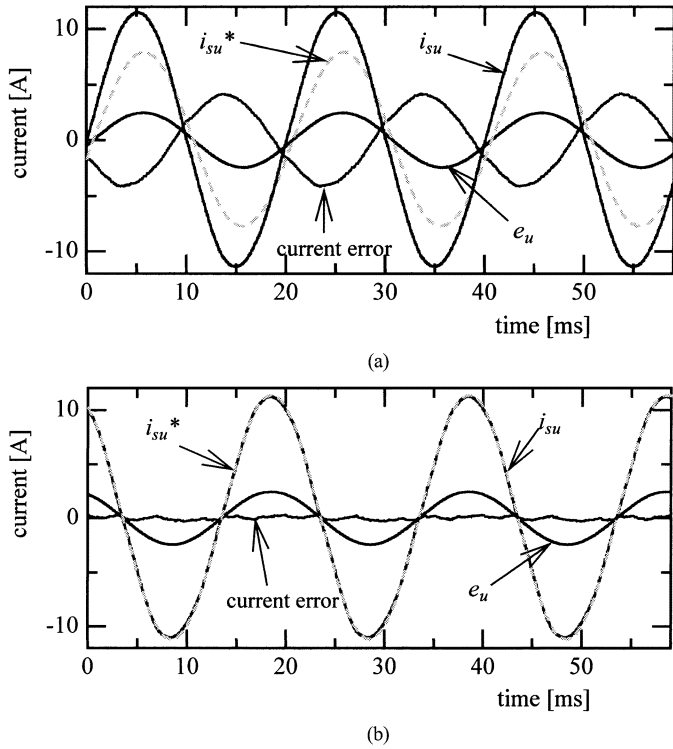

Fig. 10. Experimental waveforms of VSR. (a) With PI regulator. (b) With PIS regulator.

removed, and a dc load consisting of R_L and L_L is connected across the capacitor C_d . There are two control criteria:

- 1) dc voltage control;
- 2) three-phase current control.

The dc voltage control is the same as the AF described in Section III. The current control is similar to AF. VSR should draw sinusoidal currents with unity displacement power factor from the ac supply. Thus, an inverted form of the active currents, i_{dcu} and i_{dcw} , provides current references. The two PS regulators are installed in phase- u and phase- w to execute the current control. The parameters are listed in Table I.

Experimental waveforms without and with the S regulator are compared in Fig. 10(a) and (b), respectively. When only P regulators were used one can observe that the current waveforms were sinusoidal, but a considerable current error remained. This is because the reference signal is time varying. In contrast, when the PS regulators were used one can observe that the current error was kept at 0 A.

V. THREE-PHASE STATCOM

The circuit and control system of a STATCOM are quite similar to an AF. In a STATCOM, a three-phase ac load consisting of R and L connected in series replaces the diode rectifier in Fig. 5. The voltage control is the same as the AF described in Section III. The parameters are listed in Table I.

In the current control, the load currents in phase- u and phase- w are measured and their reactive components are extracted. The current references are an inverted form of the reactive component of the respective load currents. Two PS regulators execute this current control.

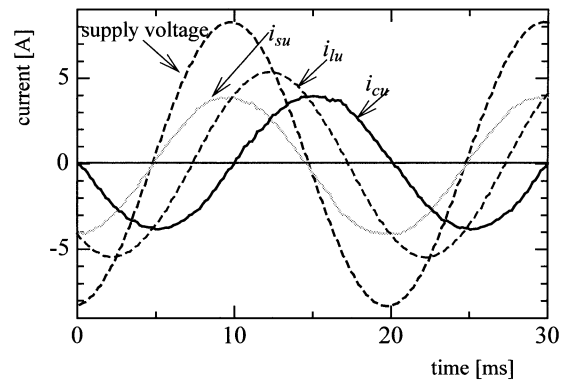

Fig. 11. Current waveforms of STATCOM with inductive load.

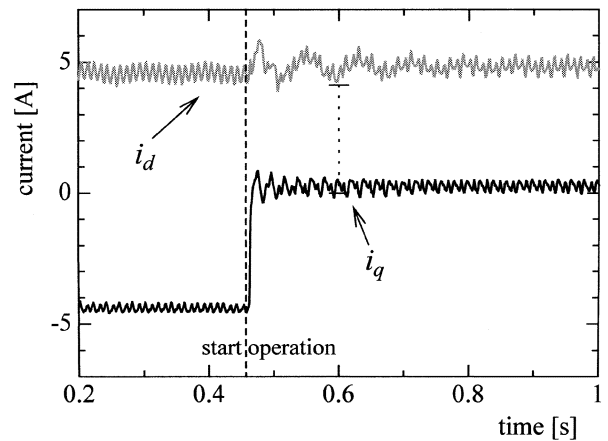

Fig. 12. Responses of supply currents when STATCOM starts operation at $t = 464$ ms. Upper trace: active component i_d ; lower trace: reactive component i_q .

Fig. 11 shows the voltage and current waveforms when the STATCOM was in operation. As the load was inductive, the load current lagged behind the supply voltage. When the STATCOM was not in operation the supply current and load current were the same, and were 3.75 A in rms. When the STATCOM was operated, it generated a current of 2.8 A to compensate for the reactive component of the load current. Thus, the supply current was reduced down to 2.8 A. One can observe that the supply current is in phase with the supply voltage, which ensures that the displacement power factor of the supply current was at unity.

Fig. 12 shows transient responses when the STATCOM started operation at $t = 464$ ms. In order to clearly distinguish an active component from a reactive component, the three-phase currents are intentionally represented in the synchronous d - q coordinate reference frame.

The currents i_d and i_q correspond to an active and reactive component in the synchronous reference frame, respectively. One can observe that the reactive component in the supply current disappeared in one cycle (20 ms).

VI. CONCLUSION

This paper has proposed the application of a PIS regulator to the current control of utility-interface converters. A PIS regulator does not require any coordinate transformations, but it can

track an arbitrary number of harmonic component, dc, and fundamental frequency reference signals with a zero steady-state error.

Since the line-side currents of utility-interface converters are required to track sinusoidal references synchronized with the utility grid, a PIS regulator is essentially suitable for their current control.

Three applications, a three-phase AF, a VSR, and a STATCOM, have been presented. The advantage of the PIS regulator has been verified by experimental results.

A set of sine transfer functions that results in almost the perfect tracking of harmonic components has been verified using the AF application. It is confirmed using the VSR that the steady-state error for a sinusoidal current reference has been zero. A sine transfer function that results in almost perfect compensation for a reactive component of load current has been verified using the STATCOM application.

Also, this paper has proposed a practical method for deciding gains of a P regulator and an S regulator, which the authors obtained empirically through their experiment.

REFERENCES

- [1] M. P. Skazmierkowski, R. Krishnan, and F. Blaabjerg, *Control in Power Electronics: Selected Problems*. New York: Academic, 2002.
- [2] *Power Electronics Handbook*, M. H. Rashid Blaabjerg, Ed., Academic, New York, 2001.
- [3] D. W. Novotny and T. A. Lipo, *Vector Control and Dynamics of AC Drives*. New York: Oxford Univ. Press, 1996.
- [4] D. G. Holmes and D. A. Martin, "Implementation of a direct digital predictive current controller for single and three phase voltage source inverters," in *Conf. Rec. IEEE-IAS Annu. Meeting*, 1996, pp. 906–913.
- [5] L. Malesani, P. Mattavelli, and P. Tomas, "Improved constant-frequency hysteresis current control of VSI inverters with simple feed-forward bandwidth prediction," in *Conf. Rec. IEEE-IAS Annu. Meeting*, 1995, pp. 2633–2640.
- [6] J. Holtz and S. Stadtfeld, "A predictive controller for the stator current vector of ac machines fed from a switched voltage source," in *Proc. IPEC-Tokyo*, 1983, pp. 1665–1675.
- [7] S. Fukuda and T. Yoda, "A novel current-tracking method for active filters based on a sinusoidal internal model," *IEEE Trans. Ind. Appl.*, vol. 37, no. 3, pp. 888–895, May/June 2001.
- [8] J. J. D'Azzo and C. H. Houpis, *Feedback Control System Analysis and Synthesis*. New York: McGraw-Hill, 1966.
- [9] S. Fukuda and R. Imamura, "Application of a sinusoidal internal model to current control of three phase utility-interface-converters," in *Proc. IEEE PESC'03*, vol. 3, 2003, pp. 1301–1306.



Shoji Fukuda (M'85–SM'96) received the M.E.E. and Ph.D. degrees in electrical engineering from Hokkaido University, Sapporo, Japan, in 1967 and 1977, respectively.

From 1981 to 1983, he conducted research at the University of Saskatchewan, Saskatoon, SK, Canada, as a Postdoctoral Fellow. He is currently an Associate Professor with the Graduate School of Information Science and Technology, Hokkaido University. He has been engaged in research on ac drives, PWM control of rectifiers/inverters, and active filters.

Dr. Fukuda is a Member of the Institute of Electrical Engineers of Japan and the Japan Institute of Power Electronics.



Ryota Imamura was born in Japan in 1976. He graduated from and received the M.E.E. degree from Hokkaido University, Sapporo, Japan, in 2000 and 2002, respectively.

In 2002, he joined Hitachi Ltd., Hitachi, Japan, where he is currently with the Patent Department 1, IP Development and Management Division. He has been engaged in patent affairs on motor drives for the Hitachi Research Laboratory. His research interest is power electronics.

Mr. Imamura is a Member of the Institute of Electrical Engineers of Japan.