

Application of ANN and ANFIS models for reconstructing missing flow data

Mohammad T. Dastorani · Alireza Moghadamnia ·
Jamshid Piri · Miguel Rico-Ramirez

Received: 20 September 2008 / Accepted: 17 May 2009 / Published online: 20 June 2009
© Springer Science + Business Media B.V. 2009

Abstract Hydrological yearbooks, especially in developing countries, are full of gaps in flow data series. Filling missing records is needed to make feasibility studies, potential assessment, and real-time decision making. In this research project, it was tried to predict the missing data of gauging stations using data from neighboring sites and a relevant architecture of artificial neural networks (ANN) as well as adaptive neuro-fuzzy inference system (ANFIS). To be able to evaluate the results produced by these new techniques, two traditionally used methods including the normal ratio method and the correlation method were also

employed. According to the results, although in some cases all four methods presented acceptable predictions, the ANFIS technique presented a superior ability to predict missing flow data especially in arid land stations with variable and heterogeneous data. Comparing the results, ANN was also found as an efficient method to predict the missing data in comparison to the traditional approaches.

Keywords Hydrological data · Data gap filling · Artificial neural networks · Neuro-fuzzy systems

Electronic supplementary material The online version of this article (doi:10.1007/s10661-009-1012-8) contains supplementary material, which is available to authorized users.

M. T. Dastorani (✉)
Faculty of Natural Resources, Yazd University,
Yazd, Iran
e-mail: mdastorani@yazduni.ac.ir

A. Moghadamnia
University of Zabol, Zabol, Iran
e-mail: ali.moghaddamnia@gmail.com

J. Piri
Jahad Keshavarzi of Sistan Region, Zabol, Iran

M. Rico-Ramirez
Faculty of Engineering, University of Bristol,
Bristol, UK

Introduction

Data acquisition systems are often characterized by short breaks in their records. This may be attributed to various reasons such as absence of the observer, instrumental failures, power failure, or communication line breakdown. This problem is more serious in developing countries, and in these countries, for most of the areas, hydrological data series are full of gaps in flow data series. If such data are to be utilized in real-time decision support and control systems, serious disasters may occur. Control actions become crippled due to incomplete real-time data (Abebe et al. 2000). One such data set used widely in water-based decision support system is flow time series. Planning and management as well as design and construction of

any hydraulic structure across or along rivers are dependent on these data. Filling missing records is needed to make feasibility studies, potential assessment, and real-time decision making. Therefore, to be able to use these data more efficiently, the gaps need to be filled or, in some cases, short period of data to be prolonged (extrapolation) using relevant and efficient methods. There are some existing methods used for rainfall as well as flow data gap filling. Some of these methods are relevant only to rainfall data gap filling, and some of them can be used for both rainfall and flow missing data estimation (Linsley et al. 1988). Two well-known methods which are commonly used for filling flow data gaps are the normal ratio method (NRM) and especially the correlation method (CM) between the gauging stations.

In the last few decades, many types of data-driven techniques and models have been developed and they reflect the inherently stochastic nature of hydrologic processes and this has led to an increasing interest in artificial neural network (ANN) and fuzzy logic techniques. ANN, adaptive neuro-fuzzy inference system (ANFIS), and fuzzy logic techniques that consider the nonlinearity in the rainfall-runoff process and the utilization of soft computing techniques such as support vector machines, expert systems, and genetic algorithms are grouped under the general description “artificial intelligence.”

These new machine learning techniques, especially ANN and neuro-fuzzy methods, have been used to solve different hydrology and water resources problems during the last decades and, in most of the cases, presented very good results. The technique of ANN is widely used as an efficient tool in different areas of water-related research activities. Bhattacharya and Solomatine (2000) used this technique to evaluate stage–discharge relationship; Dawson and Wilby (1998a) applied ANN for rainfall-runoff modeling; Dawson and Wilby (1998b) also compared the application of different types of ANN for river flow forecasting; Hsu et al. (1995) evaluated the application of ANN for rainfall-runoff process; Karunanithi et al. (1994) predicted river flow using adaptive ANN; Luk et al. (1998) tried to forecast rainfall

events using ANN; Minns and Hall (1996), and Tokar and Johnson (1999) employed this method as a tool of rainfall-runoff modeling; Dastorani and Wright (2004) employed ANN to optimize the results of a hydrodynamic approach for river flow prediction; Dastorani and Wright (2003) completed a research project on flow estimation for ungauged catchments using a neural network method; and Dastorani and Wright (2002) used ANN for real-time river flow prediction in a multistation catchment.

This research was designed to investigate the capabilities of new data-driven techniques to fill the gaps of hydrological data series measured in some gauging stations located in various climate conditions in Iran. This study deals with the reconstruction of missing flow records from observational data obtained from adjacent stations using new machine learning techniques including adaptive ANN as well as ANFIS models. The results are then compared with those obtained from traditional methods. According to the application of the new techniques (ANN and ANFIS) reported from studies completed in other aspects of hydrology and water resources, the main hypothesis of this research was created. The main hypothesis of this study is: “preference of the new data-driven techniques over traditional methods on missing flow data reconstruction.” This hypothesis would be accepted or rejected according to the final results.

Methods and materials

Study area characteristics

In this research project, after the selection of ten gauging stations located in different parts of Iran, they were organized in four groups due to geographical proximity. In each group, one of the stations was selected as subject station, and it was tried to predict the missing data of the selected station using data from other stations of the same group, and a relevant architecture of the ANN model and also adaptive neuro-fuzzy technique. Figure 1 presents a schematic plan of the study

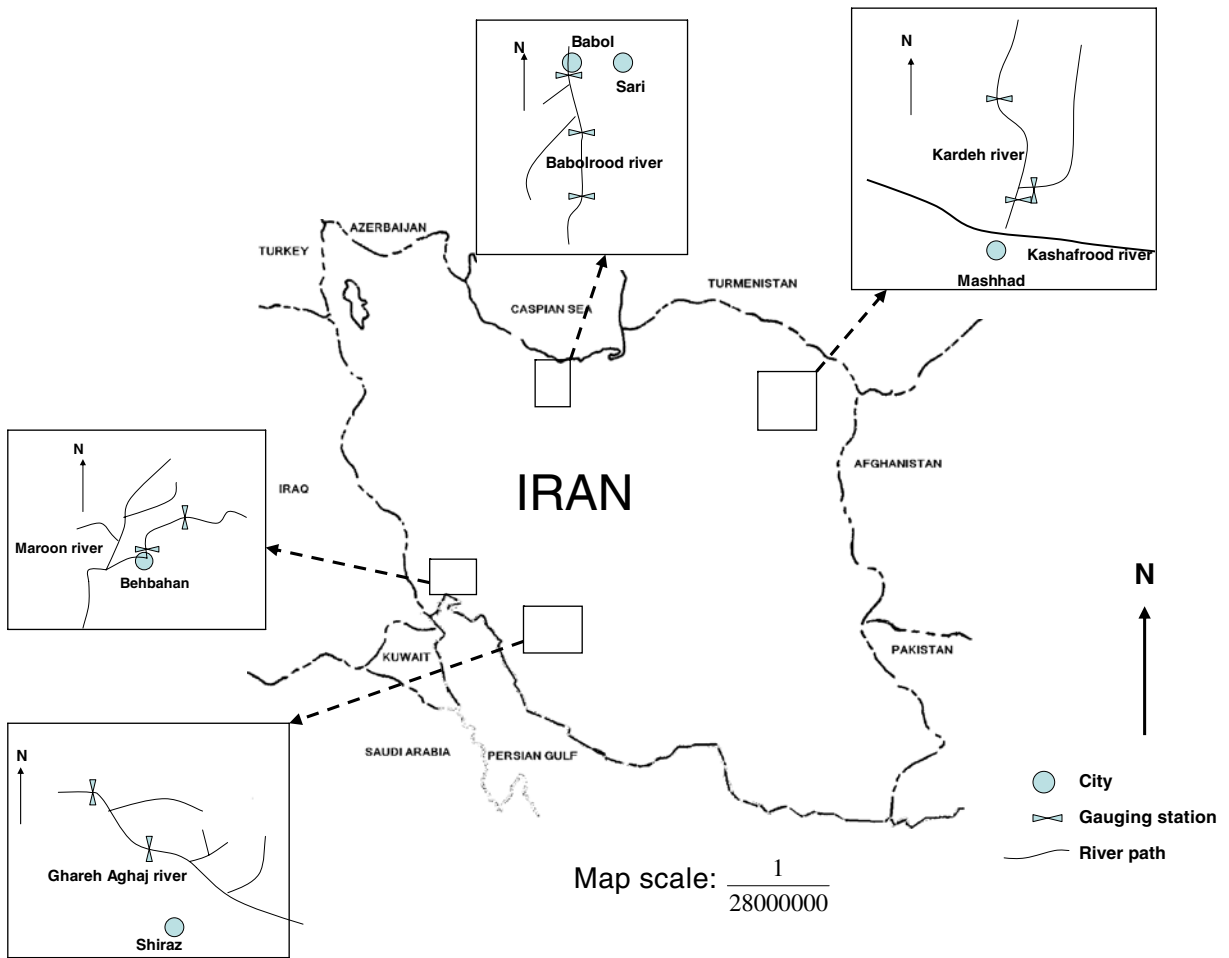

Fig. 1 A schematic plan of the study area showing the location of river paths and the related gauging stations

area showing the location of river paths and the related gauging stations. These four subject gauging stations in which their monthly flow data was reconstructed in this research are as follows:

- Kardeh station located across the Kardeh River in Khorasan province, a semiarid region.
- Babol station located across the Babol River in the north of Iran, a humid and semihumid region.
- Behbahan station located across the Maroon River in Khozestan province, an arid region.

- Aliabad station located across the Gharah Aghaj River in the central west of Iran, an arid area.

Table 1 shows the details and characteristics of the stations and data used in this research. As it is seen from the table, groups 1 and 2 include three flow gauging stations, while groups 3 and 4 contain only two stations. In each of groups 1, 3, and 4 are all related stations located along the same river, but in group 2, stations Kooshk and Jong measure flow in two different tributaries and Kardeh station measures flow downstream after conjunction of the tributaries. The table also shows that

Table 1 Details and characteristics of stations and data used in this research

Group	Stations	River	Area above station (km ²)	Elevation (m above sea level)	Subject station to fill data gap	Length of data used for training (calibration), years
1	Babol	Babolrood	1,430	0	Babol	6
	Pasha Kola		152	212		
	Ghoran-Talar		403	150		
2	Kooshk	Kardeh	93	980	Kardeh	7
	Jong		95	1,680		
	Kardeh		432	980		
3	Idnak	Maroon	2,746	560	Behbahan	27
	Behbahan		3,740	280		
4	Bande-Bahman	Aliabad	2,410	1,700	Aliabad	17
	Aliabad		3,570	1,340		

data record length available to use for training of the models in this research was different for the groups (from 6 years in group 1 to 27 years in group 3). To be able to compare the results produced by these models, the NRM as well as the CM was also employed to predict missing data. Then, the values of the root mean square error (RMSE) and coefficient of determination (R^2) were determined for the predicted values of each method and the corresponding measurements to evaluate applicability of the used methods. Figure 1 presents a schematic plan of the study area showing the location of river paths and the related gauging stations. It needs to be added that, for the testing phase of modeling, independent data sets (not used in training or calibration) were used. The length of monthly flow data used for testing was 1 year for groups 1, 2, and 3 and 2 years for group 4. As the four methods used to reconstruct data in this research are compared in each station separately and independent from other stations, differences in number of stations and data length in the groups can be a positive point to evaluate the ability of the methods in different conditions.

Artificial neural networks

An ANN is an interconnected group of artificial neurons that uses a mathematical model for information processing based on a connectionist approach to computation. In most cases, an ANN is an adaptive system that changes its structure based on external or internal information that flows through the network. In more practical

terms, neural networks are nonlinear statistical data-modeling tools. They can be used to model complex relationships between inputs and outputs or to find patterns in data (Lucio et al. 2007). In many applications, modeling tools have provided better results when used in hydrological time series analysis (Elshorbagy et al. 2002). Neural networks must be trained with a set of typical input/output pairs of data called the training set. The final weight vector of a successfully trained neural network represents its knowledge about the problem. As different types of neural network deal with the problems in different ways, their ability varies depending on the nature of the problem in hand. Therefore, three types of ANN were used in this study: multilayer perceptron (MLP), which is a static architecture of neural networks, as well as recurrent and time-lagged recurrent neural networks, which are dynamic networks.

Multilayer perceptron neural network

In this network, a connection is allowed from a node in layer i only to nodes in layer $i + 1$ and not vice versa (Fig. 2). An advantage of MLP in terms of mapping abilities is its capability of approximating arbitrary functions. This is an important point in the study of nonlinear dynamics and other function mapping problems. In this study, different types of transfer and output functions for hidden and output layers as well as different numbers of hidden layers were used to find the best structure of MLP for this application. From these trials, it was found that the tangent hyperbolic function was the most compatible one for the

Fig. 2 A typical three-layer feed forward neural network

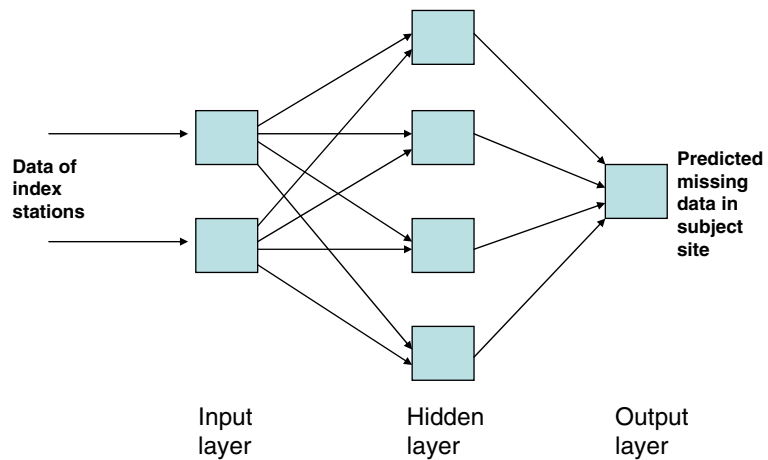

hidden layer. However, for the output layer, the sigmoid function was the most suitable one. In this study, only one hidden layer was the most suited number of this type of layers for the ANN model.

Recurrent neural networks

This type of network can be divided into fully and partially recurrent. Having a memory element distinguishes this network from the previous one. Although recurrent networks are more powerful than feed forward networks, they are more difficult to train and their properties are not as well understood. The training of a recurrent network is much more sensitive to divergence (NeuroDimension 2001). To construct the best architecture for this study, many structures were tested and the results were considered. The number of hidden layers, number of processing elements in hidden layers, type of transfer and output functions, and type of learning rule and its parameters have been considered and evaluated. After using different types of transfer and output functions for hidden and output layers and comparison of the results, it was found that a tangent hyperbolic function is the most suitable one for the hidden layer. However, for the output layer, the sigmoid function is a more compatible function. It needs to be mentioned that the Neurosolution software package (from NeuroDimension) was used to create and run ANN models in this research. Between the dynamic processing elements of gamma, Laguarre, and time delay, the Laguarre and time delay gave

better results. For this research, the partially recurrent network showed better adaptation than the fully recurrent one, and the best results were produced when only one hidden layer was used in the model.

Time-lagged recurrent neural networks

This type of network contains locally recurrent layers with a single adaptable weight. As opposed to the recurrent networks, stability in time-lagged recurrent networks is guaranteed. It usually suits temporal problems with short temporal dependency; however, it does not seem appropriate for more difficult temporal problems. For this type of neural network, it was found that the tangent hyperbolic function and, in few cases, the sigmoid function was the best one for the hidden layer. However, for the output layer, the sigmoid function suited better. Between the dynamic processing elements of gamma, Laguarre and time delay, gamma was found to be the most compatible. Networks with only one hidden layer presented the best performance.

Between the above-mentioned three ANN architectures, overall, the MLP network presented better performance for the reconstruction of flow data in comparison to the other two networks.

Adaptive neuro-fuzzy inference system

ANFIS is a new improved tool and a data-driven modeling approach for determining the behavior of imprecisely defined complex dynamical systems

(Kim and Kasabov 1999). The ANFIS model has human-like expertise within a specific domain—it adapt itself and learns to do better in changing environments (Kurian et al. 2006). An ANFIS aims at systematically generating unknown fuzzy rules from a given input/output data set (Abraham et al. 2004). Figure 3 represents a typical ANFIS architecture that is based on:

Layer 1 Every node in this layer is an adaptive node with a node function that may be a generalized bell membership function (Eq. 1), a Gaussian membership function (Eq. 2), or any membership functions:

$$\mu_{A_i}(x) = \frac{1}{1 + \left| \frac{x - c_i}{a_i} \right|^{2b_i}}, \tag{1}$$

$$\mu_{A_i}(x) = \exp \left[- \left(\frac{x - c_i}{a_i} \right)^2 \right] \tag{2}$$

where a_i , b_i , and c_i are premise parameters. Also, x is the input to node i and A_i is the linguistic label (for example, low and high) associated with this node function. Premise parameters change the shape of the membership function.

Layer 2 Every node in this layer is a fixed node labeled Π , representing the firing strength of each

rule, and is calculated by the fuzzy AND connective of “product” of the incoming signals by using Eq. 3:

$$w_i = \mu_{A_i}(x) \times \mu_{B_i}(x) \tag{3}$$

$i = 1, 2$

where $\mu_{A_i}(x)$ and $\mu_{B_i}(x)$ are the membership grades of fuzzy sets A and B and also w_i is the firing strength of each rule.

Layer 3 Every node in this layer is a fixed node labeled N , representing the normalized firing strength of each rule. The i th node calculates the ratio of the i th rule’s firing strength to the sum of the two rules’ firing strengths by using Eq. 4:

$$\bar{w}_i = \frac{w_i}{w_1 + w_2} \tag{4}$$

$i = 1, 2$

where \bar{w}_i is the normalized firing strength that is the ratio of the i th rule’s firing strength (w_i) to the sum of the first and second rules’ firing strengths (w_1, w_2).

Layer 4 Every node in this layer is an adaptive node with a node function (Eq. 5), indicating the contribution of i th rule toward the overall output:

$$w_i z_i = w_i (p_i x + q_i y + r_i) \tag{5}$$

where z_i is equal to $(p_i x + q_i y + r_i)$ and also p_i, q_i , and r_i are consequent parameters.

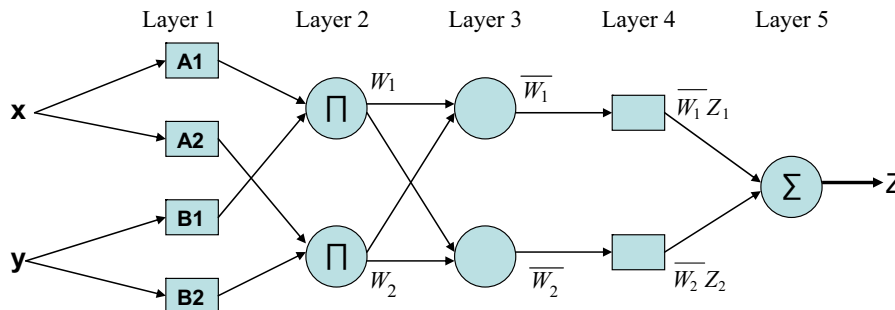

Fig. 3 A typical ANFIS architecture (Jang 1993). In this figure, x and y are the inputs and z is the final output, A_1 , A_2 , B_1 , and B_2 are the linguistic label (*small, large*, etc.) associated with this node function, \bar{w}_i is the normalized fir-

ing strength that is the ratio of the i th rule’s firing strength (w_i) to the sum of the first and second rules’ firing strengths (w_1 and w_2), and Π is the node label

Layer 5 The single node in this layer is a fixed node labeled Σ , indicating the overall output as the summation of all incoming signals calculated by Eq. 6:

$$Z = \sum_i w_i z_i = \frac{\sum_i w_i z_i}{\sum_i w_i} \tag{6}$$

where Z is the summation of all incoming signals.

What is important when inspecting the above layers is principally three different types of components that can be adapted as follows (Lughofer 2003):

1. Premise parameters as nonlinear parameters that appear in the input membership functions.
2. Consequent parameters as linear parameters that appear in the rules consequents (output weights).
3. Rule structure that needs to be optimized to achieve a better linguistic interpretability.

In this study, three Gaussian membership functions were used for the input variable. There are a wide variety of algorithms available for training a network and adjusting its weights. In this study, an adaptive technique called “momentum Levenberg–Marquardt” based on the “generalized delta rule” was adapted (Rumelhart et al. 1986). In this scheme, the adaptive learning rates were used for adapting the increasing convergence velocity throughout all ANFIS simulations.

The normal ratio method

This traditional statistical pattern recognition method uses normal flow of the station under consideration and the adjacent stations over a certain period of time to forecast or estimate missing records that exist in the station under consideration (Linsley et al. 1988). In this method, some stations are selected around the subject station called “index stations” where measured data are available for the related time period.

The data recorded at the index stations are weighted by the ratios of the normal annual flow

values. Thus, the flow data F_X at station x (subject station or station under consideration) is:

$$F_X = \left(\frac{1}{2}\right) \left(\frac{\overline{F_X}}{\overline{F_A}} F_A + \frac{\overline{F_X}}{\overline{F_B}} F_B\right) \tag{7}$$

where X is the subject station and A and B are the index stations (adjacent stations), F_X is the missing data in subject station to be predicted, $\overline{F_X}$ is the normal flow (mean of index period) in the subject station, $\overline{F_A}$ is the normal flow (mean of index period) in index station A, and $\overline{F_B}$ is the normal flow (mean of index period) in index station B.

In this research, the same set of training data (used for ANN and ANFIS) was used to calculate the normal flow (mean flow) of the three stations (in each group). The rest of the data are then used in Eq. 7 to verify the method.

The correlation method

In this traditional common method, the correlation between data of the subject station and each of the preselected stations is evaluated using following equation (Eq. 8):

$$r = \frac{\sum xy - \frac{\sum x \sum y}{n}}{\sqrt{\left[\sum x^2 - \frac{(\sum x)^2}{n}\right] \left[\sum y^2 - \frac{(\sum y)^2}{n}\right]}} \tag{8}$$

where y is the existing data series of subject site, x is the existing data series of the index site, and n is the existing number of measurements.

It must be mentioned that the amount of correlation coefficient (r) between the data of the subject site and index site must be in an acceptable level according to the Fisher table. As in this method, only one index station is used to reconstruct missing data of the subject site. Therefore, in this study, for each group of stations, the correlation coefficient (r) between the data of the subject site and the other two stations in the same group was separately calculated and the station having higher correlation with the subject site was chosen as index station. Missing data of subject station was then predicted using Eq. 9:

$$Y = a + b X \tag{9}$$

where Y is the missing observation to be predicted and X is the observation of the index site corresponding to the missing data of the subject site (Y). The values of a and b can be calculated using Eqs. 10 and 11, respectively:

$$a = \bar{y} - b\bar{x}, \quad (10)$$

$$b = \frac{\sum xy - \frac{\sum x \sum y}{n}}{\sum x^2 - \frac{(\sum x)^2}{n}} \quad (11)$$

where \bar{y} and \bar{x} are the mean values of the existing data series, respectively, in the subject and the index stations.

Performance criteria

In this study, two performance criteria are used: RMSE and R^2 . RMSE is calculated by Eq. 12:

$$\text{RMSE} = \sqrt{\frac{1}{N} \sum_{i=1}^N (O_i - P_i)^2} \quad (12)$$

where N is the number of data points, O_i is the observed value, and P_i is the predicted value.

R^2 assesses the goodness of fit by indicating the deviation of the estimated values from the line of the best fit or the regression line. The R^2 value is between zero and unity. A value close to unity indicates a satisfactory result, while a low value or close to zero implies an inadequate result. R^2 is calculated by Eq. 13:

$$R^2 = 1 - \frac{\sum_{i=1}^n (O_i - P_i)}{\sum_{i=1}^n (O_i - \bar{O})} \quad (13)$$

where O_i and P_i are the observed and predicted values at data point i , respectively, \bar{O} is the mean of the observed values, and n is the number of data points.

Results and discussion

Reliability of a decision support system or the quality of the results obtained from a model

depends on the quality of the input data and, most critically, on the presence of data itself. It is likely that a decision support system may fail if there is no sufficient data to deal with. This may be overcome either by knowing what to do with the available data or by generating the missing data using some mechanism. The former approach is tedious since the system should have alternative way-outs for every missing data that could cripple the decision making. The latter involves some mechanism to reconstruct the missing data based on some rules. Such rules may come from insights from the nature of the physical system and the particular data to be reproduced. As mentioned earlier, this study evaluated the suitability of four different methods to fill the gaps of flow data records. The quality of the results produced by these methods varies, and as Figs. 4, 5, 6, and 7 as well as Table 2 show, in all cases, ANFIS presented the most accurate results in comparison to the other applied methods. According to the results, it can also be said that ANN is an efficient method to predict the missing data. In all of the cases in this research, the accuracy of the results produced by ANN is quite acceptable and higher than those produced by two traditional approaches (NRM and CM). However, in Kardeh station, the outputs of NRM is quite near to those of ANN (slightly lower in accuracy), and also in Babol station, the accuracy of the ANN results is slightly higher than those of CM. In all four stations, the accuracy of the ANN outputs are lower than those produced by ANFIS. MLP was the most relevant architecture of ANN for this application, although in few cases, the outputs of the recurrent network were almost similar to the results presented by the MLP network. The results shown in Figs. 4 to 7 are summarized in Table 2. The statistical criteria including RMSE and R^2 for comparing the models under consideration are given in this table.

The four methods mentioned are applied to the same problem under similar conditions and compared with the same performance indices. Referring to the relative performance of the four methods (Figs. 4 to 7 and Table 2), it can be observed that the highest R^2 as well as the lowest RMSE between the observed and simulated results in all of the stations is observed from using

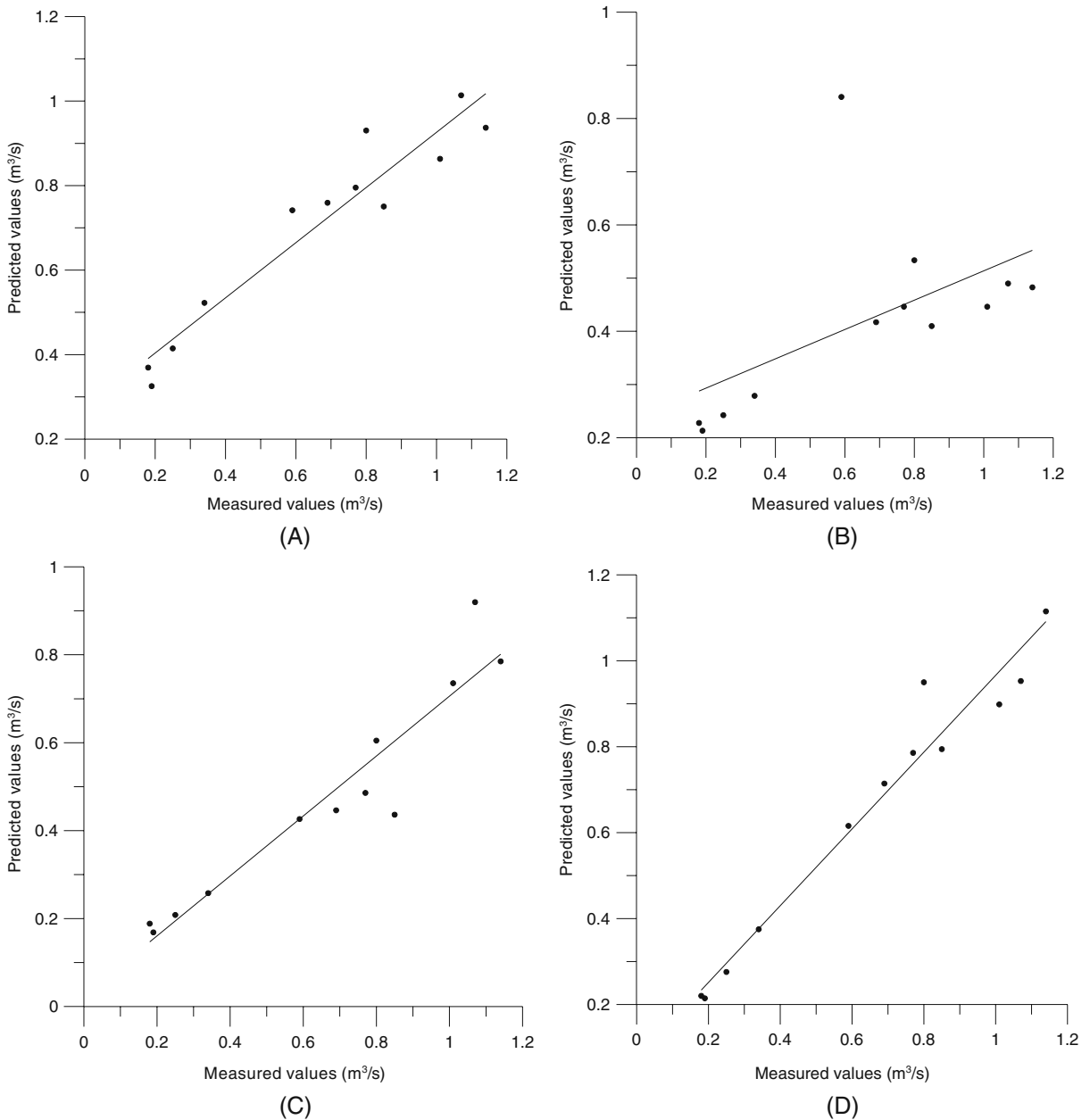

Fig. 4 Measured data and the predictions produced by different methods for Kardeh gauging station. NRM (a), CM (b), ANN (c), and ANFIS (d)

the ANFIS method. In fact, these results indicate that the ANFIS is superior for the estimation of missing observations. Such superiority may be problem-related and need extensive applications on various data sets to be generalized. However, one can say that the superiority of this technique

might be attributed to its ability to capture the nonlinear dynamics of the data.

Table 2 and also Figs. 4 to 7 clearly show that the behavior of the used models varies in dealing with data in different gauging stations of this study. For the prediction of monthly missing

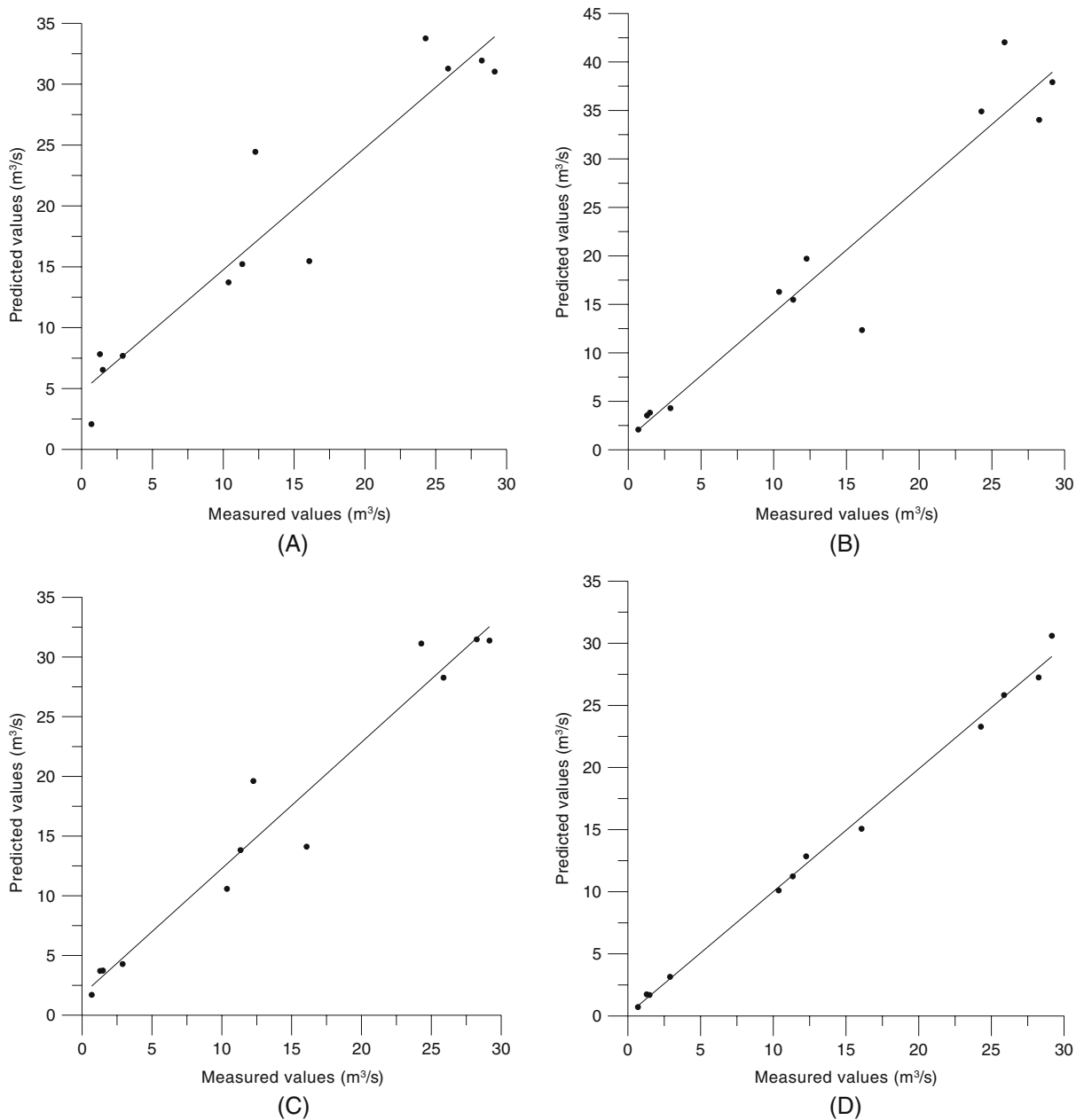

Fig. 5 Measured data and the predictions produced by different methods for Babol gauging station. NRM (a), CM (b), ANN (c) and ANFIS (d)

flow data in Kardeh station, NRM and ANN performance is quite acceptable, while ANFIS performed well with the highest accuracy of the predictions, and CM could not present acceptable results. For the Babol station, all four methods showed relatively good performance, although the level of accuracy is different and ANFIS

presented the highest accuracy. For this station, the accuracy of outputs decreases gradually from ANN to CM and CM to NRM, respectively. For the Aliabad station, again, the best results were produced by the ANFIS model; the ANN presented quite acceptable results with accuracy higher than NRM and CM and lower than those of

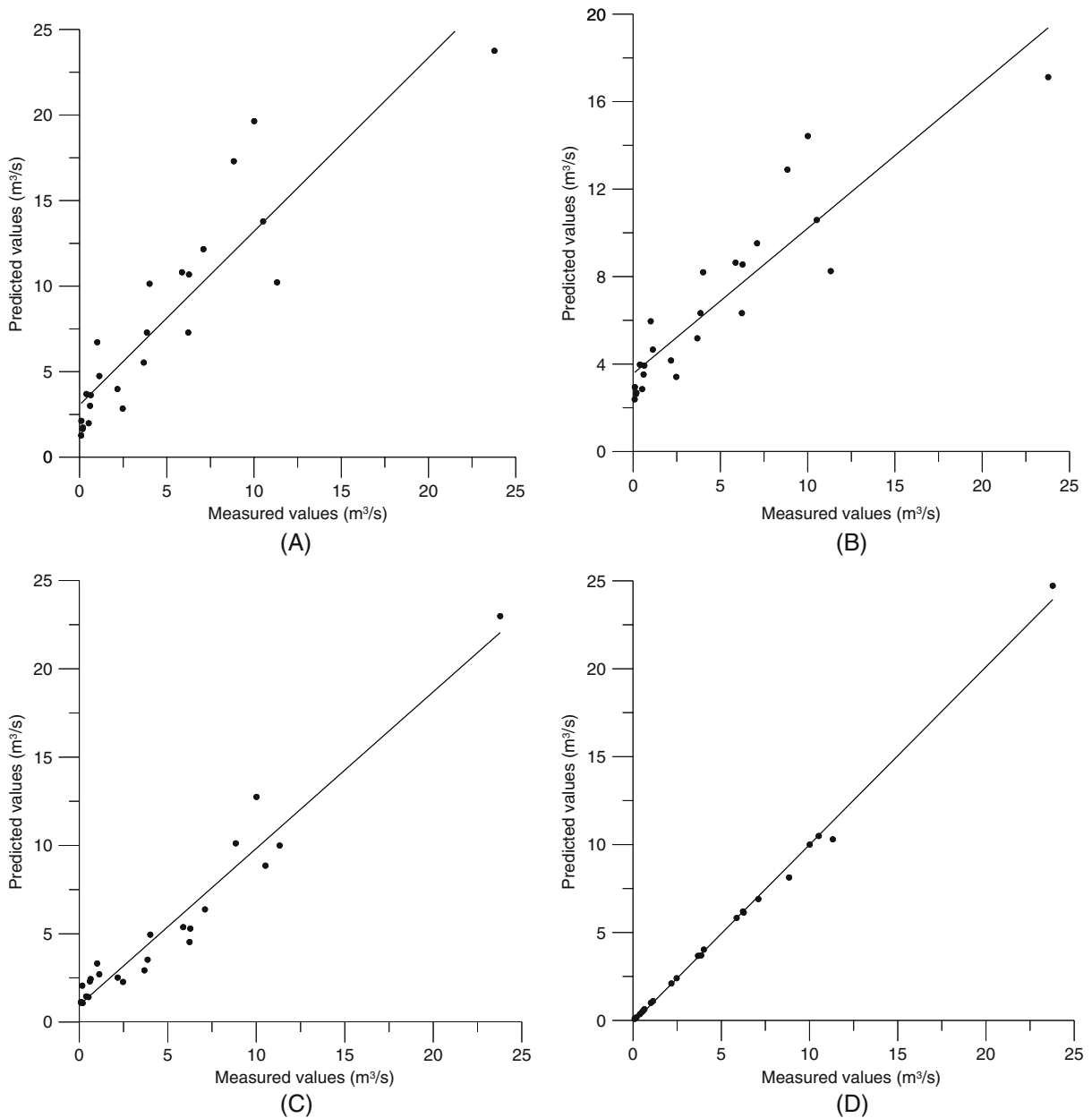

Fig. 6 Measured data and the predictions produced by different methods for Aliabad gauging station. NRM (a), CM (b), ANN (c) and ANFIS (d)

ANFIS. The results of NRM and CM methods are almost similar to each other in this station. For Behbahan station, NRM and CM methods could not present acceptable results, while the performance of ANN is quite acceptable and ANFIS showed superior ability to predict monthly missing flow data for this station.

Among the four stations, Babol station is located in humid and semihumid regions of northern Iran with the lowest coefficient of variation on stream flow data and where all four applied methods are able to reconstruct missing data with an acceptable level of accuracy. The other three stations are located in arid and semiarid regions

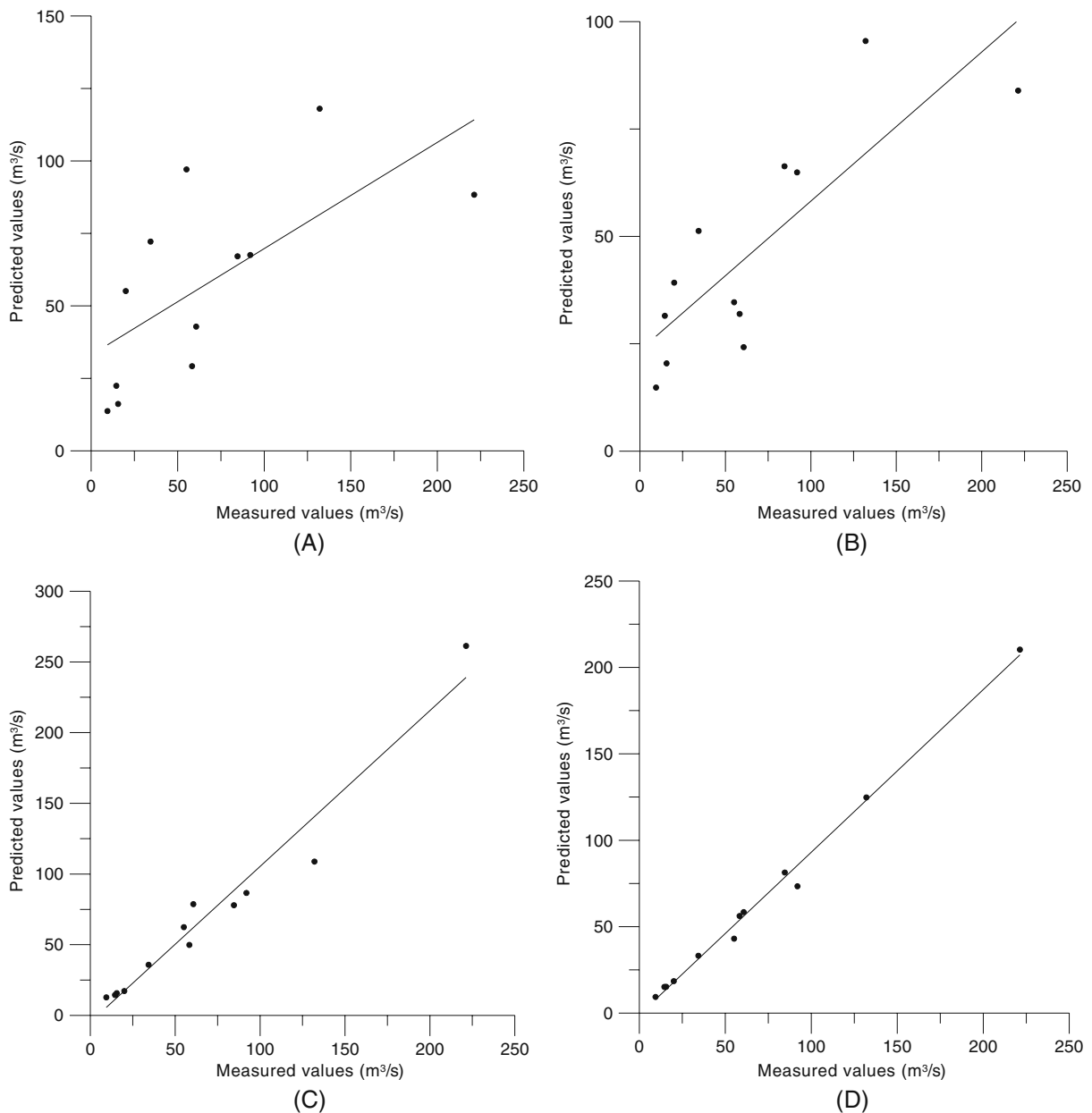

Fig. 7 Measured data and the predictions produced by different methods for Behbahan gauging station. NRM (a), CM (b), ANN (c) and ANFIS (d)

with more variable flow regime and higher rates of coefficient of variation. As the figures and tables of the results show, in all of these three stations, traditional methods (NRM and CM) more or less have had problems presenting acceptable results,

while the results of new machine learning techniques (ANN and ANFIS) and especially ANFIS show high levels of accuracy. This clearly indicates that the new techniques have good ability to deal with variable and heterogeneous data and can be

Table 2 The statistical criteria of RMSE and R^2 used for performance evaluation of the used methods

Gauging station	RMSE				R^2			
	NRM	CM	ANN	ANFIS	NRM	CM	ANN	ANFIS
Kardeh	0.225	0.365	0.140	0.069	0.902	0.302	0.914	0.961
Babol	5.806	7.189	3.487	0.696	0.908	0.926	0.957	0.996
Aliabad	4.012	3.159	1.337	0.325	0.824	0.824	0.949	0.997
Behbahan	45.138	45.372	14.957	7.570	0.444	0.675	0.958	0.993

good solutions for hydrological problems of arid and semiarid regions where most of the modeling tools cannot perform well.

It should be noted that some recent studies have indicated that the noise that exists in hydrologic data may limit the performance of many modeling techniques. Some methods have been proposed to reduce the level of noise in the data set, which may lead to improvement in the accuracy of the estimation of missing data. However, new machine learning techniques such as ANN and ANFIS have better ability to deal with the problem of noise in data.

Conclusions

This research was designed to evaluate the applicability of new machine learning techniques including ANN and ANFIS for the reconstruction of hydrological data under different climatic regions. It would be interesting to compare the data-driven models with traditional methods. According to the results, the ANFIS model shows superiority in the accuracy of estimating the missing data. The results produced by ANN also show a good level of accuracy. In all the cases used in this study, the accuracy of the results produced by these techniques (especially ANFIS) was higher than those produced by the other two methods (NRM and CM). The present study confirms the very high potential of the ANFIS model to be used for reconstructing missing flow data. It must be added that the performance of ANN is also quite acceptable to deal with this problem in comparison to the traditionally used approaches.

In accuracy of predicting missing flow data, it seems that the techniques employed in this article

can perform quite well especially with variable, heterogeneous, and noisy data in arid and semi-arid regions and can be used as a powerful tool over existing methods for filling hydrological time series gaps.

Due to lack of appropriate performance of traditional and statistical formulae used in hydrology, the interest of applying data-driven models like ANN and ANFIS to hydrological simulations has to be further accelerated. One of the major limitations of ANN is their lack of explanatory power, also referred to as their “black box problem.” Neuro-fuzzy techniques remove some of the shortcomings of ANN. They merge neural networks and fuzzy logic into an integrated system. ANFIS is one of the neuro-fuzzy systems with abilities such as learning potential and autoextraction of easily interpretable IF–THEN rules.

The obtained results confirmed the main hypothesis of the research (preference of the new data-driven techniques over traditional methods on missing flow data reconstruction). However, it can be seen that, although a large number of studies have been carried out and reported on the applications of ANN and ANFIS in hydrology, quite a few of them are related to the reconstruction of missing data of stream flow. Therefore, more investigations need to be completed on the application of the mentioned techniques in specific field to have a concrete statement.

References

Abebe, A. J., Solomatine, D. P., & Venneker, R. G. W. (2000). Application of adaptive fuzzy rule-based models for reconstruction of missing precipitation event. *Hydrological Sciences Journal*, 45(3), 425–436.

- Abraham, A., Köppen, M., & Franke, K. (2004). *Design and application of hybrid intelligent systems*. Amsterdam: IOS.
- Bhattacharya, B., & Solomatine, D. P. (2000). Application of artificial neural network in stage–discharge relationship. In *Proceedings of the 4th international conference on hydroinformatics*. Iowa City, USA.
- Dastorani, M. T., & Wright, N. G. (2002). Artificial neural network based real-time river flow prediction. In *Proceedings of the fifth international conference of hydrodynamics*. Cardiff, UK, 1–5 July
- Dastorani, M. T., & Wright, N. G. (2003). Flow estimation for ungauged catchments using a neural network method. In *Proceedings of the 6th international river engineering conference*. Ahwaz, Iran.
- Dastorani, M. T., & Wright, N. G. (2004). A hydrodynamic/neural network approach for enhanced river flow prediction. *International Journal of Civil Engineering*, 2(3), 141–148.
- Dawson, C. W., & Wilby, R. (1998a). An artificial neural network approach to rainfall-runoff modelling. *Journal of Hydrological Sciences*, 43(1), 47–66.
- Dawson, C. W., & Wilby, R. (1998b). A comparison of artificial neural network used for river flow forecasting. *Journal of Hydrology & Earth System Sciences*, 3(4), 529–540.
- Elshorbagy, A., Simonovic, S. P., & Panu, U. S. (2002). Estimation of missing stream flow data using principles of chaos theory. *Journal of Hydrology (Amsterdam)*, 255, 123–133. doi:10.1016/S0022-1694(01)00513-3.
- Hsu, K., Gupta, H. V., & Sorooshian, S. (1995). Artificial neural network modeling of the rainfall-runoff process. *Journal of Water Resources Research*, 31(10), 2517–2530. doi:10.1029/95WR01955.
- Jang, J. R. (1993). Adaptive network based fuzzy inference systems. *IEEE Transactions on Systems, Man, & Cybernetics*, 23, 665–685. doi:10.1109/21.256541.
- Karunanithi, N., Grenney, W. J., Whitley, D., & Bovee, K. (1994). Neural networks for flow prediction. *Journal of Computing in Civil Engineering*, 8(2), 201–220. doi:10.1061/(ASCE)0887-3801(1994)8:2(201).
- Kim, J., & Kasabov, N. (1999). ANFIS: adaptive neuro-fuzzy inference systems and their application to nonlinear dynamical systems. *Neural Networks*, 12, 1301–1319.
- Kurian, C. P., George, V. I., Bhat, J., & Aithal, R. S. (2006). ANFIS model for the time series prediction of interior daylight illuminance. *AIML Journal*, 6(3), 35–40.
- Linsley, R. K., Kohler, M. A., & Paulhus, J. L. H. (1988). *Hydrology for engineers*. Singapore: McGraw-Hill.
- Lucio, P. S., Conde, F. C., Cavalcanti, I. F. A., Serrano, A. I., Ramos, A. M., & Cardoso, A. O. (2007). Spatiotemporal monthly rainfall reconstruction via artificial neural network (case study: South Brazil). *Journal of Advances in Geosciences*, 10, 67–76
- Lughofer, E. (2003). *Online adaptation of Takagi-Sugeno fuzzy inference systems, technical report*. Linz-Hagenberg: Fuzzy Logic Laboratorium.
- Luk, K. C., Ball, J. E., & Sharma, A. (1998). Rainfall forecasting through artificial neural networks. In V. Babovic & L. C. Larsen (Eds.), *Hydroinformatics '98*. Rotterdam: Balkema.
- Minns, A. W., & Hall, M. J. (1996). Artificial neural networks as rainfall-runoff models. *Journal of Hydrological Sciences*, 41(3), 399–417.
- NeuroDimension. (2001). *NeuroSolutions*. Retrieved from <http://www.nd.com>.
- Rumelhart, D. E., Hinton, G. E., & Williams, R. J. (1986). Learning internal representations by back propagation. In D. E. Rumelhart, J. L. McClelland, & PDP Research Group (Eds.), *Parallel distributed processing*, (Vol. 1, pp. 318–362). Cambridge, MA: MIT.
- Tokar, S. A., & Johnson, P. A. (1999). Rainfall-runoff modeling using artificial neural networks. *Journal of Hydrologic Engineering*, 4(3), 232–239. doi:10.1061/(ASCE)1084-0699(1999)4:3(232).