

APPLICATION OF LINEAR AND NON-LINEAR  
GRAPHS IN STRUCTURAL SYNTHESIS  
OF KINEMATIC CHAINS

By

MATTHEW HUANG

Bachelor of Science  
Cheng-Kung University  
Tainan, Taiwan  
1964

Master of Science  
Oklahoma State University  
Stillwater, Oklahoma  
1968

Submitted to the Faculty of the Graduate College  
of the Oklahoma State University  
in partial fulfillment of the requirements  
for the Degree of  
DOCTOR OF PHILOSOPHY  
May, 1972

Thesis  
1972 D  
H8743a  
Cap. 2

AUG 10 1973

APPLICATION OF LINEAR AND NON-LINEAR  
GRAPHS IN STRUCTURAL SYNTHESIS  
OF KINEMATIC CHAINS

Thesis Approved:

*Armenam H. Soni*

Thesis Adviser

*Das yalagadda*

*Donald W. Grace*

*R L Lowery*

*N Durham*

Dean of the Graduate College

## ACKNOWLEDGMENTS

I would like to express my sincere appreciation to Dr. A. H. Soni, thesis adviser and chairman of my doctoral committee for his understanding, assistance and continuing encouragement during the course of this study. My thanks are also due to him for his help during my entire stay in Stillwater.

My gratitude is expressed to Dr. Lee Harrisberger, former chairman of my committee for his criticism and valuable suggestions; to Dr. Donald Grace for his counsel and constant encouragement; to Dr. Richard Lowery for his advise and assistance; to Dr. Rao Yarlagadda for his guidance and constructive suggestions.

I wish to thank the National Science Foundation for the financial support through research projects GK-2154 and GU-3160 which made this study possible.

My appreciation is expressed to my colleagues, Mr. Glenn Dewey, Mr. Rao Dukkupati, Mr. Dilip Kohli and Mr. Syed Hamid for their helpful discussions and companionship.

Mr. and Mrs. Joe E. Robinson are thanked for their host family's care during my entire stay in Stillwater and for the proof-reading of this dissertation.

My special gratitude is expressed to each member of my family for their understanding and moral support, especially to my wife, Becky, for her sacrifice, enduring encouragement and her typing of this dissertation.

## TABLE OF CONTENTS

Chapter	Page
I. INTRODUCTION . . . . .	1
II. A BRIEF REVIEW OF GRAPH THEORY AND POLYA'S THEORY OF COUNTING . . . . .	11
Definitions . . . . .	11
Incidence Matrices and Their Relations in Graph Isomorphism . . . . .	13
Permutation and Cycle Index . . . . .	22
Cycle Index of the Symmetrical Group. . . . .	24
Cycle Index of the Dihedral Group . . . . .	25
Cycle Index of the Full Pair Group. . . . .	28
Cycle Index of the Polyhedral Group . . . . .	29
Polya's Theory and Its Application . . . . .	34
III. SYNTHESIS OF LINEAR AND NON-LINEAR COLORED GRAPHS . . . . .	40
Specifications of Colored Graphs . . . . .	40
Synthesis of Vertex-Vertex Incidence Matrices . . . . .	44
Cut-Set Matrix with Modulo-2 Operation. . . . .	53
IV. ALGORITHM OF COLORED GRAPH ISOMORPHISM TEST . . . . .	58
Isomorphism Test for Linear and Non-Linear Colored Graphs. . . . .	60
V. COMPUTER METHODS OF LISTING SPECIFICATIONS, SYNTHESIZING INCIDENCE MATRICES AND TESTING ISOMORPHISM OF COLORED GRAPHS. . . . .	72
Listing of Colored Graph Specifications . . . . .	72
Synthesis of Vertex-Vertex Incidence Matrices. . . . .	73
Colored Graph Isomorphism Test. . . . .	74
VI. GRAPHICAL REPRESENTATIONS, MOBILITY EQUATIONS AND CRITERIA OF KINEMATIC CHAINS WITH DIFFERENT KINEMATIC ELEMENTS . . . . .	75
Cam Kinematic Chains. . . . .	76

Chapter	Page
Piston-Cylinder Kinematic Chains . . . . .	87
Prism Kinematic Chains . . . . .	91
Gear Kinematic Chains . . . . .	97
Spring Kinematic Chains . . . . .	101
Belt-Pulley Kinematic Chains . . . . .	102
Kinematic Chains with Combination of Different Kinematic Elements . . . . .	105
 VII. COLORED GRAPHS AND THEIR CORRESPONDING KINEMATIC CHAINS DEVELOPED FROM PARENT EIGHT LINK CHAIN . . . . .	     109
Colored Graphs and Kinematic Chains with One Kinematic Element . . . . .	111
Colored Graphs and Kinematic Chains with Two Kinematic Elements . . . . .	111
Colored Graphs and Kinematic Chains with Three Kinematic Elements . . . . .	112
 VIII. SUMMARY AND CONCLUSIONS . . . . .	 141
 BIBLIOGRAPHY . . . . .	 147
 APPENDIX A - KINEMATIC GRAPHS OF PARENT EIGHT LINK CHAINS . . . . .	  155
 APPENDIX B - COMPUTER PROGRAMS . . . . .	 158
 APPENDIX C - LISTING OF PRISM KINEMATIC CHAINS . . . . .	 191

LIST OF TABLES

Table	Page
I. The First Six Cycle Indices of Symmetrical Group, $C_n$ . . . . .	25
II. The Cycle Indices of Dihedral Group, $D_n(t_1, t_2, \dots, t_n)$ , $n = 3, 4, \dots, 7$ . . . . .	28
III. Procedures for Obtaining the Cycle Index of Full Pair Group, $R_4$ . . . . .	30
IV. All the Linear Graphs Having 4 Vertices . . . . .	36
V. Non-Linear Graphs Having 4 Vertices with Weights $y^5z$ , $xy^3z^2$ and $x^2yz^3$ . . . . .	38
VI. All the 6 Linear Graphs Having 5 Vertices and 6 Edges, Colored Graphs and CKC . . . . .	78
VII. One Linear Graph Having 4 Vertices, 5 Edges, Colored Graphs and CKC. . . . .	81
VIII. Non-Linear Graphs and CKC Developed from Parent 6 Link Chain . . . . .	82
IX. Non-Linear Graphs with 4 Vertices and 7 Edges . . . . .	84
X. CKC with 6 Cam Pairs Obtained from Table IX . . . . .	85
XI. Kinematic Chains with Different Number of Kinematic Elements. . . . .	110
XII. Colored Graphs and Kinematic Chains with One Kinematic Element. . . . .	113
XIII. Colored Graphs and Kinematic Chains with Two Kinematic Elements . . . . .	125
XIV. Colored Graphs and Kinematic Chains with Three Kinematic Elements . . . . .	139
XV. Sixteen Kinematic Graphs of Parent 8 Link Chains . . . . .	156

LIST OF FIGURES

Figure	Page
1. A Vertex-Edge Incidence Matrix and Its Corresponding Graph . . . . .	14
2. Two Non-Isomorphic Graph Having the Same Edge-Edge Incidence Matrix . . . . .	17
3. Non-Isomorphic Graphs (But Are Two-Isomorphic) Having the Same Loop-Edge Incidence Matrix. . . . .	18
4. Non-Isomorphic Graphs (But Are Two-Isomorphic) Having the Same Loop-Vertex Incidence Matrix. . . . .	19
5. Pentagon and Its Axes of Symmetry . . . . .	26
6. A Pyramid and Its Axis of Rotation. . . . .	32
7. A Cube and Its Axes of Rotation . . . . .	32
8. Two One-Colored Graphs Having the Same Specification But Are Not Isomorphic. . . . .	42
9. Two Two-Colored Graphs Having the Same Specification But Are Not Isomorphic. . . . .	42
10. A Non-Linear Two-Colored Graph. . . . .	43
11. A Linear Two-Colored Graph. . . . .	45
12. Four V-V Incidence Matrices and Their Corresponding Graphs Obtained from [332222] . . . . .	50
13. Subgraphs and 2-Colored Graphs Obtained from $\begin{pmatrix} 1212 \\ 2110 \end{pmatrix}$ . . . . .	52
14. Graph and Its Cut-Sets . . . . .	54
15. Graphs with Complete Set of Trees . . . . .	57
16. Two Linear Two-Colored Graphs . . . . .	65



Figure	Page
17. Two Non-Linear Three-Colored Graphs . . . . .	70
18. Watt's Six Link Chain and Its Corresponding Graph . . . . .	76
19. CKC with One Cam Pair and Its Colored Graph . . . . .	76
20. Parent Kinematic Chain and Piston-Cylinder Kinematic Chain (PKC) . . . . .	88
21. Graphical Representations of Parent Kinematic Chain and PKC . . . . .	88
22. Relationship Between Colored Graphs of CKC and PKC . . . . .	90
23. Prism Kinematic Chains ( $P_r$ KC) . . . . .	92
24. Graphical Representation of $P_r$ KC . . . . .	93
25. $P_r$ KC against Rule 7 . . . . .	94
26. $P_r$ KC against Rule 8 . . . . .	95
27. $P_r$ KC against Rule 9 . . . . .	96
28. A CKC and Its Colored Graph . . . . .	97
29. A CKC Becomes a Gear Kinematic Chain (GKC) . . . . .	98
30. Schematic and Graphical Representation of GKC . . . . .	99
31. A Colored Graph and Its Paradoxical GKC . . . . .	100
32. Parent Four Link Chain, SKC and Its Colored Graph . . . . .	102
33. Parent Six Link Chain, BKC and Its Colored Graph . . . . .	103
34. A Colored Graph and Its Corresponding Kinematic Chain . . . . .	107

## CHAPTER I

### INTRODUCTION

The process of structural synthesis is a systematic rational approach. A great deal of work has been done to undertake the task of structural analysis and synthesis in the fields of electrical networks, chemistry, transportation systems, social sciences and other related fields [1,2,3,4,5,6]<sup>1</sup>.

Using the analogy of the symbolic notations of chemistry, Reuleaux in 1876 [7] attempted to develop a symbolic representation for kinematic chains. His objectives were to devise a vocabulary of symbols to describe a particular combination of kinematic components. A link and a fixed link are represented by a solid line and two parallel lines respectively. The kinematic elements, which are defined by their geometrical form and their kinematic function, are represented by 15 capital letters, for example, S is for screw, P for prism, C for cylinder, R for turning joint. The superscripts + and - after these letters indicated the male and the female component forms of a kinematic pair. Although his symbolic representation for kinematic chains serves to illustrate many kinematic relationships, it has not proved generally applicable due to its inconvenience in use.

---

<sup>1</sup>Numbers in brackets denote the references given in the Bibliography.

Recently, Franke [8,9] contributed to an alternate symbolic notation of kinematic chains. In contrast to Reuleaux's approach, the joints of a chain are only the elements of mechanisms themselves. For example, a single joint chain is represented by E, a two-joint chain by Z, a three-joint chain by D, and a four-joint chain by V. Small subscript letters are also used, for example, d denotes a turning joint and s a sliding joint.

Davies and Crossley [10] applied these Franke's condensed notations to chains in which a link is represented by a molecule and a joint connection by a line segment. They obtained the structural enumeration of seven, nine and eleven-link kinematic chains. This work represents the first application of Franke's notation to the structural analysis of kinematic chains.

During the period around 1930, Alt [11], Gruebler [12,13,14], Malytcheff [15] and Kutzbach [16,17,18] were concerned with the theoretical approach to the determination of the degree of mobility of the planar and spatial kinematic chains. Later in 1950's, Artobolevski [19] and Dobrovolski [20] took into account the existence of the paradoxical mechanisms and introduced the concept of the general constraints.

Soni [21] applied the Franke's condensed notation and concept of general constraint to analyze the two-loop (8- and 9- links) and three-loop (11- and 12- links) kinematic chains which have two general constraints and mobilities one and two. All the kinematic chains considered by Soni consist of helical pairs with parallel axes and random pitch values.

Hain and Zielstorff [22] analyzed the sixteen parent 8-link

kinematic chains (see Appendix A) and tabulated all the seventy-one mechanisms derived from 8-link chains. A systematic analysis by them shows that these sixteen 8-link chains with single pair yield additional forty-four 8-link chains with multiple pairs. Kinematic inversions from these forty-four chains yield 264 mechanisms with 'double joints' and 'triple joints'.

Assur [23,24] developed different groups of various open chains which would express the characteristics and the forms of kinematic chains. Manolescu, Haas and Crossley [25,26] used the Assur group to classify and study the general formula, functions and the practical applications of kinematic chains and mechanisms. Davies [27,28] extended Manolescu's classification of planar mechanisms to the mechanisms of mobility  $M > 1$ . The mobilities of the kinematic chain and its subchains are studied in terms of total and partial mobilities.

Using the number synthesis technique and the general mobility equation, Harrisberger and Soni [29,30] explored 417 and 212 kinds respectively of one-loop space kinematic chains with zero and one general constraint. They suggested the classification of kinematic pairs by their number of degrees of freedom. There are five classes of kinematic pairs as the pair can have the maximum of five and minimum of one degree of freedom.

Woo [31] applied the concepts of "contraction map" and enumerated the 10-link kinematic chains. The results found by Woo, coupled with those by Davies and Crossley [10] do confirm that the number of 10-link plane kinematic chains is 230.

Since the basic schematic representations used by both Woo and Davies [31,10] are the same, the approaches used by both authors have

two points in common: (a) The enumeration of all possible arrangements of molecules or contraction maps without considering binary links and (b) The enumeration of the number of ways of adding the binary links to those arrangements.

From the graph-theoretic point, Crossley [32] analyzed the kinematic chains of eight members or less. Since the links and turning joints of a kinematic chain are represented by vertices and edges in a graph, the graph shows the kinematic chain as a function of topology of the components. Therefore, many properties of the kinematic chain can be studied precisely using graph theory.

Following the works done by Harrisberger and Soni [29,30], Freudenstein and Dobrjanskyj [33,34,35] applied the concepts of graph theory and combinatorial method to enumerate the single loop spatial kinematic chains and mechanisms with lower kinematic pairs. It is shown that the number of single loop spatial kinematic chains with different kinematic pairs is equal to the coefficient of the weight function in the expansion of the cycle index of the dihedral group. In these works, no attempt is made to include mechanisms with passive constraints or to exclude the unworkable combinations.

The problems of kinematic synthesis which are discussed above can be divided into two categories:

- (1) Synthesis of plane kinematic chains with turning joints and rigid links only. The methods used are: Franke's notation and contraction map [10,21,23,24,25,26,31].
- (2) Synthesis of single loop space kinematic chains with different kinematic pairs. The methods used are: number synthesis technique and graph theory [29,30,33,34,35].

From the two parent 6-link chains, Hain [36] obtained 158 cam-linkage mechanisms with one, two, three cam pairs and single and double joints. In his tables, the cam pair in cam linkage mechanism is the contact of one cam and one roller rather than the contact of two cams.

Replacing a turning pair by a prism pair, Hain [37] derived six six-link chains with one prism pair from Watt's and Stephenson's six-link chains. Hain also obtained 54 different screw-crank mechanisms with single and double joints by replacing the prism pair by a screw joint. Later in 1968, Hain [38] derived all the six-link kinematic chains with more than one prism pairs. There are 50 prism kinematic chains with a maximum of four prism pairs and single joint and 28 prism kinematic chains with a maximum of four prism pairs and double joints.

Based on the information of prism kinematic chains, the piston-cylinder kinematic chains with one piston-cylinder were developed by Hain [39] from the two 6-link chains. Four piston-cylinder kinematic chains with one piston-cylinder were obtained which yield eight piston-cylinder mechanisms. Hain also displayed seven six-link double piston mechanisms in which two pistons are in one cylinder.

From the two six-link chains, eight different belt-pulley mechanisms are derived by Hain [40]. Hain also demonstrated that the belt-pulley mechanism can be transformed into an equivalent rolling-contact (cam) mechanism such that both belt-pulley mechanism and cam mechanism have exactly the same relative motions.

Thirteen spring kinematic chains with single and double joints were derived by Hain [41] from four- and six-link chains.

The procedures to derive belt-pulley and spring mechanisms are combined by Hain [42] to produce a total of 16 different spring-belt

mechanisms.

Besides, Hain [43] derived five gear-crank mechanisms with prism pairs from a five-link chain and two gears. Five chain-crank mechanisms derived from four-link chain were also obtained by Hain [44].

Hain's work is more or less restricted to inspection process and does not depend on the mathematical theories. The process becomes more involved especially when it is required to enumerate kinematic chains and mechanisms with more than six links.

Johnson and Towfigh [45] applied the number synthesis techniques to design the gear kinematic chains. Levai [46], Benford [47], Tuplin [48], Spotts [49] and Chironis [50] also used the numerical rules to design the various gear kinematic chains.

Using graph theory and synthesis procedures, Buchsbaum [51,52] investigated the structural classification and enumeration of gear kinematic chains with a maximum of 3 gear joints (commonly known as gear trains, speed reducers or differentials). The enumeration of gear kinematic chains is shown to be equivalent to the enumeration of geometric structures, that is, linear 2-colored graphs. Besides the technique of Polya's theory of counting [53,54] which is used to establish the completeness of enumeration procedure, Bushsbaum also presented two basic algorithms to show the local degree listing and the synthesis of vertex-vertex (v-v) incidence matrices for linear one-colored graph.

The latest work by Quist [55] includes the enumeration of 10 link chains with kinematic elements such as cam pairs, prism pairs, spring pairs and belt-pulleys. The method Quist used is called "path matrix" in which the links of a given kinematic chain are labelled with different numbers, the row of "path matrix" is formed by writing the sequence

numbers of each circuit in the kinematic chain. Unlike the mathematical approach based on graph theory, Quist's enumeration technique has to rely on a given list of parent kinematic chains and the method of "path matrix" becomes 'trial and error' for crossed-link kinematic chains.

Therefore, two more categories concerned with kinematic synthesis can be summarized as follows:

- (3) Synthesis of plane kinematic chains with different kinematic elements other than turning joints, such as cam pairs, prism pairs, piston-cylinders, springs and belt-pulleys [36-44,55]. The methods used are: inspection process and "path matrix".
- (4) Synthesis of gear kinematic chains [45-50,51,52] (linear 2-colored graphs). The methods used are: number synthesis, graph theory and enumeration techniques.

The purpose of this study is to develop procedures to apply graph theory to the general problems of synthesizing kinematic chains with different kinematic elements and their combinations. The kinematic elements under consideration are cam pairs, prism pairs, piston-cylinders, gears, springs and belt-pulleys.

All the graphical representations for the kinematic chains with different kinematic elements have been systematically established. The kinematic chains are represented in the form of linear or non-linear multicolored graphs in which colored edges and/or colored vertices correspond to certain types of kinematic elements.

Using the general mathematical theories, three major general algorithms are developed which take into account the whole process of synthesizing the multicolored graphs. Computer programs describing the



three algorithms are developed. They are listed in Appendix B.

The first algorithm generates a list of specification for  $n$ -colored graph. The specification is expressed in terms of the sets of degrees of vertices of  $n$  subgraph. A general computer program has been developed to generate the listing of colored graph specifications. The given conditions are the numbers of vertices and edges of a graph. The lower and the upper bounds of the specifications can also be specified.

The listing of specifications only provides the information about the numbers of ways of combining the degrees of vertices of a graph. It does not provide any information about the connections of the vertices. Therefore, the second algorithm is developed to synthesize the linear and the non-linear colored graphs from a given specification.

The synthesis of  $v$ - $v$  incidence matrices of  $n$ -colored graphs can be accomplished by considering each subgraph (graph with same type of edges) specification individually. For each subgraph specification, the corresponding  $v$ - $v$  incidence matrices can be synthesized. All the possible superpositions of the elements in the  $v$ - $v$  incidence matrices of  $n$  subgraphs become the final  $v$ - $v$  incidence matrices obtained for the given  $n$ -colored graph specification.

A general computer program has been developed to synthesize the  $v$ - $v$  incidence matrices of  $n$ -colored graphs. The program is written in such a way that it can take care of any number of types of colored edges and any number of vertices.

Since not all  $v$ - $v$  incidence matrices of  $n$ -colored graphs synthesized are non-isomorphic, they have to go through the process of graph isomorphism test. The isomorphism test is then the third algorithm to be described. Due to the necessity of the problems defined in this

study, the writer has developed a general algorithm to test the isomorphism of a pair of linear or non-linear  $n$ -colored graphs. The method of incidence tables is used and the total number of possibilities of finding the graph isomorphism is described. A general computer program is developed to take into account any number of colored vertices and colored edges in the linear or non-linear colored graphs.

Given the number of links and turning joints of a parent kinematic chain and different kinematic elements, all the unequivalent kinematic chains with different kinematic elements (or colored graphs) can be synthesized by going through the whole process of the three algorithms described above.

In order to establish the completeness of the enumeration, Polya's theory of counting has been used. It provides the exact count of the total number of graphs which should be generated for a given number of vertices and edges. Chapter II is mainly concerned with the application of the Polya's theory of counting. Some illustrative examples are given.

Since not all colored graphs synthesized generate the closed and isokinetic chains [32], the criteria are developed to reject those unacceptable colored graphs.

General mobility equations in terms of colored vertices and colored edges are developed for kinematic chains with different kinematic elements. These mobility equations are useful not only in examining the mobility of the kinematic chains, but also in solving the sets of numbers of colored vertices and colored edges required in synthesizing colored graphs.

In Chapter VII, the general model is tested on eight link chains

to generate all the colored graphs and their corresponding kinematic chains with all possible kinematic pairs and elements.

In summary, the objectives of the present investigation are:

1. To obtain the graphical representations for the kinematic chains with different kinematic elements and their combinations. The kinematic elements under consideration are cam pairs, prism pairs, piston-cylinders, gears, springs and belt-pulleys.
2. To develop a general mathematical model to take into account the synthesis procedures of linear and non-linear n-colored graphs.
3. To develop the general computer programs for the mathematical model which include the programs of listing colored graph specifications, synthesizing v-v incidence matrices of linear and non-linear n-colored graphs and testing isomorphism for linear and non-linear n-colored graphs.
4. To derive the general mobility equations and criteria for the various kinematic chains under consideration.
5. To obtain the design tables for the colored graphs and their corresponding kinematic chains developed from parent 8 link and 10 joint chains.

## CHAPTER II

### A BRIEF REVIEW OF GRAPH THEORY AND POLYA'S THEORY OF COUNTING

The necessary mathematical background is introduced and followed by some examples to illustrate the applications of the mathematical techniques. Some of the techniques concerning the combinatorial analysis, such as partitioning, combinations are described in related chapters and are implemented as subroutines in the programs shown in Appendix B. The mathematical proofs for the techniques introduced in this chapter are available in the literature [34,35,53,54,56,57].

#### Definitions

Some of the definitions of graph theory used in this study are described below:

1. Vertex: An endpoint of an edge.
2. Edge: A line segment terminated by distinct end points.
3. Graph: A collection of vertices and edges.
4. Linear graph: A graph which has no slings (or self-loops) or multiple-edges.
5. Non-linear graph: A graph which has slings and/or multiple-edges.
6. Sling: Self-loop or a loop connecting a vertex to itself.
7. Multiple-edge: The subgraph of a non-linear graph in which two or more edges appear between two vertices.
8. Double-edge: A multiple-edge with exactly two edges between two

- vertices.
9. Complete graph: A graph in which every pair of distinct vertices are joined by an edge.
  10. Planar graph: A graph which can be drawn in the plane in such a way that its edges intersect only at their endpoints.
  11. Non-planar graph: A graph in which not all the edges can be drawn on a plane without crossing.
  - ✓ 12. Path: A sequence of line segments of a graph such that the terminal vertex of each line segment coincides with the initial vertex of the succeeding line segment.
  13. Connected graph: A graph in which there exists at least one path between every pair of vertices.
  14. Separable graph: A connected graph in which there exists a pair of vertices  $V_j$  and  $V_k$  ( $j \neq k$ ) such that all possible paths between these two vertices have one vertex (point of articulation)  $V_i$  ( $i \neq j \neq k$ ) in common.
  15. Non-separable graph: A connected graph in which there exists at least two distinct paths between any two of its vertices.
  16. Incidence: If a vertex is an endpoint of an edge, then the vertex and the edge are said to be incident.
  17. Degree of vertex: The number of edges incident at that vertex.
  18. Contracted graph (or Contraction map): A graph in which all the vertices of degree two are deleted.
  19. Isomorphism: Graphs  $G_1=(V_1,E_1)$  and  $G_2=(V_2,E_2)$  are said to be isomorphic to each other if there exists 1-1 correspondence between  $V_1$  and  $V_2$  and between  $E_1$  and  $E_2$  which preserve incidences.
  20. Colored graph: A graph in which vertices and/or edges are

- distinguished from each other.
21. Circuit (or Loop): A cyclic path from any vertex point  $a$  through other vertices returning to  $a$ , in which no vertex is visited more than once.
  22. 2-isomorphism: Two graphs  $G_1$  and  $G_2$  are 2-isomorphic if they become isomorphic under (repeated application of) either or both of the following operations:
    - a. Separation into components;
    - b. Interchange of the names of two subgraphs (let the graph consist of two subgraphs  $H_1$  and  $H_2$  which have only two vertices in common).
  23. Tree: A connected subgraph of a connected graph which contains all the vertices of the graph but does not contain any circuits.

#### Incidence Matrices and Their Relations in Graph Isomorphism

Let an incidence number  $P$  be the number of times a certain edge (or loop) is incident to a given vertex (or edge). The incidence number  $P$  is usually 1 or 0, as the designated pair is, or is not incident. For instance, incidence number  $P(v_i, e_j) = 1$  or 0 as vertex  $v_i$  is, or is not incident with edge  $e_j$ . Moreover,  $P(v_i, e_j)$  can be equal to 2, if  $e_j$  is a double-edge. Similarly,  $P(l_i, e_j) = 1$  or 0 as edge  $e_j$  is, or is not an element of loop  $l_i$ .

An incidence matrix can now be formed by writing the mathematical array of incidence numbers which precisely describes a given graph. A vertex-edge incidence matrix  $[M_{ve}]$  of  $v$  rows and  $e$  columns is an array of incidence numbers  $P(v, e)$ , in which each column represents a

specific edge and each row represents a specific vertex (Fig. 1).

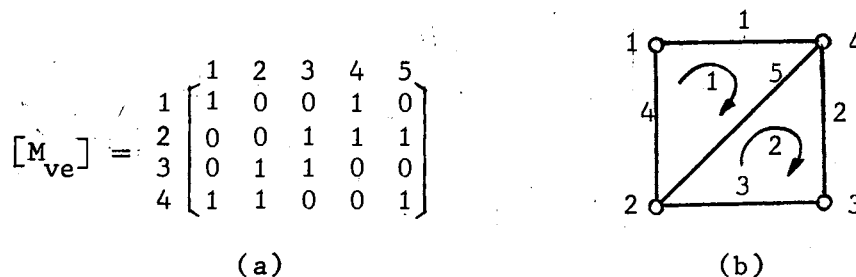


Figure 1. A Vertex-Edge Incidence Matrix and its Corresponding Graph

The other incidence matrices are arranged in similar manner. Vertex-vertex incidence matrix  $[M_{vv}]$  of  $v$  rows and  $v$  columns is a square matrix in which the entry is one if the two vertices have an edge in common, otherwise, the entry is zero. Loop-edge incidence matrix  $[M_{le}]$  of  $l$  rows and  $e$  columns is the rectangular matrix in which the entries are 1 or 0 as the edges are or are not the elements of a specific loop. Loop-vertex incidence matrix  $[M_{lv}]$  of  $l$  rows and  $v$  columns is also a rectangular matrix in which the entries are 1 or 0 as a specific loop does or does not pass through the vertices.

The five different incidence matrices described above are not independent of each other. According to the modulo-2 operation [3] and the ordinary algebraic operation, we may transform the incidence matrices from one to another. Four equations which relate the incidence matrices are shown in Eq. (2-1) through Eq. (2-4). The superscript T refers to the transpose of a matrix.

$$[M_{\ell e}] [M_{ve}]^T = 0 \quad (2-1)$$

$$[M_{ee}] = [M_{ve}]^T [M_{ve}] \quad (2-2)$$

$$[M_{vv}] = [M_{ve}] [M_{ve}]^T \quad (2-3)$$

$$[M_{\ell v}] = (1/2) [M_{\ell e}] \times [M_{ve}]^T \quad (2-4)$$

It should be noted that Eqs. (2-1), (2-2) and (2-3) are to be carried out by modulo-2 operation, while Eq. (2-4) is to be carried out by ordinary algebraic operation.

Example 2-1 Express and verify the relationships of Eq. (2-1) through Eq. (2-4) for the graph shown in Fig. 1(b).

Solution:

$$[M_{ve}] = \begin{pmatrix} 1 & 0 & 0 & 1 & 0 \\ 0 & 0 & 1 & 1 & 1 \\ 0 & 1 & 1 & 0 & 0 \\ 1 & 1 & 0 & 0 & 1 \end{pmatrix} \quad [M_{\ell e}] = \begin{pmatrix} 1 & 0 & 0 & 1 & 1 \\ 0 & 1 & 1 & 0 & 1 \end{pmatrix}$$

(1) For Eq. (2-1):

$$[M_{\ell e}] [M_{ve}]^T = \begin{pmatrix} 1 & 0 & 0 & 1 & 1 \\ 0 & 1 & 1 & 0 & 1 \end{pmatrix} \begin{pmatrix} 1 & 0 & 0 & 1 \\ 0 & 0 & 1 & 1 \\ 0 & 1 & 1 & 0 \\ 1 & 1 & 0 & 0 \\ 0 & 1 & 0 & 1 \end{pmatrix} = \begin{pmatrix} 0 & 0 & 0 & 0 \\ 0 & 0 & 0 & 0 \end{pmatrix} = 0$$

(2) For Eq. (2-2):

$$[M_{ve}]^T [M_{ve}] = \begin{pmatrix} 1 & 0 & 0 & 1 \\ 0 & 0 & 1 & 1 \\ 0 & 1 & 1 & 0 \\ 1 & 1 & 0 & 0 \\ 0 & 1 & 0 & 1 \end{pmatrix} \begin{pmatrix} 1 & 0 & 0 & 1 & 0 \\ 0 & 0 & 1 & 1 & 1 \\ 0 & 1 & 1 & 0 & 0 \\ 1 & 1 & 0 & 0 & 1 \end{pmatrix} = \begin{pmatrix} 0 & 1 & 0 & 1 & 1 \\ 1 & 0 & 1 & 0 & 1 \\ 0 & 1 & 0 & 1 & 1 \\ 1 & 0 & 1 & 0 & 1 \\ 1 & 1 & 1 & 1 & 0 \end{pmatrix}$$

$$= [M_{ee}]$$



(3) For Eq. (2-3):

$$\begin{aligned}
 [M_{ve}] [M_{ve}]^T &= \begin{pmatrix} 1 & 0 & 0 & 1 & 0 \\ 0 & 0 & 1 & 1 & 1 \\ 0 & 1 & 1 & 0 & 0 \\ 1 & 1 & 0 & 0 & 1 \end{pmatrix} \begin{pmatrix} 1 & 0 & 0 & 1 \\ 0 & 0 & 1 & 1 \\ 0 & 1 & 1 & 0 \\ 1 & 1 & 0 & 0 \\ 0 & 1 & 0 & 1 \end{pmatrix} = \begin{pmatrix} 0 & 1 & 0 & 1 \\ 1 & 1 & 1 & 1 \\ 0 & 1 & 0 & 1 \\ 1 & 1 & 1 & 1 \end{pmatrix} \\
 &= \begin{pmatrix} 0 & 1 & 0 & 1 \\ 1 & 0 & 1 & 1 \\ 0 & 1 & 0 & 1 \\ 1 & 1 & 1 & 0 \end{pmatrix} = [M_{vv}]
 \end{aligned}$$

It should be noted that the diagonal entries of  $[M_{vv}]$  should be equal to zeros. 0 or 1 on diagonal entry only means that the degree of vertex is either even or odd.

(4) For Eq. (2-4):

$$\begin{aligned}
 (1/2) [M_{le}] \times [M_{ve}]^T &= (1/2) \begin{pmatrix} 1 & 0 & 0 & 1 & 1 \\ 0 & 1 & 1 & 0 & 1 \end{pmatrix} \times \begin{pmatrix} 1 & 0 & 0 & 1 \\ 0 & 0 & 1 & 1 \\ 0 & 1 & 1 & 0 \\ 1 & 1 & 0 & 0 \\ 0 & 1 & 0 & 1 \end{pmatrix} \\
 &= (1/2) \begin{pmatrix} 2 & 2 & 0 & 2 \\ 0 & 2 & 2 & 2 \end{pmatrix} = \begin{pmatrix} 1 & 1 & 0 & 1 \\ 0 & 1 & 1 & 1 \end{pmatrix} = [M_{lv}]
 \end{aligned}$$

Two incidence matrices are equivalent, if they are different only by permutations of rows and columns. Two graphs are isomorphic if there exists 1-1 correspondence between their vertices and edges, and the incidences are preserved. Since vertices and edges are involved in the definition of isomorphism, the vertex-edge incidence matrix is usually used in the graph isomorphism test. Therefore, two graphs are isomorphic, if their vertex-edge incidence matrices are equivalent. It should be noted that vertex-vertex incidence matrix can be converted directly into vertex-edge incidence matrix. The number of non-zero entries in the upper triangle of vertex-vertex

incidence matrix are the number of edges or number of columns in vertex-edge incidence matrix.

If the vertex-edge incidence matrices of two graphs are equivalent, the graphs are isomorphic [35]. However, if the edge-edge or loop-edge or loop-vertex incidence matrices of two graphs are equivalent, these facts do not guarantee that the two graphs are isomorphic.

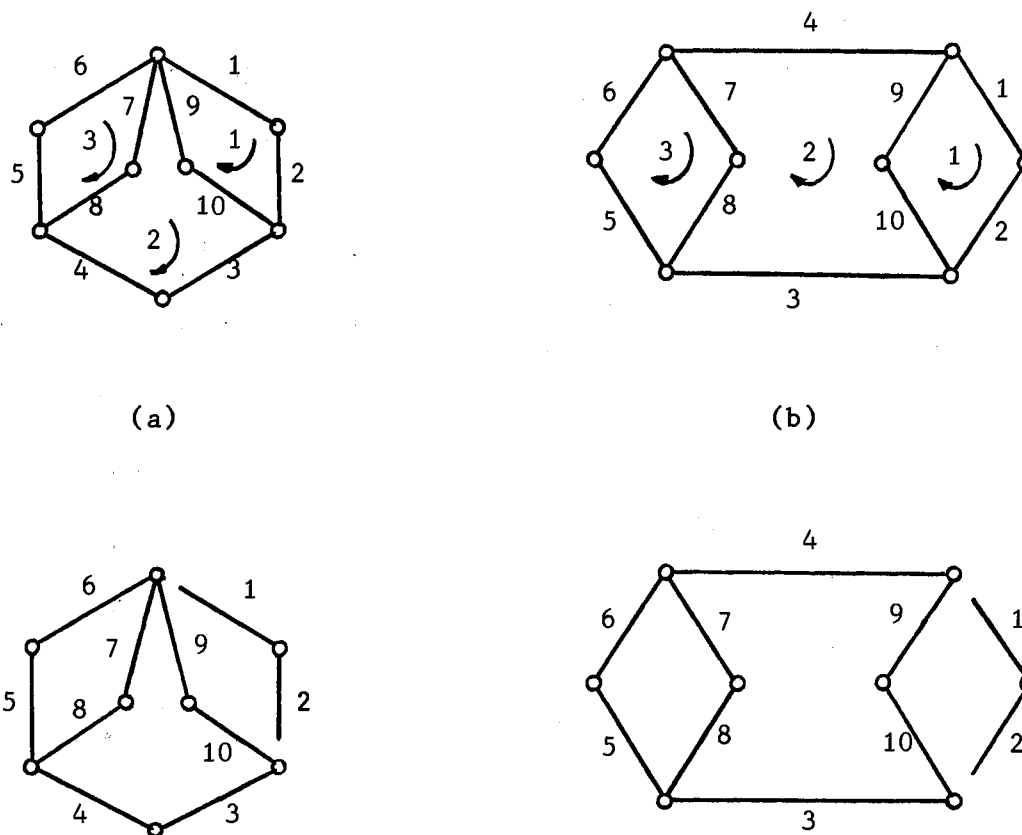
Fig. 2 shows two graphs whose edge-edge incidence matrices are the same, but which are not isomorphic. According to Whitney [58,59], this is one of a very few exceptions.



$$[M_{ee}^1] = \begin{matrix} & \begin{matrix} 1 & 2 & 3 \end{matrix} \\ \begin{matrix} 1 \\ 2 \\ 3 \end{matrix} & \begin{bmatrix} 0 & 1 & 1 \\ 1 & 0 & 1 \\ 1 & 1 & 0 \end{bmatrix} \end{matrix} = [M_{ee}^2]$$

Figure 2. Two Non-Isomorphic Graphs Having the Same Edge-Edge Incidence Matrix

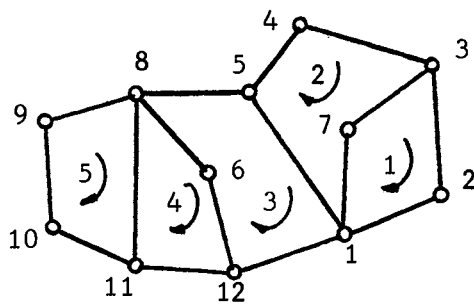
Fig. 3 shows two non-isomorphic graphs whose loop-edge incidence matrices are the same. These graphs are for the parent 8 link, 10 joint kinematic chains. The two non-isomorphic graphs in Fig. 3 are two-isomorphic, that is, they become isomorphic under the operation of separation into components.



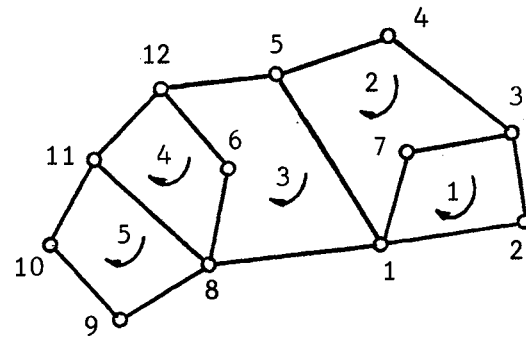
$$[M_{le}^1] = \begin{bmatrix} 1 & 1 & 0 & 0 & 0 & 0 & 0 & 0 & 1 & 1 \\ 0 & 0 & 1 & 1 & 0 & 0 & 1 & 1 & 1 & 1 \\ 0 & 0 & 0 & 0 & 1 & 1 & 1 & 1 & 0 & 0 \end{bmatrix} = [M_{le}^2]$$

Figure 3. Non-Isomorphic Graphs (But Are Two-Isomorphic) Having the Same Loop-Edge Incidence Matrix

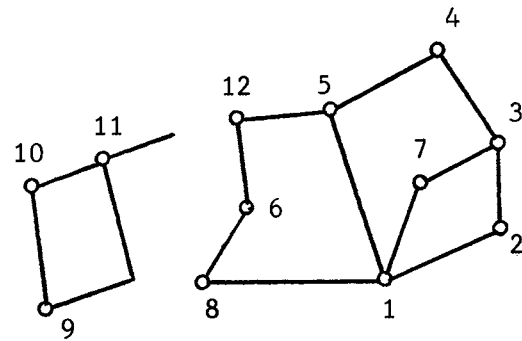
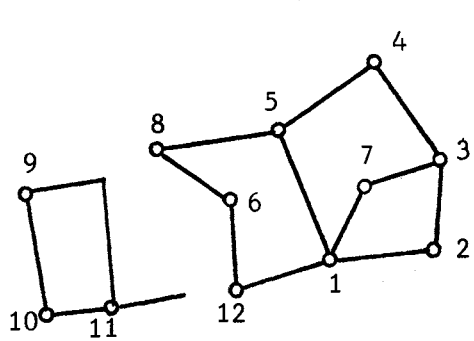
Fig. 4 shows two non-isomorphic graphs having the same loop-vertex incidence matrix. They are also two-isomorphic [35].



(a)



(b)



$$[M_{lv}^1] = \begin{pmatrix} 1 & 1 & 1 & 0 & 0 & 0 & 1 & 0 & 0 & 0 & 0 & 0 \\ 1 & 0 & 1 & 1 & 1 & 0 & 1 & 0 & 0 & 0 & 0 & 0 \\ 1 & 0 & 0 & 0 & 1 & 1 & 0 & 1 & 0 & 0 & 0 & 1 \\ 0 & 0 & 0 & 0 & 0 & 1 & 0 & 1 & 0 & 0 & 1 & 1 \\ 0 & 0 & 0 & 0 & 0 & 0 & 0 & 1 & 1 & 1 & 1 & 0 \end{pmatrix} = [M_{lv}^2]$$

Figure 4. Non-Isomorphic Graphs (But Are Two-Isomorphic) Having the Same Loop-Vertex Incidence Matrix

The concepts of two-isomorphism are concerned with the relations of loops and edges, or loops and vertices. Therefore, two-isomorphism does not necessarily preserve incidences between loops, edges and vertices. Isomorphic graphs are also two-isomorphic, but the converse is not necessarily true. From the above examples, we know that edge-edge, loop-edge and loop-vertex incidence matrices are not sufficient to uniquely describe a graph.

If two graphs are isomorphic, then their vertex-edge incidence matrices are related by Eq. (2-5).

$$[M_{ve}^1] = [E_v] [M_{ve}^2] [E_e] \quad (2-5)$$

where

$[M_{ve}^1]$ : Vertex-edge incidence matrix of graph 1.

$[M_{ve}^2]$ : Vertex-edge incidence matrix of graph 2.

$[E_v]$ : Vertex elementary matrix which transforms the vertices in graph 1 and graph 2.

$[E_e]$ : Edge elementary matrix which transforms the edges in graph 2 and graph 1.

From Eq. (2-2), we can derive an equation which relates the edge-edge incidence matrices of two isomorphic graphs,  $[M_{ee}^1]$  and  $[M_{ee}^2]$ :

$$\begin{aligned} [M_{ee}^1] &= [M_{ve}^1]^T [M_{ve}^1] = [E_e]^T [M_{ve}^2]^T [E_v]^T [E_v] [M_{ve}^2] [E_e] \\ &= [E_e]^T [M_{ve}^2]^T [I] [M_{ve}^2] [E_e] = [E_e]^T [M_{ee}^2] [E_e] . \end{aligned}$$

$$\text{Therefore, } [M_{ee}^1] = [E_e]^T [M_{ee}^2] [E_e] \quad (2-6)$$

Similarly, the equation relating the vertex-vertex incidence matrices of two isomorphic graphs can be derived from Eq. (2-3):

$$\begin{aligned} [M_{vv}^1] &= [M_{ve}^1] [M_{ve}^1]^T \\ &= [E_v] [M_{ve}^2] [E_e] [E_e]^T [M_{ve}^2]^T [E_v]^T \\ &= [E_v] [M_{ve}^2] [M_{ve}^2]^T [E_v]^T \\ &= [E_v] [M_{vv}^2] [E_v]^T \end{aligned}$$

$$\text{Therefore, } [M_{vv}^1] = [E_v] [M_{vv}^2] [E_v]^T \quad (2-7)$$

Since loops and edges of two isomorphic graphs are in one-to-one correspondence and preserve adjacency, therefore,

$$[M_{le}^1] = [E_l] [M_{le}^2] [E_e] \quad (2-8)$$

Here  $[E_l]$  is the loop elementary matrix which transforms the loops in graph 1 and graph 2. From Eq. (2-4), the relation of loop-vertex incidence matrices of two isomorphic graphs can be derived:

$$\begin{aligned} [M_{lv}^1] &= (1/2) [M_{le}^1] \times [M_{ve}^1]^T \\ &= (1/2) [E_l] [M_{le}^2] [E_e] \times [E_e]^T [M_{ve}^2]^T [E_v]^T \end{aligned}$$

$$\text{Since } [M_{le}^2] [E_e] \times [E_e]^T [M_{ve}^2]^T = [M_{le}^2] \times [M_{ve}^2]^T$$

$[M_{lv}^1]$  can be written as

$$\begin{aligned} [M_{lv}^1] &= [E_l] (1/2) [M_{le}^2] \times [M_{ve}^2]^T [E_v]^T \\ &= [E_l] [M_{lv}^2] [E_v]^T \end{aligned}$$

and therefore,  $[M_{lv}^1] = [E_l] [M_{lv}^2] [E_v]^T$  (2-9)

The derivation of Eq. (2-9) is carried out by the ordinary algebraic operation, while the derivations for Eqs. (2-6), (2-7) and (2-8) are carried out by modulo-2 operation [3].

#### Permutation and Cycle Index

A sequence can be mapped into another sequence by a set of transformations. The set of these transformations is called permutation. For example, a sequence (a,b,c,d,e,f) is mapped into another sequence (b,d,f,a,e,c) by the following transformations.

Permutation group:

$$\begin{pmatrix} a & b & c & d & e & f \\ b & d & f & a & e & c \end{pmatrix}$$

Transformation:

$$(1) \quad a \rightarrow b \rightarrow d \rightarrow a$$

$$(2) \quad c \rightarrow f \rightarrow c$$

$$(3) \quad e \rightarrow e$$

The above transformation or permutation of the sequence is represented by the cyclic representation (abd) (cf) (e). The permutation (abd) (cf) (e) consists of three cycles: (abd), (cf) and (e). The length of a cycle is the number of elements it contains. Therefore, in this permutation, the lengths of the three cycles are 3,2,1 respectively. The type of a permutation is the product  $\prod t_i^j$  for all cycles

of the permutation.  $t_i$  is the representation of a cycle with length  $i$ .  $j$  is the number of cycles with  $t_i$ . For the above permutation group, the permutation  $(abd)(cf)(e)$  can be represented by the type  $t_3 t_2 t_1$ .

The cycle index of a permutation group is defined as the summation of the types of all permutations, divided by the number of permutations or order of the permutation group [53,54].

Example 2-2 Let  $a, b, c$  be the elements in a sequence  $(a, b, c)$ . Find the cycle index of the group with all possible permutations.

Solution: A table prepared to show the permutations, cyclic representations and their corresponding types is shown below.

Permutation	Cyclic representation of permutation	Type
1: $(a, b, c) \rightarrow (a, b, c)$	$(a)(b)(c)$	$t_1^3$
2: $(a, b, c) \rightarrow (a, c, b)$	$(a)(bc)$	$t_1 t_2$
3: $(a, b, c) \rightarrow (b, a, c)$	$(ab)(c)$	$t_1 t_2$
4: $(a, b, c) \rightarrow (b, c, a)$	$(abc)$	$t_3$
5: $(a, b, c) \rightarrow (c, a, b)$	$(acb)$	$t_3$
6: $(a, b, c) \rightarrow (c, b, a)$	$(ac)(b)$	$t_1 t_2$

The cycle index of this permutation group is then

$$C_3 = (1/6) (t_1^3 + 3t_1 t_2 + 2t_3)$$



### Cycle Index of the Symmetrical Group

Symmetrical group of  $n$  objects is the set of all possible permutations of  $n$  objects. The order of the symmetrical group of  $n$  objects is  $n!$ . The cycle index of the symmetrical group,  $C_n$ , is the summation of the types of  $n!$  permutations, divided by  $n!$ . The cycle index  $C_n$  is also equal to the coefficient of  $Z^n$  in the power-series expansion of  $e^q$ , where

$$q = Zt_1 + (1/2) Z^2 t_2 + (1/3) Z^3 t_3 + \dots \quad (2-10)$$

$$\text{and } e^q = 1 + q + (1/2!) q^2 + (1/3!) q^3 + \dots \quad (2-11)$$

Example 2-3 Find the cycle index of the symmetrical group of 3 objects by Eqs. (2-10), (2-11).

Solution: Let us substitute  $q$  from Eq. (2-10) into Eq. (2-11) to get

$$e^q = Z^3 (1/3 t_3 + 1/2! t_1 t_2 + 1/3! t_1^3) + \dots$$

Therefore,  $C_3$  is equal to the coefficient of  $Z^3$ , that is

$$C_3 = (1/6) (t_1^3 + 3t_1 t_2 + 2t_3)$$

The expression for  $C_3$  derived here does conform with that in

Example 2-2.

Table I shows the first six cycle indices of the symmetrical groups for a maximum of 6 objects [57].

TABLE I  
THE FIRST SIX CYCLE INDICES OF  
SYMMETRICAL GROUP,  $C_n$

$$C_1 = (1/1!) (t_1)$$

$$C_2 = (1/2!) (t_1^2 + t_2)$$

$$C_3 = (1/3!) (t_1^3 + 3t_1t_2 + 2t_3)$$

$$C_4 = (1/4!) (t_1^4 + 6t_1^2t_2 + 3t_2^2 + 8t_1t_3 + 6t_4)$$

$$C_5 = (1/5!) (t_1^5 + 10t_1^3t_2 + 15t_1t_2^2 + 20t_1^2t_3 + 20t_2t_3 \\ + 30t_1t_4 + 24t_5)$$

$$C_6 = (1/6!) (t_1^6 + 15t_1^4t_2 + 45t_1^2t_2^2 + 40t_1^3t_3 + 15t_2^3 \\ + 120t_1t_2t_3 + 90t_1^2t_4 + 40t_3^2 + 90t_2t_4 \\ + 144t_1t_5 + 120t_6)$$

#### Cycle Index of the Dihedral Group

The dihedral group is a group of rigid-body motions which are performed by means of rotations and reflections of a plane regular polygon. The dihedral group of a plane regular polygon of  $n$  sides is of order  $2n$ . The order  $2n$  is also equal to the total number of covering operations on the polygon. The number of rotations is equal to  $n$  (including identity) and the remainder  $n$  is the number of

reflections.

Example 2-4 Find the cycle index of the dihedral group of the pentagon shown in Fig. 5.

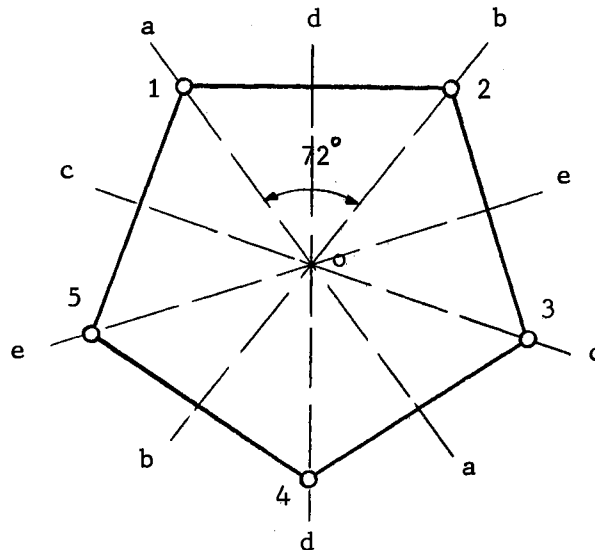


Figure 5. Pentagon and Its Axes of Symmetry

Solution: A table is presented in the following page showing the different covering operations, permutations of vertices and their corresponding types.

Covering Operation	Vertex Permutation	Type
Identity	(1)(2)(3)(4)(5)	$t_1^5$
72° rotation about o	(12345)	$t_5$
144° rotation about o	(13524)	$t_5$
216° rotation about o	(14253)	$t_5$
288° rotation about o	(15432)	$t_5$
Reflection about aa	(1)(25)(34)	$t_1 t_2^2$
Reflection about bb	(2)(13)(45)	$t_1 t_2^2$
Reflection about cc	(3)(15)(24)	$t_1 t_2^2$
Reflection about dd	(4)(12)(35)	$t_1 t_2^2$
Reflection about ee	(5)(14)(23)	$t_1 t_2^2$

Therefore, the cycle index  $D_5$  of the dihedral group of the pentagon is  $(1/10) (t_1^5 + 5t_1 t_2^2 + 4t_5)$ .

The cycle index  $D_n$  for a plane regular polygon of  $n$  sides, for  $n = 3, 4, \dots, 7$  is shown in Table II.

TABLE II

## THE CYCLE INDICES OF DIHEDRAL GROUP

$$D_n (t_1, \dots, t_n), n = 3, 4, \dots, 7$$

$$D_3 = (1/6) (t_1^3 + 2t_3 + 3t_1 t_2)$$

$$D_4 = (1/8) (t_1^4 + 2t_1^2 t_2 + 3t_2^2 + 2t_4)$$

$$D_5 = (1/10) (t_1^5 + 5t_1 t_2^2 + 4t_5)$$

$$D_6 = (1/12) (t_1^6 + 3t_1^2 t_2^2 + 4t_2^3 + 2t_3^2 + 2t_6)$$

$$D_7 = (1/14) (t_1^7 + 6t_7 + 7t_1 t_2^3)$$

## Cycle Index of the Full Pair Group

The full pair group is a group of permutations of all the point pairs  $\frac{1}{2} v(v-1)$  of  $v$  vertices. This group is in one-to-one correspondence with the symmetrical group [54,88]; that is, for a given type in the cycle index of a symmetrical group,  $C_n$ , there always exists a corresponding type in the cycle index of the full pair group,  $R_n$ . The full group plays an important role in the enumeration of graphs having  $v$  vertices and  $e$  edges. Any graph with  $v$  vertices and  $e$  edges can be represented by multicolored full pair group. For example, a linear graph with 4 vertices and 5 edges can be represented by bi-colored full pair group in which one color is for the 5 existing edges, the other color for the non-existing edges. The total number of point pairs in a complete graph is  $\frac{1}{2} v(v-1) = \frac{1}{2} 4(3) = 6$ , this number is

equal to the sum of the existing and non-existing edges in that graph.

An example of the full pair group having 4 vertices is used to illustrate the procedures to obtain the cycle index of the full pair group  $R_n$  from that of symmetrical group  $C_n$  and is shown in Table III.

It should be noted that for a given type in  $C_4$ , there always exists a corresponding type in  $R_4$  regardless of the particular permutation chosen for that type. For example, for the type  $t_1 t_2$  in  $C_4$ , either permutation (1)(2)(34) or (1)(3)(24) will result in the same corresponding type  $t_1 t_2^2$  in  $R_4$ . From Table III,  $t_1^4$ ,  $t_1^2 t_2^2$ , ... are substituted by  $t_1^6$ ,  $t_1^2 t_2^2$ , ... in the cycle index  $C_4$  and it becomes the cycle index of full pair group  $R_4$ :

$$\begin{aligned} R_4 &= (1/4!) (t_1^6 + 6t_1^2 t_2^2 + 8t_3^2 + 3t_1^2 t_2^2 + 6t_2 t_4) \\ &= (1/4!) (t_1^6 + 9t_1^2 t_2^2 + 8t_3^2 + 6t_2 t_4) \end{aligned} \quad (2-12)$$

#### Cycle Index of Polyhedral Group

The polyhedral group is the group of three-dimensional motion of a rigid body. The motion consists of rotations of the rigid body about the rotational axes in space. The cycle index of polyhedral group is the summation of the types of permutations about the rotational axes in space, divided by the number of permutations.

The cycle index of a pyramid with respect to the faces, and that of a cube with respect to the vertices are obtained by first constructing the rotational axes of the rigid body and then finding the types of permutations. The procedures for finding the cycle indices of these two cases are described in the following two examples:

TABLE III  
 PROCEDURES FOR OBTAINING THE CYCLE INDEX  
 OF FULL PAIR GROUP,  $R_4$

Unpermuted edge  Point pair $a_i = (v_m, v_n)$	Permutation types of $C_4$ operating on $a_i$				
	$t_1^4$ (1)(2)(3)(4)	$t_1^2 t_2$ (1)(2)(34)	$t_1 t_3$ (1)(234)	$t_2^2$ (12)(34)	$t_4$ (1234)
$a_1 = (1,2)$	$(1,2) = a_1$	$(1,2) = a_1$	$(1,3) = a_2$	$(2,1) = a_1$	$(2,3) = a_4$
$a_2 = (1,3)$	$(1,3) = a_2$	$(1,4) = a_3$	$(1,4) = a_3$	$(2,4) = a_5$	$(2,4) = a_5$
$a_3 = (1,4)$	$(1,4) = a_3$	$(1,3) = a_2$	$(1,2) = a_1$	$(2,3) = a_4$	$(2,1) = a_1$
$a_4 = (2,3)$	$(2,3) = a_4$	$(2,4) = a_5$	$(3,4) = a_6$	$(1,4) = a_3$	$(3,4) = a_6$
$a_5 = (2,4)$	$(2,4) = a_5$	$(2,3) = a_4$	$(3,2) = a_4$	$(1,3) = a_2$	$(3,1) = a_2$
$a_6 = (3,4)$	$(3,4) = a_6$	$(3,4) = a_6$	$(4,2) = a_5$	$(4,3) = a_6$	$(4,1) = a_3$
Cyclic representation of permutation	$(a_1)(a_2)(a_3)$ $(a_4)(a_5)(a_6)$	$(a_1)(a_6)$ $(a_2 a_3)(a_4 a_5)$	$(a_1 a_2 a_3)$ $(a_4 a_6 a_5)$	$(a_1)(a_6)$ $(a_2 a_5)(a_3 a_4)$	$(a_2 a_5)$ $(a_1 a_4 a_6 a_3)$
Corresponding Types in cycle index of full pair group ( $R_4$ )	$t_1^6$	$t_1^2 t_2^2$	$t_3^2$	$t_1^2 t_2^2$	$t_2 t_4$

Example 2-5 Find the cycle index of the pyramid with respect to the four faces shown in Fig. 6.

Solution: The pyramid has four faces 1,2,3 and 4 with face 4 as base. The rotational axis XX is passing through point o and perpendicular to the base. The types of permutations are obtained as follows:

Covering Operation	Face Permutation	Type
Identity	(1)(2)(3)(4)	$t_1^4$
$120^\circ$ rotation about XX	(123)(4)	$t_1 t_3$
$240^\circ$ rotation about XX	(132)(4)	$t_1 t_3$

Therefore, the cycle index of the pyramid with respect to the faces is

$$P_4 = (1/3) (t_1^4 + 2t_1 t_3) \quad (2-13)$$

Example 2-6 Find the cycle index of a cube with respect to the 8 vertices shown in Fig. 7.

Solution: A table prepared to show the operations of rotations about different axes<sup>1</sup> is presented on page 33.

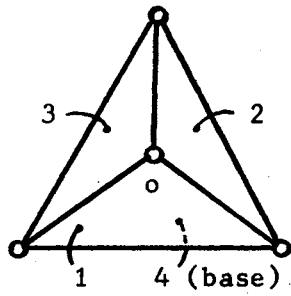
Therefore, the cycle index of a cube with respect to 8 vertices is

$$P_8 = (1/24) (t_1^8 + 9t_2^4 + 6t_4^2 + 8t_1^2 t_3^2) \quad (2-14)$$

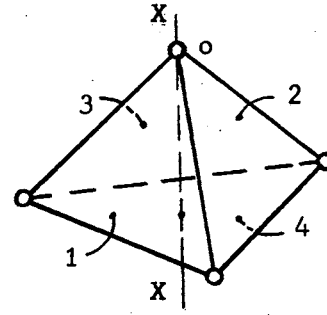

---

<sup>1</sup>P<sub>45-27</sub> is the axis crossing edges 45,27. R<sub>25</sub> is the axis passing through vertices 2 and 5.



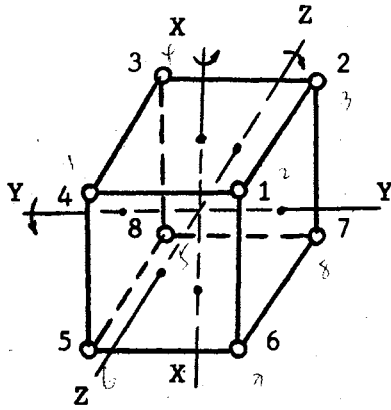


(a)

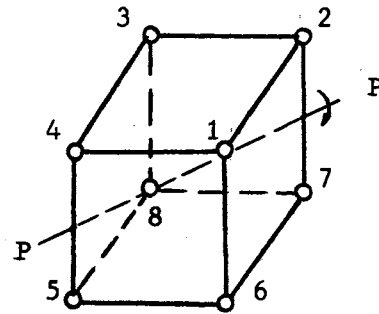


(b)

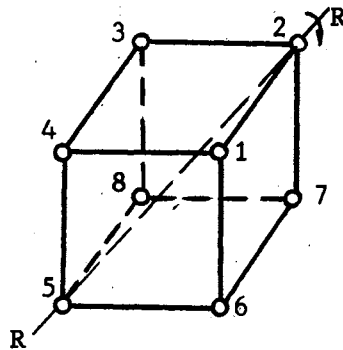
Figure 6. A Pyramid and Its Axis of Rotation



(a)



(b)



(c)

Figure 7. A Cube and Its Axes of Rotation

Rotating Operation	Vertex Permutation	Type
Identity	(1)(2)(3)(4)(5)(6)(7)(8)	$t_1^8$
90° about XX	(1234)(5678)	$t_4^2$
180° about XX	(13)(24)(57)(68)	$t_2^4$
270° about XX	(1432)(5876)	$t_4^2$
90° about YY	(1672)(4583)	$t_4^2$
180° about YY	(17)(26)(48)(35)	$t_2^4$
270° about YY	(1276)(4385)	$t_4^2$
90° about ZZ	(2783)(1654)	$t_4^2$
180° about ZZ	(28)(37)(15)(46)	$t_2^4$
270° about ZZ	(2387)(1456)	$t_4^2$
180° about $P_{45-27}$	(45)(27)(18)(36)	$t_2^4$
180° about $P_{16-38}$	(16)(38)(25)(47)	$t_2^4$
180° about $P_{23-56}$	(23)(56)(18)(47)	$t_2^4$
180° about $P_{14-78}$	(14)(78)(25)(36)	$t_2^4$
180° about $P_{12-58}$	(12)(58)(36)(47)	$t_2^4$
180° about $P_{67-43}$	(67)(43)(18)(25)	$t_2^4$
120° about $R_{25}$	(2)(5)(137)(486)	$t_1^2 t_3^2$
120° about $R_{18}$	(1)(8)(264)(375)	$t_1^2 t_3^2$
120° about $R_{47}$	(4)(7)(153)(268)	$t_1^2 t_3^2$
120° about $R_{36}$	(3)(6)(248)(157)	$t_1^2 t_3^2$
<del>120°</del> 240° about $R_{25}$	(2)(5)(173)(468)	$t_1^2 t_3^2$
240° about $R_{18}$	(1)(8)(246)(357)	$t_1^2 t_3^2$
240° about $R_{47}$	(4)(7)(135)(286)	$t_1^2 t_3^2$
240° about $R_{36}$	(3)(6)(284)(175)	$t_1^2 t_3^2$

### Polya's Theory and Its Application

Polya's theory: The total of all unequivalent colored patterns is obtained by substituting the weight function  $\sum_{j=1}^k W_j^i$  for  $t_i$  in the cycle index of a permutation group, where  $k$  is the number of color elements and  $i$  is the length of cycle  $t$ . For a two-color pattern,  $k = 2$  and  $t_i = x^i + y^i$ ; for a three color pattern,  $k = 3$  and  $t_i = x^i + y^i + z^i$  and so forth [51,52,53,54].

The problem of the enumeration of linear graphs is equivalent to finding the number of unequivalent ways of coloring the  $\frac{1}{2} v(v-1)$  edges of the complete graph of  $v$  vertices with two colors (say red for one edge, black for no edge). The cycle index of the full pair group  $R_v$  is to be applied to show the application of the theory and an example is shown below.

Example 2-7 Enumerate the linear graphs having 4 vertices.

Solution: The complete linear graph having 4 vertices has  $\frac{1}{2} v(v-1) = \frac{1}{2} 4(4-1) = 6$  edges. From Eq. (2-12), the cycle index of full pair group of 4 vertices is

$$R_4 = (1/4!) (t_1^6 + 9t_1^2 t_2^2 + 8t_3^2 + 6t_2 t_4)$$

substituting  $t_i = x^i + y^i$ ,  $i = 1, 2, 3, 4$

into  $R_4$ , it becomes

$$R_4(x, y) = x^6 + x^5 y + 2x^4 y^2 + 3x^3 y^3 + 2x^2 y^4 + xy^5 + y^6 \quad (2-15)$$

The coefficients of each term in Eq. (2-15) represent the number of unequivalent patterns having the same weight. For the total number

of unequivalent patterns, the sum of all coefficients is computed as follows.

$$R_4(x,y) = R_4(1,1) = 11$$

All the eleven unequivalent patterns are shown in Table IV.

If double-edges are permitted between any two vertices, then the enumeration becomes a 3-color problem, that is, between any two vertices of a graph, there exist three types of edges: no edge, one edge and double-edge. The enumeration of 3-colored graphs with  $v$  vertices is obtained by substituting  $t_i = x^i + y^i + z^i$  into the cycle index of the full pair group  $R_v$ .

Example 2-8 Enumerate the numbers of non-linear graphs having 4 vertices with the following weights:


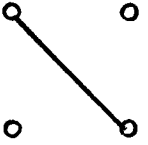
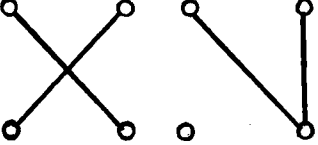
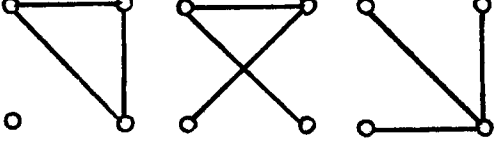
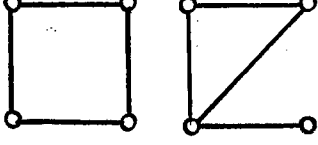
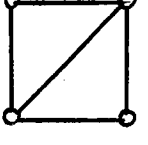
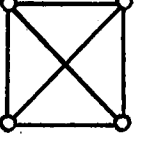
- |     |            |       |                |
|-----|------------|-------|----------------|
| (1) | $y^5 z$    |       | x: no edge     |
| (2) | $xy^3 z^2$ | where | y: one edge    |
| (3) | $x^2 yz^3$ |       | z: double-edge |

Solution: Let  $t_i = x^i + y^i + z^i$ ,  $i = 1, 2, 3, 4$

and substitute  $t_i$  into Eq. (2-12) which is the cycle index of full pair group of 4 vertices, Eq. (2-12) becomes

$$\begin{aligned}
 R_4(x,y,z) = & (x^6 + x^5 y + 2x^4 y^2 + 3x^3 y^3 + 2x^2 y^4 + xy^5 + y^6) + \\
 & (x^5 + 2x^4 y + 4x^3 y^2 + 4x^2 y^3 + 2xy^4 + y^5)z + \\
 & 2(x^4 + 2x^3 y + 3x^2 y^2 + 2xy^3 + y^4)z^2 + \\
 & (3x^3 + 4x^2 y + 4xy^2 + 3y^3)z^3 + \\
 & 2(x^2 + xy + y^2)z^4 + (x + y)z^5 + z^6
 \end{aligned} \tag{2-16}$$

TABLE IV  
ALL THE LINEAR GRAPHS HAVING 4 VERTICES

Graph		Patterns	Weight	Coefficient
Vertices	Edges			
4	0		$x^6$	1
	1		$x^5 y$	1
	2		$x^4 y^2$	2
	3		$x^3 y^3$	3
	4		$x^2 y^4$	2
	5		$xy^5$	1
	6		$y^6$	1
	Total Number of Linear Graphs			

There are seven terms in Eq. (2-16), the first term is same as Eq. (2-15) which is the equation for the enumeration of linear graphs, the remainder of the terms represent the number of non-linear graphs having different weights with the number of double-edges ranging from one to six.

Table V is prepared to show the number of non-linear graphs having 4 vertices with weights  $y^5z$ ,  $xy^3z^2$  and  $x^2yz^3$ .

The applications of the cycle index of the polyhedral group are shown by the following two examples:

Example 2-9 Find the distinct ways of painting the four faces of the pyramid shown in Example 2-5 with two colors.

Solution: The cycle index of the pyramid with respect to the four faces has been found in Example 2-5 as

$$P_4 = (1/3) (t_1^4 + 2t_1t_3)$$

Let  $t_i = x^i + y^i, \quad i = 1,3$

substituting  $t_i$  into  $P_4$ , it becomes

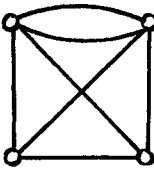
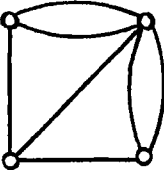
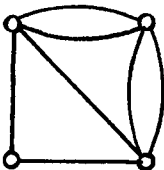
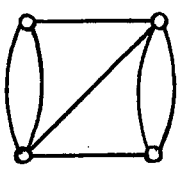
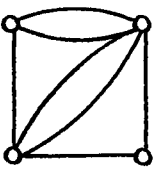
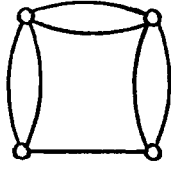
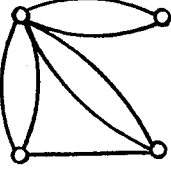
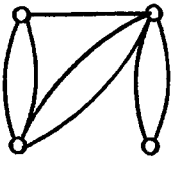
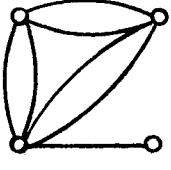
$$P_4(x,y) = x^4 + 2x^3y + 2x^2y^2 + 2xy^3 + y^4$$

Let the two colors be x (red) and y (green), then the number of ways of painting the four faces of the pyramid with three reds and one green is equal to the coefficient of  $x^3y$ , that is 2. The total number of ways of painting the four faces of the pyramid with two colors is equal to

$$P_4(1,1) = 1 + 2 + 2 + 2 + 1 = 8$$

TABLE V

NON-LINEAR GRAPHS HAVING 4 VERTICES WITH  
WEIGHTS  $y^5 z$ ,  $xy^3 z^2$  and  $x^2 yz^3$

Vertices	Weights x: no edge y: one edge z: double- edge	Coeffi- cient	Patterns
	$y^5 z$	1	1. 
4	$xy^3 z^2$	4	2.  3.  4.  5. 
	$x^2 yz^3$	4	6.  7.  8.  9. 

Example 2-10 Find the distinct ways of painting the eight vertices of a cube with two colors.

Solution: The cycle index of a cube with respect to the 8 vertices has been obtained in Example 2-6 as

$$P_8 = (1/24) (t_1^8 + 9t_2^4 + 6t_4^2 + 8t_1^2 t_3^2)$$

substituting  $t_i = x^i + y^i$ ,  $i = 1, 2, 3, 4$

into  $P_8$ , it becomes

$$\begin{aligned} P_8(x, y) = & x^8 + x^7 y + 3x^6 y^2 + 3x^5 y^3 + 7x^4 y^4 \\ & + 3x^3 y^5 + 3x^2 y^6 + xy^7 + y^8 \end{aligned}$$

The total number of distinct ways of painting the eight vertices of a cube with two colors is equal to

$$P_8(1, 1) = 23$$



## CHAPTER III

### SYNTHESIS OF LINEAR AND NON-LINEAR COLORED GRAPHS

The specifications of linear and non-linear colored graphs and the listing of specifications with certain number of vertices and edges are described. A general scheme is developed to synthesize the vertex-vertex incidence matrices of colored graphs from a given specification. A general computer program which takes into account any number of vertices and any number of different colored edges has been developed and shown in Program B, Appendix B. In the last section, a method of cut-set matrix with modulo-2 operation is applied to enumerate exclusively the linear two-colored graphs with trees.

#### Specifications of Colored Graphs

The specification of a colored graph is defined as the set of degrees of vertices of each subgraph  $[s_1^j s_2^j \dots s_m^j]$ , or  $[s_i^j]$ , where  $s_i^j$  is the degree of vertex  $i$  of subgraph  $j$  and  $m$  is the number of vertices of the colored graph. The colored graph having  $n$  types of colored edges is called  $n$ -colored graph.  $n$ -colored graph has  $n$  subgraphs. For the case of 1-colored graph, the colored graph itself is the subgraph. For the case of two-colored graph, the specification is formed as follows.

$$\begin{pmatrix} s_1^1 & s_2^1 & \dots & s_m^1 \\ s_1^2 & s_2^2 & \dots & s_m^2 \end{pmatrix}$$

The first and second rows of the specification represent the degrees of vertices of first and second subgraphs of the two-colored graph respectively.

In general, two graphs having the same specification are not necessary to be isomorphic. This is because the specification of a graph only shows the listing of degrees of vertices of the graph, the listing itself does not take into account the connections between vertices. Fig. 8 shows two one-colored graphs having the same specification [322322] but are not isomorphic. Although the two two-colored graphs shown in Fig. 9 have the same specification  $\begin{bmatrix} 12221 \\ 21111 \end{bmatrix}$ , these graphs are not isomorphic.

Given the number of vertices and edges of a colored graph, its specification has to satisfy the following equation:

$$\sum_{i=1}^v s_i^j = 2 \times e^j \quad (3-1)$$

where  $s_i^j$ : degree of vertex  $i$  of subgraph  $j$ .

$v$ : number of vertices of colored graph.

$e^j$ : number of edges of subgraph  $j$ .

For the two-colored graphs shown in Fig. 9, we have  $e^1$  (fine edges) = 4 and  $e^2$  (heavy edges) = 3, therefore

$$\sum_{i=1}^5 s_i^1 = 1 + 2 + 2 + 2 + 1 = 8 = 2 \times e^1 = 2 \times 4$$

and  $\sum_{i=1}^5 s_i^2 = 2 + 1 + 1 + 1 + 1 = 6 = 2 \times e^2 = 2 \times 3$

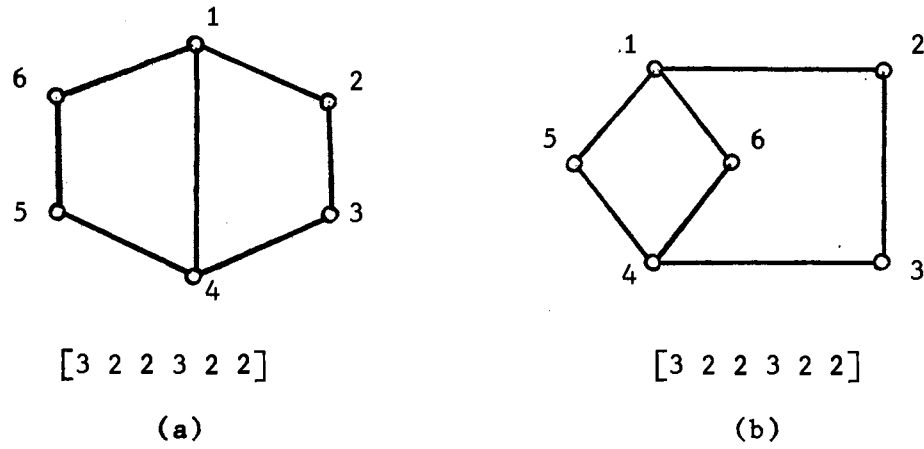


Figure 8. Two One-Colored Graphs Having the Same Specification But Are Not Isomorphic

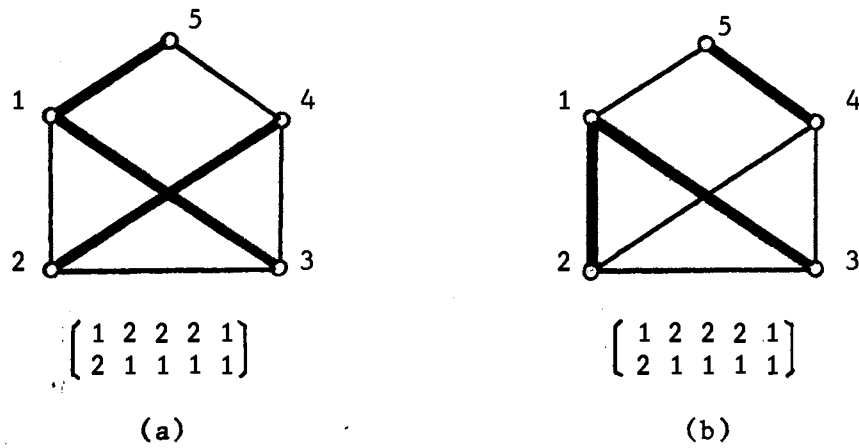


Figure 9. Two Two-Colored Graphs Having the Same Specification But Are Not Isomorphic

It should be noted that Eq. (3-1) is also valid for the non-linear colored-graphs. Fig. 10 shows a non-linear two-colored graphs having 4 vertices and its specification.

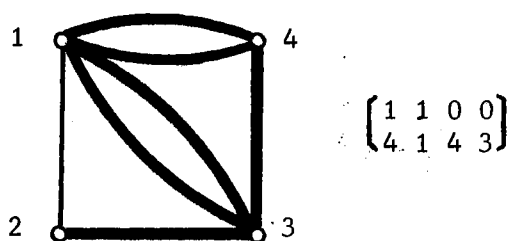


Figure 10. A Non-Linear Two-Colored Graph

The listing of the specifications of a colored graph is the set of solutions of  $S_i^j$  of Eq. (3-1). Therefore, given the number of vertices  $v$  and edges  $e^j$  of subgraph  $j$ , the list of specifications can be obtained. A computer program has been developed to generate the listing of specifications and is shown in Program A, Appendix B. The detail usage of this program is also described in Appendix B.

In the next section, the procedures to synthesize the vertex-vertex incidence matrices of colored graphs from a given specification will be presented.

### Synthesis of Vertex-Vertex Incidence Matrices

A vertex-vertex incidence matrix (v-v incidence matrix) is a square and symmetrical matrix with all zeros in diagonal elements. The sum of the elements in row  $i$  (or column  $i$ ) is the degree of vertex,  $S_i$ . The element  $a_{ij}$  of the matrix is the number of edges between vertex  $i$  and vertex  $j$ . For the general case, there are different types (or colors) of edges in a graph. For example, a graph with fine and heavy edges has two types of edges. Therefore, in order to represent  $a_{ij}$  by a digit number in terms of different types of edges, a method of representation of  $a_{ij}$  is developed as follows.

$$a_{ij} = xy \text{ (digit number)}$$

The number of places of the digit number is the number of types of edges in a graph. Then each place of the digit number represents the number of certain type of edge. In the case of having two types of edges in a graph, say fine and heavy edges, the ones place is for the number of fine edges and tens place is for the number of heavy edges. It should be noted that the sum of the numbers in different places of the digit number of  $a_{ij}$  is the total number of edges between vertex  $i$  and vertex  $j$ .

Example 3-2 Form the v-v incidence matrix for the graph shown in Fig. 11.

Solution: The v-v incidence matrix is formed as follows.

$$[M_{vv}] = \begin{bmatrix} 0 & 1 & 10 & 10 \\ 1 & 0 & 1 & 0 \\ 10 & 1 & 0 & 1 \\ 10 & 0 & 1 & 0 \end{bmatrix}$$

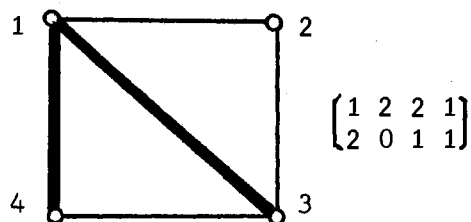


Figure 11. A Linear Two-Colored Graph

Since  $v$ - $v$  incidence matrix is symmetrical, it is sufficient to consider only the upper triangle of the matrix in order to synthesize the  $v$ - $v$  incidence matrix from a given specification. A general form of  $v$ - $v$  incidence matrix is shown below with all diagonal elements equal to zeros and  $a_{ij} = a_{ji}$ . The sum of the elements in row  $i$  (or column  $i$ ) is the degree of vertex  $i$ ,  $S_i$ .

$$[M_{vv}] = \begin{pmatrix} 0 & a_{12} & a_{13} & \cdots & a_{1\ m-1} & a_{1m} \\ a_{21} & 0 & a_{23} & \cdots & a_{2\ m-1} & a_{2m} \\ a_{31} & a_{32} & 0 & \cdots & a_{3\ m-1} & a_{3m} \\ \vdots & \vdots & \vdots & \vdots & \vdots & \vdots \\ \vdots & \vdots & \vdots & \vdots & \vdots & \vdots \\ a_{m-1\ 1} & a_{m-1\ 2} & a_{m-1\ 3} & \cdots & 0 & a_{m-1\ m} \\ a_{m1} & a_{m2} & a_{m3} & \cdots & a_{m\ m-1} & 0 \end{pmatrix}$$

For a  $n$ -colored graph, there are  $n$  subgraphs. If we consider the Eq. (3-2) as the  $v$ - $v$  incidence matrix of subgraph  $j$ , then

$$s_{11}^j = a_{12} + a_{13} + \dots + a_{1\ m-1} + a_{1m} \quad (3-3)$$

$$b_{22} = s_2^j - a_{12} = a_{23} + a_{24} + \dots + a_{2\ m-1} + a_{2m} \quad (3-4)$$

$$b_{33} = s_3^j - a_{13} - a_{23} = a_{34} + a_{35} + \dots + a_{3\ m-1} + a_{3m} \quad (3-5)$$

.....

.....

Eqs. (3-3), (3-4), (3-5) and so forth show the relationship between the elements of a  $v$ - $v$  incidence matrix and the degrees of vertices.

The synthesis of  $v$ - $v$  incidence matrices of  $n$ -colored graphs can be accomplished by considering each subgraph individually. Given a  $n$ -colored graph specification, the  $v$ - $v$  incidence matrices for each subgraph specification are to be synthesized first, then all the possible combinations (or superpositions) of the  $v$ - $v$  incidence matrices of  $n$  subgraphs become the final  $v$ - $v$  incidence matrices synthesized for the given  $n$ -colored graph specification.

The procedures to synthesize the  $v$ - $v$  incidence matrices of subgraph  $j$  are presented as follows.

Procedures:

1. Given the specification of subgraph  $j$ ,  $[s_1^j, s_2^j, \dots, s_m^j]$ .
2. According to Eq. (3-3), find the all possible distributions (submatrices) of  $s_1^j$  among columns 2,3, ...  $m$ . For 1-colored graph, the number of distributions of  $s_1^j$  should not include the sets of repetitions. This is to exclude the introduction of isomorphic graphs. For  $n$ -colored graph, where  $n > 1$ , all

possible distributions should be included. This is to introduce the non-isomorphic graphs due to the superpositions of all subgraphs. (See Example 3-3 and 3-4).

3. For each possible distribution, subtract  $a_{12}, a_{13}, \dots, a_{1m}$  from  $S_2^j, S_3^j, \dots, S_m^j$  to get  $b_{22}, b_{23}, \dots, b_{2m}$ .
4. According to Eq. (3-4), find the all possible distributions of  $b_{22}$  among columns 3,4, ..., m.
5. For each possible distribution, subtract  $a_{23}, a_{24}, \dots, a_{2m}$  from  $b_{23}, b_{24}, \dots, b_{2m}$  to get  $b_{33}, b_{34}, \dots, b_{3m}$ .
6. The procedures of distribution are continued until the number to be distributed is for the last column.
7. If the distribution becomes impossible, then the corresponding incidence matrix does not exist.
8. Form the v-v incidence matrix of subgraph j by combining the different submatrices, completing lower triangle of matrix and filling out the diagonal elements with zeros.

The procedures described above end up with a problem of collecting tree branches. The technique to collect the tree branches has been developed and shown in the main program of computer program B (Appendix B).

Example 3-3: Synthesize all possible v-v incidence matrices of linear 1-colored graphs with the specification [332222].

Solution: According to the procedures described above, we obtain the following submatrices.

$$(I) \quad A1: \begin{array}{cccccc} 3 & 3 & 2 & 2 & 2 & 2 \\ 3 & x & 1 & 0 & 0 & 1 & 1 \end{array}$$

$$(II) \quad A2: \begin{array}{cccccc} 3 & 3 & 2 & 2 & 2 & 2 \\ 3 & x & 0 & 0 & 1 & 1 & 1 \end{array}$$





$$\begin{array}{c} \text{A231: } \frac{1 \ 0 \ 1 \ 0}{1 \ \underline{x \ 0 \ 1 \ 0}} \\ \text{(completed)} \end{array}$$

$$\begin{array}{c} \text{A241: } \frac{1 \ 0 \ 0 \ 1}{1 \ \underline{x \ 0 \ 0 \ 1}} \\ \text{(completed)} \end{array}$$

Let the v-v incidence matrices of the different combinations of the submatrices be:

$$[M_{vv}^1] = A1 + A11 + A111 + A1111$$

$$[M_{vv}^2] = A1 + A11 + A112 + A1121$$

$$[M_{vv}^3] = A1 + A11 + A113 + A1131 + A11311$$

$$[M_{vv}^4] = A1 + A12 + A121$$

$$[M_{vv}^5] = A1 + A14 + A141 + A1411$$

$$[M_{vv}^6] = A1 + A15 + A151 + A1511$$

$$[M_{vv}^7] = A1 + A16 + A161$$

$$[M_{vv}^8] = A2 + A21 + A211$$

$$[M_{vv}^9] = A2 + A23 + A231$$

$$[M_{vv}^{10}] = A2 + A24 + A241$$

There are ten v-v incidence matrices obtained from the given specification [332222]. Among them, only four v-v incidence matrices are non-isomorphic to each other, they are

$$(1) \quad [M_{vv}^1] = [M_{vv}^2]$$

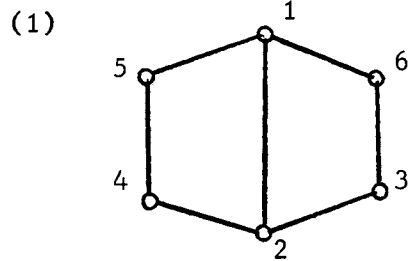
$$(2) \quad [M_{vv}^3]$$

$$(3) \quad [M_{vv}^4] = [M_{vv}^5] = [M_{vv}^6] = [M_{vv}^7]$$

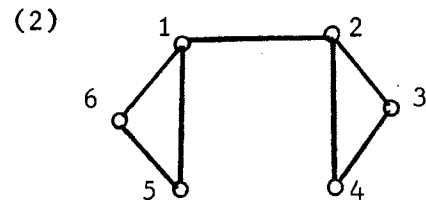
$$(4) \quad [M_{vv}^8] = [M_{vv}^9] = [M_{vv}^{10}]$$

Fig. 12 shows the four v-v incidence matrices and their corresponding graphs.

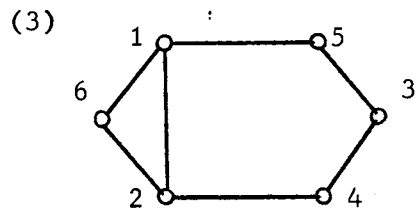
$$[M_{VV}^1] = \begin{bmatrix} 0 & 1 & 0 & 0 & 1 & 1 \\ 1 & 0 & 1 & 1 & 0 & 0 \\ 0 & 1 & 0 & 0 & 0 & 1 \\ 0 & 1 & 0 & 0 & 1 & 0 \\ 1 & 0 & 0 & 1 & 0 & 0 \\ 1 & 0 & 1 & 0 & 0 & 0 \end{bmatrix}$$



$$[M_{VV}^3] = \begin{bmatrix} 0 & 1 & 0 & 0 & 1 & 1 \\ 1 & 0 & 1 & 1 & 0 & 0 \\ 0 & 1 & 0 & 1 & 0 & 0 \\ 0 & 1 & 1 & 0 & 0 & 0 \\ 1 & 0 & 0 & 0 & 0 & 1 \\ 1 & 0 & 0 & 0 & 1 & 0 \end{bmatrix}$$



$$[M_{VV}^4] = \begin{bmatrix} 0 & 1 & 0 & 0 & 1 & 1 \\ 1 & 0 & 0 & 1 & 0 & 1 \\ 0 & 0 & 0 & 1 & 1 & 0 \\ 0 & 1 & 1 & 0 & 0 & 0 \\ 1 & 0 & 1 & 0 & 0 & 0 \\ 1 & 1 & 0 & 0 & 0 & 0 \end{bmatrix}$$



$$[M_{VV}^8] = \begin{bmatrix} 0 & 0 & 0 & 1 & 1 & 1 \\ 0 & 0 & 1 & 0 & 1 & 1 \\ 0 & 1 & 0 & 1 & 0 & 0 \\ 1 & 0 & 1 & 0 & 0 & 0 \\ 1 & 1 & 0 & 0 & 0 & 0 \\ 1 & 1 & 0 & 0 & 0 & 0 \end{bmatrix}$$

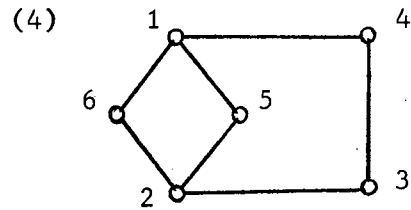


Figure 12. Four V-V Incidence Matrices and  
Their Corresponding Graphs  
Obtained from [332222]

Example 3-4 Synthesize all possible v-v incidence matrices of linear and non-linear 2-colored graphs for the specification  $\begin{bmatrix} 1212 \\ 2110 \end{bmatrix}$ .

Solution: According to the procedures, the subgraphs for  $[1212]$  will be synthesized first.

A. Subgraphs for  $[1212]$ :

$$(I). A1: \begin{array}{cccc} 1 & 2 & 1 & 2 \\ \hline 1 & x & 1 & 0 & 0 \end{array} \quad (II). A2: \begin{array}{cccc} 1 & 2 & 1 & 2 \\ \hline 1 & x & 0 & 1 & 0 \end{array} \quad (III). A3: \begin{array}{cccc} 1 & 2 & 1 & 2 \\ \hline 1 & x & 0 & 0 & 1 \end{array}$$

$$(I): A11: \begin{array}{ccc} 1 & 1 & 2 \\ \hline 1 & x & 1 & 0 \end{array} \quad A12: \begin{array}{ccc} 1 & 1 & 2 \\ \hline 1 & x & 0 & 1 \end{array} \quad A111: \begin{array}{cc} 0 & 2 \\ \hline 0 & x \end{array}$$

(rejected)

$$A121: \begin{array}{cc} 1 & 1 \\ \hline 1 & x & 1 \end{array}$$

(completed)

$$(II): A21: \begin{array}{ccc} 2 & 0 & 2 \\ \hline 2 & x & 0 & 2 \end{array} \quad (III): A31: \begin{array}{ccc} 2 & 1 & 1 \\ \hline 2 & x & 1 & 1 \end{array}$$

(completed) (completed)

Therefore,  $[M_{vv}^1]_1 = A1 + A12 + A121$

$$[M_{vv}^2]_1 = A2 + A21$$

$$[M_{vv}^3]_1 = A3 + A31$$

The three v-v incidence matrices and their subgraphs for  $[1212]$  are shown in Fig. 13.

The subgraphs for  $[2110]$  are then to be synthesized.

B. Subgraphs for  $[2110]$ :

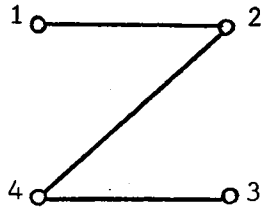
$$(I). A1: \begin{array}{cccc} 2 & 1 & 1 & 0 \\ \hline 2 & x & 1 & 1 & 0 \end{array} \quad A11: \begin{array}{ccc} 0 & 0 & 0 \\ \hline 0 & x & 0 & 0 \end{array}$$

(completed)

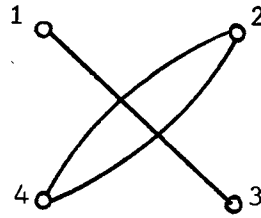
Therefore,  $[M_{vv}^1]_2 = A1 + A11$

The v-v incidence matrix and its subgraph are shown in Fig. 13.

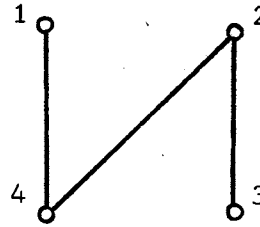
$$[M_{vv}^1]_1 = \begin{pmatrix} 0 & 1 & 0 & 0 \\ 1 & 0 & 0 & 1 \\ 0 & 0 & 0 & 1 \\ 0 & 1 & 1 & 0 \end{pmatrix}$$



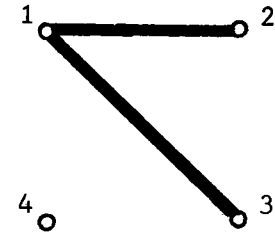
$$[M_{vv}^2]_1 = \begin{pmatrix} 0 & 0 & 1 & 0 \\ 0 & 0 & 0 & 2 \\ 1 & 0 & 0 & 0 \\ 0 & 2 & 0 & 0 \end{pmatrix}$$



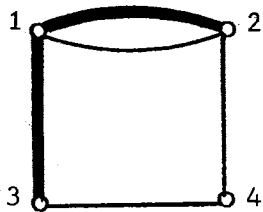
$$[M_{vv}^3]_1 = \begin{pmatrix} 0 & 0 & 0 & 1 \\ 0 & 0 & 1 & 1 \\ 0 & 1 & 0 & 0 \\ 1 & 1 & 0 & 0 \end{pmatrix}$$



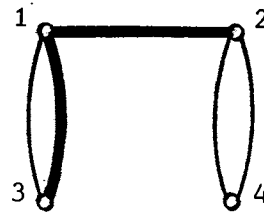
$$[M_{vv}^1]_2 = \begin{pmatrix} 0 & 1 & 1 & 0 \\ 1 & 0 & 0 & 0 \\ 1 & 0 & 0 & 0 \\ 0 & 0 & 0 & 0 \end{pmatrix}$$



$$[M_{vv}^1] = \begin{pmatrix} 0 & 11 & 10 & 0 \\ 11 & 0 & 0 & 1 \\ 10 & 0 & 0 & 1 \\ 0 & 1 & 1 & 0 \end{pmatrix}$$



$$[M_{vv}^2] = \begin{pmatrix} 0 & 10 & 11 & 0 \\ 10 & 0 & 0 & 2 \\ 11 & 0 & 0 & 0 \\ 0 & 2 & 0 & 0 \end{pmatrix}$$



$$[M_{vv}^3] = \begin{pmatrix} 0 & 10 & 10 & 1 \\ 10 & 0 & 1 & 1 \\ 10 & 1 & 0 & 0 \\ 1 & 1 & 0 & 0 \end{pmatrix}$$

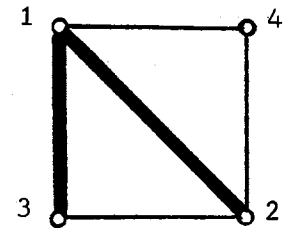


Figure 13. Subgraphs and Two-Colored Graphs Obtained from  $\begin{pmatrix} 1212 \\ 2110 \end{pmatrix}$

The superpositions of the incidence matrices of two subgraphs are then the final v-v incidence matrices for the 2-colored graph specification  $\begin{bmatrix} 1212 \\ 2110 \end{bmatrix}$ . It should be noted that the elements of the incidence matrices for the colored-2 specification [2110] are to be multiplied by 10, since they represent another type of colored edge.

$$[M_{vv}^1] = [M_{vv}^1]_1 + 10 [M_{vv}^1]_2$$

$$[M_{vv}^2] = [M_{vv}^2]_1 + 10 [M_{vv}^1]_2$$

$$[M_{vv}^3] = [M_{vv}^3]_1 + 10 [M_{vv}^1]_2$$

The three 2-colored graphs and their v-v incidence matrices have been shown on page 52.

#### Cut-Set Matrix with Modulo-2 Operation

In this section, a method called cut-set matrix with modulo-2 operation is presented to enumerate the colored graphs with trees. The method used is developed by Malik and Lee [60]. The principal advantages of this method are its compact notations and a high degree of organization. The method organizes the tree-finding problem in such a manner that it lends itself to determine the subsets of the set of trees of a graph. For example, it permits one to find the set of all trees which contain only a given set of edges.

The fundamental system of cut-sets with respect to a tree T is the set of v-1 cut-sets (v is number of vertices), one for each branch, in which each cut-set includes exactly one branch of T. The cut-set matrix of distance 1 is an array of b x c where b is the number of branches or number of cut-sets and c is the number of chords in a graph.

The element  $a_{ij}$  of the cut-set matrix of distance 1 is 1 if chord  $j$  is incident with branch  $i$ , otherwise,  $a_{ij} = 0$ . The cut-set matrix of distance  $i$  is an array of  ${}^b C_i \times {}^c C_i$ , where  ${}^b C_i$  and  ${}^c C_i$  are the  $i$ -combination of  $b$  things and  $i$ -combination of  $c$  things respectively. If  $b$  is greater than or equal to  $c$ , the maximal distance of the cut-set matrix is  $c$ , otherwise, the maximal distance of the cut-set matrix is  $b$ . The element of the cut-set matrix with distance greater than one is the determinant of the corresponding submatrix of the cut-set matrix with distance 1.

Given a starting tree, the cut-set matrices with distance  $k$  can be formed. The total possible number of trees is then equal to the sum of the number of the element 1's in the cut-set matrices with different distances and the starting tree. An example is shown to illustrate the application of this method.

Example 3-5 Find all the other number of tree graphs from the starting graph shown in Fig. 14.

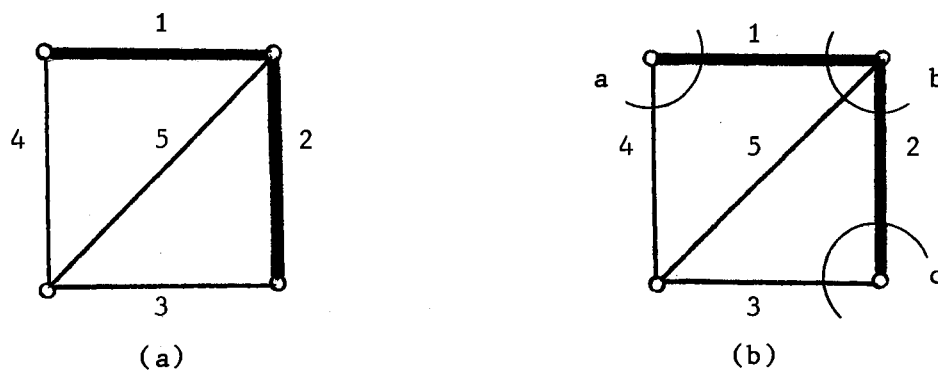


Figure 14. Graph and Its Cut-Sets

Solution: A graph with a tree should satisfy the following two equations:

$$c = e - v + 1 \quad (3-6)$$

$$b = v - 1 \quad (3-7)$$

where

- c: number of chords in a graph.
- b: number of branches in a graph.
- e: number of edges in a graph.
- v: number of vertices in a graph.

Let the starting tree be T which contains branches 3,4,5 of the given graph as shown in Fig. 14 (a). Therefore, if the cut-sets a,b,c are chosen as shown on page 54, then the cut-set matrices of distances one and two are obtained as follows.

$$Q^{(1)} = \begin{matrix} & \begin{matrix} 1 & 2 \end{matrix} \\ \begin{matrix} 3 \\ 4 \\ 5 \end{matrix} & \begin{bmatrix} 0 & 1 \\ 1 & 0 \\ 1 & 1 \end{bmatrix} \end{matrix} \quad Q^{(2)} = \begin{matrix} & 12 \\ \begin{matrix} 34 \\ 35 \\ 45 \end{matrix} & \begin{bmatrix} 1 \\ 1 \\ 1 \end{bmatrix} \end{matrix}$$

The algebra of the field modulo-2 was used to find the entries of cut-set matrix of distance 2,  $Q^{(2)}$ . The basic modulo-2 operation is listed below:

$$\left. \begin{array}{l} 1 + 1 = 0 \\ 1 + 0 = 1 \end{array} \right] \quad \text{exclusive or}$$

$$\left. \begin{array}{l} 1 \times 1 = 1 \\ 1 \times 0 = 0 \\ 0 \times 0 = 0 \end{array} \right] \quad \text{and}$$

For example, the entry (34, 12) in  $Q^{(2)}$  is obtained by finding the determinant.

$$D = \begin{matrix} & \begin{matrix} 1 & 2 \end{matrix} \\ \begin{matrix} 3 \\ 4 \end{matrix} & \begin{bmatrix} 0 & 1 \\ 1 & 0 \end{bmatrix} \end{matrix} = 0 \times 0 + 1 \times 1 = 0 + 1 = 1$$



A non-zero entry such as the entry (3,2) of  $Q^{(1)}$  corresponds to the tree 245 of distance one which is obtained by replacing branch 3 by chord 2 as shown in Fig. 15 (b). Using this procedure, the other three trees of distance one from T are found to be: 315, 341, 342.

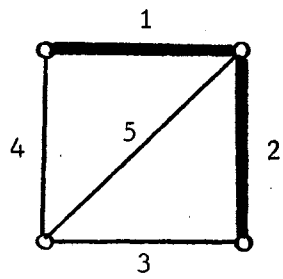
Similarly, from  $Q^{(2)}$ , the three trees of distance two are found to be: 512, 412, 312.

Therefore, the complete set of trees of the graph are the eight trees listed above including the starting tree T shown in Fig. 15 (a).

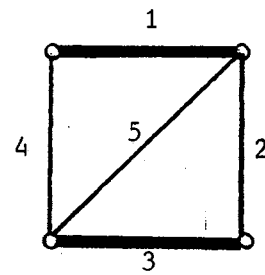
It should be noted that among the eight graphs with trees, there are only three graphs which are non-isomorphic to each other, they are

1. (a) = (f)
2. (b) = (c)
3. (d) = (e) = (g) = (h)

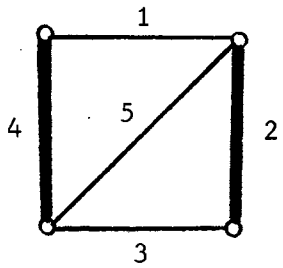
The graph isomorphism test is presented in the next chapter.



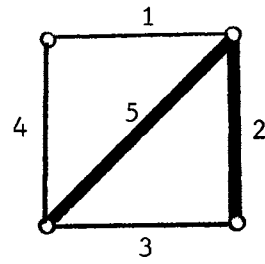
(a) T: 345



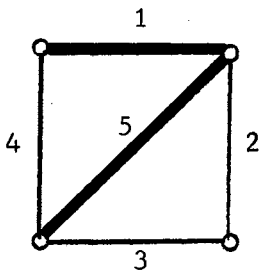
(b) 245



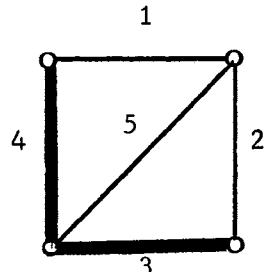
(c) 315



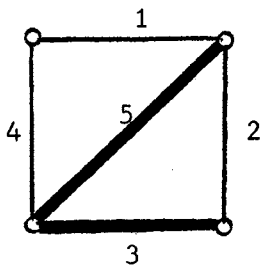
(d) 341



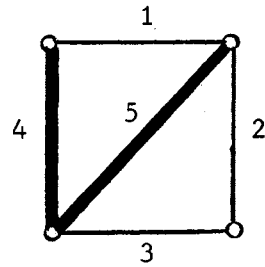
(e) 342



(f) 512



(g) 412



(h) 312

Figure 15. Graphs with Complete Set of Trees

## CHAPTER IV

### ALGORITHM OF COLORED GRAPH ISOMORPHISM TEST

Two graphs are isomorphic, if and only if the vertices and edges of the two graphs can be placed in one-to-one correspondence and the incidences are preserved.

Unger [61] showed a heuristic method for a pair of directed linear graphs. The procedures attempt to express the inward and outward degrees of vertices and the partitioning, on the basis of degrees of vertices, for possible matches. The method is able to handle a fairly complex graphs in a relatively short time, but may not work in all cases due to its heuristic nature.

Goodman and Cummins presented a method to determine whether or not two linear graphs are isomorphic and listed the automorphisms of a graph [62,63]. The method partitioned the vertices of any graph into degree classes in which all vertices in a class have the same degree. These classes are used to define connected subgraphs which can be treated directly. The logical expression for proposition and logical product of two propositions are explored to determine the vertex elementary matrices. The graph transformation equation in terms of vertex-vertex incidence matrices and elementary matrices is used to check for isomorphism.

Following the similar steps proposed by Unger, Dobrjanskyj [34,35]

presented a systematic procedure to determine the isomorphism of a pair of non-directed graphs. The incidence tables are used to check for the local incidence relations between vertices and edges of the graphs. The vertex and edge correspondence matrices are obtained in matrix form and graph transformation equation in terms of vertex-edge incidence matrices and correspondence matrices is used to check for isomorphism. Because of lack of efficient deterministic procedures in which no finite number of isomorphic possibilities are shown, the algorithm has led to insufficient computer procedures.

Cornell and Gotlieb [64,65] showed a procedure for determining whether two graphs are isomorphic. The representative and the recorded graphs are derived from the given graphs. The representative graphs form a necessity condition for isomorphism; namely, if they are not identical, then the given graphs are not isomorphic. The recorded graphs form a sufficiency condition for isomorphism; namely, if they are identical, then the given graphs are isomorphic. In the algorithm, only undirected, unlabeled graphs are considered. The procedure is not deterministic, since it is based upon a conjecture.

Similar to the problem of graph isomorphism test, a method concerned with the computer search for non-isomorphic convex polyhedra has been developed by Grace [66].

In this chapter, the procedures for isomorphism test are developed. These procedures take into account the linear or non-linear non-directed graphs with different types of colored edges and colored vertices. The graph transformation equation and incidence tables are used and the total number of isomorphic possibilities are determined. The proposed procedures are proved to provide the necessary and sufficient

conditions for the isomorphism test. A general computer program and two sample outputs are presented in Program C, Appendix B.

### Isomorphism Test for Linear and Non-linear Colored Graphs

In Chapter II, the formation of v-v incidence matrix for a colored graph with different colored edges is presented. The element of the v-v incidence matrix is  $a_{ij} = xy$  (digit number) where the number of places of the digit number is the number of types of edges in a graph. The vertex-edge (v-e) incidence matrix which can be obtained by assigning the edge numbers on the non-zero entries of v-v incidence matrix is to be used to test the graph isomorphism. The element of the v-e incidence matrix is still  $a_{ij} = xy$ . Besides the identification of different types of edges, the vertices are also to be identified by a digit number  $t$ , where  $t$  represents the type of vertex:  $t = 1$  for fine vertex representing rigid link;  $t = 2$  for vertex representing piston-cylinder;  $t = 3$  for vertex representing spring;  $t = 4$  for vertex representing pulley and  $t = 5$  for vertex which represents the fixed link in mechanism. Let the sum of row  $i$  of v-v (or v-e) incidence matrix be  $V_i = dv$  which is the degree of vertex  $i$ , then the new representation of degree of vertex  $i$  is  $V_i = tdv$  which takes into account the type of vertex.

Definition 1: Graphs  $G_1 = (V_1, E_1)$  and  $G_2 = (V_2, E_2)$  are said to be isomorphic to each other if there exists 1-1 correspondence between  $V_1$  and  $V_2$  and between  $E_1$  and  $E_2$  which preserves incidences (adjacency properties).

Definition 2: Two incidence matrices are equivalent, if they are different only by permutations of rows and columns.

Theorem 1: If two graphs  $G_1$  and  $G_2$  are isomorphic, then there exist two elementary matrices of rank  $v$  and  $e$ , such that the incidence matrices of the graphs are transformed by the following transformation equation.

$$[M_{ve}^1] = [E_v] [M_{ve}^2] [E_e] \quad (4-1)$$

where  $[M_{ve}^1]$ ,  $[M_{ve}^2]$ : vertex-edge incidence matrices of  $G_1$  and  $G_2$  respectively.

$[E_v]$ : vertex elementary matrix with the order of  $n_v^1$  by  $n_v^2$ .

( $n_v$ : number of vertices in a graph)

$[E_e]$ : edge elementary matrix with the order of  $n_e^2$  by  $n_e^1$ .

( $n_e$ : number of edges in a graph)

Proof: If two graphs are isomorphic, then there exists one-to-one correspondence between their vertices and edges, and the incidences are preserved [Definition 1]. If the correspondence of vertices and edges in two graphs is expressed in matrix form, then  $[E_v]$  and  $[E_e]$  are obtained.

The permutations of columns and rows in a v-e incidence matrix is equivalent to the relabelling of edges and vertices in the graph. If  $[M_{ve}^2]$  is postmultiplied by  $[E_e]$ , then columns of  $[M_{ve}^2]$  are permuted according to the edge incidences of  $G_1$  and  $G_2$ .

$$[m_{ve}^2] [E_e] = [T]$$

Therefore, v-e incidence matrix  $[T]$  expresses the adjacency properties of vertices in  $G_2$  and edges in  $G_1$ . If  $[T]$  is premultiplied by  $[E_v]$ , then rows of  $[T]$  are permuted according to the vertex incidences of  $G_1$  and  $G_2$  and the resultant v-e incidence matrix expresses

the adjacency properties of vertices and edges in  $G_1$ , that is,  $[M_{ve}^1]$  as shown in the left side of Eq. (4-1).

Matrices  $[E_v]$  and  $[E_e]$  relate the correspondence of vertices and edges respectively in graph 1 and graph 2. Since  $[M_{ve}^1]$  and  $[M_{ve}^2]$  are known, the determination of  $[E_v]$  and  $[E_e]$  is then the main part of the problem of graph isomorphism test.

The procedures to find  $[E_v]$  and  $[E_e]$  and to check graph isomorphism are described below:

Step 1: Check the number of vertices and edges of two graphs, if they are the same, go to step 2, if not, the two graphs are not isomorphic.

Step 2: Check the degrees of vertices of both graphs, if they are not equivalent, then the two graphs are not isomorphic, if they are equivalent, go to step 3.

Step 3: Let the number of different degrees of vertices be  $d$ , and the number of vertices having the same degree of vertex be  $m_i$ , where  $i = 1, \dots, d$ , then the total number of possibilities for the vertices of graph 1 to be correspondent to the vertices of graph 2 is

$$n = \prod_{i=1}^d (m_i!) \quad (\prod: \text{product})$$

That is, there are  $n$  possible ways to form the vertex elementary matrix  $[E_v]$ .

Step 4: Pick up one possibility of vertex correspondence from step 3 and form the  $[E_v]$ .

Step 5: Let the two vertices corresponding to each entry 1 in  $[E_v]$  be the leading vertices and form the incidence tables.

Step 6: If the degrees of vertices of two graphs in the incidence tables are not the same, go to step 4 and repeat. Otherwise, find the edge correspondence in the two graphs, and fill out the corresponding entries in  $[E_e]$  by 1's.

Step 7: Repeat step 5, step 6 until  $[E_e]$  is completely filled out such that in each row and each column, there is only one entry with 1.

Step 8: Check by Eq. (4-1), if it is satisfied, the two graphs are isomorphic. Otherwise, go to step 4 and repeat. If all the possibilities have been tried out and no isomorphism is found, then the two graphs are not isomorphic.

Theorem 2: The procedures described above provide the necessary and sufficient conditions for the colored graph isomorphism test.

Proof:

1. The types of colored edges in the graph are expressed in the elements of v-v or v-e incidence matrix. The types of colored vertices are identified in the degrees of vertices.
2. The degrees of vertices of both graphs provide the necessary condition for checking graph isomorphism. If the degrees of vertices of both graphs are not equivalent, they are not isomorphic since there exists no one-to-one correspondence between the vertices of both graphs [Definition 1]. If they are equivalent, there exists a finite number of isomorphic possibilities as described below.
3. The finite number of isomorphic possibilities for the vertices in two graphs to be correspondent is equal to

$$n = \prod_{i=1}^d (m_i!) \quad (\prod: \text{product})$$



where

$n$ : finite number of isomorphic possibilities.

$d$ : the number of different degrees of vertices in the graph.

$m_i$ : the number of vertices having the same degree of vertex,  $i = 1, \dots, d$ .

4. For each isomorphic possibility, there exists one-to-one correspondence between the vertices of both graphs, therefore, the vertex elementary matrix  $[E_v]$  is completed.
5. By letting the two corresponding vertices in two graphs be the leading vertices respectively, the incidence tables of two graphs provide the adjacency properties of vertices and edges (developed from the leading vertices) in two graphs respectively.
6. If the degrees of vertices of two graphs in the incidence tables are not equivalent, then the isomorphic possibility has to be rejected, because no adjacency properties of the vertices and edges are found. In this case, the next isomorphic possibility is used and the procedures are repeated. If all the isomorphic possibilities are used and the degrees of vertices of two graphs in the incidence tables are still not equivalent, the two graphs are not isomorphic.
7. If the degrees of vertices of two graphs in the incidence tables are equivalent, the edge correspondence in two graphs is found according to the exist vertex correspondence. The corresponding entries in edge elementary matrix  $[E_e]$  are filled by 1's. The entry 1 shows one-to-one correspondence between corresponding two edges in two graphs.
8. The procedures to form the incidence tables from other leading

vertices are continued until  $[E_e]$  is completed such that only one entry with 1 appears on each column and each row.

9. Since  $[E_e]$  is completed and  $[E_v]$  is known for each isomorphic possibility, the graph transformation equation

$$[M_{ve}^1] = [E_v] [M_{ve}^2] [E_e]$$

is to be checked. If the equation is satisfied, the two graphs are isomorphic [Theorem 1]. If it is not satisfied, the next isomorphic possibility has to be used and procedures repeated. If all the isomorphic possibilities are tested and no isomorphism is found, then the two graphs are not isomorphic.

10. The degrees of vertices of two graphs provide the necessary condition to check graph isomorphism. The finite number of isomorphic possibilities and graph transformation equation provide the sufficient condition to check graph isomorphism. Therefore, the whole procedures described provide the necessary and sufficient conditions for graph isomorphism test.

Example 4-1 Test the two graphs shown in Fig. 16 to determine if they are isomorphic.



Figure 16. Two Linear Two-Colored Graphs

The two v-v incidence matrices of graph 1 and graph 2 are shown below respectively.

$$[M_{vv}^1] = \begin{pmatrix} 0 & 10 & 0 & 0 & 1 \\ 10 & 0 & 1 & 10 & 0 \\ 0 & 1 & 0 & 1 & 10 \\ 0 & 10 & 1 & 0 & 1 \\ 1 & 0 & 10 & 1 & 0 \end{pmatrix} \quad [M_{vv}^2] = \begin{pmatrix} 0 & 1 & 0 & 10 & 1 \\ 1 & 0 & 1 & 0 & 10 \\ 0 & 1 & 0 & 10 & 0 \\ 10 & 0 & 10 & 0 & 1 \\ 1 & 10 & 0 & 1 & 0 \end{pmatrix}$$

By assigning the edge numbers on the non-zero entries of  $[M_{vv}^1]$  and  $[M_{vv}^2]$ , the two vertex-edge incidence matrices are obtained as follows.

$$[M_{ve}^1] = \begin{pmatrix} 10 & 1 & 0 & 0 & 0 & 0 & 0 \\ 10 & 0 & 1 & 10 & 0 & 0 & 0 \\ 0 & 0 & 1 & 0 & 1 & 10 & 0 \\ 0 & 0 & 0 & 10 & 1 & 0 & 1 \\ 0 & 1 & 0 & 0 & 0 & 10 & 1 \end{pmatrix}, \quad [M_{ve}^2] = \begin{pmatrix} 1 & 10 & 1 & 0 & 0 & 0 & 0 \\ 1 & 0 & 0 & 1 & 10 & 0 & 0 \\ 0 & 0 & 0 & 1 & 0 & 10 & 0 \\ 0 & 10 & 0 & 0 & 0 & 10 & 1 \\ 0 & 0 & 1 & 0 & 10 & 0 & 1 \end{pmatrix}$$

The entries 10 and 1 designate the incidence of a heavy edge with a vertex and a fine edge with a vertex respectively; while entry 0 designates no incidence of an edge with a vertex.

The degrees of vertices of each graph are listed below:

Graph	Vertex	Degree of Vertex
1	1	111
	2	121
	3	112
	4	112
	5	112
2	1	112
	2	112
	3	111
	4	121
	5	112

The degree of vertex 1 in graph 2 is equal to the sum of the first row of  $[M_{ve}^2]$ , that is, 12, and preceded by the type of vertex 1, that is, 1.

There are one 111, one 121, and three 112's in the degrees of vertices in each of the graphs, therefore, there are  $1! \times 1! \times 3! = 6$  possibilities for the vertices in graph 1 and graph 2 to be correspondent. Let us pick up one of the possibilities as shown below.

Graph	Vertex	Degree of Vertex	Vertex	Graph
1	1	111	3	2
	3	112	5	
	4	112	1	
	5	112	2	
	2	121	4	

The entries 13, 35, 41, 52 and 24 in  $[E_v]$  are then to be filled by 1's as shown at the end of example.

Let us pick up the vertices  $v_1^1$  and  $v_3^2$  as the leading vertices for the following incidence table, then

(a)	$v_1^1$ :	$e_2$	$e_1$	$v_3^2$ :	$e_4$	$e_6$
		$v_5$	$v_2$		$v_2$	$v_4$
		112	121		112	121

The first row of the incidence table is the list of edges incident with the leading vertex, the second row is the list of vertices

which are at the other end of the edges listed in the first row. The third row is the list of degrees of vertices for those vertices shown in second row.

Judging from the incidence table (a) and the vertex correspondence in  $[E_v]$ , we obtain the following edge correspondence:

$$\begin{aligned} e_4^2 &= e_2^1 \\ e_6^2 &= e_1^1 \end{aligned}$$

Therefore, the entries 42 and 61 of  $[E_e]$  are to be filled by 1's.

Let us pick up the vertices  $v_3^1$  and  $v_5^2$  as the leading vertices for another incidence table shown below:

(b)	$v_3^1$ :	$e_3$	$e_5$	$e_6$	$v_5^2$ :	$e_7$	$e_3$	$e_5$
		$v_2$	$v_4$	$v_5$		$v_4$	$v_1$	$v_2$
		121	112	112		121	112	112

Judging from the incidence table (b) and the vertex correspondence in  $[E_v]$ , we obtain the following edge correspondence:

$$\begin{aligned} e_7^2 &= e_3^1 \\ e_3^2 &= e_5^1 \\ e_5^2 &= e_6^1 \end{aligned}$$

Therefore, the entries 73, 35, 56 of  $[E_e]$  are to be filled by 1's.

Let us pick up vertices  $v_4^1$  and  $v_1^2$  as the leading vertices for the following incidence table:

(c)	$v_4^1$ :	$e_5$	$e_7$	$e_4$	$v_1^2$ :	$e_3$	$e_1$	$e_2$
		$v_3$	$v_5$	$v_2$		$v_5$	$v_2$	$v_4$
		112	112	121		112	112	121

Judging from the incidence table (c) and the correspondence in  $[E_v]$  and  $[E_e]$ , we obtain the following new edge correspondence for  $[E_e]$

$$\begin{aligned} e_1^2 &= e_7^1 \\ e_2^2 &= e_4^1 \end{aligned}$$

After filling out the entries 17 and 24 of  $[E_e]$ , the procedures are completed. The vertex and edge elementary matrices  $[E_v]$  and  $[E_e]$  are shown as follows.

$$[E_v] = \begin{pmatrix} 0 & 0 & 1 & 0 & 0 \\ 0 & 0 & 0 & 1 & 0 \\ 0 & 0 & 0 & 0 & 1 \\ 1 & 0 & 0 & 0 & 0 \\ 0 & 1 & 0 & 0 & 0 \end{pmatrix} \quad [E_e] = \begin{pmatrix} 0 & 0 & 0 & 0 & 0 & 0 & 1 \\ 0 & 0 & 0 & 1 & 0 & 0 & 0 \\ 0 & 0 & 0 & 0 & 1 & 0 & 0 \\ 0 & 1 & 0 & 0 & 0 & 0 & 0 \\ 0 & 0 & 0 & 0 & 0 & 1 & 0 \\ 1 & 0 & 0 & 0 & 0 & 0 & 0 \\ 0 & 0 & 1 & 0 & 0 & 0 & 0 \end{pmatrix}$$

After checking the Eq. (4-1), we have

$$[M_{ve}^2] [E_e] = \begin{pmatrix} 0 & 0 & 0 & 10 & 1 & 0 & 1 \\ 0 & 1 & 0 & 0 & 0 & 10 & 1 \\ 10 & 1 & 0 & 0 & 0 & 0 & 0 \\ 10 & 0 & 1 & 10 & 0 & 0 & 0 \\ 0 & 0 & 1 & 0 & 1 & 10 & 0 \end{pmatrix}$$

$$[E_v] [M_{ve}^2] [E_e] = \begin{pmatrix} 10 & 1 & 0 & 0 & 0 & 0 & 0 \\ 10 & 0 & 1 & 10 & 0 & 0 & 0 \\ 0 & 0 & 1 & 0 & 1 & 10 & 0 \\ 0 & 0 & 0 & 10 & 1 & 0 & 1 \\ 0 & 1 & 0 & 0 & 0 & 10 & 1 \end{pmatrix} = [M_{ve}^1]$$

Since Eq. (4-1) is satisfied, graph 1 and graph 2 are isomorphic.

Example 4-2 Test the two graphs shown in Fig. 17 to determine if they are isomorphic.

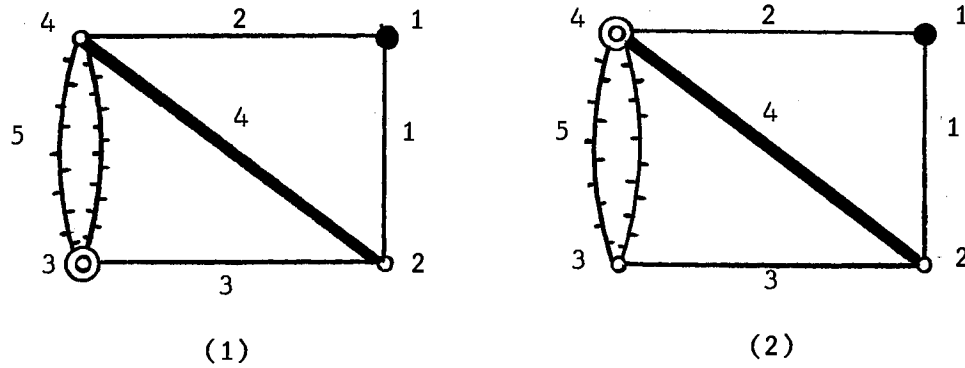


Figure 17. Two Non-Linear Three-Colored Graphs

The upper triangles of v-v incidence matrices of graph 1 and graph 2 are shown below respectively.

$$[M_{vv}^1] = \begin{bmatrix} 0 & 1 & 0 & 1 \\ 1 & 0 & 1 & 10 \\ 0 & 1 & 0 & 200 \\ 1 & 10 & 200 & 0 \end{bmatrix} \quad [M_{vv}^2] = \begin{bmatrix} 0 & 1 & 0 & 1 \\ 1 & 0 & 1 & 10 \\ 0 & 1 & 0 & 200 \\ 1 & 10 & 200 & 0 \end{bmatrix}$$

By assigning the edge numbers on the non-zero entries of  $[M_{vv}^1]$  and  $[M_{vv}^2]$ , the two vertex-edge incidence matrices are obtained as follows.

$$[M_{ve}^1] = \begin{bmatrix} 1 & 1 & 0 & 0 & 0 \\ 1 & 0 & 1 & 10 & 0 \\ 0 & 0 & 1 & 0 & 200 \\ 0 & 1 & 0 & 10 & 200 \end{bmatrix} \quad [M_{ve}^2] = \begin{bmatrix} 1 & 1 & 0 & 0 & 0 \\ 1 & 0 & 1 & 10 & 0 \\ 0 & 0 & 1 & 0 & 200 \\ 0 & 1 & 0 & 10 & 200 \end{bmatrix}$$

The degrees of vertices of each graph are listed below:

Graph	Vertex	Degree of Vertex
1	1	2002
	2	1012
	3	4201
	4	1211
2	1	2002
	2	1012
	3	1201
	4	4211

Since the degrees of vertices in graph 1 and graph 2 are not equivalent, the two graphs are not isomorphic.



## CHAPTER V

### COMPUTER METHODS OF LISTING SPECIFICATIONS, SYNTHESIZING INCIDENCE MATRICES AND TESTING ISOMORPHISM OF COLORED GRAPHS

In Chapter III, the definition and equation of colored graph specifications are introduced. It has also been shown that the number of rows of the specification is equal to the number of different types of colored edges and also equal to the number of subgraphs. Following the introduction of colored graph specifications, the procedures to synthesize the v-v incidence matrices of linear and non-linear colored graphs from a given specification are presented. In Chapter IV, a general algorithm is introduced to test the isomorphism of linear and non-linear colored graphs. The total number of possibilities of finding the graph isomorphism is also described.

In this chapter, the computer methods of listing the specifications, synthesizing the incidence matrices and testing the graph isomorphism are described and their corresponding computer programs are listed in programs A, B and C in Appendix B.

#### Listing of Colored Graph Specifications

Program A in Appendix B is for the listing of specifications. The program distributes the number NB into NP places. The lower bound and upper bound of the specifications are denoted as ML and MU respectively. Any specification which has number either less than ML or greater than

MU is rejected. The computer program written in Fortran IV language consists of one main program and three subroutines.

Example 1 shown in Program A output has  $NB = 14$ ,  $NP = 6$ ,  $ML = 1$  and  $MU = 9$ . Such a set of specification will yield a graph with 6 vertices and 7 edges ( $NB = 2 \times$  number of edges of a graph). A total of 20 specifications is generated. Example 2 shows a listing of 2-colored graph specifications. The colored-1 subgraph has  $NB = 6$ ,  $NP = 4$ ,  $ML = 1$  and  $MU = 3$ . The colored-2 subgraph has  $NB = 4$ ,  $NP = 4$ ,  $ML = 0$  and  $MU = 2$ . These data can be interpreted as a colored graph having 4 vertices, 3 fine edges and 2 heavy edges. There are total 14 specifications generated.

#### Synthesis of Vertex-Vertex Incidence Matrices

Program B in Appendix B is to synthesize the v-v incidence matrices of colored graphs. The given data are the number of vertices and the specification of the colored graph. The program is written for the general purpose which takes into account any number of vertices and any number of different types of colored edges. The input data of the specification can be read in by arbitrary order.

Two examples are shown in the output of Program B. Example 1 shows one colored graphs having four vertices with the specification  $[3322]$ . Four v-v incidence matrices are generated from the given specification. The corresponding graphs have one linear and three non-linear graphs which are shown in the output. Example 2 is the problem of synthesizing two-colored graphs with the specification  $\begin{bmatrix} 1212 \\ 2110 \end{bmatrix}$ . The colored-1 subgraphs are first found from the specification  $[1212]$ , and the colored-2 subgraph are then found from the specification

[2110]. The superpositions of both subgraphs are the final v-v incidence matrices of the two-colored graphs with  $\begin{bmatrix} 1212 \\ 2110 \end{bmatrix}$ . One linear two-colored graph and two non-linear two-colored graphs are obtained and shown in the output.

The computer program consists of one main program and five sub-routines. They are all written in Fortran IV language.

#### Colored Graph Isomorphism Test

Program C which consists of one main program and five subroutines is developed to test the colored graph isomorphism. The program takes into account both linear and non-linear colored graphs with any numbers of different types of vertices and edges.

The types of edges and vertices of the colored graph are represented by some digit numbers which are described in Chapter IV.

The elements in upper triangle of the v-v incidence matrix of each colored graph are the main input data. The preparation of the data cards for the program is explained in Appendix B.

Two examples are shown in the output of the program. Example 1 shows two two-colored graphs having 6 vertices, 6 fine edges and 2 heavy edges with the v-v incidence matrices shown in the output. All the possibilities of finding isomorphism and incidence tables are printed out. The two graphs have been shown as isomorphic to each other. Example 2 shows two 3-colored graphs with three different types of vertices. The two graphs have been shown as non-isomorphic, since they have the different sets of degrees of vertices.

## CHAPTER VI

### GRAPHICAL REPRESENTATIONS, MOBILITY EQUATIONS AND CRITERIA OF KINEMATIC CHAINS WITH DIFFERENT KINEMATIC ELEMENTS

The methods of graphical representations of kinematic chains with different kinematic elements such as cam pairs, prism pairs, gear pairs, springs, belt-pulleys and their combinations are presented in this chapter. The enumerations of those kinematic chains with different kinematic elements and their combinations then become the problems of enumerating the different colored graphs with colored vertices and colored edges. Some enumerations of colored graphs are shown and are verified by the Polya's theory of counting. Mobility equations in terms of colored vertices and colored edges are developed for kinematic chains with different kinematic elements. One general mobility equation is developed which takes into account any number of colored vertices and colored edges. Since not all colored graphs synthesized are accepted from the point of  $F$  degrees of freedom<sup>1</sup>, criteria are developed to reject those unacceptable colored graphs.

---

<sup>1</sup>Isokinetic chain of  $F$  degrees of freedom is defined as a kinematic chain in which there exists no assembly of links and joints, which when considered alone would form a kinematic chain with less than  $F$  degrees of freedom [32].

## Cam Kinematic Chains

In any kinematic chain, a binary link and its two turning joints can be replaced by a cam pair. Fig. 18 shows Watt's six-link chain and its corresponding graph in which rigid links and turning joints are represented by vertices and edges respectively. A cam kinematic chain (CKC) with one cam pair can be obtained from Fig. 18 (b) by replacing fine edges 12, 23 by a heavy edge 13 as shown in Fig. 19 (b). The corresponding CKC is shown in Fig. 19 (a).

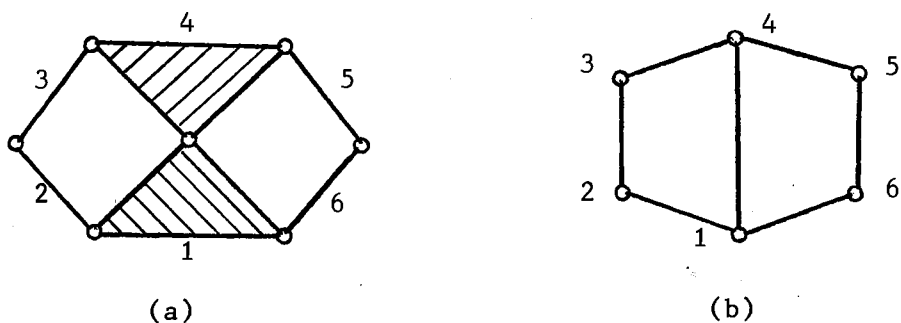


Figure 18. Watt's Six-Link Chain and Its Corresponding Graph

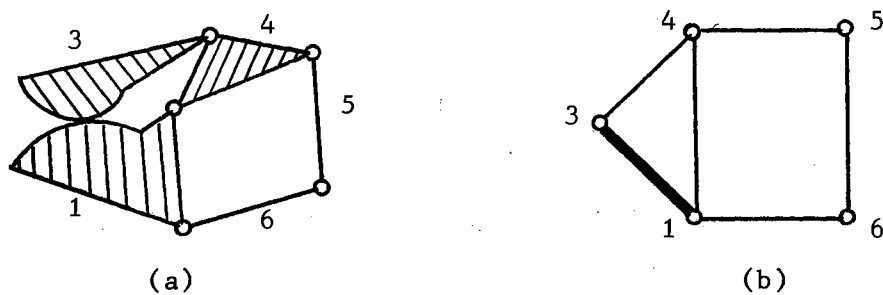


Figure 19. CKC with One Cam Pair and Its Colored Graph

From the procedure of constructing cam kinematic chains, two equations can be established to relate the number of turning joints and links in the parent kinematic chain to the number of vertices, fine and heavy edges in the colored graph.

$$j = e_f + 2e_h \quad (6-1)$$

$$l = v + e_h \quad (6-2)$$

where

$j$ : number of turning joints in the parent kinematic chain.

$l$ : number of links in the parent kinematic chain.

$e_f$ : number of fine edges in colored graph.

$e_h$ : number of heavy edges in colored graph.

$v$ : number of vertices in colored graph.

For example, there are 6 links and 7 joints in the parent Watt's chain shown in Fig. 18 (a) and there are 5 vertices, 5 fine edges and 1 heavy edge in the colored graph as shown in Fig. 19 (b), therefore

$$7 = 5 + 2 \quad (1)$$

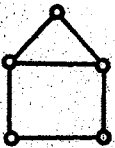
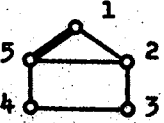
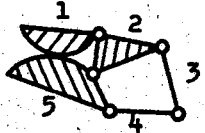
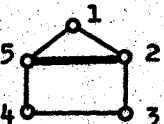
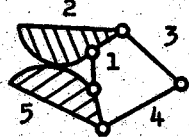
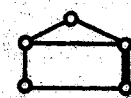

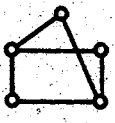
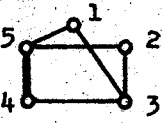
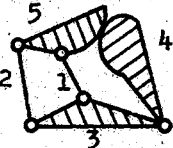
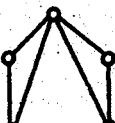
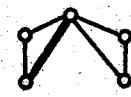

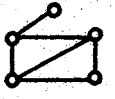
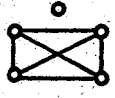
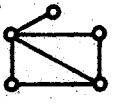
$$6 = 5 + 1$$

The number of linear graphs having 5 vertices and 6 edges (including fine and heavy edges) can be obtained from the coefficient of  $x^6 y^4$  of the cycle index of full-pair group,  $R_5(x,y)$ , and is equal to 6 [57]. Table VI shows all the 6 linear graphs having 5 vertices and 6 edges, the colored graphs and CKC. Some of the graphs are rejected using the following rules:

Rule 1: Non-connected graph is rejected. If a kinematic chain is open, its corresponding graph is non-connected, that is, at least one

TABLE VI

ALL THE 6 LINEAR GRAPHS HAVING 5 VERTICES  
AND 6 EDGES, COLORED GRAPHS AND CKC

Linear Graphs	Unequivalent Colored Graphs	Corresponding CKC	Comment
<p>1.</p> 	<p>a.</p> 		<p>The parent chain is Watt's kinematic chain.</p>
	<p>b.</p> 		<p>The parent chain is Stephenson's kinematic chain.</p>
	<p>c.</p> 		<p>Rejected! (Rule 2)</p>
	<p>d.</p> 		<p>Rejected! (Rule 2)</p>
<p>2.</p> 	<p>e.</p> 		<p>The parent chain is Stephenson's kinematic chain.</p>
<p>3.</p> 	<p>f.</p> 		<p>Rejected! (Rule 2)</p>
	<p>g.</p> 		<p>Rejected! (Rule 2)</p>
<p>4.</p> 			<p>Rejected! (Rule 1)</p>
<p>5.</p> 			<p>Rejected! (Rule 1)</p>
<p>6.</p> 			<p>Rejected! (Rule 1)</p>

of the degrees of vertices in the linear graph is less than two, or the degree of vertex at the end of the double-edge of the non-linear graph is equal to 2.

Rule 2: A graph having a circuit which consists of three fine vertices and three fine edges is rejected. The kinematic chain corresponding to this kind of graph is non-isokinetic. Part of the chain when considered alone would form a kinematic chain with less than 1 degree of freedom. It has no mobility.

Rule 3: Neither linear nor non-linear graph can have more than three consecutive vertices with degrees of vertices 2 in terms of fine edges. The kinematic chain becomes non-isokinetic in this case.

Rule 4: A non-linear graph with double-edges in which each double-edge has one heavy edge and one fine edge is rejected. Since between two cam surfaces, only cam pair(s) is possible to exist, no turning joints can exist at the same time.

Rule 5: A non-linear graph with multiple-edges is rejected if there are more than two edges in each multiple-edge. In general, the kinematic chain corresponding to this kind of graph has no mobility. Under some special geometric conditions<sup>2</sup>, a CKC corresponding to a non-linear colored graph with multiple heavy edges may have constrained motion.

---

<sup>2</sup>In this case, the relative motion between two cams is either pure rotation or pure translation.



For the parent kinematic chain with 6 links and 7 turning joints, the number of vertices and edges in a graph required for CKC with two cam pairs (two heavy edges) can be computed from Eqs. (6-1) and (6-2) and are equal to 4 and 5 respectively. The number of linear graphs having 4 vertices and 5 edges is equal to 1, also equal to the coefficient of  $x^5 y$  of the cycle index of the full pair group,  $R_4(x, y, z)$  in Eq. (2-16). Table VII shows the linear graph having 4 vertices and 5 edges, colored graphs and CKC.

Table VIII shows the non-linear graphs and CKC developed from the parent 6 link chain. The number of non-linear graphs can be verified by the Polya's theory of counting. The number of non-linear graphs having 4 vertices, 1 double-edge and 3 fine edges is equal to the coefficient of  $x^3 y^2 z$  in the cycle index of the full-pair group,  $R_4(x, y, z)$  as shown in Eq. (2-16) and is equal to 4. Similarly, the number of non-linear graphs having 3 vertices, 1 double-edge and 2 fine edges is equal to the coefficient of  $x^2 z$  in  $R_3(x, y, z)$  and is equal to 1. Note that  $R_3(x, y, z)$  can be obtained by substituting  $t_i = x^i + y^i + z^i$  into the cycle index of the permutation group shown in Example 2-2, Chapter 2. It should be noted that the cycle index of the full-pair group of 3 objects is the same as the cycle index of the symmetrical group of 3 objects.

From Eqs. (6-1) and (6-2), if we let  $l = 10$ ,  $j = 13$  and  $e_h = 6$ , we obtain  $v = 4$ ,  $e_f = 1$ , that is, the CKC with 6 cam pairs developed from parent 10 link chain will have the colored graphs consisting of 4 vertices and 7 edges. Since the number of edges of a complete graph with 4 vertices is equal to  $\frac{1}{2}(4)(4-1) = 6$ , the colored graphs consist of at least one double-edge. All the graphs having 4 vertices

TABLE VII

ONE LINEAR GRAPH HAVING 4 VERTICES, 5 EDGES,  
COLORED GRAPHS AND CKC

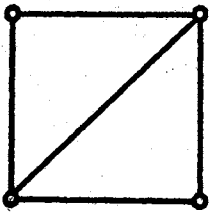
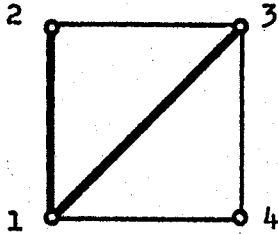
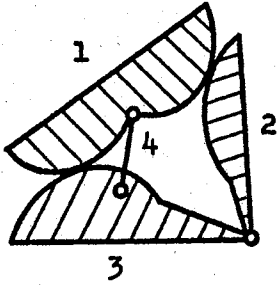
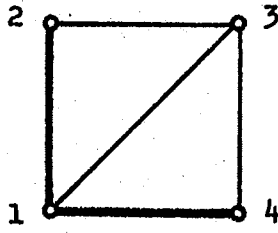
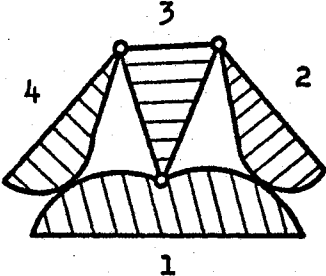
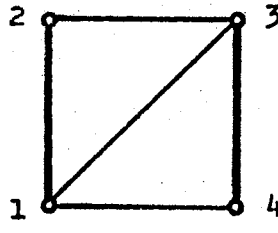
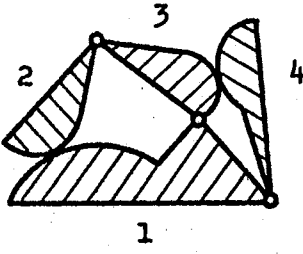
Linear Graph	Unequivalent Colored Graphs	Corresponding CKC
	<p>1.</p> 	<p>1a.</p> 
	<p>2.</p> 	<p>2a.</p> 
	<p>3.</p> 	<p>3a.</p> 

TABLE VIII

NON-LINEAR GRAPHS AND CKC DEVELOPED FROM PARENT 6 LINK CHAIN

Parent Kinematic Chain	Number of Cam Pairs (heavy edges)	Number of Fine Edges	Number of Vertices	Total Number of Edges	Number of Non-Linear Graphs	Non-Linear Graphs	Comment	Colored Graphs	Corresponding CKC
6 Links 7 Turning Joints	1	5	5	6	0				
	2	3	4	5	4	1.			
						2.	Rejected (Rule 1)		
						3.	Rejected (Rule 1)		
						4.	Rejected (Rule 1)		
3	1	3	4	1	1.				

and 7 edges are shown in Table IX. The number of the graphs is verified by the Polya's theory of counting shown in Table V of Example 2-8. All the corresponding CKC with 6 cam pairs are shown in Table X. Out of 15 colored graphs shown in Table IX, 5 are rejected. Graphs 7 (a), 8 (a) and 9 (a) are rejected because of Rule 1. Graphs 3 (a) and 5 (a) are rejected because of Rule 3. Therefore, there are only 10 CKC with 6 cam pairs developed from the parent 10 link kinematic chain.

The mobility equation for the planar kinematic chain (with one link fixed) having only rigid links and turning joints is

$$f = 3 (\ell - 1) - 2j \quad (6-3)$$

Substituting Eqs. (6-1) and (6-2) for  $\ell$  and  $j$  into Eq. (6-3), we obtain

$$\begin{aligned} f &= 3 (v + e_h - 1) - 2 (e_f + 2e_h) \\ &= 3 (v - 1) - 2e_f - e_h \end{aligned} \quad (6-4)$$

Eq. (6-4) is the same form as that of Gruebler's mobility criterion.  $v$  is corresponding to the number of links in the kinematic chain,  $e_f$  is corresponding to the number of kinematic pairs of class 1 in which the degree of freedom is 1 and  $e_h$  is corresponding to the number of kinematic pairs of class 2 in which the degree of freedom is 2.

Eq. (6-4) is the mobility equation for CKC. The equation is expressed in terms of vertices and edges of the colored graph.

For the CKC having degree of freedom  $f = 1$ , Eq. (6-4) becomes

$$3v - 2e_f - e_h - 4 = 0 \quad (6-5)$$

Eq. (6-5) is the equation in which the colored graph of CKC with  $f = 1$  should be satisfied.

TABLE IX

NON-LINEAR GRAPHS WITH 4 VERTICES AND 7 EDGES

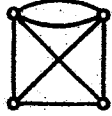
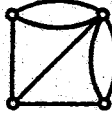

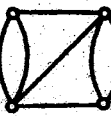
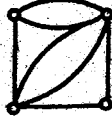
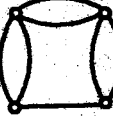
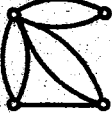
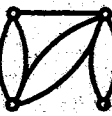
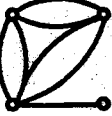
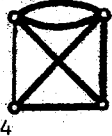














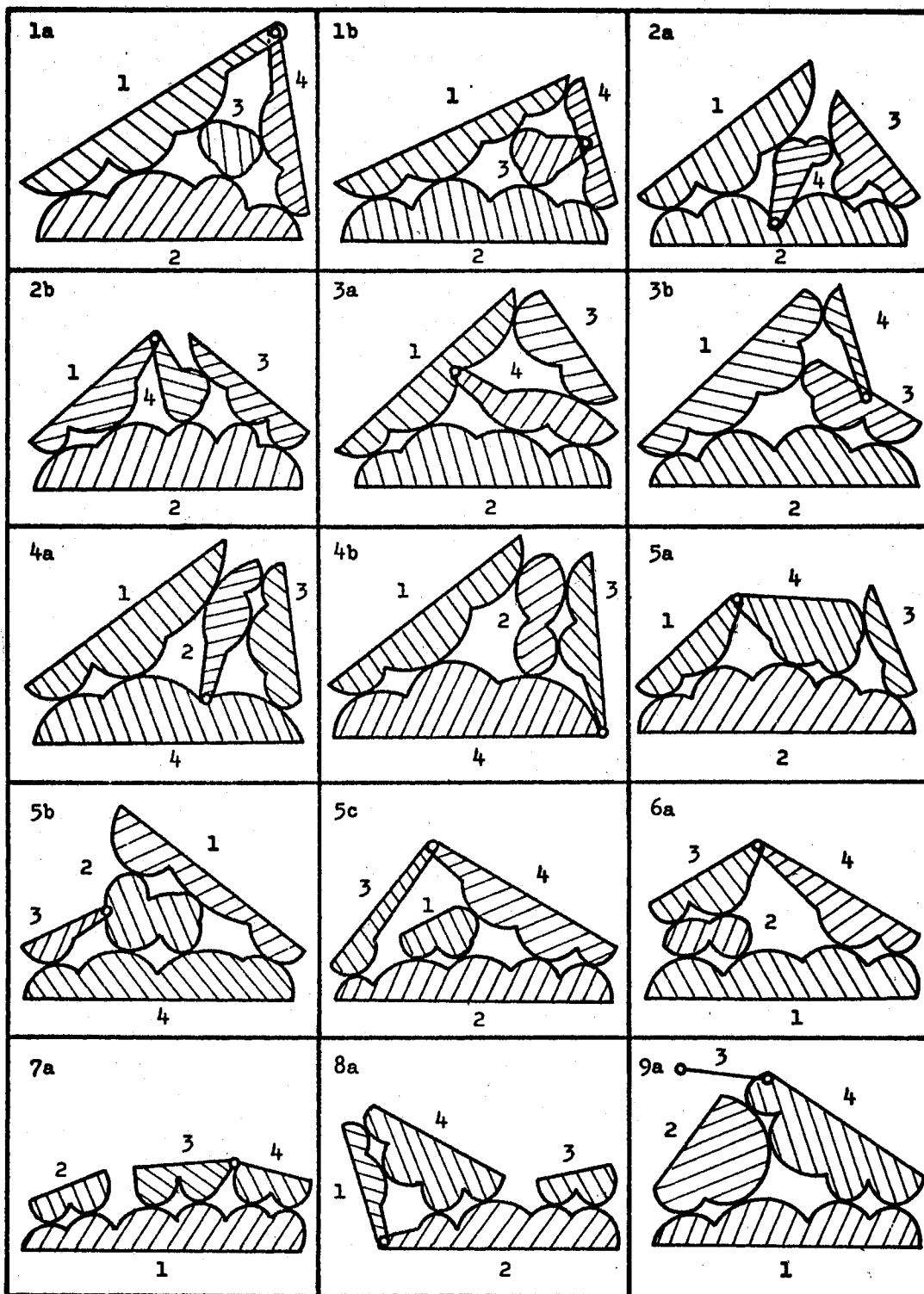
Number of Non-Linear Graphs with 4 Vertices and 7 Edges		1	2	3	4	5	6	7	8	9
										
Number of Non-Equivalent Colored Graphs	a									
	b									
	c									
Rejected				3 a		5 a		7 a	8 a	9 a
Comment			Against Rule 3			Against Rule 3		Against Rule 1	Against Rule 1	Against Rule 1

TABLE X

CKC WITH 6 CAM PAIRS OBTAINED FROM TABLE IX



It has been shown [35] that the maximum number of turning joints on a link of a closed parent kinematic chain with degree of freedom  $f$  is equal to the number of independent loops plus 1. Consequently, the maximum degree of vertex of a colored graph of closed CKC is also equal to the number of independent loops plus 1. Therefore,

$$d_{\max} = c + 1 \quad (6-6)$$

where

$d_{\max}$ : maximum degree of vertex of a colored graph.

$c$ : number of independent loops.

From the well-known Euler's formula, we know

$$c = j - \ell + 1 \quad (6-7)$$

Substituting Eq. (6-7) for  $c$  into Eq. (6-6), we have

$$d_{\max} = j - \ell + 2 \quad (6-8)$$

If Eq. (6-1) and (6-2) are substituted into Eq. (6-8), it becomes

$$\begin{aligned} d_{\max} &= e_f + 2e_h - (v + e_h) + 2 \\ &= (e_f + e_h) - v + 2 = e - v + 2 \end{aligned} \quad (6-9)$$

Since Eq. (6-9) which is expressed in terms of vertices and edges of a colored graph is equivalent to Eq. (6-8), it checks the correctness of the Eqs. (6-1) and (6-2).

If the variable  $j$  in Eqs. (6-3) and (6-8) is eliminated, we obtain

$$d_{\max} = \frac{\ell - f + 1}{2} \quad (6-10)$$

For the special case where kinematic chain has  $f = 1$ , then from Eq. (6-10), we have

$$d_{\max} = \frac{\ell}{2} \quad (6-11)$$

Eq. (6-10) establishes the upper bound of the degree of vertex in the colored graph of any kinematic chain with any kinematic elements derived from parent  $\ell$  link chain with degree of freedom  $f$ .

### Piston-Cylinder Kinematic Chains

Piston-cylinder kinematic chain (PKC) can be obtained by replacing two consecutive binary links in parent kinematic chain by piston-cylinder. Fig. 20 shows a parent 8 link kinematic chain and a PKC with two piston-cylinders. The latter is obtained by replacing binary links 4 and 8, 1 and 7 in parent kinematic chain by piston-cylinders 4 and 1 respectively. The graphical representations of both kinematic chains are shown in Fig. 21. Since a rigid link is represented by a fine vertex, the piston-cylinder which is kind of extendible link can be represented by another type of vertex, say heavy vertex as shown in Fig. 21 (b). Therefore, in the parent kinematic graph, two consecutive fine edges can be replaced by a fine edge with a heavy vertex at end. Since piston-cylinder is a two-terminal component which has two turning joints at end, the heavy vertex has to be placed at the end of fine edge where the degree of vertex is two.

Rule 6: The degree of heavy vertex in the colored graph of PKC should be equal to two.

The construction procedure of obtaining PKC from parent kinematic chain is similar to that of obtaining CKC from parent kinematic chain. In PKC, piston-cylinder is graphically represented by a heavy vertex, while in CKC, cam pair is by heavy edge. Therefore, the colored graph of PKC can be obtained directly from that of CKC.



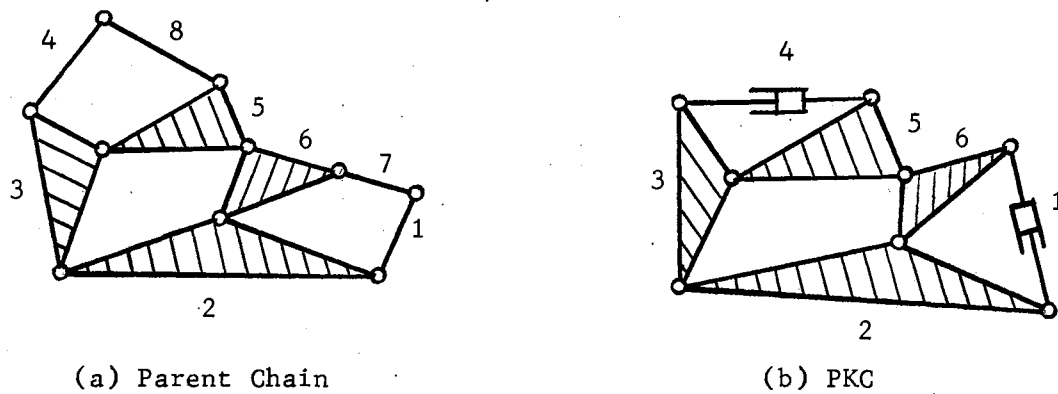


Figure 20. Parent Kinematic Chain and Piston-Cylinder Kinematic Chain (PKC)

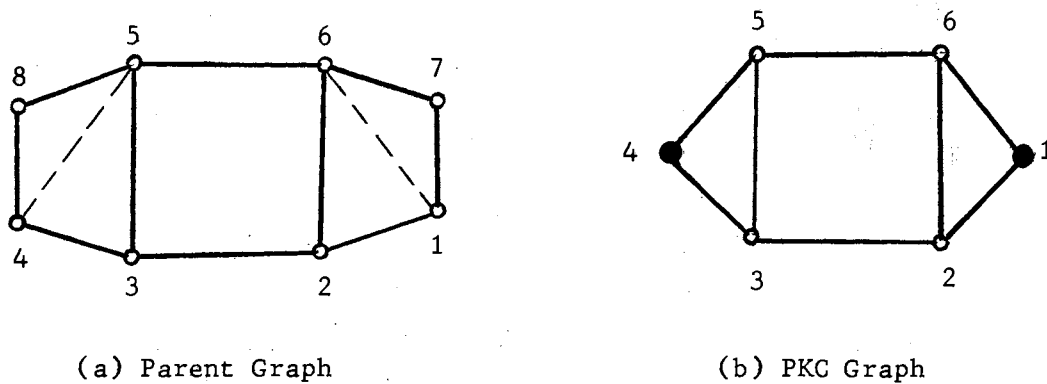


Figure 21. Graphical Representations of Parent Kinematic Chain and PKC

Fig. 22 shows that colored graph (c) of PKC is obtained by replacing heavy edges 12 and 34 in (a) by fine edges 12 and 34 with heavy vertices 1 and 4 at ends where the degrees of vertices are two's. Similarly, PKC graph can also be obtained from CKC colored graph shown in Fig. 22 (b).

From the ways of constructing PKC, two equations can be established as follows.

$$j = e_f + v_h \quad (6-12)$$

$$l = v_f + 2v_h \quad (6-13)$$

where

$j$ : number of turning joints in the parent kinematic chain.

$l$ : number of rigid links in the parent kinematic chain.

$e_f$ : number of fine edges in the colored graph.

$v_f$ : number of fine vertices in the colored graph.

$v_h$ : number of heavy vertices in the colored graph.

Substituting Eqs. (6-12) and (6-13) into Eq. (6-3), we have

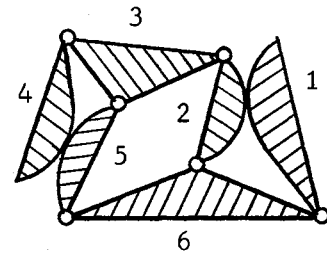
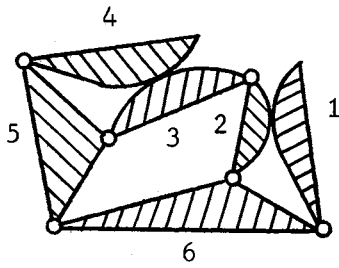
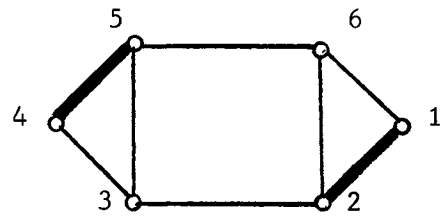
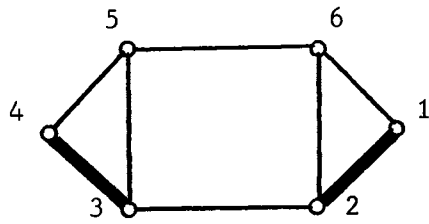
$$\begin{aligned} f &= 3(v_f + 2v_h - 1) - 2(e_f + v_h) \\ &= 3(v_f - 1) - 2(e_f - 2v_h) \end{aligned} \quad (6-14)$$

Eq. (6-14) is the mobility equation for PKC. The equation is expressed in terms of the vertices and edges of the colored graph.

For the PKC having degree of freedom  $f = 1$ , then Eq. (6-14) becomes

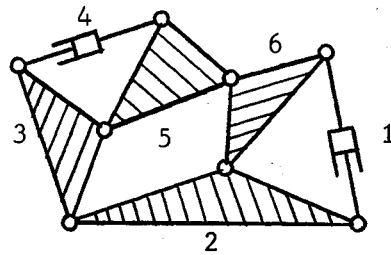
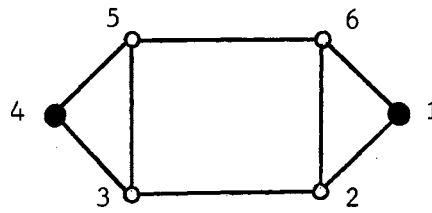
$$3v_f + 4v_h - 2e_f - 4 = 0 \quad (6-15)$$

Eq. (6-15) is the equation in which the colored graph of PKC with  $f = 1$  should be satisfied.



(a) CKC and Graph

(b) CKC and Graph



(c) PKC and Graph

Figure 22. Relationship Between Colored Graphs of CKC and PKC

The maximum degree of vertex,  $d_{\max}$ , of a colored graph of a closed PKC is derived from Eq. (6-8) and equal to

$$\begin{aligned} d_{\max} &= j - \mathcal{Q} + 2 = (e_f + v_h) - (v_f + 2v_h) + 2 \\ &= e_f - (v_f + v_h) + 2 = e - v + 2 \end{aligned} \quad (6-16)$$

### Prism Kinematic Chains

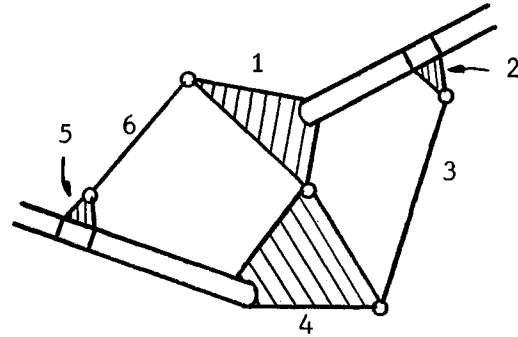
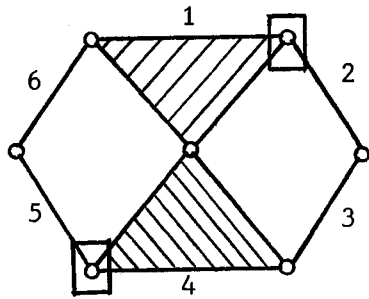
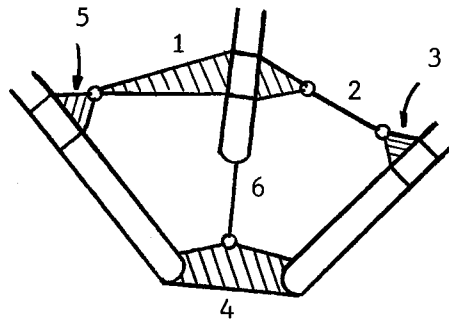
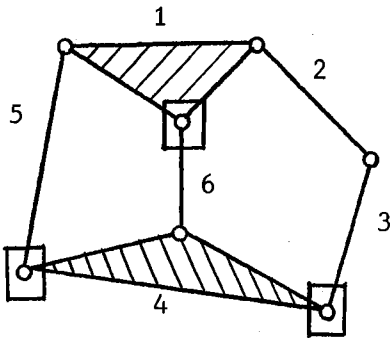
Prism kinematic chains ( $P_r$ KC) can be obtained by simply replacing revolute pairs by prism pairs. Fig. 23 shows two prism kinematic chains derived from Watt's and Stephenson's kinematic chains respectively.

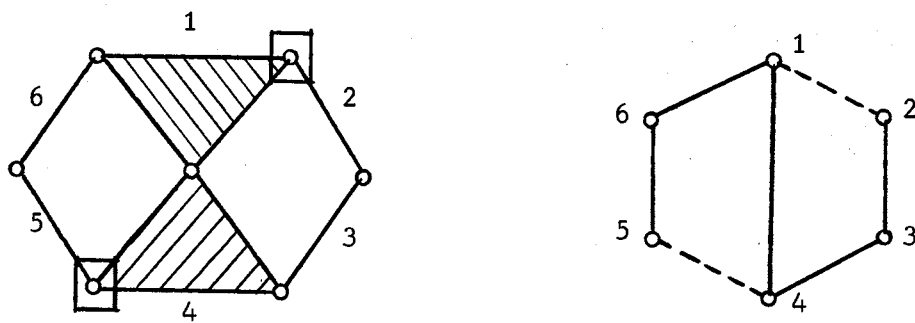
The graphical representation of a  $P_r$ KC is basically similar to that of a parent kinematic chain except that the prism pair which replaces the revolute pair in parent chain is represented by another type of fine edge, say fine dash edge. Therefore, the schematic drawings of  $P_r$ KC shown in Fig. 23 (a) and (b) can be graphically represented by kinematic graphs as shown in Fig. 24.

Since both revolute pair and prism pair belong to class 1 kinematic pair with one degree of freedom, the number of fine edges and fine dash edges should be counted by the same designation  $e_f$ .

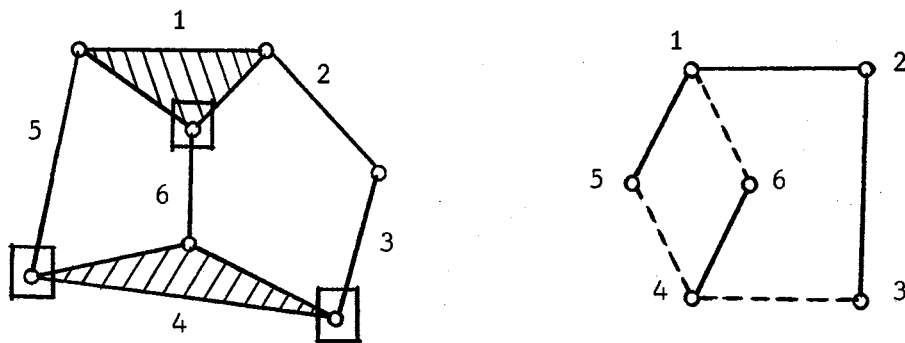
In constructing  $P_r$ KC, the revolute pair in parent kinematic chain is replaced by prism pair. The replacement of rotational motion of revolute pair by translational motion of prism pair may change the constrained motion in  $P_r$ KC. Therefore, the following three rules should be observed in order that  $P_r$ KC has a constrained motion.

Rule 7: No link of the chain may contain only prism pairs whose directions of motion are parallel to each other.

(a) Watt's Chain and  $P_r KC$ (b) Stephenson's Chain and  $P_r KC$ Figure 23. Prism Kinematic Chains ( $P_r KC$ )



(a)  $P_r$ KC and Its Graph



(b)  $P_r$ KC and Its Graph

Figure 24. Graphical Representation of  $P_r$ KC

Fig. 25 illustrates the restriction by Rule 7. The  $P_r$ KC is derived from parent four link chain. Link 2 has 2 prism pairs whose directions of motion are parallel to each other. Therefore, link 2 can have motion independent of the motions of links 1, 3 and 4. Consequently, there is no constrained motion in the chain.

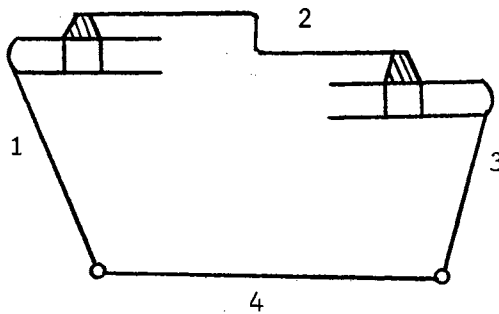


Figure 25.  $P_r$ KC against Rule 7

Rule 8: Two consecutive binary links of the chain can not have only prism pairs.

Fig. 26 serves to illustrate the restriction by Rule 8. Links 3 and 4 are binary links connected to each other and have only prism pairs. Without moving links 1, 2, 5 and 6, links 3 and 4 can still be moved to positions 3' and 4'. Therefore, the chain does not have constrained motion.

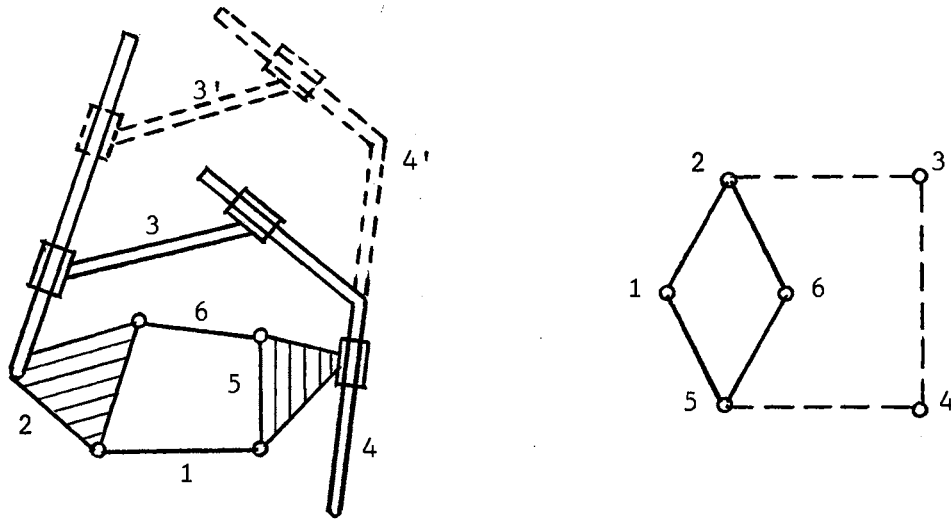


Figure 26.  $P_r$ KC against Rule 8

Rule 9: Minimum number of revolute pairs in a kinematic loop of the chain is two. (or maximum number of prism pairs in a kinematic loop of the chain is  $n-2$ , where  $n$  is number of links in that loop.)

Fig. 27 illustrates the restriction by Rule 9. In the upper kinematic loop, there are four links 2, 3, 4 and 5, three prism pairs 25, 23 and 45. The prism pair 25 constrains the links 2 and 5 to make constant angle to each other. Due to the presence of prism pairs 23 and 45, links 3 and 4 also form a constant angle to each other. Therefore, despite of revolute pair 34, there is no relative motion between links 3 and 4. Thus, links 3 and 4 form a single rigid link, and the chain does not have constrained motion.



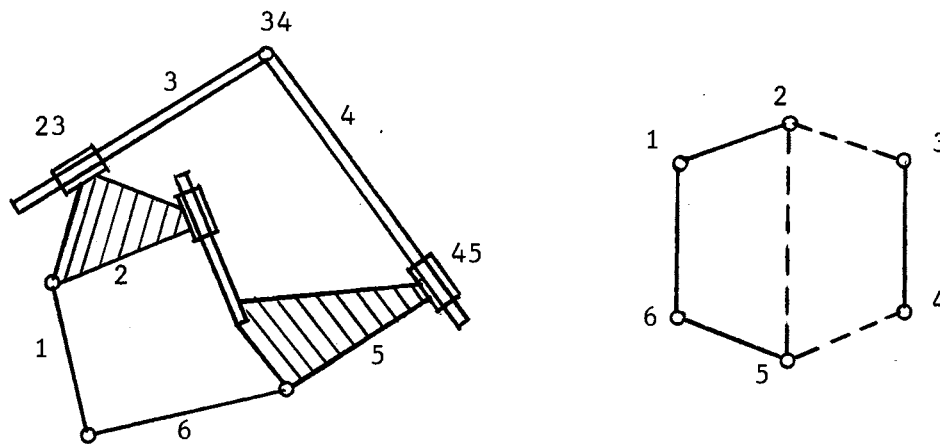


Figure 27.  $P_r$  KC against Rule 9

The maximum number of prism pairs in a kinematic chain is a function of kinematic loops. A 4-link chain with one kinematic loop can have maximum of two prism pairs; a 6-link chain with two kinematic loops can have maximum of four prism pairs and an 8-link chain with three kinematic loops can have maximum of six prism pairs, therefore, by inductive process, we obtain

$$P_{\max} = 2c \quad (6-17)$$

where

$P_{\max}$ : maximum number of prism pairs in a kinematic chain.

$c$ : number of kinematic loops in the kinematic chain.

Substituting  $c$  from Eq. (6-7) into Eq. (6-17), we obtain

$$P_{\max} = 2(j - l + 1) \quad (6-18)$$

If the variable  $j$  in Eqs. (6-3) and (6-18) is eliminated, we get

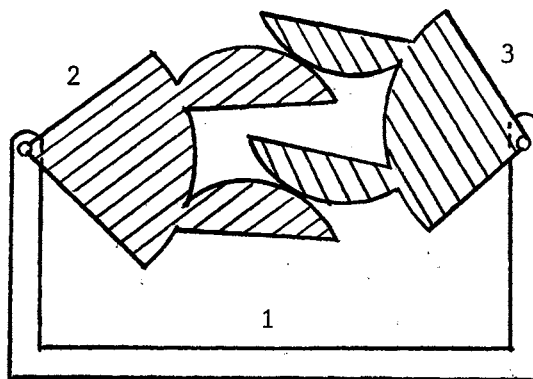
$$P_{\max} = l - f - 1 \quad (6-19)$$

For the special case where kinematic chain has  $f = 1$ , Eq. (6-19) then becomes

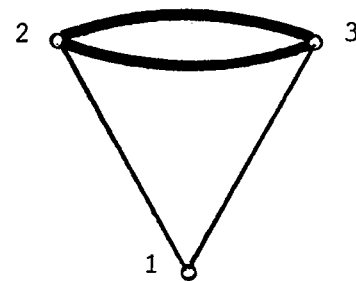
$$P_{\max} = l - 2 \quad (6-20)$$

### Gear Kinematic Chains

A gear kinematic chain (GKC) is a special form of a cam kinematic chain (CKC). The gears considered here are spur gears. Fig. 28 shows a GKC and its colored graph.



(a) GKC with  $f = 0$



(b) Colored Graph

Figure 28. A GKC and Its Colored Graph

From Eqs. (6-1), (6-2) and Fig. 28 (b), we have

$$j = e_f + 2e_h = 2 + 2 \times 2 = 6$$

$$l = v + e_h = 3 + 2 = 5$$

Substituting the values of  $l$  and  $j$  into Eq. (6-3), we have

$$f = 3 (l - 1) - 2j = 3 (5 - 1) - 2 \times 6 = 0$$

Therefore, the CKC shown in Fig. 23 (a) has no mobility. But, if we impose a geometric condition on the cam surfaces such that the common normals through the contact points intersect on a line through pivots (or turning joints) as shown in Fig. 29, then the CKC has constrained motion. It has the constant angular velocity ratio between bodies 2 and 3. Therefore, the CKC becomes a GKC.

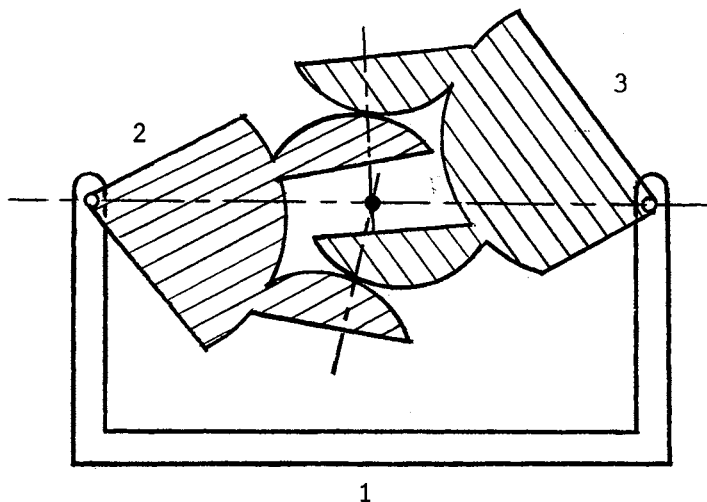


Figure 29. A CKC Becomes A Gear Kinematic Chain (GKC)

The schematic and graphical representations of the GKC are shown in Fig. 30 (a) and (b) respectively. The graphical representation of GKC is somehow similar to that of CKC. The gear joint is represented by another type of heavy edge shown in Fig. 30 (b). Vertex 1 in Fig. 30 (b) is called a transfer vertex [67] which is equivalent to the gear carrier 1 in GKC. For a special type of GKC whose 2-colored graphs contain trees<sup>3</sup>, the reader is referred to the references [51, 52, 67]. In this special type of GKC, every gear has the motion of complete rotation.

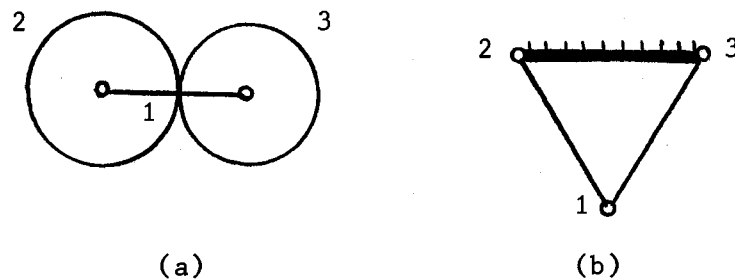


Figure 30. Schematic and Graphical Representation of GKC

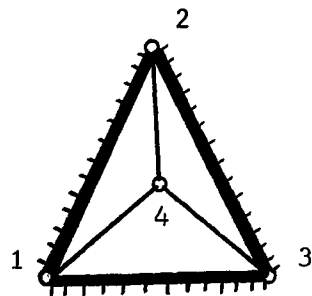
---

<sup>3</sup>A tree in a 2-colored graph is the set of fine edges. The remainder of the heavy edges constitute the chord set.

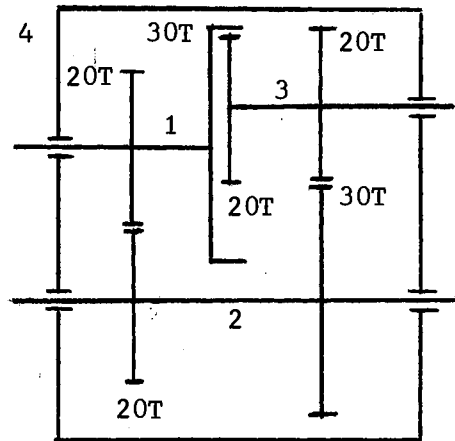
Some colored graphs of GKC must be rejected because of Rule 10 and Rule 11.

Rule 10: A colored graph of GKC whose subgraph is a triangle with three heavy edges is rejected. In general, a GKC having the kind of colored graph described in Rule 10 has no mobility.

Under certain geometric conditions, the GKC whose colored graph violates Rule 10 may have a constrained motion. One paradoxical GKC shown by Freudenstein and Yang<sup>4</sup> is a typical example (Fig. 31). There are 4 vertices, 3 fine edges and 3 heavy edges in the 2-colored graph shown in Fig. 31 (a).



(a) Colored Graph



(b) Paradoxical GKC

Figure 31. A Colored Graph and Its Paradoxical GKC

<sup>4</sup>Given in the lecture of NSF advanced training workshop in mechanisms in Oklahoma State University, Aug., 1971.

The geometric constraint imposed on the paradoxical GKC is

$$N_{12} N_{23} N_{31} = 1 \quad (6-21)$$

where

$N_{ij}$ : the gear ratio of gear  $i$  to gear  $j$ .

A typical GKC satisfying the constraint is shown in Fig. 31 (b) in which  $N_{12} = -1$ ,  $N_{21} = -3/2$ ,  $N_{31} = 2/3$  and

$$N_{12} N_{23} N_{31} = (-1) (-3/2) (2/3) = 1$$

Vertex 4 in Fig. 31 (a) is the transfer vertex and is equivalent to the gear box shown in Fig. 31 (b).

Rule 11: Any gear pair should have a gear carrier associated with it.

In the case of GKC whose colored graph contains a tree, the gear carriers can be found by the determination of transfer vertices [67].

The mobility equations and maximum degree of vertex equation for the colored graph of GKC are the same as those Eqs. (6-4), (6-5) and (6-9) for the colored graph of CKC.

#### Spring Kinematic Chains

Spring kinematic chain (SKC) can be obtained by replacing two consecutive binary links in a parent kinematic chain by a spring. Fig. 32 shows a parent 4 link chain, SKC and its corresponding colored graph. The spring element is represented graphically by another type of heavy vertex shown in Fig. 32 (c).

From the point of structural synthesis of kinematic chains, SKC has the same properties as PKC does. The rules and equations for PKC are also valid for SKC.

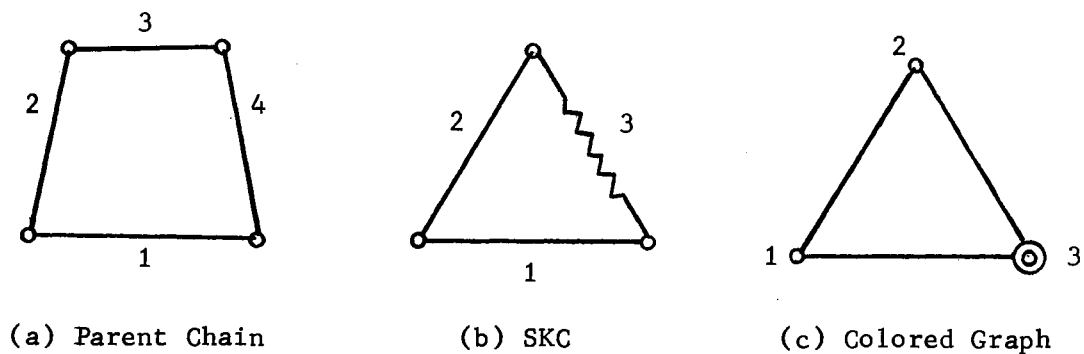
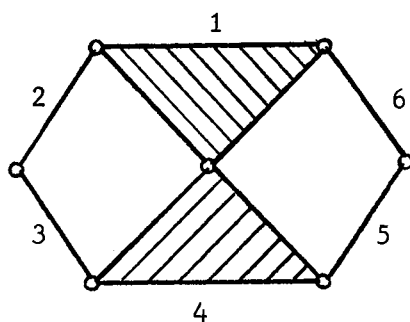


Figure 32. Parent Four-Link Chain, SKC and Its Colored Graph

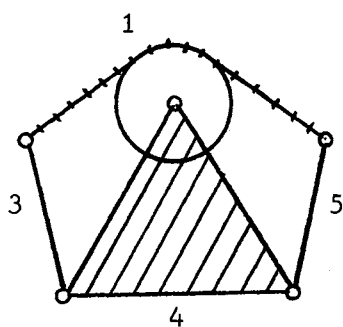
### Belt-Pulley Kinematic Chains

A belt-pulley kinematic chain (BKC) can be obtained by replacing a ternary link and its associated two binary links in a parent kinematic chain. The ternary link is replaced by a pulley and each of the binary links is replaced by a section of belt rolling on the pulley.

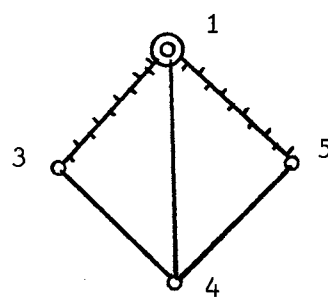
The BKC shown in Fig. 33 (b) is obtained by replacing ternary link 1 and its associated two binary links 2, 6 in the parent chain shown in Fig. 33 (a) by a belt-pulley. The colored graph of BKC shown in Fig. 33 (c) is obtained by representing graphically the pulley and belt with a double vertex and a type of heavy edge respectively.



(a) Parent Chain



(b) BKC



(c) Colored Graph

Figure 33. Parent Six-Link Chain, BKC  
and Its Colored Graph



Since the pulley should have a belt around it and a turning joint acting as the axis of the pulley, we obtain Rule 12.

Rule 12: The double-vertex of the colored graph of BKC should have two heavy edges and at least one fine edge incident with it.

Two equations are proposed to relate the parent kinematic chain to BKC,

$$l = v_f + v_d + e_h \quad (6-22)$$

$$j = e_f + 2e_h \quad (6-23)$$

Where  $l$ : number of rigid links in the parent kinematic chain.  
 $j$ : number of turning joints in the parent kinematic chain.  
 $v_f$ : number of fine vertices in the colored graph.  
 $v_d$ : number of double-vertices in the colored graph.  
 $e_f$ : number of fine edges in the colored graph.  
 $e_h$ : number of heavy edges in the colored graph.

Substituting Eqs. (6-22) and (6-23) into Eq. (6-3), we have

$$\begin{aligned} f &= 3(v_f + v_d + e_h - 1) - 2(e_f + 2e_h) \\ &= 3(v_f + v_d - 1) - 2e_f - e_h \end{aligned} \quad (6-24)$$

Eq. (6-24) is also in the same form as that of Gruebler's mobility criterion.  $(v_f + v_d)$  is corresponding to the number of links in the parent kinematic chain,  $e_f$  is corresponding to the number of kinematic pairs of class 1 in which the degree of freedom is 1 and  $e_h$  is corresponding to the number of kinematic pairs of class 2 in which the degree of freedom is 2.

Eq. (6-24) is the mobility equation for BKC. The equation is expressed in terms of vertices and edges of the colored graph. It should be noted that Eq. (6-24) is similar to Eq. (6-4) for CKC in

which  $(v_f + v_d)$  in Eq. (6-24) is equivalent to  $v$  in Eq. (6-4). For the BKC having degree of freedom  $f = 1$ , then Eq. (6-24) becomes

$$3(v_f + v_d) - 2e_f - e_h - 4 = 0 \quad (6-25)$$

Eq. (6-25) is the equation in which the colored graph of BKC with  $f = 1$  should be satisfied.

The maximum degree of vertex,  $d_{\max}$ , of a colored graph of a closed BKC is also equal to  $e - v + 2$  which can be derived by substituting Eqs. (6-22) and (6-23) into Eq. (6-8).

$$\begin{aligned} d_{\max} &= j - l + 2 \\ &= (e_f + 2e_h) - (v_f + v_d + e_h) + 2 \\ &= (e_f + e_h) - (v_f + v_d) + 2 \\ &= e - v + 2 \end{aligned} \quad (6-26)$$

#### Kinematic Chains with Combination of Different Kinematic Elements

The different kinematic chains discussed so far are CKC (with cam pairs), P<sub>r</sub>KC (with prism pairs), GKC (with gears), PKC (with piston-cylinders), SKC (with springs) and BKC (with belt-pulleys). The general formula and mobility equation of the kinematic chains with the combination of the different kinematic elements are to be discussed in this section.

Two general equations which relate the parent kinematic chain to the general colored graph are described below:

$$l = v_f + e_h + v_d + 2v_h \quad (6-27)$$

$$j = e_f + 2e_h + v_h \quad (6-28)$$

where

- $l$ : number of rigid links in the parent kinematic chain.  
 $j$ : number of turning joints in the parent kinematic chain.  
 $v_f$ : number of fine vertices in the colored graph (for rigid links).  
 $v_h$ : number of heavy vertices in the colored graph (for piston-cylinders and springs)  
 $v_d$ : number of double-vertices (for pulleys).  
 $e_f$ : number of fine edges (for revolute and prism pairs)  
 $e_h$ : number of heavy edges (for cam pairs, gears, belts).

Substituting the Eqs. (6-27) and (6-28) into Eq. (6-3), it becomes

$$\begin{aligned} f &= 3 (v_f + e_h + v_d + 2v_h - 1) - 2 (e_f + 2e_h + v_h) \\ &= 3 (v_f + v_d - 1) + 4v_h - 2e_f - e_h \end{aligned} \quad (6-29)$$

Eq. (6-29) is the general mobility equation for the kinematic chains with a combination of different kinematic elements. The equation is expressed in terms of the vertices and edges of the general colored graph.

For the kinematic chain having degree of freedom  $f = 1$ , Eq. (6-29) becomes

$$3 (v_f + v_d) + 4 (v_h - 1) - 2e_f - e_h = 0 \quad (6-30)$$

Eq. (6-30) is the equation in which the colored graph of kinematic chain should be satisfied.

The maximum degree of vertex,  $d_{\max}$ , of a general colored graph of a closed kinematic chain with a combination of different kinematic elements is also equal to  $e - v + 2$  which can be derived by substituting Eqs. (6-27) and (6-28) into Eq. (6-8).

$$\begin{aligned}
 d_{\max} &= j - \ell + 2 \\
 &= (e_f + 2e_h + v_h) - (v_f + e_h + v_d + 2v_h) + 2 \\
 &= (e_f + e_h) - (v_f + v_h + v_d) + 2 = e - v + 2 \quad (6-31)
 \end{aligned}$$

As an example, a colored graph and its corresponding kinematic chain are shown in Fig. 34.

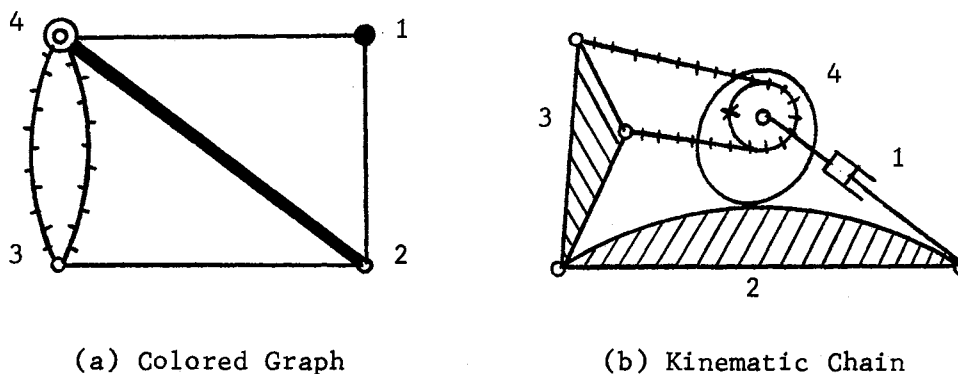


Figure 34. A Colored Graph and Its Corresponding Kinematic Chain

From the colored graph, we have

$$v_f = 2 \quad e_f = 3$$

$$v_h = 1 \quad e_h = 3$$

$$v_d = 1$$

Substituting these values into Eqs. (6-27) and (6-28), we have

$$l = 2 + 3 + 1 + 2 \times 1 = 8$$

$$j = 3 + 2 \times 3 + 1 = 10$$

Therefore, we know the colored graph is developed from a parent 8 link, 10 joint kinematic chain. When one of the links of the kinematic chain shown in Fig. 34 (b) is fixed, it has constrained motion and can be verified from Eq. (6-29).

$$\begin{aligned} f &= 3(2 + 1 - 1) + 4 \times 1 - 2 \times 3 - 3 \\ &= 6 + 4 - 6 - 3 = 1 \end{aligned}$$

The maximum degree of vertex in the colored graph can be found from Eq. (6-31).

$$d_{\max} = e - v + 2 = 6 - 4 + 2 = 4$$

That is,  $d_{\max}$  is the degree of vertex 4 of the colored graph shown in Fig. 34 (a).

## CHAPTER VII

### COLORED GRAPHS AND THEIR CORRESPONDING KINEMATIC CHAINS DEVELOPED FROM PARENT EIGHT-LINK CHAIN

In this chapter, all the colored graphs and their corresponding kinematic chains developed from parent 8 link, 10 joint chains are presented in three tables. Due to the large number of prism kinematic chains ( $P_r KC$ ), the listing of  $P_r KC$  is separately shown in Appendix C, and the combination of prism pairs with other kinematic elements are not considered. Table XI shows the kinematic chains with different number of kinematic elements. Since spring kinematic chain (SKC) is structurally similar to the piston-cylinder kinematic chain (PKC), kinematic chains having springs are not shown in the tables, except in the case where both springs and piston-cylinders appear in the kinematic chains.

The maximum number of different kinematic elements included in the kinematic chains developed from parent 8 link chains is three. Therefore, only three tables are prepared for kinematic chains having one, two and three different kinematic elements. The total number of colored graphs shown in three tables is 652. The number of prism kinematic chains with 1 up to 6 prism pairs is 3309 (Appendix C).

TABLE XI

KINEMATIC CHAINS WITH DIFFERENT NUMBER  
OF KINEMATIC ELEMENTS

Kinematic Chains with									
One I. Kinematic Element		Two II. Kinematic Elements		Three III. Kinematic Elements		Four IV. Kinematic Elements		Five V. Kinematic Elements	
I-1	C( <sup>Gam</sup> <sub>pair</sub> )	II-1	C-P	III-1	C-P-G	IV-1	C-P-G-S	V-1	C-P-G-S-B
I-2	P( <sup>Piston-</sup> <sub>cylinder</sub> )	II-2	C-G	III-2	C-P-S	IV-2	C-P-G-B		
I-3	G(Gear)	II-3	C-S	III-3	C-P-B	IV-3	P-G-S-B		
I-4	S(Spring)	II-4	C-B	III-4	P-G-S	IV-4	C-P-S-B		
I-5	B( <sup>Belt-</sup> <sub>pulley</sub> )	II-5	P-G	III-5	P-G-B	IV-5	C-G-S-B		
		II-6	P-S	III-6	G-S-B				
		II-7	P-B	III-7	C-G-S				
		II-8	G-S	III-8	C-G-B				
		II-9	G-B	III-9	C-S-B				
		II-10	S-B	III-10	P-S-B				

Colored Graphs and Kinematic Chains  
with One Kinematic Element

The colored graphs and their corresponding kinematic chains with one kinematic element are shown in Table XII.

The numbers of kinematic chains are shown below:

Kinematic Chain	Number
CKC	143
PKC	20
GKC	65
BKC	50
<hr/>	
Total:	278

Colored Graphs and Kinematic Chains  
with Two Kinematic Elements

The colored graphs and their corresponding kinematic chains with two kinematic elements are shown in Table XIII.

The numbers of kinematic chains are shown on next page.



Kinematic Chain	Number
C-P KC	49
C-G KC	112
C-B KC	83
P-G KC	34
P-S KC	9
P-B KC	17
G-B KC	31
<hr/>	
Total:	335

Colored Graphs and Kinematic Chains  
with Three Kinematic Elements

The colored graphs and their corresponding kinematic chains with three kinematic elements are shown in Table XIV.

The number of kinematic chains are shown below:

Kinematic Chain	Number
C-P-G KC	18
C-P-S KC	6
C-P-B KC	7
P-G-S KC	5
C-G-B KC	3
<hr/>	
Total:	39

TABLE XII

COLORED GRAPHS AND KINEMATIC CHAINS  
WITH ONE KINEMATIC ELEMENT

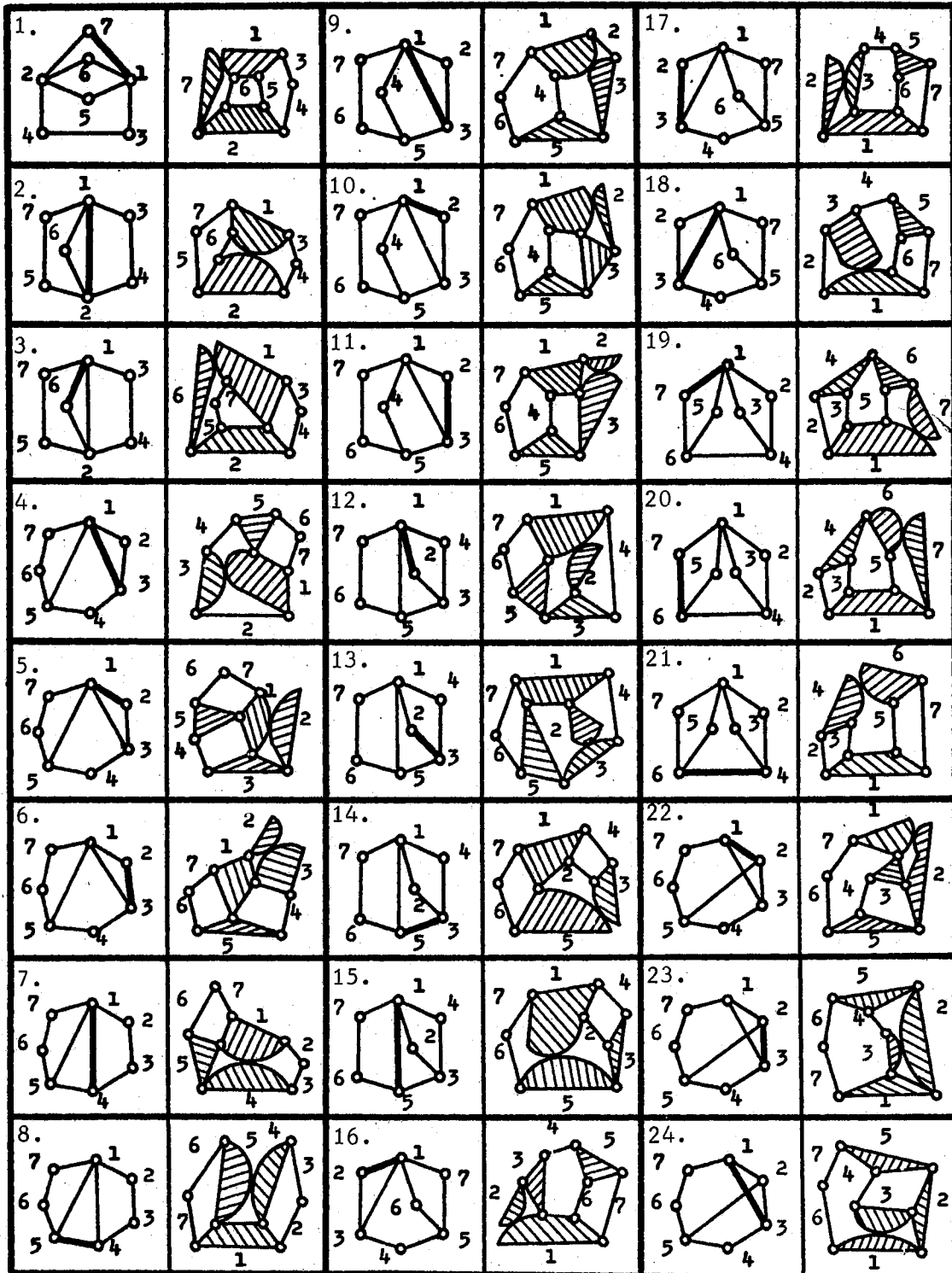


TABLE XII (CONTINUED)

25. 		33. 		41. 	
26. 		34. 		42. 	
27. 		35. 		43. 	
28. 		36. 		44. 	
29. 		37. 		45. 	
30. 		38. 		46. 	
31. 		39. 		47. 	
32. 		40. 		48. 	

TABLE XII (CONTINUED)

49.		57.		65.	
50.		58.		66.	
51.		59.		67.	
52.		60.		68.	
53.		61.		69.	
54.		62.		70.	
55.		63.			
56.		64.			

TABLE XII (CONTINUED)

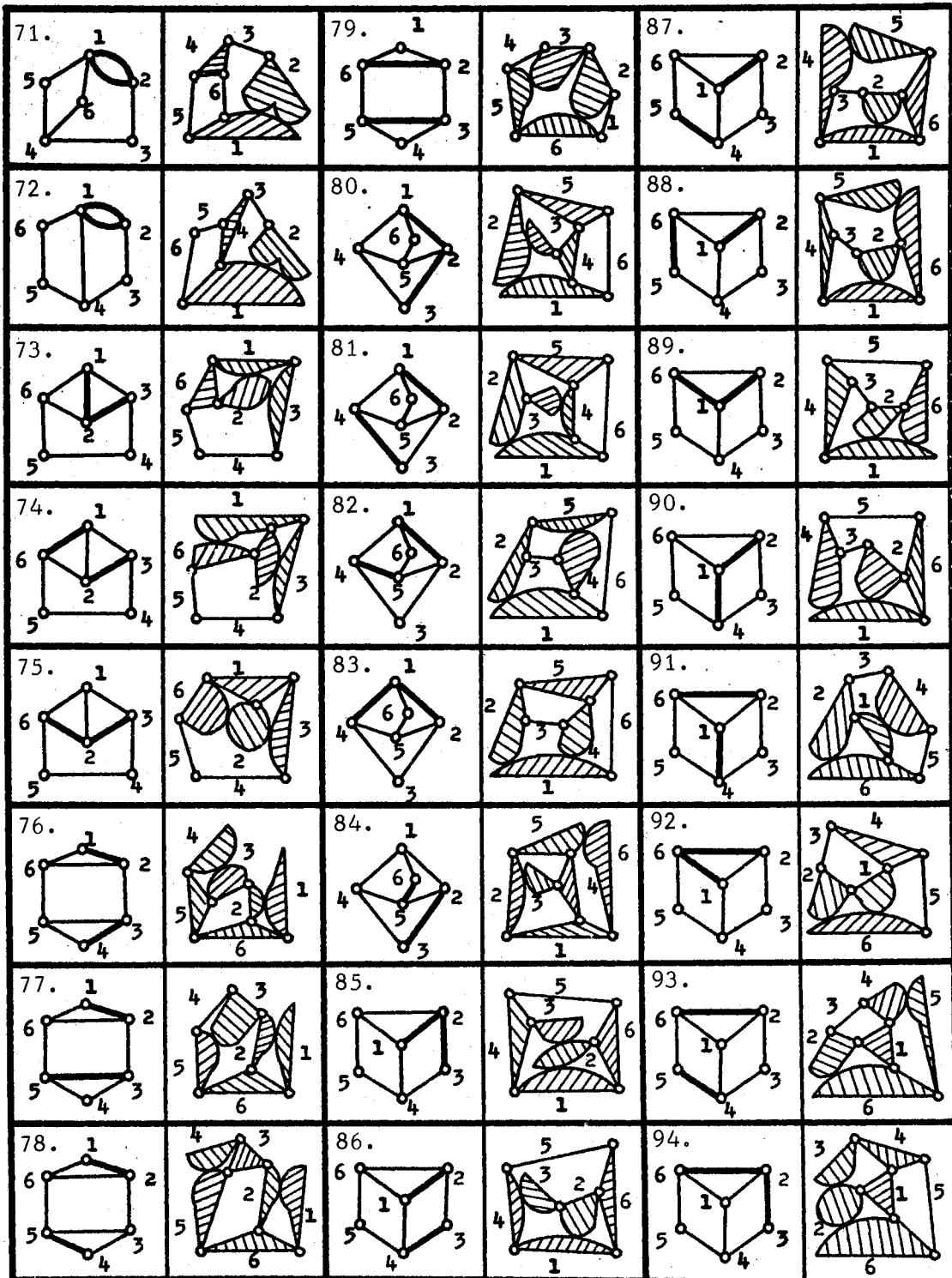


TABLE XII (CONTINUED)

95. 		103. 		111. 	
96. 		104. 		112. 	
97. 		105. 		113. 	
98. 		106. 		114. 	
99. 		107. 		115. 	
100. 		108. 		116. 	
101. 		109. 		117. 	
102. 		110. 		118. 	

TABLE XII (CONTINUED)

119. 		127. 		135. 	
120. 		128. 		136. 	
121. 		129. 		137. 	
122. 		130. 		138. 	
123. 		131. 		139. 	
124. 		132. 		140. 	
125. 		133. 		141. 	
126. 		134. 		142. 	

TABLE XII (CONTINUED)

143.		151.		159.	
144.		152.		160.	
145.		153.		161.	
146.		154.		162.	
147.		155.		163.	
148.		156.		164.	
149.		157.		165.	
150.		158.		166.	



TABLE XII (CONTINUED)

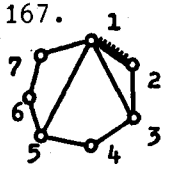
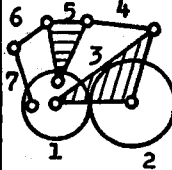
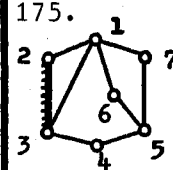
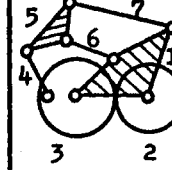
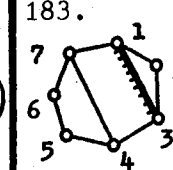
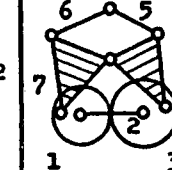
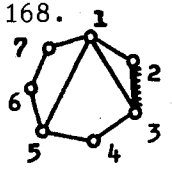
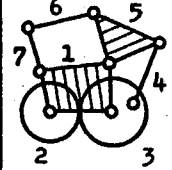
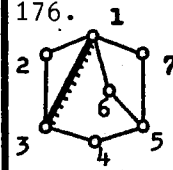
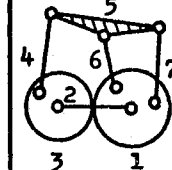
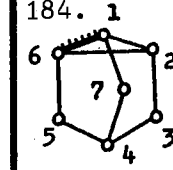
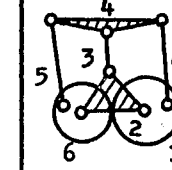
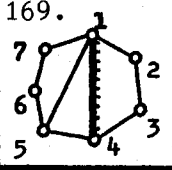
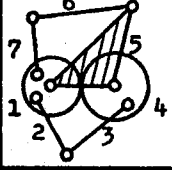
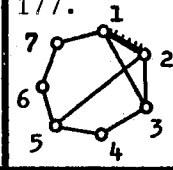
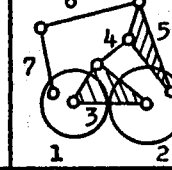
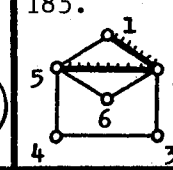
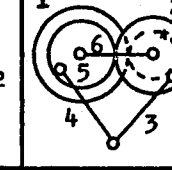
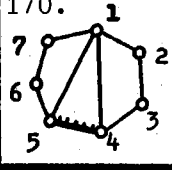
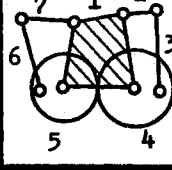
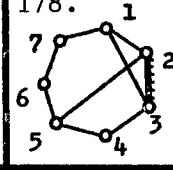
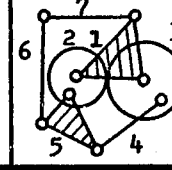
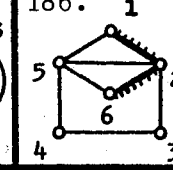
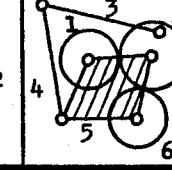
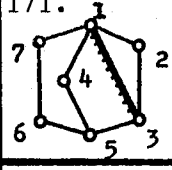
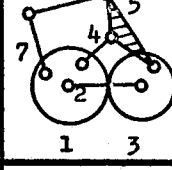
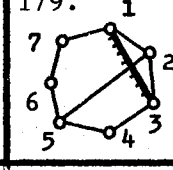
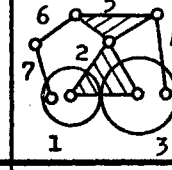
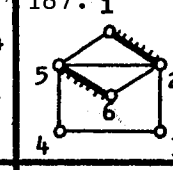
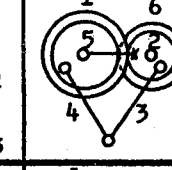
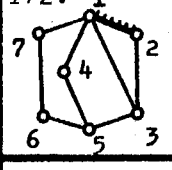
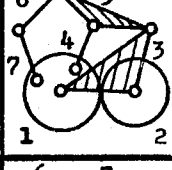
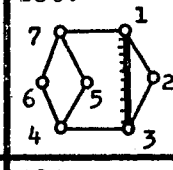
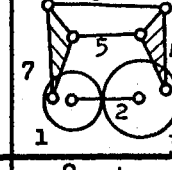
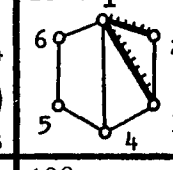
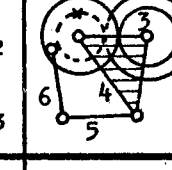
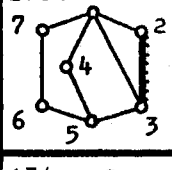
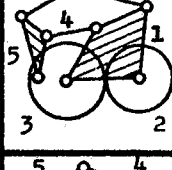
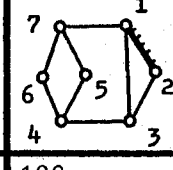
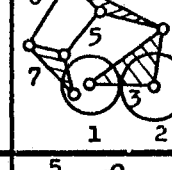
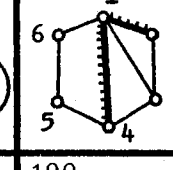
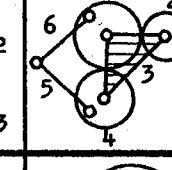
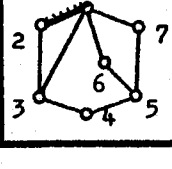
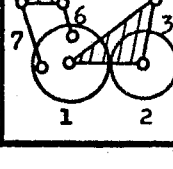
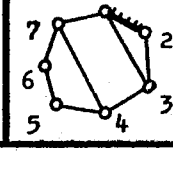
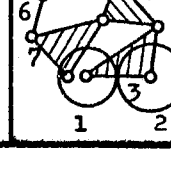
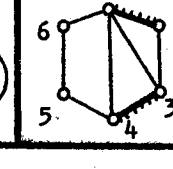
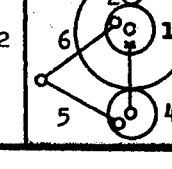
167. 		175. 		183. 	
168. 		176. 		184. 	
169. 		177. 		185. 	
170. 		178. 		186. 	
171. 		179. 		187. 	
172. 		180. 		188. 	
173. 		181. 		189. 	
174. 		182. 		190. 	

TABLE XII (CONTINUED)

191.		199.		207.	
192.		200.		208.	
193.		201.		209.	
194.		202.		210.	
195.		203.		211.	
196.		204.		212.	
197.		205.		213.	
198.		206.		214.	

TABLE XII (CONTINUED)

215.		223.		231.	
216.		224.		232.	
217.		225.		233.	
218.		226.		234.	
219.		227.		235.	
220.		228.		236.	
221.		229.		237.	
222.		230.		238.	

TABLE XII (CONTINUED)

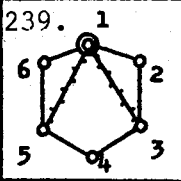
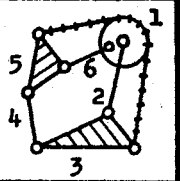
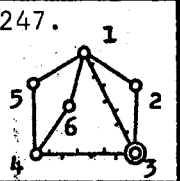
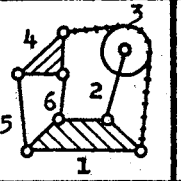
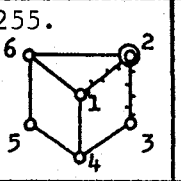
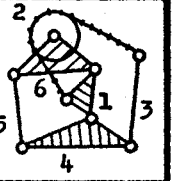
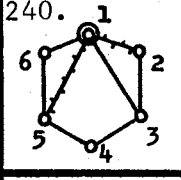
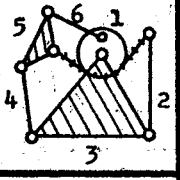
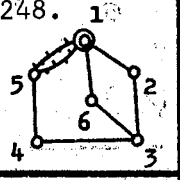
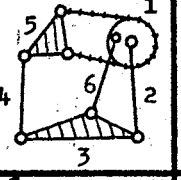
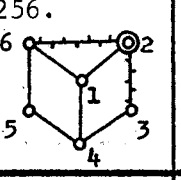
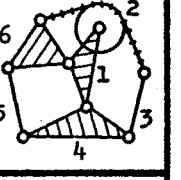
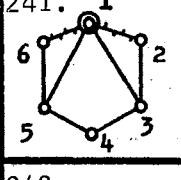
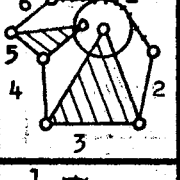
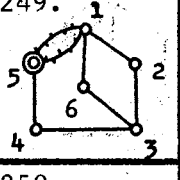
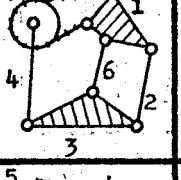
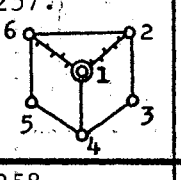
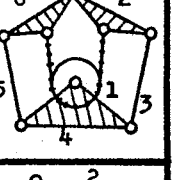
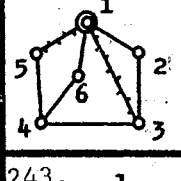
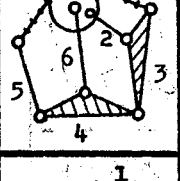
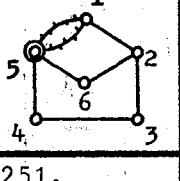
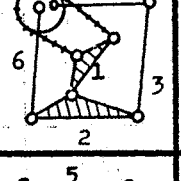
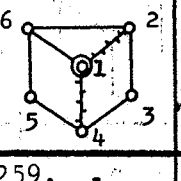
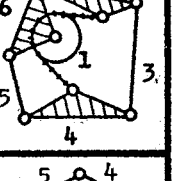
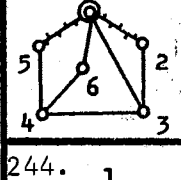
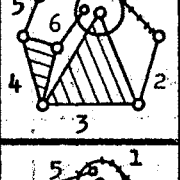
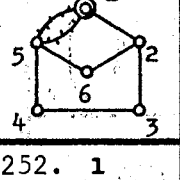
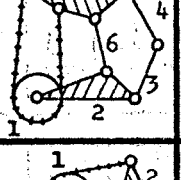
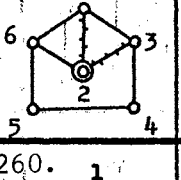
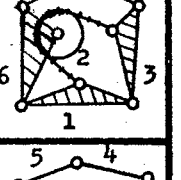
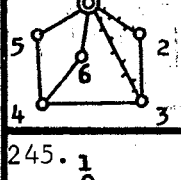
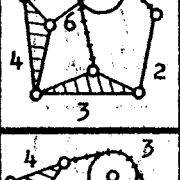
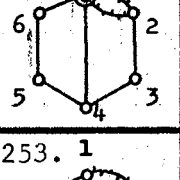
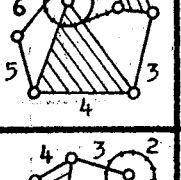
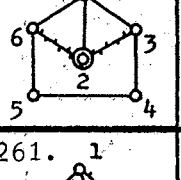
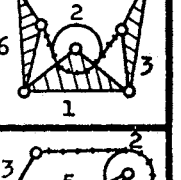
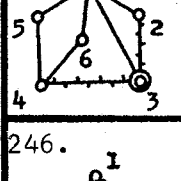
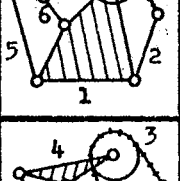
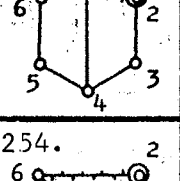
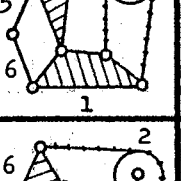
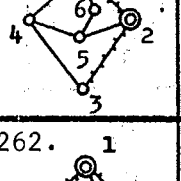
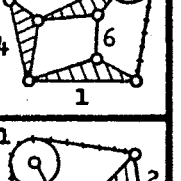
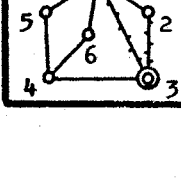
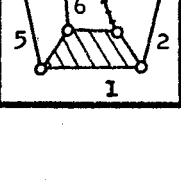
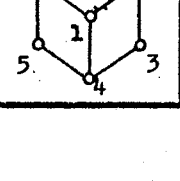
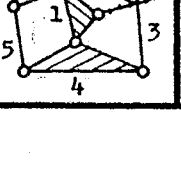
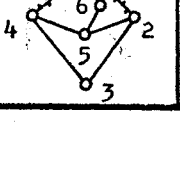
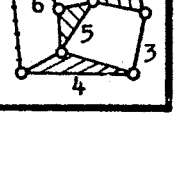
239. 		247. 		255. 	
240. 		248. 		256. 	
241. 		249. 		257. 	
242. 		250. 		258. 	
243. 		251. 		259. 	
244. 		252. 		260. 	
245. 		253. 		261. 	
246. 		254. 		262. 	

TABLE XII (CONTINUED)

263. 		271. 			
264. 		272. 			
265. 		273. 			
266. 		274. 			
267. 		275. 			
268. 		276. 			
269. 		277. 			
270. 		278. 			



TABLE XIII (CONTINUED)

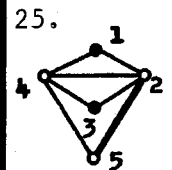
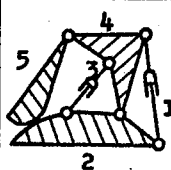
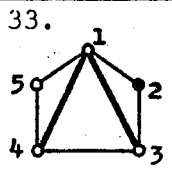
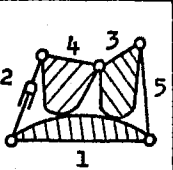
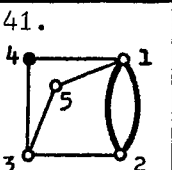
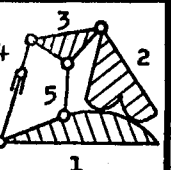
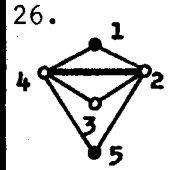
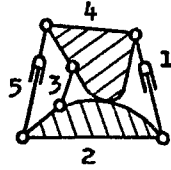
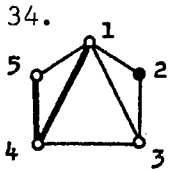
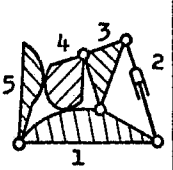
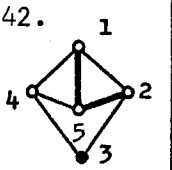
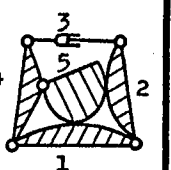
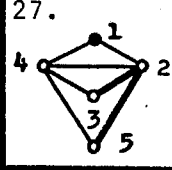
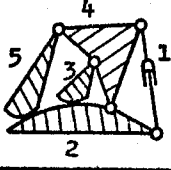
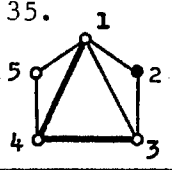
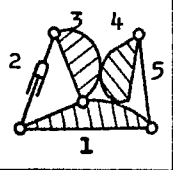
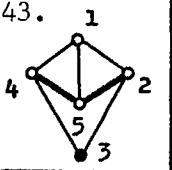
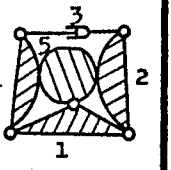
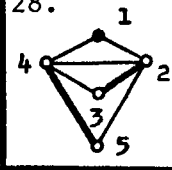
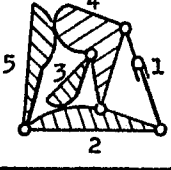
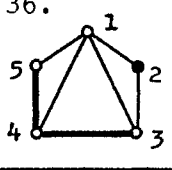
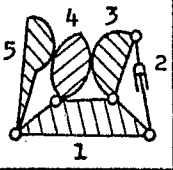
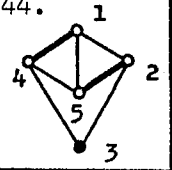
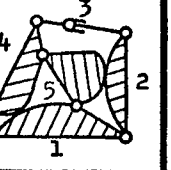
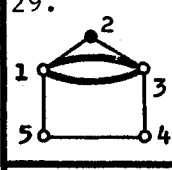
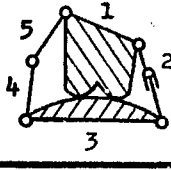
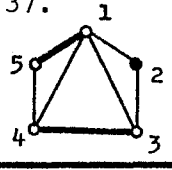
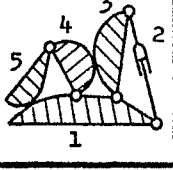
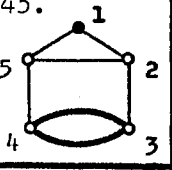
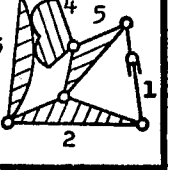
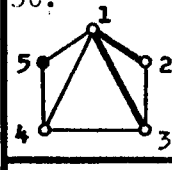
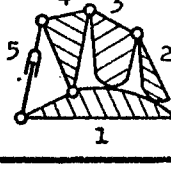
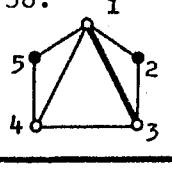
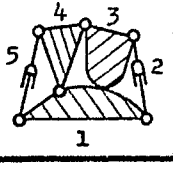
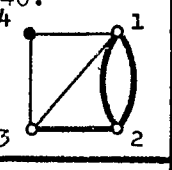
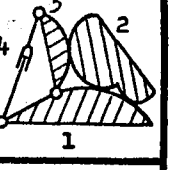
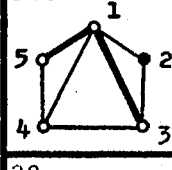
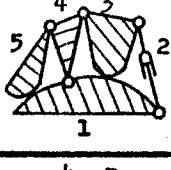
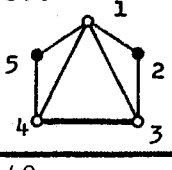
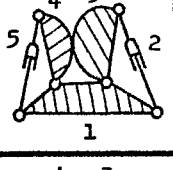
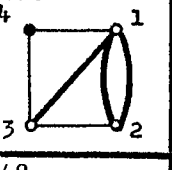
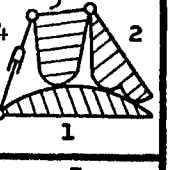
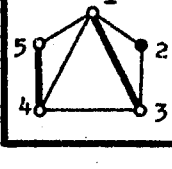
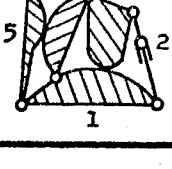
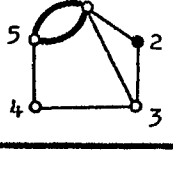
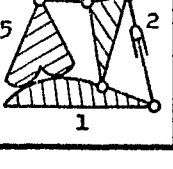
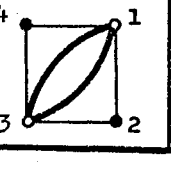
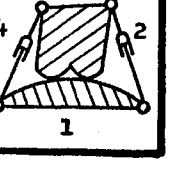
25. 		33. 		41. 	
26. 		34. 		42. 	
27. 		35. 		43. 	
28. 		36. 		44. 	
29. 		37. 		45. 	
30. 		38. 		46. 	
31. 		39. 		47. 	
32. 		40. 		48. 	

TABLE XIII (CONTINUED)

49. 		57. 		65. 	
50. 		58. 		66. 	
51. 		59. 		67. 	
52. 		60. 		68. 	
53. 		61. 		69. 	
54. 		62. 		70. 	
55. 		63. 		71. 	
56. 		64. 		72. 	



TABLE XIII (CONTINUED)

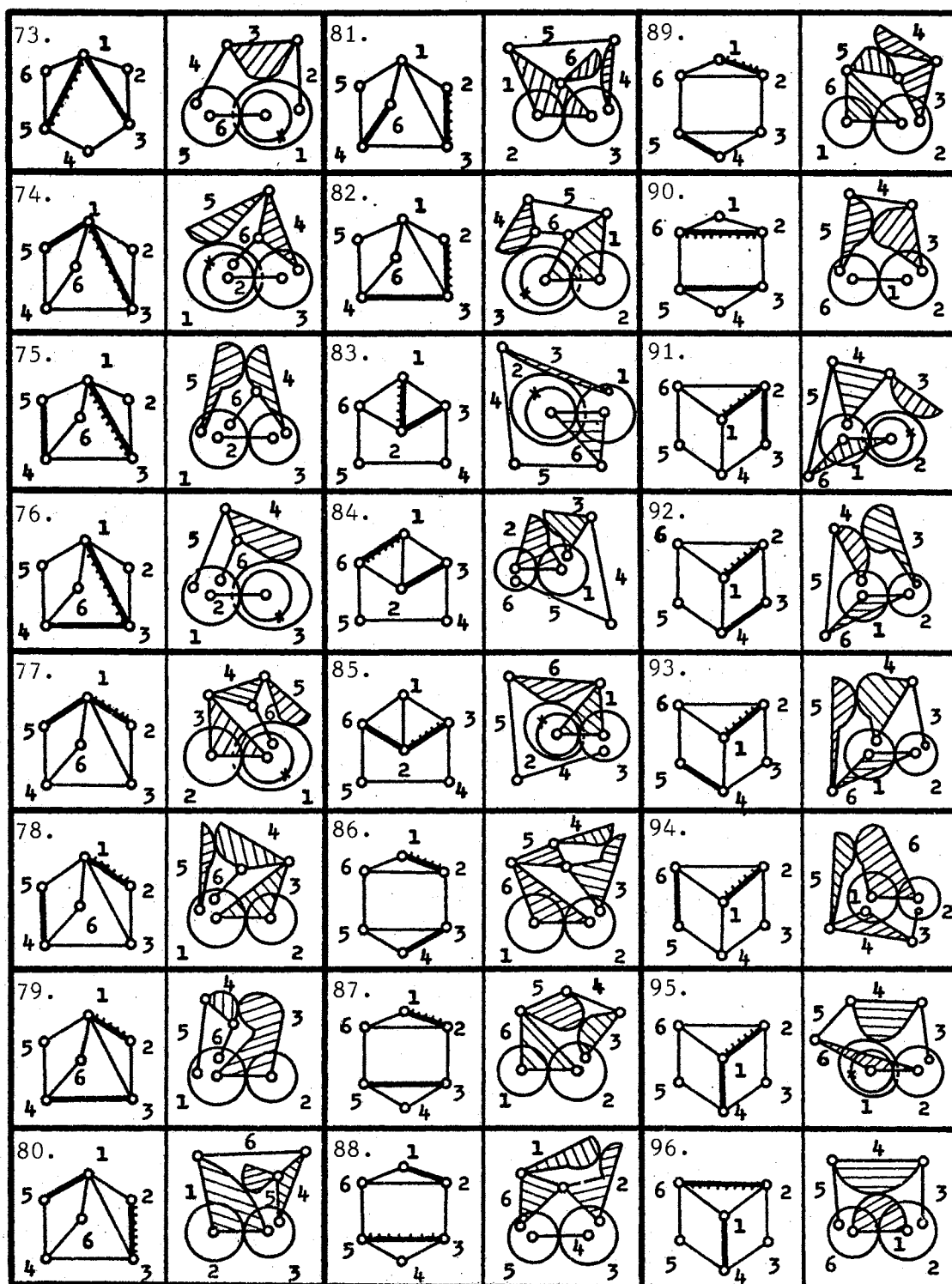


TABLE XIII (CONTINUED)

97. 		105. 		113. 	
98. 		106. 		114. 	
99. 		107. 		115. 	
100. 		108. 		116. 	
101. 		109. 		117. 	
102. 		110. 		118. 	
103. 		111. 		119. 	
104. 		112. 		120. 	

TABLE XIII (CONTINUED)

121. 		129. 		137. 	
122. 		130. 		138. 	
123. 		131. 		139. 	
124. 		132. 		140. 	
125. 		133. 		141. 	
126. 		134. 		142. 	
127. 		135. 		143. 	
128. 		136. 		144. 	

TABLE XIII (CONTINUED)

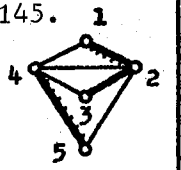
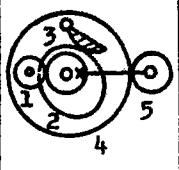
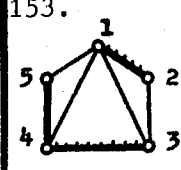
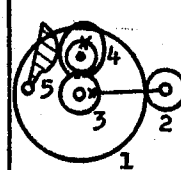
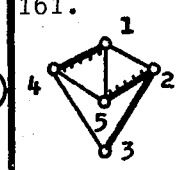
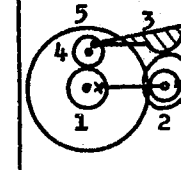
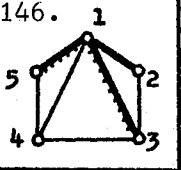
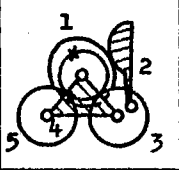
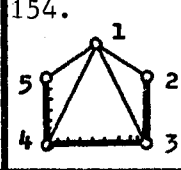
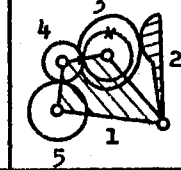
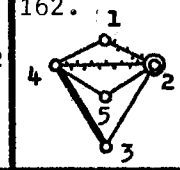
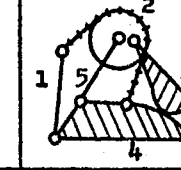
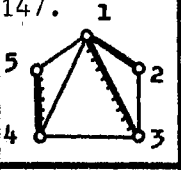
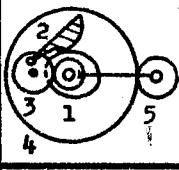
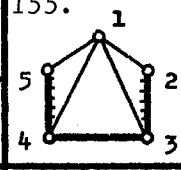
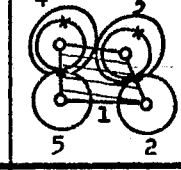
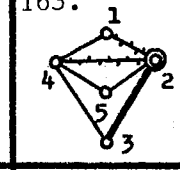
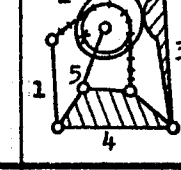
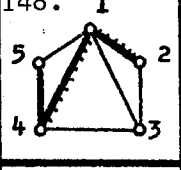
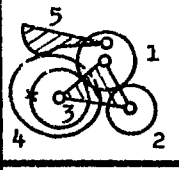
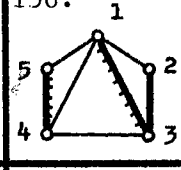
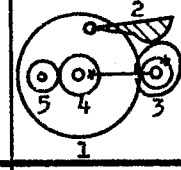
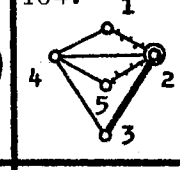
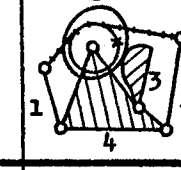
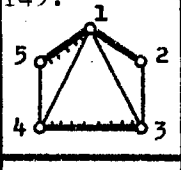
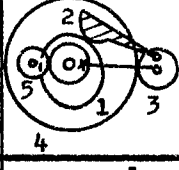
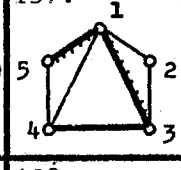
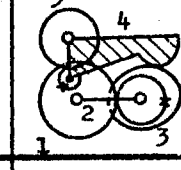
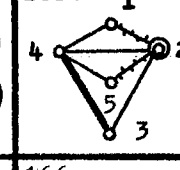
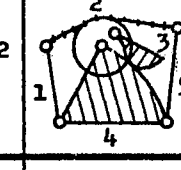
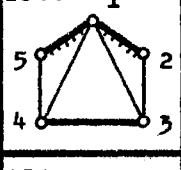
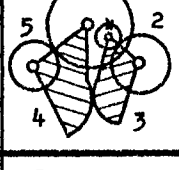
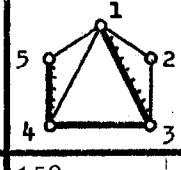
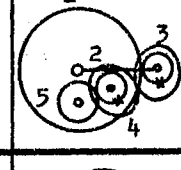
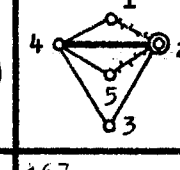
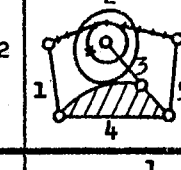
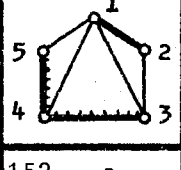
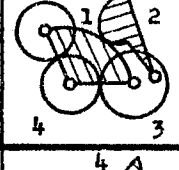
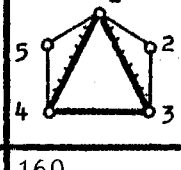
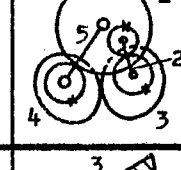
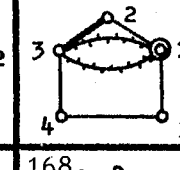
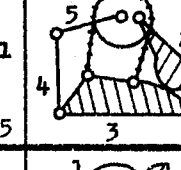
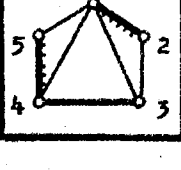
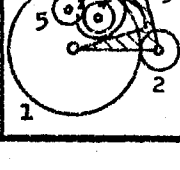
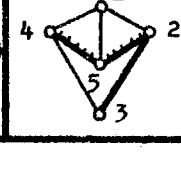
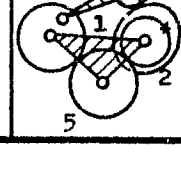
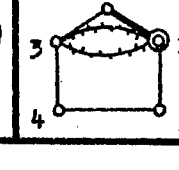
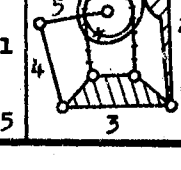
145. 1 		153. 1 		161. 1 	
146. 1 		154. 1 		162. 1 	
147. 1 		155. 1 		163. 1 	
148. 1 		156. 1 		164. 1 	
149. 1 		157. 1 		165. 1 	
150. 1 		158. 1 		166. 1 	
151. 1 		159. 1 		167. 2 	
152. 1 		160. 1 		168. 2 	

TABLE XIII (CONTINUED)

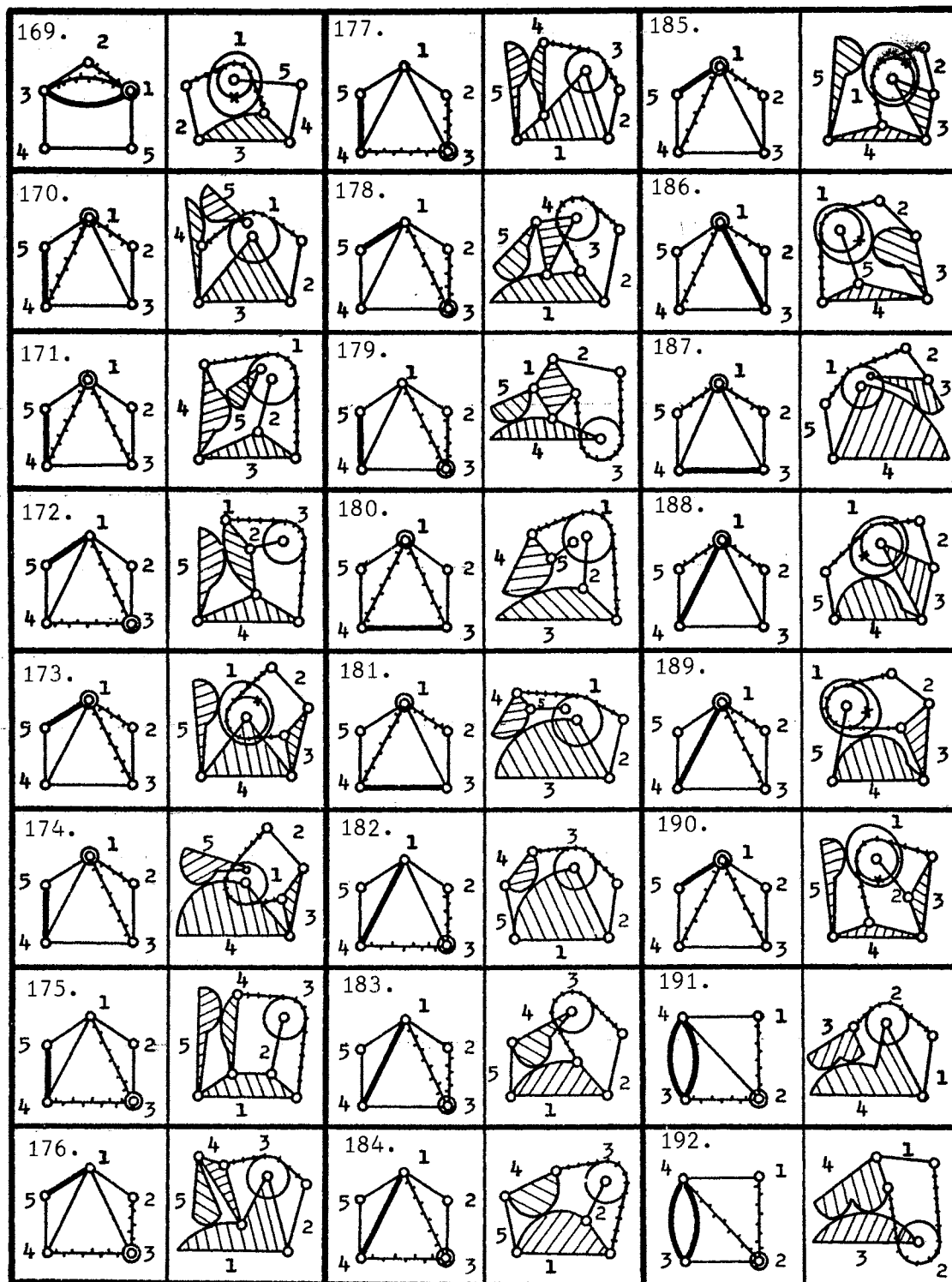


TABLE XIII (CONTINUED)

193. 		201. 		209. 	
194. 		202. 		210. 	
195. 		203. 		211. 	
196. 		204. 		212. 	
197. 		205. 		213. 	
198. 		206. 		214. 	
199. 		207. 		215. 	
200. 		208. 		216. 	

TABLE XIII (CONTINUED)

217. 		225. 	1 	233. 	
218. 		226. 	2 	234. 	
219. 		227. 	3 	235. 	
220. 		228. 	2 	236. 	
221. 		229. 	2 	237. 	
222. 		230. 	1 	238. 	
223. 		231. 	1 	239. 	
224. 		232. 	1 	240. 	

TABLE XIII (CONTINUED)

241. 	4 	249. 		257. 	
242. 		250. 		258. 	
243. 		251. 		259. 	
244. 		252. 		260. 	
245. 		253. 		261. 	
246. 		254. 		262. 	
247. 		255. 		263. 	
248. 		256. 		264. 	



TABLE XIII (CONTINUED)

265. 		273. 		281. 	
266. 		274. 		282. 	
267. 		275. 		283. 	
268. 		276. 		284. 	
269. 		277. 		285. 	
270. 		278. 		286. 	
271. 		279. 		287. 	
272. 		280. 		288. 	

TABLE XIII (CONTINUED)

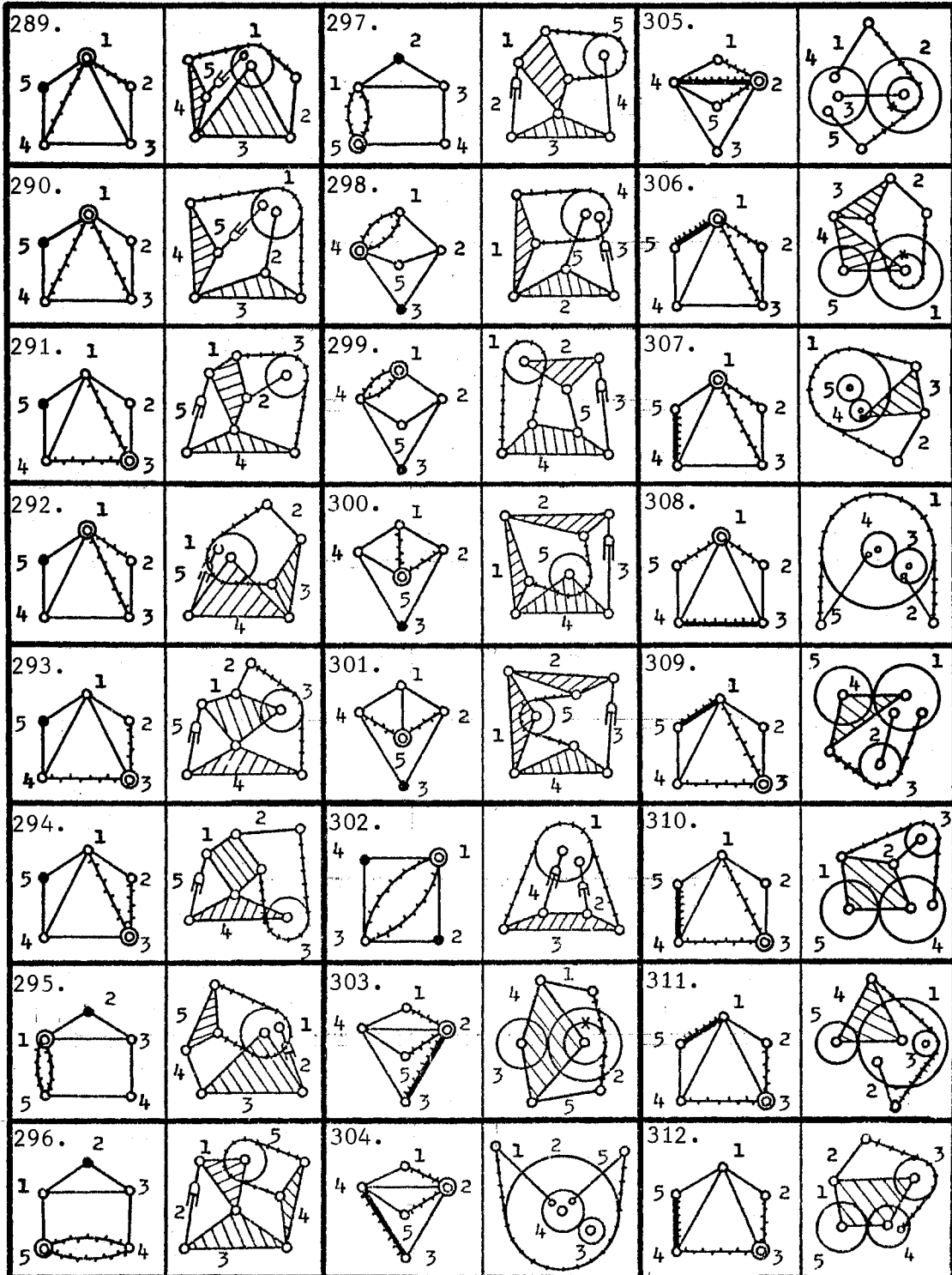


TABLE XIII (CONTINUED)

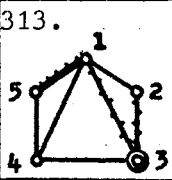
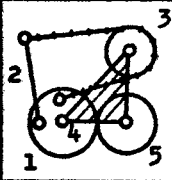
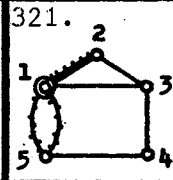
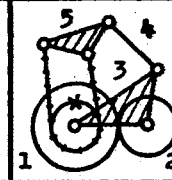
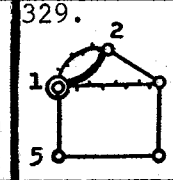
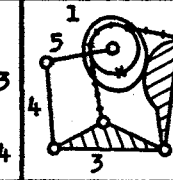
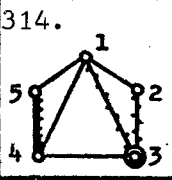
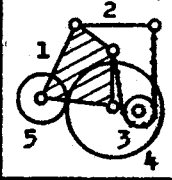
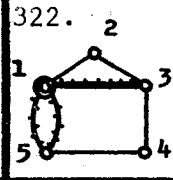
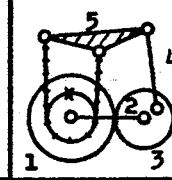
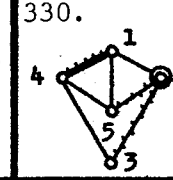
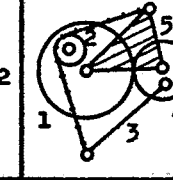
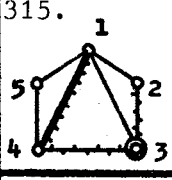
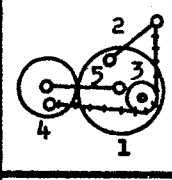
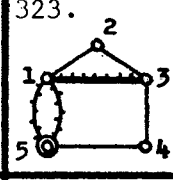
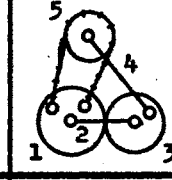
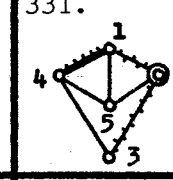
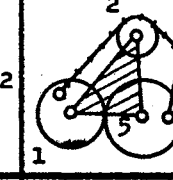
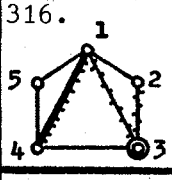
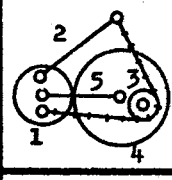
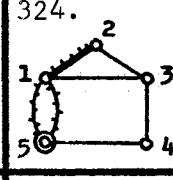
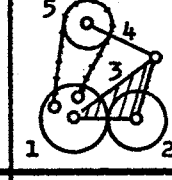
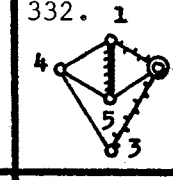
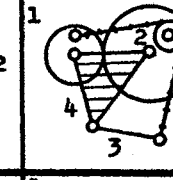
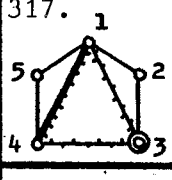
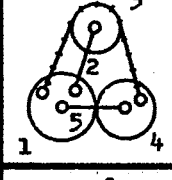
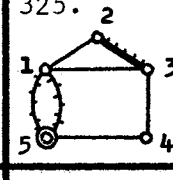
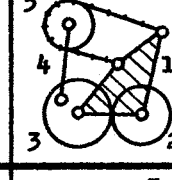
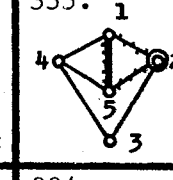
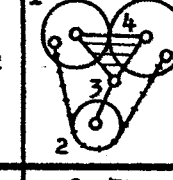
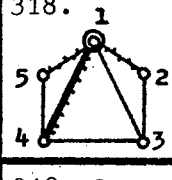
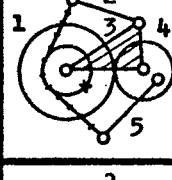
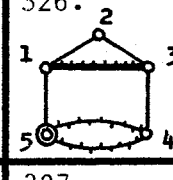
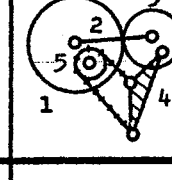
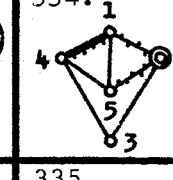
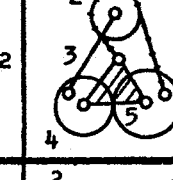
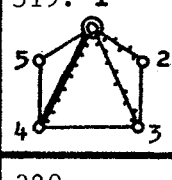
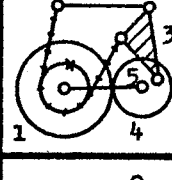
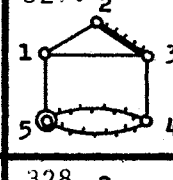
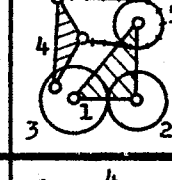
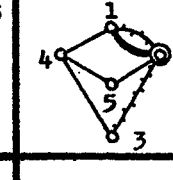
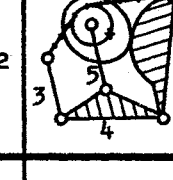
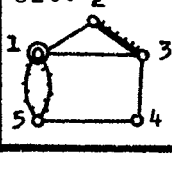
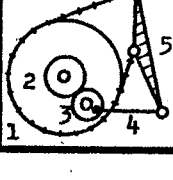
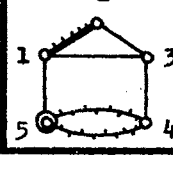
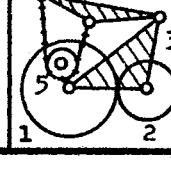
313. 		321. 		329. 	
314. 		322. 		330. 	
315. 		323. 		331. 	
316. 		324. 		332. 	
317. 		325. 		333. 	
318. 		326. 		334. 	
319. 		327. 		335. 	
320. 		328. 			

TABLE XIV

COLORED GRAPHS AND KINEMATIC CHAINS  
WITH THREE KINEMATIC ELEMENTS

1.		9.		17.	
2.		10.		18.	
3.		11.		19.	
4.		12.		20.	
5.		13.		21.	
6.		14.		22.	
7.		15.		23.	
8.		16.		24.	

TABLE XIV (CONTINUED)

25. 		33. 			
26. 		34. 			
27. 		35. 			
28. 		36. 			
29. 		37. 			
30. 		38. 			
31. 		39. 			
32. 					

## CHAPTER VIII

### SUMMARY AND CONCLUSIONS

The present work is devoted to exploring the application of graph theory in structural synthesis of kinematic chains with all types of kinematic elements. The present study develops a general mathematical model which permits one to undertake the structural synthesis of kinematic chains with different kinematic elements and their combinations. The kinematic elements under consideration are cam pairs, prism pairs, gears, springs, belt-pulleys and piston-cylinders.

The general mathematical model includes three general algorithms, which are:

- (1) Listing of specifications of  $n$ -colored graphs. The specification is expressed in terms of the sets of degrees of vertices of  $n$ -subgraphs. Given the number of vertices and edges in a colored graph, the listing of the specifications can be generated. A computer program has been developed to list all the possible specifications and is shown in Program A, Appendix B. The lower and the upper bounds of the specifications can also be specified in the program in order to reject those unacceptable specifications. The listing of specifications only provides the information about the number of ways of combining the degrees of vertices, it does not provide the ways of connecting the vertices in a graph, therefore, the following algorithm is required.

(2) Synthesis of vertex-vertex (v-v) incidence matrices of linear and non-linear n-colored graphs from a given specification. The synthesis of v-v incidence matrices of linear and non-linear n-colored graphs can be accomplished by considering each subgraph specification individually. The procedures to synthesize the v-v incidence matrices for each subgraph have been presented in Chapter III. All the possible ways of superposing the v-v incidence matrices of n subgraphs become the final v-v incidence matrices of n-colored graphs. A general computer program which consists of one main program and five subroutines has been developed and is shown in Program B, Appendix B. Since not all v-v incidence matrices synthesized are non-isomorphic, they have to go through the process of isomorphism test.

(3) Isomorphism test for a pair of linear or non-linear n-colored graphs. An algorithm for testing isomorphism of a pair of linear or non-linear n-colored graphs with colored vertices and colored edges has been presented in Chapter IV. The method of incidence tables is used and the total number of possibilities of finding the graph isomorphism is described. A general computer program, Program C, which consists of one main program and five subroutines has been developed and is presented in Appendix B.

Before applying the mathematical model to synthesize kinematic chains, the graphical representations for the kinematic chains with different kinematic elements should be first created. In general, the kinematic chains with different kinematic elements are graphically represented by the linear and non-linear colored graphs with colored

vertices and colored edges. All the different colored graph representations for different kinematic chains have been proposed and shown in Chapter VI.

The relationships between the number of rigid links and turning joints of a parent kinematic chain and the number of vertices and edges of colored graphs have been established as general mobility equations. The mobility equations are useful not only in examining the mobility of kinematic chains, but also in solving the sets of numbers of colored vertices and colored edges required in synthesizing colored graphs.

Given the number of rigid links and turning joints of a parent chain, the sets of numbers of colored vertices and colored edges can be generated from the mobility equations. Since the number of vertices and edges in colored graphs has been found, all the non-isomorphic colored graphs can be obtained by going through the synthesis procedures established by the general mathematical model.

The total number of colored graphs synthesized for a given number of vertices and edges in colored graphs can be checked by the application of Polya's theory of counting. The theory provides the exact count of colored graphs for a given number of vertices and edges in the colored graphs.

Since not all colored graphs synthesized generate the closed and isokinetic chains [32] (non-isokinetic chains are also called fractionated chains [101]), the criteria are developed to reject those unacceptable colored graphs.

Since the general mathematical model is based on the theoretical approach, it can be applied, without loss of generality, to enumerate systematically all the colored graphs and their corresponding kinematic



chains. The general mathematical model has been extensively tested and proved to be correct. The model has been tested on the kinematic chains with different kinematic elements developed from parent 8 link and 10 joint chains. The design tables consisting of colored graphs and their corresponding kinematic chains have been shown in Chapter VII.

In summary, the present study provides the following technical contributions to the field of kinematics:

1. Colored graph representations for the kinematic chains with different kinematic elements have been established. The kinematic elements under consideration are cam pairs, prism pairs, piston-cylinders, gears, springs and belt-pulleys. In general, the colored graph possesses colored vertices and colored edges. The kinematic elements such as piston-cylinder, spring and pulley have been represented by different colored vertices. The kinematic elements such as cam pair, prism pair, gear and belt have been represented by different colored edges.
2. General mobility equation for the kinematic chains with different kinematic elements has been set up which is expressed in terms of degree of freedom, different colored vertices and colored edges. The mobility equation not only provides the examination of the mobility of kinematic chains, but also provides the solution of sets of numbers of colored vertices and edges required in synthesizing colored graphs.
3. A general mathematical model which takes into account the synthesis procedures of colored graphs has been set up and implemented on general computer programs. The model consists of three general

- algorithms, they are (1) Listing of colored graph specifications (2) Synthesis of v-v incidence matrices of colored graphs from a given specification, and (3) Colored graph isomorphism test.
4. Criteria have been developed to reject those unacceptable colored graphs which correspond to the open kinematic chains or non-isokinetic chains.
  5. The model has been tested on the kinematic chains with different kinematic elements which are developed from parent 8 link and 10 joint chains. The design tables with colored graphs and their corresponding kinematic chains are presented.

Since the mathematical model developed in this study is based upon graph theory, it may be of interest to all those who are concerned with the mathematical analysis and synthesis of structures in the fields of system science.

In the field of mechanical networks particularly, the following research subject appears to be most promising.

Structural synthesis of kinematic chains with arbitrary numbers of

- (1) Kinematic loops,  $\lambda = 2, 3, 4, 5$ .
- (2) General constraints,  $m = 0, 1, 2, 3, 4$ .
- (3) Degrees of freedom,  $f = -1, 0, 1, 2, 3$ .
- (4) Different kinematic pairs,  $P_k$ ,  $k = 1, 2, 3, 4, 5$ .

It should be noted that the enumeration of spatial kinematic chains for the following cases has been undertaken by several authors as have been mentioned in Chapter I.

## 1. Soni and Harrisberger [29, 30]

- |                   |                              |
|-------------------|------------------------------|
| (1) $\lambda = 1$ | (2) $m = 0, 1$               |
| (3) $f = 1$       | (4) $P_k, k = 1, 2, 3, 4, 5$ |

## 2. Dobrjanskyj and Freudenstein [33, 34, 35]

- |                   |                        |
|-------------------|------------------------|
| (1) $\lambda = 1$ | (2) $m = 0$            |
| (3) $f = 1$       | (4) $P_k, k = 1, 2, 3$ |

## 3. Soni [21]

- |                      |                                |
|----------------------|--------------------------------|
| (1) $\lambda = 2, 3$ | (2) $m = 1, 2$                 |
| (3) $f = 1, 2$       | (4) $P_1$ (helical pairs only) |

The structural synthesis of spatial kinematic chains is essentially same as that of planar kinematic chains. Both spatial and planar kinematic chains can be graphically represented by colored graphs. The enumeration of colored graphs can be accomplished by the use of the general mathematical model developed in this study. After applying criteria and rejecting those unacceptable colored graphs (unworkable combinations), one is able to obtain all the acceptable colored graphs and the corresponding spatial kinematic chains with the four constraints described above.

## BIBLIOGRAPHY

1. Berge, C., "The Theory of Graphs and Its Application," John Wiley & Sons Inc., N.Y., 1962.
2. Busacker, R. G. and Saaty, T. L., "Finite Graphs and Networks: An Introduction with Applications," McGraw-Hill Book Co., N.Y., 1965.
3. Seshu, S. and Reed, M. B., "Linear Graphs and Electrical Networks," Addison-Wesley Publishing Co., 1961.
4. Polya, G., "Kombinatorische Anzahlbestimmungen fuer Gruppen, Graphen und chemische Verbindungen," ACTA Mathematica, Vol. 68, 1937, pp. 145-254.
5. Uhlenbeck, G. E. and Ford, G. W., "The Theory of Linear Graphs with Applications to the Theory of the Virial Development of the Properties of Gases," pp. 123-211, Part B in "Studies in Statistical Mechanics," V. 1, Edited by Boer, J. De, and Uhlenbeck, G. E., North-Holland Publishing Co. - Amsterdam, 1962.
6. Sussenguth, E., Jr., "A Graph Theoretical Algorithm for Matching Chemical Structures," J. Chem. Doc. 5, 1, Feb. 1965, pp. 36-43.
7. Reuleaux, F., "The Kinematics of Machinery," Dover Publications, N.Y., 1963.
8. Frank, R., "Vom Aufbau der Getriebe, II. Band, Die Baulehre Der Getriebe," Vdi-Verlag, 1951.
9. Frank, R., "Vom Aufbau der Getriebe, I. Band, Die Entwicklungslehre Der Getriebe," Vdi-Verlag, 1958.
10. Davies, T. H. and Crossley, F. E., "Structural Analysis of Plane Linkages by Franke's Condensed Notation," Journal of Mechanisms, V. 1, 1966, pp. 171-183.
11. Alt, H., "Die praktische Bedeutung der Raeumgetriebe," Z. VDI., Vol. 73, 1929, pp. 188-190.
12. Gruebler, M., "Getrieblehre eine Thedrie des Zwanglaufes und der eben Mechanismen." Berlin, Springer, 1917/1921.

13. Gruebler, M., "Das Kriterium der Zwanglaueufigkeit der Schraubenkettten," Festschrift, O. Mdhr Zum. 80, Geburtstag, Berlin, W. Ernst, U Sohn, 1916.
14. Gruebler, M., "Ueber raeumlichekinematische Ketten Kleinster Gliederzahl, sprach Geheimrat," Z. VDI., Bd. 71, 1927, p. 165.
15. Malytcheff, A. P., "Analysis and Synthesis of Mechanisms with the Viewpoint of Their Structure," Izvestya Tomskord of Technological Institute, 1923.
16. Kutzbach, K., "Bewegliche Verbindungen Vdrtrag, gehalten auf der Tagung fuer Maschinen Elemente," Z. VDI., Bd. 77, 1933, pp. 1168.
17. Kutzbach, K., "Quer- und winkelbewegliche wellunkupplungen," kraftfahrtechn, Fdrsch-Arb., Heft. 6, Berlin, 1937.
18. Kutzbach, K., "Quer- und winkelbewegliche Gleichgangglenke Fuer Wellenleitungen," Z. VDI., Bd. 81, Nr. 30, July, 1937.
19. Artobolevski, I. I., Thekria Mechanismow 1 Masin, Cosudarstv, Izdarl Tehn-Tedri. lit, Moscow, 1953.
20. Dobrovol'ski, W. W., Tedria Mechanismow, Maschgis, Moscow, 1953.
21. Soni, A. H., "Structural Analysis of Two General Constraint Kinematic Chains and Their Practical Application," Journal of Engineering for Industry, Feb. 1971, pp. 231-238.
22. Hain, Kurt and Zielstorff, A. W., "Die zwanglaeufigen achtgliedrigen Getriebe mit Einfach- und Mehrfachgelenken," Maschinenmarkt, Wuerzburg, 70, JG. (1964), Nr. 64, S. 12-28.
23. Assur, L. V., Collected works on the Study of Plane Pivoted Mechanisms with Lower Pairs (Russian) edited by I. I. Artobolevskii, Moscow; Akad. Nank, 1952.
24. Assur, L. V., "An Investigation of Coplanar Linkage Mechanisms with the Least Joints from the Viewpoint of Structure and Classification," (in Russian), Izdat. Akad. Nauk SSSR, 1952.
25. Manolescu, N. I., "For a United Point of Views in the Study of the Structural Analysis of Kinematic Chains and Mechanisms," Journal of Mechanisms, V. 3, 1968, pp. 149-169.
26. Haas, S. L. and Crossley, F. R. E., "Structural Synthesis of a Four-Bit Binary Adding Mechanism," Journal of Engineering for Industry, Feb. 1969, pp. 240-250.

27. Davies, T. H., "An Extension of Manolescu's Classification of Planar Kinematic Chains and Mechanisms of Mobility  $M > 1$ , Using Graph Theory," Journal of Mechanisms, V. 3, 1968, pp. 87-100.
28. Davies, T. H., "Systematic Pair-Reduction Procedure for Constraint Problems," ASME Mechanism Conference, 68-MECH-59.
29. Harrisberger, L., "Number Synthesis Survey of Three-Dimensional Mechanisms," Journal of Engineering for Industry, May, 1965, pp. 213-220.
30. Harrisberger, L. and Soni, A. H., "A Survey of Three-Dimensional Mechanisms with One General Constraint," ASME, Paper no. 66-MECH-44.
31. Woo, L. S., "Type Synthesis of Plane Linkages," Journal of Engineering for Industry, Feb. 1967, pp. 159-172.
32. Crossley, F. R. E., "The Permutation of Kinematic Chains of Eight Members or Less from the Graph-Theoretic Point," Developments in Theoretical and Applied Mechanics, V. 2, Proc. of 2nd Southeastern Conf. on Theoretical and Applied Mechanics, Atlanta, Georgia, Mar. 5-6, 1964, pp. 467-486.
33. Freudenstein, F. and Dobrjanskyj, L., "On a Theory for Type Synthesis of Mechanisms," Trans. of the XI International Congress of Applied Mechanics, Springer, Verlag (1964), pp. 420-428.
34. Dobrjanskyj, L. and Freudenstein, F., "Some Applications of Graph Theory to the Structural Analysis of Mechanisms," Journal of Engineering for Industry, Feb. 1967, pp. 153-158.
35. Dobrjanskyj, L., "Application of Graph Theory to the Structural Classification of Mechanisms," Doctoral Dissertation, Columbia University, 1966.
36. Hain, Kurt, "The Production of Large Oscillating Angles by Cam-Linkage Mechanisms," Proceedings-International Conf. on Mechanisms - Yale University, 1961, pp. 64-90.
37. Hain, Kurt, "Die Weiterleitung von Bewegungen und Kraefte durch Gewindespindeln," Landtechnische Forschung 6 (1956) Heft 1 S. 1-14.
38. Hain, Kurt, "Systematik sechsgliedriger kinematischer Ketten," Maschinenmarkt, Wuerzburg, JG. 74 (1968), Nr. 38, S. 717-723.
39. Hain, Kurt, "Kraefte und Bewegungen in Krafthebvergetrieben," Grundlagen d. Landtechnik H, 6, 12, Konstrukteurheft (1955) S. 45-68.

40. Hain, Kurt, "Sechsgliedrige periodische Bandgetriebe (Zugmittelgetriebe)," Konstruktion 6 (1954), S. 145-150.
41. Hain, Kurt, "Der Federausgleich von Lasten," Grundlagen d, Landtechnik H, 3, 10, Konstrukteurheft (1952) S. 38-50.
42. Hain, Kurt, "Gelenkarme Bandgetriebe fuer den Kraftausgleich durch Federn," Grundlagen d, Landtechnik H, 4, 11, Konstrukteurheft (1953), S. 100-109.
43. Hain, Kurt, "Die Bewegungsverhaeltnisse in Raederkurbelgetrieben mit fuefngliedrigen Grundgetrieben," der Maschinenmarkt 61 (1955), Nr. 78, S. 6-8.
44. Hain, Kurt and Marx, G., "Bewegungs- und Kraefteverhaeltnisse in kombinierten Ketten- und Kurbelgetrieben," Industrie-Anzeiger 81 (1959), Nr. 33, S. 499-501.
45. Johnson, R. C. and Towfigh, K., "Creative Design of Epicyclic Gear Trains Using Number Synthesis," Journal of Engineering for Industry, May, 1967, 309-314. ✓
46. Levai, Z., "Structure and Analysis of Planetary Gear Trains," Journal of Mechanisms, V. 3, 1968, 131-148. ✓
47. Benford, R. L., "Numerical Rules for Designing Planetary Gears," Machine Design, Aug. 1958, 129-136. ✓
48. Tuplin, W. A., "Compound Epicyclic Gear Trains," Machine Design, April 4, 1957, 100-104. ✓
49. Spotts, M. F., "Adjustable Speed Epicyclic Gear Trains," Machine Design, Feb. 1, 1962. ✓
50. Chironis, N. P., "Rearranged Linkages Create New Planetary Gear Systems," Product Engineering, Feb. 13, 1967, pp. 70-73.
51. Buchsbaum, F., "Structural Classification and Type Synthesis of Mechanisms with Multiple Elements," Doctoral Dissertation, Columbia University, 1967.
52. Buchsbaum, F. and Freudenstein, F., "Synthesis of Kinematic Structure of Geared Kinematic Chains and other Mechanisms," Journal of Mechanisms, V. 5, 1970, pp. 357-392. X
53. Bruijn, N. G., "Polya's Theory of Counting," pp. 144-184, in "Applied Combinatorial Mathematics," edited by E. G. Beckenbach, John Wiley & Sons, Inc., N.Y., 1964.
54. Freudenstein, F., "The Basic Concepts of Polya's Theory of Enumeration, with Application to the Structural Classification of Mechanisms," Journal of Mechanisms, V. 3, 1967, pp. 275-290. X

55. Quist, F., "Structural Synthesis and Analysis of Kinematic Chains Using Path Matrices," Master Thesis, Oklahoma State University, 1970.
56. Liu, C. L., "Introduction to Combinatorial Mathematics," McGraw-Hill, 1968.
57. Riordan, J., "An Introduction to Combinatorial Analysis," John Wiley & Sons, Inc., N.Y., 1958.
58. Whitney, H., "Separable and Planar Graphs," Trans. Am. Math. Soc. 34, 1932.
59. Whitney, H., "Planar Graphs," Fundam. Math. 21, 1933, pp. 73-84.
60. Malik, N. R. and Lee, Y. Y., "Finding Trees and Signed Tree Pairs by the Compound Method," 10th Midwest Symposium on Circuit Theory, Purdue University, May 18-19, 1967.
61. Unger, S. H., "GIT-A Heuristic Program for Testing Pairs of Directed Line Graphs for Isomorphism," Communication of the ACM, V. 7, No. 1, Jan. 1964, pp. 26-34.
62. Goodman, R. G., "A Computer Algorithm for Testing the Isomorphic Properties of Linear Graphs," Master Thesis, Oklahoma State University, 1965.
63. Goodman, R. G. and Cummins, R. L., "Computer Determination of Isomorphisms in Linear Graphs," Proc. 8th Midwest Symposium on Circuit Theory, Colorado State University, Fort Collins, Colo., June 1965.
64. Cornell, D. G. and Gotlieb, C. C., "An Efficient Algorithm for Graph Isomorphism," J. of the Asso. for Computing Machinery, V. 17, N. 1, Jan. 1970, pp. 51-64.
65. Gotlieb, C. C. and Cornell, D. G., "Algorithms for Finding a Fundamental Set of Cycles for an Undirected Linear Graph," Communications of the ACM, V. 10, N. 12, Dec. 1967.
66. Grace, D. W., "Computer Search for Non-Isomorphic Convex Polyhedra," Doctoral Dissertation, Stanford University, 1964.
67. Freudenstein, F., "An Application of Boolean Algebra to the Motion of Epicyclic Drives," Journal of Engineering for Industry, Feb. 1971, pp. 176-182.
68. Gruebler, M., *Getriebelehre*, 1917, Berlin.
69. Alt, H., "Zur Synthese der ebenen Mechanismen," ZAMM, Vol. 1, No. 5, 1921, pp. 373-398.



70. Bagci, Cemil, "Degrees of Freedom of Motion in Mechanisms," Journal of Engineering for Industry, Feb. 1971, pp. 140-148.
71. Bottema, O., "On Gruebler's Formulae for Mechanisms," Applied Scientific Research, V. 2, No. 2, 1950, pp. 162-164.
72. Bottema, O. and Freudenstein, F., "Kinematics and the Theory of Mechanisms," Applied Mechanics Surveys, Spartan Books.
73. Bruyr, D. L., "An Introduction to Graph Theory," Doctoral Dissertation, Oklahoma State University, 1965.
74. Chen, F. Y. and Chen, W. K., "On the Realizability of Permutational Synthesis of Mechanisms," ASME Mechanism Conference, 70-MECH-58.
75. Chen, W. K., "Generation of Trees and K-Trees," Proc. of Third Allerton Conf. on Circuit and System Theory, Oct. 1965.
76. Coxeter, H. S. M., "Self-Dual Configurations and Regular Graphs," Am. Math. Soc., 56, 1950, pp. 413-455.
77. Crossley, F. E., "A Contribution to Gruebler's Theory in the Number Synthesis of Plane Mechanisms," Journal of Engineering for Industry, Feb. 1964, pp. 1-8.
78. Gilbert, E. N., "Enumeration of Labelled Graphs," Can. J. Math. 8, 1956, pp. 405-411.
79. Hain, Kurt, "Challenge: To Design Better Cams," Journal of Mechanisms, V. 5, 1970, pp. 283-286.
80. Hain, Kurt, "Systematik und Kinematik der Ladegerate mit Zwei Schubkolben-Zylindern fuer den Lasthub," Grundl. Landtechn. Bd. 18 (1968), Nr. 2, S. 47-53.
81. Hain, Kurt, "Die Analyse und Synthese der Achtgliedrigen Gelenkgetriebe," VDI-Berichte Bd. 5, 1955, S. 81-93.
82. Hain, Kurt, "Hohere Winkelubertragungen in Sechs- und Achtgliedrigen, zwanglaufigen Getrieben," Maschinenmarkt, Wurzburg, 71, 1965, Nr. 3, S. 18-23.
83. Hain, Kurt, "Die Hoheren Koppelenen der Sechs- und Achtgliedrigen, zwanglaufigen getriebe," Maschinenmarkt, Wurzburg, 70. Jg. (1964), Nr. 81, S. 19-28.
84. Hain, Kurt, "Applied Kinematics," McGraw-Hill Book Co., 1967.
85. Hakimi, S. L., "On Trees of a Graph and Their Generation," J. of Franklin Inst., Vol. 272, No. 5, Nov. 1961, pp. 347-359.

86. Harary, F., "Graph Theory," Addison-Wesley Pub. Co., Reading, Mass., 1969.
87. Harary, F., "On the Number of Bicolored Graphs," Pacific J. Math., 8, 1958, pp. 743-755.
88. Harary, F., "The number of Linear, Directed, Rooted, and Connected Graphs," Trans. Am. Math. Soc., 78, 1955, pp. 445-463.
89. Hartenberg, R. S. and Denavit, J., "Kinematic Synthesis of Linkages," McGraw-Hill Co., N.Y., 1964.
90. Jensen, P. W., "The Missing Link: An Extension of Gruebler's Theory," ASME Mechanism Conference, 70-MECH-70.
91. Koenig, H. E. and Blackwell W. A., "Electromechanical System Theory," McGraw-Hill Book Co. Inc., 1961.
92. Mayeda, W. and Seshu, S., "Generation of Trees without Duplication," IEEE Trans. on Circuit Theory, Vol. CT-12, June, 1965, pp. 181-185.
93. Molian, S., "Storage and Retrieval of Descriptions of Mechanisms and Mechanical Devices According to Kinematic Type," Journal of Mechanisms, V. 4, 1969, pp. 311-323.
94. Molian, S., "Notation and General Equations for the Kinematics of Planar Mechanisms," J. Mech. Eng'g Science, V. 9, No. 4, 1969, pp. 311-323.
95. Ore, O., "Graph Theory," Vol. 1, Colloquium Publication of the American Mathematical Society, 1962.
96. Ore, O., "Graphs and Their Uses," Random House, The L. W. Singer Co., 1963.
97. Otter, R., "The Number of Trees," Annals of Mathematics, V. 49, N. 3, July 1948, pp. 583-599.
98. Paul, B., "A Unified Criterion for the Degree of Constraint of Plane Kinematic Chains," Journal of Applied Mechanics, March 1960, pp. 196-200.
99. Ryser, H. T., "Combinatorial Mathematics," John Wiley & Sons, N.Y., 1963.
100. Sheehan, J., "On the Number of Graphs with a Given Automorphism Group," Theory of Graphs, Proc. of the Colloquium Held at Tihany, Hungary, Sept. 1966, pp. 271-277.

101. Soni, A. H. and Harrisberger, L., "Applied Mechanisms-Synthesis, Kinematics, Dynamics," Preliminary Edition, School of Mechanical Engineering, Oklahoma State Univ. 1969.
102. Soni, A. H., "The Existence Criteria of One-General Constraint Mechanisms," Doctoral Dissertation, Oklahoma State University, May 1967.
103. Trent, H. M., "A Note on the Enumeration and Listing of All Possible Trees in a Connected Linear Graphs," Proc. Natl. Acad. Sci. US. V. 40, 1954, pp. 1004-1007.

## APPENDIX A

### KINEMATIC GRAPHS OF PARENT EIGHT LINK CHAINS

There are sixteen parent constrained eight link chains [22, 32, 68, 69]. The kinematic graphs of these kinematic chains are grouped together according to their specifications and are shown in Table XV.

Among the sixteen kinematic graphs, there are twelve kinematic graphs which can be obtained by adding the subgraph dyads (3 consecutive edges with two vertices in between) to the parent six link chains. They are shown as follows.

- (1) Those obtained by adding subgraph dyad (1234) to the Watt's kinematic graph (145678) are graphs (2), (6), (7), (10), (12), (15).
- (2) Those obtained by adding subgraph dyad (1234) to the Stephenson's kinematic graph (145678) are graphs (1), (3), (4), (11), (13), (14).

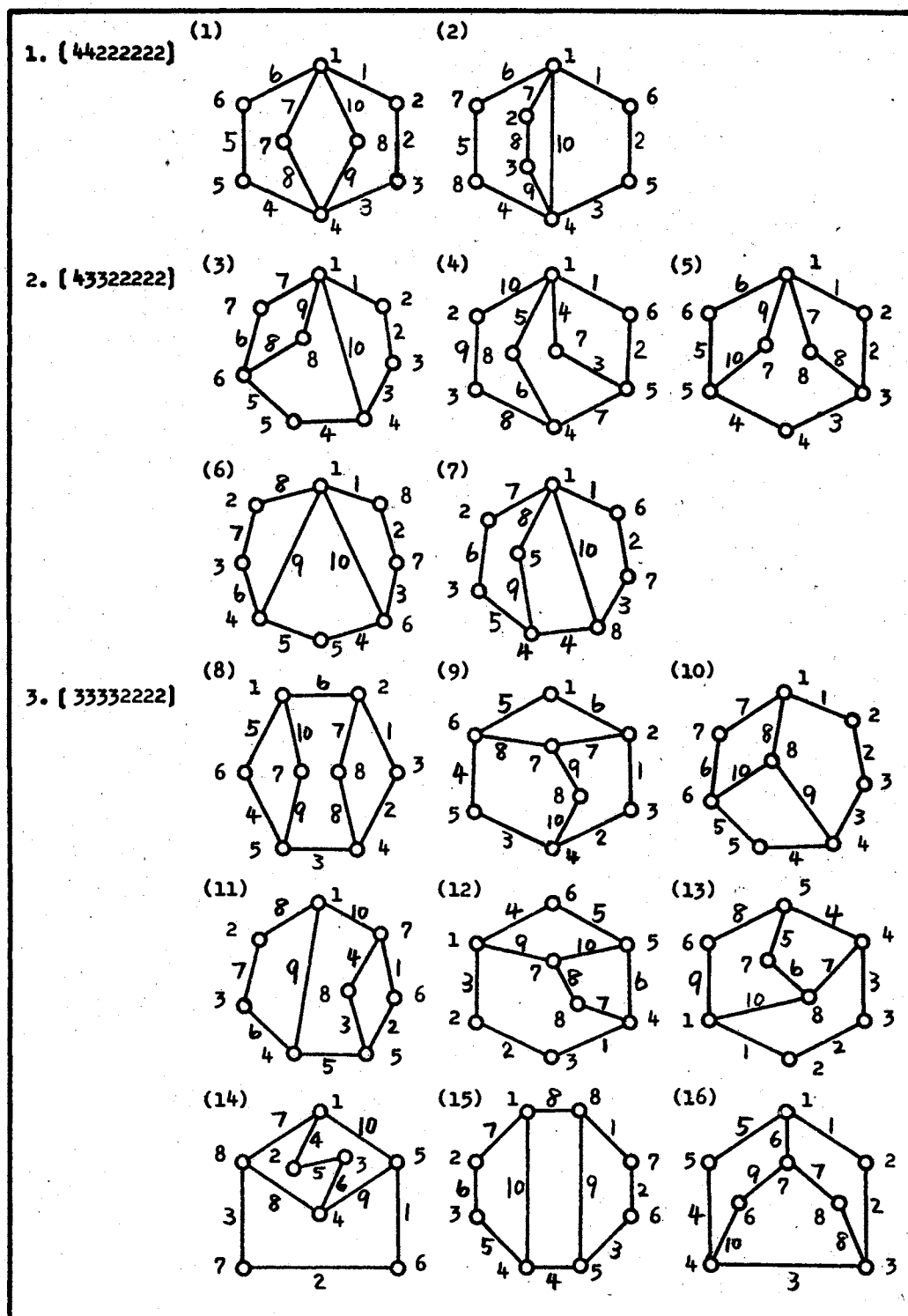
The remainder of the graphs (5), (8), (9), (16) are called unpeelable kinematic graphs. They can not be obtained by adding subgraph dyad to either Watt's or Stephenson's kinematic graph.

All the sixteen kinematic graphs have also been obtained by the use of the three general computer programs developed by the writer which are shown in Appendix B.

The lower bound of the degrees of vertices of a connected

TABLE XV

## SIXTEEN KINEMATIC GRAPHS OF PARENT 8 LINK CHAINS



graph<sup>1</sup> is 2, and the upper bound of the degrees of vertices is equal to half the number of rigid links, that is,  $\ell/2 = 8/2 = 4$ . Therefore, the listing of the specifications can be found from computer program A.

Since the different specifications have been found, the v-v incidence matrices can be synthesized by using computer program B. The computer program C is then used to check the isomorphism between those v-v incidence matrices. All the non-isomorphic v-v incidence matrices are the representations of the non-isomorphic graphs needed for parent 8 link chains.

---

<sup>1</sup>The graph of a closed kinematic chain is always a connected graph.

## APPENDIX B

### COMPUTER PROGRAMS

Three general computer programs listed on the following pages are based on the methods described in Chapter III and IV. Six examples and their outputs are explained in Chapter V.

The three computer programs are

(I) Program A: Listing of Colored Graph Specifications.

There are one main program and three subroutines, 1, 2 and 3 as shown below.

(II) Program B: Synthesis of Vertex-Vertex Incidence Matrices of Colored Graphs..

There are one main program and five subroutines, 1, 2, 3, 4 and 5 as shown below.

(III) Program C: Colored Graph Isomorphism Test.

There are one main program and five subroutines, 1, 6, 7, 8 and 9 as shown below.

There are total 9 different subroutines used in the three programs, they are

1. PERMU: PERMU finds all the possible permutations for a given number of objects. The total number of permutations for given  $j$  objects is  $j!$ .
2. PERMU1: PERMU1 finds the total permutations for a set of specifications. The number of NP objects having I, J, ... like terms is

$NP!/I! \times J! \times \dots$ .  $NI$  is the number of different specifications,  $IP$  contains each of the specifications,  $IB1$  contains the total permutations from the different specifications and  $NC$  is the number of permutations.

3. COMB: COMB finds the combinations of objects in  $A, B, C, \dots$  (total  $K$  items). Let  $A1, B1, C1, \dots$  be the number of objects in  $A, B, C, \dots$ , then the total number of combinations is  $NI = A1 \times B1 \times C1 \times \dots$ . Output is stored at  $IQ (NI, K)$ .
4. DIST: DIST is a modified version of the main program in Program A. DIST distributes the number  $NB$  into  $NP$  places. Output is stored at  $IP (NR, NP)$ ,  $NR$  is the total number of distributions.
5. POSSI1: POSSI1 forms all the possible arrangements (combinations) of the numbers which are stored at  $IB1 (NC, NP)$  according to the decreasing number of  $IY (1, NP)$ . Output is stored at  $IH (IK, NP)$ ,  $IK$  is number of arrangements.
6. ORDER: ORDER rearranges the numbers in  $K (2, N)$  in increasing order. The sets of data in  $IS (2, 2, N)$  are also rearranged according to the new order of  $K (2, N)$ .  $N$  is the number of data.  $ID = 1$  is for one set of data in  $IS (2, 1, N)$ ,  $ID = 2$  for two sets of data in  $IS (2, 2, N)$ .  $JJ = 0$  means the numbers in  $K (1, N)$  are the same as those in  $K (2, N)$ .  $JJ = 1$ , the numbers in two groups are not same.
7. TABLE: TABLE finds the incidence table with the degrees of vertices in increasing order. Input data: one vertex number in Graph 1 and another vertex number in Graph 2 stored in  $IS1 (1, 1, 1)$  and  $IS1 (2, 1, 1)$  respectively. Return data:  $IV1, IS1, KW, JJ$ .  $IV1$  stores the degrees of vertices in increasing order.  $IS1 (IG, 1, KW)$  stores the vertex numbers of incidence table of Graph  $IG, IS1 (IG, 2, KW)$ ,



- the edge numbers. KW is the number of vertices (or edges) in incidence table. JJ = 0 means the degrees of vertices in two groups of incidence table are same. JJ = 1, not same.
8. POSSI: POSSI forms all the possible arrangements of the vertices in Graph 1 according to their degrees of vertices (in increasing order). IY (1, NV) stores the degrees of vertices of Graph 1. IS1 (1, 1, NV) stores the corresponding vertex numbers. All the possible arrangements are stored at IP (NI, NV), where NI is the total number of arrangements, NV is number of vertices.
9. CHECK: CHECK checks whether the edge elementary matrix is completed and whether the transformation equation is satisfied. MM = 1 means edge elementary matrix has not completed yet, tests should be continued. MM = 2, transformation equation is not satisfied, go to pick up another isomorphic possibility. MM = 3, two graphs are isomorphic.

The preparations of the data cards for the three computer programs are explained below:

(I) Program A:

Card 1: NEX, number of examples. (I5)

Card 2: NCO, number of different colors. (I5)

Card 3: NB: number to be distributed, NP: number of places in specification, ML: lower bound of specification, MU: upper bound of specification. (4I5)

Card 4: Repeat NB, NP, ML, MU for other colored subgraphs.

Card 5: Repeat from Card 2, if NEX > 1.

## (II) Program B:

Card 1: NEX, number of examples. (I5)

Card 2: NCO, number of types of colored edges. (I5)

Card 3: NV, number of vertices. (I5)

Card 4, ... , specifications for each colored subgraph. (16I5)

Card ... : Repeat from Card 2, if  $NEX > 1$ .

## (III) Program C:

Card 1: NEX, number of examples. (I5)

Card 2: NV, number of vertices. (I5)

Card 3: NT, number of types of colored edges. (I5)

Card 4: KV (I),  $I = 1, \dots, NV$ , types of vertices of first graph. (16I5) (1: fine vertex (rigid link), 2: vertex for piston-cylinder, 3: vertex for spring, 4: vertex for pulley (wheel), 5: vertex for the fixed link in mechanism)

Card 5, ..., (total  $NV - 1$  cards), each card is for each row of  $v-v$  matrix. Only the elements on the upper triangle of matrix are read in (excluding the zeros in diagonal).  
(16I5)

Repeat from Card 4 for the data of second graph.

Repeat from Card 2, if  $NEX > 1$ .

```

C   PROGRAM A: LISTING OF SPECIFICATIONS OF COLORED GRAPHS.
COMMON IP(250,6),IH(120,5),IB1(30,5),NPERMU
DIMENSION IP1(5,50,6),IN(10),IP2(1,50,6),IQ(200,5)
DIMENSION IZ(8),ICK(200)
50 FORMAT(4I5)
52 FORMAT(' NUMBER          NB=',I3,' ',I3,' NUMBER OF PLACES NP=',I3,/,
1' LOWER BOUND ML=',I3,' ',I3,' UPPER BOUND      MU=',I3,/)
53 FORMAT(' * DATA OF COLORED-',I2,' SUBGRAPH *',/)
58 FORMAT(I3,'.',10I5)
99 FORMAT(/,' SPECIFICATION',I4,'.',//,4X,8(3X,I1,'.'),/)
120 FORMAT(IH1,' * EXAMPLE',I3,' *',/)
300 FORMAT(/,' THE NUMBER OF SPECIFICATIONS =',I3,/)
DO 130 I=1,8
130 IZ(I)=1
READ (5,50) NEX
DO 100 IKZ=1,NEX
WRITE(6,120) IKZ
READ(5,50) NCO
DO 37 KC=1,NCO
WRITE(6,53) KC
READ(5,50) NB,NP,ML,MU
WRITE(6,52) NB,NP,ML,MU
IF(NCO.EQ.1.OR.KC.GT.1) GO TO 33
CALL PERMU(NP)
33 NP1=NP-1
NP2=NP-2
IC1=NP1
DO 27 J=1,200
DO 27 I=1,NP1
27 IP(J,I)=ML
IP(1,NP)=NB-ML*NP1
NR=(IP(1,NP)-ML)/2+1
IF(NR.LT.2) GO TO 30
DO 21 I=2,NR
J=I-1
DO 25 K=1,NP2
25 IP(I,K)=IP(J,K)
IP(I,NP)=IP(J,NP)-1
21 IP(I,NP1)=IP(J,NP1)+1
IF(NP.LE.2) GO TO 30
16 IF(IP(NR,NP1).LE.IP(NR,NP)) GO TO 56
NR=NR-1
GO TO 30
56 IC1=IC1-1
IF(IC1.LT.1) GO TO 30
NR=NR+1
DO 23 I=IC1,NP1
23 IP(NR,I)=1+ML
IP(NR,NP)=NB-ML*(IC1-1)-(NP1-IC1+1)*(1+ML)
47 IG=NP1
44 NR=NR+1
NR1=NR-1
DO 45 I=1,IG
45 IP(NR,I)=IP(NR1,I)
IP(NR,IG)=IP(NR1,IG)+1
DO 12 I=IG,NP1
12 IP(NR,I)=IP(NR,IG)
IP(NR,NP)=NB
DO 14 I=1,NP1

```

```

14 IP(NR,NP)=IP(NR,NP)-IP(NR,I)
   IF(IP(NR,IG).LT.IP(NR,NP)) GO TO 10
   IF(IP(NR,IG).EQ.IP(NR,NP)) GO TO 40
   NR=NR-1
40 IG=IG-1
   IF(IG.LT.IC1) GO TO 16
   GO TO 44
10 NR=NR+1
   NRI=NR-1
   DO 18 I=1,NP2
18 IP(NR,I)=IP(NRI,I)
   IP(NR,NP)=IP(NRI,NP)-1
   IP(NR,NP1)=IP(NRI,NP1)+1
   IF(IP(NR,NP1).LT.IP(NR,NP)) GO TO 10
   IF(IP(NR,NP1).EQ.IP(NR,NP)) GO TO 47
   NR=NR-1
   GO TO 47
30 NRU=0
   NRI=0
62 NRU=NRU+1
60 IF(NRU.GT.NR) GO TO 31
   IF(IP(NRU,NP).GT.MU) GO TO 62
   NRI=NRI+1
   DO 64 I=1,NP
64 IP(NRI,I)=IP(NRU,I)
   GO TO 62
31 IF(NCO.GT.1) GO TO 110
   WRITE(6,300) NRI
   DO 112 I=1,NRI
   WRITE(6,99) I,(I2(I9),I9=1,NP)
112 WRITE(6,98) NCO,(IP(I,J),J=1,NP)
   GO TO 100
110 IF(NCO.LE.2.AND.KC.EQ.1) GO TO 135
   CALL PERMU1(NP,NRI,NC)
   IN(KC)=NC
   DO 80 I=1,NC
   DO 80 J=1,NP
80 IP1(KC,I,J)=IB1(I,J)
   GO TO 37
135 DO 140 I=1,NRI
   DO 140 J=1,NP
140 IP1(1,I,J)=IP(I,J)
   IN(1)=NRI
37 CONTINUE
   JC=0
   DO 102 I=1,NCO
   JB=IN(I)
   DO 102 J=1,JB
   JC=JC+1
   DO 102 I1=1,NP
102 IP2(1,JC,I1)=IP1(I,J,I1)
   CALL CEMB(NCO,IN,IQ,NI)
   DO 126 I=1,NI
126 ICK(I)=0
   NIC=0
210 NIC=NIC+1
   IF(NIC.GE.NI) GO TO 170
   IF(ICK(NIC).EQ.1) GO TO 210
   NID=NIC

```

```

150 NID=NID+1
   IF(NID.GT.NI) GO TO 210
   IF(ICK(NID).EQ.1) GO TO 150
   DO 228 I=1,NPERMU
   DO 230 K=1,NCO
   DO 230 J=1,NP
   IF(IP2(1,IQ(NIC,K),J).NE.IP2(1,IQ(NID,K),IH(I,J))) GO TO 228
230 CONTINUE
   GO TO 128
228 CONTINUE
   GO TO 150
128 ICK(NID)=1
   GO TO 150
170 NQA=0
   DO 132 I=1,NI
   IF (ICK(I).EQ.1) GO TO 132
   NQA=NQA+1
   DO 134 K=1,NCO
   DO 134 J=1,NP
134 IP1(K,NQA,J)=IP2(1,IQ(I,K),J)
132 CONTINUE
   WRITE(6,300) NQA
   DO 106 I=1,NQA
   WRITE(6,99) I,(IZ(I9),I9=1,NP)
   DO 106 J=1,NCO
106 WRITE(6,98) J,(IP1(J,I,I1),I1=1,NP)
100 CONTINUE
39 STOP
END
SUBROUTINE PERMU(NP,NI,NC)
COMMON IP(250,6),IH(120,5),IB1(30,5),NPERMU
DIMENSION IB(10,50,5),IG(40)
KC=NPERMU
NC=0
DO 32 I=1,NI
DO 30 J=1,KC
DO 30 K=1,NP
30 IB(I,J,K)=IP(I,IH(J,K))
DO 37 LH=1,KC
37 IG(LH)=0
LH=0
38 LH=LH+1
IF(LH.GT.KC) GO TO 44
IF(IG(LH).EQ.1) GO TO 38
IH1=LH
36 IH1=IH1+1
IF(IH1.GT.KC) GO TO 38
IF(IG(IH1).EQ.1) GO TO 36
NP1=0
40 NP1=NP1+1
IF(NP1.GT.NP) GO TO 42
IF(IB(I,LH,NP1).EQ.IB(I,IH1,NP1)) GO TO 40
GO TO 36
42 IG(IH1)=1
GO TO 36
44 LH=0
45 LH=LH+1
IF(LH.GT.KC) GO TO 32
IF(IG(LH).EQ.1) GO TO 45

```

```

      NC=NC+1
      DO 46 II=1,NP
46  IB1(NC,II)=IB(I,LH,II)
      GO TO 45
32  CONTINUE
      RETURN
      END
      SUBROUTINE PERMU(J)
      COMMON IP(250,6),IH(120,5),IB1(30,5),NPERMU
      DIMENSION IT(5)
      IT(1)=1
      DO 30 I=2,5
30  IT(I)=I*IT(I-1)
      IH(1,1)=1
      IH(1,2)=2
      IH(2,1)=2
      IH(2,2)=1
      NPERMU=2
      IF(J.EQ.2) RETURN
      K=3
22  K1=K-1
      KT=IT(K1)
      DO 10 I1=1,KT
10  IH(I1,K)=K
      KC=KT
      DO 20 I5=1,K1
      I2=K1-I5+1
      DO 20 I4=1,KT
      KC=KC+1
      IH(KC,K)=I2
      KM=1
25  IF(IH(I4,KM).NE.I2) GO TO 17
      IH(KC,KM)=K
      GO TO 23
17  IH(KC,KM)=IH(I4,KM)
23  KM=KM+1
      IF(KM.GT.K1) GO TO 20
      GO TO 25
20  CONTINUE
      K=K+1
      IF(K.LE.J) GO TO 22
      NPERMU=KC
      RETURN
      END
      SUBROUTINE COMB(K,IN,IQ,NI)
      COMMON IP(250,6),IH(120,5),IB1(30,5),NPERMU
      DIMENSION IN(10),IQ(200,5),IR(5,24),IW(72,2)
      KCO=0
      DO 3 IK=1,K
      I=IN(IK)
      DO 3 J=1,I
      KCO=KCO+1
      IR(IK,J)=KCO
      IW(KCO,1)=IK
      IW(KCO,2)=J
3  CONTINUE
      NR=1
      K1=K-1
      IF(K1.LT.2) GO TO 32

```

```
DO 4 I=2,K1
4 NR=NR*IN(I)
M1=NR
MT=IN(1)*IN(K)
DO 6 I1=2,K1
M1=M1/IN(I1)
MC=NR/(M1*IN(I1))
NI=0
DO 6 I5=1,MT
DO 6 I2=1,MC
MN=IN(I1)
DO 6 I3=1,MN
DO 6 I4=1,M1
NI=NI+1
IQ(NI,I1)=IR(I1,I3)
6 CONTINUE
32 NI=0
N1=IN(1)
NK=IN(K)
DO 8 I1=1,N1
DO 8 I2=1,NK
DO 8 I3=1,NR
NI=NI+1
IQ(NI,K)=IR(K,I2)
IQ(NI,1)=IR(1,I1)
8 CONTINUE
RETURN
END
```

## \* EXAMPLE 1 \*

## \* DATA OF COLORED-1 SUBGRAPH \*

NUMBER NB= 14, NUMBER OF PLACES NP= 6  
 LOWER BOUND ML= 1, UPPER BOUND MU= 9

THE NUMBER OF SPECIFICATIONS = 20

SPECIFICATION 1.  
 1. 1 1 1 1 1 9

SPECIFICATION 3.  
 1. 1 1 1 1 3 7

SPECIFICATION 5.  
 1. 1 1 1 1 5 5

SPECIFICATION 7.  
 1. 1 1 1 2 3 6

SPECIFICATION 9.  
 1. 1 1 1 3 3 5

SPECIFICATION 11.  
 1. 1 1 2 2 2 6

SPECIFICATION 13.  
 1. 1 1 2 2 4 4

SPECIFICATION 15.  
 1. 1 1 3 3 3 3

SPECIFICATION 17.  
 1. 1 2 2 2 3 4

SPECIFICATION 19.  
 1. 2 2 2 2 2 4

SPECIFICATION 2.  
 1. 1 1 1 1 2 8

SPECIFICATION 4.  
 1. 1 1 1 1 4 6

SPECIFICATION 6.  
 1. 1 1 1 2 2 7

SPECIFICATION 8.  
 1. 1 1 1 2 4 5

SPECIFICATION 10.  
 1. 1 1 1 3 4 4

SPECIFICATION 12.  
 1. 1 1 2 2 3 5

SPECIFICATION 14.  
 1. 1 1 2 3 3 4

SPECIFICATION 16.  
 1. 1 2 2 2 2 5

SPECIFICATION 18.  
 1. 1 2 2 3 3 3

SPECIFICATION 20.  
 1. 2 2 2 2 3 3



## \* EXAMPLE 2 \*

## \* DATA OF COLORED-1 SUBGRAPH \*

NUMBER NB= 6, NUMBER OF PLACES NP= 4  
 LOWER BOUND ML= 1, UPPER BOUND MU= 3

## \* DATA OF COLORED-2 SUBGRAPH \*

NUMBER NB= 4, NUMBER OF PLACES NP= 4  
 LOWER BOUND ML= 0, UPPER BOUND MU= 2

THE NUMBER OF SPECIFICATIONS = 14

SPECIFICATION 1.  
 1. 1 1 1 3  
 2. 0 0 2 2

SPECIFICATION 3.  
 1. 1 1 1 3  
 2. 0 1 1 2

SPECIFICATION 5.  
 1. 1 1 1 3  
 2. 2 1 1 0

SPECIFICATION 7.  
 1. 1 1 2 2  
 2. 0 0 2 2

SPECIFICATION 9.  
 1. 1 1 2 2  
 2. 2 2 0 0

SPECIFICATION 11.  
 1. 1 1 2 2  
 2. 1 1 0 2

SPECIFICATION 13.  
 1. 1 1 2 2  
 2. 2 1 0 1

SPECIFICATION 2.  
 1. 1 1 1 3  
 2. 0 2 2 0

SPECIFICATION 4.  
 1. 1 1 1 3  
 2. 0 1 2 1

SPECIFICATION 6.  
 1. 1 1 1 3  
 2. 1 1 1 1

SPECIFICATION 8.  
 1. 1 1 2 2  
 2. 0 2 0 2

SPECIFICATION 10.  
 1. 1 1 2 2  
 2. 0 1 1 2

SPECIFICATION 12.  
 1. 1 1 2 2  
 2. 0 2 1 1

SPECIFICATION 14.  
 1. 1 1 2 2  
 2. 1 1 1 1

```

C   PROGRAM B: SYNTHESIS OF VERTEX-VERTEX INCIDENCE MATRICES.
COMMON IP(50,10),IW(25,2),IT(5)
DIMENSION IA(30,5),NT(5),IB1(30,5),IM(30,5),L(30),IZ(5),IA1(1,5),
IMM(6),MT(30,6),LS(30),ND(6),ME(20),MI(3,20,5,5),IH(24,5)
DIMENSION NQQ(10),IQ(20,5),MIC(20,5,5),ICK(20),NZ(9),INB(9)
10  FORMAT(10I5)
56  FORMAT(/,' * SPECIFICATION FOR COLORED-',I1,' SUBGRAPH:',8I3)
57  FORMAT(/,' * SPECIFICATION FOR THE',I2,'-COLORED GRAPH:',8I3)
87  FORMAT(' NO INCIDENCE MATRIX EXISTS FOR THE GIVEN SPECIFICATION')
95  FORMAT(/,' MATRIX NUMBER',I3)
98  FORMAT(I3,'.',10I5)
99  FORMAT(/,4X,8(3X,I1,'.'),/)
201 FORMAT(' EXAMPLE',I3,' (' ,I2,'-COLORED GRAPH HAVING',I2,
1' VERTICES )',/)
300 FORMAT(/,' THE NUMBER OF VERTEX-VERTEX INCIDENCE MATRICES =',I3)
IT(1)=1
DO 31 I=2,5
31  IT(I)=I*IT(I-1)
DO 100 I=1,5
100  IZ(I)=I
READ(5,10) NEX
DO 200 IEX=1,NEX
READ(5,10) NCO
READ(5,10) NV
WRITE(7,201) IEX,NCO,NV
DO 4 KKK=1,NCO
READ(5,10) (IA(I,IK),IK=1,NV)
IF(NCO.GE.2) GO TO 2
NV1=NV-1
DO 8 J=1,NV1
LL=NV-J+1
DO 8 I=2,LL
IF(IA(1,I-1)-IA(1,I)) 3,8,8
3  IMAX=IA(1,I)
IA(1,I)=IA(1,I-1)
IA(1,I-1)=IMAX
8  CONTINUE
WRITE(7,57) NCO,(IA(1,IK),IK=1,NV)
GO TO 55
2  WRITE(7,56) KKK,(IA(1,IK),IK=1,NV)
55  JY=0
NA=1
NY=1
NT(NY)=1
36  NP=NV-NY
IF(NP.LE.1) GO TO 60
NY=NY+1
NY1=NY-1
JC=NT(NY1)
NT(NY)=0
DO 50 IJ=1,JC
ISU=NT(NY)
IY=IY+1
N3=IA(IY,1)
IF(NR.NE.0) GO TO 38
NC1=1
NC=1
DO 40 I=1,NP
40  IB1(1,I)=0

```

```

GO TO 18
38 CALL DIST (NB, NP, NR)
   CALL PERMUL (NP, NR, IB1, NC)
   IF (NCO.GE.2) GO TO 42
   IF (NY1.NE.1) GO TO 42
   DO 5 I=2, NV
5   IA1(I, I-1)=IA(I, I)
   CALL POSSI1 (IA1, IB1, NP, NC, IH, NI)
   NC=NI
   DO 6 I=1, NI
   DO 6 J=1, NP
6   IB1(I, J)=IH(I, J)
42 NC1=0
13 NC1=NC1+1
   IF (NC1.GT.NC) GO TO 22
   NP1=0
16 NP1=NP1+1
   IF (NP1.GT.NP) GO TO 18
   J=NP1+1
   IF (IB1 (NC1, NP1).GT.IA(IY, J)) GO TO 13
GO TO 16
18 NA=NA+1
   NA1=NA-1
   NT(NY)=NT(NY)+1
   DO 14 I=1, NP
   IM (NA1, I)=IB1 (NC1, I)
   J=I+1
14 IA (NA, I)=IA (IY, J)-IB1 (NC1, I)
GO TO 13
22 L(IY)=NT(NY)-ISU
50 CONTINUE
   IF (NY.LT.3) GO TO 36
   IU=IY
   INB(NY)=0
430 IF (L(IU).NE.0) GO TO 36
   INB(NY)=INB(NY)+1
   IU=IU-1
GO TO 430
60 NZ(NY1)=NT(NY1)-INB(NY)
   NS=1
   NF=NT(2)
   DO 33 I=1, NF
33 LS(I)=1
   DO 61 I=3, NY
   J=I-1
   NF1=NT(J)
   DO 61 IX=1, NF1
   AS=NS+1
   JI=L(NS)
   IF (JI.LE.0) GO TO 61
   DO 82 IY=1, JI
   NF=NF+1
82 LS(NF)=NS
61 CONTINUE
   ND(NY)=NA1-NT(NY)-INB(NY)
   IF (NY.LE.3) GO TO 81
   ND(NY1)=ND(NY)-NZ(NY1)
   IF (NY1.EQ.3) GO TO 81
   DO 66 J2=5, NY

```

```

J=NY-J2+4
J1=J-1
66 ND(J1)=ND(J)-NT(J1)
81 NN=NA
MM(NY)=NA1
DO 70 J2=3,NY
J=NY-J2+3
J1=J-1
70 MM(J1)=MM(J)-NT(J)
IF(IA(NA,1).EQ. IA(NA,2).AND. IA(NA,1).LE.1) GO TO 65
KS=NT(NY)-1
NN=NA1
DO 63 KS1=1,KS
IF(IA(NN,1).EQ. IA(NN,2).AND. IA(NN,1).LE.1) GO TO 65
63 NN=NN-1
WRITE(7,87)
GO TO 200
65 MT(1,1)=NN-1
ME(1)=IA(NN,1)
MT(1,2)=ND(NY)-(LS(MM(NY))-LS(MT(1,1)))
DO 68 J2=4,NY
J=NY-J2+3
68 MT(1,J2-1)=ND(J)-(LS(MM(J))-LS(MT(1,J2-2)))-INB(J)
NN=NN-1
NQ=1
ICH=NA-NT(NY)+1
71 IF(NN.LE. ICH) GO TO 76
IF(IA(NN,1).NE. IA(NN,2)) GO TO 74
IF(IA(NN,1).GT.1) GO TO 74
NQ=NQ+1
ME(NQ)=IA(NN,1)
MT(NQ,1)=NN-1
MT(NQ,2)=ND(NY)-(LS(MM(NY))-LS(MT(NQ,1)))
DO 75 J2=4,NY
J=NY-J2+3
MT(NQ,J2-1)=ND(J)-(LS(MM(J))-LS(MT(NQ,J2-2)))-INB(J)
75 CONTINUE
74 NN=NN-1
GO TO 71
76 NY1=NY-1
DO 90 K=1,NQ
DO 90 I=1,5
90 MI(KKK,K,I,I)=0
NQ1=0
94 NQ1=NQ1+1
IF(NQ1.GT.NQ) GO TO 93
JV=NV
JV=JV-1
MI(KKK,NQ1,JV,NV)=ME(NQ1)
DO 92 IK=1,NY1
NPP=IK+1
JV=JV-1
DO 92 IJ=1,NPP
KJ=JV+IJ
92 MI(KKK,NQ1,JV,KJ)=IM(MT(NQ1,IK),IJ)
NV1=NV-1
DO 96 I=1,NV1
IJ=I+1
DO 96 J=IJ,NV

```

```

96 MI(KKK,NQ1,J,I)=MI(KKK,NQ1,I,J)
   GO TO 94
93 DO 126 I=1,NQ
125 ICK(I)=0
   NQC=0
110 NQC=NQC+1
   IF(NQC.GT.NQ) GO TO 130
   IF(ICK(NQC).EQ.1) GO TO 110
   NQB=NQC
120 NQB=NQB+1
   IF(NQB.GT.NQ) GO TO 110
   I=0
122 I=I+1
   IF(I.GE.NV) GO TO 128
   J=I
124 J=J+1
   IF(J.GT.NV) GO TO 122
   IF(MI(KKK,NQC,I,J).EQ.MI(KKK,NQB,I,J)) GO TO 124
   GO TO 120
128 ICK(NQB)=1
   GO TO 120
130 NQA=0
   DO 132 I=1,NQ
   IF(ICK(I).EQ.1) GO TO 132
   NQA=NQA+1
   DO 134 I1=1,NV
   DO 134 J1=1,NV
134 MI(KKK,NQA,I1,J1)=MI(KKK,I,I1,J1)
132 CONTINUE
   IF(NCO.GT.1) GO TO 302
   WRITE(7,300) NQA
302 DO 97 K=1,NQA
   WRITE(7,95) K
   WRITE(7,99) (IZ(I9),I9=1,NV)
   DO 97 I=1,NV
97 WRITE(7,98) I,(MI(KKK,K,I,J),J=1,NV)
   NQQ(KKK)=NQA
4 CONTINUE
   IF(NCO.EQ.1) GO TO 200
   JC=NQQ(1)
   DO 102 I=2,NCO
   JB=NQQ(I)
   DO 102 J=1,JB
   JC=JC+1
   DO 102 I1=1,NV
   DO 102 J1=1,NV
102 MI(I,JC,I1,J1)=MI(I,J,I1,J1)*10**(I-1)
   CALL COMB(NCO,NQQ,IQ,NI)
   WRITE(7,300) NI
   DO 107 I=1,NI
   DO 105 I1=1,NV
   DO 105 J1=1,NV
105 MIC(I,I1,J1)=0
   DO 104 J=1,NCO
   DO 106 I1=1,NV
   DO 106 J1=1,NV
106 MIC(I,I1,J1)=MIC(I,I1,J1)+MI(I,IQ(I,J),I1,J1)
104 CONTINUE
   WRITE(7,95) I

```

```

WRITE(7,99) (IZ(I9),I9=1,NV)
CO 112 I1=1,NV
112 WRITE(7,98) I1,(MIC(I,I1,J1),J1=1,NV)
107 CONTINUE
200 CONTINUE
STOP
END
SUBROUTINE DIST(NB,NP,NR)
COMMON IP(50,10),IW(25,2),IT(5)
DO 29 I=1,200
CO 29 J=1,6
29 IP(I,J)=0
NR=NB/2+1
NP1=NP-1
NP2=NP-2
IC1=NP1
IP(1,NP)=NB
IF(NR.LT.2) RETURN
CO 21 I=2,NR
IP(I,NP)=IP(I-1,NP)-1
21 IP(I,NP1)=IP(I-1,NP1)+1
IF(NP.LE.2) RETURN
16 IF(IP(NR,NP1).LE.IP(NR,NP)) GO TO 56
NR=NR-1
RETURN
56 IC1=IC1-1
IF(IC1.LT.1) RETURN
NR=NR+1
DO 23 I=IC1,NP1
23 IP(NR,I)=1
IP(NR,NP)=NB-(NP1-IC1+1)
47 IG=NP1
44 NR=NR+1
DO 45 I=1,IG
45 IP(NR,I)=IP(NR-1,I)
IP(NR,IG)=IP(NR-1,IG)+1
DO 12 I=IG,NP1
12 IP(NR,I)=IP(NR,IG)
IP(NR,NP)=NB
DO 14 I=1,NP1
14 IP(NR,NP)=IP(NR,NP)-IP(NR,I)
IF(IP(NR,IG).LT.IP(NR,NP)) GO TO 10
IF(IP(NR,IG).EQ.IP(NR,NP)) GO TO 40
NR=NR-1
40 IG=IG-1
IF(IG.LT.IC1) GO TO 16
GO TO 44
10 NR=NR+1
DO 18 I=1,NP2
18 IP(NR,I)=IP(NR-1,I)
IP(NR,NP)=IP(NR-1,NP)-1
IP(NR,NP1)=IP(NR-1,NP1)+1
IF(IP(NR,NP1).LT.IP(NR,NP)) GO TO 10
IF(IP(NR,NP1).EQ.IP(NR,NP)) GO TO 47
NR=NR-1
GO TO 47
END
SUBROUTINE PERMUL(NP,NI,IB1,NC)
COMMON IP(50,10),IW(25,2),IT(5)

```

```

DIMENSION IB(10,30,5), IQ(24,5), IG(40), IB1(30,5)
CALL PERMU(NP,IQ,KC)
NC=0
DO 32 I=1,NI
DO 30 J=1,KC
DO 30 K=1,NP
30 IB(I,J,K)=IP(I,IQ(J,K))
DO 37 IH=1,KC
37 IG(IH)=0
IH=0
38 IH=IH+1
IF(IH.GT.KC) GO TO 44
IF(IG(IH).EQ.1) GO TO 38
IH1=IH
36 IH1=IH1+1
IF(IH1.GT.KC) GO TO 38
IF(IG(IH1).EQ.1) GO TO 36
NP1=0
40 NP1=NP1+1
IF(NP1.GT.NP) GO TO 42
IF(IB(I,IH,NP1).EQ.IB(I,IH1,NP1)) GO TO 40
GO TO 36
42 IG(IH1)=1
GO TO 36
44 IH=0
45 IH=IH+1
IF(IH.GT.KC) GO TO 32
IF(IG(IH).EQ.1) GO TO 45
NC=NC+1
DO 46 II=1,NP
46 IB1(NC,II)=IB(I,IH,II)
GO TO 45
32 CONTINUE
RETURN
END
SUBROUTINE POSS1(IY,IB1,NV,NC,IH,IK)
COMMON IP(50,10),IW(25,2),IT(5)
DIMENSION IN(10), IQ(20,5),IB1(30,5),KL(10),
1LV(5,5),IVA(5,24,5),IY( 1,5),IH(24,5),IBB(20,15,5),ICK(40)
K=0
KCO=0
13 I=0
K=K+1
KL(K)=1
11 KCO=KCO+1
I=I+1
IF(KCO.GE.NV) GO TO 15
IF(IY(I,KCO).NE.IY(1,KCO+1)) GO TO 13
KL(K)=I+1
GO TO 11
15 DO 52 IJK=1,NC
KK=0
DO 21 I=1,K
K1=KL(I)
DO 21 J1=1,K1
KK=KK+1
LV(I,J1)=IB1(IJK,KK)
21 CONTINUE
DO 19 IK=1,K

```

```

      K1=KL(IK)
      IF(K1.GT.1) GO TO 17
      IVA(IK,1,1)=LV(IK,1)
      GO TO 19
17  CALL PERMU(K1,IH,KT)
      DO 20 J=1,KT
      DO 20 J1=1,K1
      IVA(IK,J,J1)=LV(IK,IH(J,J1))
20  CONTINUE
19  CONTINUE
      DO 2 I=1,K
      2  IN(I)=IT(KL(I))
      CALL COMB(K,IN,IQ,NI)
      DO 50 I1=1,NI
      N2=0
      DO 50 I2=1,K
      K1=KL(I2)
      DO 50 J1=1,K1
      N2=N2+1
      IK=IW(IQ(I1,I2),1)
      J=IW(IQ(I1,I2),2)
      IBB(IJK,I1,N2)=IVA(IK,J,J1)
50  CONTINUE
52  CONTINUE
      DO 60 IJK=1,NC
60  ICK(IJK)=0
      DO 61 IJK=1,NC
      IJA=IJK
      IF(ICK(IJK).EQ.1) GO TO 61
66  IJA=IJA+1
      IF(IJA.GT.NC) GO TO 61
      IK=0
62  IK=IK+1
      IF(IK.GT.NI) GO TO 66
      KI=1
65  NP=0
63  NP=NP+1
      IF(NP.GT.N2) GO TO 64
      IF(IBM(IJK,IK,NP).EQ.IBM(IJA,KI,NP)) GO TO 63
      KI=KI+1
      IF(KI.GT.NI) GO TO 62
      GO TO 65
64  ICK(IJA)=1
      GO TO 66
61  CONTINUE
      IK=0
      DO 70 IJK=1,NC
      IF(ICK(IJK).EQ.1) GO TO 70
      IK=IK+1
      DO 71 IL=1,N2
71  IH(IK,IL)=IBM(IJK,1,IL)
70  CONTINUE
      RETURN
      END
      SUBROUTINE PERMU(J,IH,KC)
      COMMON IP(50,10),IW(25,2),IT(5)
      DIMENSION IH(24,5)
      IH(1,1)=1
      IH(1,2)=2

```



```

      IH(2,1)=2
      IH(2,2)=1
      KC=2
      IF(J.EQ.2) RETURN
      K=3
22  K1=K-1
      KT=IT(K1)
      DO 10 I1=1,KT
10  IH(I1,K)=K
      KC=KT
      DO 20 I5=1,K1
      I2=K1-I5+1
      DO 20 I4=1,KT
      KC=KC+1
      IH(KC,K)=I2
      KM=1
25  IF(IH(I4,KM).NE.I2) GO TO 17
      IH(KC,KM)=K
      GO TO 23
17  IH(KC,KM)=IH(I4,KM)
23  KM=KM+1
      IF(KM.GT.K1) GO TO 20
      GO TO 25
20  CONTINUE
      K=K+1
      IF(K.LE.J) GO TO 22
      RETURN
      END
      SUBROUTINE COMB(K,IN,IQ,NI)
      COMMON IP(50,10),IW(25,2),IT(5)
      DIMENSION IN(10),IQ(20,5),IR(5,24)
      KCO=0
      DO 3 IK=1,K
      I=IN(IK)
      DO 3 J=1,I
      KCO=KCO+1
      IR(IK,J)=KCO
      IW(KCO,1)=IK
      IW(KCO,2)=J
3  CONTINUE
      NR=1
      K1=K-1
      IF(K1.LT.2) GO TO 32
      DO 4 I=2,K1
4  NR=NR*IN(I)
      M1=NR
      MT=IN(1)*IN(K)
      DO 6 I1=2,K1
      M1=M1/IN(I1)
      MC=NR/(M1*IN(I1))
      NI=0
      DO 6 I5=1,MT
      DO 6 I2=1,MC
      MN=IN(I1)
      DO 6 I3=1,MN
      DO 6 I4=1,M1
      NI=NI+1
      IQ(NI,I1)=IR(I1,I3)
6  CONTINUE

```

```
32 NI=0
   NI=IN(1)
   NK=IN(K)
   DO 8 I1=1,NI
   DO 8 I2=1,NK
   DO 8 I3=1,NR
   NI=NI+1
   IQ(NI,K)=IR(K,I2)
   IQ(NI,1)=IR(1,I1)
8 CONTINUE
RETURN
END
```

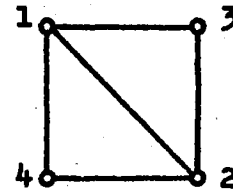
EXAMPLE 1 ( 1-COLORED GRAPH HAVING 4 VERTICES )

\* SPECIFICATION FOR THE 1-COLORED GRAPH: 3 3 2 2

THE NUMBER OF VERTEX-VERTEX INCIDENCE MATRICES = 4

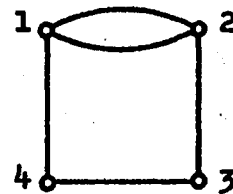
MATRIX NUMBER 1

	1.	2.	3.	4.
1.	0	1	1	1
2.	1	0	1	1
3.	1	1	0	0
4.	1	1	0	0



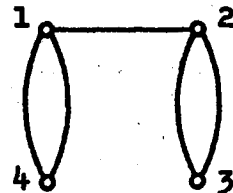
MATRIX NUMBER 2

	1.	2.	3.	4.
1.	0	2	0	1
2.	2	0	1	0
3.	0	1	0	1
4.	1	0	1	0



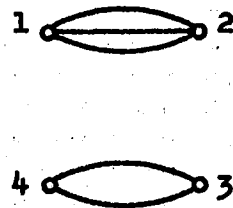
MATRIX NUMBER 3

	1.	2.	3.	4.
1.	0	1	0	2
2.	1	0	2	0
3.	0	2	0	0
4.	2	0	0	0



MATRIX NUMBER 4

	1.	2.	3.	4.
1.	0	3	0	0
2.	3	0	0	0
3.	0	0	0	2
4.	0	0	2	0

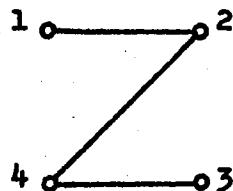


EXAMPLE 2 ( 2-COLORED GRAPH HAVING 4 VERTICES )

\* SPECIFICATION FOR COLORED-1 SUBGRAPH: 1 2 1 2

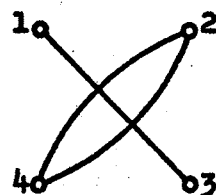
MATRIX NUMBER 1

	1.	2.	3.	4.
1.	0	1	0	0
2.	1	0	0	1
3.	0	0	0	1
4.	0	1	1	0



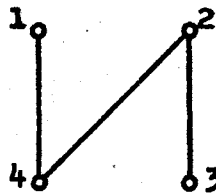
MATRIX NUMBER 2

	1.	2.	3.	4.
1.	0	0	1	0
2.	0	0	0	2
3.	1	0	0	0
4.	0	2	0	0



MATRIX NUMBER 3

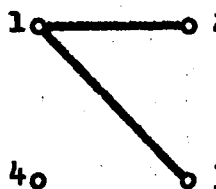
	1.	2.	3.	4.
1.	0	0	0	1
2.	0	0	1	1
3.	0	1	0	0
4.	1	1	0	0



\* SPECIFICATION FOR COLORED-2 SUBGRAPH: 2 1 1 0

MATRIX NUMBER 1

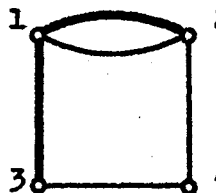
	1.	2.	3.	4.
1.	0	1	1	0
2.	1	0	0	0
3.	1	0	0	0
4.	0	0	0	0



THE NUMBER OF VERTEX-VERTEX INCIDENCE MATRICES = 3

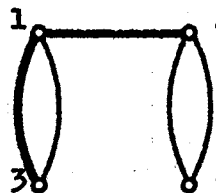
MATRIX NUMBER 1

	1.	2.	3.	4.
1.	0	11	10	0
2.	11	0	0	1
3.	10	0	0	1
4.	0	1	1	0



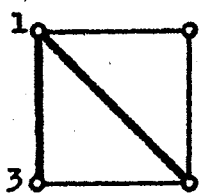
MATRIX NUMBER 2

	1.	2.	3.	4.
1.	0	10	11	0
2.	10	0	0	2
3.	11	0	0	0
4.	0	2	0	0



MATRIX NUMBER 3

	1.	2.	3.	4.
1.	0	10	10	1
2.	10	0	1	1
3.	10	1	0	0
4.	1	1	0	0



```

C   PROGRAM C: COLORED GRAPH ISOMORPHISM TEST.
      COMMON IVE(2,10,15),KEE(15,15),IA(2,10,10),KVE(10,10),
      IIB(2,15,2),IC(2,10),IV(2,10),IT(10),NV,KE
      DIMENSION KV(10,1),IVV(10,10),IS1(2,2,10),IV5(2,10),IP(40,10),
      IW(15),NE(2),IS2(2,2,10)
      9  FORMAT(10X,' VERTEX NUMBER',5X,10I6)
      20 FORMAT( /,' DEGREE OF VERTEX...',10I6,/)
      21 FORMAT(///,' THE NUMBER OF ARRANGEMENTS OF VERTICES IN GRAPH 1 IS'
      1,I3,' :')
      22 FORMAT(' POSSIBILITY',I5,'...',10I6)
      25 FORMAT(///,' GRAPH',I3,' DEGREE OF VERTEX ',10I6,/)
      38 FORMAT(///,' TWO GRAPHS ARE ISOMORPHIC',/, ' ISOMORPHISM IS FOUND
      1AT POSSIBILITY',I3,' OUT OF TOTAL',I3,' POSSIBILITIES')
      39 FORMAT(///,' TWO GRAPHS ARE ISOMORPHIC',/, ' ISOMORPHISM IS FOUND
      1AT POSSIBILITY',I3,' OUT OF TOTAL',I3,' POSSIBILITY')
      61 FORMAT(/,' POSSIBILITY',I5,' :')
      63 FORMAT(/,' THE DEGREES OF VERTICES IN TWO GRAPHS ARE DIFFERENT')
      81 FORMAT(7X,'LEADING VERTEX ',I6)
      82 FORMAT( 7X,'EDGE NUMBER',6X,':',10I6)
      83 FORMAT(7X,'VERTEX NUMBER',4X,':',10I6)
      84 FORMAT(7X,'DEGREE OF VERTEX ',10I6)
      90 FORMAT(/,' (',I2,')', ' INCIDENCE TABLE')
      91 FORMAT(/,7X,'GRAPH',I3,' :')
      97 FORMAT(/,' THE DEGREES OF VERTICES IN TWO GRAPHS ARE SAME')
      100 FORMAT(16I5)
      105 FORMAT(I8,' ',15I5)
      111 FORMAT(///,' THE TWO GRAPHS ARE NOT ISOMORPHIC')
      152 FORMAT(///,7X,'VERTEX ELEMENTARY MATRIX',/)
      156 FORMAT(///,7X,'EDGE ELEMENTARY MATRIX',/)
      190 FORMAT(12X,15(I4,'.'),///)
      192 FORMAT(///,' GRAPH',I3,' VERTEX-EDGE INCIDENCE MATRIX',///)
      193 FORMAT(///,' GRAPH',I3,' VERTEX-VERTEX INCIDENCE MATRIX',///)
      365 FORMAT(' * EXAMPLE',I3,' *')
      DO 47 I=1,15
      47 IW(I)=I
      IT(I)=1
      DO 40 I=2,10
      40 IT(I)=I*IT(I-1)
      READ(5,100) NEX
      DO 350 IJK=1,NEX
      WRITE(7,365) IJK
      DO 36 I=1,2
      DO 36 J=1,10
      DO 36 K=1,15
      36 IVE(I,J,K)=0
      READ(5,100) NV
      READ(5,100) NT
      DO 110 IG=1,2
      READ(5,100) ((KV(I,1),I=1,NV)
      NV1=NV-1
      KCO=2
      KE=0
      DO 35 I=1,NV
      35 IVV(I,I)=0
      DO 102 I=1,NV1
      READ(5,100) (IVV(I,J),J=KCO,NV)
      DO 37 L=KCO,NV
      37 IVV(L,I)=IVV(I,L)
      DO 104 K=KCO,NV

```

```

IF(IVV(I,K).EQ.0) GO TO 104
KE=KE+1
IVE(IG,I,KE)=IVV(I,K)
IVE(IG,K,KE)=IVV(I,K)
IB(IG,KE,1)=I
IB(IG,KE,2)=K
104 CONTINUE
KCO=KCO+1
102 CONTINUE
WRITE(7,193) IG
WRITE(7,190) (IW(I),I=1,NV)
DO 130 L=1,NV
130 WRITE(7,105) L,(IVV(L,M),M=1,NV)
NE(IG)=KE
WRITE(7,192) IG
WRITE(7,190) (IW(I),I=1,KE)
DO 106 M=1,NV
106 WRITE(7,105) M,(IVE(IG,M,L),L=1,KE)
DO 108 I=1,NV
IV(IG,I)=KV(I,1)*10**NT
DO 108 K=1,KE
IV(IG,I)=IV(IG,I)+IVE(IG,I,K)
108 CONTINUE
110 CONTINUE
IF(NE(1).EQ.NE(2)) GO TO 112
114 WRITE(7,111)
GO TO 350
112 CONTINUE
DO 120 IG=1,2
DO 120 J=1,NV
IV5(IG,J)=IV(IG,J)
IS1(IG,1,J)=J
120 CONTINUE
CALL ORDER(IV5,IS1,NV,1,JJ)
DO 10 IG=1,2
WRITE(7,25) IG,(IV5(IG,I),I=1,NV)
10 WRITE(7,9) (IS1(IG,1,I),I=1,NV)
IF(JJ.EQ.0) GO TO 60
WRITE(7,63)
GO TO 114
60 CALL POSSI(IV5,IS1,IP,NI)
WRITE(7,21) NI
WRITE(7,20) (IV5(1,I),I=1,NV)
DO 7 I=1,NI
7 WRITE(7,22) I,(IP(I,J),J=1,NV)
DO 117 IG=1,2
DO 117 I=1,NV
KN=0
DO 116 J=1,KE
IF(IVE(IG,I,J).EQ.0) GO TO 116
KN=KN+1
IA(IG,I,KN)=J
116 CONTINUE
IC(IG,I)=KN
117 CONTINUE
NI1=0
50 NI1=NI1+1
IF(NI1.GT.NI) GO TO 114
WRITE(7,61) NI1

```

```

DO 30 I=1,10
DO 30 J=1,10
30 KVE(I,J)=0
DO 31 I=1,15
DO 31 J=1,15
31 KEE(I,J)=0
DO 32 I=1,NV
32 KVE(IP(NI1,I),IS1(2,1,I))=1
I=0
52 I=I+1
IF(I.GT.NV) GO TO 50
NE(1)=IP(NI1,I)
NE(2)=IS1(2,1,I)
IS2(1,1,1)=IP(NI1,I)
IS2(2,1,1)=IS1(2,1,I)
CALL TABLE(IV5,IS2,KW,JJ)
WRITE(7,90) I
DO 95 L=1,2
WRITE(7,91) L
WRITE(7,81) NE(L)
WRITE(7,82) (IS2(L,2,KWW),KWW=1,KW)
WRITE(7,83) (IS2(L,1,KWW),KWW=1,KW)
95 WRITE(7,84) (IV5(L,KWW),KWW=1,KW)
IF(JJ.EQ.0) GO TO 93
WRITE(7,63)
GO TO 50
93 WRITE(7,97)
KW1=0
51 KW1=KW1+1
IF(KW1.GT.KW) GO TO 54
KW2=0
53 KW2=KW2+1
IF(KW2.GT.KW) GO TO 51
IF(KVF(IS2(1,1,KW1),IS2(2,1,KW2)).EQ.0) GO TO 53
KEE(IS2(2,2,KW2),IS2(1,2,KW1))=1
GO TO 51
54 CALL CHECK(MM)
GO TO (52,50,4), MM
4 IF(NI.EQ.1) GO TO 5
WRITE(7,38) NI1,NI
GO TO 300
5 WRITE(7,39) NI1,NI
300 WRITE(7,152)
WRITE(7,190) (IW(I),I=1,NV)
DO 150 I=1,NV
150 WRITE(7,105) I,(KVE(I,J),J=1,NV)
WRITE(7,156)
WRITE(7,190) (IW(I),I=1,KE)
DO 154 I=1,KE
154 WRITE(7,105) I,(KEE(I,J),J=1,KE)
350 CONTINUE
STOP
END
SUBROUTINE ORDER (K,IS,N,ID,JJ)
COMMON IVE(2,10,15),KEE(15,15),IA(2,10,10),KVE(10,10),
IIB(2,15,2),IC(2,10),IV(2,10),IT(10),NV,KE
DIMENSION K(2,N),IS(2,2,N)
M=N-1
DO 8 IG=1,2

```

```

DO 8 J=1,M
L=N-J+1
DO 8 I=2,L
IF(K(IG,I)-K(IG,I-1)) 3,8,8
3 IMAX=K(IG,I-1)
K(IG,I-1)=K(IG,I)
K(IG,I)=IMAX
DO 9 IJ=1, ID
IMAX=IS(IG,IJ,I-1)
IS(IG,IJ,I-1)=IS(IG,IJ,I)
IS(IG,IJ,I)=IMAX
9 CONTINUE
8 CONTINUE
JJ=0
KC=0
10 KC=KC+1
IF(KC.GT.N) RETURN
IF(K(1,KC).EQ.K(2,KC)) GO TO 10
JJ=1
RETURN
END
SUBROUTINE TABLE(IV1,IS1,KW,JJ)
COMMON IVE(2,10,15),KEE(15,15),IA(2,10,10),KVE(10,10),
1IB(2,15,2),IC(2,10),IV(2,10),IT(10),NV,KE
DIMENSION IV1(2,10),IS1(2,2,10)
DO 122 IG=1,2
KT=IS1(IG,1,1)
KW=IC(IG,KT)
DO 122 I=1,KW
KY=IA(IC,KT,I)
IS1(IG,2,I)=KY
IF(1B(IG,KY,1).EQ.KT) GO TO 124
IS1(IG,1,I)=1B(IG,KY,1)
GO TO 126
124 IS1(IG,1,I)=1B(IG,KY,2)
126 MN=IS1(IG,1,I)
IV1(IG,I)=IV(IG,MN)
122 CONTINUE
CALL ORDER(IV1,IS1,KW,2,JJ)
RETURN
END
SUBROUTINE POSSI(IY,IS1,IP,NI)
COMMON IVE(2,10,15),KEE(15,15),IA(2,10,10),KVE(10,10),
1IB(2,15,2),IC(2,10),IV(2,10),IT(10),NV,KE
DIMENSION IN(10),IR(5,24),IW(50,2),IQ(50,10),IS1(2,2,10),
1LV(5,5),IVA(5,24,5),IY(2,10),IP(40,10),KL(10)
K=0
KCO=0
13 I=0
K=K+1
KL(K)=1
11 KCO=KCO+1
I=I+1
IF(KCO.GE.NV) GO TO 15
IF(IY(1,KCO).NE.IY(1,KCO+1)) GO TO 13
KL(K)=I+1
GO TO 11
15 KK=0
DO 21 I=1,K

```



```

KI=KL(I)
DO 21 J1=1,K1
KK=KK+1
LV(I,J1)=IS1(1,1,KK)
21 CONTINUE
DO 19 IK=1,K
KI=KL(IK)
IF(K1.GT.1) GO TO 17
IVA(IK,1,1)=LV(IK,1)
GO TO 19
17 KT=I-T(K1)
CALL PERMU(K1,IP)
DO 20 J=1,KT
DO 20 J1=1,K1
IVA(IK,J,J1)=LV(IK,IP(J,J1))
20 CONTINUE
19 CONTINUE
DO 2 I=1,K
2 IN(I)=I-T(KL(I))
KCO=0
DO 3 IK=1,K
I=IN(IK)
DO 3 J=1,I
KCO=KCO+1
IR(IK,J)=KCO
IW(KCO,1)=IK
IW(KCO,2)=J
3 CONTINUE
NR=1
K1=K-1
IF(K1.LT.2) GO TO 32
DO 4 I=2,K1
4 NR=NR*IN(I)
M1=NR
MT=IN(1)*IN(K1)
DO 6 I1=2,K1
M1=M1/IN(I1)
MC=NR/(M1*IN(I1))
NI=0
DO 6 I5=1,MT
DO 6 I2=1,MC
MN=IN(I1)
DO 6 I3=1,MN
DO 6 I4=1,M1
NI=NI+1
IQ(NI,I1)=IR(I1,I3)
6 CONTINUE
32 NI=0
N1=IN(1)
NK=IN(K)
DO 8 I1=1,N1
DO 8 I2=1,NK
DO 8 I3=1,NR
NI=NI+1
IQ(NI,K)=IR(K,I2)
IQ(NI,1)=IR(1,I1)
8 CONTINUE
DO 50 I1=1,NI
N2=0

```

```

DO 50 I2=1,K
K1=KL(I2)
DO 50 J1=1,K1
N2=N2+1
IK=IW(IQ(I1,I2),1)
J=IW(IQ(I1,I2),2)
IP(I1,N2)=IVA(IK,J,J1)
50 CONTINUE
RETURN
END
SUBROUTINE PERMU(J, IP)
COMMON IVE(2,10,15),KEE(15,15),IA(2,10,10),KVE(10,10),
IIB(2,15,2),IC(2,10),IV(2,10),IT(10),NV,KE
DIMENSION IP(40,10)
IP(1,1)=1
IP(1,2)=2
IP(2,1)=2
IP(2,2)=1
IF(J.EQ.2) RETURN
K=3
22 K1=K-1
KT=IT(K1)
DO 10 I1=1,KT
10 IP(I1,K)=K
KC=KT
DO 20 I5=1,K1
I2=K1-I5+1
DO 20 I4=1,KT
KC=KC+1
IP(KC,K)=I2
KM=1
25 IF(IP(I4,KM).NE.I2) GO TO 17
IP(KC,KM)=K
GO TO 23
17 IP(KC,KM)=IP(I4,KM)
23 KM=KM+1
IF(KM.GT.K1) GO TO 20
GO TO 25
20 CONTINUE
K=K+1
IF(K.LE.J) GO TO 22
RETURN
END
SUBROUTINE CHECK(MM)
COMMON IVE(2,10,15),KEE(15,15),IA(2,10,10),KVE(10,10),
IIB(2,15,2),IC(2,10),IV(2,10),IT(10),NV,KE
DIMENSION M1(10,15),M2(10,15)
MM=1
LC=0
24 LC=LC+1
IF(LC.GT.KE) GO TO 26
LR=0
ISUM=0
22 LR=LR+1
IF(LR.GT.KE) GO TO 20
ISUM=ISUM+KEE(LR,LC)
GO TO 22
20 IF(ISUM.EQ.0) RETURN
GO TO 24

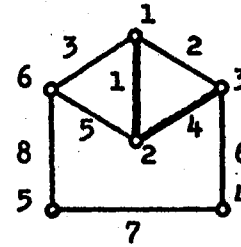
```

```
26 LC=0
66 LC=LC+1
   IF(LC.GT.KE) GO TO 68
   LR=0
62 LR=LR+1
   IF(LR.GT.KE) GO TO 66
   IF(KEE(LR,LC).EQ.0) GO TO 62
   DO 64 I=1,NV
64 M1(I,LC)=IVE(2,I,LR)
   GO TO 66
68 LC=0
61 LC=LC+1
   IF(LC.GT.NV) GO TO 67
   LR=0
63 LR=LR+1
   IF(LR.GT.NV) GO TO 61
   IF(KVE(LR,LC).EQ.0) GO TO 63
   DO 65 I=1,KE
65 M2(LR,I)=M1(LC,I)
   GO TO 61
67 LR=0
52 LR=LR+1
   IF(LR.GT.NV) GO TO 56
   LC=0
54 LC=LC+1
   IF(LC.GT.KE) GO TO 52
   IF(IVF(1,LR,LC).EQ.M2(LR,LC)) GO TO 54
   MM=2
   RETURN
56 MM=3
   RETURN
   END
```

\* EXAMPLE 1 \*

GRAPH 1 VERTEX-VERTEX INCIDENCE MATRIX

	1.	2.	3.	4.	5.	6.
1.	0	10	1	0	0	1
2.	10	0	10	0	0	1
3.	1	10	0	1	0	0
4.	0	0	1	0	1	0
5.	0	0	0	1	0	1
6.	1	1	0	0	1	0

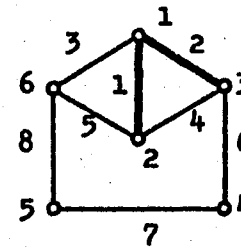


GRAPH 1 VERTEX-EDGE INCIDENCE MATRIX

	1.	2.	3.	4.	5.	6.	7.	8.
1.	10	1	1	0	0	0	0	0
2.	10	0	0	10	1	0	0	0
3.	0	1	0	10	0	1	0	0
4.	0	0	0	0	0	1	1	0
5.	0	0	0	0	0	0	1	1
6.	0	0	1	0	1	0	0	1

GRAPH 2 VERTEX-VERTEX INCIDENCE MATRIX

	1.	2.	3.	4.	5.	6.
1.	0	10	10	0	0	1
2.	10	0	1	0	0	1
3.	10	1	0	1	0	0
4.	0	0	1	0	1	0
5.	0	0	0	1	0	1
6.	1	1	0	0	1	0



GRAPH 2 VERTEX-EDGE INCIDENCE MATRIX

	1.	2.	3.	4.	5.	6.	7.	8.
1.	10	10	1	0	0	0	0	0
2.	10	0	0	1	1	0	0	0
3.	0	10	0	1	0	1	0	0
4.	0	0	0	0	0	1	1	0
5.	0	0	0	0	0	0	1	1
6.	0	0	1	0	1	0	0	1

GRAPH 1	DEGREE OF VERTEX	102	102	103	112	112	121
	VERTEX NUMBER	4	5	6	1	3	2

GRAPH 2	DEGREE OF VERTEX	102	102	103	112	112	121
	VERTEX NUMBER	4	5	6	2	3	1

THE NUMBER OF ARRANGEMENTS OF VERTICES IN GRAPH 1 IS 4 :

DEGREE OF VERTEX...	102	102	103	112	112	121
POSSIBILITY 1...	4	5	6	1	3	2
POSSIBILITY 2...	4	5	6	3	1	2
POSSIBILITY 3...	5	4	6	1	3	2
POSSIBILITY 4...	5	4	6	3	1	2

## POSSIBILITY 1 :

## ( 1 ) INCIDENCE TABLE

GRAPH 1 :			
LEADING VERTEX :	4		
EDGE NUMBER :	7	6	
VERTEX NUMBER :	5	3	
DEGREE OF VERTEX :	102	112	

GRAPH 2 :			
LEADING VERTEX :	4		
EDGE NUMBER :	7	6	
VERTEX NUMBER :	5	3	
DEGREE OF VERTEX :	102	112	

THE DEGREES OF VERTICES IN TWO GRAPHS ARE SAME

## ( 2 ) INCIDENCE TABLE

GRAPH 1 :			
LEADING VERTEX :	5		
EDGE NUMBER :	7	8	
VERTEX NUMBER :	4	6	
DEGREE OF VERTEX :	102	103	

GRAPH 2 :			
LEADING VERTEX :	5		
EDGE NUMBER :	7	8	
VERTEX NUMBER :	4	6	
DEGREE OF VERTEX :	102	103	

THE DEGREES OF VERTICES IN TWO GRAPHS ARE SAME

## ( 3 ) INCIDENCE TABLE

GRAPH 1 :			
LEADING VERTEX :	6		
EDGE NUMBER :	8	3	5
VERTEX NUMBER :	5	1	2
DEGREE OF VERTEX :	102	112	121

GRAPH 2 :			
LEADING VERTEX :	6		
EDGE NUMBER :	8	5	3
VERTEX NUMBER :	5	2	1
DEGREE OF VERTEX :	102	112	121

THE DEGREES OF VERTICES IN TWO GRAPHS ARE SAME

## ( 4 ) INCIDENCE TABLE

GRAPH 1 :			
LEADING VERTEX :	1		
EDGE NUMBER :	3	2	1
VERTEX NUMBER :	6	3	2
DEGREE OF VERTEX :	103	112	121

GRAPH 2 :  
 LEADING VERTEX : 2  
 EDGE NUMBER : 5 4 1  
 VERTEX NUMBER : 6 3 1  
 DEGREE OF VERTEX : 103 112 121

THE DEGREES OF VERTICES IN TWO GRAPHS ARE SAME

( 5 ) INCIDENCE TABLE

GRAPH 1 :  
 LEADING VERTEX : 3  
 EDGE NUMBER : 6 2 4  
 VERTEX NUMBER : 4 1 2  
 DEGREE OF VERTEX : 102 112 121

GRAPH 2 :  
 LEADING VERTEX : 3  
 EDGE NUMBER : 6 4 2  
 VERTEX NUMBER : 4 2 1  
 DEGREE OF VERTEX : 102 112 121

THE DEGREES OF VERTICES IN TWO GRAPHS ARE SAME

TWO GRAPHS ARE ISOMORPHIC  
 ISOMORPHISM IS FOUND AT POSSIBILITY 1 OUT OF TOTAL 4 POSSIBILITIES

VERTEX ELEMENTARY MATRIX

	1.	2.	3.	4.	5.	6.
1.	0	1	0	0	0	0
2.	1	0	0	0	0	0
3.	0	0	1	0	0	0
4.	0	0	0	1	0	0
5.	0	0	0	0	1	0
6.	0	0	0	0	0	1

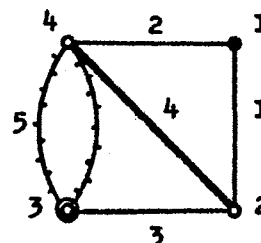
EDGE ELEMENTARY MATRIX

	1.	2.	3.	4.	5.	6.	7.	8.
1.	1	0	0	0	0	0	0	0
2.	0	0	0	1	0	0	0	0
3.	0	0	0	0	1	0	0	0
4.	0	1	0	0	0	0	0	0
5.	0	0	1	0	0	0	0	0
6.	0	0	0	0	0	1	0	0
7.	0	0	0	0	0	0	1	0
8.	0	0	0	0	0	0	0	1

\* EXAMPLE 2 \*

GRAPH 1 VERTEX-VERTEX INCIDENCE MATRIX

	1.	2.	3.	4.
1.	0	1	0	1
2.	1	0	1	10
3.	0	1	0	200
4.	1	10	200	0

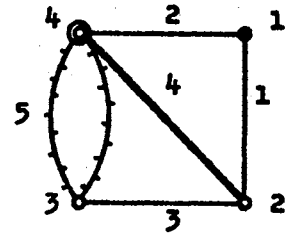


GRAPH 1 VERTEX-EDGE INCIDENCE MATRIX

	1.	2.	3.	4.	5.
1.	1	1	0	0	0
2.	1	0	1	10	0
3.	0	0	1	0	200
4.	0	1	0	10	200

GRAPH 2 VERTEX-VERTEX INCIDENCE MATRIX

	1.	2.	3.	4.
1.	0	1	0	1
2.	1	0	1	10
3.	0	1	0	200
4.	1	10	200	0



GRAPH 2 VERTEX-EDGE INCIDENCE MATRIX

	1.	2.	3.	4.	5.
1.	1	1	0	0	0
2.	1	0	1	10	0
3.	0	0	1	0	200
4.	0	1	0	10	200

GRAPH 1	DEGREE OF VERTEX	1012	2002	1211	4201
	VERTEX NUMBER	2	1	4	3

GRAPH 2	DEGREE OF VERTEX	1012	2002	1201	4211
	VERTEX NUMBER	2	1	3	4

THE DEGREES OF VERTICES IN TWO GRAPHS ARE DIFFERENT  
 THE TWO GRAPHS ARE NOT ISOMORPHIC

## APPENDIX C

### LISTING OF PRISM KINEMATIC CHAINS

The basic kinematic graph of prism kinematic chain ( $P_r$ KC) is similar to that of parent kinematic chain. The prism pair in  $P_r$ KC is represented by another type of fine edge, say fine dash edge (see Chapter VI) in the kinematic graph. The number of prism pairs in kinematic chain is equal to that of fine dash edges in kinematic graph.

Based on the 16 kinematic graphs of parent kinematic chains shown in Appendix A, the kinematic graphs of  $P_r$ KC's are listed with only the fine dash edge numbers shown in the listing. For example, there are 24  $P_r$ KC's with three prism pairs with configuration of #1 parent kinematic graph as shown in Appendix A. The 24 numbers right after the heading "#1 = 24:" are the corresponding numbers shown at the end. 2 is corresponding to 000124, where 124 are the fine dash edge numbers 1, 2 and 4 in the #1 parent kinematic graph.



TOTAL NO. OF KINEMATIC CHAINS WITH 1 UP TO 6 PRISM PAIRS = 3309  
 (1) NUMBER OF KINEMATIC CHAINS WITH 1 PRISM PAIR = 88

# 1= 3:	1	2	7																	
# 2= 3:	1	2	7																	
# 3= 8:	1	2	3	4	5	6	7	10												
# 4= 8:	1	2	5	6	7	8	9	10												
# 5= 4:	1	2	3	4																
# 6= 5:	1	2	3	4	9															
# 7= 10:	1	2	3	4	5	6	7	8	9	10										
# 8= 3:	1	2	3																	
# 9= 6:	1	2	5	7	9	10														
#10= 6:	1	2	4	5	8	10														
#11= 5:	1	5	6	7	9															
#12= 6:	1	2	4	5	6	10														
#13= 10:	1	2	3	4	5	6	7	8	9	10										
#14= 3:	1	2	7																	
#15= 4:	1	2	5	9																
#16= 4:	1	2	3	6																

1.	0	0	0	0	0	1	2.	0	0	0	0	0	2	3.	0	0	0	0	0	3
4.	0	0	0	0	0	4	5.	0	0	0	0	0	5	6.	0	0	0	0	0	6
7.	0	0	0	0	0	7	8.	0	0	0	0	0	8	9.	0	0	0	0	0	9
10.	0	0	0	0	0	10														

(2) NUMBER OF KINEMATIC CHAINS WITH 2 PRISM PAIRS = 350

# 1= 12:	1	2	3	4	5	6	7	12	14	40	41	42								
# 2= 8:	1	2	3	4	5	9	12	17												
# 3= 30:	1	2	3	4	5	6	9	10	11	12	13	14	17	18	19	20	21			
24 25	26	27	30	31	32	35	36	37	38	39	42									
# 4= 31:	1	2	3	4	5	6	7	8	9	10	12	13	14	15	16	17	31			
32 33	34	35	36	37	38	39	40	41	42	43	44	45								
# 5= 12:	1	2	3	4	5	6	7	10	11	12	15	18								
# 6= 25:	1	2	3	4	5	6	7	8	9	10	11	12	13	14	16	17	18			
19 20	23	24	25	29	30	45														
# 7= 45:	1	2	3	4	5	6	7	8	9	10	11	12	13	14	15	16	17			
18 19	20	21	22	23	24	25	26	27	28	29	30	31	32	33	34	35	36			
37 38	39	40	41	42	43	44	45													
# 8= 8:	1	2	3	4	5	6	7	20												
# 9= 23:	1	2	3	4	5	6	7	8	9	10	12	13	14	15	16	17	33			
34 35	40	41	42	45																
#10= 25:	1	2	3	4	5	6	7	8	9	11	12	15	17	25	26	27	28			
29 30	31	33	34	35	43	44														
#11= 18:	1	2	3	4	5	6	7	8	9	31	32	33	34	35	36	37	38			
41																				
#12= 25:	1	2	3	4	5	6	7	8	9	11	12	13	17	25	26	27	28			
29 30	31	33	34	35	38	39														
#13= 45:	1	2	3	4	5	6	7	8	9	10	11	12	13	14	15	16	17			
18 19	20	21	22	23	24	25	26	27	28	29	30	31	32	33	34	35	36			
37 38	39	40	41	42	43	44	45													
#14= 12:	1	2	3	4	6	8	11	12	14	40	41	42								
#15= 16:	1	2	3	4	5	6	7	8	9	11	13	16	17	28	29	45				
#16= 15:	1	2	3	4	5	6	7	8	9	10	11	13	15	17	20					

1.	0	0	0	0	1	2	2.	0	0	0	0	1	3	3.	0	0	0	0	1	4
4.	0	0	0	0	1	5	5.	0	0	0	0	1	6	6.	0	0	0	0	1	7
7.	0	0	0	0	1	8	8.	0	0	0	0	1	9	9.	0	0	0	0	1	10
10.	0	0	0	0	2	3	11.	0	0	0	0	2	4	12.	0	0	0	0	2	5
13.	0	0	0	0	2	6	14.	0	0	0	0	2	7	15.	0	0	0	0	2	8

16.	0	0	0	0	2	9	17.	0	0	0	0	2	10	18.	0	0	0	0	3	4
19.	0	0	0	0	3	5	20.	0	0	0	0	3	6	21.	0	0	0	0	3	7
22.	0	0	0	0	3	8	23.	0	0	0	0	3	9	24.	0	0	0	0	3	10
25.	0	0	0	0	4	5	26.	0	0	0	0	4	6	27.	0	0	0	0	4	7
28.	0	0	0	0	4	8	29.	0	0	0	0	4	9	30.	0	0	0	0	4	10
31.	0	0	0	0	5	6	32.	0	0	0	0	5	7	33.	0	0	0	0	5	8
34.	0	0	0	0	5	9	35.	0	0	0	0	5	10	36.	0	0	0	0	6	7
37.	0	0	0	0	6	8	38.	0	0	0	0	6	9	39.	0	0	0	0	6	10
40.	0	0	0	0	7	8	41.	0	0	0	0	7	9	42.	0	0	0	0	7	10
43.	0	0	0	0	8	9	44.	0	0	0	0	8	10	45.	0	0	0	0	9	10

(3) NUMBER OF KINEMATIC CHAINS WITH 3 PRISM PAIRS = 810

# 1= 24:	2	3	4	5	6	9	10	12	13	16	18	19	23	24	27	28	31
32 33 34	51	59	60	61	9	10	19	21	23	24	26	27	30	52	54		
# 2= 14:	2	3	4	9	10	19	21	23	24	26	27	30	52	54			
# 3= 70:	2	3	4	5	9	10	11	12	16	17	18	21	22	23	26	27	28
29 30 32 33	37	38	39	40	44	45	46	49	50	51	54	55	56	57	58		
60 61 65 66	67	70	71	72	75	76	77	78	79	81	82	86	87	90	91		
92 93 94 96	97	101	102	103	104	106	107	113	115	116	119						
# 4= 73:	3	4	5	6	7	8	10	11	12	13	15	16	17	18	19	20	21
22 23 24 25	26	27	28	29	30	31	32	33	34	35	36	38	39	40	41		
42 43 50 51	52	53	54	55	56	57	58	59	60	61	62	63	64	101	102		
103 104 105 106	107	108	109	110	111	112	113	114	115	116	117	118	119	14			
# 5= 22:	1	2	3	9	10	11	12	13	16	18	23	24	25	26	27	37	38
41 47 52 4	19																
# 6= 57:	2	3	4	5	6	7	9	10	11	12	13	14	15	16	17	18	19
20 21 22 23	25	26	27	29	30	32	33	34	36	37	38	39	40	42	44		
45 46 48 49	50	53	54	57	58	60	64	65	66	69	70	74	75	78	85		
89 100																	
# 7=111:	2	3	4	5	6	7	9	10	11	12	13	14	16	17	18	19	20
21 22 23 24	25	26	27	28	29	30	31	32	33	34	35	36	37	38	39		
40 41 42 44	45	46	47	48	49	50	51	52	53	54	55	56	57	58	59		
60 61 62 63	64	65	66	67	68	69	70	71	72	73	74	75	76	77	78		
79 80 81 82	83	84	85	86	87	88	89	90	91	92	93	94	95	96	97		
102 103 104 105	106	107	108	109	110	111	112	113	114	115	116	117	118	119			
# 8= 12:	1	2	9	10	11	12	13	18	19	22	23	27					
# 9= 62:	119	1	2	3	4	5	6	7	8	10	11	12	13	14	15	16	18
20 21 22 23	24	25	26	27	28	29	30	31	32	33	34	35	36	38	40		
42 43 50 51	52	53	54	55	56	57	58	59	60	61	62	63	64	103	104		
106 107 108 109	110	117	118														
#10= 59:	2	3	4	5	6	7	8	9	10	13	15	16	17	18	19	20	21
22 23 24 25	26	27	28	29	30	31	32	33	34	35	36	44	45	46	47		
48 49 50 52	53	54	62	63	86	87	88	92	93	94	95	97	98	99	102		
104 108 109 120																	
#11= 39:	3	4	5	7	10	11	12	14	16	17	18	19	20	108	110	112	21
22 23 24 25	26	27	28	29	30	31	32	33	34	35	36	101	102	103	104		
105 106 107																	
#12= 58:	2	3	4	5	6	7	8	9	10	11	15	16	17	18	19	20	21
22 23 24 25	26	27	28	29	30	31	32	33	34	35	36	44	45	46	47		
48 49 50 52	53	54	57	58	86	87	88	91	92	93	94	97	98	99	102		
103 109 116																	
#13=115:	2	3	4	5	6	7	8	9	10	11	12	13	14	15	16	17	20
21 22 23 24	25	26	27	28	29	30	31	32	33	34	35	36	37	38	39		
40 41 42 43	44	45	46	47	48	49	50	51	52	53	54	55	56	57	58		
59 60 61 62	63	64	65	66	67	68	69	70	71	72	73	74	75	76	77		
78 79 80 81	82	83	84	85	88	90	92	94	95	96	98	99	100	102	103		
104 106 107 108	110	111	112	113	114	115	116	117	118	119	120	18	19	89	93		
97 105 109																	
#14= 27:	2	3	5	7	9	10	12	16	17	18	19	20	21	23	25	31	32

	33	36	44	45	46	47	51	59	60	61									
#15= 31:	2	3	4	5	6	8	9	10	11	12	15	17	18	19	20	21	25		
28	29	30	31	32	34	35	36	45	47	48	49	57	64						
#16= 36:	1	2	3	4	5	6	7	8	9	10	11	12	13	14	15	17	18		
19	20	21	22	23	24	27	28	29	30	35	37	39	41	43	45	47	56	58	

1.	0	0	0	1	2	3				2.	0	0	0	1	2	4				3.	0	0	0	1	2	5
4.	0	0	0	1	2	6				5.	0	0	0	1	2	7				6.	0	0	0	1	2	8
7.	0	0	0	1	2	9				8.	0	0	0	1	2	10				9.	0	0	0	1	3	4
10.	0	0	0	1	3	5				11.	0	0	0	1	3	6				12.	0	0	0	1	3	7
13.	0	0	0	1	3	8				14.	0	0	0	1	3	9				15.	0	0	0	1	3	10
16.	0	0	0	1	4	5				17.	0	0	0	1	4	6				18.	0	0	0	1	4	7
19.	0	0	0	1	4	8				20.	0	0	0	1	4	9				21.	0	0	0	1	4	10
22.	0	0	0	1	5	6				23.	0	0	0	1	5	7				24.	0	0	0	1	5	8
25.	0	0	0	1	5	9				26.	0	0	0	1	5	10				27.	0	0	0	1	6	7
28.	0	0	0	1	6	8				29.	0	0	0	1	6	9				30.	0	0	0	1	6	10
31.	0	0	0	1	7	8				32.	0	0	0	1	7	9				33.	0	0	0	1	7	10
34.	0	0	0	1	8	9				35.	0	0	0	1	8	10				36.	0	0	0	1	9	10
37.	0	0	0	2	3	4				38.	0	0	0	2	3	5				39.	0	0	0	2	3	6
40.	0	0	0	2	3	7				41.	0	0	0	2	3	8				42.	0	0	0	2	3	9
43.	0	0	0	2	3	10				44.	0	0	0	2	4	5				45.	0	0	0	2	4	6
46.	0	0	0	2	4	7				47.	0	0	0	2	4	8				48.	0	0	0	2	4	9
49.	0	0	0	2	4	10				50.	0	0	0	2	5	6				51.	0	0	0	2	5	7
52.	0	0	0	2	5	8				53.	0	0	0	2	5	9				54.	0	0	0	2	5	10
55.	0	0	0	2	6	7				56.	0	0	0	2	6	8				57.	0	0	0	2	6	9
58.	0	0	0	2	6	10				59.	0	0	0	2	7	8				60.	0	0	0	2	7	9
61.	0	0	0	2	7	10				62.	0	0	0	2	8	9				63.	0	0	0	2	8	10
64.	0	0	0	2	9	10				65.	0	0	0	3	4	5				66.	0	0	0	3	4	6
67.	0	0	0	3	4	7				68.	0	0	0	3	4	8				69.	0	0	0	3	4	9
70.	0	0	0	3	4	10				71.	0	0	0	3	5	6				72.	0	0	0	3	5	7
73.	0	0	0	3	5	8				74.	0	0	0	3	5	9				75.	0	0	0	3	5	10
76.	0	0	0	3	6	7				77.	0	0	0	3	6	8				78.	0	0	0	3	6	9
79.	0	0	0	3	6	10				80.	0	0	0	3	7	8				81.	0	0	0	3	7	9
82.	0	0	0	3	7	10				83.	0	0	0	3	8	9				84.	0	0	0	3	8	10
85.	0	0	0	3	9	10				86.	0	0	0	4	5	6				87.	0	0	0	4	5	7
88.	0	0	0	4	5	8				89.	0	0	0	4	5	9				90.	0	0	0	4	5	10
91.	0	0	0	4	6	7				92.	0	0	0	4	6	8				93.	0	0	0	4	6	9
94.	0	0	0	4	6	10				95.	0	0	0	4	7	8				96.	0	0	0	4	7	9
97.	0	0	0	4	7	10				98.	0	0	0	4	8	9				99.	0	0	0	4	8	10
100.	0	0	0	4	9	10				101.	0	0	0	5	6	7				102.	0	0	0	5	6	8
103.	0	0	0	5	6	9				104.	0	0	0	5	6	10				105.	0	0	0	5	7	8
106.	0	0	0	5	7	9				107.	0	0	0	5	7	10				108.	0	0	0	5	8	9
109.	0	0	0	5	8	10				110.	0	0	0	5	9	10				111.	0	0	0	6	7	8
112.	0	0	0	6	7	9				113.	0	0	0	6	7	10				114.	0	0	0	6	8	9
115.	0	0	0	6	8	10				116.	0	0	0	6	9	10				117.	0	0	0	7	8	9
118.	0	0	0	7	8	10				119.	0	0	0	7	9	10				120.	0	0	0	8	9	10

(4) NUMBER OF KINEMATIC CHAINS WITH 4 PRISM PAIRS = 1157

# 1= 44: 8 9 10 11 14 15 16 19 20 24 25 26 27 30 31 32 35

36 37 45 46 48 53 54 55 56 59 60 60 61 62 65 66 70 71 72

73 75 76 77 78 125 126 127

# 2= 21: 8 9 10 11 12 14 15 16 19 30 31 32 33 37 61 63 64

71 73 77 129

# 3= 98: 8 9 10 14 15 19 20 21 24 29 30 31 35 36 40 41 42

45 50 51 54 55 56 57 58 60 61 65 66 67 68 70 71 77 79 80

83 85 86 87 91 92 96 97 98 101 106 107 110 111 112 113 114 116 117

121 122 123 124 126 127 133 135 136 139 141 142 145 146 147 148 149 151 152

156 157 158 159 161 162 168 170 171 174 177 178 181 190 191 194 196 197 198

200 201 204 207 208

# 4=102: 16 17 18 20 21 22 23 24 25 26 27 28 35 36 37 38 39  
 40 41 42 43 44 45 46 47 48 49 50 51 52 53 54 55 56 57 58  
 59 60 61 62 208 63 64 66 67 68 69 70 71 72 73 74 75 76 77  
 78 79 80 81 82 83 91 92 93 94 95 96 97 98 99 206 100 101 102  
 103 104 105 122 123 124 125 126 127 128 129 130 131 132 133 134 135 136 137  
 138 139 196 197 198 202 203 204 207  
 # 5= 34: 1 2 3 8 9 14 17 18 21 29 30 31 32 36 37 38 39  
 40 41 42 51 52 54 55 70 71 72 73 76 85 88 93 95 129  
 # 6= 74: 8 9 10 11 12 14 15 16 17 19 20 21 22 23 24 26 29  
 30 31 32 33 35 36 37 38 40 41 42 45 47 50 51 52 55 57 58  
 60 61 62 63 65 67 68 70 71 77 80 83 84 85 86 87 89 91 92  
 94 96 98 101 106 107 109 113 114 116 117 123 124 136 139 141 148 149 171  
 # 7=150: 8 9 10 11 12 14 15 16 17 19 20 21 23 24 26 29 30  
 31 32 33 35 36 37 38 40 41 42 44 45 47 50 51 52 53 54 55  
 56 57 58 59 60 61 66 67 68 69 70 71 72 73 74 75 76 77 78  
 79 80 81 82 83 85 86 87 88 89 91 92 93 94 96 97 98 100 101  
 103 106 107 108 109 110 111 112 113 114 115 116 117 118 119 120 122 123 124  
 125 126 127 128 129 130 131 132 133 134 135 136 137 138 139 141 142 143 144  
 145 146 147 148 149 150 151 152 157 158 159 160 161 162 163 164 165 166 167  
 168 169 170 171 172 173 174 177 178 180 181 186 187 200 201 203 204 207 208  
 # 8= 21: 1 2 3 4 8 12 13 30 31 32 33 34 35 36 37 40 41  
 60 61 63 71  
 # 9= 92: 1 2 3 4 5 6 7 8 9 10 11 12 13 14 15 16 17  
 18 19 20 21 22 23 26 27 35 36 37 38 39 40 41 42 43 44 45  
 46 47 48 49 50 51 52 53 54 59 60 61 67 68 70 71 72 73 74  
 76 77 78 79 80 81 82 84 91 92 93 94 95 100 101 102 123 124 126  
 127 128 129 130 132 133 134 135 136 137 138 140 201 204 205 210 64 105  
 #10= 81: 8 9 10 11 12 13 14 15 16 17 18 19 20 21 22 23 24  
 25 26 27 28 29 30 31 32 33 34 35 37 38 39 48 50 51 52 55  
 56 57 58 59 60 61 62 63 64 65 66 67 68 70 71 72 73 76 78  
 80 81 83 84 106 107 108 112 113 114 115 117 118 119 122 124 128 129 140  
 176 177 180 189 192 199 69  
 #11= 50: 14 15 16 19 20 21 24 35 36 37 38 39 40 41 42 45 50  
 51 52 53 54 55 56 57 58 59 60 61 62 63 64 65 66 67 68 69  
 70 71 72 73 77 79 80 82 84 198 200 201 204 83  
 #12= 83: 8 9 10 11 12 13 14 15 16 17 18 19 20 21 22 23 24  
 25 26 27 28 29 30 31 32 33 34 35 37 38 39 42 43 50 51 52  
 55 56 57 58 59 60 61 62 63 64 65 66 67 68 69 70 71 72 73  
 76 78 80 81 83 84 106 107 108 111 112 113 114 117 118 119 120 122 123  
 124 129 136 176 177 180 187 189 199  
 #13=165: 8 9 10 11 12 13 14 15 16 17 18 19 20 21 22 23 24  
 26 27 28 29 30 31 32 33 34 35 36 37 38 39 40 41 42 43 44  
 45 48 47 49 52 53 54 56 57 58 59 60 61 62 63 64 66 67 68  
 69 70 71 72 73 74 75 76 77 78 79 80 81 82 83 84 85 89 86  
 87 88 90 91 92 93 94 95 96 97 98 99 100 101 103 104 105 108 109  
 110 112 113 114 115 116 117 118 119 120 172 122 123 124 125 126 127 128 129  
 130 131 132 133 134 135 136 137 138 139 140 143 145 147 149 150 151 153 154  
 155 157 158 159 160 161 162 163 165 166 167 169 170 171 173 174 175 183 184  
 185 189 190 191 202 203 204 206 207 208 144 148 152 164 168  
 #14= 47: 8 9 10 11 12 13 15 17 23 24 25 28 29 30 31 32 44  
 45 51 52 53 54 55 57 59 60 61 62 63 64 69 70 71 74 107 108  
 111 115 116 117 118 121 122 125 126 127 36  
 #15= 41: 8 9 10 11 13 14 15 16 18 19 20 22 23 25 27 29 30  
 31 32 34 36 39 43 52 53 54 56 57 58 59 60 61 74 78 79 80  
 81 83 112 113 119  
 #16= 54: 3 4 5 6 7 9 10 11 12 13 14 15 16 17 18 21 22  
 24 25 26 27 28 30 31 32 33 34 35 36 37 40 41 42 43 48 55  
 56 57 58 60 61 62 63 64 65 66 70 73 86 88 97 99 112 119

1.	0	0	1	2	3	4	2.	0	0	1	2	3	5	3.	0	0	1	2	3	6
4.	0	0	1	2	3	7	5.	0	0	1	2	3	8	6.	0	0	1	2	3	9
7.	0	0	1	2	3	10	8.	0	0	1	2	4	5	9.	0	0	1	2	4	6
10.	0	0	1	2	4	7	11.	0	0	1	2	4	8	12.	0	0	1	2	4	9
13.	0	0	1	2	4	10	14.	0	0	1	2	5	6	15.	0	0	1	2	5	7
16.	0	0	1	2	5	8	17.	0	0	1	2	5	9	18.	0	0	1	2	5	10
19.	0	0	1	2	6	7	20.	0	0	1	2	6	8	21.	0	0	1	2	6	9
22.	0	0	1	2	6	10	23.	0	0	1	2	7	8	24.	0	0	1	2	7	9
25.	0	0	1	2	7	10	26.	0	0	1	2	8	9	27.	0	0	1	2	8	10
28.	0	0	1	2	9	10	29.	0	0	1	3	4	5	30.	0	0	1	3	4	6
31.	0	0	1	3	4	7	32.	0	0	1	3	4	8	33.	0	0	1	3	4	9
34.	0	0	1	3	4	10	35.	0	0	1	3	5	6	36.	0	0	1	3	5	7
37.	0	0	1	3	5	8	38.	0	0	1	3	5	9	39.	0	0	1	3	5	10
40.	0	0	1	3	6	7	41.	0	0	1	3	6	8	42.	0	0	1	3	6	9
43.	0	0	1	3	6	10	44.	0	0	1	3	7	8	45.	0	0	1	3	7	9
46.	0	0	1	3	7	10	47.	0	0	1	3	8	9	48.	0	0	1	3	8	10
49.	0	0	1	3	9	10	50.	0	0	1	4	5	6	51.	0	0	1	4	5	7
52.	0	0	1	4	5	8	53.	0	0	1	4	5	9	54.	0	0	1	4	5	10
55.	0	0	1	4	6	7	56.	0	0	1	4	6	8	57.	0	0	1	4	6	9
58.	0	0	1	4	6	10	59.	0	0	1	4	7	8	60.	0	0	1	4	7	9
61.	0	0	1	4	7	10	62.	0	0	1	4	8	9	63.	0	0	1	4	8	10
64.	0	0	1	4	9	10	65.	0	0	1	5	6	7	66.	0	0	1	5	6	8
67.	0	0	1	5	6	9	68.	0	0	1	5	6	10	69.	0	0	1	5	7	8
70.	0	0	1	5	7	9	71.	0	0	1	5	7	10	72.	0	0	1	5	8	9
73.	0	0	1	5	8	10	74.	0	0	1	5	9	10	75.	0	0	1	6	7	8
76.	0	0	1	6	7	9	77.	0	0	1	6	7	10	78.	0	0	1	6	8	9
79.	0	0	1	6	8	10	80.	0	0	1	6	9	10	81.	0	0	1	7	8	9
82.	0	0	1	7	8	10	83.	0	0	1	7	9	10	84.	0	0	1	8	9	10
85.	0	0	2	3	4	5	86.	0	0	2	3	4	6	87.	0	0	2	3	4	7
88.	0	0	2	3	4	8	89.	0	0	2	3	4	9	90.	0	0	2	3	4	10
91.	0	0	2	3	5	6	92.	0	0	2	3	5	7	93.	0	0	2	3	5	8
94.	0	0	2	3	5	9	95.	0	0	2	3	5	10	96.	0	0	2	3	6	7
97.	0	0	2	3	6	8	98.	0	0	2	3	6	9	99.	0	0	2	3	6	10
100.	0	0	2	3	7	8	101.	0	0	2	3	7	9	102.	0	0	2	3	7	10
103.	0	0	2	3	8	9	104.	0	0	2	3	8	10	105.	0	0	2	3	9	10
106.	0	0	2	4	5	6	107.	0	0	2	4	5	7	108.	0	0	2	4	5	8
109.	0	0	2	4	5	9	110.	0	0	2	4	5	10	111.	0	0	2	4	6	7
112.	0	0	2	4	6	8	113.	0	0	2	4	6	9	114.	0	0	2	4	6	10
115.	0	0	2	4	7	8	116.	0	0	2	4	7	9	117.	0	0	2	4	7	10
118.	0	0	2	4	8	9	119.	0	0	2	4	8	10	120.	0	0	2	4	9	10
121.	0	0	2	5	6	7	122.	0	0	2	5	6	8	123.	0	0	2	5	6	9
124.	0	0	2	5	6	10	125.	0	0	2	5	7	8	126.	0	0	2	5	7	9
127.	0	0	2	5	7	10	128.	0	0	2	5	8	9	129.	0	0	2	5	8	10
130.	0	0	2	5	9	10	131.	0	0	2	6	7	8	132.	0	0	2	6	7	9
133.	0	0	2	6	7	10	134.	0	0	2	6	8	9	135.	0	0	2	6	8	10
136.	0	0	2	6	9	10	137.	0	0	2	7	8	9	138.	0	0	2	7	8	10
139.	0	0	2	7	9	10	140.	0	0	2	8	9	10	141.	0	0	3	4	5	6
142.	0	0	3	4	5	7	143.	0	0	3	4	5	8	144.	0	0	3	4	5	9
145.	0	0	3	4	5	10	146.	0	0	3	4	6	7	147.	0	0	3	4	6	8
148.	0	0	3	4	6	9	149.	0	0	3	4	6	10	150.	0	0	3	4	7	8
151.	0	0	3	4	7	9	152.	0	0	3	4	7	10	153.	0	0	3	4	8	9
154.	0	0	3	4	8	10	155.	0	0	3	4	9	10	156.	0	0	3	5	6	7
157.	0	0	3	5	6	8	158.	0	0	3	5	6	9	159.	0	0	3	5	6	10
160.	0	0	3	5	7	8	161.	0	0	3	5	7	9	162.	0	0	3	5	7	10
163.	0	0	3	5	8	9	164.	0	0	3	5	8	10	165.	0	0	3	5	9	10
166.	0	0	3	6	7	8	167.	0	0	3	6	7	9	168.	0	0	3	6	7	10
169.	0	0	3	6	8	9	170.	0	0	3	6	8	10	171.	0	0	3	6	9	10
172.	0	0	3	7	8	9	173.	0	0	3	7	8	10	174.	0	0	3	7	9	10
175.	0	0	3	8	9	10	176.	0	0	4	5	6	7	177.	0	0	4	5	6	8

178.	0	0	4	5	6	9	179.	0	0	4	5	6	10	180.	0	0	4	5	7	8
181.	0	0	4	5	7	9	182.	0	0	4	5	7	10	183.	0	0	4	5	8	9
184.	0	0	4	5	8	10	185.	0	0	4	5	9	10	186.	0	0	4	6	7	8
187.	0	0	4	6	7	9	188.	0	0	4	6	7	10	189.	0	0	4	6	8	9
190.	0	0	4	6	8	10	191.	0	0	4	6	9	10	192.	0	0	4	7	8	9
193.	0	0	4	7	8	10	194.	0	0	4	7	9	10	195.	0	0	4	8	9	10
196.	0	0	5	6	7	8	197.	0	0	5	6	7	9	198.	0	0	5	6	7	10
199.	0	0	5	6	8	9	200.	0	0	5	6	8	10	201.	0	0	5	6	9	10
202.	0	0	5	7	8	9	203.	0	0	5	7	8	10	204.	0	0	5	7	9	10
205.	0	0	5	8	9	10	206.	0	0	6	7	8	9	207.	0	0	6	7	8	10
208.	0	0	6	7	9	10	209.	0	0	6	8	9	10	210.	0	0	7	8	9	10

(5) NUMBER OF KINEMATIC CHAINS WITH 5 PRISM PAIRS = 730

# 1= 24:	23	27	28	29	32	33	34	37	38	42	43	44	45	48	49	50	58	
59	62	67	68	69	77	78												
# 2= 10:	24	25	27	28	29	31	37	38	62	63								
# 3= 59:	22	23	27	28	29	32	37	38	39	42	57	58	62	63	64	67	72	
73	74	77	93	94	97	106	107	110	116	117	120	127	128	132	133	134	135	137
138	142	143	144	147	163	164	167	176	177	180	186	187	190	198	199	202	211	212
215	221	222	225															
# 4= 73:	44	45	46	50	51	52	72	73	74	75	76	77	78	79	80	81	82	
83	84	85	86	87	88	89	90	93	94	95	96	97	98	99	100	101	102	103
104	105	106	107	108	109	110	118	119	120	122	123	124	143	144	145	146	147	148
149	150	151	152	153	154	155	156	157	158	159	160	188	189	190	192	193	194	
# 5= 18:	10	11	14	25	26	29	58	59	61	62	63	77	79	80	85	100	129	
150																		
# 6= 34:	27	28	29	31	32	34	37	38	39	42	57	58	59	62	63	64	67	
69	72	74	77	79	92	104	114	127	128	132	134	137	147	22	23	24		
# 7= 92:	22	23	24	25	27	28	29	31	32	38	39	41	42	44	47	48	50	
53	57	58	59	60	62	63	64	66	67	73	74	76	77	79	82	83	85	88
93	94	95	96	97	102	103	116	117	119	120	123	124	127	128	129	130	132	133
134	136	137	143	144	146	147	149	152	153	155	158	163	164	166	167	168	172	186
187	189	190	193	194	198	199	201	202	207	208	221	222	224	225	228	229	173	
# 8= 11:	5	6	11	62	67	68	69	70	72	78	114							
# 9= 69:	5	6	8	9	10	11	12	13	14	15	16	19	20	23	24	25	26	
27	28	29	30	34	35	39	40	44	45	50	51	74	75	77	78	79	80	81
83	84	85	86	87	88	89	94	95	97	98	99	100	101	108	109	110	117	121
122	125	144	145	147	148	149	150	151	158	159	187	191	195					
# 10= 49:	22	23	24	27	28	29	30	31	32	33	35	37	38	39	40	41	42	
43	45	48	49	52	55	57	58	59	63	64	65	66	68	70	75	80	92	93
96	103	105	108	113	115	118	162	163	166	175	178	185						
# 11= 30:	37	38	41	43	72	73	74	75	76	77	78	79	92	93	94	95	96	
97	98	99	100	104	106	107	108	109	110	111	114	116						
# 12= 56:	23	24	27	28	29	30	31	32	33	34	35	37	38	39	40	41	42	
43	44	45	48	50	52	53	55	56	58	59	62	63	64	65	68	69	70	73
74	75	80	87	92	93	96	103	105	108	113	115	116	118	162	163	166	173	175
185																		
# 13= 112:	24	25	26	28	29	30	31	32	35	36	38	39	40	41	42	44	45	
46	47	48	50	51	52	53	56	59	60	61	63	64	65	66	67	70	71	73
74	75	76	77	79	80	81	82	83	85	86	87	88	91	99	100	101	105	106
107	118	119	120	122	123	124	129	130	131	133	134	135	136	137	139	140	141	143
144	145	146	149	150	151	152	153	155	156	157	158	161	169	170	171	175	176	177
188	189	190	192	193	194	204	205	206	210	211	212	223	224	225	227	228	229	147
# 14= 32:	23	24	25	26	27	31	32	34	36	41	42	46	53	58	59	62	66	
67	69	76	77	88	97	98	99	103	104	167	168	169	173	174				
# 15= 20:	22	23	24	26	27	28	30	31	33	41	45	47	51	54	58	59	61	
63	65	68																
# 16= 41:	17	18	19	20	29	30	32	33	34	35	36	39	40	42	43	44	45	
46	62	63	64	65	67	68	69	70	72	73	77	80	86	103	104	105	106	113

116 133 140 156 176

1.	0	1	2	3	4	5	2.	0	1	2	3	4	6	3.	0	1	2	3	4	7
4.	0	1	2	3	4	8	5.	0	1	2	3	4	9	6.	0	1	2	3	4	10
7.	0	1	2	3	5	6	8.	0	1	2	3	5	7	9.	0	1	2	3	5	8
10.	0	1	2	3	5	9	11.	0	1	2	3	5	10	12.	0	1	2	3	6	7
13.	0	1	2	3	6	8	14.	0	1	2	3	6	9	15.	0	1	2	3	6	10
16.	0	1	2	3	7	8	17.	0	1	2	3	7	9	18.	0	1	2	3	7	10
19.	0	1	2	3	8	9	20.	0	1	2	3	8	10	21.	0	1	2	3	9	10
22.	0	1	2	4	5	6	23.	0	1	2	4	5	7	24.	0	1	2	4	5	8
25.	0	1	2	4	5	9	26.	0	1	2	4	5	10	27.	0	1	2	4	6	7
28.	0	1	2	4	6	8	29.	0	1	2	4	6	9	30.	0	1	2	4	6	10
31.	0	1	2	4	7	8	32.	0	1	2	4	7	9	33.	0	1	2	4	7	10
34.	0	1	2	4	8	9	35.	0	1	2	4	8	10	36.	0	1	2	4	9	10
37.	0	1	2	5	6	7	38.	0	1	2	5	6	8	39.	0	1	2	5	6	9
40.	0	1	2	5	6	10	41.	0	1	2	5	7	8	42.	0	1	2	5	7	9
43.	0	1	2	5	7	10	44.	0	1	2	5	8	9	45.	0	1	2	5	8	10
46.	0	1	2	5	9	10	47.	0	1	2	6	7	8	48.	0	1	2	6	7	9
49.	0	1	2	6	7	10	50.	0	1	2	6	8	9	51.	0	1	2	6	8	10
52.	0	1	2	6	9	10	53.	0	1	2	7	8	9	54.	0	1	2	7	8	10
55.	0	1	2	7	9	10	56.	0	1	2	8	9	10	57.	0	1	3	4	5	6
58.	0	1	3	4	5	7	59.	0	1	3	4	5	8	60.	0	1	3	4	5	9
61.	0	1	3	4	5	10	62.	0	1	3	4	6	7	63.	0	1	3	4	6	8
64.	0	1	3	4	6	9	65.	0	1	3	4	6	10	66.	0	1	3	4	7	8
67.	0	1	3	4	7	9	68.	0	1	3	4	7	10	69.	0	1	3	4	8	9
70.	0	1	3	4	8	10	71.	0	1	3	4	9	10	72.	0	1	3	5	6	7
73.	0	1	3	5	6	8	74.	0	1	3	5	6	9	75.	0	1	3	5	6	10
76.	0	1	3	5	7	8	77.	0	1	3	5	7	9	78.	0	1	3	5	7	10
79.	0	1	3	5	8	9	80.	0	1	3	5	8	10	81.	0	1	3	5	9	10
82.	0	1	3	6	7	8	83.	0	1	3	6	7	9	84.	0	1	3	6	7	10
85.	0	1	3	6	8	9	86.	0	1	3	6	8	10	87.	0	1	3	6	9	10
88.	0	1	3	7	8	9	89.	0	1	3	7	8	10	90.	0	1	3	7	9	10
91.	0	1	3	8	9	10	92.	0	1	4	5	6	7	93.	0	1	4	5	6	8
94.	0	1	4	5	6	9	95.	0	1	4	5	6	10	96.	0	1	4	5	7	8
97.	0	1	4	5	7	9	98.	0	1	4	5	7	10	99.	0	1	4	5	8	9
100.	0	1	4	5	8	10	101.	0	1	4	5	9	10	102.	0	1	4	6	7	8
103.	0	1	4	6	7	9	104.	0	1	4	6	7	10	105.	0	1	4	6	8	9
106.	0	1	4	6	8	10	107.	0	1	4	6	9	10	108.	0	1	4	7	8	9
109.	0	1	4	7	8	10	110.	0	1	4	7	9	10	111.	0	1	4	8	9	10
112.	0	1	5	6	7	8	113.	0	1	5	6	7	9	114.	0	1	5	6	7	10
115.	0	1	5	6	8	9	116.	0	1	5	6	8	10	117.	0	1	5	6	9	10
118.	0	1	5	7	8	9	119.	0	1	5	7	8	10	120.	0	1	5	7	9	10
121.	0	1	5	8	9	10	122.	0	1	6	7	8	9	123.	0	1	6	7	8	10
124.	0	1	6	7	9	10	125.	0	1	6	8	9	10	126.	0	1	7	8	9	10
127.	0	2	3	4	5	6	128.	0	2	3	4	5	7	129.	0	2	3	4	5	8
130.	0	2	3	4	5	9	131.	0	2	3	4	5	10	132.	0	2	3	4	6	7
133.	0	2	3	4	6	8	134.	0	2	3	4	6	9	135.	0	2	3	4	6	10
136.	0	2	3	4	7	8	137.	0	2	3	4	7	9	138.	0	2	3	4	7	10
139.	0	2	3	4	8	9	140.	0	2	3	4	8	10	141.	0	2	3	4	9	10
142.	0	2	3	5	6	7	143.	0	2	3	5	6	8	144.	0	2	3	5	6	9
145.	0	2	3	5	6	10	146.	0	2	3	5	7	8	147.	0	2	3	5	7	9
148.	0	2	3	5	7	10	149.	0	2	3	5	8	9	150.	0	2	3	5	8	10
151.	0	2	3	5	9	10	152.	0	2	3	6	7	8	153.	0	2	3	6	7	9
154.	0	2	3	6	7	10	155.	0	2	3	6	8	9	156.	0	2	3	6	8	10
157.	0	2	3	6	9	10	158.	0	2	3	7	8	9	159.	0	2	3	7	8	10
160.	0	2	3	7	9	10	161.	0	2	3	8	9	10	162.	0	2	4	5	6	7
163.	0	2	4	5	6	8	164.	0	2	4	5	6	9	165.	0	2	4	5	6	10
166.	0	2	4	5	7	8	167.	0	2	4	5	7	9	168.	0	2	4	5	7	10
169.	0	2	4	5	8	9	170.	0	2	4	5	8	10	171.	0	2	4	5	9	10

172.	0	2	4	6	7	8	173.	0	2	4	6	7	9	174.	0	2	4	6	7	10
175.	0	2	4	6	8	9	176.	0	2	4	6	8	10	177.	0	2	4	6	9	10
178.	0	2	4	7	8	9	179.	0	2	4	7	8	10	180.	0	2	4	7	9	10
181.	0	2	4	8	9	10	182.	0	2	5	6	7	8	183.	0	2	5	6	7	9
184.	0	2	5	6	7	10	185.	0	2	5	6	8	9	186.	0	2	5	6	8	10
187.	0	2	5	6	9	10	188.	0	2	5	7	8	9	189.	0	2	5	7	8	10
190.	0	2	5	7	9	10	191.	0	2	5	8	9	10	192.	0	2	6	7	8	9
193.	0	2	6	7	8	10	194.	0	2	6	7	9	10	195.	0	2	6	8	9	10
196.	0	2	7	8	9	10	197.	0	3	4	5	6	7	198.	0	3	4	5	6	8
199.	0	3	4	5	6	9	200.	0	3	4	5	6	10	201.	0	3	4	5	7	8
202.	0	3	4	5	7	9	203.	0	3	4	5	7	10	204.	0	3	4	5	8	9
205.	0	3	4	5	8	10	206.	0	3	4	5	9	10	207.	0	3	4	6	7	8
208.	0	3	4	6	7	9	209.	0	3	4	6	7	10	210.	0	3	4	6	8	9
211.	0	3	4	6	8	10	212.	0	3	4	6	9	10	213.	0	3	4	7	8	9
214.	0	3	4	7	8	10	215.	0	3	4	7	9	10	216.	0	3	4	8	9	10
217.	0	3	5	6	7	8	218.	0	3	5	6	7	9	219.	0	3	5	6	7	10
220.	0	3	5	6	8	9	221.	0	3	5	6	8	10	222.	0	3	5	6	9	10
223.	0	3	5	7	8	9	224.	0	3	5	7	8	10	225.	0	3	5	7	9	10
226.	0	3	5	8	9	10	227.	0	3	6	7	8	9	228.	0	3	6	7	8	10
229.	0	3	6	7	9	10	230.	0	3	6	8	9	10	231.	0	3	7	8	9	10
232.	0	4	5	6	7	8	233.	0	4	5	6	7	9	234.	0	4	5	6	7	10
235.	0	4	5	6	8	9	236.	0	4	5	6	8	10	237.	0	4	5	6	9	10
238.	0	4	5	7	8	9	239.	0	4	5	7	8	10	240.	0	4	5	7	9	10
241.	0	4	5	8	9	10	242.	0	4	6	7	8	9	243.	0	4	6	7	8	10
244.	0	4	6	7	9	10	245.	0	4	6	8	9	10	246.	0	4	7	8	9	10
247.	0	5	6	7	8	9	248.	0	5	6	7	8	10	249.	0	5	6	7	9	10
250.	0	5	6	8	9	10	251.	0	5	7	8	9	10	252.	0	6	7	8	9	10

(6) NUMBER OF KINEMATIC CHAINS WITH 6 PRISM PAIRS = 174

# 1= 10:	41	42	47	48	49	57	58	59	82	83										
# 2= 8:	40	41	43	46	47	56	57	82												
# 3= 8:	37	38	41	72	73	76	128	129												
# 4= 18:	97	98	99	101	102	103	112	113	114	116	117	118	153	154	155	157	159			
158																				
# 5= 7:	16	76	77	78	79	82	135													
# 6= 6:	36	37	40	71	72	127														
# 7= 22:	37	38	40	41	46	47	72	73	75	76	81	82	97	101	128	129	131			
132	137	138	140	143																
# 8= 5:	82	83	85	93	94															
# 9= 11:	23	24	29	30	43	44	49	50	96	111	152									
# 10= 12:	37	40	47	49	53	57	59	61	65	69	72	75								
# 11= 7:	92	93	95	98	108	110	113													
# 12= 11:	40	47	49	52	57	59	62	75	82	84	94									
# 13= 28:	43	44	45	49	50	51	62	66	78	79	80	84	85	86	97	101	134			
135	136	140	141	142	153	154	155	157	158	159										
# 14= 6:	41	43	47	76	78	82														
# 15= 4:	37	40	46	75																
# 16= 11:	54	55	64	82	83	84	85	92	95	141	151									
1.	1	2	3	4	5	6	2.	1	2	3	4	5	7	3.	1	2	3	4	5	8
4.	1	2	3	4	5	9	5.	1	2	3	4	5	10	6.	1	2	3	4	6	7
7.	1	2	3	4	6	8	8.	1	2	3	4	6	9	9.	1	2	3	4	6	10
10.	1	2	3	4	7	8	11.	1	2	3	4	7	9	12.	1	2	3	4	7	10
13.	1	2	3	4	8	9	14.	1	2	3	4	8	10	15.	1	2	3	4	9	10
16.	1	2	3	5	6	7	17.	1	2	3	5	6	8	18.	1	2	3	5	6	9
19.	1	2	3	5	6	10	20.	1	2	3	5	7	8	21.	1	2	3	5	7	9
22.	1	2	3	5	7	10	23.	1	2	3	5	8	9	24.	1	2	3	5	8	10
25.	1	2	3	5	9	10	26.	1	2	3	6	7	8	27.	1	2	3	6	7	9
28.	1	2	3	6	7	10	29.	1	2	3	6	8	9	30.	1	2	3	6	8	10
31.	1	2	3	6	9	10	32.	1	2	3	7	8	9	33.	1	2	3	7	8	10



34.	1	2	3	7	9	10	35.	1	2	3	8	9	10	36.	1	2	4	5	6	7
37.	1	2	4	5	6	8	38.	1	2	4	5	6	9	39.	1	2	4	5	6	10
40.	1	2	4	5	7	8	41.	1	2	4	5	7	9	42.	1	2	4	5	7	10
43.	1	2	4	5	8	9	44.	1	2	4	5	8	10	45.	1	2	4	5	9	10
46.	1	2	4	6	7	8	47.	1	2	4	6	7	9	48.	1	2	4	6	7	10
49.	1	2	4	6	8	9	50.	1	2	4	6	8	10	51.	1	2	4	6	9	10
52.	1	2	4	7	8	9	53.	1	2	4	7	8	10	54.	1	2	4	7	9	10
55.	1	2	4	8	9	10	56.	1	2	5	6	7	8	57.	1	2	5	6	7	9
58.	1	2	5	6	7	10	59.	1	2	5	6	8	9	60.	1	2	5	6	8	10
61.	1	2	5	6	9	10	62.	1	2	5	7	8	9	63.	1	2	5	7	8	10
64.	1	2	5	7	9	10	65.	1	2	5	8	9	10	66.	1	2	6	7	8	9
67.	1	2	6	7	8	10	68.	1	2	6	7	9	10	69.	1	2	6	8	9	10
70.	1	2	7	8	9	10	71.	1	3	4	5	6	7	72.	1	3	4	5	6	8
73.	1	3	4	5	6	9	74.	1	3	4	5	6	10	75.	1	3	4	5	7	8
76.	1	3	4	5	7	9	77.	1	3	4	5	7	10	78.	1	3	4	5	8	9
79.	1	3	4	5	8	10	80.	1	3	4	5	9	10	81.	1	3	4	6	7	8
82.	1	3	4	6	7	9	83.	1	3	4	6	7	10	84.	1	3	4	6	8	9
85.	1	3	4	6	8	10	86.	1	3	4	6	9	10	87.	1	3	4	7	8	9
88.	1	3	4	7	8	10	89.	1	3	4	7	9	10	90.	1	3	4	8	9	10
91.	1	3	5	6	7	8	92.	1	3	5	6	7	9	93.	1	3	5	6	7	10
94.	1	3	5	6	8	9	95.	1	3	5	6	8	10	96.	1	3	5	6	9	10
97.	1	3	5	7	8	9	98.	1	3	5	7	8	10	99.	1	3	5	7	9	10
100.	1	3	5	8	9	10	101.	1	3	6	7	8	9	102.	1	3	6	7	8	10
103.	1	3	6	7	9	10	104.	1	3	6	8	9	10	105.	1	3	7	8	9	10
106.	1	4	5	6	7	8	107.	1	4	5	6	7	9	108.	1	4	5	6	7	10
109.	1	4	5	6	8	9	110.	1	4	5	6	8	10	111.	1	4	5	6	9	10
112.	1	4	5	7	8	9	113.	1	4	5	7	8	10	114.	1	4	5	7	9	10
115.	1	4	5	8	9	10	116.	1	4	6	7	8	9	117.	1	4	6	7	8	10
118.	1	4	6	7	9	10	119.	1	4	6	8	9	10	120.	1	4	7	8	9	10
121.	1	5	6	7	8	9	122.	1	5	6	7	8	10	123.	1	5	6	7	9	10
124.	1	5	6	8	9	10	125.	1	5	7	8	9	10	126.	1	6	7	8	9	10
127.	2	3	4	5	6	7	128.	2	3	4	5	6	8	129.	2	3	4	5	6	9
130.	2	3	4	5	6	10	131.	2	3	4	5	7	8	132.	2	3	4	5	7	9
133.	2	3	4	5	7	10	134.	2	3	4	5	8	9	135.	2	3	4	5	8	10
136.	2	3	4	5	9	10	137.	2	3	4	6	7	8	138.	2	3	4	6	7	9
139.	2	3	4	6	7	10	140.	2	3	4	6	8	9	141.	2	3	4	6	8	10
142.	2	3	4	6	9	10	143.	2	3	4	7	8	9	144.	2	3	4	7	8	10
145.	2	3	4	7	9	10	146.	2	3	4	8	9	10	147.	2	3	5	6	7	8
148.	2	3	5	6	7	9	149.	2	3	5	6	7	10	150.	2	3	5	6	8	9
151.	2	3	5	6	8	10	152.	2	3	5	6	9	10	153.	2	3	5	7	8	9
154.	2	3	5	7	8	10	155.	2	3	5	7	9	10	156.	2	3	5	8	9	10
157.	2	3	6	7	8	9	158.	2	3	6	7	8	10	159.	2	3	6	7	9	10
160.	2	3	6	8	9	10	161.	2	3	7	8	9	10	162.	2	4	5	6	7	8
163.	2	4	5	6	7	9	164.	2	4	5	6	7	10	165.	2	4	5	6	8	9
166.	2	4	5	6	8	10	167.	2	4	5	6	9	10	168.	2	4	5	7	8	9
169.	2	4	5	7	8	10	170.	2	4	5	7	9	10	171.	2	4	5	8	9	10
172.	2	4	6	7	8	9	173.	2	4	6	7	8	10	174.	2	4	6	7	9	10
175.	2	4	6	8	9	10	176.	2	4	7	8	9	10	177.	2	5	6	7	8	9
178.	2	5	6	7	8	10	179.	2	5	6	7	9	10	180.	2	5	6	8	9	10
181.	2	5	7	8	9	10	182.	2	6	7	8	9	10	183.	3	4	5	6	7	8
184.	3	4	5	6	7	9	185.	3	4	5	6	7	10	186.	3	4	5	6	8	9
187.	3	4	5	6	8	10	188.	3	4	5	6	9	10	189.	3	4	5	7	8	9
190.	3	4	5	7	8	10	191.	3	4	5	7	9	10	192.	3	4	5	8	9	10
193.	3	4	6	7	8	9	194.	3	4	6	7	8	10	195.	3	4	6	7	9	10
196.	3	4	6	8	9	10	197.	3	4	7	8	9	10	198.	3	5	6	7	8	9
199.	3	5	6	7	8	10	200.	3	5	6	7	9	10	201.	3	5	6	8	9	10
202.	3	5	7	8	9	10	203.	3	6	7	8	9	10	204.	4	5	6	7	8	9
205.	4	5	6	7	8	10	206.	4	5	6	7	9	10	207.	4	5	6	8	9	10
208.	4	5	7	8	9	10	209.	4	6	7	8	9	10	210.	5	6	7	8	9	10

2

VITA

Matthew Huang

Candidate for the Degree of

Doctor of Philosophy

Thesis: APPLICATION OF LINEAR AND NON-LINEAR GRAPHS IN STRUCTURAL  
SYNTHESIS OF KINEMATIC CHAINS

Major Field: Mechanical Engineering

Biographical:

Personal Data: Born in Tacichung, Taiwan, October 13, 1941, the son of I-Mei and Chin-Su Huang. On March 21, 1970, married Becky Tung.

Education: Graduated from the Taichung First Middle School in 1960; received the Bachelor of Science degree in Mechanical Engineering from Cheng-Kung University, Taiwan, in 1964. Completed Electronic Computer Training course at the Research and Training Center for Electronics and Telecommunication under the United Nations Special Fund in Taiwan, 1967; received the Master of Science degree in Mechanical Engineering from Oklahoma State University, in 1968; completed the requirements for the degree of Doctor of Philosophy at Oklahoma State University in May, 1972.

Professional Experience: Teaching at Taiwan Kwan-Hwa Institute of Technology, from July, 1965 to July, 1966; working on Motion and Time Study and Machine Design at Taiwan Da-Hsin Plastics Processing Company, from Aug. 1966 to July, 1967; working part time as Graduate Research and Teaching assistant at Department of Mechanical Engineering, Oklahoma State University, supported by National Science Foundation, from Sept., 1968 to July, 1971.

Professional Organization: Associate Member of American Society of Mechanical Engineering.