

March 2015

Architecting NP-Dynamic Skybridge

Jiajun Shi
University of Massachusetts Amherst

Follow this and additional works at: https://scholarworks.umass.edu/masters_theses_2



Part of the [Electronic Devices and Semiconductor Manufacturing Commons](#), [Nanotechnology Fabrication Commons](#), and the [VLSI and Circuits, Embedded and Hardware Systems Commons](#)

Recommended Citation

Shi, Jiajun, "Architecting NP-Dynamic Skybridge" (2015). *Masters Theses*. 171.
<https://doi.org/10.7275/6453453> https://scholarworks.umass.edu/masters_theses_2/171

This Open Access Thesis is brought to you for free and open access by the Dissertations and Theses at ScholarWorks@UMass Amherst. It has been accepted for inclusion in Masters Theses by an authorized administrator of ScholarWorks@UMass Amherst. For more information, please contact scholarworks@library.umass.edu.

ARCHITECTING NP-DYNAMIC SKYBRIDGE

A Thesis Presented

by

JIAJUN SHI

Submitted to the Graduate School of the
University of Massachusetts Amherst in partial fulfillment
of the requirements for the degree of

MASTER OF SCIENCE IN ELECTRICAL AND COMPUTER ENGINEERING

February 2015

Department of Electrical and Computer Engineering

© Copyright by Jiajun Shi 2015
All Rights Reserved

ARCHITECTING NP-DYNAMIC SKYBRIDGE

A Thesis Presented

by

JIAJUN SHI

Approved as to style and content by:

Csaba Andras Moritz, Chair

Israel Koren, Member

C. Mani Krishna, Member

Christopher V. Hollot, Department Head
Electrical and Computer Engineering

ACKNOWLEDGEMENTS

I would like to gratefully and sincerely thank Dr. Csaba Andras Moritz for his guidance, understanding and patience throughout my graduate study at Umass Amherst. His mentorship was paramount in providing me correct attitude of doing research and proper method to present ideas. He encouraged me to not only grow as a programmer but also as an independent thinker. For everything you've done for me, Dr. Moritz, I thank you. I would also like to thank the members of the Skybridge research group, especially Mostafizur Rahman, Santosh Khasanvis and my good partner Mingyu Li for their consistent help during my Master study. I would like to thank the Electrical and Computer Engineering Department of Umass Amherst for the support, which turns my dream into reality. In addition, I would also thank all members in my Master Thesis committee, Drs. Csaba Andras Moritz, Israel Koren, and C. Mani Krishna, for their significant help from proposal to the final defense.

I want to thank my parents, Jidong Shi and Aisu Xu, for their selfless and endless love to me. Also for my uncle Jiqiang Shi, thanks for his selfless support for my study in America.

Thank you, to all of you!

ABSTRACT

ARCHITECTING NP-DYNAMIC SKYBRIDGE

FEBRUARY 2015

B.Eng., UNIVERSITY OF ELECTRONIC SCIENCE AND TECHNOLOGY OF
CHINA, CHENG DU, CHINA

M.S.E.C.E., UNIVERSITY OF MASSACHUSETTS, AMHERST

Directed by: Professor Csaba Andras Moritz

With the scaling of technology nodes, modern CMOS integrated circuits face severe fundamental challenges that stem from device scaling limitations, interconnection bottlenecks and increasing manufacturing complexities. These challenges drive researchers to look for revolutionary technologies beyond the end of CMOS roadmap. Towards this end, a new nanoscale 3-D computing fabric for future integrated circuits, Skybridge, has been proposed [1]. In this new fabric, core aspects from device to circuit style, connectivity, thermal management and manufacturing pathway are co-architected in a 3-D fabric-centric manner.

However, the Skybridge fabric uses only n-type transistors in a dynamic circuit style for logic and memory implementations. Therefore, it requires complicated clocking schemes to overcome signal monotonicity associated with cascading dynamic logic gates. For Skybridge's large-scale circuits, the dynamic circuit style requires cascaded stages to be micro-pipelined, which results in large number of buffers used for storing minterms causing significant overhead in terms of area and power. Moreover, implementation of logic is limited to NAND or AND-of-NAND

based logic expressions, which does not always result in compact circuits. In this work, we propose an extension of original Skybridge fabric, called NP-Dynamic-Skybridge, to solve these challenges by using both n-and p-type transistors in an innovative circuit style. Here, every stage in a given circuit is implemented by either n-type or p-type dynamic logic.

Cascading n- and p-type dynamic logic effectively avoids signal monotonicity problem, and allows combinational-like circuit implementation. This helps to simplify the clocking scheme for cascaded logics requiring only one set of global precharge and evaluate clock signals. And also it expands the degree of expressing logic enabling expressions such as NOR, OR-of-NORs, in addition to those previously mentioned. Furthermore, the number of pipeline stages is significantly reduced for a given logic function, and buffer requirements are less compared with Skybridge 3D fabric thus improving on area and power metrics.

TABLE OF CONTENTS

	Page
ACKNOWLEDGEMENTS	iv
ABSTRACT.....	v
LIST OF TABLES.....	ix
LIST OF FIGURES.....	x
CHAPTER.....	1
1. INTRODUCTION AND MOTIVATION.....	1
2. OVERVIEW OF SKYBRIDGE FABRIC	5
2.1 Core Fabric Components and Elementary Circuits	6
2.1.1 Vertical Silicon Nanowires	6
2.1.2 Vertical Gate-All-Around Transistor and NAND gate	7
2.1.3 Elementary circuits built on vertical nanowires	7
2.2 Challenges of Skybridge Fabric	9
2.2.1 Limited Type of Gate Logic	9
2.2.2 Complicated Control Clock.....	10
2.2.3 Large Overhead Due To Buffers.....	10
2.3 Chapter Summary	11
3. NP-DYNAMIC-SKYBRIDGE FABRIC OVERVIEW AND CORE	
COMPONENTS.....	12
3.1 NP-Dynamic-Skybridge Fabric Overview.....	12
3.2 Core Components of NP-Dynamic-Skybridge Fabric	12
3.2.1 Vertical Nanowires	12
3.2.2 Vertical Gate-All-Around Transistor	14
3.2.3 Coaxial Routing Structure	16
3.2.4 Ohmic contact and bridge.....	17
3.3 Chapter Summary	18
4. ELEMENTARY CIRCUITS	19

4.1 Logic Nanowire	19
4.2 Compound Gate	20
4.3 Cascaded Gates	21
4.3 Chapter Summary	23
5. BENCHMARKING AND RESULTS	24
5.1 Benchmarking Methodology	24
5.2 Benchmarking Results and Scalability	25
5.2.1 Benchmarking of 4-bit Carry Look-Ahead Adder	25
5.2.2 Results of Benchmarking	26
5.3 Chapter Summary	27
6. FAN-IN ANALYSIS AND SCALABILITY	28
6.1 Fan-in Analysis	28
6.1.1 Evaluation Methodology	28
6.1.2 Fan-in Sensitivity Analysis.....	29
6.2 Scalability and Larger Scale Benchmarking.....	31
6.2.1 Scalability Study.....	31
6.2.2 Benchmarking for Larger Scale Design	31
6.3 Chapter Summary	32
7. WIRE STREAM PROCESSOR BENCHMARKING	33
7.1 Optimized Pipelining scheme	33
7.1.1 Pipelining Scheme in Skybridge Fabric	33
7.1.2 Proposed Pipelining Scheme of NP-Dynamic Skybridge	35
7.1.3 Timing and Clock Optimization	35
7.2 WISP-4 Benchmarking	38
7.2.1 WISP-4 Circuit and Architecture.....	38
7.2.2 Benchmarking Results.....	40
7.3 Chapter Summary	41
BIBLIOGRAPHY	42

LIST OF TABLES

Table	Page
3.1 On/Off current of 16nm 3-D GAA junctionless device	15
3.2 On/Off current of 16nm Fin-Fet device	16
5.1 Evaluation results of 4-bit CLA	27

LIST OF FIGURES

Figure	Pages
1.1 I_{off} versus L_{eff} at $V_{\text{DD}}=1$ V for bulk-Si and Double-Gate devicesimplemented inverters	1
1.2 Trend of: A) supply voltage and B) threshold voltage for various versions of ITRS	2
1.3 Relative performance at constant power density	2
1.4 Lithographic challenges with scaling	3
2.1 Abstract view of envisioned skybridge fabric.....	5
2.2 Silicon nanowires on bulk substrate	6
2.3 GAA transistor and I-V characteristic	7
2.4 Schematic and layout of 3-input NAND gate.....	8
2.5 Skybridge 1-bit Full Adder	8
2.6 Logic implementation comparison	9
2.7 Separate stages design of carry look-ahead adder	11
3.1 Vertically stacked dual-doped Substrate	13
3.2 Dual-doped nanowire array.....	13
3.3 Vertical GAA junctionless transistors	14
3.4 Transistors IV Characteristics	15
3.5 Coaxial routing structure and bypass routing layer	16
3.6 Ohmic contact for n-type silicon.....	18
4.1 NAND gate and NOR gate in NP-Dynamic-Skybridge fabric	20
4.2 XOR gate layout	21
4.3 Cascaded gates and waveform validation	22
5.1 Block diagram of 4-bit CLA	26
6.1 Example gate for fan-in sensitivity analysis	29

6.2 Fan-in sensitivity curves	30
6.3 Determination for maximum fan-in for NP-Dynamic	31
6.4 Evaluation results of 4-bit and 8-bit CLAs	32
7.1 Pipelining Scheme of Skybridge.....	34
7.2 Pipelining Scheme of NP-Dynamic Skybridge.....	35
7.3 Timing of NP-Dynamic Skybridge	37
7.4 Timing of NP-Dynamic Skybridge	37
7.5 Clock Optimization.....	38
7.6 Architecture Block Diagram	40
7.7 WISP-4 Benchmarking Results	41

CHAPTER 1

INTRODUCTION AND MOTIVATION

Tremendous progress in miniaturization of integrated circuits (ICs) has been crucial for the socio-economic developments in the last century. So far, this miniaturization was mainly enabled by the ability to continuously scale the CMOS technology. As the scale of CMOS technology nodes goes down, it is faced with several challenges and special difficulty to maintain the traditional way of scaling. Firstly, in terms of the devices, technology scaling enhances short channel effects, resulting in the larger off-leakage current [2]. What's more, as the device scales down, the threshold voltage and V_{DD} value do not go down linearly [2], which results in degradations of performance and power in building circuits with high density.

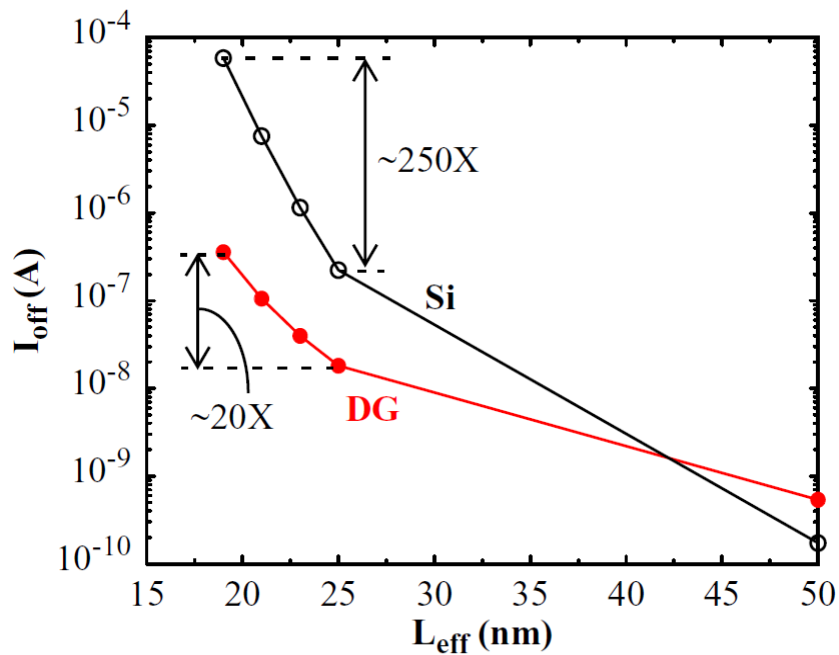

Figure. 1.1 I_{off} versus L_{eff} at $V_{DD}=1$ V for bulk-Si and Double-Gate devices implemented inverters [3]

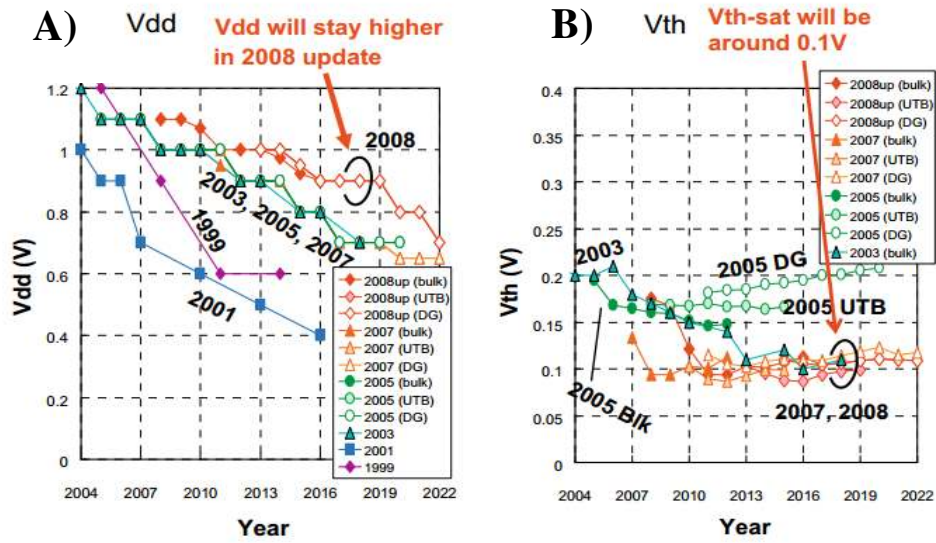

Figure. 1.2 Trend of: A) supply voltage and B) threshold voltage for various versions of ITRS [2]

As more transistors integrated into the same die area, it becomes difficult to design compact circuits and routings. Large resistance and capacitance from interconnections cause significant degradation in circuit's performance and power. Microprocessor's performance is faced with a corner and taken into a bottleneck [4]. And the power density of a microprocessor will soon climb beyond the capabilities of any possible cooling techniques in the future.

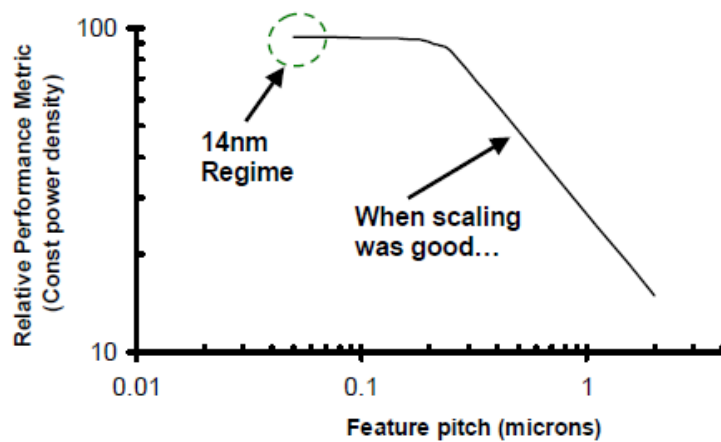

Figure. 1.3 Relative performance at constant power density [4]

The increased defects and parameter variations during manufacturing also challenge current CMOS technology. The lithography technology can't cope with the shrinking feature size of CMOS layout because it is limited by difficulties in controlling mask-wafer gap and uniform exposure of photoresists on wafer respectively. And large mismatch of manufactured CMOS layout has big impact on the microprocessor's reliability.

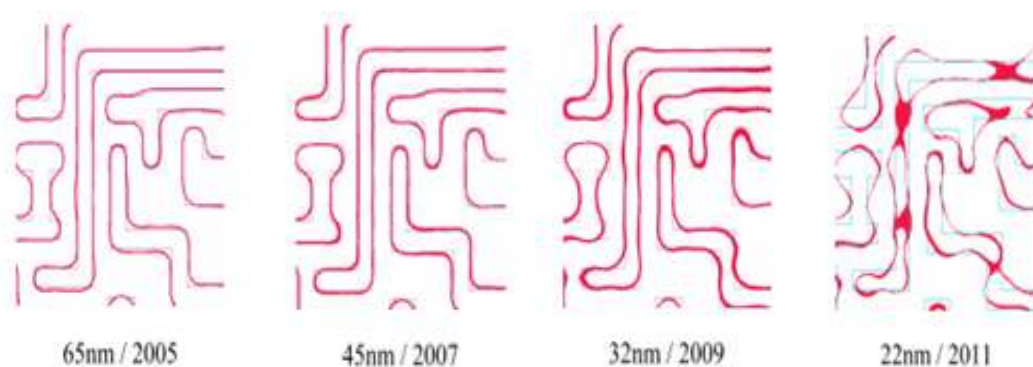

Figure. 1.4 **Lithographic challenges with scaling [4]**

Being faced with the challenges mentioned above, an emerging concept of integrated circuits, Skybridge, has been proposed with 3-D integrated circuits based on vertical silicon nanowires [1]. Compared with conventional 2-D CMOS technology, it has compact circuits and connectivity through building 3-D routing wires and transistors. And the junctionless Gate-All-Around transistors built on vertical nanowire can effectively suppress leakage. In addition, the fabrication of interconnections and transistors are dependent on material deposition and not on optical lithography precision. However, the Skybridge fabric uses only n-type transistors in a dynamic circuit style to implement arbitrary logics. This leads to complex control clock system, limitation of logic expression's implementation and

large overhead due to buffers in large-scale synchronous micro pipeline. We will detail these challenges in chapter 2.

In this thesis, we propose a new approach which makes optimization over the Skybridge fabric by incorporating n- and p-type transistors. This new approach tries to avoid typical monotonicity problem by cascading n- and p-type dynamic logics. It uses the dynamic logic style with precharge and evaluate clocks. And it implements the logics following a combinational-like logic style which enables all stages of a given to be evaluated together in one clock period. This approach not only reduces the requirement of complex control clock system and also provides various choices for logic implementation. Additionally, the static-like implementation of circuit helps to reduce buffers in large-scale synchronous pipeline design and build up compact single-rail logic circuits with optimum performance and low power.

The rest of the thesis is organized as follows: Chapter 2 presents the overview of Skybridge fabric and what are the challenges in this fabric. The chapter 3 discusses the proposed new fabric and its core components. Based on the basic fabric presented in Chapter 3, Chapter 4 provides the elementary circuits and how the new fabric can achieve diverse logics. The Chapter 5 mainly focuses on the initial evaluation of the proposed fabric by benchmarking 4-bit carry look-ahead adder (CLA). Chapter 6 presents how to gain high fan-in gate in the proposed fabric and the scalability for large-scale benchmark. Finally, in chapter 7, we will show the large scale benchmark of 4-bit microprocessor with an optimized pipelining scheme.

CHAPTER 2

OVERVIEW OF SKYBRIDGE FABRIC

In order to make revolution and search for a new roadmap of integrated circuits, researchers come up with the 3-D integrated circuits concepts based on vertical nanowires, shown in the previously proposed Skybridge fabric [1]. It tries to eliminate the challenges of current CMOS integration and explores a world of 3-D integrated circuits which is built from bottom-up includes the manufacturability, fabrication, device physics, circuits style and microprocessor design. Based on its fundamental building block, nanowires array, gate-all-around transistors are stacked vertically on the nanowires to build elementary NAND gates. Large-scale integrated circuits can be built by cascading these NAND gates with compact 3-D interconnections and routings.

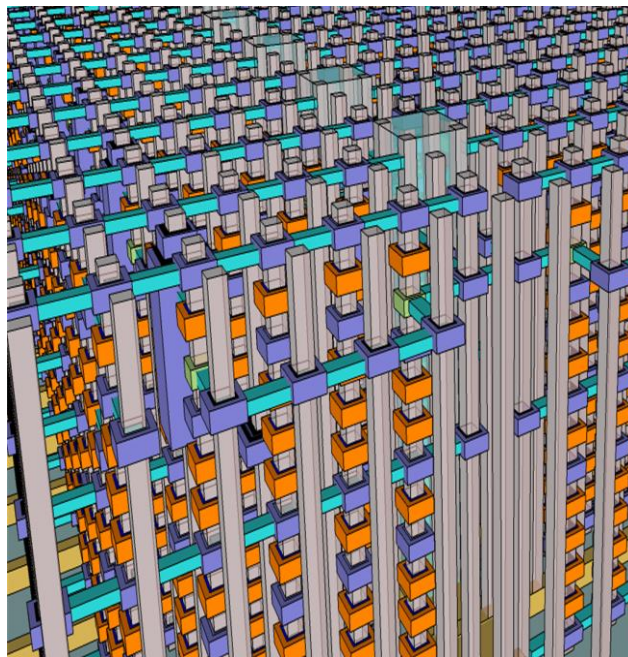

Figure.2.1 Abstract view of envisioned skybridge fabric [1]

2.1 Core Fabric Components and Elementary Circuits

2.1.1 Vertical Silicon Nanowires

In Skybridge fabric, the 3-D integrated circuits are built following bottom-up architecture style with compact routing structure to deal with key requirements of current integrated circuits design. Regular Arrays of single crystal vertical silicon nanowires are fundamental building blocks of Skybridge fabric. These nanowires are classified such that some of them are used as (i) *logic nanowires* to implement basic NAND gate logic consisting of a stack of vertical transistors, and (ii) *signal nanowires* as conducting wires to carry Input/Output/Global signals between cascaded gates. Heavily doping is a key requirement for these nanowires, because it is necessary for building low-resistance vertical Gate-All-Around (GAA) transistors. Another secondary characteristic of these nanowires is that the signal nanowires should be silicided to reduce electrical resistance as they are used as conducting wires for carrying signals between cascaded gates. Figure. 2.2 shows arrays of regular vertical silicon nanowires that are patterned on highly doped silicon substrate.

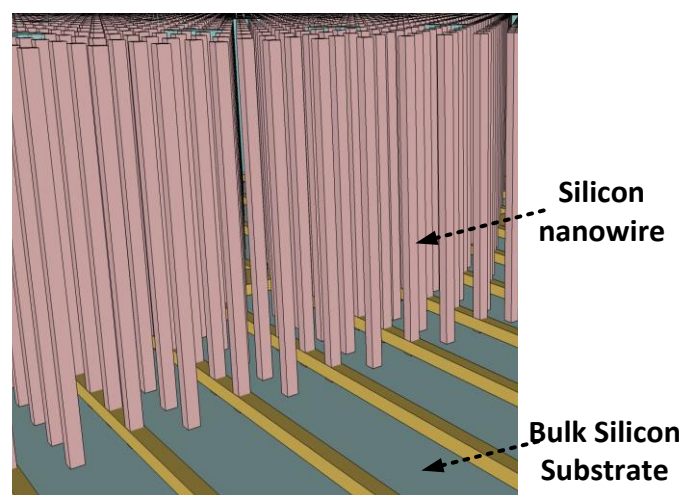

Figure.2.2 Silicon nanowires on bulk substrate [1]

2.1.2 Vertical Gate-All-Around Transistor and NAND gate

As mentioned in Chapter 1, as the feature size of current CMOS devices shrinks, the short channel effects has significant negative impact on device's leakage. Based on the crystal nanowires, the Skybridge fabric builds stacked 16nm gate-all-around (GAA) vertical transistors [5]. This device is well-suited in Skybridge fabric because it effectively suppresses the short channel effects to reduce leakage for below-20nm transistor. What's more, they eliminate the requirement of precise doping of devices' manufacturing and are entirely dependent on deposition technology but not optical lithography precision. The structure of the GAA vertical transistor with 16nm feature size and its I-V characteristic are shown in the Figure. 2.2.

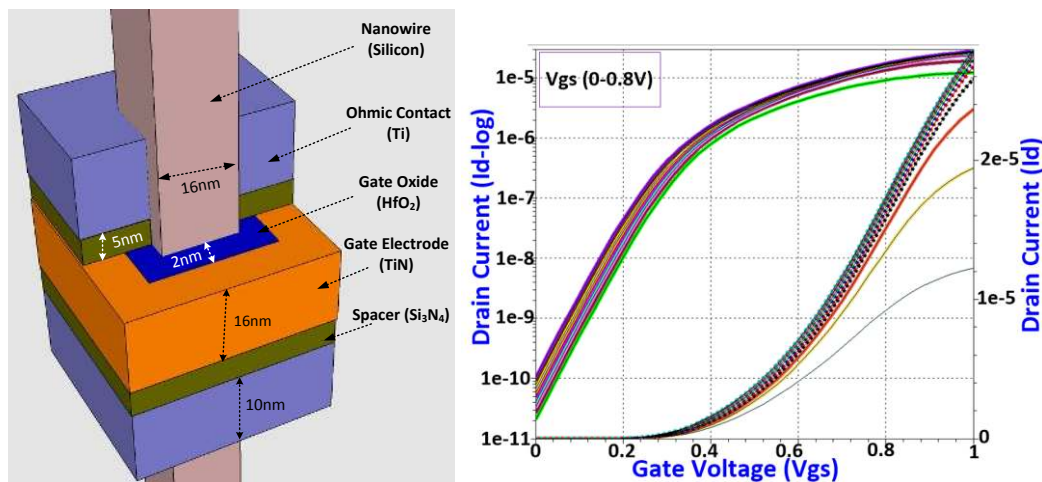

Figure.2.3 GAA transistor and I-V characteristic [1]

2.1.3 Elementary circuits built on vertical nanowires

Based on the crystal vertical nanowires array, Skybridge fabric builds stacked GAA transistors vertically on every nanowire to implement NAND gates. The implementation of single NAND gate is shown in the Figure. 2.3. All the nanowires are uniform with VDD terminal on the top and GND terminal on the bottom.

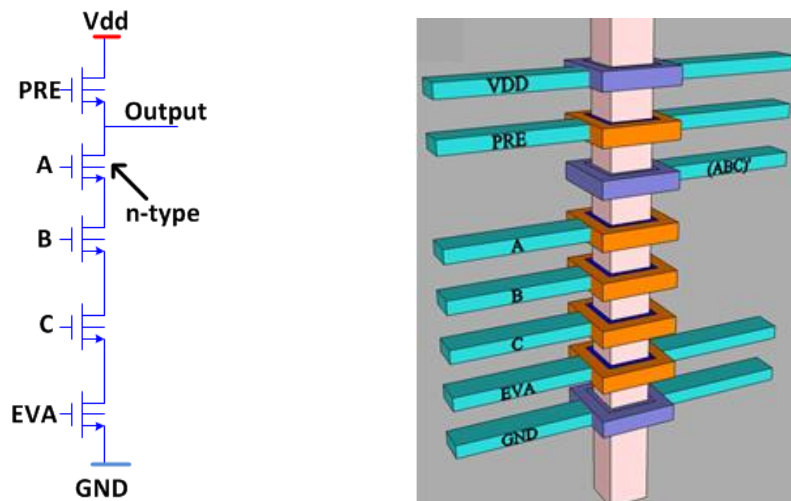

Figure.2.4 Schematic and layout of 3-input NAND gate

By using signal nanowires to connect and conducting Input/Output signals between cascaded NAND gates, Skybridge can build NAND-NAND cascaded logic [1]. And if we connect the output nodes of NAND gates together, compound gate [6] can be built with AND-of-NANDs logic. Figure. 2.3 shows the logic implementation for 1-bit full adder with compound

gates in AND-of-NANDs logic. Uniform n-type transistors are used to construct the circuits and one set of precharge/evaluate clock signal is used to control the execution of logic.

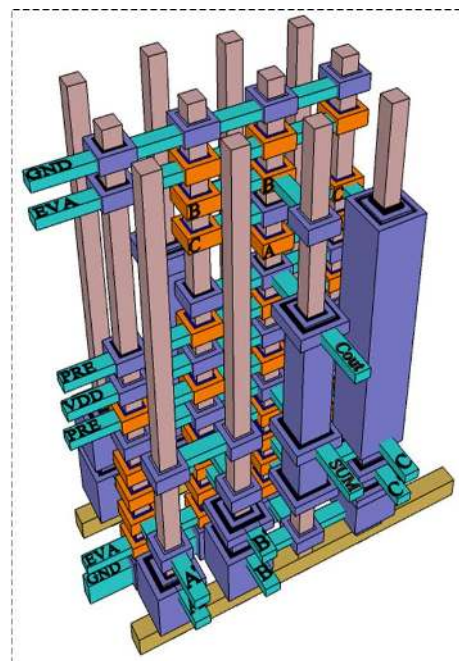

Figure.2.5 Skybridge 1-bit Full Adder

2.2 Challenges of Skybridge Fabric

The Skybridge fabric uses only n-type transistors to implement arbitrary logic with dynamic circuit style. This leads to complex control clocking scheme, limitation of logic expression's implementation and large overhead due to buffers in large-scale synchronous micro-pipeline design.

2.2.1 Limited Type of Gate Logic

NAND logic is built by stacking n-type transistors vertically on logic nanowire. And a compound gate with AND of NANDs logic can be implemented by connecting the output nodes of logic nanowires together. However, these logics are not enough to provide compact circuits design. In Figure. 2.6, we show the true logic expression 'ABC+EF' is simply implemented with OR-of-NORs logic while it uses much more transistors when implemented with AND of NANDs logic. On the other hand, when implementing its complementary logic expression, $\overline{ABC + EF}$, AND of NANDs logic provides a more compact implementation.

$$\begin{array}{l}
 ABC + EF \\
 = \overline{\overline{A}\overline{E}} \cdot \overline{\overline{A}\overline{F}} \cdot \overline{\overline{B}\overline{E}} \cdot \overline{\overline{B}\overline{F}} \cdot \overline{\overline{C}\overline{E}} \cdot \overline{\overline{A}\overline{F}} \\
 = \overline{\overline{A} + \overline{B} + \overline{C} + \overline{E} + \overline{F}} \quad \text{AND of NANDs logic} \\
 \quad \quad \quad \swarrow \text{OR of NORs logic}
 \end{array}
 \qquad
 \begin{array}{l}
 \overline{ABC + EF} \\
 = \overline{ABC} \cdot \overline{EF} \quad \swarrow \text{AND of NANDs logic} \\
 = \overline{(A + E) + (A + F) + (B + E)} \\
 \quad + \overline{(B + F) + (C + E) + (C + F)} \\
 \quad \quad \quad \swarrow \text{OR of NORs logic}
 \end{array}$$

Figure.2.6 Logic implementation comparison

In the proposed NP-Dynamic-Skybridge, we can have both AND-of-NANDs logic and OR-of-NORs logic. This results in more flexibility in circuits' design and helps us

to gain the most compact design for a given logic.

2.2.2 Complicated Control Clock

Since the cascaded gates are all implemented with n-type logic, there will be typical monotonicity problem [6] between cascaded n-type dynamic logic gates which results in functional errors, if all the cascaded gates' evaluation periods are set to be finished in the same clock period. In order to avoid this problem, the stages of a given circuit are evaluated separately which requires several sets of precharge and evaluate clocks to be set up to control and synchronize the pipeline. Therefore, it complicates the clock system's design. Additionally, if take the clock skew and jet into account, it hurts the circuits' function and reliability.

2.2.3 Large Overhead Due To Buffers

In the last section, we explained why the circuit has to be partitioned into several stages and all stages are evaluated in separated clock periods. In addition, because of using dynamic logic style, each stage's output signals should be restored for synchronous micro pipelining. As we show in Figure.2.7, the Propagation signals, which are generated in the first stage, are stored in the buffers during the second stage and carried to the third stage for the evaluation of final results. Therefore, for any given circuit with separated stages, buffers are used for storing and carrying the output signals between different stages. It causes large overhead of area and even hurts the power and performance of large-scale pipeline design.

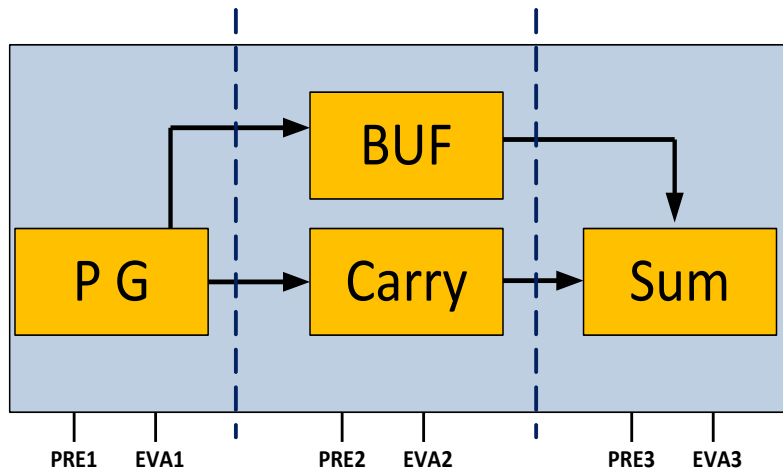

Figure.2.7 Separate stages design of carry look-ahead adder

2.3 Chapter Summary

In this chapter, the overview of the Skybridge integration fabric was presented. We illustrated its core components and how people came up with basic concepts to eliminate current challenges in conventional 2-D CMOS design. In addition, we discussed the challenges of Skybridge fabric including logic implementations, complexity of clock system and large overhead from buffers.

We will introduce the NP-Dynamic-Skybridge fabric in the next chapter and explain how it can eliminate these challenges and make optimization over Skybridge fabric.

CHAPTER 3

NP-DYNAMIC-SKYBRIDGE FABRIC OVERVIEW AND CORE COMPONENTS

3.1 NP-Dynamic-Skybridge Fabric Overview

Skybridge fabric follows a fabric-centric mindset, assembling structure on a 3-D uniform template of single crystal vertical nanowires, keeping 3-D requirements, compatibility, and overall efficiency as its central goals. And the proposed NP-Dynamic-Skybridge traces on similar roadmap of Skybridge fabric and makes extension to achieve more benefits.

Following the idea of Skybridge, we try to extend its basic concepts by incorporating both n-type and p-type transistors in the new approach. It is built from bottom-up by stacking n- and -p type devices on dual-doped nanowire through material deposition. Proper materials are chosen to construct low-resistance contacts for n-type and p-type doped regions of each nanowire. New coaxial routing structures which are connected with bridges are proposed to primarily satisfy connectivity. In this chapter, we detail the core components of this new fabric and how it is used in unison to achieve desired functionality.

3.2 Core Components of NP-Dynamic-Skybridge Fabric

3.2.1 Vertical Nanowires

In the proposed fabric, the 3-D circuits are built by incorporating both n- and p-types devices on each vertical dual-doped nanowire. Vertical nanowires are core building blocks patterned from heavily doped silicon substrate. Therefore, it requires

the preparation of the substrate which has both n- and p-type doped regions. However, the scheme of doping the substrate surface separately region by region through ion implantation technology is not feasible because this technology is bad at doping region's lateral control. Instead, we come up with a stacked doped layers' structure for the preparation of vertically dual-doped substrate. It is shown in the Figure. 3.1.

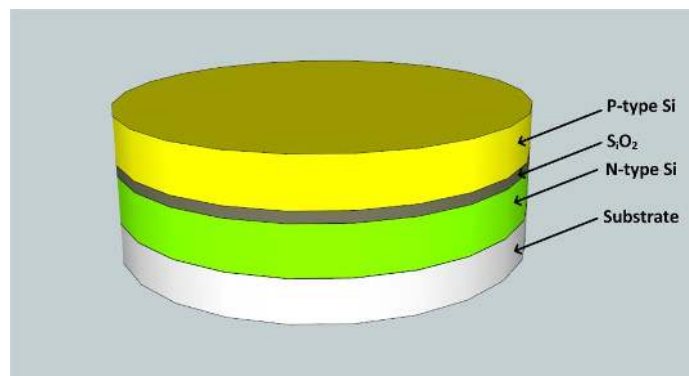

Figure.3.1 **Vertically stacked dual-doped Substrate**

Such a dual-doped substrate with vertically stacked silicon layers is formed by bonding two heavily n-type and p-type doped substrates through molecular bonding technology [7][8]. Between the n-type and p-type doped silicon layers, there is a silicon dioxide layer for isolation. After preparation of such substrate, we pattern out the dual-doped nanowires array, as shown in Figure. 3.2.

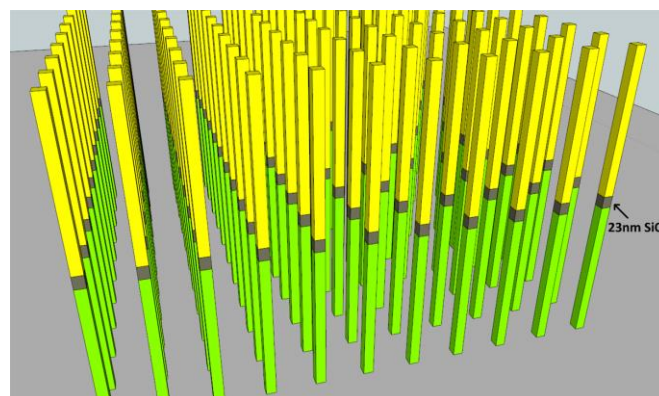

Figure.3.2 **Dual-doped nanowire array**

3.2.2 Vertical Gate-All-Around Transistor

In Skybridge fabric, people choose n-type Gate-All-Around junctionless transistor with uniform doping in Drain/Source/Channel eliminating the requirement of abrupt doping variations within the devices. Similarly, Gate-All-Around (GAA) transistors are chosen as active device for NP-Dynamic Skybridge fabric. We build both n-type and p-type GAA transistors vertically on every nanowire and each type of transistor is built on its respectively doped region. Both of them are junctionless transistors whose channel conduction is modulated by the workfunction difference between the heavily doped channel and the gate [9]. Titanium nitride and tungsten nitride are chosen as gate materials for n-type and p-type transistors to provide proper workfunction for gate control [10][11]. Figure. 3.3 shows the structures of both devices. Based on the device process emulation of Synopsys Sentaurus tool, IV characteristics of both devices are carried out and shown in Figure. 3.4.

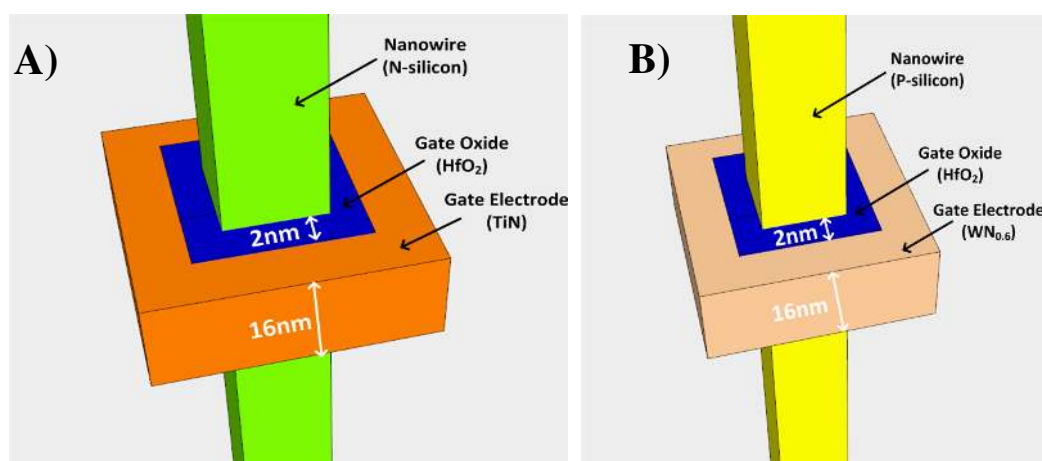

Figure.3.3 Vertical GAA junctionless transistors: A) n-type transistor with gate material TiN and B) p-type transistor with gate material WN_{0.6}

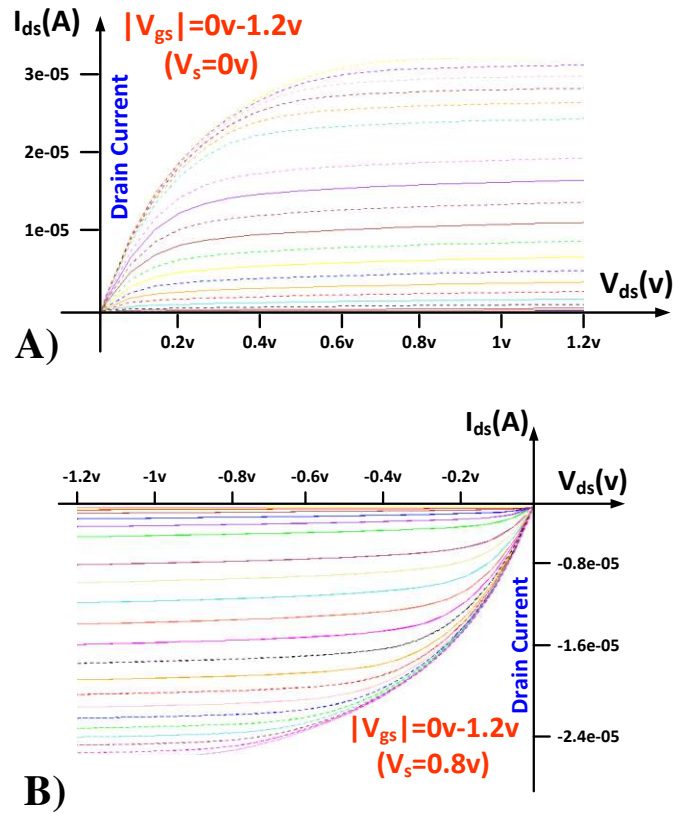

Figure.3.4 **Transistors IV Characteristics:** A) n-type transistor IV curve and B) p-type transistor IV curve

However, junctionless transistor has its intrinsic weakness. When it is on, it works on accumulation model [18]. Therefore, the junctionless transistor's on current is much less than the on current of junction transistor [19], which works on inversion model. Table II and Table III show the comparison of on current, off current and their ratio of 3-D junctionless GAA device and conventional CMOS Fin-Fet device with AUS PTM Model [20].

Table.3.1 **On/Off current of 16nm 3-D GAA junctionless device**

Device	I_{on}	I_{off}	I_{on}/I_{off}
VNJT-n-type	16.3uA	0.095nA	1.72E05
VNJT-p-type	16uA	0.76nA	2.11E04

Table.3.2 On/Off current of 16nm Fin-Fet device

Device	I_{on}	I_{off}	I_{on}/I_{off}
Fin-Fet n-type	103.75uA	6.02nA	1.72E04
Fin-Fet p-type	74.7uA	5.23nA	1.4E04

3.2.3 Coaxial Routing Structure

By stacking transistors on each nanowire, simple NAND or NOR gate can be built as functional logic gate similarly with the elementary NAND gate in Skybridge fabric (see chapter4). These nanowires can be called logic nanowires. In order to link these logic nanowires for carrying Input/Output signals between cascaded gates, building signal nanowires for routing is necessary. Each signal nanowire is built following coaxial structure with two metal layers and one dielectrics layer for routing. And two adjacent routing layers are isolated by a dioxide layer. Figure. 3.4 shows the structure of the coaxial routing structure.

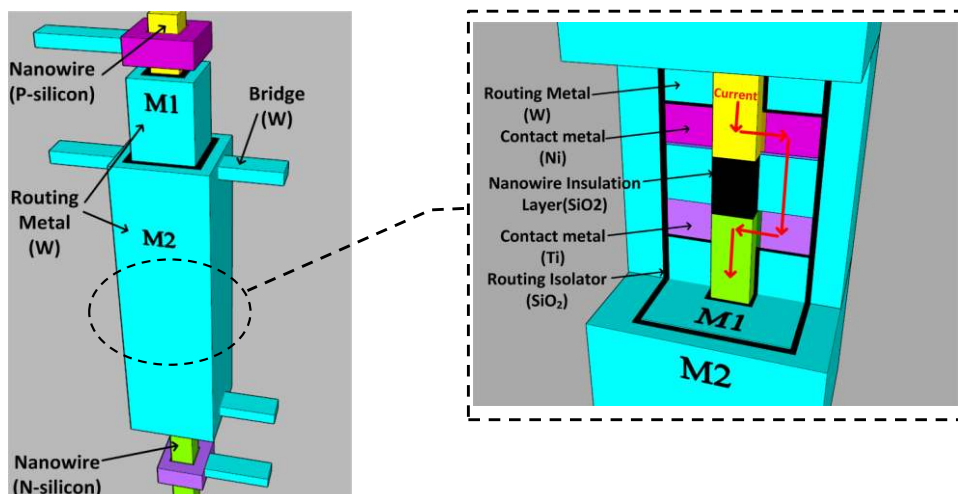

Figure.3.5 Coaxial routing structure and bypass routing layer

The inner dielectrics layer consisted by dual-doped nanowire is not conductive

because initially we insert the silicon dioxide layer for isolating p-type silicon from n-type silicon region. In order to maintain its conductivity, an outer routing layer is designed to form low resistance Ohmic contact conducting signal to bypass the isolation layer.

3.2.4 Ohmic contact and bridge

Logic nanowires and signal nanowires are the fundamental blocks of 3-D fabric. In order to achieve its functionality, it is important to build connection between logic nanowire and signal nanowire enabling high degree connectivity. Based on this purpose, low resistance contact is applied to conduct signals between heavily doped silicon and metal. Due to constraints in wafer masking in current CMOS technology, contacts are built with uniform material, tungsten [12], which forms low-resistance contact with p-type doped silicon but high-resistance contact with n-type silicon. Nevertheless, in our approach, distinct Ohmic contacts are constructed separately layer by layer following bottom-up architecture. In this way, we can form low-resistance Ohmic contact for n- and p- types of doped silicon respectively. The structure and used materials of these two Ohmic contacts is shown in Figure. 3.5. We choose nickel for p-type silicon nanowire Ohmic contact and titanium for n-type nanowire. Each of these two metal have proper workfunctions for the formation of low Schottky Barrier to achieve low resistance [13][14]. A thin titanium nitride layer in the p-type nanowire Ohmic contact is used for avoiding the reaction between nickel and tungsten [12].

Bridge is another important link for connecting nanowires. The function of Ohmic

contact is to conduct the signal between doped silicon and metal with low resistance, while the feature of bridge is to carry signals between Ohmic contacts. As shown in Figure. 3.5, tungsten is used as the material to format the bridges because it has good adhesion ability with titanium. The bridge can be built through material deposition technology as people presented in [14].

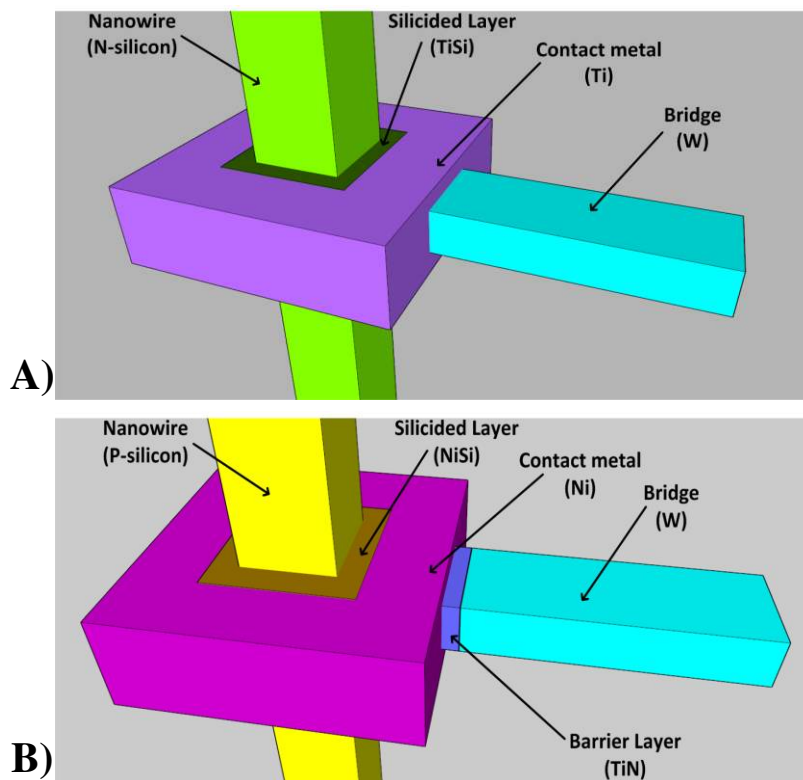

Figure.3.6 Ohmic contact for n-type silicon: A) Ohmic contact on n-type nanowire and B) Ohmic contact on p-type nanowire

3.3 Chapter Summary

In this chapter, we showed the core components of NP-Dynamic-Skybridge fabric and how we extended the basic 3-D concepts to build a new world of 3-D integrated circuits. Based on the fundamental components we introduced in this chapter, the elementary circuits will be demonstrated in next chapter to explain how these elementary circuits can eliminate some of the challenges in Skybridge fabric.

CHAPTER 4

ELEMENTARY CIRCUITS

As we mentioned in Chapter 2, Skybridge fabric requires complicated control clock system due to monotonicity problem in cascaded n-type dynamic logics. Moreover, logical expressions are limited to NAND or AND-of-NAND based implementations. Furthermore, for Skybridge's large-scale circuits, the used dynamic circuit style requires cascaded stages to be micro-pipelined, which results in a large number of buffers causing significant overhead. In this chapter, we show how to achieve diverse implementations for a given logic expression in NP-Dynamic Skybridge fabric and how to build compact elementary circuits by incorporating both n-type and p-type transistors based on the core components we discussed in last chapter.

4.1 Logic Nanowire

Logic nanowire is the core building block which is used to implement elementary logics. In Skybridge fabric, stacking n-type transistors vertically on nanowire is the fundamental way to build elementary 3-D NAND gate. By connecting output nodes of these NAND gates together, compound gate logic AND-of-NANDs can be implemented. In our approach, through stacking n- and p- type transistors on dual-doped nanowire (see chapter 3), both NAND and NOR gates can be built on one nanowire. Figure. 4.1 shows the NAND and NOR 3-D layouts. Compared with the same types of gates in Skybridge fabric, these elementary gates built in NP-Dynamic Skybridge fabric have more compact implementations. For example, building a

5-input NOR gate requires five 1-input NAND gates, and the outputs of these five NAND gates are connected to format AND of NANDs gate logic. This critical characteristic drives compact interconnection for circuits routing and results in improved power and density.

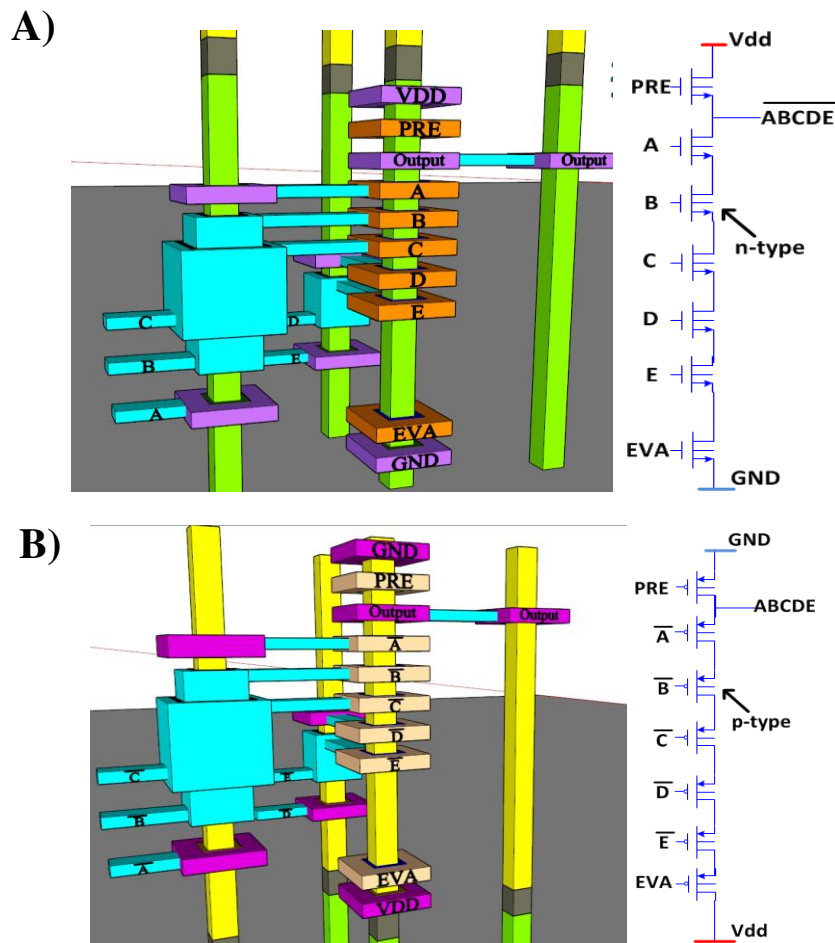

Figure.4.1 NAND gate and NOR gate in NP-Dynamic-Skybridge fabric: A) NAND gate with five n-type transistors stacked on n-type nanowire and B) NOR gate with five p-type transistors stacked on p-type nanowire

4.2 Compound Gate

In Skybridge fabric, by connecting the outputs of NAND gates together, people build AND-of-NANDs compound gate logic. In our approach, besides NAND gate, a NOR gate can also be built by stacking p-type transistors on one nanowire. Through

connecting the outputs of NOR gates, we can implement another kind of gate logic, OR-of-NOR logic. Figure. 4.2 shows the implementation of a XOR gate by both AND-of-NANDs and OR-of-NORs logic. It is obvious that NP-Dynamic Skybridge has better logic flexibility which helps us to achieve diverse ways to implement a given logic.

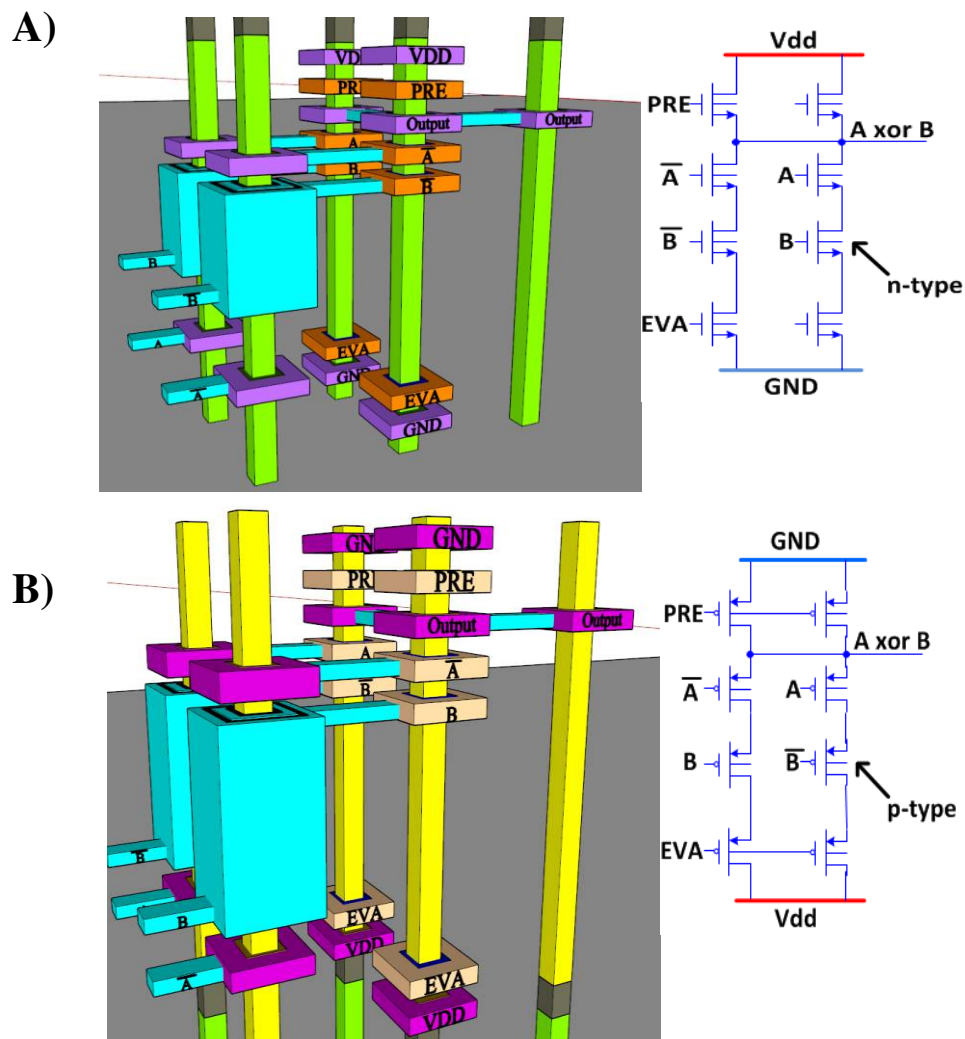

Figure.4.2 XOR gate layout: A) AND-of-NANDs implementation and B) OR-of-NORs implementation

4.3 Cascaded Gates

Cascading logic gates is an important way to implement complicated functions in integrated circuits design. Since single large gate with complicated logic usually has

high delay, a given implemented is usually implemented by several small gates, and each gate's input ports are gated by previous gate's output. In this way, the complicated logic expressions are implemented by considering the tradeoff between transistors' count and performance. Skybridge fabric requires complex control clock system because the separately evaluated stages need corresponding multiple sets of precharge and evaluate control clocks as we discussed in chapter 2. However, in the fabric of NP-dynamic-Skybridge, two cascaded stages are built with two different types of dynamic logics (n- and p- type). Such a scheme avoids the typical monotonicity problem of cascaded dynamic logic gates, and all the cascaded stages of a given circuit are evaluated in the same clock period by uniform control clock. Only one set of precharge and evaluate clocks is required, and it simplifies the control clock system design. Figure. 4.3 shows a simple example of cascaded gates and its validation of function.

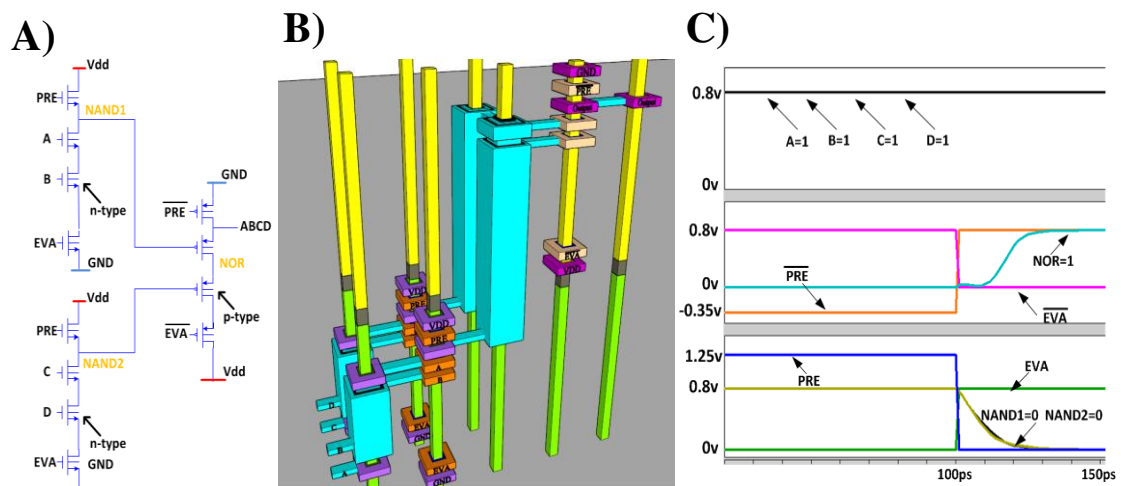

Figure.4.3 Cascaded gates and waveform validation: A) Schematic of cascading NAND and NOR gates and B) Layout of cascaded gates and C) HSPICE simulation waveforms of cascaded gates

4.3 Chapter Summary

In this chapter, we mainly showed how to build the elementary circuits based on the core components of NP-Dynamic-Skybridge fabric. Further explanations of diversity and flexibility in logic implementations were presented. It is a critical contribution to drive compact circuits design. Additionally, the scheme of cascading two different types' dynamic logics effectively reduces the difficulty of control clock system's design. In next chapter, we will provide the benchmarking results of the proposed fabric and discuss about its potential in power and performance improvement.

CHAPTER 5

BENCHMARKING AND RESULTS

Benchmarking is a quantitative approach to show whether the proposed approach has potential in improving circuits' key metrics. In this chapter, we detail on the benchmarking methodology and make analysis for benchmarking results of an arithmetic circuit, 4-bit carry look-ahead adder (CLA) [15]. Based on the core components and elementary circuits we had discussed in chapter 3 and 4, the arithmetic circuit was built by cascading elementary circuits with a micro pipelined circuit style. And the layout was built following vertically bottom-up architecture style which includes fundamental nanowire array, contacts, bridge and devices. After preparation of schematic and layout [1], we made initial evaluation for the benchmark to quantify the improvement of the proposed fabric over Skybridge fabric.

5.1 Benchmarking Methodology

Comprehensive methodologies, from the material layer to system, were developed to evaluate the potential of Skybridge vs. CMOS. All circuit simulations followed a bottom-up simulation methodology that includes device physics, 3-D interconnect parasitics, 3-D circuit style, and benchmarking power/performance.

- (i) *TCAD device simulation*: Process simulation was done to create the device structure emulating the actual process flow. Process parameters (e.g., implantation dosage, anneal temperature, etc.) used in this simulation were taken from previous experimental work on junctionless transistor [1]. Process

simulated structure was then used in Device simulations to characterize device behavior. Detailed considerations were taken to account for confined device geometry, nanoscale channel length, surface and secondary scattering effects.

- (ii) **Circuit Simulation:** The TCAD simulated device characteristics were used to generate an HSPICE compatible behavioral device model. Circuit mapping into Skybridge fabric and interconnection followed similar fabric's design rules and guidelines, which had been proposed in Skybridge fabric[1]. And based on the circuit's 3-D layout, capacitance calculations for Coaxial routing structures were according to the methodology in[16], and resistance calculations were according to the ASU PTM interconnect model [16]. The PTM model [16] was also used for metal routing RC and coupling capacitance calculations.

5.2 Benchmarking Results and Scalability

5.2.1 Benchmarking of 4-bit Carry Look-Ahead Adder

CLA is well-known parallel adder for fast computation. It consists of propagate-and-generate, carry, buffer and summation blocks. The propagate-and-generate block is used to produce intermediate signals P_i and G_i (where $i = 0$ to 3), which are used for calculating Sum and Carry respectively; the logic expressions used are $P_i = (A_i \oplus B_i)$, $G_i = A_i \cdot B_i$. The carry block is used to compute intermediate carry signals and final carry output. The logic expression for carry generation is $C_i = G_{i-1} + P_{i-1} \cdot C_{i-1}$, where 'i' is from 1 to 4. The buffer block is used to buffer a signal and maintain signal integrity. The sum block generates the final sum output using the intermediate P_i and C_i signals; the logic expression is

$$S_i = A_i \oplus B_i \oplus C_i = P_i \oplus C_i.$$

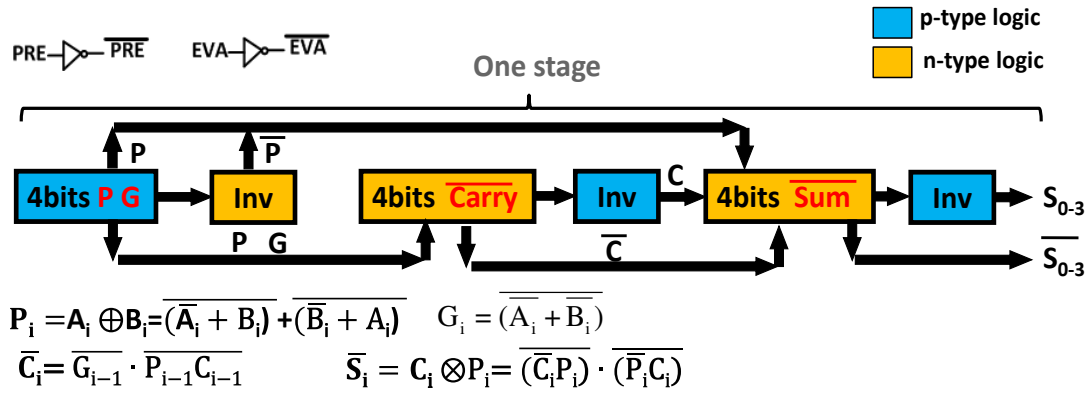

Figure.5.1 Block diagram of 4-bit CLA

A block diagram of a 4-bit CLA is shown in Figure. 5.1; The CLA is implemented with combinational-rail logic, and every two cascaded stages are implemented by two different types (n- and p-) of logics. In order to implement the CLA with single-rail logic style, each stage is followed by inverters which generate complementary signals.

Such a scheme reduces the number of stages to one compared with three stages' implementation in Skybridge fabric. In addition, because the circuit's operation is static-like and all stages are operated in one clock period, it does not require any buffers for storing minterms between stages. This results in significant reduction of buffers which causes large overhead in Skybridge fabric.

5.2.2 Results of Benchmarking

Table. 5.1 shows the evaluation results of 4-bit carry look-ahead adder. Obviously, NP-Dynamic-Skybridge has tremendous benefits in key metrics over Skybridge fabric. NP-Dynamic-Skybridge achieves 4x latency benefits over Original SB single-rail implementation and it has at least 17% power/throughput benefit. In addition, over 2x

density improvement is achieved in NP-Dynamic-Skybridge because of its single-rail static-like logic implementation with reduction of buffers. However, there is degradation in throughput due to less pipelining stages and longer clock period for evaluation.

Table.5.1 Evaluation results of 4-bit CLA

4-bit CLA	Latency (ps)	Power (uW)	Area(um²)	Throughput	Throughput/Power(Ops/J)
Original SB (Dual-rail)	96	22.1	0.76	10.4E+9	4.7E+15
Original SB (Single-rail)	192	13.4	0.41	7.8E+9	5.8E+15
NP-Dynamic-SB	50	9.5	0.36	6.6E+9	6.9E+15

5.3 Chapter Summary

This chapter mainly presented the initial evaluation results of benchmarking circuit for NP-Dynamic-Skybridge fabric. It showed how much benefit in key metrics we can achieve compared with Skybridge fabric. And we initially proved our proposed approach is a good extension of Skybridge 3-D fabric.

In next section, we will present the proposed future work and what we should do to make the new fabric to be more mature.

CHAPTER 6

FAN-IN ANALYSIS AND SCALABILITY

High fan-in logic is a well-known driver for compact circuit designs. Since they have fewer transistors and interconnects, they are advantageous for improving both density and power consumption. However, high fan-in circuits are not widely used due to their detrimental impact on performance compared to low fan-in cascaded designs. The performance degradation is particularly severe in CMOS, where the circuit style requires complementary devices, and the devices have to be differently sized, which adds to load capacitance, and thus lowers the performance. However, in Skybridge fabric, the logic is implemented with dynamic circuit style and only single type uniform transistors are used for compact 3-D layout design, which helps to reduce output load capacitance of each gate and allow high fan-in gate design.

In this chapter, we try to show, in NP-Dynamic Skybridge, high fan-in gate can also be used due to its similar dynamic circuit style with Skybridge. In addition, the scalability, which indicates the tendency of key metrics along with circuits' scale going up, is studied by benchmarking 8-bit CLA.

6.1 Fan-in Analysis

6.1.1 Evaluation Methodology

In order to evaluate the feasibility of high fan-in gate logic in NP-Dynamic Skybridge, we carried out the fan-in sensitivity analysis using NAND gate (series of n-type transistors) and NOR gate (series of p-type transistors) as circuit samples.

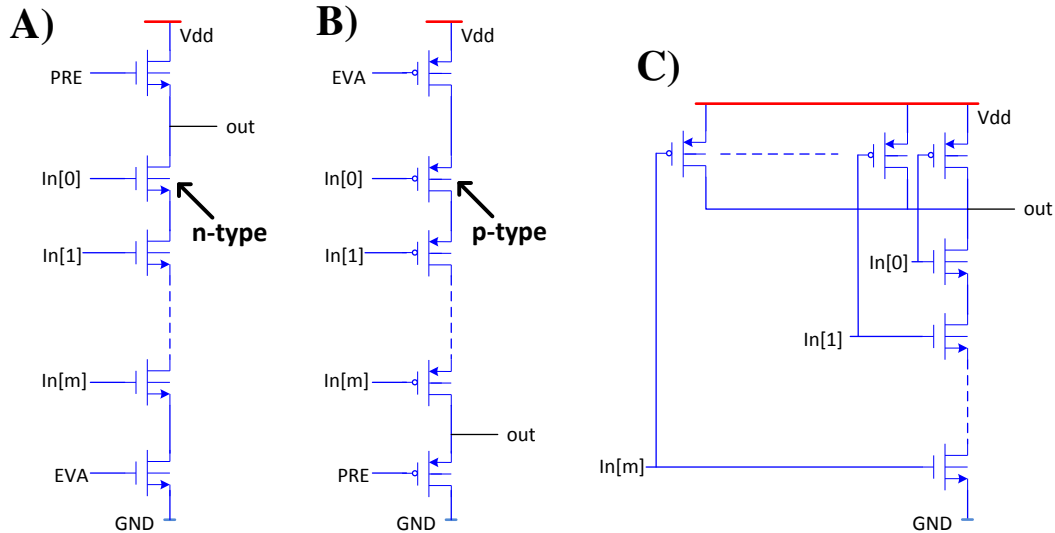

Figure.6.1 **Example gate for fan-in sensitivity analysis:** A) Schematic of NAND gate in NP-dynamic Skybridge (same as Skybridge) and B) Schematic of NOR gate in NP-dynamic Skybridge and C) Schematic of NAND gate in CMOS design

Figure.6.1A and Figure.6.1B show the schematic of elementary NAND and NOR gates respectively. TCAD generated V-GAA Junctionless device model (see chapter 3) were used to build circuit's netlist for HPSICE simulation,. Similarly, for CMOS baseline, equivalent NAND gate circuit (Figure. 6.1C) was built by using 16nm tri-gate high-performance PTM device models. The output node of both CMOS and NP-Dynamic Skybridge gates were connected with load capacitances which are equivalent to fan-out of 4 inverters in respective designs. The worst-case delay was measured in the valid falling edge (90%VDD to 10%VDD) of the output node.

6.1.2 Fan-in Sensitivity Analysis

After doing circuits simulation with the methodology discussed in last section, the fan-in sensitivity for 16nm CMOS, Skybridge and NP-Dynamic Skybridge are carried out and shown in Figure. 6.2. Obviously, as fan-in number goes up, the normalized gate delay of NP-Dynamic Skybridge has similar increasing tendency as Skybridge. This is mainly determined by the dynamic circuit style used in NP-Dynamic

Skybridge. By contrast, the CMOS NAND gate is built by using static logic style as shown in Figure. 6.1C which means as fan-in number goes up, the load capacitance of

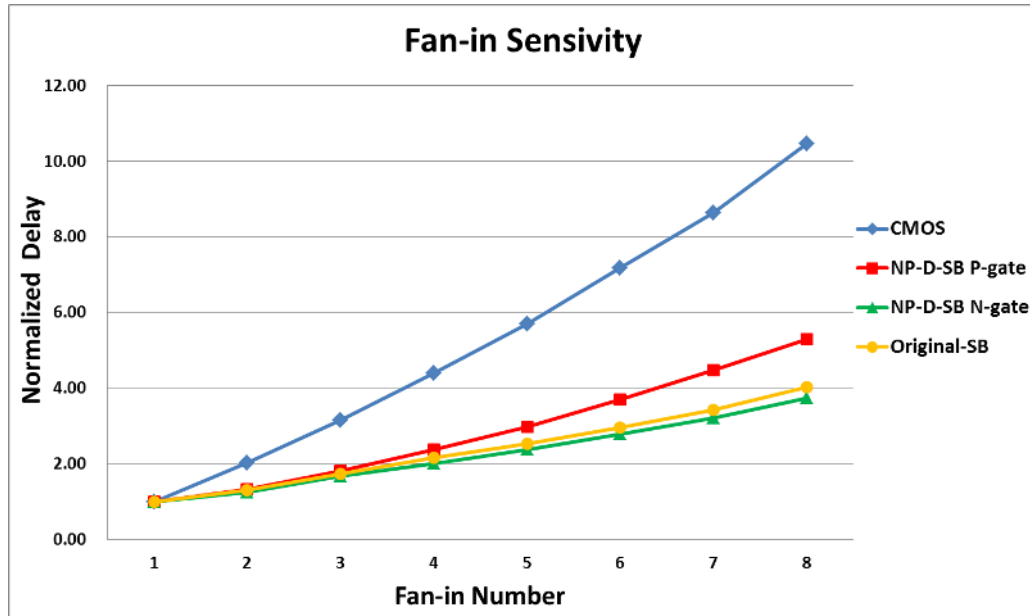

Figure.6.2 Fan-in sensitivity curves

output node increases linearly due to more and more drain capacitances from parallel p-type transistors of pull-up network. Therefore, for CMOS static circuits, the gate delay suffer from both increased output load capacitance and raised total resistance in pull-down network, which results in quadratic increasing of CMOS gate delay as fan-in number goes up. Both Skybridge and NP-Dynamic Skybridge use dynamic circuit style to avoid the increased load capacitance from pull-up network and thus achieve linear fan-in sensitivity.

Generally, for standard CMOS design, people limit the max fan-in to 4 due to its high sensitivity to gate delay. As shown in Figure. 6.3, we determine the max fan-in number of NAND and NOR gate based on similar normalized delay used for CMOS NAND gate's fan-in constrain.

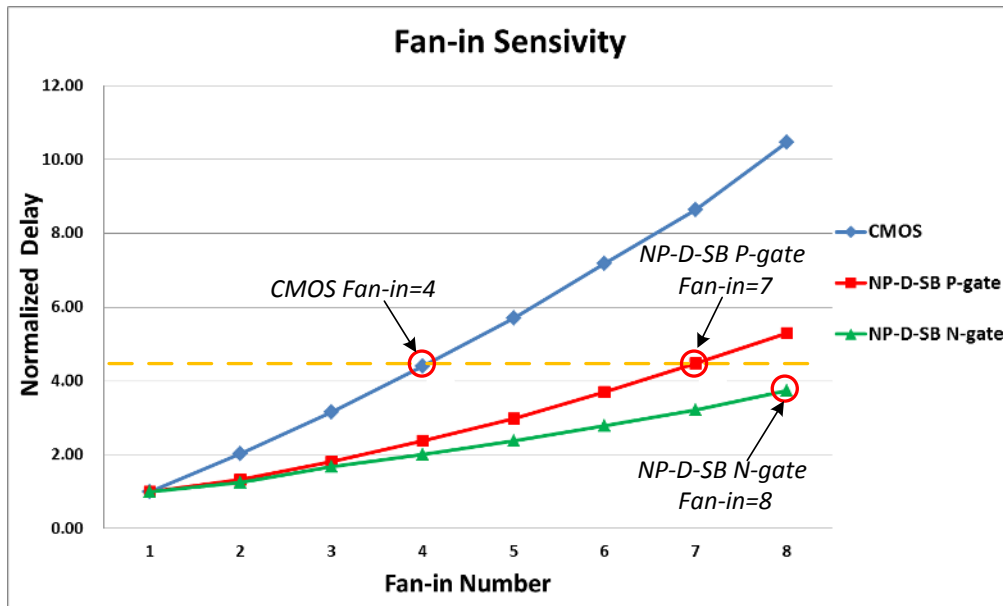

Figure.6.3 Determination for maximum fan-in for NP-Dynamic

6.2 Scalability and Larger Scale Benchmarking

6.2.1 Scalability Study

High fan-in gate drives compact layout design which results in benefits of power and performance. As circuits' scale goes up, Skybridge fabric achieves more benefits in power and throughput compared with conventional 2-D CMOS fabric by using high fan-in gates. As we discussed in last chapter, in NP-Dynamic Skybridge, we can also implement logics by using high fan-in gate. So this helps to keep achieving benefits in key metrics over conventional CMOS for the large scale benchmarks.

6.2.2 Benchmarking for Larger Scale Design

We show the scalability of NP-Dynamic-fabric by benchmarking larger scale circuit. We built 8-bit CLA and compared its benchmarking results with previous 4-bit CLA's benchmarking results. As shown in the Figure. 6.4, when scaling up from 4-bit to 8-bit, the improvements in latency and power of NP-Dynamic fabric rises up due to

more reduction of buffers. And also there is less degradation in throughput because in NP-Dynamic-Skybridge fabric, the throughput is determined by total evaluation time of all stages but not the delay of critical stage which increases linearly as circuit's scale goes up.

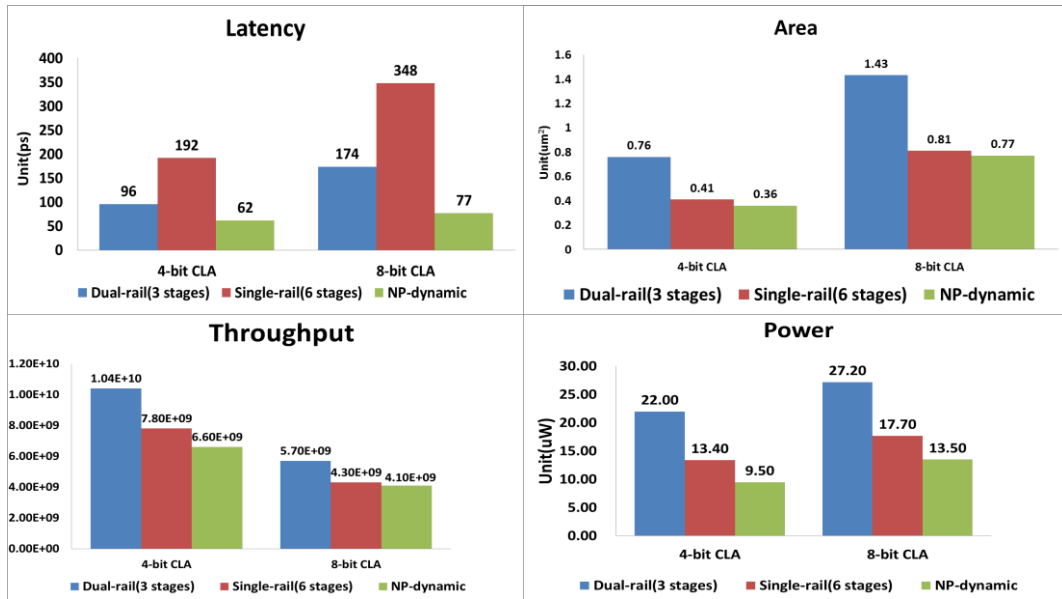

Figure.6.4 Evaluation results of 4-bit and 8-bit CLAs

6.3 Chapter Summary

This chapter mainly presented the logic implementations by using high fan-in gate in NP-Skybridge fabric similarly with Skybridge fabric. In addition, by benchmarking larger scale circuits, 8-bit CLA, we showed that the proposed new fabric can achieve improvement in key metrics as Skybridge when using high fan-in gate. However, in Skybridge fabric, any given circuit is divided into several micro pipelined stages, so it has relatively higher throughput than the circuit with NP-Dynamic Skybridge fabric. In next chapter, a 4-bit microprocessor benchmark will be presented which has optimized pipelining scheme for improving throughput.

CHAPTER 7

WIRE STREAM PROCESSOR BENCHMARKING

In this chapter, a 4-bit wire stream processor (WISP-4) [22] is shown. This microprocessor is built at transistor level, and functionally verified at the circuit level. The WISP-4 processor design uses a load-store architecture, which is common in modern RISC processor designs. And it is a five-stage design and composed of program counter (PC), read-only-memory (ROM), register file (REG), arithmetic logic unit (ALU) and write back (WB). Design of all logic and memory circuits for processor follow the NP-Dynamic Skybridge's circuit styles (see Chapter 4). Circuit placements and layouts are in accordance to the NP-Dynamic Skybridge fabric design rules and guidelines (see Chapter 3). Additionally, a new pipelining scheme is proposed. Compared with the pipelining scheme in Skybridge fabric, the operation frequency of each stage increases and thus the computation throughput is improved.

Using the bottom-up evaluation method mentioned in chapter 5, simulations were carried out to validate WISP-4 design and show its potential against equivalent Skybridge and CMOS implementations. The benchmarking results show that NP-Dynamic has advantageous benefits in key metrics over Skybridge and CMOS for large scale circuits.

7.1 Optimized Pipelining scheme

7.1.1 Pipelining Scheme in Skybridge Fabric

In Skybridge fabric, dynamic circuit style is used to implement logics and all logics

gates are built with n-type transistors. In order to avoid typical monotonicity problem in cascaded n-type logics, the whole pipeline is built with several micro stages and each stage's logic evaluation is controlled by one single clock. This results in successive and separately evaluated stages and also each stage has one phase holding output value for next stage's evaluation. Therefore, each stage has totally three clocking phases 'precharge', 'evaluate' and 'hold'. For the single-rail design, inverters are inserted between each two stages to generate complementary signals. The stage, which provides true output signals, thus costs one more hold phase to wait for the generation of complementary signals in the followed inverters. So this is a four phases' pipeline design with phases 'precharge', 'evaluation', 'hold1' and 'hold2'. The timing of dual-rail (three phases) and single-rail (four phases) pipeline is shown in Figure.

7.1.

A)

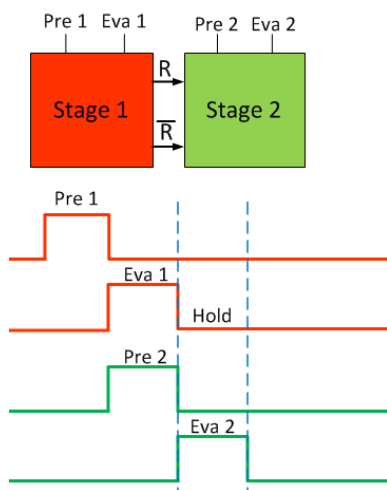

B)

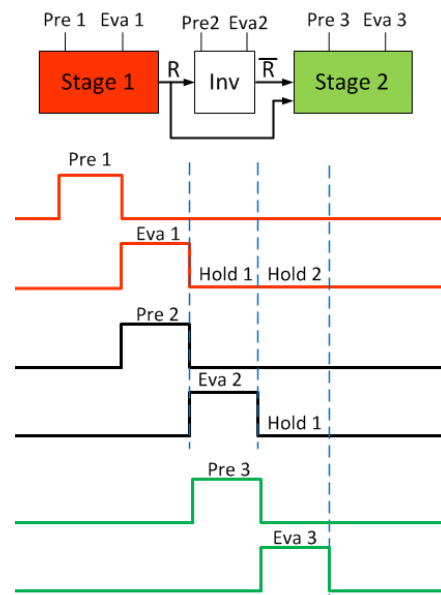

Figure.7.1 Pipelining Scheme of Skybridge: A) Timing of pipeline of single-rail design and B) Timing of pipeline of dual-rail design

7.1.2 Proposed Pipelining Scheme of NP-Dynamic Skybridge

In order to improve throughput, we propose a new pipelining scheme. Here, each stage is executed with two phases, 'precharge' and 'evaluate', which results in more frequent operations in each stage. The latches which are specified for dynamic circuits' pipeline [23] are used between each two stages to store output results. The circuit design is shown in Figure. 7.2. During the evaluation phase, the latches are enabled by signal {Eva Evab} and the output results go through latches. After the evaluation phase, the latches are turned off and hold the output results for the evaluation of next stage. Therefore, for each stage, after evaluation, it can be precharge again immediately without waiting and holding results for its next stage. The timing and circuits is shown in Figure. 7.2 in detail.

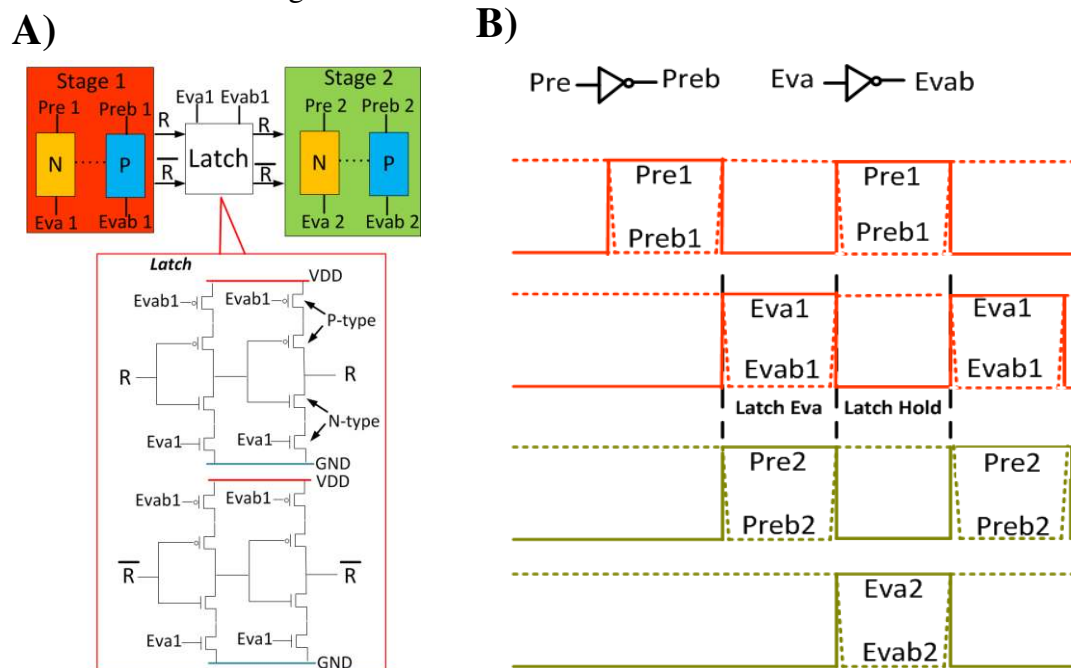

Figure.7.2 **Pipelining Scheme of NP-Dynamic Skybridge:** A) Schematic design of latch and B) Timing of pipeline of NP-Dynamic Skybridge

7.1.3 Timing and Clock Optimization

Based the optimized pipelining scheme, the initial timing design for WISP-4

pipeline is shown in Figure. 7.3. Each stage is controlled by either clock set ‘pre1&eva1’ or ‘pre2&eva2’, and two cascaded stages are controlled by different clock sets.

However, using two separated clock sets is contrary to the purpose of proposed NP-Dynamic Skybridge fabric. As we discussed in chapter 3, in Skybridge fabric, due to functional monotonicity problem in cascaded n-type dynamic logics, multiple sets of ‘precharge and evaluate’ clocks are used to synchronous and control the separated stages of the pipeline, which results in complex clock system design. And in the proposed NP-Dynamic Skybridge fabric, functional monotonicity problem can be avoided by cascading two types (n and p) of logics to implement circuit function. Only one set of clock (‘precharge’ and ‘evaluate’) is used to control the all stages of any given circuit. In order to simplify the clock system, we do further optimization of timing as shown in Figure. 7.3. Noticeably, the clock pre1 overlaps eva2, and similarly eval1 overlaps pre1. By compressing the same clocks together, we simplified the clock system to one clock set ‘CLK1 and CLK2’ as shown in Figure. 7.4 and Figure. 7.5.

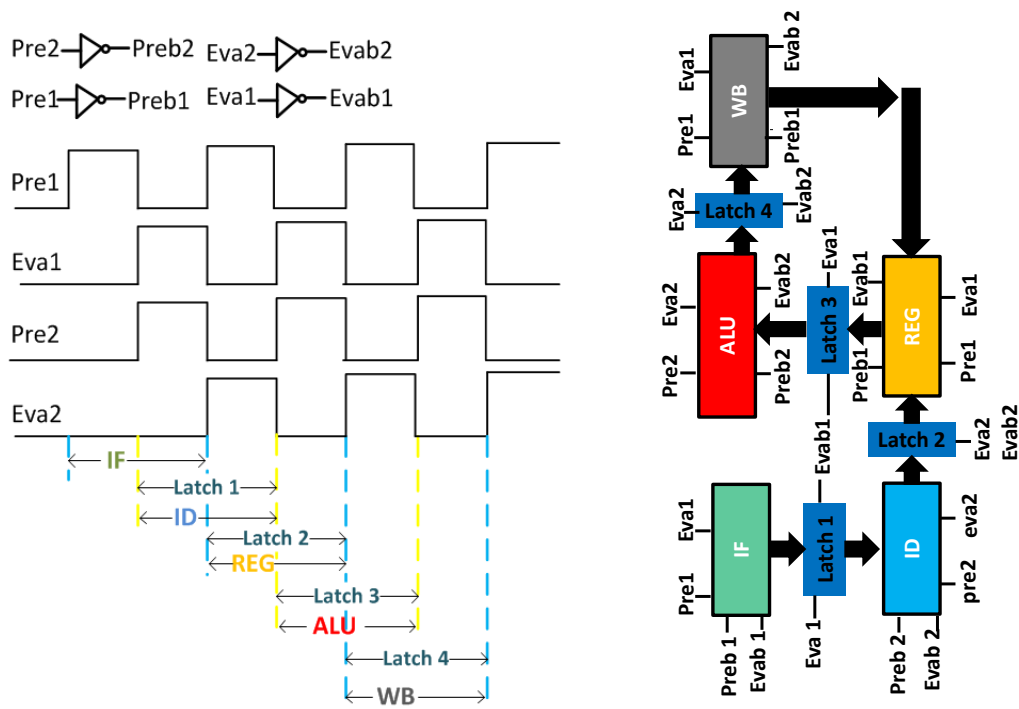

Figure.7.3 Timing of NP-Dynamic Skybridge

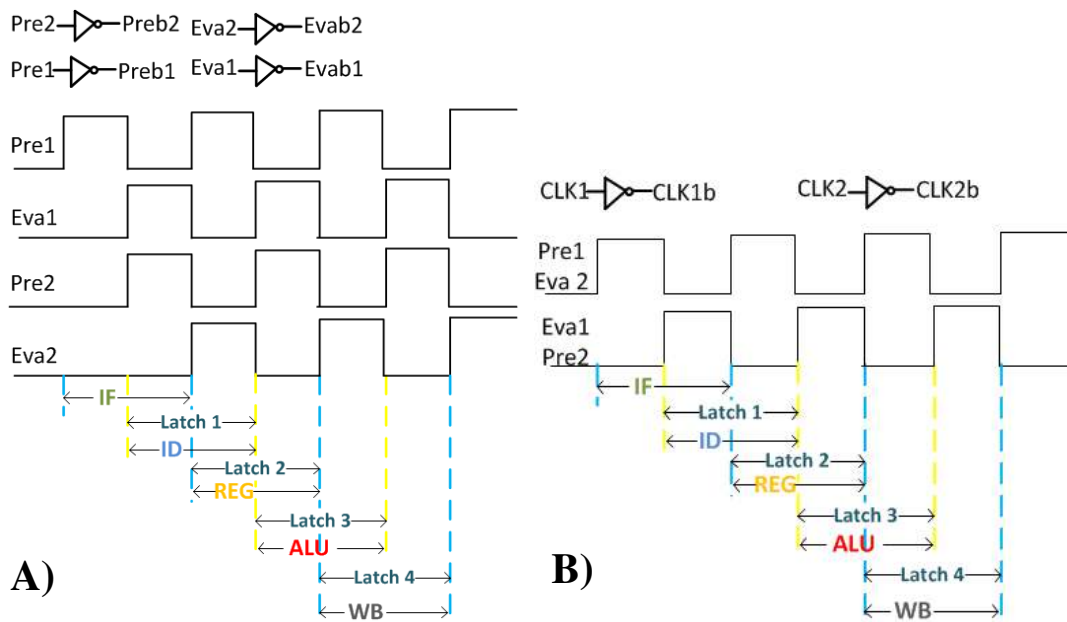

Figure.7.4 Timing of NP-Dynamic Skybridge: A) Pipeline timing with two clock sets and B) Optimized pipeline timing with one clock set

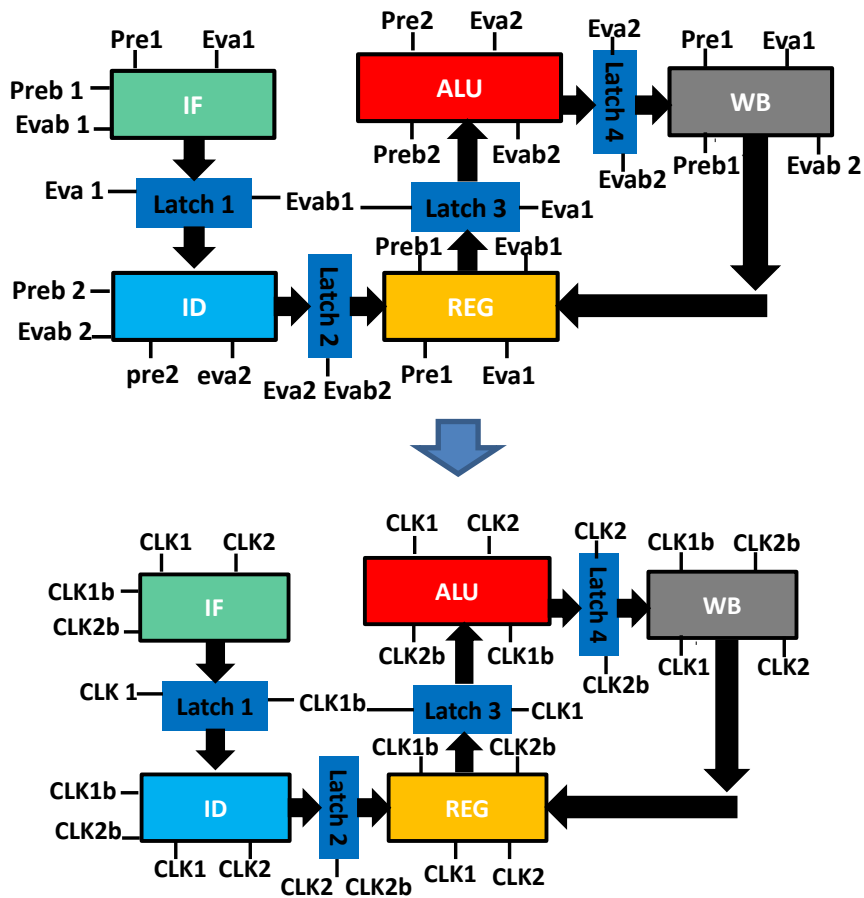

Figure.7.5 Clock Optimization

7.2 WISP-4 Benchmarking

7.2.1 WISP-4 Circuit and Architecture

The architecture of WISP-4 is shown in Figure. 7.6. It has five pipeline stages: Instruction Fetch, Decode, Register Access, Execute and Write Back. During Instruction Fetch, an instruction is fetched from ROM and is fed to instruction decoder. In Instruction Decode, the fetched instruction is decoded to generate control signals, and to buffer the register addresses and data. In the next stage, buffered data is stored in register file and prepared for sequential execution in the Execute stage. After ALU operations in the Execute stage, results are stored in the register file during

Write Back. The synchronization of pipeline stages is maintained through micro pipelining of logic blocks at each stage; this is possible, since all logic block implementation is through the Skybridge logic style, which uses clock signals as control inputs.

The instruction fetch unit consists of a program counter (PC) and a ROM. The PC is a 4-bit binary up counter that is used to continuously increment the instruction address every clock cycle. This implementation uses a 4-bit CLA; one of its inputs is constant '1', and another is the result of previous calculation. The result of PC is fed to a 4:16 decoder to select one of the 16 rows from the instruction ROM. The ROM stores a set of instructions to be executed and has a total capacity of 16x9bits in this prototype. The output of ROM is a 9-bit instruction and contains 3-bit operation instruction (opcode), two 2-bit source/destination register addresses or 4-bit data. Circuit-level implementation of these processor units follows the Skybridge circuit style. Both Compound and cascaded dynamic logic styles are combined for efficient implementations. 4-bit CLA and HSPICE validations were shown in Chapter 5; in this section we show the core supporting circuits.

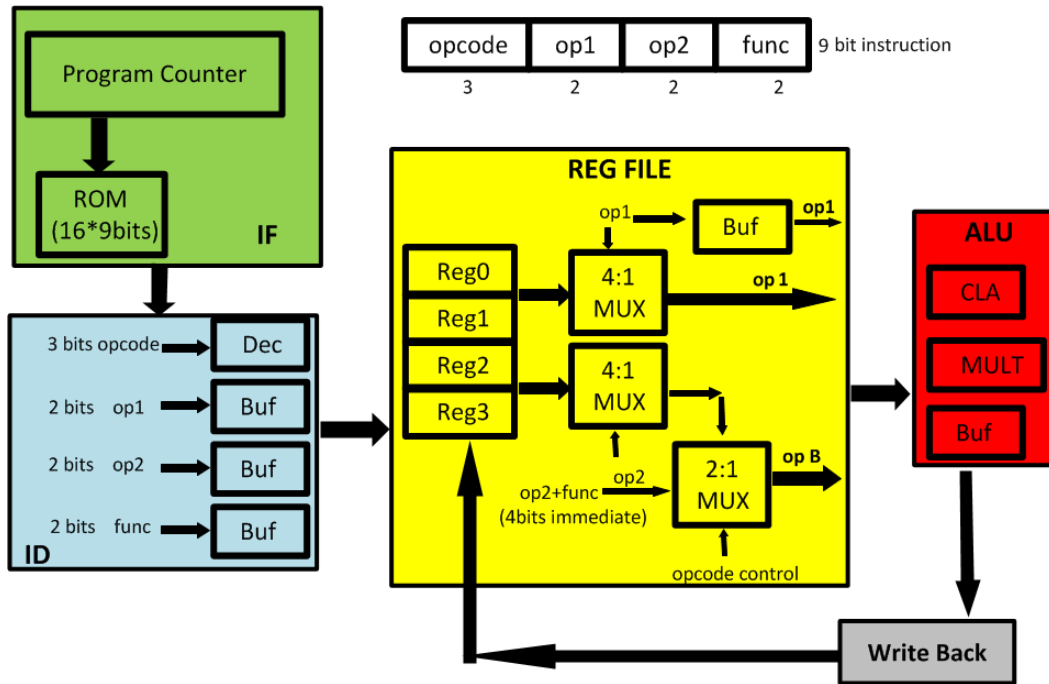

Figure.7.6 Architecture Block Diagram

7.2.2 Benchmarking Results

The WISP-4 benchmark was built in transistor-level based on the architecture we present in last section. By following the methodology we discussed in chapter 5, we did RC extraction from layout and wrote circuit netlist with extracted RC information for HSPICE simulation. Figure. 7.6 shows the benchmarking results of NP-Dynamic Skybridge, Skybridge and 16nm CMOS fabric. Since the pipelining scheme is optimized to two phases' timing for each stage, the NP-Dynamic Skybridge achieves 1.1x benefits in throughput over Skybridge Fabric. For the power and throughput/power, which are related with circuits' total interconnect capacitance, NP-Dynamic Skybridge fabric shows at most x1.5 improvement due to its single-rail circuits' implementations. In addition, NP-Dynamic Skybridge has x2 better density because of its single-rail circuit design and reduced overhead of buffers as we

discussed in chapter 2.



Figure.7.7 WISP-4 Benchmarking Results

7.3 Chapter Summary

In this chapter, we mainly showed how we implement WISP-4 benchmark with optimized pipelining scheme and the benchmarking results. Based on the benchmarking results, it was shown that NP-Dynamic Skybridge has benefits in key metrics over Skybridge fabric. Additionally, NP-Dynamic-Skybridge processor was implemented with simplified clock system in comparison to Skybridge. Therefore, it can be concluded that the proposed new fabric carries out a good extension of Skybridge 3-D fabric and makes contribution to 3-D integrated circuits.

BIBLIOGRAPHY

- [1] M. Rahman, S. Khasanvis, J. Shi, M. Li, C. A. Moritz. "Skybridge: 3-D Integrated Circuit Technology Alternative to CMOS." *Nature Nanotechnology* Under Review, 2014.
- [2] H. Iwai. "Roadmap for 22 nm and beyond." *INFOS* 86 (2009): 1520-1528.
- [3] K. Kim, K. K. Das, R. V. Joshi, C. Chuang. "Nanoscale CMOS Circuit Leakage Power Reduction by Double-Gate Device." *ISLPED*, 2004, 102-107.
- [4] J. Warnock. "Circuit Design Challenges at the 14nm Technology Node." *DAC*, 2011, 464-467.
- [5] K. E. Moselund, P. Dobrosz*, S. Olsen*, V. Pott, L. De Michielis, D. Tsamados, D. Bouvet, A. O'Neill* and A. M. Ionescu. "Bended Gate-All-Around Nanowire MOSFET: a device with enhanced carrier mobility due to oxidation-induced tensile stress." *IEDM*, 2007, 191-194.
- [6] N.I Weste, D. Harris,. *CMOS VLSI Design: A Circuits and Systems Perspective*, Boston: ADDISON WESLEY, 2011.
- [7] P. Batude, M. Vinet, A. Pouydebasque, C. Le Royer, B. Previtali, C. Tabone, J.-M. Hartmann, L. Sanchez, L. Baud, V. Carron, A. Toffoli, F. Allain, V. Mazzocchi, D. Lafond, O. Thomas, O. Cueto, N. Bouzaida, D. Fleury, A. Amara, S. Deleonibus and O. Faynot. "Advances in 3D CMOS Sequential Integration." *IEDM*, 2009.
- [8] P. Batude, M. Vinet, C. Xu, B. Previtali, C. Tabone, C. Le Royer, L. Sanchez, L. Baud, L. Brunet, A. Toffoli, F. Allain, D. Lafond, F. Aussenac, O. Thomas, T. Poiroux and O. Faynot. "Demonstration of low temperature 3D sequential FDSOI integration down to 50 nm gate length." *VLSIT*, 2011, 158-159.
- [9] A. Kranti, R. Yan, C.-W. Lee, I. Ferain, R. Yu, N. Dehdashti Akhavan, P. Razavi, JP Colinge. "Junctionless nanowire transistor (JNT): Properties and design guidelines." *ESSDERC*, 2010, 357-360.
- [10] K. Choi, et.al. "The Effect of Metal Thickness, Overlayer and High-k Surface Treatment on the Effective Work Function of Metal Electrode ." *ESSDERC*, 2005, 101-104.
- [11] P. Jiang, et.al. "Dependence of crystal structure and work function of WN_x films on the nitrogen content." *Applied Physics Letters*, 2006, 122107 -122107 -3.
- [12] C. Hu. *Modern Semiconductor Devices for Integrated Circuits*. N.J: Upper Saddle River, 2010.

- [13] W. B. Nowak, R. Keukelaar, W. Wang, and A. R. Nyaiesh. "Diffusion of nickel through titanium nitride films." *JVST*, 1985, 2242-2245.
- [14] Rosler, R. S., Mendonca , et.al. "Tungsten chemical vapor deposition characteristics using SiH4 in a single wafer system." *JVST*, 1988, 1721-1727.
- [15] Koren, I. *Computer Arithmetic Algorithms*. MA: A. K. Peters, 2002.
- [16] Milovanovic, A. & Koprivica, B. Analysis of square coaxial lines by using Equivalent Electrodes Method. Nonlinear Dynamics and Synchronization (INDS) & 16th Int'l Symposium on Theoretical Electrical Engineering, 2011
- [17] Arizona State University. *PTM-MG device models for 16nm node*, <www.ptm.asu.edu>.
- [18] Y. Taur, Tak H. Ning. *Fundamentals of Modern VLSI Devices*. N.Y: Cambridge University Press, 2009.
- [19] T. Solankia, N. Parmar. "A Review paper: A Comprehensive study of Junctionless transistor." *NCIPET*, 2012.
- [20] Arizona State University. PTM R-C Interconnect models. <<http://ptm.asu.edu/>> (2012)
- [21] E. J. Nowak, I. Aller, et.al.,. "Turning Silicon on Its Edge." *IEEE Circuits and Devices Magazine*, 2004, 20-31.
- [22] C. A. Moritz, T. Wang. "Towards Defect-Tolerant Nanoscale Architectures." *IEEE-NANO*, 2006, 331-334.
- [23] N. F. Goncalves, Hugo. J.De . "NORA: A Racefree Dynamic CMOS Technique for Pipelined Logic Structures" *Solid State Circuits*, 1983.