

REVIEW ARTICLE

Assembly and secretion of hepatic very-low-density lipoprotein

Geoffrey F. GIBBONS

Metabolic Research Laboratory, Nuffield Department of Clinical Medicine, Radcliffe Infirmary, Woodstock Road, Oxford OX2 6HE, U.K.

INTRODUCTION

A major function of metabolic regulation is to ensure an adequate supply of fuel for energy-requiring tissues in the face of large fluctuations in food intake. This is achieved by co-ordination of the storage of carbohydrate and lipid when food consumption is high and mobilization of these stores inter-prandially. During feeding, part of the triacylglycerol laid down in adipose tissue originates in the liver from which it is secreted as very-low-density lipoprotein (VLDL). In the starved state, VLDL triacylglycerol also plays an important role in providing fuel for muscle tissue. In man, the exact contribution from this source is not known but in the rat, 50% of the total lipid energy requirement of muscle tissue during starvation is met by VLDL triacylglycerol [1]. In both the fed and starved states, therefore, hepatic VLDL triacylglycerol makes an important contribution to the maintenance of whole-body energy balance and its production is integrated and co-ordinated with other energy-related metabolic pathways. The means by which this is achieved forms the central theme of this review. An important question to be addressed throughout is the means by which signals resulting from changes in nutritional status alter the rate of assembly and secretion of VLDL particles at the molecular level. In this respect, much attention has been focused on apoprotein B (apo B), the polypeptide which forms the structural framework of the VLDL particle and without which hepatic triacylglycerol secretion is not possible [2,3]. It should be kept in mind, however, that the over-riding physiological purpose of VLDL production is the need to secrete hepatically synthesized triacylglycerol. *A priori* then, it seems likely that under normal conditions changes in the availability of functional hepatic apo B are secondary to, or are co-ordinated with, changes in the availability of triacylglycerol destined for secretion. Another objective of this review is to examine how this is achieved and how this relationship breaks down in certain pathological states such as diabetes, obesity, and alcoholism. Finally, plasma triacylglycerol is the most efficient means of energy transport between organs at concentrations which are well-tolerated by the body tissues. This review will also deal with the source of the triacylglycerol utilized for hepatic VLDL synthesis and how this is affected by different nutritional and pathological states.

INTRACELLULAR ASSEMBLY OF VLDL

Nascent VLDL secreted by the liver consists of globular particles with diameters ranging between 25 and 75 nm [4]. The bulk of the hydrophobic core of the particle consists of triacylglycerol with smaller amounts of cholesteryl ester. Thermodynamic stability is provided by the presence of a relatively hydrophilic shell consisting of a monolayer of phospholipid and

non-esterified cholesterol. The major structural framework of the particle, however, is provided by a polypeptide, apo B, which is large enough to encircle the particle interacting both with the surface lipids and with the hydrophobic core [5].

General principles of protein secretion

The general structure of the protein secretory apparatus was established by 1974, mainly by Palade and his co-workers [6] and, more recently, the detailed morphology has been established (for reviews see [7–10]). Transport of proteins through the secretory apparatus involves the budding-off of one organelle and fusion of the resultant transport vesicle to the next organelle in the sequence (Fig. 1).

Targeting of secretory proteins to the ER is achieved by the translation of a signal-sequence from the appropriate mRNA on a cytosolic ribosome. Binding of the signal sequence to a signal-recognition particle (SRP) which recognizes a so-called 'docking protein' on the ER permits the targeting of the whole complex to the cytosolic face of this organelle. Following cleavage of the signal peptide, translocation then occurs simultaneously with translation via a transient channel in the ER membrane [10]. In the case of apo B the 27-residue signal sequence occurs at the *N*-terminus of the molecule, starting with a methionine residue. There is evidence that apo B is not completely translocated during translation and that it remains membrane-bound for a considerable period during its passage through the secretory apparatus. This may be of importance in maintaining a particular conformation of apo B required both for triacylglycerol binding and for the assembly of 'signal-patches' [9] which interact with receptors in the secretory apparatus [11]. It is thought that these interactions determine the intracellular transport rate and the ultimate destination (e.g. membrane, lysosome, secretory vesicle) of a particular protein.

Biosynthesis and structure of apo B

Earlier disagreements about the size and structure of apo B have now been resolved by the formulation of the complete amino acid sequence deduced by sequence analysis of cDNA clones [5,12–14]. The polypeptide is coded for by a 14.1 kb DNA which produces a 4563-residue amino-acid sequence (including a 27-amino-acid signal peptide) of M_r 514000.

Elucidation of the amino-acid sequence has allowed the prediction of various aspects of secondary and tertiary structure, which has proven invaluable in formulating theories of VLDL assembly [14–16]. For instance, frequent alternation of hydrophilic and hydrophobic sequences, the latter having high probability for β -sheet structure, suggested that apo B interacts with the polar surface of the particle and also dips frequently into the hydrophobic interior, thereby providing numerous anchoring points [14]. Although the hydrophobic sequences of apo B are

Abbreviations used: VLDL, very-low-density lipoprotein; NEFA, non-esterified fatty acids; LDL, low-density lipoprotein; LPL, lipoprotein lipase; apo B, apoprotein B; RER, rough endoplasmic reticulum; SER, smooth endoplasmic reticulum; ER, endoplasmic reticulum; IDDM, NIDDM, insulin-dependent and non-insulin-dependent diabetes mellitus.

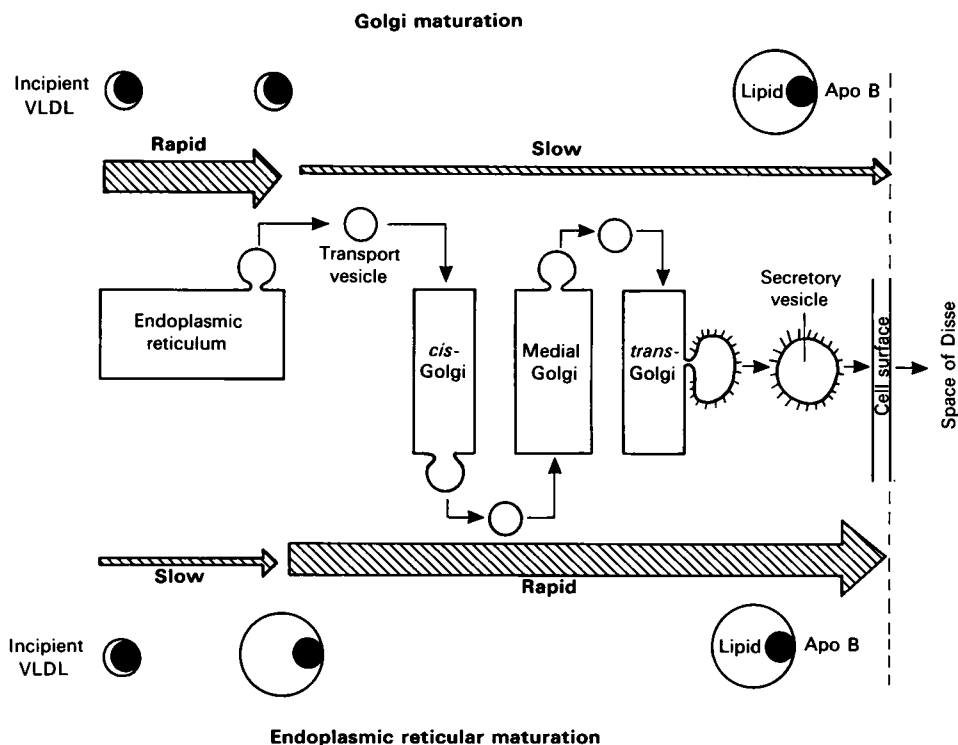

Fig. 1. Kinetics of apo B transport through the secretory apparatus

The transport vesicles which contain the incipient VLDL 'bud-off' from one organelle and fuse with the next in sequence. In the top part of the diagram lipid is added to apo B mainly in the Golgi; in the bottom part, mainly in the ER.

not long enough for transmembrane-spanning [14], the existence of numerous, but shorter, such sequences provide the potential for membrane interaction.

Mammals synthesize two major molecular-mass forms of apo B, the large form of M_r 514000, designated on the centile basis as apo B₁₀₀ [17,18], and a smaller variety designated apo B₄₈. In humans, synthesis of apo B₁₀₀ is restricted exclusively to the liver, and that of apo B₄₈ to the intestine, but the rat is different in that both forms are synthesized and secreted hepatically. The discovery that a single gene coded for both forms of apo B [19] raised the intriguing problem of the molecular mechanism by which this was achieved. Recent work from several laboratories has now shown that apo B in rabbit and human intestine is produced via a unique post-transcriptional modification of the apo B₁₀₀ message [20–24]. This involves a single base change in which the CAA codon normally encoding Gln-2153 in apo B₁₀₀ is substituted for the stop codon UAA. This single C → U substitution results in the formation of apo B₄₈ with a new C-terminal Ile-2152 as the primary translation product. This is cleaved to give Met-2151 as the new C-terminus. A maximum of only 26 nucleotides spanning the modified nucleotide site in the apo B₁₀₀ message appears to be all that is required for recognition by, and binding to, the enzyme responsible for catalysing this single base substitution [25]. This enzyme may be a cytosine deaminase [26]. Previous work had already suggested that the secretions of newly synthesized apo B₁₀₀ and of apo B₄₈ in rat liver are independently controlled by nutritional and developmental signals [27–29]. Since each VLDL particle is thought to contain only one molecule of apo B [30] and, since apo B₄₈ lacks the domain which binds to the apo B₅₀E receptor [22], it might be expected that these particles are metabolized rather slowly. However, hepatic apo B₄₈ is cleared from the plasma more

rapidly than apo B₁₀₀ [30–32], possibly by a receptor which also binds chylomicron remnants.

Post-translational modification of apo B

Glycosylation. There are 20 putative glycosylation sites on apo B [5,13]. Studies using human LDL apo B [33] and nascent VLDL secreted by chick hepatocytes [34] have shown that the oligosaccharide chains are N-linked and are of two types: first, the so-called 'high-mannose' asparagine-linked chains containing a high proportion of mannose units; second, 'complex oligosaccharide' chains. LDL apo B contains 4.4% (by weight) of carbohydrate and the five high-mannose chains comprise a large proportion (37%) of the total monosaccharides of apo B [33]. The glycosylation of apo B occurs in the Golgi fraction [35]. The functional significance (if any) of apo B glycosylation is not known. Tunicamycin, an inhibitor of N-linked glycosylation, does not prevent the secretion of VLDL [34,36]. However, a possible function related to the binding of apo B to the LDL receptor has been proposed [5].

Phosphorylation. In rat hepatocytes, apo B₄₈ is secreted as a phosphoserine-containing protein, but no phosphorylated apo B₁₀₀ could be detected [37,38]. More recently it was shown that both forms of apo B are phosphorylated and secreted by rat hepatocytes [39]. Both serine and tyrosine residues were affected. The reason for this difference is not clear but may relate to the fact that insulin-treated hepatocytes from sucrose-fed rats were used in the former study. Insulin inhibits apo B secretion (see below) and the possibility of hormonal and nutritional control of intracellular apo B metabolism by mechanisms involving protein phosphorylation has not been explored. Indeed, the functional relevance of apo B phosphorylation, if any, is not yet known. If

phosphorylation plays some functional rôle, it is most likely that this is achieved via a conformational change (cf. glycogen phosphorylase [40]) which affects lipid-binding sites.

Fatty acylation. Apo B₁₀₀ secreted by human HEP-G2 cells is acylated with stearic and palmitic acids [41] possibly via a cysteine-linked thioester bond [42]. The intracellular site at which acylation takes place is not known, although the Golgi has been implicated for other acylated proteins such as the major histocompatibility antigens [43]. The functional relevance (if any) of apo B acylation is also obscure, although a role in facilitating interaction between apo B and intracellular membranes has been proposed [41] as has been suggested for other acylated proteins [44]. Other possible functions include the facilitation of lipid binding during VLDL maturation [41] and as a targeting mechanism for intracellular protein sorting. These functions may be achieved by interfering with the tertiary structure of apo B by acylation of some of the free -SH groups of cysteine.

Topography of VLDL assembly

The structural stability of the VLDL particle is largely dependent upon the presence of apo B. Information about how and where the polypeptide becomes associated with lipid in the secretory pathway is, therefore, crucial to an understanding of the exceptionally complex process of VLDL assembly. One of the most striking features to emerge from recent work is the high proportion of apo B which remains bound to the membrane of each compartment of the secretory apparatus, including some elements of the Golgi [15,16,45-47]. This raises the issues of whether, and to what extent, triacylglycerol and other lipids are partly associated with VLDL as a membrane-bound complex, at what point the incipient VLDL particle is released into the secretory lumen, and what factors determine this release. All these issues have obvious implications for the regulation of VLDL assembly and secretion.

Earlier models of VLDL assembly [48-50] have provided a useful framework for understanding the mechanics of VLDL secretion. These models, however, have had to be modified in the light of new findings concerning both apo B structure and synthesis [5,12,13] and the nature and structure of the secretory apparatus (see [9,10,51] for reviews). A central problem is whether or not the site of apo B synthesis is removed from the site(s) at which it becomes associated with the bulk of the lipid. The classic study of Alexander *et al.* [50] provided immunocytochemical evidence that apo B, synthesized in the rough endoplasmic reticulum (RER), encountered triacylglycerol synthesized in the smooth endoplasmic reticulum (SER) only at the junction of the two compartments from where the product, the incipient lipoprotein, was transferred to the Golgi in specialized tubules. Recent morphological evidence suggests that this junctional complex may be a specialized or transition region of the ER from where vesicles 'bud off' for transport to the *cis*-Golgi [9] which is located adjacent to this transition region of the ER (Fig. 1). The validity of the model described by Alexander *et al.* [50] requires, first, that triacylglycerol is synthesized exclusively in the SER and not, partly, in the RER as suggested by others [48,49,52]. Second, it requires that apo B, during its transport through the RER, must retain a conformation suitable for subsequent binding to triacylglycerol. This requirement may help to rationalize many interesting observations concerning the behaviour of apo B in the secretory apparatus and has formed the basis for a comprehensive explanation of VLDL assembly [14]. Very briefly, hydrophobic interactions between the growing chain of newly-translated apo B and the membrane lipids of the ER specify a conformation which is appropriate for binding to triacylglycerol, considerable amounts of which are tightly bound to ER mem-

branes [49]. By analogy with retinol-binding-protein [53], exit of apo B from the ER may be dependent upon its binding to at least a small quantity of triacylglycerol at this site.

The binding of apo B to the membrane of the intracellular transport apparatus may, therefore, reflect the need to maintain a specific conformation until sufficient triacylglycerol has been added to allow this conformation to persist, unsupported, in the aqueous lumen. This implies that membrane-bound apo B acts as a storage pool [45] and may never be completely translocated into the lumen in the absence of factors which ensure the availability of an adequate quantity of secretory triacylglycerol. If the above hypothesis is correct, then those adjacent secretory compartments which show the greatest change in the ratio of membrane-bound:lumenal apo B might be expected to represent the major site of transition of apo B from the predominantly membrane-bound form to the predominantly lipoprotein-associated form. This may also, thus, reflect the major site of lipid transfer and lipoprotein maturation. There is evidence to support two different views as to the location of this site (Fig. 1), although this may vary according to the actual quantity of triacylglycerol available for export. First, several lines of evidence implicate the Golgi and, in particular, during transfer from the medial- to the *trans*-Golgi, as this critical site. For instance, Bamberger & Lane [46], using avian hepatocytes, showed that the ratio of lumenal- to membrane-bound apo B was much greater in a light Golgi fraction (corresponding to the *trans*-Golgi [54]) compared to that in the heavy Golgi (corresponding to the medial- and *cis*-Golgi), or the ER. Second, during its passage through the cell, in both oestrogen-treated chicken hepatocytes and in HEP-G2 cells, apo B spends most of its time in the Golgi [16,46], although this did not appear to be the case in insulin-treated hepatocytes from rat [47,55]. This delay may reflect the extra time required to load triacylglycerol onto the transport vehicle. Finally, the wide heterogeneity of VLDL particle size in the Golgi, only a proportion of which are similar to serum VLDL, also attests to the importance of this site for lipid association with apo B [56]. The major surface lipids of VLDL (phospholipid and non-esterified cholesterol) also appear to be added to the maturing particle in the Golgi apparatus [57,58].

On the other hand, several studies have provided evidence for an important role of the ER during triacylglycerol transfer (Fig. 1). These include experiments using orotic acid, which interrupts the normal assembly of VLDL [59,60]. In the livers of orotic-acid treated rats, for instance, triacylglycerol and apo E, but not apo B, accumulate in 'liposomes' [61] derived, probably, from the transitional or junctional region of the ER and from which proteins are normally transferred to the *cis*-Golgi. The reason for the orotic-acid-induced deficiency of apo B at this site is not known, although it may remain bound to the membrane of the remainder of the ER. Nevertheless, it is apparent from these studies that the absence of a signal normally conferred by apo B prevents the entry of triacylglycerol into the Golgi. The kinetic experiments of Borchardt & Davis [47] also suggest that, in insulin-treated hepatocytes from rat, transport of apo B out of the ER is delayed, implying, perhaps, that this delay is a requirement for addition of lipid. The reason(s) for these reported differences in transit times through a particular part of the secretory apparatus is not clear, but may be related to differences in the availability of triacylglycerol for secretion. It should also be recognized that in addition to species differences, the hepatocytes had been exposed to different hormone treatments.

Whether the transport of VLDL from the *trans*-Golgi to the cell surface is constitutive or regulated is not known for certain, but evidence for the existence of secretory storage vesicles which 'bud off' from the Golgi and which contain VLDL [50] argue for

the latter (Fig. 1). Assuming a regulated transport process for VLDL in secretory storage vesicles, fusion of the latter with the sinusoidal membrane would not occur in the absence of a hormone-mediated signal [51]. Little, if anything, is known about this potentially important aspect of VLDL secretion.

Of the many problems of VLDL assembly which remain to be resolved, three, especially, are relevant to the regulation of VLDL secretion. These are, first, what determines the stage at which apo B is released from the membrane of the secretory apparatus – is it the availability of, or need to secrete, triacylglycerol? Second, if triacylglycerol cannot transfer to the Golgi without apo B [61], how is triacylglycerol added to the incipient VLDL in the Golgi, as suggested by some of the experiments described above? Does this suggest that the Golgi is itself capable of triacylglycerol synthesis? Finally, what are the signals which guide apo B through the complex maze of the secretory apparatus and which target it, specifically, for secretory vesicles rather than to the lysosome or for constitutive secretion?

It is possible that some of these questions may be resolved in terms of the various post-translational modifications of apo B that are known to occur. In this respect, studies directed towards the functional relevance of apo B phosphorylation, glycosylation and acylation may provide some important clues.

NUTRITIONAL AND HORMONAL CONTROL OF HEPATIC VLDL ASSEMBLY AND SECRETION

Effects of nutritional state

Triacylglycerol and apo B synthesis. Studies using liver preparations *in vitro* have shown convincingly that the rate of VLDL triacylglycerol output is dependent upon the nutritional state of the donor animals. In general, conditions which favour a high rate of triacylglycerol synthesis *de novo* from small, carbohydrate-derived precursors are associated with high rates of VLDL output. This occurs with animals fed diets high in sucrose or fructose [27,62–64], in hyperphagic obese Zucker rats compared to their lean littermates [65–67], in fed compared to starved animals [27,28,68–70], in animals fed chow- compared to fat-rich diets [71–73] and in adult compared to suckling animals [29,74]. These relative increases in VLDL output in animals with high rates of hepatic lipogenesis *de novo* also occurred at equivalent concentrations of extracellular non-esterified fatty acids [62,68,70], suggesting that the capacity for VLDL triacylglycerol secretion had increased in these circumstances. In animals such as this, fatty acid synthesized *de novo* contributed a relatively small proportion of the large quantities of VLDL triacylglycerol secreted [67,75], indicating that the increased availability of newly-synthesized fatty acid, in itself, was not the direct cause of the increased VLDL triacylglycerol output but that the two events were somehow co-ordinated in parallel. In this connection, Davis and his colleagues have provided evidence which suggests that an increase in newly-synthesized fatty acids [38] but not of extracellular pre-formed fatty acids [68], is associated with an increase in the secretion of newly-synthesized apo B. Furthermore, fasting, a state characterized by a decrease in the rate of synthesis of fatty acids, resulted in a decreased synthesis and secretion of apo B [28]. However, stimulation *in vitro* of fatty acid synthesis and VLDL triacylglycerol output did not result in a change in the rate of secretion of newly-synthesized apo B [63]. It thus appears that some *in vivo* factor was responsible for the co-ordinate increase in the rates of hepatic fatty acid and apo B synthesis. The nature of this factor remains elusive and, to date, experiments designed to simulate *in vitro* the changes in apo B synthesis obtained after nutritional modification *in vivo* have not been successful.

Partitioning of newly-synthesized triacylglycerol: storage or secretion? There is no doubt that the processes of VLDL assembly and secretion are saturable, that in the presence of high concentrations of extracellular fatty acid, triacylglycerol synthesis exceeds the secretion capacity [76,77] and that under these circumstances triacylglycerol accumulates in the cytosolic storage pool. The capacity for triacylglycerol secretion is higher in normal-fed and sucrose-fed rats than in starved rats [62,70]. Thus changes in the capacity for triacylglycerol secretion as determined by nutritional status may affect the partitioning of newly-synthesized triacylglycerol between the storage pool (cytoplasm) and the secretory pool (VLDL). For instance, the proportion of triacylglycerol entering the secretory pathway is high in chow- and sucrose-fed animals, states characterized by a high rate of fatty acid synthesis *de novo* (see above). In contrast, in diabetes [75,77,78], fat-feeding [73] and in suckling rat liver [29,80], in which the major precursor for hepatic triacylglycerol synthesis is extracellular NEFA, the capacity for VLDL secretion is low and newly-synthesized triacylglycerol accumulates in the cytosol of the cell (Fig. 2).

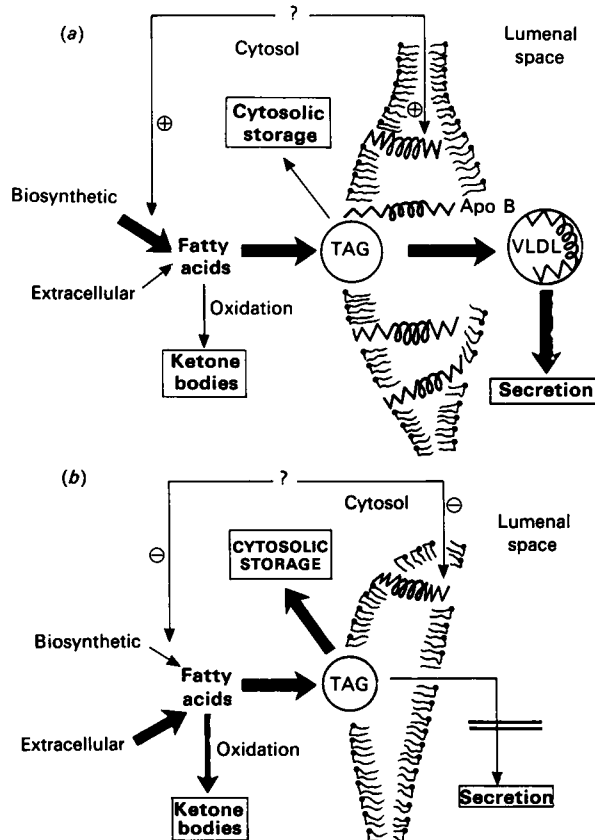

Fig. 2. Channelling of newly-synthesized triacylglycerol into secretory and storage pools

(a) When fatty acid synthesis rates are high, there is an increase in the availability of functional apo B in the leaflets of the ER membrane. VLDL assembly and secretion into the lumenal space is enhanced, whereas triacylglycerol (TAG) transport into the cytosol is relatively suppressed. Under these conditions, fatty acid oxidation is inhibited. (b) A low rate of fatty acid synthesis is associated with a decline in the availability of functional apo B. VLDL assembly is suppressed and there is a relative increase in the amount of triacylglycerol entering the cytosol. Under these conditions, fatty acid oxidation is enhanced. + and - indicate co-ordinate changes in fatty acid synthesis and apo B availability in the ER.

Little is known of the mechanism underlying the regulation of triacylglycerol channelling into the secretory, compared to the hepatic, storage pools. However, it has been suggested that newly synthesized triacylglycerol which arises between the lipid bilayer of the endoplasmic reticulum 'buds off' into the cisternal space of the ER when apo B is present in the membrane but into the cytoplasmic space in the absence of apo B [14]. This implies that the concentration of apo B between the monolayer leaflets of the ER determines the relative proportions of triacylglycerol entering the secretory and storage pools (Fig. 2). It is also possible that a specific triacylglycerol transfer protein [81] may play a role during this process.

Differential metabolism of apo B₁₀₀ and apo B₄₈. In the rat, the secretion of VLDL particles containing apo B₄₈ and those containing apo B₁₀₀ appear to be independently regulated by nutritional and developmental factors which determine the rate of triacylglycerol output by the liver. In general, high rates of hepatic triacylglycerol synthesis *de novo* (from small precursors) are associated with a high rate of hepatic VLDL output and a high apo B₄₈/apo B₁₀₀ ratio and *vice versa* [27–29,67].

It has been suggested that, from a physiological viewpoint, nutritional conditions that favour high rates of VLDL triacylglycerol entry into the plasma must be paralleled by an increased rate of clearance if an excessive hypertriacylglycerolaemia is to be prevented [27,67]. Although this may be achieved peripherally by an insulin-mediated increase in the activity of adipose tissue lipoprotein lipase (LPL), apo B₄₈-containing particles are also hydrolysed by LPL more rapidly than those containing apo B₁₀₀ [30]. There would also be a requirement for an increased rate of removal of the appropriate remnant particle. As particles containing apo B₄₈ are cleared more rapidly than those containing apo B₁₀₀ [30–32], the increased secretion of apo B₄₈ under conditions of increased VLDL output may provide a buffering mechanism preventing an excessively prolonged hypertriacylglycerolaemia. This may explain the low levels of rat plasma LDL, the only source of which is the relatively low amounts of apo B₁₀₀-containing VLDL. By contrast, in suckling rats which secrete a relatively high quantity of apo B₁₀₀ [74], plasma concentrations of LDL are elevated [82].

Hormonal effects

Insulin. In view of the long-established lipogenic role of insulin, until recently it was assumed that the hormone acted directly on the liver to promote the secretion of VLDL. This view was supported by the relationship between hyperinsulinaemia and VLDL production *in vivo* [83–88], and also by reports that insulin, under some conditions, enhanced VLDL triacylglycerol secretion from perfused livers *in vitro* [89,90]. However, this latter observation is not a consistent finding [90,91] and the precise effect of insulin appears to be critically dependent upon the perfusion conditions [90]. Furthermore, insulin administration to human subjects also decreased hepatic VLDL output [92,93], a response which was not due to a decreased rate of uptake of plasma free fatty acids by the liver [92]. In rats, hepatic VLDL secretion rates *in vivo* are higher when plasma insulin levels fall after feeding [94]. Studies with rat hepatocytes (for a review, see [95]) and with human HEP-G2 cells [96,97] have also consistently shown a direct inhibitory effect of insulin during exposure periods shorter than 24 h irrespective of whether or not oleate was present in the culture medium [96,98].

Insulin thus promotes the synthesis of triacylglycerol but, in the short term at least, prevents its secretion from the hepatocyte. Triacylglycerol therefore accumulates intracellularly during this period and is mobilized resulting in an enhanced VLDL secretion if insulin is subsequently removed from the medium [99] (Table

Table 1. Different patterns of insulin exposure influence its effect on VLDL triacylglycerol secretion

Key: +, insulin present; –, insulin absent.

Culture conditions		Relative VLDL triacylglycerol secretion during final 24 h
Previous 48 h	Final 24 h	
+	–	1 (highest)
+	+	2
–	–	3
–	+	4 (lowest)

1). The means by which insulin uncouples the synthesis and secretion of triacylglycerol is not clear. Fatty acids released by hepatic lysosomal lipolysis of cytosolic triacylglycerol [100] appear to contribute to VLDL triacylglycerol [101,102] and inhibition of this lipase by insulin [100] might therefore be expected to suppress the secretion of triacylglycerol. There is also some evidence for an impairment of apo B association with triacylglycerol [103], but the intracellular site(s) accommodating this defect have not been investigated. The synthesis *de novo* of apo B may also be impaired, possibly a secondary effect of defective apo B and lipid association [104]. However, insulin does not affect the expression of the apo B gene in HEP-G2 cells [97]. Pulse–chase experiments have shown that, when insulin is present in the culture medium of rat hepatocytes, a large proportion of newly synthesized apo B is degraded intracellularly rather than secreted [47,105].

In contrast to the inhibitory effect of short-term insulin exposure, when the hormone is present for periods longer than 24–48 h the secretion of VLDL is enhanced [99,106], an effect which may be related to the down-regulation of insulin receptor levels [107]. Recent studies have suggested that the exact response to insulin is dependent upon the extent to which triacylglycerol synthesis is stimulated by the hormone. For instance, if the increased synthesis falls below a threshold level of 120 µg/24 h per mg of protein, then insulin inhibits VLDL secretion; if above this level, secretion is enhanced. This latter level is reached after insulin exposure for periods between 24 and 48 h [99]. The complexity of the insulin effect on VLDL secretion is summarized in Table 1, which shows that rates of VLDL triacylglycerol output during the final 24 h of a 72 h culture period can be manipulated according to the detailed pattern of exposure of the cells to insulin.

Glucagon. Glucagon inhibits the secretion of VLDL triacylglycerol [108–110] and esterified and non-esterified cholesterol [73,108,111] in isolated preparations of rat liver. The effect seems to parallel the rapid inhibitory effect of glucagon on fatty acid synthesis *de novo* [112,113]. Despite this, there is no evidence that chronic exposure to glucagon or cyclic AMP suppresses total cellular triacylglycerol synthesis [114,115]. Indeed, glucagon increases the formation of triacylglycerol from labelled glycerol when hepatocytes are cultured in its presence for 48–72 h [114]. When circulating glucagon concentrations are high *in vivo*, extracellular fatty acids would be an important source of hepatic triacylglycerol and it would thus appear that these are directed preferentially into the hepatic storage pool rather than into the secretory pool. Currently, there is no information on the effect of glucagon on apo B secretion from rat hepatocytes. In HEP-G2 cells in this respect, glucagon is ineffective, although this has been ascribed to a general insensitivity of this cell line to glucagon and cyclic AMP [97]. Whether glucagon plays a physiological role in

regulating hepatic VLDL output is uncertain at present. However, it is notable that hyperglucagonaemia is characteristic of insulin-deficient diabetes, of fat ingestion [116] and during suckling [117,118], all states in which hepatic VLDL secretion decreases. Conversely, the high rate of VLDL secretion by the liver of obese Zucker rats is associated with a decline in plasma glucagon levels [110].

Glucocorticoids and catecholamines. Addition of dexamethasone to the culture medium of hepatocytes results in a stimulation of VLDL triacylglycerol and cholesterol secretion [106,119]. The detailed effects appear to be dependent upon the age of the cells and the presence of lipogenic precursors. Whether or not dexamethasone increases cellular triacylglycerol is controversial [119,120]. The stimulatory effect on VLDL secretion may contribute to the well-established hypertriacylglycerolaemia associated with high circulating levels of adrenal glucocorticoids [115,121]. *In vitro*, glucocorticoids added to the culture medium were unable to reverse the inhibitory effects of insulin on VLDL triacylglycerol [106] and apo B [122] secretion in normal hepatocytes. By contrast, cortisol reversed the inhibitory effect of insulin on apo B secretion in hepatocytes from diabetic rats [122].

Little is known of the direct effects of catecholamines on hepatic VLDL secretion despite the importance of these hormones in regulating lipid metabolism under conditions of acute

stress [123]. Short-term treatment of isolated liver preparations with adrenaline or noradrenaline rapidly suppressed the secretion of VLDL-associated triacylglycerol [124] and cholesterol [111] respectively. This effect may contribute to the decreased plasma triacylglycerol concentration observed in conditions of acute stress [125].

Thyroid hormone. An extensive and sometimes confusing literature exists on the effects of hypo- and hyperthyroidism on hepatic lipid and lipoprotein metabolism (for a review see [126]). Although there appears to be general agreement that, *in vitro*, liver preparations from hyperthyroid animals secrete less VLDL triacylglycerol than normal [126], hepatic VLDL output *in vivo* is unchanged [127] or increased [128,129]. This discrepancy has been ascribed to increased utilization of plasma NEFA in the hyperthyroid state *in vivo* [126]. This may also explain the difference between the high rate of hepatic VLDL secretion *in vitro* in hypothyroidism [126] in contrast to the decreased rates observed *in vivo* [127-129].

Recent studies of the effects of hyper- and hypothyroidism on the expression of the apo B gene in adult animals and during development has also provided some interesting but rather perplexing information. For instance, gene expression decreases during the suckling and weaning periods [130] and, in mice, this decrease is prevented by absolute thyroxine deficiency [131]. However, as hypothyroidism in adult rats leads to a decreased

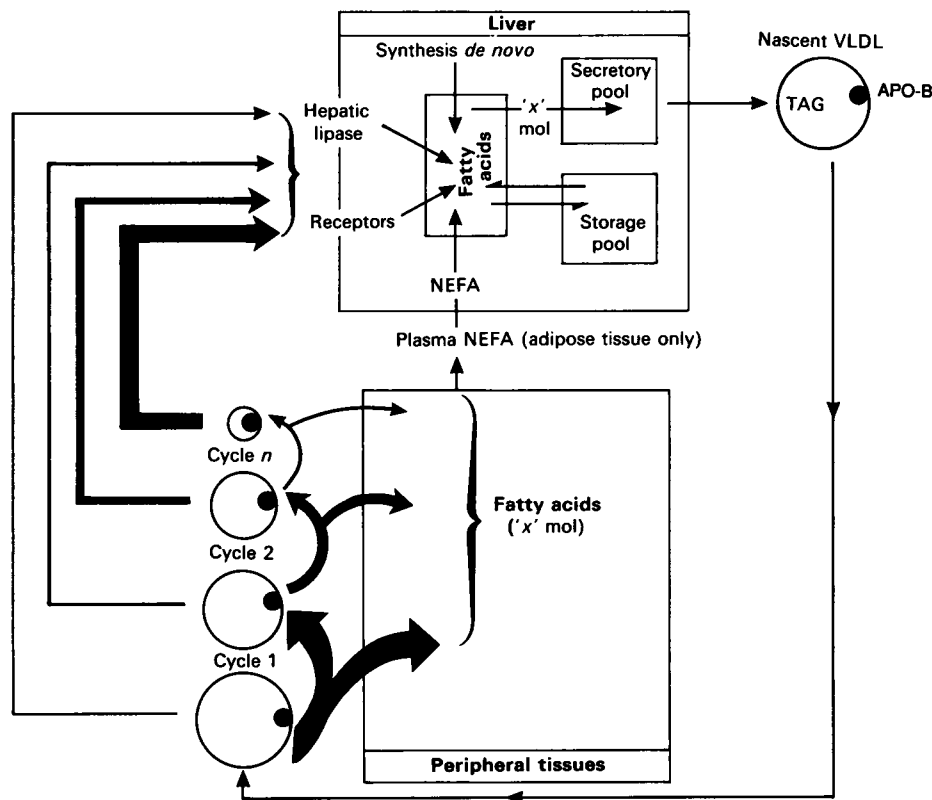

Fig. 3. Source of fatty acid for VLDL triacylglycerol synthesis

VLDL secreted by the liver undergoes sequential lipolysis in a series of cycles through LPL-containing tissues. During this process, 'x' mol of fatty acid are removed. Remaining lipoproteins containing triacylglycerol are returned to the liver at a rate depending upon their size. Fatty acids from this source, together with those derived biosynthetically, from plasma NEFA and from the hepatic cytosol are, potentially, available for the synthesis of VLDL triacylglycerol. The diagram does not take into account the possible compartmentation of the various alternative sources of fatty acid. To maintain a steady state of hepatic triacylglycerol input and output 'x' mol of fatty acid are required to enter the secretory pool from sources other than incoming lipoproteins.

synthesis of apo B₁₀₀ and apo B₄₈ [127], the significance of this finding is not clear. It is interesting that prolonged treatment of rats with thyroxine has recently been shown to promote the insertion of a stop codon into hepatic apo B₁₀₀ mRNA (see above) resulting in the exclusive formation of apo B₄₈ [132]. This may result from an increased activity of a site-specific cytosine deaminase [26].

INTEGRATION OF HEPATIC VLDL SECRETION WITH EXTRA-HEPATIC LIPID METABOLISM

The origin of triacylglycerol for VLDL assembly

There are four potential sources of hepatic VLDL triacylglycerol *in vivo*: fatty acids synthesized *de novo*, plasma non-esterified fatty acids, the stored pool of hepatic triacylglycerol, and triacylglycerol derived from incoming lipoproteins (Fig. 3). Conclusions regarding the relative importance of these sources in different dietary states have been somewhat conflicting, due partly to the variety of models for assessing VLDL triacylglycerol turnover *in vivo* (reviewed in [133,134]), possible species differences, particularly between rat and man [135] and the difficulties in constructing a valid *in vitro* model in which all sources are represented in balanced proportions. Little or no information is available concerning the quantity of newly synthesized fatty acids contributing to VLDL triacylglycerol in man. In the rat, however, studies both *in vivo* and *in vitro* agree that this source makes only a minor contribution even when fatty acid synthesis rates are high [67,75,136]. Thus the elevated VLDL triacylglycerol fatty acid output which often accompanies increases in hepatic fatty acid biosynthesis cannot be accounted for solely by an increase in fatty acids derived from this source. The contribution of newly synthesized fatty acids is even lower in diabetic animals, in animals starved for 24 h and in animals in the pre-prandial state (Table 2). Estimates for the contribution of exogenous

(plasma) NEFA to VLDL triacylglycerol differ according to the model and species used. In livers derived from fed animals and perfused with non-limiting concentrations of NEFA, VLDL triacylglycerol is derived largely from this source [62,67] (see Table 2). However, in the fed state *in vivo*, suppressed peripheral lipolysis limits the amount of plasma NEFA available for hepatic esterification and early studies in the rat [137] suggest that as little as 22% of newly formed hepatic triacylglycerol is derived from this source. Despite the increased availability of plasma NEFA in the starved state, studies in the rat *in vivo* [138] (Table 2) suggest a low contribution from this source and indicates the possible importance of recycled lipoprotein triacylglycerol returning from peripheral tissues [160]. In the dog [139] and in man [140], however, plasma NEFA appear to make a major contribution in the starved state.

Nevertheless, species differences apart, the balance of evidence suggests that there are occasions in which the sum of newly synthesized and plasma fatty acids is insufficient to account for the overall rate of VLDL triacylglycerol output into the plasma. In the rat, this shortfall cannot be accommodated indefinitely by the relatively small quantity of intrahepatic triacylglycerol (4–8 mg/g fresh wt.). The only remaining source of triacylglycerol *in vivo* is that derived from lipoproteins returning to the liver from peripheral organs. This quantity is dependent upon the affinity of liver receptors and hepatic lipase for triacylglycerol-containing lipoproteins. These affinities bear an inverse relationship to the size of the particle [141], in contrast to the activity of peripheral tissue lipoprotein lipase which is positively correlated with particle size (Fig. 3). In starved rats, recycled triacylglycerol has been shown to contribute 83% of the newly secreted hepatic triacylglycerol [160]. Uptake by the liver was also the major fate of labelled VLDL triacylglycerol administered to starved rabbits [142] and in starved rats only 30% (4.4 μ mol/min per kg body wt.) of the secreted VLDL triacylglycerol fatty acid

Table 2. Contribution of various sources of fatty acids of VLDL triacylglycerol

Species	Nutritional state	Experimental model	Contribution (%) of fatty acids from stated source	Reference
Rat	48 h fasted	<i>In vivo</i>	83% recycled, 17% NEFA	[138]
Rat	Fed, mid-lactating	<i>In vivo</i>	9.6% newly synthesized*	[136]
Rat	Fed, 24 h weaned	<i>In vivo</i>	19.4% newly synthesized*	[136]
Rat	Glucose-fed	<i>In vivo</i>	22% NEFA†	[137]
Rat	Fed	Perfused liver	90% NEFA	[67]
Rat	Fructose-fed	Perfused liver	64–100% NEFA‡	[62]
Rat	Fed	Perfused liver	9% newly synthesized	[67]
Rat	Fed, mid-dark	<i>In vivo</i>	7.7% newly synthesized	[75]
Rat	Fed, mid-light	<i>In vivo</i>	2.4% newly synthesized	[75]
Rat	24 h-starved	<i>In vivo</i>	0.6% newly synthesized	[75]
Dog	Starved	<i>In vivo</i>	100% NEFA	[139]
Man	Starved	<i>In vivo</i>	100% NEFA	[140]
Rat	Fed	Perfused liver	30% newly synthesized	[89]

* VLDL not separated from chylomicrons.

† NEFA as % of newly-formed liver triacylglycerol; VLDL not measured.

‡ Exact contribution depended upon extracellular fatty acid concentrations.

(14.4 $\mu\text{mol}/\text{min}$ per kg body wt.) was oxidized peripherally [1]. As adipose tissue uptake was minimal, the remainder was probably returned to the liver. Furthermore, several studies have shown that, *in vitro*, although the liver can acquire triacylglycerol by the rapid uptake of VLDL remnants [143], particles richer in triacylglycerol are also removed [69,144].

The role of insulin

Dietary energy, consumed in excess of an animal's immediate requirements, is temporarily stored during periods of high food intake and made readily available for energy-requiring tissues when food intake is low. The role of insulin in this process may explain its uncoupling of triacylglycerol synthesis from secretion, the physiological purpose of which probably stems from the energy requirements of muscle tissue. Evidence obtained in rats suggests that when food intake is low, direct oxidation of VLDL triacylglycerol fatty acids is at least as important a source of energy for muscle tissue as is the oxidation of plasma NEFA [1]. This finding implicates LPL activity as a critical factor in the supply of lipid energy to these tissues. This is supported by the diurnal pattern of muscle LPL activity which peaks during periods of low food intake when plasma insulin levels are low [145]. It is possible, therefore, that insulin promotes the synthesis and temporary storage of hepatic triacylglycerol during periods of food intake, and this is then mobilized to meet the increased demands of muscle tissue for lipid-derived energy when food intake and plasma insulin levels are low. In support of this, experiments *in vivo* have shown that the liver secretes somewhat more VLDL triacylglycerol during that part of the diurnal cycle when food intake is low [94]. Furthermore, in hepatocyte cultures, triacylglycerol stored within the cell during exposure to insulin is released into the medium as VLDL when insulin is removed [99]. If this hypothesis is correct, then insulin co-ordinates the temporary storage of hepatic triacylglycerol with that of adipose tissue triacylglycerol and hepatic and muscle glycogen as part of the overall process by which the body ensures the efficient long-term utilization of dietary energy intake.

Response to dietary fat

An important question is whether the consumption of dietary fat affects the secretion of hepatic VLDL and, if so, what are the mechanisms involved. Theoretically, it might be expected that in a situation where the body's requirement for triacylglycerol can be met wholly from the intestinal source, the requirement for hepatic VLDL should be reduced or abolished. There is little doubt that dietary supplementation with fat decreases the rate of hepatic fatty acid synthesis *de novo* [146,147] and it has already been noted that, in many situations, fatty acid synthesis is positively linked with VLDL triacylglycerol output (see above). Although there are differences in detail, the balance of direct evidence also suggests that, in rats, supplementation of the normal high-carbohydrate diet with fat suppresses the secretion of hepatic VLDL. The extent of suppression is dependent upon the nature of the fat consumed. For instance, in this species, saturated animal fat [71,148], polyunsaturated vegetable oil [73] and *n*-3 polyunsaturated fish oils [72,149,150] reduced VLDL secretion rates. Fish-oil appears to be more potently active than other types of dietary fat in suppressing hepatic VLDL secretion [72,151] and this may be a major contributory factor underlying the hypolipidaemic effect of diets rich in *n*-3 fatty acids. Enhanced clearance of VLDL due to a stimulation of LPL activity is not observed [152]. On the other hand, the hypotriacylglycerolaemic effect of safflower-oil compared to corn-oil appeared to be due principally to an increase in LPL activity [153]. No differences in VLDL secretion rate were observed when the two diets were compared. VLDL secretion rates in animals

fed a diet lacking in fat were not studied in this report. Finally, in non-human primates, a diet rich in peanut oil decreased VLDL triacylglycerol and apo B secretion in hepatic perfusates *in vitro*. Feeding lard decreased these parameters in Rhesus monkeys but not in baboons [154].

What is the mechanism by which dietary fats, and particularly *n*-3 polyunsaturated fat, suppress hepatic VLDL secretion? It has been noted previously (see above) that in rats changes in the fatty acid synthesis rate are positively associated with changes in the rate of secretion of VLDL triacylglycerol and apo B, particularly apo B₄₈. The molecular mechanism underlying this relationship is not known. In this respect, it has been clear for some time that the consumption of dietary fat suppresses hepatic fatty acid synthesis to an extent depending upon the structure of the dietary fatty acids [146]. This is generally attributed to an increase in the concentration of plasma NEFA [155] resulting in a decreased activity of acetyl-CoA carboxylase [150]. Differential changes in the fluidity of membranes of cellular compartments [155] may also contribute to the varying metabolic effects of different dietary triacylglycerol fatty acids. High plasma NEFA levels do not always, however, suppress hepatic fatty acid synthesis, nor VLDL secretion rates, as evidenced by the elevation of both these parameters in the obese Zucker rat [62,67]. In this case, hypoglucagonaemia may be an important contributory factor to the increased output of hepatic VLDL [110].

Some comments on the measurement of hepatic VLDL secretion rates *in vivo* and *in vitro*

In vivo, two techniques have been widely used for determining VLDL triacylglycerol secretion rates. First, information has been derived from calculations based upon isotopic measurements of VLDL triacylglycerol turnover. This method has been applied to man and to smaller experimental animals (for a critical review of this methodology, see [134]). Second, in smaller animals, VLDL secretion into the plasma has been measured using Triton WR-1339 to block peripheral lipolysis. In the rat, the first method has generally resulted in rates which are higher than those obtained using Triton (see Table 3), a difference which may be due to incomplete inhibition of peripheral lipolysis by Triton [156]. Furthermore, detergents such as Triton may expose the normally-inaccessible receptor binding domain of apo B₁₀₀ on VLDL [55]. Thus some nascent VLDL may be cleared by the liver apo B,E receptor in the presence of Triton. This method, therefore, may under-estimate the true rate of hepatic VLDL triacylglycerol secretion into the plasma *in vivo*. Despite the possibility of VLDL leakage, results obtained using this method generally exceed those observed *in vitro* using perfused livers, even when non-limiting concentrations of non-esterified fatty acids are added to the perfusate (Table 4). Rates of VLDL triacylglycerol output in hepatocytes during the first 24 h in culture are very similar to those obtained in perfused liver and again fail to match the higher rates measured *in vivo* (Table 4). The reason for this shortfall *in vitro* is not clear, but it is notable that when blood and/or plasma was included in the perfusate, hepatic triacylglycerol secretion rates were higher [157,158]. Hepatocytes in culture may, under some conditions, be induced to secrete VLDL triacylglycerol at a rate (188 μg of triacylglycerol/24 h per mg of protein, which corresponds to 0.31 μmol of triacylglycerol fatty acids/min per 100 g) approaching the average of the *in vivo* (Triton) rates, but this was only achieved at a concentration of cellular triacylglycerol which was 10-fold higher than normal [99]. It is also not readily apparent why starvation shows no effect on the rate of appearance of plasma VLDL *in vivo* (Table 3) [159] whereas *in vitro* VLDL secretion decreases both in isolated perfused livers [27,69,70] and in isolated hepatocytes [28,68] derived from starved animals. The effects of hyperthyroidism on VLDL output *in vivo*

Table 3. VLDL triacylglycerol fatty acid output *in vivo*

Method	State of rats	VLDL triacylglycerol fatty acid output ($\mu\text{mol}/\text{min}$ per 100 g)*		Reference
		Mean \pm S.E.M.	Range	
Triton	Fed	0.69 \pm 0.12	0.36–1.29 ($n = 6$)	[75,94,162,166–168]
Triton	Fasted	0.62 \pm 0.03	0.53–0.71 ($n = 5$)	[75,162–165]
Isotopic (VLDL turnover)	Fed + fasted†	1.30 \pm 0.11	1.01–1.50 ($n = 4$)	[1,137,138,166]

* The unit of VLDL output differs between the various reports. The above values have been standardized to a common unit assuming a plasma volume of 4.1% of body wt. [162] and a liver-to-body-wt. ratio of 0.04 [75].

† There were no differences in the values for fed and fasted animals. These have been combined.

Table 4. VLDL triacylglycerol fatty acid secretion rates in isolated liver preparations *in vitro*

	NEFA present	VLDL triacylglycerol fatty acid output* ($\mu\text{mol}/\text{min}$ per 100 g)	Range	Reference
Perfused liver	+†	0.18 \pm 0.04	0.07–0.42	[67,64,65,69,157,160,161]
	–	0.12 \pm 0.05	0.04–0.31	[29,70,157,169,170]
Hepatocytes	+‡	0.19	–	[98]
	–	0.12 \pm 0.01	0.10–0.16	[106,103,171,172]

* Values for perfused liver have been calculated using liver-to-body-wt. ratio of 0.04 [75]. Values for hepatocytes are normally reported as $\mu\text{mol}/\text{mg}$ of protein. These have been converted to the above values assuming a liver protein content of 160 mg/g and a liver-to-body-wt. ratio of 0.04. All measurements in hepatocytes were carried out during the first 24 h after plating the cells.

† NEFA concentrations ranged between 0.3 and 1.09 mM.

‡ NEFA concentration 0.75 mM.

[127] and *in vitro* [126] are also inconsistent, as are the effects of insulin-deficient diabetes [75,78,98,160,161]. In both these states the rates measured *in vivo* using Triton WR-1339 did not change, whereas *in vitro* there were decreases in hepatic VLDL output rates. In interpreting these results, it should be borne in mind that the Triton method measures total VLDL input into the plasma and does not discriminate between a hepatic and a possible intestinal source.

DEFECTS IN VLDL ASSEMBLY AND SECRETION

Diabetes

Abnormalities of lipoprotein metabolism are common features of both the insulin-dependent (IDDM) and non-insulin-dependent (NIDDM) forms of diabetes (for reviews, see [85–88]). These diabetic states differ from each other in their metabolic effects, including the hepatic secretion of VLDL.

Non-insulin-dependent diabetes (NIDDM). There is wide agreement that in NIDDM, a state characterized by tissue resistance to insulin, the production of hepatic VLDL triacylglycerol is increased (see [86] for a review). The magnitude of the increase in apo B production, however, is not so large, resulting in a particle of abnormal size and composition [173]. The cause(s) of the increased VLDL triacylglycerol output in NIDDM has not been positively identified. Several metabolic abnormalities associated with this state, including hyperglycaemia, elevated concentrations of plasma NEFA, and hypoglucagonaemia, when simulated *in vitro*, have each been shown to produce an increase in hepatic VLDL triacylglycerol secretion (for a review see [95]).

The direct effect of insulin itself on VLDL secretion in NIDDM also remains to be resolved. It has been argued that hyperinsulinaemia, which is commonly associated with this diabetic state, acts positively on the liver to stimulate the secretion of VLDL (for a review, see [88]). This hypothesis, however, fails to account for the inhibitory effect of insulin on hepatic VLDL secretion observed in many studies both *in vitro* and *in vivo* (see above). An alternative explanation has been proposed which involves loss of sensitivity to the normal, insulin-induced suppression of hepatic VLDL secretion [85].

Insulin-dependent diabetes (IDDM). Experimental insulin deficiency in rats is associated with a decreased output of VLDL triacylglycerol in isolated liver preparations. This occurs both in short-term studies in the perfused liver model [78,160,161] and, over the longer term, in hepatocyte cultures [98]. This is accompanied by a decline in the secretion of apo B [39,122,174]. Since direct comparisons have not yet been made, it is not known whether VLDL triacylglycerol and apo B outputs decrease to the same extent. However, *in vitro* the secretion of non-esterified cholesterol is not affected to the same extent as triacylglycerol and this altered ratio, if reflected *in vivo*, may affect the further metabolism of the particle [98]. The abnormalities of VLDL triacylglycerol and apo B secretion cannot be rectified by addition of insulin to the medium; in fact, a further decline is observed under these conditions [98,122].

The decrease in hepatic VLDL secretion *in vitro* is in sharp contrast to the unchanged or increased rates of VLDL triacylglycerol input into the plasma measured after Triton WR-1339 administration to rats with a similar severity of diabetes [75,165],

and in human subjects with IDDM [84,175–177]. An increase in intestinal VLDL secretion occurs in insulin-deficient rats [165], although the extent of this change was not sufficient to compensate for the large decrease in hepatic production. Nevertheless, the apoprotein content of the plasma VLDL [178] and the increased intestinal synthesis of cholesterol [179] and triacylglycerol [180] in diabetic animals may reflect the increased importance of this organ in contributing to the plasma VLDL input in insulin-deficient diabetes.

The rapid effect of insulin deficiency *in vivo* in reducing VLDL secretion from subsequently derived perfused liver [78] contrasts with the direct stimulatory effect observed when insulin is removed from hepatocyte cultures (see above). Further, in contrast to its effects on diabetic hepatocytes *in vitro* [98], insulin administration to diabetic animals *in vivo* restored to normal the secretion of VLDL triacylglycerol [78] and apo B [122] in isolated liver preparations derived from them. These observations suggest that the suppressive effect of insulin-deficiency *in vivo* is indirect and is mediated by some other factor.

Obesity

Obese subjects are often diabetic and in many cases it is difficult to assess the contribution of each state to the observed abnormalities of lipoprotein metabolism. Nevertheless, it is clear that obesity itself, in the absence of diabetes, is associated with defects in the metabolism of lipids and lipoproteins. As regards VLDL, the obese state is accompanied by an increased rate of output of triacylglycerol [173,181,182] and apo B [173,181,183]. Both apo B and triacylglycerol increased to the same extent, producing increased numbers of VLDL particles with unchanged size or composition [173]. In some cases, this leads to hypertriacylglycerolaemia but in others, VLDL levels are not elevated owing to a compensatory increase in the clearance of VLDL [181], possibly resulting from elevated adipose tissue LPL activity [184]. There appear to be at least two reasons for the increased VLDL secretion rates in obesity. In man, increased availability and utilization of NEFA for VLDL triacylglycerol synthesis has been implicated [181]. Altered partitioning of NEFA [66] also contributes to the increased hepatic VLDL triacylglycerol secretion in the obese Zucker rat, widely used as a metabolic model for human obesity [169,185]. In this model, increased fatty acid synthesis *de novo* also appears to be a major contributory factor [67]. More recently, in human subjects, insulin resistance, which is common in obesity, has been linked to increased plasma VLDL concentration, probably via an increase in hepatic VLDL secretion [186].

Alcohol consumption

The effects of alcohol consumption on VLDL metabolism are controversial and appear to differ according to the quantities involved and the periods during which alcohol is consumed. For instance, in normal subjects, moderate alcohol intake (2636 kJ/day for 4 weeks) had no effect on VLDL triacylglycerol production rates [187]. However, in alcoholic men, VLDL triacylglycerol production increased compared to non-alcoholic control subjects even though there was no change in apo B production [188]. This appears to be in accord with earlier reports in rats [189] and baboons [190] that chronic ethanol consumption led to an increased output of VLDL triacylglycerol. However, a more recent study has shown that VLDL triacylglycerol secretion into the plasma is decreased in rats consuming 14 g of ethanol/kg body wt. per day for 4 weeks [191]. It has been proposed that this is a major cause of alcoholic fatty liver and is due, at least in part, to a defect in the movement of VLDL out of the Golgi [192]. It is possible that the reported differences

using the rat model may reflect differences in ethanol consumption (3 g/kg in [189]; 14 g/kg in [191]).

Studies *in vitro* using hepatocyte cultures have shown that ethanol at a concentration of 50 mM (equivalent to a blood concentration *in vivo* of 230 mg/dl) affects triacylglycerol metabolism and results in an accumulation of cellular triacylglycerol [120]. This is accompanied by a decrease in the rate of secretion of VLDL triacylglycerol into the medium [193].

SUMMARY AND CONCLUSIONS

In contrast to water-soluble fuels such as glucose or ketone bodies, the use of lipids as an energy source for tissues has required the development of complex structures for their transport through the aqueous plasma. In the case of endogenously synthesized triacylglycerol this is achieved by the assembly and secretion of hepatic VLDL which provides the necessary stability in an aqueous medium. An essential component of this assembly process is apo B. Dietary changes which require an increase in hepatic VLDL secretion appear to be accompanied by increases in the availability of functional apo B. Interesting questions relate to: (a) the intracellular site(s) of triacylglycerol association with apo B, and (b) the mechanism(s) by which the availability of functional apo B at this site responds to metabolic and hormonal signals which reflect dietary status and, thus, the need to secrete triacylglycerol. As regards the latter, although in some cases changes in apo B synthesis occur in response to VLDL secretion hepatic apo B mRNA levels appear to be quite stable *in vitro* [97]. Intracellular switching of apo B between the secretory and degradative pathways may be important in controlling VLDL assembly and post-translational modifications of the apoprotein may also play a role by influencing its ability to bind to triacylglycerol.

Transport is not the only problem associated with the utilization of a concentrated energy source such as triacylglycerol and the complex problems of waste product disposal and recycling have to be dealt with. In the case of triacylglycerol, potentially toxic waste products include atherogenic remnants and LDL. The overall problem, then, in the long-term, involves the development of a 'safe' means of utilizing triacylglycerol and this requirement accounts for much of the complexity of plasma lipoprotein metabolism. In this area, the rat could teach the human a few tricks. One of these appears to be the utilization of hepatic apo B₄₈ rather than apo B₁₀₀ for VLDL assembly in response to increases in the extrahepatic utilization of hepatically synthesized triacylglycerol. Under these conditions, the remnants of hepatic triacylglycerol utilization by peripheral tissues are cleared from the plasma much more readily via a process which seems to involve the cycling of more triacylglycerol back to the liver than that which occurs in humans. The means by which this is achieved, though, are obscure and may involve a chylomicron remnant receptor, the nature of which, itself, remains controversial [194]. The key to the problem of 'safe' transport, then, may be linked at least in part to the regulation of hepatic apo B₄₈ production, a process already known to be under post-transcriptional control [25].

I would like to thank my present colleagues in the Metabolic Research Laboratory and my former colleagues in the M.R.C. Lipid Metabolism Unit for many stimulating discussions of lipoprotein metabolism. Thanks are also due to Mrs. M. Barber for typing this manuscript, and to the staff of the Medical Illustrations Department, John Radcliffe Hospital, Oxford, for preparing the diagrams. I am a member of the Medical Research Council External Scientific Staff at the University of Oxford.

REFERENCES

1. Wolfe, R. R. & Durkot, M. J. (1985) *J. Lipid Res.* **26**, 210–217
2. Isselbacher, K. J., Scheig, R., Plotkin, G. R. & Caulfield, J. B. (1964) *Medicine* **43**, 347–359
3. Herbert, P. M., Assmann, G., Gotto, A. M., Jr. & Fredrickson, D. S. (1983) in *The Metabolic Basis of Inherited Disease*, 5th edn. (Stanbury, J. B., Wyngaarden, J. B., Fredrickson, D. S., Goldstein, J. L. & Brown, M., eds.), pp. 589–651, McGraw-Hill, New York
4. Gibbons, G. F., Mitropoulos, K. A. & Myant, N. B. (1982) in *Biochemistry of Cholesterol*, pp. 235–254, Elsevier Biomedical Press, Amsterdam
5. Yang, C.-Y., Chen, S.-H., Gianturco, S. H., Bradley, W. A., Sparrow, J. T., Tanimuro, W. A., Li, W.-H., Sparrow, D. A., Detoof, H., Rossenen, M., Lee, F.-S., Gu, Z.-W., Gotto, A. M., Jr. & Chan, L. (1986) *Nature (London)* **323**, 738–742
6. Palade, G. (1975) *Science* **189**, 347–358
7. Dunphy, W. G. & Rothman, J. E. (1985) *Cell* **42**, 13–21
8. Farquhar, M. G. (1985) *Annu. Rev. Cell Biol.* **1**, 447–488
9. Pfeffer, S. R. & Rothman, J. E. (1987) *Annu. Rev. Biochem.* **56**, 829–852
10. Lingappa, V. R. (1989) *J. Clin. Invest.* **83**, 739–751
11. Lodish, H. E., Kong, N., Snider, M. & Strous, G. J. A. M. (1983) *Nature (London)* **304**, 80–83
12. Chen, S.-H., Yang, C.-Y., Chen, P.-F., Setzer, D., Tanimura, M., Li, M.-H., Gotto, A. M. & Chan, L. (1986) *J. Biol. Chem.* **261**, 12918–12921
13. Knott, T. J., Pease, R. J., Powell, L. M., Wallis, S. C., Rall, S. C., Jr., Innerarity, T. L., Blackhart, B., Taylor, W. H., Marcel, Y., Milne, R., Johnson, D., Fuller, M., Lusic, A. J., McCarthy, B. J., Mahley, R. W., Levy-Wilson, B. & Scott, J. (1986) *Nature (London)* **323**, 734–738
14. Olofsson, S.-O., Bjursell, G., Boström, K., Carlsson, P., Elovson, J., Protter, A. A., Reuben, M. A. & Bondjers, G. (1987) *Atherosclerosis* **68**, 1–17
15. Boström, K., Wettesten, M., Borén, J., Bondjers, G., Wiklund, O. & Olofsson, S.-O. (1986) *J. Biol. Chem.* **261**, 13800–13806
16. Boström, K., Borén, J., Wettesten, M., Sjöberg, A., Bondjers, G., Wiklund, O., Carlsson, P. & Olofsson, S.-O. (1988) *J. Biol. Chem.* **263**, 4434–4442
17. Kane, J. P. (1983) *Annu. Rev. Physiol.* **45**, 637–650
18. Hardman, D. & Kane, J. P. (1986) *Methods Enzymol.* **128A**, 262–272
19. Young, S. G., Bertics, S. J., Scott, T. M., Dubois, B. W., Curtiss, L. K. & Witztum, J. L. (1986) *J. Biol. Chem.* **261**, 2995–2998
20. Hospattankar, A. V., Higuchi, K., Law, S. W., Meglin, N. & Brewer, H. B. (1987) *Biochem. Biophys. Res. Commun.* **148**, 279–285
21. Powell, L. M., Wallis, S. C., Pease, R. J., Edwards, Y. H., Knott, T. J. & Scott, J. (1987) *Cell* **50**, 831–840
22. Chen, S.-H., Habib, G., Yang, C.-Y., Gu, Z.-W., Lee, B. R., Weng, S.-A., Silberman, S.-R., Cai, S.-J., Deslypere, J. P., Rossenen, M., Gotto, A. M., Li, W.-H. & Chan, L. (1987) *Science* **238**, 363–366
23. Brewer, H. B., Higuchi, K., Hospattankar, A., Hoeg, J. & Gregg, R. E. (1988) in *Hyperlipidaemia and Atherosclerosis* (Suckling, K. E. & Groot, P. H. E., eds.), pp. 33–46, Academic Press, London
24. Scott, J., Wallis, S. C., Pease, R. J., Knott, T. J. & Powell, L. (1988) in *Hyperlipidaemia and Atherosclerosis* (Suckling, K. E. & Groot, P. H. E., eds.), pp. 47–64, Academic Press, London
25. Davies, M. S., Wallis, S. C., Driscoll, D. M., Wynne, J. K., Williams, G. W., Powell, L. M. & Scott, J. (1989) *J. Biol. Chem.* **264**, 13395–13398
26. Boström, K., Lauer, S., Poksay, K. S., Garcia, Z., Taylor, J. M. & Innerarity, T. L. (1989) *J. Biol. Chem.* **264**, 15701–15708
27. Windmueller, H. G. & Spaeth, A. E. (1985) *J. Lipid Res.* **26**, 70–81
28. Davis, R. A., Boogaerts, J. R., Borchardt, R. A., Malone-McNeil, M. & Archambault-Schexnayder, J. (1985) *J. Biol. Chem.* **260**, 14137–14144
29. Coleman, R. A., Haynes, E. B., Sand, T. M. & Davis, R. A. (1988) *J. Lipid Res.* **29**, 33–42
30. Elovson, J., Huang, O., Baker, N. & Kannan, R. (1981) *Proc. Natl. Acad. Sci. U.S.A.* **78**, 157–161
31. Wu, A.-L. & Windmueller, H. G. (1981) *J. Biol. Chem.* **256**, 3615–3618
32. Sparks, C. E. & Marsh, J. B. (1981) *J. Lipid Res.* **22**, 519–527
33. Vauhkonen, M., Viitala, J., Parkkinen, J. & Rauvala, H. (1985) *Eur. J. Biochem.* **152**, 43–50
34. Suita-Mangano, P., Janero, D. R. & Lane, M. D. (1982) *J. Biol. Chem.* **257**, 11463–11467
35. Dolphin, P. J. & Rubinstein, D. (1976) *Can. J. Biochem.* **55**, 83–90
36. Struck, D. K., Suita, P. B., Lane, M. D. & Lennarz, W. J. (1978) *J. Biol. Chem.* **253**, 5332–5337
37. Davis, R. A. & Borchardt, R. A. (1986) *Methods Enzymol.* **129B**, 536–542
38. Davis, R. A., Clinton, G. M., Borchardt, R. A., Malone-McNeil, M., Tan, T. & Lattier, G. R. (1984) *J. Biol. Chem.* **259**, 3383–3386
39. Sparks, J. D., Sparks, C. E., Roncone, A. M. & Amatruda, J. M. (1988) *J. Biol. Chem.* **263**, 5001–5004
40. Sprang, S. R., Acharya, K. R., Goldsmith, E. J., Stuart, D. I., Varvill, K., Fletterick, R. J., Madsen, N. B. & Johnson, L. N. (1988) *Nature (London)* **336**, 215–221
41. Hoeg, J. M., Meng, M. S., Ronan, R., Demoski, S. J., Jr., Fairwell, T. & Brewer, H. B., Jr. (1988) *J. Lipid Res.* **29**, 1215–1220
42. Huang, G., Lee, D. M. & Singh, S. (1988) *Biochemistry* **27**, 1395–1400
43. Kaufman, J. F., Krangel, M. S. & Strominger, J. L. (1984) *J. Biol. Chem.* **259**, 7230–7238
44. Magee, A. J. & Schlesinger, M. J. (1982) *Biochim. Biophys. Acta* **694**, 279–289
45. Wong, L. & Pino, R. M. (1987) *Eur. J. Biochem.* **164**, 357–367
46. Bamberger, M. J. & Lane, M. D. (1988) *J. Biol. Chem.* **263**, 11868–11878
47. Borchardt, R. A. & Davis, R. A. (1987) *J. Biol. Chem.* **262**, 16394–16402
48. Stein, O. & Stein, Y. (1967) *J. Cell Biol.* **33**, 319–339
49. Glaumann, H., Bergstrand, A. & Ericsson, J. L. E. (1975) *J. Cell Biol.* **64**, 356–377
50. Alexander, C. A., Hamilton, R. L. & Havel, R. J. (1976) *J. Cell Biol.* **69**, 241–263
51. Kelly, R. B. (1985) *Science* **230**, 25–32
52. Van Golde, L. M. G., Fleischer, B. & Fleischer, S. (1971) *Biochim. Biophys. Acta* **249**, 318–330
53. Ronne, H., Ocklind, C., Wiman, K., Rask, L., Obrink, B. & Petersen, P. A. (1983) *J. Cell Biol.* **96**, 907–910
54. Ehrenreich, J. H., Bergeron, J. J. M., Siekevitz, P. & Palade, G. E. (1973) *J. Cell Biol.* **59**, 45–72
55. Davis, R. A., Prewett, A. B., Chan, D. C. F., Thompson, J. J., Borchardt, R. A. & Gallaher, W. R. (1989) *J. Lipid Res.* **30**, 1185–1196
56. Howell, K. E. & Palade, G. E. (1982) *J. Cell Biol.* **92**, 833–845
57. Higgins, J. A. & Hutson, J. L. (1984) *J. Lipid Res.* **25**, 1295–1305
58. Higgins, J. A. & Fieldsend, J. K. (1987) *J. Lipid Res.* **28**, 268–278
59. Pottenger, L. A. & Getz, G. S. (1971) *J. Lipid Res.* **12**, 450–459
60. Novikoff, P. M., Roheim, P. S., Novikoff, A. B. & Adelstein, D. (1974) *Lab. Invest.* **30**, 732–750
61. Hay, R., Fleming, R., O'Connell, W., Kirschner, J. & Oppliger, W. (1988) *J. Lipid Res.* **29**, 981–995
62. Schonfeld, G. & Pfeleger, B. (1971) *J. Lipid Res.* **12**, 614–621
63. Boogaerts, J. R., Malone-McNeil, M., Archambault-Schexnayder, J. & Davis, R. A. (1984) *Am. J. Physiol.* **246**, E77–E83
64. Yamamoto, M., Yamamoto, I., Tanaka, Y. & Ontko, J. A. (1987) *J. Lipid Res.* **28**, 1156–1165
65. Schonfeld, G. & Pfeleger, B. (1971) *Am. J. Physiol.* **220**, 1178–1181
66. Fukuda, N., Azain, M. J. & Ontko, J. A. (1982) *J. Biol. Chem.* **257**, 14066–14072
67. Azain, M. J., Fukuda, N., Chao, F.-F., Yamamoto, M. & Ontko, J. A. (1985) *J. Biol. Chem.* **260**, 174–181
68. Davis, R. A. & Boogaerts, J. R. (1982) *J. Biol. Chem.* **257**, 10908–10913
69. Wilcox, H. G. & Heimberg, M. (1987) *J. Lipid Res.* **28**, 351–360
70. Salam, W. H., Wilcox, H. G. & Heimberg, M. (1988) *Biochem. J.* **251**, 809–816
71. Kalopissis, A.-D., Griglio, S., Malewiak, M.-I., Rozen, R. & LeLievre, X. (1981) *Biochem. J.* **198**, 373–377
72. Wong, S. H., Nestel, P. J., Trimble, R. P., Storer, G. B., Illman, R. J. & Topping, D. L. (1984) *Biochim. Biophys. Acta* **792**, 103–109
73. Gibbons, G. F. & Pullinger, C. R. (1987) *Biochem. J.* **243**, 487–492
74. Imaizumi, K., Lu, Y.-F. & Sugano, M. (1985) *Biochim. Biophys. Acta* **837**, 345–348
75. Duerden, J. M. & Gibbons, G. F. (1988) *Biochem. J.* **255**, 929–935
76. Chao, F.-F., Stiers, D. L. & Ontko, J. A. (1986) *J. Lipid Res.* **27**, 1174–1181
77. Woodside, W. F. & Heimberg, M. (1978) *Metab. Clin. Exp.* **27**, 1763–1777
78. Woodside, W. F. & Heimberg, M. (1976) *J. Biol. Chem.* **251**, 13–23
79. Murthy, V. K. & Shipp, J. C. (1979) *Diabetes* **28**, 472–478

80. Frost, S. C., Clark, W. A. & Wells, M. A. (1983) *J. Lipid Res.* **24**, 899–903
81. Wetterau, J. R. & Zilversmit, D. B. (1984) *J. Biol. Chem.* **259**, 10863–10866
82. Fernando-Warnakulasuriya, G. J. P., Eckerson, M. L., Clark, W. A. & Wells, M. A. (1983) *J. Lipid Res.* **24**, 1626–1638
83. Olefsky, J. M., Farquhar, J. W. & Reaven, G. M. (1974) *Am. J. Med.* **57**, 551–560
84. Reaven, G. M. & Greenfield, M. S. (1981) *Diabetes* **30**, Suppl. 2, 66–75
85. Gibbons, G. F. (1986) *Clin. Sci.* **71**, 477–486
86. Howard, B. V. (1987) *J. Lipid Res.* **28**, 613–627
87. Kostner, G. M. & Karádi, I. (1988) *Diabetologia* **31**, 717–722
88. Reaven, G. M. & Chen, Y.-D. I. (1988) *Diabetes/Metabolism Rev.* **4**, 639–652
89. Topping, D. L. & Mayes, P. A. (1982) *Biochem. J.* **204**, 433–439
90. Topping, D. L., Storer, G. B. & Trimble, R. P. (1988) *Am. J. Physiol.* **18**, E306–E313
91. Nikkilä, E. A. (1974) in *Regulation of Hepatic Metabolism* (Lundquist, F. & Tygstrup, N., eds.), pp. 360–378, Munksgaard, Copenhagen
92. Vogelberg, K.-H., Gries, F. A. & Moschinski, D. (1980) *Horm. Metab. Res.* **12**, 688–694
93. Pietri, A. O., Dunn, F. L., Grundy, S. M. & Raskin, P. (1983) *Diabetes* **32**, 75–81
94. Marrino, P., Gavish, D., Shafir, E. & Eisenberg, S. (1987) *Biochim. Biophys. Acta* **920**, 277–284
95. Gibbons, G. F. (1989) *Biochem. Soc. Trans.* **17**, 49–51
96. Dashit, N. & Wolfbauer, G. (1987) *J. Lipid Res.* **28**, 423–436
97. Pullinger, C. R., North, J. D., Teng, B.-B., Rifci, V. A., Ronhiid de Brito, A. E. & Scott, J. (1989) *J. Lipid Res.* **30**, 1065–1078
98. Duerden, J. M., Bartlett, S. M. & Gibbons, G. F. (1989) *Biochem. J.* **262**, 313–319
99. Duerden, J. M., Bartlett, S. M. & Gibbons, G. F. (1989) *Biochem. J.* **263**, 937–943
100. Debeer, L. J., Beynen, A. C., Mannaerts, G. P. & Geelen, M. J. H. (1982) *FEBS Lett.* **140**, 159–164
101. Nossen, J. O., Rustan, A. C., Barnard, T. & Drevon, C. A. (1984) *Biochim. Biophys. Acta* **803**, 11–20
102. Francone, O. L., Kalopissis, A.-D. & Griffaton, G. (1989) *Biochim. Biophys. Acta* **1002**, 28–36
103. Patsch, W., Franz, S. & Schonfeld, G. (1983) *J. Clin. Invest.* **71**, 1161–1174
104. Sparks, C. E., Sparks, J. D., Bolognino, M., Salhanick, A., Strumph, P. S. & Amatruda, J. M. (1986) *Metab. Clin. Exp.* **35**, 1128–1136
105. Yao, Z. & Vance, D. E. (1988) *J. Biol. Chem.* **263**, 2998–3004
106. Bartlett, S. M. & Gibbons, G. F. (1988) *Biochem. J.* **249**, 37–43
107. Patsch, W., Gotto, A. M. Jr. & Patsch, J. R. (1986) *J. Biol. Chem.* **261**, 9603–9606
108. Pullinger, C. R. & Gibbons, G. F. (1985) *Biochim. Biophys. Acta* **833**, 44–51
109. Shaheen, O., Morgan, D. W., Wilcox, H. G., Keyes, W. G. & Heimberg, M. (1982) *Endocrinology* (Baltimore) **110**, 1740–1748
110. Eaton, R. P. (1983) *Handb. Exp. Pharmacol.* **66**, 467–476
111. Edwards, P. A., Lemongello, D. & Fogelman, A. M. (1979) *J. Lipid Res.* **20**, 2–7
112. Geelen, M. J. H., Harris, R. A., Beynen, A. C. & McCune, S. A. (1980) *Diabetes* **29**, 1006–1022
113. Gibbons, G. F., Pullinger, C. R. & Björnsson, O. G. (1984) *J. Lipid Res.* **25**, 1358–1367
114. Lamb, R. G., Bow, S. J. & Wright, T. O. (1982) *J. Biol. Chem.* **257**, 15022–15025
115. Brindley, D. N. (1981) *Clin. Sci.* **61**, 129–133
116. Unger, R. H. & Orci, L. (1976) *Physiol. Rev.* **56**, 778–826
117. Hahn, P., Girard, J., Assan, R., Frohlich, J. & Kervan, A. (1977) *J. Nutr.* **107**, 2062–2066
118. Hahn, P. (1982) *Annu. Rev. Nutr.* **2**, 91–111
119. Mangiapane, E. H. & Brindley, D. N. (1986) *Biochem. J.* **233**, 151–160
120. Dich, J., Bro, B., Grunnet, N., Jensen, F. & Kondrup, J. (1983) *Biochem. J.* **212**, 617–623
121. Cole, T. G., Wilcox, H. G. & Heimberg, M. (1982) *J. Lipid Res.* **23**, 81–91
122. Sparks, J. D., Sparks, C. E. & Miller, L. L. (1989) *Biochem. J.* **261**, 83–88
123. Frayn, K. N. (1986) *Clin. Endocrinol.* **24**, 577–599
124. Brindle, N. P. J. & Ontko, J. A. (1988) *Biochem. J.* **250**, 363–368
125. Chait, A., Brunzell, J. D., Johnson, D. G., Benson, J. W., Werner, P., Palmer, J. P., Albers, J. J., Ensinnck, J. W. & Bierman, E. L. (1979) *Metab. Clin. Exp.* **28**, 553–567
126. Heimberg, M., Olubadewo, J. D. & Wilcox, H. G. (1985) *Endocrinol. Rev.* **6**, 590–607
127. Davidson, N. O., Carlos, R. C., Drewek, M. J. & Parmer, T. G. (1988) *J. Lipid Res.* **29**, 1511–1522
128. Engelken, S. F. & Eaton, R. P. (1981) *Atherosclerosis* **38**, 177–183
129. Engelken, S. F. & Eaton, R. P. (1980) *Endocrinology* (Baltimore) **107**, 208–214
130. Demmer, L. A., Levin, M. S., Elovson, J., Reuben, M. A., Lusic, A. J. & Gordon, J. I. (1986) *Proc. Natl. Acad. Sci. U.S.A.* **83**, 8102–8106
131. Green, R. P., Birkenmeier, E. H., Beamer, W. G., Maltens, L. J. & Gordon, J. I. (1988) *Proc. Natl. Acad. Sci. U.S.A.* **85**, 5592–5596
132. Davidson, N. O., Powell, L. M., Wallis, S. C. & Scott, J. (1988) *J. Biol. Chem.* **263**, 13482–13485
133. Nestel, P. J. (1973) *Prog. Biochem. Pharmacol.* **8**, 125–140
134. Zech, L. A., Boston, R. C. & Foster, D. M. (1986) *Methods Enzymol.* **129B**, 366–384
135. Farquhar, J. W., Gross, R. C., Wagner, R. M. & Reaven, G. M. (1965) *J. Lipid Res.* **6**, 119–134
136. Agius, L., Blackshear, P. J. & Williamson, D. H. (1981) *Biochem. J.* **196**, 637–640
137. Baker, N. & Schotz, M. C. (1964) *J. Lipid Res.* **5**, 189–197
138. Lipkin, E. W., Cooper, C. & Shipley, R. A. (1978) *Biochem. J.* **172**, 205–208
139. Basso, L. V. & Havel, R. J. (1970) *J. Clin. Invest.* **49**, 537–547
140. Havel, R. J., Kane, J. P., Balasse, E. O., Segel, N. & Basso, L. V. (1970) *J. Clin. Invest.* **49**, 2017–2035
141. Eisenberg, S. (1988) in *Hyperlipidaemia and Atherosclerosis* (Suckling, K. E. & Groot, P. E., eds.), pp. 65–72, Academic Press, London
142. Havel, R. J., Felts, J. M. & Van Duyn, C. M. (1962) *J. Lipid Res.* **3**, 297–308
143. Havel, R. J. (1986) *Methods Enzymol.* **129B**, 591–612
144. Quarfordt, S. H., Hanks, J., Shelburne, F. & Schirmer, B. (1982) *J. Clin. Invest.* **69**, 1092–1098
145. Kotlar, T. J. & Borensztajn, J. (1977) *Am. J. Physiol.* **233**, E316–E319
146. Baltzell, J. K. & Berdanier, C. D. (1985) *J. Nutr.* **115**, 104–110
147. Gibbons, G. F. & Pullinger, C. R. (1986) *Biochem. J.* **239**, 617–623
148. Kalopissis, A.-D., Griglio, S., Malewiak, M.-I. & Rozen, R. (1980) *Biochim. Biophys. Acta* **620**, 111–119
149. Nestel, P. J., Connor, W. E., Reardon, M. F., Connor, S., Wong, S. & Boston, R. (1984) *J. Clin. Invest.* **74**, 82–89
150. Harris, W. S. (1989) *J. Lipid Res.* **30**, 785–807
151. Daggy, B., Arost, C. & Bensadoun, A. (1987) *Biochim. Biophys. Acta* **920**, 293–300
152. Harris, W. S., Connor, W. E., Alam, N. & Illingworth, D. R. (1988) *J. Lipid Res.* **29**, 1451–1460
153. Groot, P. H. E., deBoer, B. C. J., Haddeman, E., Houtsmuller, U. M. T. & Hülsmann, W. C. (1988) *J. Lipid Res.* **29**, 541–551
154. Getz, G.-S., Soltys, P. A., Carey, K. D., McGill, H. C., Jr. & Hay, R. (1987) *Am. Heart J.* **113**, 440–445
155. Storlien, L. H., Kraegen, E. W., Chisholm, D. J., Ford, G. L., Bruce, D. G. & Pascoe, W. S. (1987) *Science* **237**, 885–888
156. Nagata, Y. & Zilversmit, D. B. (1987) *J. Lipid Res.* **28**, 684–692
157. Laker, M. E. & Mayes, P. A. (1984) *Biochim. Biophys. Acta* **795**, 427–430
158. Windmueller, H. G. & Spaeth, A. E. (1967) *Arch. Biochem. Biophys.* **122**, 362–369
159. Williamson, D. H. (1989) *Biochem. Soc. Trans.* **17**, 37–40
160. Weiland, D., Mondon, C. E. & Reaven, G. M. (1980) *Diabetologia* **18**, 335–340
161. Berry, E. M., Ziv, E. & Bar-On, H. (1981) *Diabetologia* **21**, 402–408
162. Otway, S. & Robinson, D. S. (1967) *J. Physiol. (London)* **190**, 321–332
163. Risser, T. R., Reaven, G. M. & Reaven, E. P. (1978) *Am. J. Physiol.* **234**, E277–E281
164. Palmer, J. F., Cooper, C. & Shipley, R. A. (1978) *Biochem. J.* **172**, 219–226
165. Risser, T. R., Reaven, G. M. & Reaven, E. P. (1978) *Diabetes* **27**, 902–908
166. Huang, M.-T. & Williams, M. A. (1980) *Am. J. Physiol.* **238**, E499–E505

167. McBurney, L. J. & Radomski, M. W. (1969) *Am. J. Physiol.* **217**, 19–23
168. Kannan, R., Learn, D. B., Baker, N. & Elovson, J. (1980) *Lipids* **15**, 993–998
169. Witztum, J. L. & Schonfeld, G. (1979) *Diabetes* **28**, 509–516
170. Marsh, J. M. (1986) *Methods Enzymol.* **129B**, 498–519
171. Durrington, P. N., Newton, R. S., Weinstein, D. B. & Steinberg, D. (1982) *J. Clin. Invest.* **70**, 63–73
172. Strobl, W., Gorder, N. L., Fienup, G. A., Lin-Lee, Y. C., Gotto, A. M. & Patsch, W. (1989) *J. Biol. Chem.* **264**, 1190–1194
173. Howard, B. V., Abbott, W. G. M., Egusa, G. & Taskinen, M.-R. (1987) *Am. Heart J.* **113**, 522–526
174. Sparks, J. D., Sparks, C. E., Bolognino, M., Roncone, A. M., Jackson, T. K. & Amatruda, J. M. (1988) *J. Clin. Invest.* **82**, 37–43
175. Nikkilä, E. A. & Kekki, M. (1973) *Metab. Clin. Exp.* **22**, 1–22
176. Ginsberg, H., Mok, H., Grundy, S. & Zech, L. (1977) *Diabetes* **26**, Suppl. 1, 399
177. Greenfield, M., Kolterman, O., Olefsky, J. & Reaven, G. M. (1980) *Diabetologia* **18**, 441–446
178. Arbeeny, C. M., Edelstein, D., Freedman, S. R. & Eder, H. A. (1980) *Diabetes* **29**, 774–777
179. Feingold, K. R., Lear, S. R. & Moser, A. H. (1984) *Diabetologia* **26**, 234–239
180. Popper, D. A., Shiau, Y.-F., & Reed, M. (1985) *Am. J. Physiol.* **249**, G161–G167
181. Egusa, G., Beltz, W. F., Grundy, S. M. & Howard, B. V. (1985) *J. Clin. Invest.* **76**, 596–603
182. Kesäniemi, Y. A., Beltz, W. F. & Grundy, S. M. (1985) *J. Clin. Invest.* **76**, 586–595
183. Kissebah, A. H., Alfarsi, S. & Adams, P. W. (1981) *Metab. Clin. Exp.* **30**, 856–868
184. Ong, J. M. & Kern, P. A. (1989) *J. Clin. Invest.* **84**, 305–311
185. Wang, S. R., Infante, J., Catala, D., Petit, D., Bonnefis, M. F. & Infante, R. (1989) *Biochim. Biophys. Acta* **1002**, 302–311
186. Abbott, W. G. M., Lillioja, S., Young, A. A., Zawadki, J. K., Yki-Järvinen, H., Christin, L. & Howard, B. V. (1987) *Diabetes* **36**, 897–904
187. Cruse, J. R. & Grundy, S. M. (1984) *J. Lipid Res.* **25**, 486–496
188. Taskinen, M.-R., Nikkilä, E. A., Välimäki, M., Sane, T., Kuusi, T., Kesäniemi, Y. A. & Ylikahri, R. (1987) *Am. Heart J.* **113**, 458–464
189. Baraona, E. & Leiber, C. S. (1970) *J. Clin. Invest.* **49**, 769–778
190. Savolainen, E. M., Baraona, E., Karsenty, C. & Leiber, C. S. (1982) *Hepatology* **2**, 681
191. Venkatesan, S., Ward, R. J. & Peters, T. J. (1988) *Biochim. Biophys. Acta* **960**, 61–66
192. Cairns, S. R. & Peters, T. J. (1984) *Clin. Sci.* **67**, 337–345
193. Grunnet, N., Jensen, F., Kondrup, J. & Dich, J. (1985) *Alcohol* **2**, 157–161
194. Soutar, A. K. (1989) *Nature (London)* **341**, 106–107