



THE UNIVERSITY *of* EDINBURGH

Edinburgh Research Explorer

Assessment of Distribution Network Limits for Non-firm Connection of Renewable Generation

Citation for published version:

Boehme, T, Harrison, G & Wallace, R 2010, 'Assessment of Distribution Network Limits for Non-firm Connection of Renewable Generation', *IET Renewable Power Generation*, vol. 4, no. 1, pp. 64-74. <https://doi.org/10.1049/iet-rpg.2008.0109>

Digital Object Identifier (DOI):

[10.1049/iet-rpg.2008.0109](https://doi.org/10.1049/iet-rpg.2008.0109)

Link:

[Link to publication record in Edinburgh Research Explorer](#)

Document Version:

Peer reviewed version

Published In:

IET Renewable Power Generation

Publisher Rights Statement:

"This paper is a postprint of a paper submitted to and accepted for publication in IET Renewable Power Generation and is subject to Institution of Engineering and Technology Copyright. The copy of record is available at IET Digital Library"

General rights

Copyright for the publications made accessible via the Edinburgh Research Explorer is retained by the author(s) and / or other copyright owners and it is a condition of accessing these publications that users recognise and abide by the legal requirements associated with these rights.

Take down policy

The University of Edinburgh has made every reasonable effort to ensure that Edinburgh Research Explorer content complies with UK legislation. If you believe that the public display of this file breaches copyright please contact openaccess@ed.ac.uk providing details, and we will remove access to the work immediately and investigate your claim.



Assessment of Distribution Network Limits for Non-firm Connection of Renewable Generation

Thomas Boehme¹, Gareth P. Harrison* and A. Robin Wallace

*Corresponding author

Address:

Institute for Energy Systems
School of Engineering
University of Edinburgh
Mayfield Road
Edinburgh EH9 3JL

Email addresses:

Thomas.Boehme@dnv.com
Gareth.Harrison@ed.ac.uk
Robin.Wallace@ed.ac.uk

Abstract

Before new renewable generators can be connected to the electricity network it is necessary to carefully evaluate the impact they will have. Firm connection agreements are based on snapshot assessments of the worst case situation of maximum generation and minimum demand which restrict renewable capacities despite infrequent occurrence. This work describes how time series of several renewable generation technologies together with demand can be applied to examine the opportunities and challenges offered by non-firm generation connections. It applies optimal power flow to extract maximum energy from available renewable resources whilst using curtailment of generation to maintain the network within thermal and voltage limits. By way of a case study of potential wind, wave and tidal current development in the Orkney Islands, Scotland, the analysis provides estimates for the degree of curtailment and consequent economic impact a renewable generator operating under non-firm connection may experience. The methods described provide a first-level analysis that could facilitate appraisal of non-firm connections at the planning stage by estimating the consequences of concurrent generation and demand as well as the frequency and duration of necessary curtailments.

Keywords: Distributed generation, power flow analysis, optimal power flow, renewable energy generation, time series.

¹ Dr Thomas Boehme is now with Det Norske Veritas, London.

1 Introduction

Onshore wind farms are often sited in areas where the electricity network is weak and offshore wind, wave and tidal energy projects may experience similar problems at the onshore connection point. The variable nature of renewable resources causes power output to change at time scales from seconds to hours, exhibiting daily and seasonal patterns. Active power generation and reactive power consumption (or generation) cause variations in network voltages and changes in the loading of components. These impacts, as well as protection, stability and power quality are assessed by Distribution Network Operators (DNOs) when a connection application is filed [1]; voltage, thermal and fault level constraints tend to be the most serious issues.

The policy of 'fit-and-forget' for distributed generation (DG) connections traditionally used by DNOs requires DG to be able to output full capacity regardless of network configuration or security condition (typically N-1); such connections are termed 'firm'. Assessment of connections focuses on the critical conditions to be experienced in the network which normally occur when high generation levels coincide with low demand levels. Such an approach is regarded as reasonable for non-variable energy sources where the maximum output is sustained for extended periods although it remains a significant constraint on DG capacity [2]. For variable renewable generation, however, the local wind, wave or tidal resource and the chosen energy converter characteristics mean that nameplate output may be produced more or less frequently. As such, the worst case situation of low demand and high generation will tend to occur for a relatively small fraction of time. Firm connections would require that the nameplate capacity be restricted despite the opportunity for much higher energy delivery. Curtailment of renewable generation through trimming output or tripping units during low demand periods is one option for ensuring that network parameters remain within limits [3], [4]. This enables larger generators to be connected albeit at the expense of lost production and potentially an adverse effect on the financial viability of the project [3]. To effect this, the renewable developer would enter into a 'non-firm' connection agreement wherein the DNO reserves the right to reduce the output of the renewable farm by means of an active network management system.

Determining the impact of such connection arrangements is more complex than with the traditional 'snapshot' assessment at critical conditions. Statistical analysis of recorded data can give a resource probability curve for initial assessment of the situation, but concurrent demand levels need to be taken into account as well. Using long-term load records, this can be assessed in simple cases such as for a single wind farm. However, when several wind farms feed into the system at various points, detailed network analysis is necessary to account for the differences in output between wind farms at any given moment. The correlation of the output of the wind farms is a complex matter, but the application of time series has been demonstrated to give useful results [5]. Introducing other

renewable energy technologies such as wave and tidal current energy increases the complexity of the problem significantly.

This paper expands on earlier work [6] and describes how time series of several renewable generation technologies together with demand can be applied to examine non-firm connections. It applies optimal power flow (OPF) analysis to selectively curtail renewable generation and extract the maximum amount of energy from available resources within the thermal and voltage limits of the network. The analysis also provides estimates for the degree of curtailment and consequent economic loss a renewable generator operating under non-firm or constrained connection may experience. The methods described below could facilitate the parties involved in appraising such connections at the planning stage by estimating the consequences of concurrent generation and demand as well as the frequency and duration of necessary curtailments.

The paper is set out as follows. Section 2 contrasts the traditional snapshot approach to the connection assessment process with sophisticated methods based on time behaviour and power or optimal power flow analyses. Section 3 presents a detailed case study of the Orkney Islands, Scotland to investigate how detailed multi-renewable resource assessments can be applied to investigate the behaviour of the distribution network under an active management scheme based on generation curtailment. Finally, sections 4 and 5 discuss the merits of the approaches demonstrated and draw conclusions.

2 Assessment of Non-Firm Connections

The established practice of snapshot power flow analysis for assessing connections works well with firm thermal generation and at low penetration levels of renewable generation. In networks with high renewable penetration levels, however, power flows and voltage will vary widely together with the resource. In these circumstances employing concurrent time series for generation and demand can provide additional benefits beyond those offered by ‘winter’ and ‘summer’ snapshot analysis [5]. The time-domain information can then be statistically analysed or condensed into duration curves. As a result, the long-term loading situation will be known and particular time steps which represent problematic network conditions can be further investigated. Conventional AC power flow simulation will not attempt to modify the active power output of generators and, therefore, unacceptable overloading of branches and transformers or over/under voltages may occur at times. Optimal power flow analysis can address this.

OPF minimises a function $F(x, u)$ subject to a set of non-linear equality constraints $g(x, u) = 0$ (i.e. the power flow equations) and a set of non-linear inequality constraints $h(x, u) \leq 0$, where x represents dependent variables (such as bus voltage magnitude and angle) and fixed parameters (such as fixed output and line parameters) and u control variables (such as real power generation and tap settings) [7]. Typical constraints include limits on control variables, generation/load balance and branch flow

limits. The property traditionally minimised in OPF is fuel cost with a view to defining the most economic dispatch of thermal and/or hydro units. Although the renewable sources discussed here do not use fuel, the plant can be similarly ranked by a pseudo-merit order. This mimics the practice of non-dispatchable renewable production taking precedence over dispatchable sources with the renewable sources generating up to the level that the resource allows at the particular time. The optimal power flow analysis can then make sure that no voltage or branch flow limits are violated. A wide range of commercial power systems software suites incorporate OPF and several solution methods are used. For example, the well-established PSS/E software used in this work employs an interior point solution method [8]. OPF has typically been applied in transmission planning and operations but it has yet to find widespread usage within DNOs. In academic research it has been shown to be effective in distribution network analyses when, for example, applying it to determine firm capacity limits across part of the Scottish network [2]. Further information on OPF can be found in [7].

Figure 1 shows the progression from simple snapshot power flow analysis to time series power flow and OPF. A very simple three bus network is used with swing bus 1, a 10 MW wind farm at bus 2, and a load at bus 3. For simplicity, only the voltage of the swing bus is controlled and transformers are omitted. In Fig. 1a the load is set to winter peak demand of 12 MW and the wind farm to an output of 6 MW at unity power factor. A standard AC power flow solution indicates that branch 2-3, which has a lower rating than the other two, is heavily loaded. In Fig. 1b the dimension of time is introduced and, with renewable generation and load varying, the swing bus generator output varies as well. The figures shown within the circuit diagram apply to one specific time step indicated by the dashed line in the small time plots. At this time step branch 2-3 is overloaded by 11% due to high load demand coinciding with high renewable output. To avoid the overload, the wind farm output needs to be reduced to such a value that all parameters stay within prescribed limits (in this case branch thermal rating is the constraint). Fig. 1c shows the same time series being applied to the network but this time solved using OPF with the renewable generator at low 'cost' and the swing bus at high 'cost' to encourage the OPF to accommodate as much of the wind farm output as possible. Compared to 1b, the generation time plot is slightly modified by the OPF algorithm around the time indicated by the dashed line as wind farm output is reduced to constrain power flows on branch 2-3 below the thermal limit (the 97% loading shown is an average along the branch but OPF ensures that limits are not exceeded at either end). The swing generator output is shown to correspondingly increase at that time to balance the system. The ideas from this simple example are applied in the following detailed case study.

3 Orkney Islands Case Study

3.1 Orkney System

The area of Orkney, Scotland, UK possesses excellent wind, wave and tidal current resources and offers a useful, relatively small-scale case study for exploring their combined impact on the electricity distribution network. Fig. 2 shows a map of the Orkney region. The islands are connected to the Scottish mainland by two 33 kV undersea/overhead circuits of 23.4 and 26 MVA average rating which have been in continuous operation since 1982 and 1998, respectively [4]. A 275 kV overhead line from the south terminates at the coastal town of Dounreay. The area is of high interest to wind farm developers and a number of smaller projects have already been installed. In addition, the European Marine Energy Centre (EMEC) operates wave and tidal test centres on Orkney. The electricity network is currently the limiting factor for renewable developments on the islands [9]. Further constraints include areas with high environmental sensitivity, airport radar systems (for wind turbines) and areas of high navigational risk (for marine energy converters) [10].

Fig. 3 shows a simplified view of the 33 kV distribution system of the Orkney region [11], [12]. The lower voltage network parts are represented by equivalent loads with peak (winter) demand indicated. The network model extends further south where, in this study, the swing bus generator was connected at 275 kV. The Orkney gas, diesel, and wind power plants in place by the end of 2006 and the marine test centres are all shown. The test centres have connection agreements for several megawatts but average utilisation is lower; 2 MW installed capacity each was assumed. In addition, a 30 MW wind farm, a 30 MW wave farm and a 15 MW tidal current farm were connected to study their prospective impact and the network limitations.

Based on the DNO's documentation [12], existing generators were modelled in either PV or PQ mode. Operation of additional ('new') generators was assumed at unity power factor even though many modern machines will be able to act on specific conditions in the network. The simulated network contained 140 bus bars, 40 generators, 35 loads, 115 branches, 50 tap changing transformers, and 4 adjustable shunts.

Until recently generators on Orkney were given firm connection agreements, i.e., they are able to operate without constraint [4]. In this study all existing generators and consented wind farm extensions were assumed to retain firm connection, apart from the 11 MW Spurness wind farm which was constrained when necessary. The Flotta gas turbine schedule was modelled according to information from the DNO. When one subsea cable is out of service it is not possible to operate all existing Orkney generation without the Kirkwall diesel generators stabilising the system [4]. The diesel generators are not, however, designed to serve in a hybrid system and so their ramp rates or minimum up/down time were not relevant to this study. As diesel generators are designed to operate with a significant load, the Kirkwall generation must supply an appropriate amount of active power

whenever a contribution of reactive power is needed. In addition, fixed and adjustable reactive power compensation is connected within the network at several places as shown in Fig. 3. Large wind farms were also modelled on the Scottish mainland to reflect the number of applications for planning permission. To ensure consistency with the conservative assessment in [10] and in common with many project appraisals, the hourly output of all renewable projects was reduced by 5% across the year to account for planned and unplanned maintenance.

3.2 Renewable Resources

Time series for all generators' output were calculated and applied on an hour-by-hour basis. These were extracted from a highly detailed multi-renewable resource database covering Scotland's on- and offshore wind, wave and tidal resources at a resolution of 1 km² on an hourly basis over the three years from 2001 to 2003 [10]. Long-term wind data for several met stations in the Orkney region was available from the UK Met Office. The time series production for each wind farm were derived from this using the microscale modelling software Wind Atlas Analysis and Application Program (WAsP) [13], and the hub height and power curve of the installed turbines. For new wind farms a typical power curve of a 2.5 MW machine was used [14]. Greater detail on this process is given in [5] and especially [15]. Offshore wind and wave data is available from the UK Waters Wave Model operated by the Met Office. Its temporal and spatial resolution requires some interpolation [10]. Offshore wind could be developed in shallow waters in northern Orkney, but due to the limited network capacity only a small farm was modelled off the coast of Dounreay and connected on the mainland. Wave energy converters were placed in a location where the waves arrive from westerly and north-westerly directions and are the least affected by shallower waters in the region. To obtain estimates of wave energy production, it was necessary to employ a power matrix for possible combinations of wave height and period [16]. There are a number of locations on Orkney which are suitable for the extraction of tidal current energy. A good location near Hoy that possessed bidirectional tidal flows was chosen and the power curve of a fully submerged, twin-rotor, tidal current turbine was applied [17]. Tidal velocities were estimated using the Totaltide tidal prediction software [18] along with additional consultation of published tidal atlases such as [19].

Fig. 4 shows the typical seasonal plant capacity factors applicable to the Orkney region. The on- and offshore wind is stronger in winter than in summer, although calm periods during winter have an appreciable effect on electricity production. The daily summer profile of onshore wind shows a typical increase of wind speeds around mid-day due to thermal effects. Offshore, the turbines can produce more, especially in winter. The annual profile of wave energy production resembles that of wind although summer output can be very low, while winter output is comparably high and the daily profiles are essentially flat. In contrast to the other forms of energy discussed, tidal current energy is fully predictable. The Orkney region experiences two tidal cycles in the lunar day. The slight

mismatch between this and the solar day produces flat histograms, even though the tidal energy converter may produce zero and rated power four times each lunar day.

3.3 Time Series Power Flow Analyses

A matching set of hour-by-hour demand time series were made available by the DNO and full power flow analyses were carried out for every hourly time step from the very start of January 2001 to the end of December 2003, i.e., 26,280 time steps in total. To achieve this, the process was fully automated using the commercial software package PSS/E (v. 30) by way of scripts written in its IPLAN programming language. The results of each time step were automatically extracted and collated and included bus voltages, generator output, branch/transformer loading and shunt setting. For monitoring purposes the overall system mismatch, the number of iterations and results of error checks were logged as well. Each hour is simulated separately and there is no requirement to optimise across periods as might be necessary with hydro storage or thermal scheduling problems.

Initial simulations showed quickly that the undersea cable connections between Orkney and the mainland are a limiting factor for any further development of renewable generation on the islands. Depending on the power factor on the load end of the cable, the capacity for active power can be as low as 10 or 20 MW for the cases with one or both cables intact. In this study failure of the stronger of the two cables represented the N-1 case, i.e., that all circuits except that cable were intact. Other N-1 cases could also be considered, especially failures in the main loop connecting most of the islands, but this was not attempted here.

3.3.1 Power Flow

Prior to the simulation of each hourly time step, active and reactive power were set for all loads. Based on the current renewable resources the generator active power level and, depending on the operational mode, reactive power, were set. Branch capacity was set to values implied by published seasonal ratings. AC power flow does not take into account the rating, but relative loading of a branch is reported based on the value set. To obtain repeatable results, transformer tap changers were initially set to the same nominal position, otherwise this would not be necessary.

Test runs showed that sequential application of the Gauss-Seidel and Newton-Raphson power flow algorithms performed best and scripts for employing these with appropriate options (e.g., tap changing enabled) were developed. To check whether the simulation converged, the total system mismatch and bus voltages were read back and, if within limits, results were saved and the simulation advanced to the next time step. With a very large over-capacity (65 MW) of 'new' generation on the Orkney network, the simulation would not converge initially for a large number of time steps. To solve the convergence issue, the first measure was then to enable active power output of the Kirkwall diesel generator to deliver the corresponding range of reactive capability. If this measure did not lead to

convergence, then the output of all new renewable projects was reduced in small steps and simulations were re-run, starting again with the Kirkwall generators off. This was repeated until convergence was achieved for each time step.

While time series AC power flow can give many useful results [5] there are two main limitations: (a) despite successful convergence the branches may be overloaded, and (b) all non-firm generators' output is arbitrarily reduced by the same fraction. Application of optimal power flow addresses these issues.

3.3.2 *Optimal Power Flow*

The process of applying OPF across the time series is outlined schematically in Figure 5. The standard OPF was applied to dispatch the new wind, wave and tidal generators, the swing bus generator and the Spurness wind farm (where essential). Existing thermal and renewable generation was not dispatched and produced according to schedule or resource potential. To control generator dispatch and curtailment, arbitrary 'fuel' costs were assigned to the renewable generators with the OPF objective to minimise the overall 'cost' while allowing the generators to generate as appropriate to the maximum extent. The 'costs' are simple multipliers such that the objective function takes the form $f = \min \sum_g c_g P_g$ where c is the 'cost' per unit output P of generator g . As an existing scheme, the Spurness wind farm is only constrained where essential and not curtailed in favour of the new generation. To ensure this a low, constant, cost of '1' was assigned to this wind farm while the three new renewable projects were assigned a higher cost of '10'. To find the potential of the islands to be self-sufficient, high costs of '100' were assigned to the swing bus located on the mainland to discourage imports.

As Figure 5 shows, in each time step, component parameters are set as for AC power flow with the exception of non-firm renewable generators. Their maximum output rating, not the actual output value, is set to the potential power production derived from the renewable resource. In this way each renewable generator's output will be chosen by the OPF to lie between zero and the maximum possible for the particular time step. The minimum and maximum generation levels of the swing bus were not modified.

Other than generation, the OPF analysis respects constraints such as daily branch and transformer flow limits derived from applicable seasonal values, as well as voltage limits for each bus. The OPF solution was further influenced by initially only enabling the three new renewable projects for dispatch. Part of the automated script dealt with cases where no solution could be initially obtained by (a) incrementing the Kirkwall diesel generator reactive capabilities and active power output and (b) including the Spurness wind farm in the dispatch to constrain it. This situation occurred infrequently across the period analysed. Together the combination of OPF and programming determined the

maximum renewable generation that could be tolerated for each connection for each hour in the three year period modelled.

3.4 Example Time Series

With the analysis extending over three years it is not feasible to present the full detail of the time series of production and power flows (although a partial summary is given in the next subsection). The results of the simulations for one representative winter week in January 2003 are given in Figures 6 and 7. They depict unconstrained potential active power output of the renewable projects together with results from the AC power flow and OPF analyses. The results are for the N-1 condition with the stronger of the subsea cables to the mainland out of service. The Spurness wind farm (Fig. 6a) is rarely constrained, but in the case of production from the EMEC tidal centre, the OPF algorithm reduces the output of the wind farm in order not to exceed local subsea cable ratings. Rated power is reached several times during the week, but zero output also occurs.

The simulations show that a 30 MW onshore wind farm (Fig. 6b) could, in practice, not be connected as indicated in Fig. 3. Even during AC power analysis its output needs to be reduced to obtain a network solution. OPF further constrains the farm because some of the overhead circuits would otherwise be overloaded. The wave farm (Fig. 6c) has a more favourable connection point (closer to the Scorradaale substation) and can use the island's export capability more directly. The week shown coincided with a spring (strong) tide and the tidal project (Fig. 6d) experiences frequent requests to reduce output. This is due to both branch overloading and voltage violations. The latter could be mitigated to some extent by using energy converters or other actively managed network components able to produce and consume reactive power [20]-[22].

Fig. 7 shows the results as 'stacked' energy curves to compare renewable generation with total demand on the islands. In this week, the modelled projects appear to be able to supply the islands with sufficient renewable energy to meet demand most of the time. However, at other times of the three-year period the renewable output was much lower. Power flow analysis shows that significant curtailment of non-firm generation is required to ensure feasible power flow solutions. OPF reduces the output further to keep parameters within thermal and statutory voltage limits. For the N-1 case pictured, little more than 10 MW can be exported from Orkney to the mainland. Comparing Figures 7b and 7c it can be seen that the AC power flow algorithm reduces the new projects' output in proportion while OPF makes more selective reductions as required at particular locations.

The impact of the OPF on selected network power flows and voltages can be seen in Figure 8. The top two traces show the power flows through (a) the 20 MVA Scorradaale voltage regulator (transformer) serving the 23.4 MVA subsea cable between Orkney and the mainland and (b) the 12 MVA subsea cable from Shapinsay to Bu in the east of Orkney (as indicated in Fig. 3). The power flow and OPF

traces closely follow those of the generation profiles of Figures 6 and 7 and the overloading of the two components in the power flow case is evident. The action of the OPF in containing the power flows within the component ratings is also clearly illustrated.

Figure 8c shows the voltage time series at Burger Hill. The power flow trace shows that the voltage is highly variable as it responds to demand and production, transformer tap activity and the interventions from the Kirkwall diesel gensets and/or the arbitrary output reductions. It is evident that many of the periods with low voltages coincide with reduced wind farm output (Fig. 6b) and asset loading (Fig. 8); and there are also periods where voltage exceeds the statutory limits. It is more difficult to directly compare the power flow and OPF voltage traces given the difference in activity from the Kirkwall diesels and the more subtle control exerted by the OPF. In maximising export from the Burger Hill area the OPF constrains voltages to the maximum level allowed for much of the period. The activity of the OPF can clearly be seen in the series of notches in the trace which indicate that, at times, there was insufficient local generation to result in significant voltage rise.

3.5 Power System Implications

While the time series are useful in indicating the impact of short term fluctuations in renewable potential (and demand), longer term summaries of network conditions are enlightening. The output of the power flow and OPF simulations were processed to indicate the degree of overloading of branches and voltage violation that the new renewable generation can cause. Fig. 9 shows load duration curves for the two components selected earlier: (a) the Scorradales voltage regulator and (b) the Shapinsay to Bu subsea cable. Several curves are presented both for an intact system (case 'N') and a faulted system (N-1) as well as power flow with just the existing generation connected (PF_e), as well as power flow (PF_a) and OPF with the all new generation connected (65 MW).

For the case that all existing capacity has firm connection, the voltage regulator at the end of the subsea cable to the mainland would infrequently be overloaded under fault conditions (Fig. 9a). If the new generators were present, then dispatch based on normal power flow analysis would result in unacceptable overloading conditions. OPF rectifies this as it can be seen to cap transformer loading to its rating. Coincident high output from the wind farms and the tidal test centre in the north-east of the Islands will cause some overloading of the subsea cables to Shapinsay (Fig. 9b). Curtailment of Spurness wind farm output would then be necessary to alleviate this. Similar diagrams can be produced for voltage variations and the effectiveness of control measures could be investigated by improving voltage control of the renewable generators.

3.6 Economic Impact of Constraints

With the existing levels of generation, Orkney is a net importer of electricity most of the time with limited need for generator curtailment. This would change if large new projects were developed. As

demonstrated here, extensive curtailment would be necessary having a significant impact on the plant capacity factor and return on investment.

Fig. 10 shows the impact of curtailment on the annual output of the Spurness wind farm and the three new renewable projects. Output duration curves are given for the unconstrained case which developers would expect to realise, as well as for power flow and optimal power flow for both intact and faulted systems. The Spurness wind farm represents a situation where a project has to operate in a constrained environment. The annual production losses for the 'N' case amount to 6%, mostly due to simultaneous high output from the tidal test centre. Due to an unsuitable connection point, the new onshore wind farm would experience production losses of 49% even with an intact network. The year-to-year variation across 2001 to 2003 is indicated in Fig. 10b for case 'N': the spread emphasises that one year of data is the very minimum to be used in such a study.

The wave farm will be constrained at some times resulting in production losses of 5% if the network is intact throughout the year. The tidal current farm would experience severe curtailment and lose 24% of production due to network overloading and voltage constraints although voltage control by the tidal turbines themselves could potentially reduce this [21].

4 Discussion

The approach provides a first-level appraisal of non-firm connections at the planning stage by estimating the consequences of concurrent generation and demand as well as the frequency and duration of necessary curtailments. The case study has demonstrated that time series of demand and renewable generation could conveniently be applied in power system analysis to determine the impact on voltage levels and the loading of branches and transformers with power flow analysis identifying areas requiring network upgrades. The analysis also provides estimates for the degree of curtailment and consequent economic loss a renewable generator operating under non-firm or constrained connection may experience. The assessment is understood to be one of the first to demonstrate the impact of marine energy technologies in a significant manner.

It is important to emphasise that in order to explore the power system limits and to trigger significant curtailment visible in the resulting graphs, the new renewable generation capacity modelled is much larger than could sensibly be deployed and, in practice, none of the three projects would be built with the chosen capacities. The DNO expects that only 10-15 MW of new connections are currently feasible which reflects the local network but also constraints in the transmission system [23].

The analysis indicates that with non-firm connections, the choice of installed capacity for a renewable generator is very important for its financial viability. Determining an 'optimal' capacity is not straightforward as production is uncertain due to the activity of other connected generators and

potentially by subsequent installations that can ‘eat into’ export limits. One option is to re-run the analysis with a series of different capacities at each location to examine the degree of curtailment and export relative to the capital investment. For anything other than a relatively few simulations this would be a time consuming exercise. An alternative is to build off earlier work using OPF to select the ‘optimal’ DG capacity [2] as extended to multi-period analysis [24] to allow consideration of overall curtailment volumes. The challenge then is to appropriately capture the inter-relationships between demand and the resources across all time periods [5].

Many non-firm connections may operate under a ‘last-in first-out’ arrangement wherein earlier connected plant has some degree of priority over newer applications. To some extent this arrangement was demonstrated here by prioritising the Spurness wind farm by assigning a lower ‘cost’. The logical extension of this would see different costs assigned to generators according to when they connected. This arrangement has some similarities with firm connections operating on a ‘first come first served’ basis and work to investigate the impact of priority schemes on the ability of the network to accommodate generating capacity appears to be warranted.

The hourly assessment used here is a reasonable guide to conditions within the hour, although particularly with wind and, to a lesser extent wave and tidal, there will be variations in output as well as fluctuations in demand levels. Sub-hourly resource estimation would be necessary to improve estimates of operation and curtailment and even greater levels of detail are required for real-time control.

A first-generation active management system has now been installed on Orkney to allow greater connection whilst ensuring compliance with thermal constraints on the subsea cable infrastructure within the system and to the mainland [25]. It uses real-time measurements of power flows and a logic-based inter-tripping scheme to determine the active power set-points for key generators. An alternative approach to active management incorporating a wider range of constraint considerations and control functionality could be implemented using an OPF-based optimal dispatch system along with measurements, state estimation [26] and potentially resource and demand forecasts. The opportunities offered by greater voltage control have not been determined here as the PSS/E OPF unfortunately offers limited opportunity for user-defined generator reactive capabilities. Further work to implement bespoke OPF routines is underway to address this issue. Additional opportunities to enhance penetration would include incorporating dynamic ratings of overhead lines and subsea cables (by evaluating thermal behaviour) as well as the use of demand side management and energy storage.

The approach is primarily aimed at assessment of local or regional distribution networks. As such, and with modest renewable penetration nationally and with reasonably strong transmission connection, the impact of power fluctuations on thermal power station response and constraints can be

neglected. Should such analysis be conducted across a wider area and with high overall penetration then consideration of thermal unit ramp rates and potential demand response would be important. Additionally, unit commitment and scheduled flow could be included but would necessarily complicate the solution.

The method presented in this paper is quite demanding to implement, but it removes the somewhat arbitrary judgments associated with the maximum generation/minimum load approach. Both utilities and renewable project developers could gain from its application at the planning stage and project revenues can be estimated with greater confidence.

5 Conclusions

This paper describes how time series of several renewable generation technologies together with demand can be applied to examine the opportunities and challenges offered by non-firm generation connections. It applies optimal power flow-based curtailment of renewable generation to allow extraction of the maximum amount of energy from available resources within the thermal and voltage limits of the network. The analysis also provides estimates for the degree of curtailment and consequent economic loss a renewable generator operating under non-firm or constrained connection may experience. The methods provide a first-level analysis that could facilitate appraisal of non-firm connections at the planning stage by estimating the consequences of concurrent generation and demand as well as the frequency and duration of necessary curtailments.

6 Acknowledgments

This work was supported in part by the research contract QLC 11/1 from the Scottish Executive and through the Supergen Marine Energy consortium funded by the Engineering and Physical Sciences Research Council. Data were provided by Scottish and Southern Energy, Perth, and the UK Met Office, Exeter. The map shown is based on UK Crown copyright material supplied through EDINA, www.edina.ac.uk. PSS/E is a trademark of Siemens PTI. The authors acknowledge the support from the Scottish Funding Council for the Joint Research Institute with Heriot-Watt University as part of the Edinburgh Research Partnership in Engineering and Mathematics (ERPem).

7 References

- [1] 'Guidance Note for the Connection of Wind Farms, issue no. 2.1.4' (Scottish Power Transmission and Distribution and Scottish Hydro-Electric, Dec. 2002)
- [2] Harrison, G. P. and Wallace, A. R.: 'OPF evaluation of distribution network capacity for the connection of distributed generation', *IEE Proc. Gener. Transm. Distrib.*, 2005, 152 (1), pp. 115-122
- [3] Liew, S. N. and Strbac G.: 'Maximising penetration of wind generation in existing distribution networks', *IEE Proc. Gener. Transm. Distrib.*, 2002, 149 (3), pp. 256-262
- [4] Scottish Hydro-Electric Power Distribution Ltd and University of Strathclyde: 'Facilitate Generation Connections on Orkney by Automatic Distribution Network Management' (Department of Trade and Industry, 2004)
- [5] Boehme, T., Wallace, A. R. and Harrison G. P.: 'Applying Time Series to Power Flow Analysis in Networks with High Wind Penetration', *IEEE Trans. Pwr. Sys.*, 2007, 22 (3), pp. 951-957
- [6] Boehme, T., Harrison, G. P. and Wallace, A. R.: 'Assessment of Network Limits with High Wind Penetration', 7th Intl. Workshop on Large Scale Integration of Wind Power, May 2008, Madrid, Spain
- [7] Wood, A. J. and Wollenberg, B. F.: 'Power Generation, Operation, and Control' (Wiley, 2nd edn, 1996)
- [8] Siemens PTI: 'PSS/E OPF Manual' (Siemens PTI, 2005)
- [9] Bowker, J.: 'SSE opens markets to Orkney power', *The Scotsman*, 15 April 2006, pp. 30
- [10] Boehme, T., Taylor, J., Wallace A. R. and Bialek, J.: 'Matching Renewable Electricity Generation with Demand' (Scottish Executive, Edinburgh, Feb. 2006, available online at www.scotland.gov.uk/Publications/2006/04/24110728/0, accessed Nov. 2008)
- [11] Scottish Hydro-Electric Transmission Ltd.: 'Seven Year Transmission Statement 2004 - for the Years 2004/2005 to 2010/2011' (SHELTL, Perth, 2004)
- [12] Scottish Hydro-Electric Power Distribution Ltd.: 'Long Term Development Statement for Scottish Hydro Electric Power Distribution Ltd's Electricity Distribution System' (SHEDL, Perth, 2004)
- [13] Risø DTU: 'Wind Atlas Analysis and Application Program' (Risø DTU, Roskilde, Denmark, www.wasp.dk, accessed on Nov. 2008)
- [14] Nordex Energy GmbH: 'N80/2500 kW wind turbine data sheet'. (www.nordex-online.com, accessed Nov. 2008)
- [15] Boehme, T., Wallace, A. R.: 'Hindcasting Hourly Wind Power across Scotland based on Met Station Data', *Wind Energy*, 2007, 11 (3), pp. 233-244
- [16] Pelamis Wave Power Ltd.: 'Pelamis P-750 Wave Energy Converter: product data sheet', (PWP Ltd, Edinburgh, 2003)
- [17] Marine Current Turbines Ltd.: 'Seagen marine current turbine' (www.marineturbines.com, accessed Nov 2008)
- [18] UK Hydrographic Office: 'Admiralty Totaltide Product Brochure' (UKHO, Taunton, www.ukho.gov.uk/amd/Attachments/brochures/tt.pdf, accessed on 27 November 2008)
- [19] UK Hydrographic Office, 'Admiralty Tidal Stream Atlas: Orkney and Shetland Islands NP 209' (UKHO Taunton, 4th edn, 1986)
- [20] Shafiu, A., Bopp, T., Chilvers, I. and Strbac G.: 'Active management and protection of distribution networks with distributed generation', *IEEE Power Eng. Soc. General Meeting*, June 2004, pp. 1098-1103
- [21] Kiprakis, A. E. and Wallace, A. R.: 'Maximising energy capture from distributed generators in weak networks,' *IEE Proc. Gener. Transm. Distrib.*, 2004, 151 (5), pp. 611-618
- [22] Vovos, P. N., Kiprakis, A. E., Wallace, A. R. and Harrison, G. P.: 'Centralized and Distributed Voltage Control: Impact on Distributed Generation Penetration', *IEEE Trans. Pwr. Sys.*, 2007, 22 (1), pp. 476-483
- [23] Smith, M.: Personal communication (Scottish Hydro-Electric Power Distribution Ltd, Oct. 2007)
- [24] Ochoa, L. F., Dent, C. J. and Harrison, G. P.: 'Maximisation of intermittent distributed generation in active networks', *CIREN Seminar 2008: SmartGrids for Distribution*, June 2008, Frankfurt, Germany
- [25] Currie, R. A. F., Ault, G. W., Fordyce, R. W., MacLeman, D. F., Smith, M. and McDonald, J. R.: 'Actively Managing Wind Farm Power Output,' *IEEE Trans. Pwr. Sys.*, 2008, 23 (3), pp. 1523-1524
- [26] Cobelo, I., Shafiu, A., Jenkins, N., Strbac, G.: 'State estimation of networks with distributed generation', *European Transactions on Electrical Power*, 2006, 17 (1), pp. 21-36

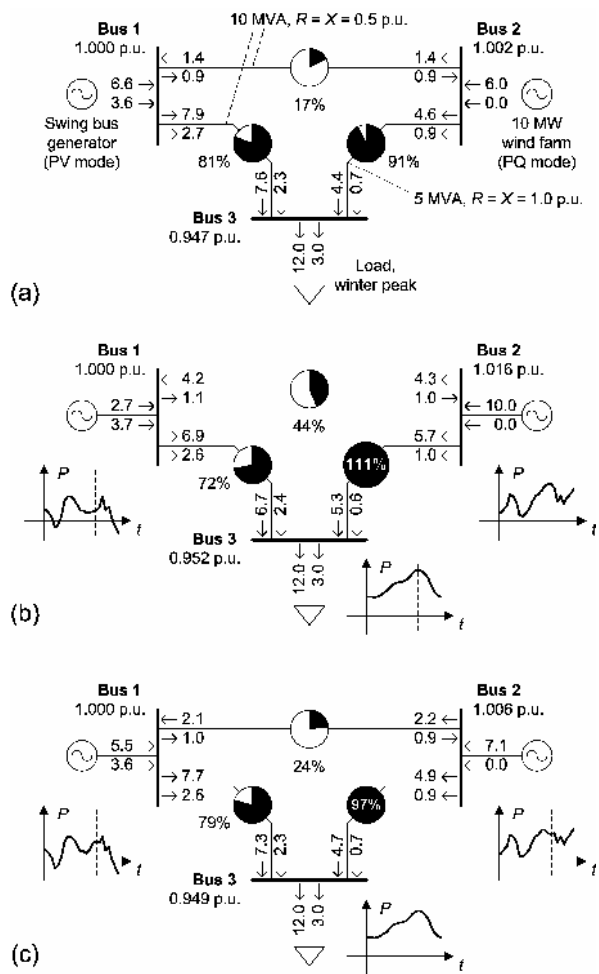

Fig. 1. Power flow solutions for a three bus bar network: (a) snapshot AC power flow; (b) time series AC power flows; (c) time series AC optimal power flows. Numbers above or to the left of a branches indicate active power in MW numbers below the branch or to the right indicate reactive power in MVAR.

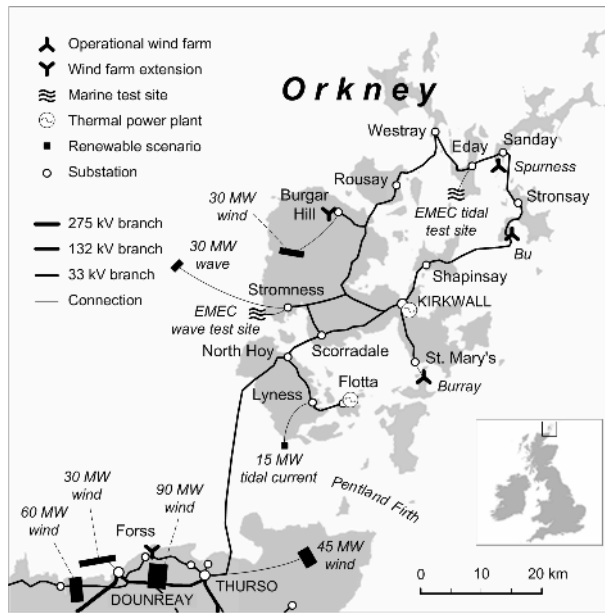

Fig. 2. Electricity network and existing and modelled generators in the Orkney area.

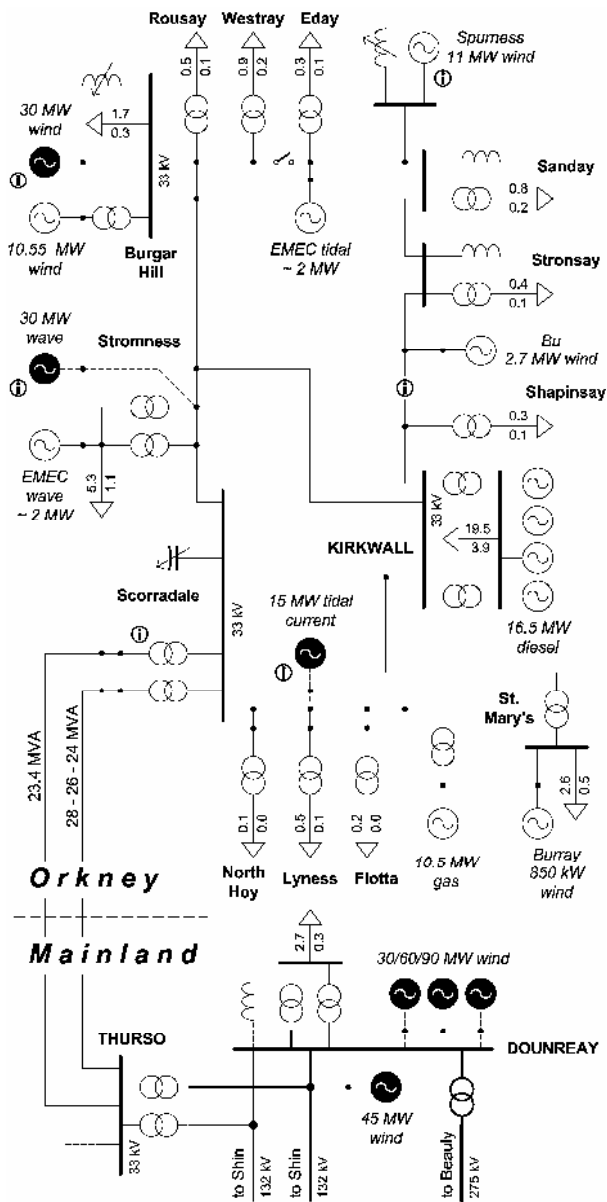

Fig. 3. Network model of the Orkney area. Numbers above or to the left of a branch indicate active power in MW; numbers below the branch or to its right indicate reactive power in MVar. Data for components marked with 'Ⓢ' are presented in the diagrams below.

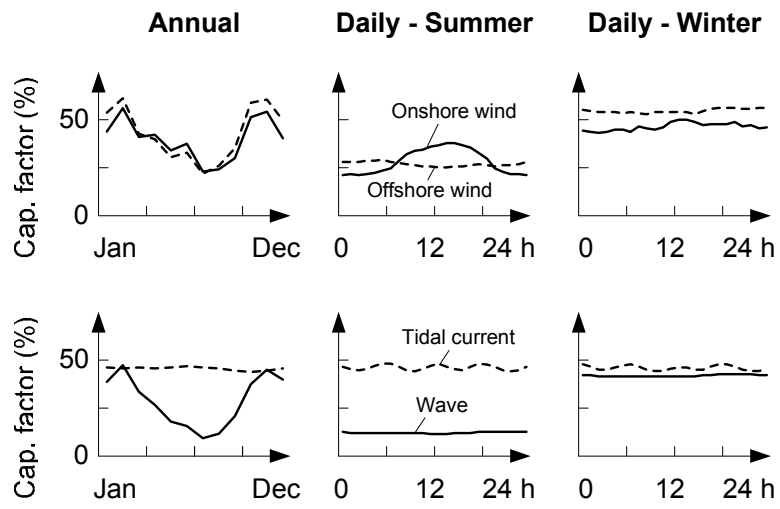

Fig.4. Annual and daily renewable generator output profiles for Orkney, based on 2001-2003 hourly data for wind (top) and marine energy (bottom) [10].

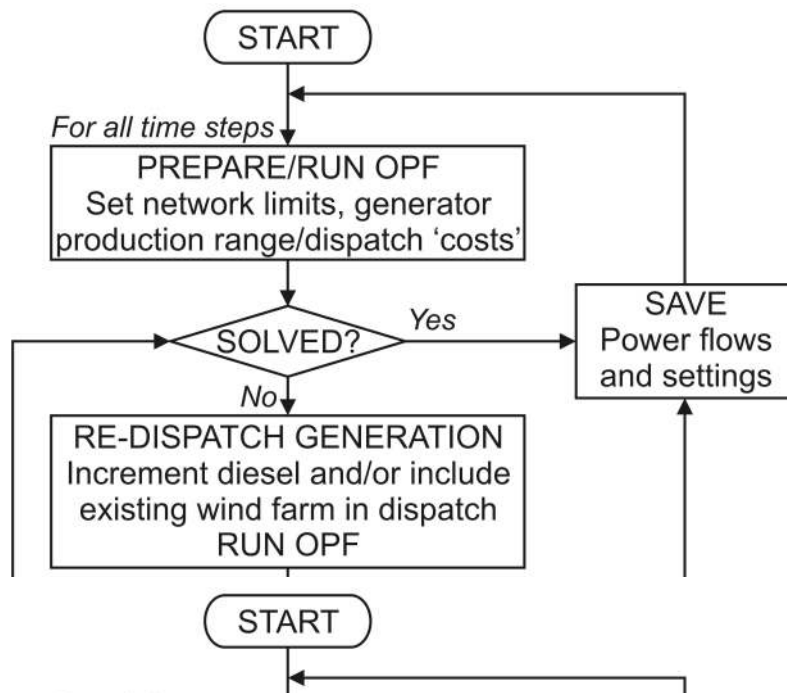

Fig. 5. Flow chart of process to determine optimal dispatch of renewable generation across the time series.

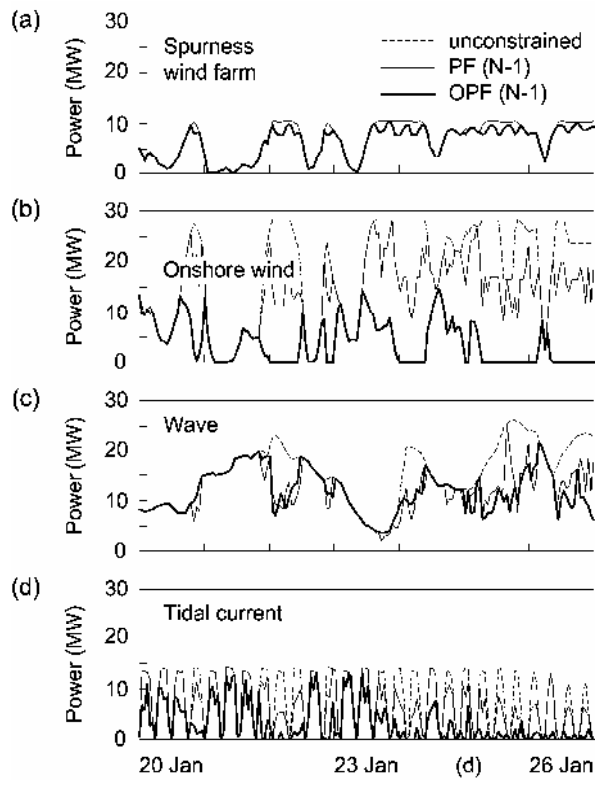

Fig. 6. Time series of renewable output on Orkney during a week in January 2003: (a) 11 MW Spurness wind; (b) new 30 MW onshore wind farm; (c) new 30 MW wave farm; (d) new 15 MW tidal current farm.

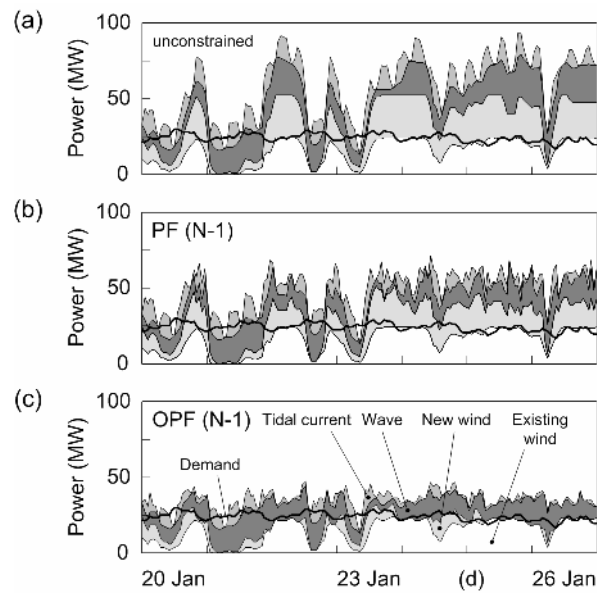

Fig. 7. Stacked renewable generation curves and demand on Orkney for a week in January 2003: (a) Unconstrained output of all generators; (b) Output constrained to ensure power flow convergence; (c) Output constrained by OPF.

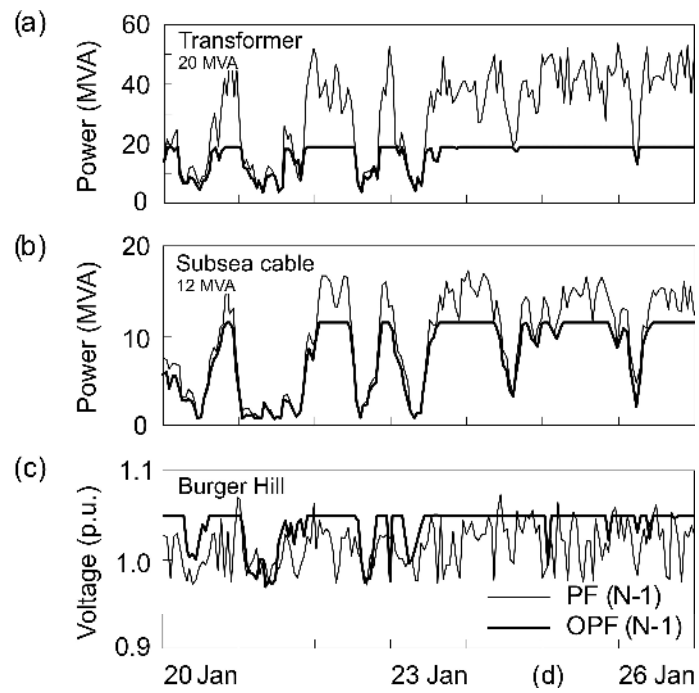

Fig. 8. Sample component loading and bus voltages on Orkney for a week in January 2003: (a) Power flow through Scorradale voltage regulator; (b) Power flow through Subsea cable between Bu wind farm and Shapinsay; (c) Bus voltage at Burger Hill.

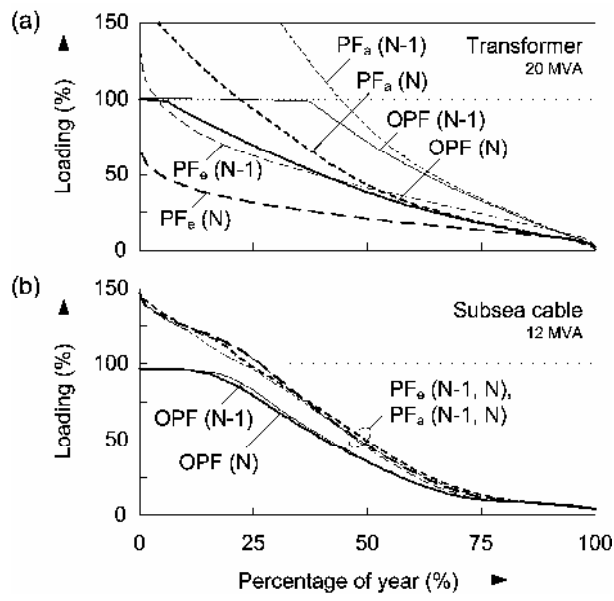

Fig. 9. Component loading for different scenarios and solution methods: (a) Scorradale voltage regulator; (b) Subsea cable between Bu wind farm and Shapinsay.

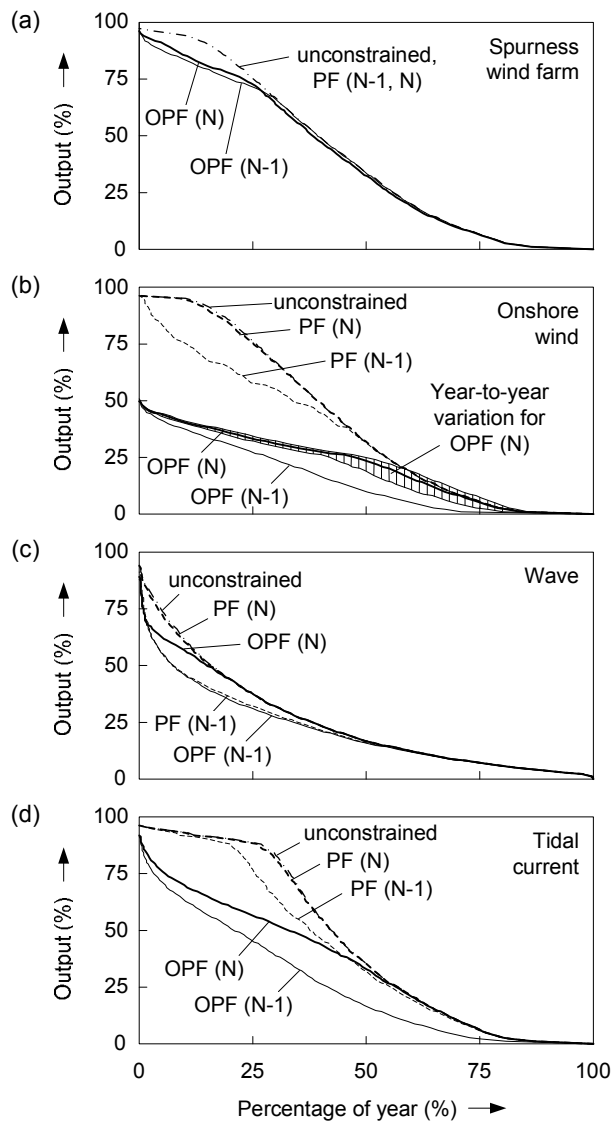

Fig. 10. Renewable project output exceedance curves for Orkney, 2001-2003. (a) 11 MW Spurness wind farm (b) new 30 MW onshore wind farm; (c) new 30 MW wave farm; (d) new 15 MW tidal current farm.