

# Assessment of metal contamination and retention capacity of highway embankment soils

vorgelegt von:  
Dipl.-Ing.  
Moritz Werkenthin  
geb. in Berlin

von der Fakultät VI - Planen Bauen Umwelt  
der Technischen Universität Berlin  
zur Erlangung des akademischen Grades

Doktor der Ingenieurwissenschaften  
- Dr.-Ing. -

genehmigte Dissertation

Promotionsausschuss:  
Vorsitzender: Prof. Dr. Martin Kaupenjohann  
Gutachter: Prof. Dr. Gerd Wessolek  
Gutachterin: PD Dr. Patricia Göbel

Tag der wissenschaftlichen Aussprache: 08. April 2015

Berlin 2015







## Abstract

The decentralised infiltration of highway runoff into the adjacent embankment is a common stormwater management practice that sustainably changes the quality of the soils and soil solution. Accumulation, retardation and migration of metals plays an important role in terms of soil and groundwater protection. In the past, embankments were usually made of topsoil material from the surrounding area. However recent changes in road construction regulations require the application of accurately defined gravel-soil mixtures in order to ensure drivability in emergency cases. The objective of my doctorate thesis was to assess the metal retention capability of existing and newly constructed stable highway embankments from infiltrating road runoff in order to highlight the risk of groundwater contamination and deduce possible improvements for future embankment constructions.

In a first step a literature review was conducted to determine the metal (Cd, Cr, Cu, Ni, Pb and Zn) pollution in embankment soils and soil solutions of different study sites across the European highway network. In a second step the metal retention capability of an existing embankment at the A115 highway was investigated using both field and laboratory experiments. In a third step three lysimeters were filled with different embankment materials and installed along the A115 highway in order to assess metal retention capacity of newly constructed stable embankments from diffuse runoff infiltration.

The European data synthesis showed that metal concentrations are strongly increased in the topsoil layer (0–<5 cm) of the first 5 m beside the road, which is the area receiving the majority of infiltrating road runoff. The mean concentrations in this area were 0.7 (Cd), 28 (Cr), 48 (Cu), 25 (Ni), 106 (Pb) and 179 (Zn) mg kg<sup>-1</sup>. Typically soil contamination decreased with increasing soil depth or distance from the road. The concentration patterns of metals in soil solution were independent from concentrations in the soil matrix. Solute concentrations often increase within a distance up to 10 m which is probably due to a lower soil pH and low percolation rates at this distance.

Metal concentrations in the existing embankment soil at the A115 were strongly increased after long-term operation. They were up to thirty times higher (Cd and Cu) compared to a reference site at 800 m distance to the highway. Dissolved metal concentrations in soil solution were often higher than in the road runoff, indicating that leaching from soil matrix was largely responsible for the elevated metal levels. However, adsorption experiments showed that the metal retardation capacity of the old embankment soil is 10 to 20 times higher compared to reference soil without influence of traffic. The increasing metal retention capacity was caused by the higher soil pH and the higher clay and C<sub>org</sub> content of the embankment soil, most likely resulting from highway traffic induced particle and sediment input.

At the lysimeter study site, metals from road runoff were largely associated with particles and sediments (78-98%). Along with the highway runoff, considerable loads of sediments ( $4.7 \text{ kg m}^{-2} \text{ a}^{-1}$ ). The mean metal concentrations in road runoff were 0.6 (Cd), 58 (Cr), 166 (Cu), 21 (Ni), 29 (Pb) and 527 (Zn)  $\mu\text{g L}^{-1}$ . The high infiltration rates lead to increased groundwater recharge which are increased up to 22 times ( $4100 \text{ mm a}^{-1}$ ) compared to natural conditions. Dissolved metal concentrations in soil solution of stable highway embankments were not significantly higher compared to the non-stable reference. Total metal concentrations in soil solution were, depending on the metal, more than twice as high as dissolved concentrations ranging from 0.4-0.7 (Cd), 14-20 (Cr), 28-114 (Cu), 11-25 (Ni), 16-42 (Pb) and 67-97 (Zn)  $\mu\text{g L}^{-1}$ . The ratio of particle-bound metals was significantly higher than in the existing embankment, which could be a result of the relatively short operating time.

Overall the metal retention capability of existing highway embankments from infiltrating road runoff is adequate from the legislators' point of view. At existing, highly polluted embankment sites, leaching from soil matrix can sporadically lead to problematic metal concentrations in soil solution. The infiltration of runoff in newly constructed, stable embankments do not increase the risk of groundwater contamination with respect to the current trigger values. However, high infiltration rates directly beside the road facilitate the transfer of high metal loads into deeper soil layers and potentially into the groundwater as well. To reduce metal loads in the area of the embankments, it is recommended to specify a minimum share of fine soil ( $<0.063 \text{ mm}$ ) for embankment materials. Based on the present findings, future research should address the change of metal retention capacity from newly constructed embankment over time.

## Zusammenfassung

Die Entwässerung von Autobahnen erfolgt in Deutschland häufig über das angrenzende Bankett, was zu einem erheblichen Schwermetalleintrag in den Straßenrandbereich führt. Aus Sicht des Grundwasserschutzes müssen Straßenbankette daher über ein ausreichendes Schwermetallretentionsvermögen verfügen. Bankette bestehen in der Regel aus dem in der Umgebung anstehenden Oberboden. Neu angelegte Bankette müssen dagegen aufgrund geänderter rechtlicher Vorgaben aus einer definierten Boden-Schotter-Mischung konstruiert werden, um das Befahren im Notfall zu ermöglichen. In dieser Arbeit habe ich das Schwermetallrückhaltevermögen bestehender und neu angelegter, standfester Bankette untersucht, um eine potentielle Gefährdung des Grundwassers durch die Infiltration des Straßenabflusses abzuschätzen.

Um die Schwermetallbelastung (Cd, Cr, Cu, Ni, Pb und Zn) von Banketten/ Straßenrandböden verschiedener Standorte in Europa zu bestimmen, wurde eine umfassende Literaturstudie durchgeführt. Das Schwermetallrückhaltevermögen eines langjährig bestehenden Autobahnbankettes an der A115 wurde anhand verschiedener Labor- und Feldversuchen ermittelt. An einem anderen Abschnitt der A115 wurde eine Lysimeterstation mit drei unterschiedlichen Bankettvarianten errichtet, um das Schwermetallrückhaltevermögen neu gebauter, standfester Bankette zu untersuchen.

Die Literaturstudie ergab, dass die Schwermetallkonzentrationen in der obersten Bodenschicht (0–<5 cm) in den ersten 5 m neben der Straße an allen Standorten stark erhöht sind, im Mittel lagen sie bei 0.7 (Cd), 28 (Cr), 48 (Cu), 25 (Ni), 106 (Pb) und 179 (Zn) mg kg<sup>-1</sup>. Dies ist der Bereich in dem der Straßenabfluss primär infiltriert. Die Schwermetallkonzentrationen der Bodenmatrix nahmen in der Regel mit zunehmender Tiefe und Entfernung zur Straße ab. Die Studie zeigte weiterhin, dass die Konzentrationen in der Bodenlösung nicht zwangsläufig diesem Muster entsprechen. Die Lösungskonzentrationen in 10 m Entfernung zur Straße waren oftmals höher als am unmittelbare Straßenrand, was auf die geringeren Boden pH-Werte und Sickerwasserraten in dieser Entfernung zurückzuführen ist.

Im bestehenden Bankett der A115 waren die Schwermetallkonzentrationen um bis zu 30-mal höher (Cd und Cu) als die Konzentrationen des Referenzbodens in ca. 800 m Entfernung zur Straße. Die Lösungskonzentrationen im Sickerwasser waren ebenfalls erhöht, sie lagen zum Teil über den Konzentrationen des Straßenabflusses. In Laborversuchen konnte gezeigt werden, dass das Schwermetallretentionsvermögen des bestehenden Banketts 10 bis 20 Mal höher war als das des Referenzbodens. Der Eintrag von Sedimenten und Partikeln führte zu einem Anstieg des pH-Wertes und des C<sub>org</sub> Gehaltes im Bankett und somit auch zu einer Erhöhung der Sorptionsfähigkeit.

Die Messungen an der Lysimeterstation haben gezeigt, dass die Schwermetalle im Straßenabfluss größtenteils an Partikel bzw. Sedimente gebunden (78-98%) sind. Zusammen mit dem Straßenablauf wurden große Mengen an Sedimenten ( $4,7 \text{ kg m}^{-2} \text{ a}^{-1}$ ) in das Bankett eingetragen. Im Mittel lagen die Konzentrationen bei 0,6 (Cd), 58 (Cr), 166 (Cu), 21 (Ni), 29 (Pb) und 527 (Zn)  $\mu\text{g L}^{-1}$ . Durch die hohen Infiltrationsraten direkt an der Straße war die Grundwasserneubildungsrate im Bereich des Bankettes um bis 22-mal höher ( $4100 \text{ mm a}^{-1}$ ) als unter natürlichen Bedingungen. Die Lösungskonzentrationen im Sickerwasser der beiden standfesten Varianten waren nicht signifikant höher als die der nicht standfesten Referenz. Die Gesamtkonzentrationen in der Bodenlösung waren, je nach Element, mehr als doppelt so hoch wie die Lösungskonzentrationen und lagen zwischen 0,4-0,7 (Cd), 14-20 (Cr), 28-114 (Cu), 11-25 (Ni), 16-42 (Pb) und 67-97 (Zn)  $\mu\text{g L}^{-1}$ . Der Anteil partikulär gebundener Schwermetalle an der Gesamtkonzentration war in den neu gebauten Banketten deutlich höher als in dem bestehenden Bankett. Dies ist vermutlich auf die relativ kurze Standzeit der Bankettlysimeter zurückzuführen ist.

Das Schwermetallrückhaltevermögen von bestehenden Banketten genügt in der Regel den geltenden rechtlichen Ansprüchen in Bezug auf den Grundwasserschutz. An langjährig betriebenen Autobahnstandorten kann es aber aufgrund von Schwermetalldesorption vereinzelt zu problematischen Lösungskonzentrationen im Bankett kommen. Die Versickerung von Straßenabfluss in standfeste Bankette führt, in Bezug auf die aktuellen Prüfwerte, nicht zu einer erhöhten Grundwassergefährdung. Die hohen Infiltrationsraten im Bereich des Bankettes führen, trotz relativ niedrigen Sickerwasserkonzentrationen, zu einer Verlagerung erheblicher Schwermetallfrachten in tiefere Bodenschichten und damit möglicherweise auch ins Grundwasser. Um die Schwermetallfrachten im Bankettbereich möglichst gering zu halten sollte einen Mindestfeinkornanteil ( $<0,063 \text{ mm}$ ) für Bankettmaterialien festgelegt werden. Zukünftige Forschungsvorhaben in diesem Bereich sollten untersuchen inwieweit sich das Schwermetallretentionsvermögens neu gebauter, standfester Bankette im Laufe der Betriebszeit verändert.



## Acknowledgments

I would like to use this opportunity to express my gratitude to everyone who supported, encouraged and assisted me throughout the course of my work. Special thanks go to:

Prof. Gerd Wessolek for supervising the thesis, his confidence in my work and the constructive discussions on my findings;

PD Dr. Patricia Göbel for co-examining and reviewing this thesis;

Dr. Björn Kluge my mentor for his support and inspiration throughout the entire work. Without his motivate nature, his help after major setbacks and the countless hours of discussion and working together, this dissertation would not have been possible;

the staff members of the Department of Soil Conservation, for valuable advice and discussions, their companionship and their support whenever it was necessary, especially Steffen Trinks, Michael Facklam, Stefan Abel and Jessica Strenzel;

Marie Hölscher for being a patient roommate whenever a spontaneous discussion in our office took much longer than expected;

the laboratory staff members of the Department of Soil Science for their support, especially Iris Pieper for her reliable and uncomplicated help with sample analysis;

the research-accompanying group of the Federal Highway Research Institute for constructive proposals and thoughtful feedback, especially Dr. Maik Schüßler for his support with the local authorities and during study site construction;

Adrian Doonan for his willingness to read all parts of this thesis in order to provide linguistic assistance;

my family for the support they provided me through my entire life. Only the certainty of their absolute support in any difficult situation allowed me to reach this goal;

Anne Fastabend for sharing her live with me, for always being patient, encouraging, understanding and for enduring all my moods and quirks, which drastically increased during the final stage of this dissertation;

my friends who have always been there whenever I needed a timeout from scientific work and discussions;

the German Federal Highway Research Institute (BAST) for financial support.

**Table of contents**

<b>Abstract</b> .....	<b>I</b>
<b>Zusammenfassung</b> .....	<b>III</b>
<b>Acknowledgments</b> .....	<b>V</b>
<b>Table of contents</b> .....	<b>VI</b>
<b>1. General introduction</b> .....	<b>2</b>
1.1. Context.....	2
1.2. Sources, distribution and concentrations of traffic derived contaminants .....	3
1.3. Contamination of roadside soils .....	6
1.3.1. Metal transport in roadside soils .....	7
1.3.2. Potential groundwater degradation .....	8
1.4. Regulatory framework .....	9
1.4.1. Highway runoff management.....	9
1.4.2. Construction requirements of embankment soils.....	11
1.5. Research objectives.....	12
1.6. Methods.....	14
1.6.1. Literature review .....	14
1.6.2. Field and laboratory investigations.....	15
1.6.3. Lysimeter studies.....	16
<b>2. Metals in European roadside soils and soil solution – A review</b> .....	<b>20</b>
2.1. Introduction.....	21
2.1.1. Sources of Pollution.....	21
2.1.2. Pathways of pollutant transport .....	22
2.1.3. Roadside soils .....	23
2.1.4. Metal mobility in roadside soils.....	25
2.1.5. Soil solution.....	26
2.1.6. Objectives.....	26
2.2. Methods.....	27
2.2.1. References and characteristics of monitoring sites .....	27
2.2.2. Compilation and data synthesis .....	29
2.3. Results.....	30
2.3.1. Metals in roadside soils.....	30
2.3.2. Metals in soil solution.....	40
2.4. Conclusion .....	45

<b>3.</b>	<b>Metal leaching in a highway embankment on field and laboratory scale.....</b>	<b>48</b>
3.1.	Introduction .....	49
3.2.	Material and methods .....	51
3.2.1.	Study site .....	51
3.2.2.	Sampling in field .....	52
3.2.3.	Laboratory leaching experiments .....	53
3.3.	Results and discussion .....	56
3.3.1.	Soil properties .....	56
3.3.2.	Road runoff .....	57
3.3.3.	Soil metal concentrations .....	59
3.3.4.	Soil solution metal concentrations .....	62
3.3.5.	Adsorption experiments .....	63
3.3.6.	Soil solution concentrations-comparison of laboratory and field data .....	65
3.4.	Conclusions .....	66
<b>4.</b>	<b>Assessment of metal retention in newly constructed highway embankments.....</b>	<b>68</b>
4.1.	Introduction .....	69
4.2.	Material and methods .....	70
4.2.1.	Study site .....	70
4.2.2.	Lysimeter construction.....	71
4.2.3.	Laboratory analysis.....	72
4.3.	Results and discussion .....	73
4.3.1.	Properties of the embankment soils.....	73
4.3.2.	Runoff volume and infiltration rates.....	73
4.3.3.	Metals in road runoff .....	75
4.3.4.	Metals in soil solution .....	77
4.4.	Conclusions .....	82
<b>5.</b>	<b>Synthesis .....</b>	<b>86</b>
5.1.	Metals in roadside soils.....	86
5.2.	Soil solution .....	87
5.3.	Metal loads.....	89
5.4.	Overall conclusions .....	89
5.5.	Challenges and recommendations for future embankment construction practice.....	90
5.6.	Future research questions .....	92
<b>6.</b>	<b>References .....</b>	<b>94</b>
	<b>List of figures .....</b>	<b>VIII</b>
	<b>List of tables .....</b>	<b>XI</b>
	<b>Appendix - supplementary material .....</b>	<b>XII</b>



# Part I: Introduction

## 1. General introduction

### 1.1. Context

The management of highway runoff is an important issue in terms of soil and groundwater protection. Due to the construction of highways and roads in general, previously permeable surfaces are sealed leading to a high volume of surface runoff water after rain events. The decentralised infiltration of highway runoff into the adjacent embankment is one important technique in stormwater management practice, especially for rural areas (Piguet et al., 2008; Ingvertsen et al., 2012). Compared to rainwater, highway runoff contains elevated concentrations of potential contaminants such as metals, salts, polycyclic aromatic hydrocarbons and nutrients (Göbel et al., 2007; Kayhanian et al., 2012).

The contaminants arise from a variety of sources such as exhaust from fuel combustion, tire wear, road maintenance, vehicle component leaching and road abrasion (Lindgren, 1996; Folkesson et al., 2009). Infiltration into the embankment soils thus leads to a sustainable change in soil and soil solution quality. Besides runoff water, dust deposition and spray water are relevant transport mechanisms in terms of the diffuse distribution of contaminants in roadside environments (Legret and Pagotto, 2006; Steiner et al., 2007; Thorpe and Harrison, 2008)

Embankment soils are usually characterized by anthropogenic activity. During highway construction, the surrounding and underlying soils are often rearranged, compacted and mixed with (anthropogenic) material from other sites (Wessolek et al., 2011). In Germany, the embankment, slope and ditch (if present) are technically a part of the highway structure and thus are also built during road construction. They constitute the interface between the highway structure and the surrounding environment.

Therefore, the embankment soils must fulfil requirements from different legal areas. Regulations related to the safety of the road, especially concerning the stability of the highway structure and drivability of the embankment soils in emergency cases, have to be applied. Furthermore, a fast and reliable dewatering of the driveway must be ensured in order to prevent aquaplaning after heavy rainfall events (RAS-Ew, 2005; ZtVE-StB, 2009). On the other hand environmental regulations related to the soil and water protection must be considered (BBodSchG, 1998; BBodSchV, 1999; WHG, 2002). The general aim of these regulations is to prevent the negative change of soil and water properties resulting from the transfer of traffic-induced pollutants into the roadside environment.

Road adjacent soils usually have elevated contents of road traffic induced contaminants compared to background concentrations (Harrison et al., 1985; Zehetner et al., 2009; Kluge and Wessolek, 2012). Metals are contaminants of major interest because of their persistent and bio-accumulative nature. Although certain metals such as Zn and Cu are essential micronutrients for plants, animals and humans, most can be toxic at a certain level of exposure. Among others, the most widely recognized and examined metals in roadside soils are Cd, Cr, Cu, Pb, Ni and Zn (Goyer and Clarkson, 1996; Folkeson et al., 2009). The diffuse infiltration of road runoff increases the amount of metals introduced into the embankment soils. Physical and chemical retention of traffic induced metal emissions in the embankment soils increases the soil matrix concentrations. The pollutant retardation largely depends on the filter properties of the soils. Due to changing environmental conditions, retained metals may be mobilized again moving into deeper soil layers (Bäckström et al., 2004; Kocher et al., 2005; Blecken et al., 2009). The accumulation, retardation and migration of metals in embankments therefore plays a significant role in terms of soil and groundwater protection.

## 1.2. Sources, distribution and concentrations of traffic derived contaminants

Road construction, traffic and maintenance influence the surrounding environment in many different ways. Among other ecological impacts, a wide range of pollutants is transferred to the adjacent areas (Trombulak and Frissell, 2000). The pollutants released by road traffic activity originate from a variety of different sources (Fig. 1.1) including the following five groups: traffic & cargo, pavement & embankment material, road equipment, maintenance & operation and external sources (Folkeson et al., 2009).

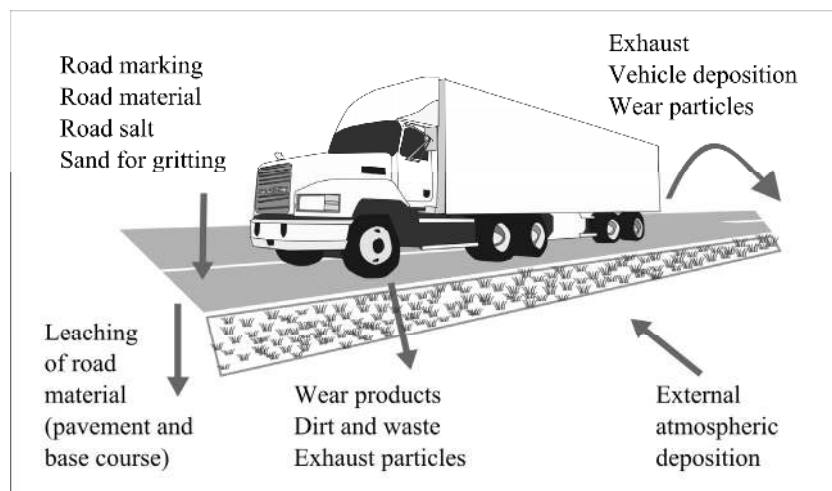

Fig. 1.1: Sources of contaminants in the roadside environment, derived from Folkeson et al. (2009).

Different studies on emission rates of single processes like tire wear, fuel combustion and pavement leaching have been conducted to quantify their specific emission rates (e.g. Lindgren, 1996; Thorpe and Harrison, 2008; McKenzie et al., 2009). The amount and distribution of pollutants emitted depends on different factors such as traffic intensity, volume of light and heavy traffic, wind direction, road design, fuel used and driving behaviour. The pollutants released from road traffic are usually transferred into the roadside environment via road runoff, aerial transport and spray water. However, the majority of the pollutants stay close to the road, accumulating in the adjacent soil and vegetation (Folkeson et al., 2009). A more detailed description up to which distance pollutants are transported by the different ways of dispersion is provided in section 2.1.2.

Among the most investigated pollutants released by road traffic are nitrogen oxides, hydrocarbons, methane, sulphur dioxide, metals, carbon monoxide and organic pollutants (Wessolek et al., 2011). They can occur in gaseous, dissolved and particulate form, where a diameter of  $0.45 \mu\text{m}$  is often used to define the limit between dissolved and particulate matter. The emitted pollutant, similarly metal fraction, varies among dissolved and particle bound forms as well as between the different transport paths (Fig. 1.2).

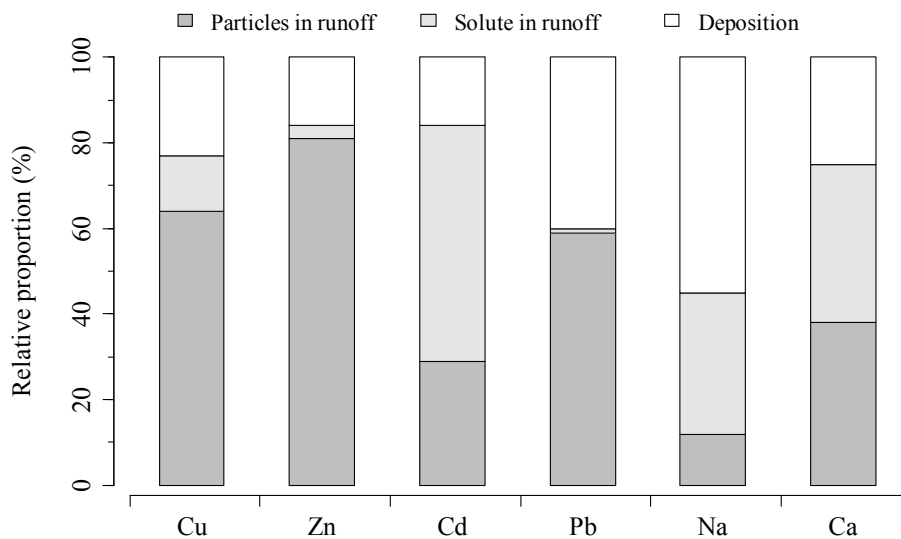

Fig. 1.2: Fractions of metals, Na and Ca of total depositions at a German highway site in 0-1 m distance from the road, adapted from Kocher and Wessolek (2002).

At one meter distance to the road, some metals (Pb and Zn) are almost entirely associated with particles, either in runoff or as dust deposition, whereas a relevant part of other elements (Cd, Na and Ca) also occur in a dissolved state. These differences are related to the diverse emission sources (tire wear, fuel combustion, etc.) and thus to the characteristics of the emitted pollutants. The nature or condition of the pollutants transferred into the surrounding environment is important in terms of mobility and retention in roadside soils (Kocher and Wessolek, 2002).



The quality of road runoff and street dust has been the subject of many investigations and is well documented in numerous publications e.g. Sternbeck et al. (2002), Harrison et al. (2003), Göbel et al. (2007) and Kayhanian et al. (2012). Highway runoff quality and quantity attract an especially high amount of attention since they affect different environmental departments and policy areas. Besides metals, electrical conductivity, pH value, total suspended solids, chemical and biological oxygen demand, total phosphorus and groups of organic pollutants are often identified parameters in road runoff. The change of the local water balance due to road drainage is also a subject of investigation.

In order to provide an overview of metal concentrations occurring, different authors collected and summarized data from research studies investigating runoff quality from highly trafficked roads (Tab. 1.1).

Tab. 1.1: Median metal concentrations in road runoff obtained from different investigations.

		Cd	Cr	Cu	Ni	Pb	Zn
		µg L <sup>-1</sup>					
Göbel et al. (2007); rainwater		0.7	3	11	2	9	80
Göbel et al. (2007); main roads		1.9	11	97	11	170	407
Göbel et al. (2007); motorways		3.7	13	65	27	224	345
Kayhanian et al. (2012);	min	0.06	5.5	9.4	5.5	5.6	130
	med	1.1	9.4	49	9	40	340
	max	17	140	350	20	1860	19100

Metal concentrations in road runoff from traffic areas are usually significantly increased compared to rainwater. The median concentrations of the two review studies are in the same order of magnitude for the listed elements, with the possible exception of Pb. This deviation is probably due to the fact that the literature data of Göbel et al. (2007) were mostly determined before 1988. Kayhanian et al. (2012) could show that Pb concentrations in road runoff decreased exponentially from the 1980s to the new millennium in Europe and North America, which is credited to the Pb phase-out regulations.

Even though the values above represent median concentrations derived from long-term studies, minimum and maximum metal concentrations can vary greatly from site to site. This is due to a range of factors, such as: the amount of emitted pollutants, rain intensity, amount of precipitation, previous dry periods and the sampling strategy. There is also a substantial difference between the so-called event mean concentration and the first flush concentrations. The latter is a phenomenon in which a higher pollutant concentration occurs in the first portion of the runoff water, which is caused by an accumulation on road surfaces during dry periods (Kayhanian et al., 2012). All these circumstances illustrate the difficulty in implementing a universal treatment measure for contaminated road runoff.

### 1.3. Contamination of roadside soils

The permanent diffuse pollutant input from road traffic leads to elevated concentrations in the surrounding soils compared to background levels. Metal concentrations are usually highest in the top soil layer and decrease with increasing distance to the road as well as soil depth (Turer et al., 2001; Carrero et al., 2013; Modrzewska and Wyszowski, 2014). The distance related concentration decrease is mainly associated with the different ways of pollutant distribution. Metals transported via surface road runoff and splashing water can be carried up to 5 m and 10 m respectively, airborne distribution can extend up to 250 m (Kocher and Wessolek, 2002; Zechmeister et al. 2005). The vertical concentration decrease is correlated to the physical and chemical retardation in the topsoil horizon. The elevated amount of organic matter and the increased pH value of the road adjacent soil results in a high retention capacity and therefore also in high soil matrix concentrations (Turer and Maynard, 2003; Grigalaviciene et al., 2005; Boivin et al., 2008; Hjortenkrans et al., 2008). Concentrations in soil matrix can also vary strongly on a small scale even at the same distance or depth (Fig 1.3). This is partly related to traffic devices installed by the roadside soils. The leaching of crash barriers and road signs for example can lead to a release of metals, resulting in locally high lateral concentration gradients (Kluge and Wessolek, 2012).

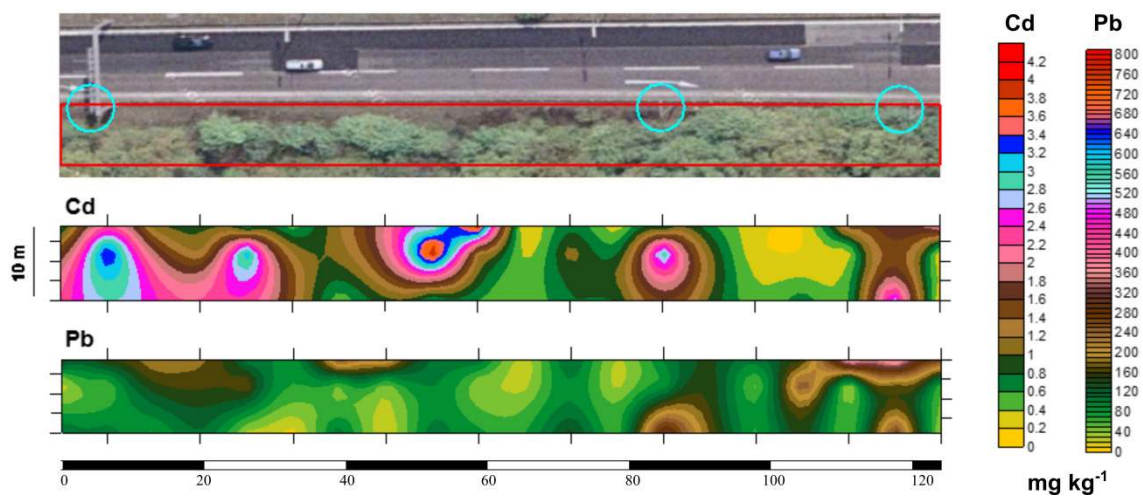

Fig. 1.3: Lateral pattern Cd and Pb distribution in the top 10 cm along the A115 highway near Berlin, adapted from Kluge and Wessolek (2012).

One important reason for small-scale variation of vertical metal distribution is the preferential flow phenomena. Preferential flow is a non-uniform movement of water and other compounds in soils that takes place only in a small portion of the pore system bypassing a portion of the soil matrix.

In field studies performed in a roadside soil near Madrid, Garrido and Helmhart (2011) it was demonstrated that Pb concentrations in the preferential flow domains are higher than in the surrounding soil matrix (Fig 1.4).

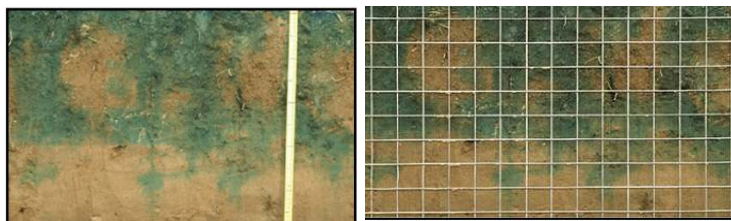

Fig. 1.4: Dye distribution in a roadside soil profile illustrating the preferential flow paths, adapted from Garrido and Helmhart (2011).

Another important aspect is the input of significant amounts of sediments and particles. The mass of sediments deposited on the embankment soils can vary between 1-36 kg m<sup>-1</sup> a<sup>-1</sup>, depending on the surrounding vegetation and traffic density (Zanders, 2005). Due to this input, a new topsoil layer develops which lies over the original soil surface and differs in texture and organic content from the underlying embankment soils (Jensen et al. 2006). Jensen (2004) determined an accumulation rate of approximately 1–6 mm per year in a swale at a Danish highway site. In Germany it is common practice to remove this new topsoil layer (2-5 cm) from the embankment every 5-12 years in order to ensure safe road dewatering (Kocher et al. 2008). Further relevant factors for metal distribution in roadside soils are discussed in section 2.

### 1.3.1. Metal transport in roadside soils

In (roadside) soils and soil solution, metals occur in various forms; the so-called species. The metal distribution between the different species in soil depends on a wide range of factors. In general, solubility and similarly the mobility of metals in soil decreases with increasing soil pH, clay minerals and the organic content (Alloway, 2012). These factors influence the reaction properties of metals such as precipitation-dissolution, adsorption-desorption, exchange reactions and complexation and thus also the distribution of the various metal species between soil matrix and soil solution (Bruemmer et al. 1986). These, as well as other factors influencing metal specification and mobility in soils, have already been described in detail in standard textbooks (e.g. Horn et al, 2010; Alloway, 2012) and will not be discussed further in this thesis.

The physical retardation mechanisms of the soil matrix also play an important role in terms pollutant transport since the metals introduced to roadside soils are largely associated with particles (Boivin et al., 2008; Clark et al., 2010).

The principal contaminant transport mechanisms in (roadside) soils are diffusion, advection and dispersion. Even though the transport mechanisms are influenced by the same factors as in natural soils, their characteristics are quite different. The most significant difference is caused by the adjacent, sealed area resulting in; a disturbed water balance, soil compaction, the occurrence of technogenic materials in the soil matrix and the elevated input of nutrients and contaminants due to dust deposition and runoff infiltration (Wessolek et al., 2011). In the unsaturated embankment soils, metal transport strongly depends on the soil moisture distribution of the capillary pore system. The main fluxes of the vadose zone are induced by percolation and evaporation, resulting in vertical water movement. Since advection is the dominant transport mechanism for pollutants in roadside soils, water movement direction will control the contaminant flux (Folkesson et al., 2009). The direction of the mass transport will essentially be vertical, upwards or downwards to the deeper soil layers. Due to the special hydrological conditions of roadside soils (usually greatly increased infiltration rates), the contaminant transport is primarily directed downwards (Kocher and Wessolek, 2002).

### 1.3.2. Potential groundwater degradation

As an irreplaceable and essential resource the protection of groundwater against pollution is a major target in environmental policy. Due to the permanent input of pollutants, increased soil matrix concentrations and the elevated infiltration rates, roadside soils constitute a potential threat to the groundwater aquifer. Investigations on groundwater aquifer up and downstream of a highway site in Massachusetts, USA showed that metal concentrations were increased at the downstream well (Fig. 1.5).

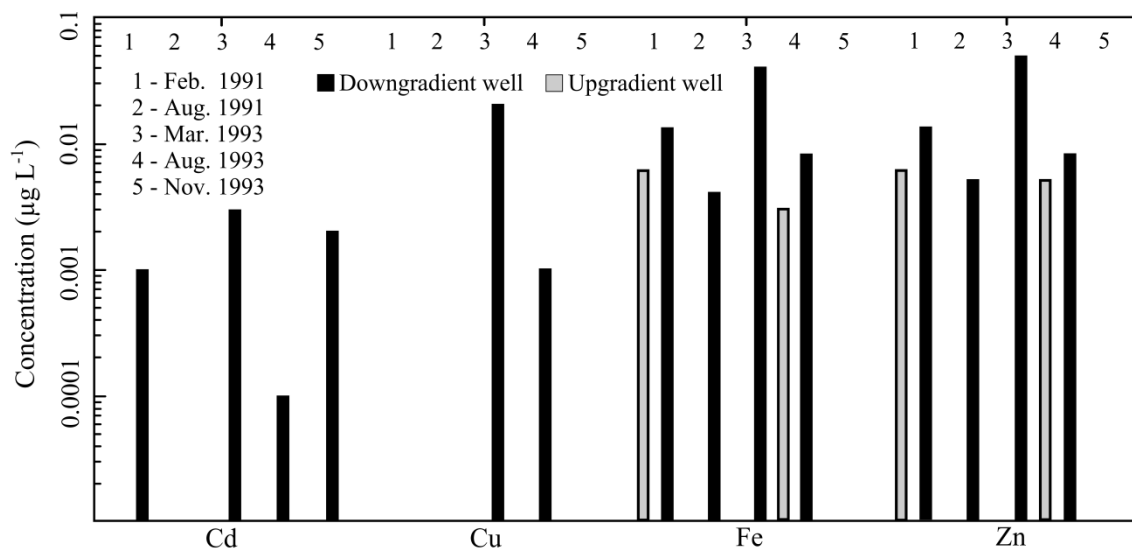

Fig. 1.5: Metal concentrations in groundwater measured upgradient and downgradient from a highway in Massachusetts, USA, adapted from Granato et al. (1995).

However, none of the concentrations measured at the study site exceeded national drinking water standards (Granato et al., 1995). Similar results were obtained at artificial runoff infiltration systems (Pitt et al., 1999; Weiss et al., 2008).

In Germany, the BBodSchV (1999) prescribes trigger values for the transfer of soil solution to the groundwater. Even though matrix concentrations in roadside soils are often significantly increased, metal concentrations in soil solution rarely exceed the prescribed trigger values. Even at highway sites with sandy soils, a low sorption capacity and a low pH, the risk for groundwater pollution is low (Kluge and Wessolek, 2012). Despite the fact the metal concentrations in soil solution rarely exceed the trigger values, the elevated infiltration rates directly beside the road can lead to remarkable metal loads (Kocher et al., 2005).

## **1.4. Regulatory framework**

### **1.4.1. Highway runoff management**

There are different ways of dealing with runoff water from paved roads and highways. In principle, the construction and operation of roads may not have a negative impact on the receiving ground and surface waters. At the European level, the European Water Framework Directive (Directive 2000/60/EC) requires water bodies to attain or keep a good ecological status. The water resource act (WHG, 2002) implements these requirements at the national level in Germany. This, in consequence leads to specific regulations for practice of the road dewatering. In order to ensure the proper treatment of road runoff, the directive for road construction – Part Dewatering (RAS-Ew, 2005) proposes standardized procedure for selecting the appropriate dewatering practice in Germany (Fig. 1.6). Additionally the directive for constructional measures of roads in water protection regions (RistWag, 2002) prescribes regulations for areas that need special protection.

In principle, the aim of the RAS-Ew (2005) is an extensive local infiltration of the runoff across the embankment, slope and ditch. In this way, contaminants from road runoff are supposed to be retained and degraded in the soil body. Furthermore, a groundwater recharge is achieved on-site directly where the precipitation occurs. If this is not possible because of geological, hydrological, ecological or engineering design reasons runoff water should be channelled and infiltrated at a proper location. In case infiltration is not possible at all, road runoff may be discharged into the surface water body. To minimize negative ecological and environmental impact, retention or treatment measures have to be implemented before discharging the collected runoff (Fig. 1.6). However, the RAS-Ew (2005) does not define a quantitative treatment goal for the road runoff.

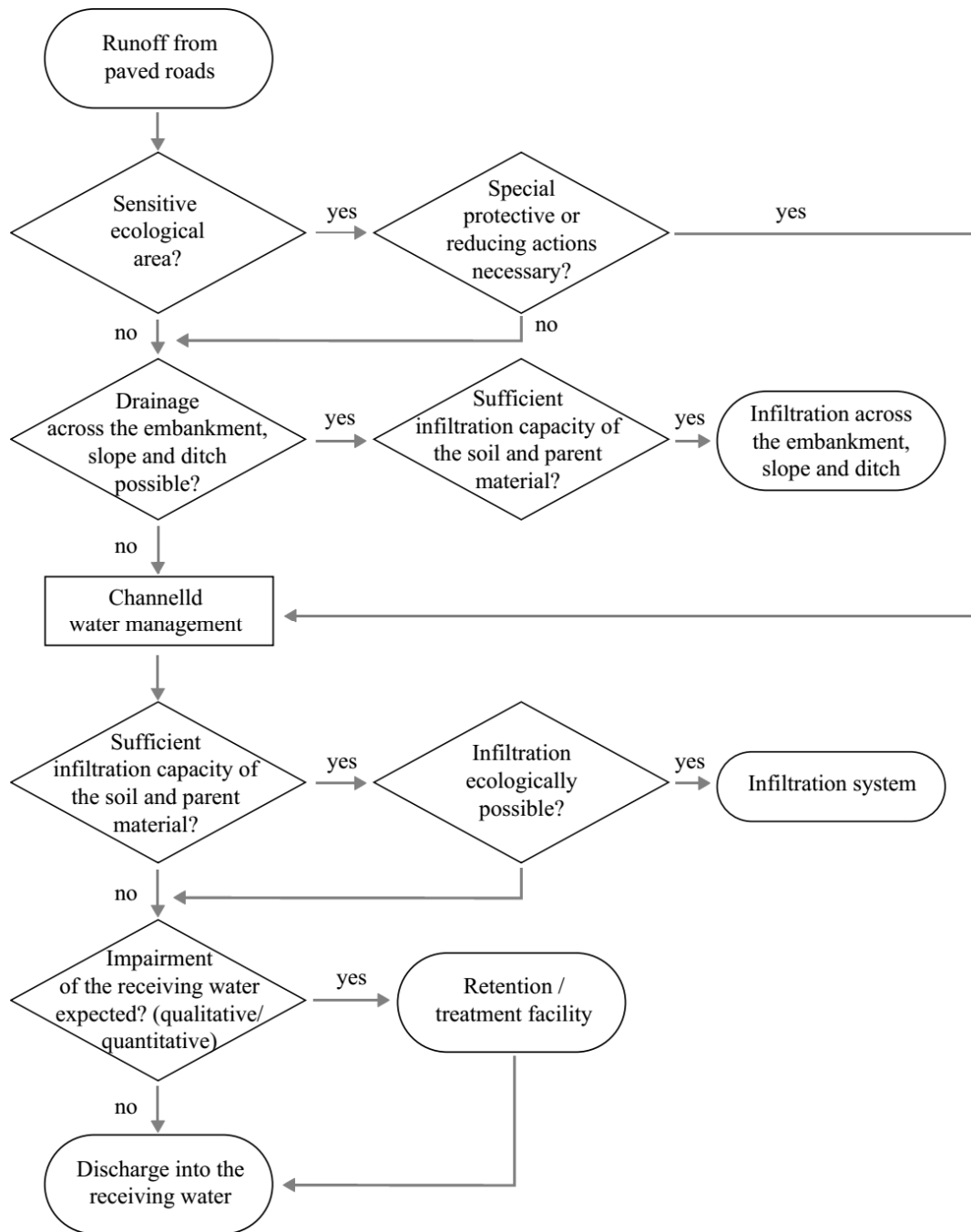

Fig. 1.6: Flowchart for the choice of the proper dewatering procedure (adapted from RAS-Ew, 2005).

The objective of an environmental road dewatering is the return of the possibly highest proportion of the road runoff to the natural water circle without degrading the existing water body. The measure favoured by the RAS-Ew (2005) counts on the ability of the soil to retain pollutants in order to protect the groundwater without reducing the local groundwater recharge rate significantly. On the one hand this serves to protect an irreplaceable resource – groundwater - yet on the other hand, the necessary trade-off is the accumulation of persistent contaminants due to the infiltration of road runoff into the soil.

Although the natural soil properties must be protected according to the German Soil Protection Law (BBodSchG, 1998 and BBodSchV, 1999) there are exceptions within the area of roadside soils. Embankment slope and ditch technically belong to the road structure and therefore application of the BBodSchV (1999) is limited. Furthermore, with regards to the principle of proportionality, the unavoidable release and introduction of pollutants stemming from road traffic must be accepted.

#### 1.4.2. Construction requirements of embankment soils

As previously stated, roadside soils, namely embankment, slope and ditch, technically belong to the road structure. They serve primarily to bolster the stability of the road construction and safe road operation. Therefore, the technical conditions of contracts and guidelines for earthworks in road construction (ZtVE-StB, 2009) contain, in addition to regulations concerning the roadway construction, technical specifications for the embankment and slope as well (Fig. 1.7).

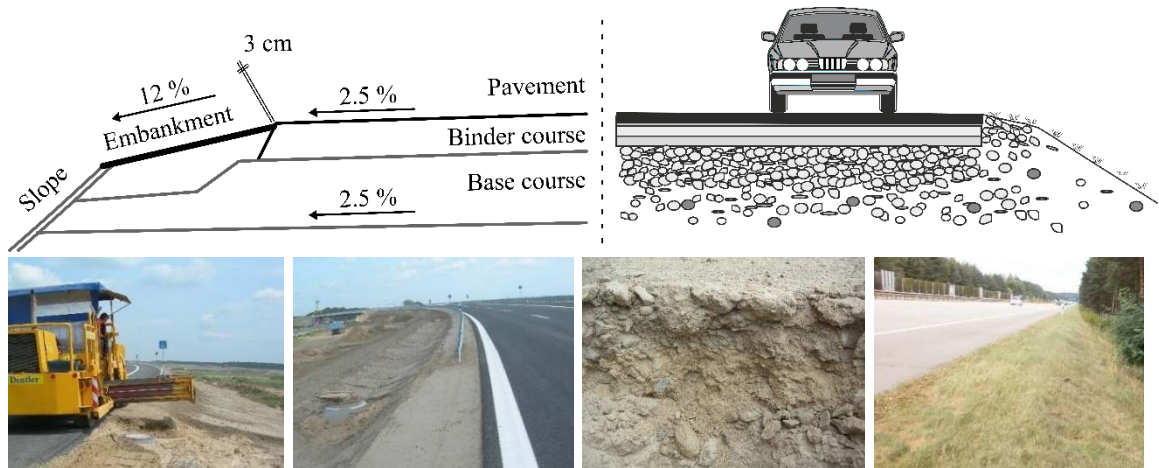

Fig 1.7: Top: Schematic sketch/ profile of a road construction suitable for dewatering across the embankment and slope derived from the RAS-Ew (2005). Bottom: Pictures of an embankment during compaction (left), an embankment right after construction (second from the right) with a channelled runoff collection system, an installed and compacted stable embankment soil (second from the right) and an existing greened embankment and slope suitable for diffuse infiltration (right).

For stable embankment constructions, only soils or mixed building materials containing a maximum grain size of 32 mm are applicable. Furthermore, a grain size fraction curve is defined to guarantee drivability in emergency cases (ZtVE-StB, 2009). Existing embankments however, are mostly composed of the local topsoil that accrues during road construction.

Characteristically, roadside soils are compacted due to the building activities and for conservation reasons. Stable embankment constructions even have to achieve a degree of 100% proctor density. In order to establish a grass vegetation, a thin layer of topsoil (5 cm) should be installed upon the compacted layer (ZtVE-StB, 2009).

The embankment and slope also have to guarantee a safe and proper road dewatering. They are therefore constructed at a specific inclination angle facilitating quick water drainage (Fig. 1.7). The inclination of the slope may be steeper than 66 % if stability can be assured and there is no risk of erosion. In order to protect the groundwater and effectively retain pollutants, the embankment also ought to have a low water permeability (RAS-Ew, 2005). In areas where a safe road drainage across the embankment is not possible (e.g. water protection areas, low infiltration capacity of the surrounding soils or construction reasons), alternative construction methods like channelled water management exists (Fig 1.6).

## 1.5. Research objectives

The aim of this thesis is to assess the metal retention capability of existing and newly constructed highway embankment soils from infiltrating road runoff.

As a first step, a comprehensive literature review was performed to systematically gather and compare metal concentrations (Cd, Cr, Cu, Ni, Pb and Zn) in highway embankment soils and soil solutions of the European road network. The objectives of this analysis are to:

- describe the current state of knowledge in metal pollution and of roadside soils and soil solutions.
- give an overview of the existing metal contamination and the influencing factors.
- discuss the general risk of groundwater contamination in roadside environments.

The results of this investigation are presented in section 2: **Metals in European roadside soils and soil solution – A review.**

As the literature study revealed, many laboratory studies have been performed in order to estimate the groundwater pollution risk beneath roadside embankment soils, however no comparative study of laboratory and field measurements on metals leaching exists. Furthermore, there existed a serious knowledge gap regarding on-site investigations of particle-bound metal transport in roadside soils. In order to investigate these issues different laboratory and field experiments were performed.



In section 3 (**Metal leaching in a highway embankment on field and laboratory scale**), the following questions are discussed:

- How effective is the retention of dissolved and particle-bound metals in embankment soils?
- What is the share of particle-bound metals in soil solution?
- Are results from laboratory experiments comparable to field measurements?
- Does the retardation capacity of embankment soils change after long-term highway operation?

Evolving requirements on the bearing capacity of newly constructed embankments make it necessary to use materials consisting of an accurately defined gravel-soil mixture. The increased gravel content could decrease sorption capacity of the embankment soils and increase the importance of transport mechanisms like preferential flow and particle-bound metal transport.

Another important issue in terms of an integrated investigation on metal retention from road runoff in embankment soils is the question of the extant metal loads. As a third step, lysimeter experiments were performed to answer the following questions:

- Are the total and dissolved metal concentrations in the soil solution of gravel embankments increased compared to a reference embankment soil?
- Is there an elevated risk of metal concentrations exceeding legal limits for soil solution in gravel embankments?
- What metal loads occur beneath different embankment soils used for runoff infiltration?

The investigations conducted and their related results are presented in section 4: **Assessment of metal retention in newly constructed highway embankments**.

In a synthesis (section 5) the main results of the studies are summarized in order to draw a general conclusion of the research work performed. The aim is to integrate the findings of the different studies, to derive specific recommendations for action and to determine future research aspects.

## 1.6. Methods

### 1.6.1. Literature review

To describe the current state of the art a literature review on metal pollution of roadside soils was conducted. The data used in section 2 were collected from 64 different studies related to metal pollution in roadside soils and soil solution. Information on metal concentrations (Cd, Cr, Cu, Ni, Pb and Zn) in soil, the sampling depth and distance to the road, the study location, average annual daily traffic (AADT), analysed elements and digestion chemicals were collected. Data regarding the soil solution quality were also summarized even though only four studies contained information on soil solution concentrations from on-site measurements.

The data collected on soil metal concentrations were summarized in one big data set. In order to synthesise the compiled information, metal concentrations, pH and LOI (loss of ignition) were grouped into three different categories based on distance and depth (Fig. 1.8). After classification, the data set was analysed with respect to total and relative concentration changes at different depths and distances. Furthermore, a Pearson correlation analysis was conducted to identify the importance of the different influencing factors on metal concentrations in roadside soils.

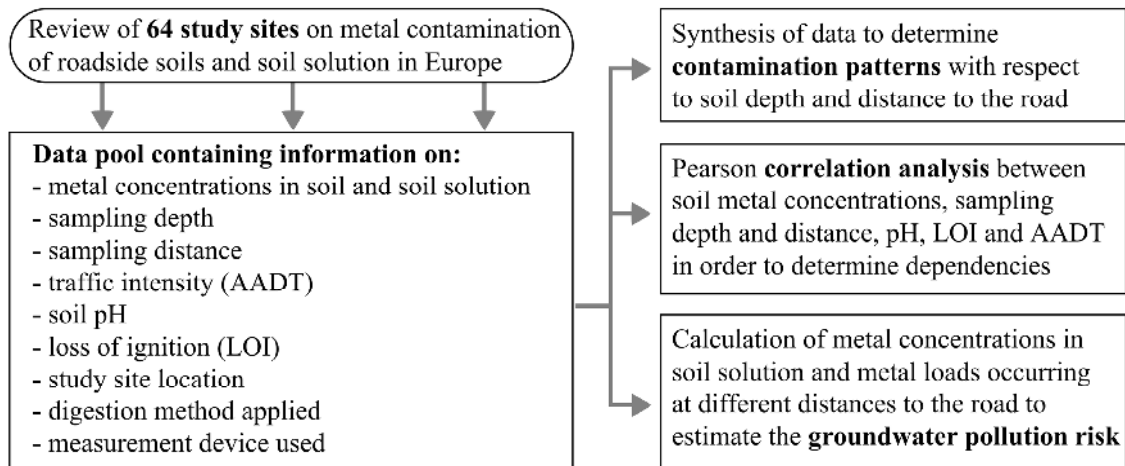

Fig. 1.8: Visualisation of the approach of the data synthesis conducted in the review study.

To evaluate the soil solution data a distinction was made between highway sites and main road sites. Median metal concentrations in soil solution were calculated for three different distances at 50-cm depth. On the basis of the results obtained, the general risk of groundwater pollution due to metal contamination of roadside soils was estimated.

### 1.6.2. Field and laboratory investigations

In order to study the metal leaching characteristics of an existing embankment a number of field and laboratory experiments were performed (section 3). The study site investigated is located at AVUS highway, Berlin, Germany. The AVUS highway has been in operation since 1921 with a current annual average daily traffic of 90.000-100.000 vehicles per day. In this section the highway is drained by a diffuse infiltration across the embankment and slope.

In order to determine the metal distribution in soil matrix samples (T=transect) were collected along a transect of 25 m x 10 m, at three different distances from the road and two different depths. Additionally a reference sample was collected at 800 m distance to the road to define the initial state of the embankment soil. To conduct the batch leaching experiments (B=batch) another representative (400 kg) soil sample was collected. Furthermore wick lysimeter boxes were installed at three roadside profiles to determine dissolved and particle-bound metal concentrations in soil solution (Fig. 1.9). The soil solution samples were gained using a hanging water column of 63 cm (wick) in the period from January to March 2008. Additionally two runoff samplers were installed; one at the beginning and one at the end of the wick lysimeter site to determine the metal concentration in the road runoff (input).



Fig. 1.9: Pictures of a rainfall event, sampling chamber and installed wick (from left to right).

To determine the changes in retardation capacity of roadside soils after nearly 90 years of highway operation, adsorption experiments with different levels of metal additions were performed with the embankment (B) and reference soil. The Freundlich-adsorption model was used to fit an adsorption isotherm to the experimental data. The different retardation factors were calculated to compare the adsorption characteristics of the embankment and reference soil.

To predict the metal mobility in roadside soils different laboratory leaching experiments (*soil saturation extracts* according to the BBodSchV, (1999); *S<sub>4</sub> Elution* according to the DIN 38414-4, 1984; *soil column experiments* based on DIN V 19736 and *calculated absorption isotherms*) were performed (Fig 1.10). The results were compared to field monitoring data documented in Kluge and Wessolek (2012) to assess the accuracy of the prognosis from the laboratory leaching experiments.



Fig. 1.10: Pictures of soil saturation extract (left) and column experiments (right).

### 1.6.3. Lysimeter studies

To measure metal concentrations in the soil solution of stable gravel embankments six PVC lysimeter tubs were installed into the embankment of the A115 highway in November 2012 (Fig. 1.11). The lysimeter site is located in the southwest of Berlin, about 10 km away from the site investigated in the field and laboratory studies described in section 4. Traffic volume at the study site ranges from 63,000 to 80,000 vehicles per day. The driving lane has a width of 15 m in each direction which is drained across the adjacent embankment and slope. The surrounding soils are mainly Spodo-Dystric Cambisols (FAO, 2006) from glacial sand deposits. Mean annual groundwater recharge rate for the adjacent area is about 180 mm calculated with the hydro-pedotransfer function of Wessolek et al. (2008).

Three of the installed lysimeters were filled with different (embankment) soil materials (Fig. 1.11). Two of the materials consist of a mixture from natural broken rock and sand and contain a large gravel fraction which guarantees the required bearing capacity. For one variant (MTB) topsoil from the surrounding area was added (15%) to the initial material, the second stable variant contains no topsoil (BCM). As a third variant a surrounding topsoil was installed as a non-stable reference (TSM). A detailed description of the materials used can be found in section 4. The soils were compacted after installation according to road construction regulations to obtain near real conditions. The installed embankment lysimeters can catch surface runoff as well as seepage water at 30 and 20 cm respectively. Three further lysimeters were intended to collect the incoming road runoff. Therefore they were only filled with plain pebble gravel.

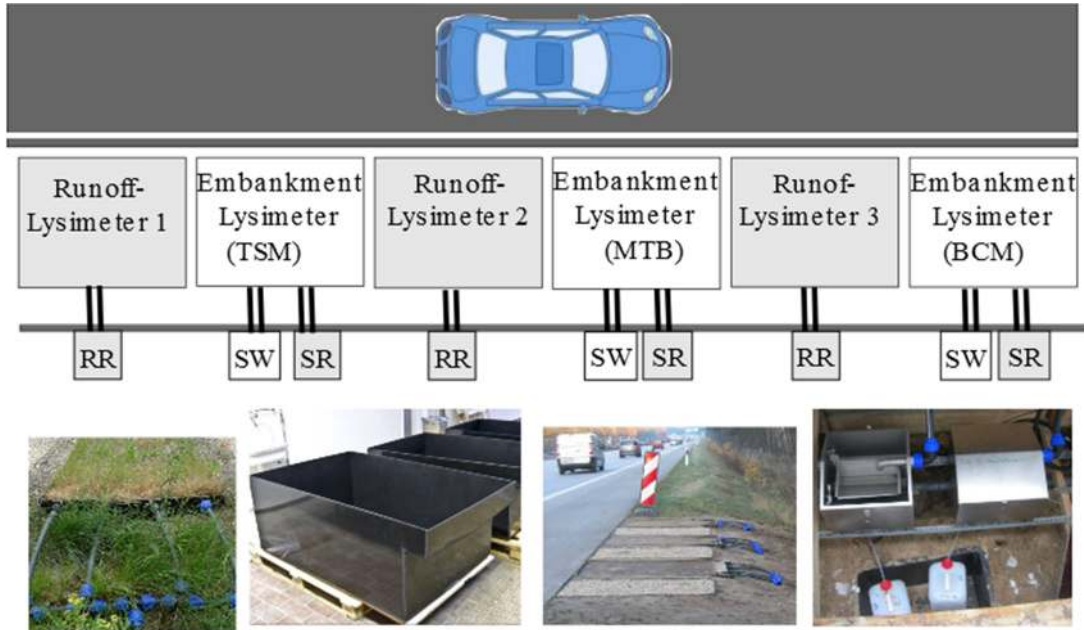

Fig. 1.11: Sketch of the lysimeter site setup (top) with sampling vessels for road runoff (RR), surface runoff (SR) and seepage water (SW). Pictures of a greened lysimeter, empty lysimeter tubes, lysimeter site right after installation and tipping buckets with sampling vessels (bottom left to right).

The lysimeter discharges were passed into tipping buckets that determined the water volume (Fig. 1.11). An aliquot of the water passing the tipping buckets was collected in PE vessels. In order to determine and compare metal concentrations in soil solution of the different embankment materials, composite samples were collected and analysed once a month. In each sample the total and dissolved ( $<0.45 \mu\text{m}$ ) metal concentrations were determined. The collected road runoff was analysed in the same way. In order to estimate metal loads transferred towards the groundwater, median concentrations of the different lysimeters were multiplied by the related runoff volume.



## **Part II: Articles**

## 2. Metals in European roadside soils and soil solution – A review<sup>1</sup>

Moritz Werkenthin\*, Björn Kluge and Gerd Wessolek

Department of Ecology, Soil Conservation, Technische Universität Berlin,  
Ernst-Reuter-Platz 1, 10587 Berlin, Germany

(\*author for correspondence, e-mail: moritz.werkenthin@tu-berlin.de, Tel.: +49 30 31473525)

### **Abstract:**

This review provides a summary of studies analysing metal concentrations in soils and soil solution at European roadsides. The data collected during 27 studies covering a total of 64 sites across a number of European countries were summarised. Highest median values of Cr, Cu, Ni, Pb and Zn were determined in the top soil layer at the first 5 m beside the road. Generally, the influence of traffic on soil contamination decreased with increasing soil depth and distance to the road. The concentration patterns of metals in soil solution were independent from concentrations in the soil matrix. At 10-m distance, elevated soil metal concentrations, low pH and low percolation rates led to high solute concentrations. Directly beside the road, high percolation rates lead to high annual loadings although solute concentrations are comparatively low. These loadings might be problematic, especially in regions with acidic sandy soils and a high groundwater table.

### **Keywords:**

Soil pollution; Soil solution concentration; Heavy Metal; Metal pattern; Highway; Metal loads

---

1 Published: Werkenthin, M; Kluge, B and Wessolek, G. *Environmental Pollution* (2014): 189, 98-110.



## 2.1. Introduction

The contamination of roadside environments of heavily trafficked main roads and highways has been a subject of investigation for more than forty years. Although regulations like the ban on leaded petrol have reduced emissions from single vehicles, this effect is negated by the increasing worldwide traffic (Monks et al., 2009). Emissions from major highways contain different kinds of contaminants such as metals, polycyclic aromatic hydrocarbons and road salts which can occur in both particulate and dissolved form. In particular, metals are of a great concern because they cannot be decomposed by micro-organisms (persistence) and have a long term toxicity for plants, animals and humans. The most recognised and examined metals in roadside environments are Cd, Cr, Cu, Pb, Ni and Zn (Münch, 1993; Folkeson et al., 2009; Kayhanian et al., 2012). But also increased concentrations of other metals like As, Co, Sb, Se, Sr and V and many others occur near heavily trafficked roads (Thorpe and Harrison, 2008). Due to its presence in vehicular brake pads especially Sb has attained much attention as a roadside contaminant in various recent publications (e.g. Hjortenkrans et al., 2008; Ceriotti and Amarasiriwardena, 2009; Kadi, 2009).

### 2.1.1. Sources of Pollution

The metals introduced into the environment by traffic derive from many different sources. Emissions resulting from traffic are caused mainly by tire wear off, break lining, wear of individual vehicular components such as the car body, clutch or motor parts and exhaust (Lindgren, 1996). Pollutants released by motor vehicles may also originate from the residues from incomplete fuel combustion, oil leaking from engine and hydraulic systems and fuel additives. Road abrasion, pavement leaching, traffic control device corrosion and road maintenance, i.e. de-icing activities are also relevant sources of pollutants (Lindgren, 1996; Hjortenkrans et al., 2007; Kluge and Wessolek, 2012). Folkeson et al. (2009) classified road traffic pollution sources into five groups: traffic & cargo, pavement & embankment material, road equipment, maintenance & operation and external sources.

A quantification of the release of individual building components is difficult because the composition varies widely, depending on the manufacturer. Nevertheless, some studies have been carried out on the release and deposition rates of particulate pollutants from motor components and road degradation (Revitt et al., 1990; Muschak, 1990; Lindgren, 1996). Furthermore, traffic related factors like road design, types of fuel used, volume of light and heavy traffic, intersections, driving speed and driving behaviour influence the emission quality.

Therefore, a very complex mixture of substances is released in roadside environments. The most widely recognised pollutants are carbon monoxide, nitrogen oxides, hydrocarbons, sulphur dioxide, methane, metals and organic pollutants (Wessolek et al., 2011).

### 2.1.2. Pathways of pollutant transport

Particulate or dissolved pollutants are transferred into the surrounding environment via aerial transport or the infiltration of road runoff and spray water (Legret and Pagotto, 2006; Bakirdere and Yaman, 2008). Figure 2.1 shows a typical view of a road with pathways of dispersion by dry and wet depositions into the roadside environment.

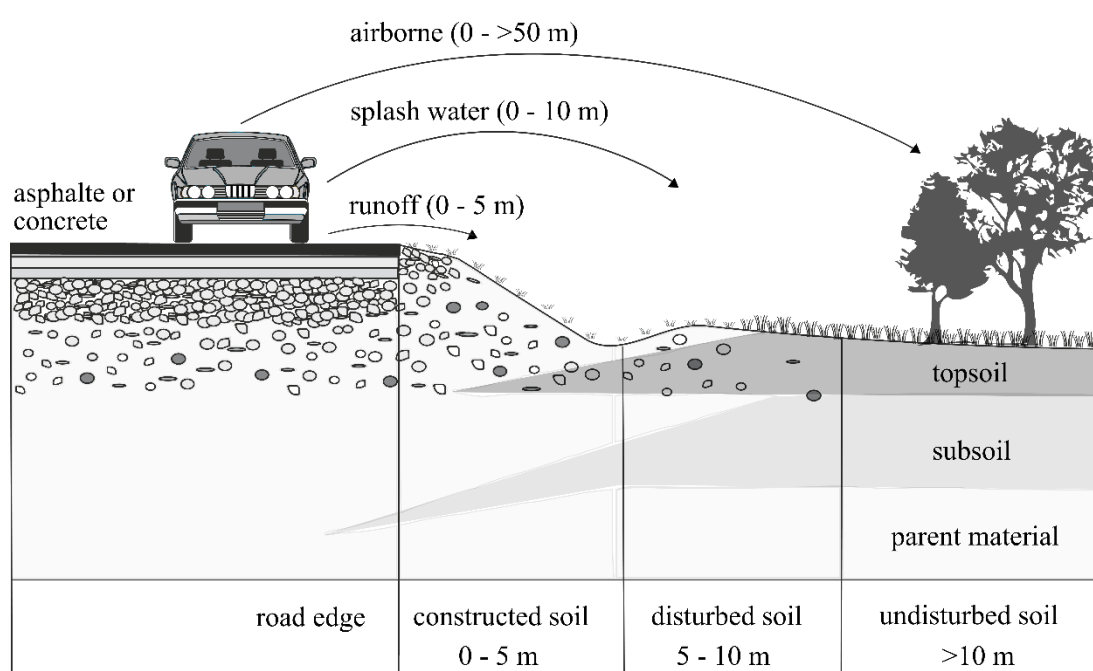

Fig. 2.1: Schematic sketch of a roadside environment and pathways for pollutant dispersion.

The pollutants are transported across the road surface with the runoff and then deposited as suspended or dissolved particles. Depending on the type of road and the inclination of the slope, spray and road runoff water can be transported as far as 10 m across the adjacent roadside area (Golwer, 1991). With the additional influence of wind and airflow, very fine particulate matter can be transported and deposited up to a distance of 250 m (Zechmeister et al., 2005). An analysis of studies on major roads and highways determined three different areas of pollution for roadside environments (Golwer, 1991). These are the area of 0-2 m, which is dominated by runoff water from the road and spray water; the area of 2-10 m, which is dominated by splash water and partly influenced by runoff water, depending on the inclination of the slope; and the area 10-50 m, which is affected mainly by airborne pollutant transport.

The composition of the road runoff and the dry deposition is affected by the traffic related factors mentioned previously as well as by environmental factors such as wind direction, amount and intensity of precipitation, previous dry periods and vegetation cover (Sansalone and Buchberger, 1997; Van Bohemen and Van de Laak, 2003).

Dry depositions affected by traffic have shown higher concentrations of metals and many organic contaminants than comparable areas in rural environments. Wet depositions in urban areas in the form of street runoff and spray water, contain high concentrations of pollutants compared to normal precipitation (Harrison et al., 1985; Makepeace et al., 1995; Wigington et al., 1986). The quality of road runoff and street dust has been studied intensively and is well documented in many publications e.g. Sternbeck et al. (2002), Harrison et al. (2003), Göbel et al. (2007) and Kayhanian et al. (2012).

### **2.1.3. Roadside soils**

The construction, use and maintenance of roads changes the original physical, biological and chemical properties of the soil in the adjacent area (Fig. 2.1). Often the topsoil was taken away during road construction or left buried beneath the base course at depths of >1 m. Roadside soils often contain up to 30% technogenic materials and stones. The presence of these materials, among other factors, like alkaline deposition from road surface, cause an increase of soil pH even higher than 7. The embankment, built during the course of the road construction, often measures up to 5 m and is located directly along the road edge (Fig. 2.1). In many cases this area also contains slopes and ditches to drain and infiltrate the runoff from the road. At the distance 5–10 m the soils often are compacted and disturbed with little to no vegetation. After this distance the influence of the road slowly decreases and after 10-15 m predominantly original soil profiles occur (for further information see Wessolek et al., 2011). Roadside soils are one of the main targets for pollutants emitted from roads and many investigations have been carried out to determine metal concentrations along European main roads and highways (Fig. 2.2). A growing awareness of the environment in the mid-1970s led to an increase of investigations in roadside environments.

The studies of Lagerwerff and Specht (1970), Laxen and Harrison (1977) and Warren and Birch (1987) in the 1970s and '80s are among the first studies to systematically investigate road traffic induced soil contamination. Lagerwerff and Specht (1970) focussed on the influence of airborne metals and their impact on roadside soils. They determined elevated metal concentrations in the soils adjacent to the road and decreasing concentrations with increasing distance and soil depth. This was confirmed in many further studies (e.g. Garcia et al., 1996; Turer et al., 2001; Hjortenkrans et al., 2008).



Fig. 2.2: Schematic map of study site locations in Europe.

The metal concentrations in roadside soils and vegetation are also correlated positively to traffic intensity as the investigations of e.g. Rodriguez-Flores and Roddriguez-Castellon (1982) and Arslan and Gizir (2006) showed. Other authors could not find a direct correlation between traffic intensity and metal concentrations in roadside soil (Perez et al., 2008). Laxen and Harrison (1977) investigated the influence of highway traffic on lead pollution of water resources. They showed that the high concentration of lead in the road runoff (up to 100 times higher than background concentrations) could be immobilised effectively by the first 10 cm of roadside soils. Other authors showed that easily mobilised trace elements like Cd and Zn can be transferred to deeper soil layers (e.g. Legret and Pagotto, 2006; Kluge and Wessolek, 2012).

#### 2.1.4. Metal mobility in roadside soils

A large part of the metals that are transferred to roadside soils are bound to particles. These particles are retained to a large extent by physical mechanisms immediately after they enter the soil and therefore mostly remain in the top horizon (Boivin et al., 2008).

The mobility of metals in roadside soils is influenced strongly by soil pH and organic matter as many authors have demonstrated (e.g. Ramakrishnaiah and Somashekar, 2002; Turer and Maynard, 2003; Kocher et al., 2005, Kluge and Wessolek 2012). Turer and Maynard (2003) found a strong positive correlation between soil organic matter and certain metal concentrations. They also could show that a large fraction of metals is bound to an insoluble form of organic matter that is probably of anthropogenic origin.

The soil pH near roads is influenced strongly by traffic activities. Especially road abrasion, which is transferred to the soil adjacent to the road, changes the pH value over time to neutral or even above neutral. The elevated soil pH in turn enhances metal retention (Kocher et al., 2005). Barbosa and Hvitved-Jacobsen (1999) pointed out that beside soil texture and composition, a high resistance to desorption at low pH positively influences metal mobility in roadside soils.

Roulier et al., (2008) studied the impact of preferential flow path in roadside soils. Preferential flow is a physical process in soils in which a fast transport of water and other compounds takes place only in a small portion of the pore system. The latter could show that an increased transport of Pb via preferential flow and DOM takes place after intensive rainfall events (21.9 mm in 3 h). It is well-known that Pb and certain other metals form very stable complexes with functional groups of humic substances and Fe and Mn oxides and oxyhydroxides because of the high adsorption capacities of these compounds (Jordan et al., 1997; Hasselov and von der Kammer, 2008). Kretzschmar and Sticher (1997) could show that humic-coated Fe oxide colloids facilitate the transport of Pb<sup>2+</sup> and Cu<sup>2+</sup> in the presence of high Ca<sup>2+</sup> concentrations, which often occurs in road runoff.

In several studies (e.g. Legret and Pagotto, 2006; Hjortenkrans et al., 2008), the mobile fraction of soil metals was determined. The latter could show that more than 40% of the total concentrations for Cd, Cu, Ni, Pb and Zn can be counted as part of the mobile fraction. This metal fraction is mobilised easily if soil is disturbed or extreme weather conditions like dry periods (oxidation) or long intensive rain periods (reducing condition) occur. Legret and Pagotto (2006) determined a high risk of transfer to plants and groundwater from polluted soils especially for Pb. Othman et al., (1997) could show that the Pb level of plants growing close to roads was higher than the natural level. The metal uptake of plants is affected by element mobility in soil, essentiality for plants and plant species. Metal levels in plants decreased with increasing distance from the road (Zechmeister et al., 2005; Modlingerova et al., 2012).

The use of de-icing agents for road maintenance promotes a high dispersion and leaching of organic matter in roadside soils. Under these conditions, Arnheim et al. (1992) concluded from soil column experiments that dispersion is the dominant mechanism of metal mobilisation. Arnheim et al. (1992) also showed that NaCl from de-icing salts could promote colloid assisted transport of metals. Bäckström et al. (2004) observed the influence of de-icing salts on metal mobility in field lysimeter. They also determined a clear positive relation between the application of de-icing agents and Cd, Cu, Pb and Zn concentrations in soil solution. Although mobilisation mechanisms were diverse and sometimes even counteracting.

Another aspect of road maintenance is to ensure road de-watering. In some European countries e.g. Germany it is common to remove the top layer of the embankment (2-5 cm) about every 5-12 years. As a result of this procedure a considerable amount of metals is relocated or removed from the roadside environment (Kocher et al., 2008).

#### **2.1.5. Soil solution**

There are only few studies that examined the metal concentrations in soil solution near highly trafficked roads (Reinirkens, 1996; Dierkes and Geiger, 1999; Bäckström et al., 2004; Kocher et al., 2005; Kluge and Wessolek, 2012). The relationship between metals in soil solution and roadside soils was analysed by Reinirkens (1996) with field lysimeter. He concluded that the displacement of the different metals is variable and that the compounds of metals emitted by road traffic are fixed mainly in the soil.

In studies performed on different roadside locations, Kocher et al. (2005) showed that high concentrations in the soil matrix do not necessarily lead to increased soil solution concentrations.

Nonetheless high percolation rates near the road edge could cause a remarkable transfer of metal loadings and increase the risk of groundwater pollution. Furthermore, the study of Kluge and Wessolek (2012) showed that soil solution concentrations increase with distance due to decreasing percolation rates and lower soil pH.

#### **2.1.6. Objectives**

There are multiple studies regarding the impact of highways on the environment, but at present no literature study has systematically gathered and compared the quantitative data of metal concentrations in roadside soils and soil solutions of European road networks. Therefore, this study focuses on the following objectives:

- A comparison of metal concentrations in the soils and soil solutions of European roadside environments.
- Analysing the data with regards to various impact factors like (I) distance and depth, (II) soil characteristics such as pH and loss on ignition (LOI) and (III) traffic intensity.
- An analysis and discussion of soil and groundwater pollution risk in roadside environments.

## 2.2. Methods

### 2.2.1. References and characteristics of monitoring sites

The data presented in this paper were collected from different studies related to metal concentrations in roadside soils and soil solution. Since Cd, Cr, Cu, Ni, Pb and Zn are the most studied metals in roadside environments only data concerning these elements will be considered in the following. In Table 2.1 information about the papers referenced, study location, average annual daily traffic (AADT), analysed elements and digestion chemicals is summarised. Despite intensive research, the list in Table 2.1 may not include all studies published on metal pollution of the roadside environment in Europe. A large part of the investigations were carried out in Northern and central Europe. The AADT of the study sites varied between 3200 and 120,600. Speed limit and main soil type were determined only in about half of the studies and only four publications contain information regarding soil solution quality from on-site measurements.

All soil samples were dried and sieved through a 2-mm sieve, except Jankaitė et al. (2008) (1 mm). Sampling depth and distance of the studies varied widely. Total concentrations of Cd, Cr, Cu, Ni, Pb and Zn of the soil samples were determined after digestion with acids and mixed acids such as HNO<sub>3</sub>, HCl + HNO<sub>3</sub>, HF + HCl, etc.. The extraction rate of the analysed metals depends on the acid/ acid mixture used. Digestions using HF completely decompose resistant minerals releasing the total metal content, whereas digestions using Aqua Regia and HNO<sub>3</sub> release the more exchangeable metal fractions. In particular this is important for Cr content since some Cr bearing minerals are very difficult to decompose (Lamble and Hill, 1998).

Element concentrations were determined with flame atomic absorption spectroscopy, electrothermal atomic absorption spectroscopy, anodic stripping voltammetry, inductively coupled plasma mass spectrometry, inductively coupled plasma optical emission spectroscopy and X-ray fluorescence spectroscopy. In the composed articles metals were determined in the following frequency Pb, Zn>Cu>Cd>>Cr>Ni. More information on the study sites and soil sampling can be found in the supplementary material.

Tab. 2.1: Register of referenced studies.

Reference	AADT	Location	Analysed elements	Digestion
Warren and Birch (1987)	70,000	London (GB)	Cd, Cu, Pb, Zn	HNO <sub>3</sub> + HClO <sub>4</sub>
Ward (1990)	110,000	Central England (GB)	Cd, Cr, Cu, Ni, Zn	HNO <sub>3</sub> + HF
	75,000	Birmingham (GB)	Cd, Cr, Cu, Ni, Zn	HNO <sub>3</sub> + HF
	120,000	London (GB)	Cd, Cr, Cu, Ni, Zn	HNO <sub>3</sub> + HF
Münch (1993)	3200	Dortmund (D)	Cd, Cr, Cu, Ni, Pb, Zn	Aqua Regia
Garcia et al. (1996)	19,200	San Sebastian (E)	Cd, Cr, Cu, Ni, Pb, Zn	Aqua Regia
	9500	San Sebastian (E)	Cd, Cr, Cu, Ni, Pb, Zn	Aqua Regia
	4000	San Sebastian (E)	Cd, Cr, Cu, Ni, Pb, Zn	Aqua Regia
	11,000	San Sebastian (E)	Cd, Cr, Cu, Ni, Pb, Zn	Aqua Regia
	4000	San Sebastian (E)	Cd, Cr, Cu, Ni, Pb, Zn	Aqua Regia
Reinirkens (1996)	-	North-Rhine-Westphalia (D)	Cd, Cu, Pb, Zn	Aqua Regia
	-	North-Rhine-Westphalia (D)	Cd, Cu, Pb, Zn	Aqua Regia
Dierkes and Geiger (1999)	107,600	Gelsenkirchen (D)	Cd, Cu, Pb, Zn	Aqua Regia
	93,7000	Mülheim (D)	Cd, Cu, Pb, Zn	Aqua Regia
	78,000	Gladbeck (D)	Cd, Cu, Pb, Zn	Aqua Regia
	79,900	Oberhausen (D)	Cd, Cu, Pb, Zn	Aqua Regia
	52,000	Bottrop (D)	Cd, Cu, Pb, Zn	Aqua Regia
Pihl and Raaberg (2000)	22,000	Rud (DK)	Cr, Pb, Zn	-
	29,000	Vejenbrod (DK)	Cr, Pb, Zn	-
Kocher and Wessolek (2002)	70,000	Hannover (D)	Cd, Cr, Cu, Ni, Pb, Zn	Aqua Regia
	70,000	Hannover (D)	Cd, Cr, Cu, Ni, Pb, Zn	Aqua Regia
	50,000	Hannover (D)	Cd, Cr, Cu, Ni, Pb, Zn	Aqua Regia
	90,000	Berlin (D)	Cd, Cr, Cu, Ni, Pb, Zn	Aqua Regia
	20,000	Celle (D)	Cd, Cr, Cu, Ni, Pb, Zn	Aqua Regia
	20,000	Braunschweig (D)	Cd, Cr, Cu, Ni, Pb, Zn	Aqua Regia
	20,000	Braunschweig (D)	Cd, Cr, Cu, Ni, Pb, Zn	Aqua Regia
Bäckström et al. (2004)	7,400	Svanenberg (S)	Cd, Cu, Pb, Zn	-
	15,600	Norsholm (S)	Cd, Cu, Pb, Zn	-
Viard et al. (2004)	40,000	Nancy (F)	Cd, Pb, Zn	Aqua Regia
	60,000	Nancy (F)	Cd, Pb, Zn	Aqua Regia
Grigalaviciene et al. (2005)	13,800	Kaunas-Vilnius (LT)	Cd, Cu, Pb	Aqua Regia
Mangani et al. (2005)	13,200	Urbino (I)	Cd, Cu, Pb, Zn	HF + HCl + HNO <sub>3</sub>
	13,200	Urbino (I)	Cd, Cu, Pb, Zn	HF + HCl + HNO <sub>3</sub>
Pleniscar and Zupancic (2005)	14,000	Ljubljana-Krakovski gozd (SLO)	Cd, Cu, Ni, Pb, Zn	HCl + HNO <sub>3</sub> + H <sub>2</sub> O
	13,000	Ljubljana-Druzinska vas (SLO)	Cd, Cu, Ni, Pb, Zn	HCl + HNO <sub>3</sub> + H <sub>2</sub> O
	15,400	Ljubljana-Dob (SLO)	Cd, Cu, Ni, Pb, Zn	HCl + HNO <sub>3</sub> + H <sub>2</sub> O
	28,500	Ljubljana-Ivancna Gorica (SLO)	Cd, Cu, Ni, Pb, Zn	HCl + HNO <sub>3</sub> + H <sub>2</sub> O
	14,000	Ljubljana-Dedni Dol (SLO)	Cd, Cu, Ni, Pb, Zn	HCl + HNO <sub>3</sub> + H <sub>2</sub> O
Akbar et al. (2006)	-	North and west Yorkshire (GB)	Cd, Cu, Pb, Zn	Aqua Regia
Hjortenkrans et al. (2006)	17,000	South Sweden (S)	Cd, Cr, Cu, Ni, Pb, Zn	Aqua Regia
Legret and Pagotto (2006)	24,000	Nantes (F)	Cd, Cr, Cu, Pb, Zn	HF + HCl
	21,000	Paris (F)	Cd, Cr, Cu, Pb, Zn	HF + HCl
Steiner et al. (2007)	17,000	Burgdorf near Bern (CH)	Cd, Cu, Pb, Zn	-
Bakirdere and Yaman (2008)	-	Elazig (TR)	Cd, Cu, Pb	HNO <sub>3</sub> + H <sub>2</sub> O <sub>2</sub>
	-	Elazig (TR)	Cd, Cu, Pb	HNO <sub>3</sub> + H <sub>2</sub> O <sub>2</sub>



Reference	AADT	Location	Analysed elements	Digestion
	-	Elazig (TR)	Cd, Cu, Pb	HNO <sub>3</sub> + H <sub>2</sub> O <sub>2</sub>
	-	Elazig (TR)	Cd, Cu, Pb	HNO <sub>3</sub> + H <sub>2</sub> O <sub>2</sub>
Boivin et al. (2008)	19,000	Riddes (CH)	Cr, Cu, Ni, Pb, Zn	HNO <sub>3</sub>
	15,750	St Leonard (CH)	Cr, Cu, Ni, Pb, Zn	HNO <sub>3</sub>
Hjortenkrans et al. (2008)	22,300	Kalmar (S)	Cd, Cr, Cu, Ni, Pb, Zn	Aqua Regia
	20,700	Varberg (S)	Cd, Cr, Cu, Ni, Pb, Zn	Aqua Regia
Jankaitė et al. (2008)	-	Žiežmariai (LT)	Cr, Cu, Ni, Pb, Zn	HNO <sub>3</sub> + H <sub>2</sub> O <sub>2</sub>
	-	Vilnius-Panevėžys (LT)	Cr, Cu, Ni, Pb, Zn	HNO <sub>3</sub> + H <sub>2</sub> O <sub>2</sub>
	-	Vilnius-Varėna (LT)	Cr, Cu, Ni, Pb, Zn	HNO <sub>3</sub> + H <sub>2</sub> O <sub>2</sub>
	-	Vilnius-Utena (LT)	Cr, Cu, Ni, Pb, Zn	HNO <sub>3</sub> + H <sub>2</sub> O <sub>2</sub>
	-	Vilnius-Prienai (LT)	Cr, Cu, Ni, Pb, Zn	HNO <sub>3</sub> + H <sub>2</sub> O <sub>2</sub>
Christoforidis and Stamatis (2009)	Low	Kavala rural (GR)	Cd, Cr, Cu, Ni, Pb, Zn	HNO <sub>3</sub>
	Heavy	Kavala urban (GR)	Cd, Cr, Cu, Ni, Pb, Zn	HNO <sub>3</sub>
Zehetner et al. (2009)	20,000	Vienna (A)	Cd, Cr, Cu, Ni, Pb, Zn	Aqua Regia
Stevovic et al. (2010)	-	Pancevo (SRB)	Cd, Cr, Ni Pb	HNO <sub>3</sub>
Deska et al. (2011)	9000	Sidlce E30 (PL)	Cd, Pb	HNO <sub>3</sub>
Kluge and Wessolek (2012)	100,000	Berlin (D)	Cd, Cu, Pb, Zn	Aqua Regia
Modlingerova et al. (2012)	20,000	Prague (CZ)	Cd, Cr, Cu, Ni, Pb, Zn	Aqua Regia

### 2.2.2. Compilation and data synthesis

The metal concentration patterns of roadside soils were grouped into three different categories in terms of distance and depth. The following areas were defined. Distance: 0–<5 m, 5–<10 m and 10–25 m; depth: 0–5 cm, 5–<15 cm and 15–<70 cm. From each study site metal concentrations in soil at three different distances and three different depths were considered in the compiled data, if recorded in the study. For the evaluation of vertical concentration patterns, the soil profile closest to the road edge was considered up to a distance of 5 m. Horizontal concentration patterns were created with data from the uppermost soil layer. Where information regarding distance and depth was defined as “topsoil” and “close to drainage ducts”, these were converted to 2.5 cm depth and 2.5 m distance respectively.

If more than one data set of a study site matched one of the defined zones, the median value subsequently was used to prevent single sites having a disproportionate impact on the results. Several authors published their results only as figures, therefore concentrations were estimated carefully on the provided graphs (Viard et al., 2004; Grigalaviciene et al., 2005; Akbar et al., 2006; Steiner et al., 2007; Zehetner et al., 2009). If necessary the median metal concentrations, pH and LOI were formed from individual values or given ranges. In some studies only Corg values were documented, which were converted into LOI for the purposes of this study by multiplying by two. This is based on the assumption that organic matter contains 50% carbon.

According to Pribyl (2010), who reviewed studies over the last 120 years, this is altogether accurate for many soils, although a single-number conversion factor clearly has the potential for error. The metal concentrations in soil at sampling points furthest from the road edge (and at least 30 m away) were assumed to represent background concentration levels if not defined otherwise. From these data median European background concentrations were estimated. For the evaluation of the soil solution data a distinction was made between highway (HW) sites (AADT 50,000–120,000) and main road (MR) sites (AADT 7000 – 20,000). Median metal concentrations in soil solution at 50-cm depth at different distances (1 m, 2.5 m, 5 m, 10 m) to the road were extrapolated. Different depths were not taken into consideration due to limited data availability. Only studies with data from on-site measurements were included.

## 2.3. Results

### 2.3.1. Metals in roadside soils

The accumulation of the emitted metals in the roadside soils is related to soil type, vegetation, wind direction, road exposure, road drainage, road distance and depth, frequency and amount of rain events and particle size of the pollutants. The continuous enrichment of pollutants in roadside soils exposes vegetation, animals and soil micro-flora to long lasting stress but seldom causes acute toxic effects. Furthermore the long-term contamination of soils can lead to locally elevated concentrations of metals in soil solution and groundwater (Trombulak and Frissell, 2000; Kocher et al., 2005).

#### **Influence of distance**

Distance related soil sampling is the investigation strategy most often employed to determine pollution patterns of roadside environments. The decrease of metal concentrations with distance to the road is well documented by many authors (e.g. Motto et al., 1970; Li, 2006; Hjortenkrans et al., 2008). Figure 2.3 shows metal concentrations of the topsoils (0–5 cm) as functions of distance from the roadside edge.

#### ***Concentrations at distance 0–<5 m from the road edge***

The concentrations are highest next to the road (0–<5 m) and show the largest deviation. At this distance, the median concentrations of Cd, Cr, Cu, Ni, Pb and Zn are 0.73, 28.0, 47.9, 24.5, 106.0 and 179.5 mg kg<sup>-1</sup>, respectively. The observed concentration ranges of the metals are 0.1–10.5, 0.42–240.3, 7–413, 2.7–228, 5.1–1769 and 25–1580 mg kg<sup>-1</sup>, respectively.

The elevated pollution level of the soil directly adjacent to the road could be explained by the highest input rates of trace elements with airflow, runoff- and splashing water in this area. According to Steiner et al. (2007), road runoff and spray water, including significant loads of pollutants, reach the soil up to a distance of 5 m, including embankment, slope and ditch if present. Kocher et al. (2005) determined a runoff-influenced area of 1.5-m distance.

Airborne particulate transport of metals can take place largely unhindered because there is usually no dense vegetation established that close to the road that could restrain the pollutants (Grigalaviciene et al., 2005; Folkesson et al., 2009). Furthermore, traffic control devices often are located in this area. The leaching of galvanised crash barriers and road signs by rain and splashing water releases a considerable amount of Zn, Cd and Cu. This action leads to highly local soil contamination (Van Bohemen and Van de Laak, 2003; Legret and Pagotto, 2006; Kluge and Wessolek, 2012).

The median metal concentrations at 0–<5 m distance are all significantly higher than composed median European background concentrations (Fig. 2.3). Trace element concentrations of the individual studies mostly exceeded their specific background concentrations if documented (see supplementary material for more details, Tab. S1). In some studies e.g. Bakirdere and Yaman (2008) and Jankaitė et al. (2008), the background concentrations of certain metals are higher than in soil adjacent to the road. This result could be due to soil transfer processes during road construction and embankment maintenance (Modlingerova et al., 2012). At this distance median concentrations of Cu, Pb and Zn exceed the Dutch target values (Cd 0.8, Cr 100, Cu 36 Ni 35, Pb 85 and Zn 140 mg kg<sup>-1</sup>), which are limit values for pollutants in soils stemming from road traffic (Van Bohemen and Van de Laak, 2003).

### *Concentrations at distance 5–<10 m from the road edge*

At the distance between 5 and <10 m, all median metal concentrations decrease compared to 0–<5 m. The median concentrations of Cd, Cr, Cu, Ni, Pb and Zn are 0.39, 9.98, 15.05, 9.9, 40.6 and 179.5 mg kg<sup>-1</sup>. Ni and Cr reach composed background concentrations, whereas Cd, Cu, Pb and Zn still exceed the median background concentrations (Fig. 2.3). Increased metal concentrations in soil in this area are caused mainly by splashing water and the airborne transport of road and traffic-related particles (Golwer, 1991; Steiner et al., 2007). The Dutch target values are not exceeded at this distance.

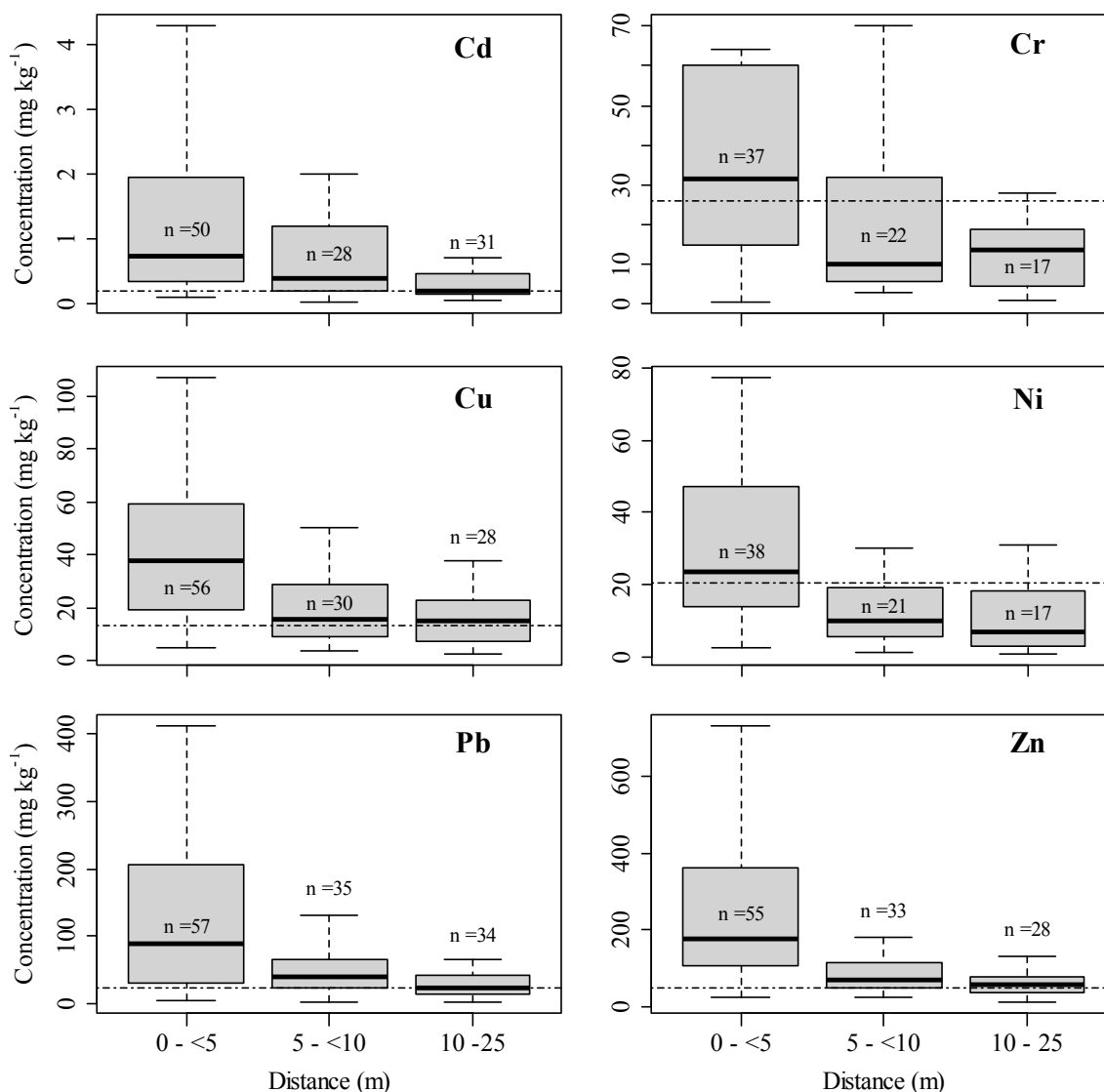

Fig. 2.3: Metal concentrations in roadside soils at 0 – 5 cm soil depth as a function of distance to the road edge (median: bold line, upper & lower quartile: grey box and upper & lower interquartile dashed lines, outliers are not displayed). Dotted horizontal line: composed European median background concentrations. The data are taken from the studies listed in Tab. 2.1.

### *Concentrations at distance 10–25 m from the road edge*

Between 10 and 25 m, metal concentrations continue to decline except for Cr, which shows a slightly higher concentration than at the area 5 - <10 m. Observed concentrations of Cd, Cr, Cu, Ni, Pb and Zn are 0.2, 13.82, 15.05, 6.93, 24.0 and 57.7 mg kg<sup>-1</sup>, respectively. Median trace element concentrations reach composed background concentrations at this distance except for Zn and Cu, which slightly exceeded the background concentration (Fig. 2.3). Median concentrations at this distance do not exceed the Dutch target values. In this area, splashing and runoff water hardly affected metal concentrations of the soil.

Airflow is the predominant transport path of metal distribution. Airborne pollutant transport depends on many factors e.g. geomorphological position of the road, wind direction, wind velocity, vegetation cover and atomic masses of the metals (Zinkutė et al., 2007; Jankaitė et al., 2008).

The distance to which an influence of road traffic on metal concentrations in soil is detectable can therefore differ greatly. Münch (1993) found background concentrations at 10 m distance from the road edge, whereas Legret et al. (1996) and Turer and Maynard (2003) determined an impact of highway induced metal soil contamination up to 25 m distance. Viard et al. (2004) could even detect traffic-related Pb contamination at a distance of 320 m from the road.

### *Relative change with distance to the road edge*

The relative change of median metal concentrations as a function of the distance from the road is shown in Fig. 4. Compared to concentrations on the road edge (0–<5 m), trace element concentrations decreased at a distance between 5 and <10 m by 46–68%. Changes of metal concentrations at a distance between 10 and 25 m varies between a decrease of 26% for Cd to an increase of 14% for Cr. The largest overall decrease with increasing distance is observed for lead (78%), whereas Cr shows the least relative decrease (66%, 51% respectively) as shown in Fig. 2.4. For the elements Cd, Cu, Ni, Pb and Zn 100%, 80%, 81%, 84% and 88% of the evaluated studies showed a decrease in soil concentrations with increasing distance. The rapid decline of metal concentrations within the area of 0–<10 m distance from the road edge was determined by several authors e.g. Münch (1993), Steiner et al. (2007) and Zehetner et al. (2009).

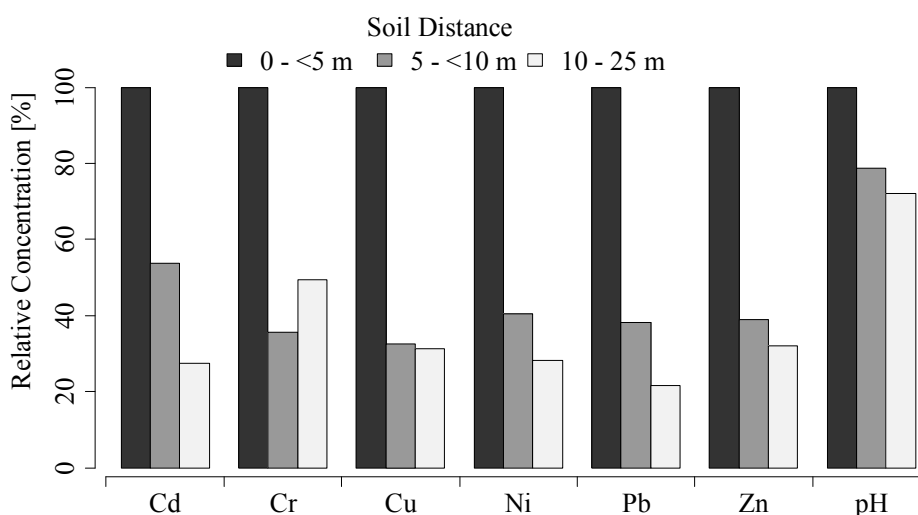

Fig. 2.4: Median soil pH and metal concentrations at 5–<10 m and at 10–25 m distance to the road edge relative to concentrations at 0–<5 m.

The reduction of runoff and splashing water infiltration within this area leads to decreasing soil concentrations. Several studies showed that the concentration patterns of the single elements can be contrary. The decrease of a certain metal with increasing distance does not imply a decrease of the other metals. This is probably due to different sources for metal emissions (Pal et al., 2011; Kluge and Wessolek, 2012). The increase of at least one trace element with increasing road distance was observed in almost 50% of the studies. A decrease in concentration was occurred only in 60% of the studies that analysed Cr contamination patterns up to a distance between 10–25 m. Additionally Cr concentrations only slightly exceeded the median background value.

These findings indicate that Cr emissions through road traffic are very low. The median soil pH decreased with increasing distance to the road by 11% (5–<10 m) and 18% (10–25 m), respectively. The elevated soil pH close to the road edge (0–<5 m) is caused mainly by alkaline depositions from road abrasion and brake linings. Among elements and compounds typically associated with crustal material important components of road dust samples are Ca, Fe and organic carbon (Thorpe and Harrison, 2008). This effect was observed by several authors (e.g. Kocher et al., 2005; Grigalaviciene et al., 2005).

### **Influence of soil depth**

Concentration gradients across different soil depth are another sampling strategy that is applied often to evaluate the contamination level of roadside soils. The median metal concentrations in roadside soils (distance: 0–5 m) at different depths are shown in Figure 2.5.

#### ***Concentrations in 0–<5 cm soil depth***

In this depth, the median concentrations of Cd, Cr, Cu, Ni, Pb and Zn are 0.8, 27.5, 46, 25.5, 95.8 and 190 mg kg<sup>-1</sup>, respectively. The observed concentration ranges of the metals are 0.1–10.7, 0.42–290.3, 7–413, 2.7–314, 5.1–1453 and 25–2618 mg kg<sup>-1</sup>. Trace element concentrations were highest in the top horizon (0–<5 cm) except for Cd, which is the most mobile of the elements analysed. It is therefore transferred easily into deeper soil layers. This result corresponds to the findings of Hjortenkrans et al. (2008) and Kluge and Wessolek (2012). In this depth, median Cu, Pb and Zn concentrations exceed the Dutch target values. However, a clear vertical concentration pattern could not be identified in all study sites. One important reason for increased metal concentrations in the top soils is physical retardation of particulate bound trace elements (Boivin et al., 2008). Another factor is the content of organic matter, which is usually highest in the upper soil layer and which is known to improve metal retention especially for Pb, Cd, Cu and Zn (Turer et al., 2001). Furthermore, the transfer of road abrasion to the soil, changing the pH value to neutral or even above neutral, reduces metal mobility (Kocher et al., 2005).

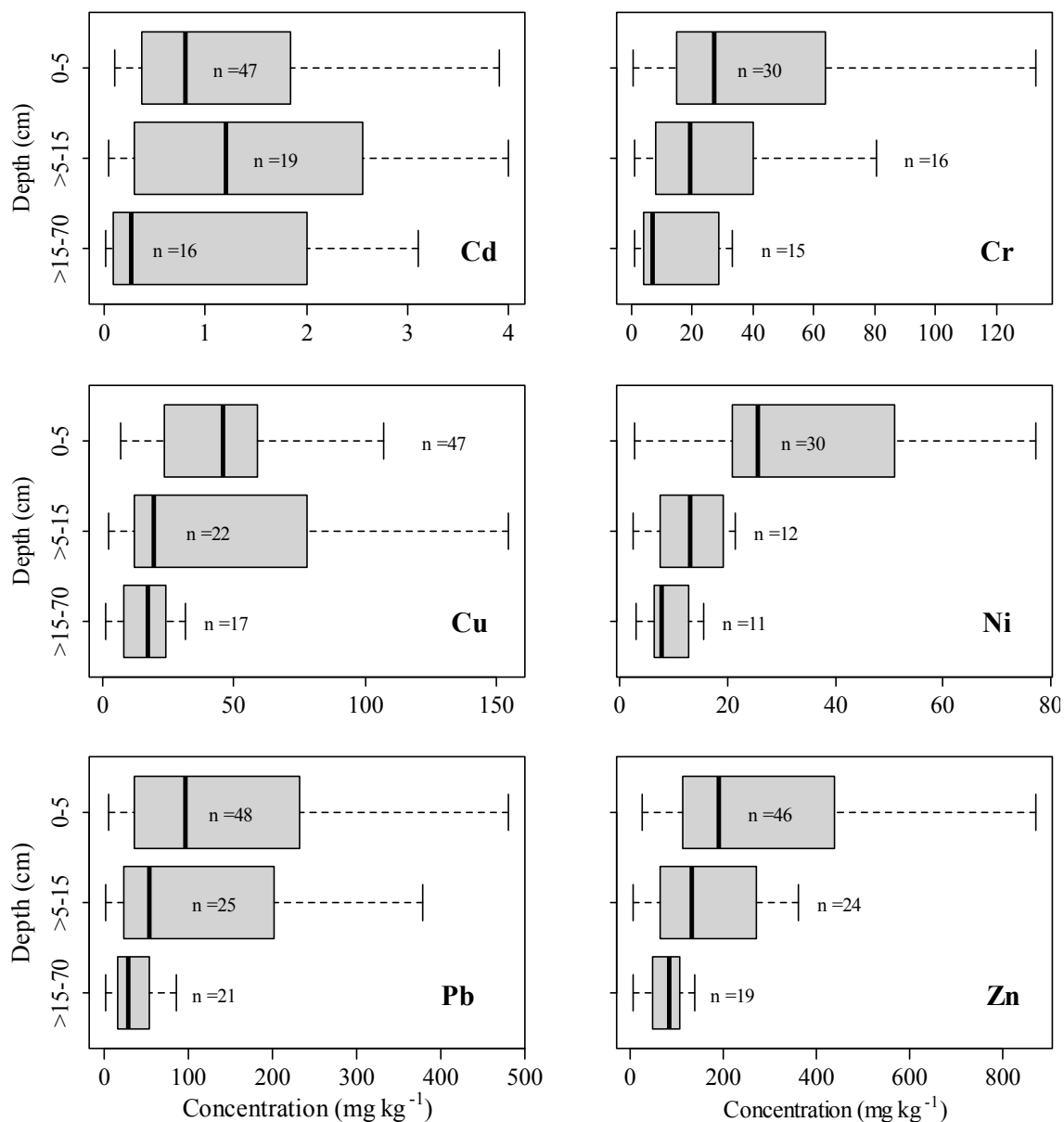

Fig. 2.5: Metal concentrations of roadside soils at 0 – 5 m distance as a function of soil depths (median: bold line, upper & lower quartile: grey box and upper & lower interquartile dashed lines; outliers are not displayed). The data are taken from the studies listed in Tab. 2.1.

### *Concentrations in 5–<15 cm soil depth*

The median concentrations of Cd (1.2), Cr (19.1), Cu (19.6), Ni (13.1), Pb (53) and Zn (130.5) mg kg<sup>-1</sup> in a depth between 5 and <15 cm are all higher than in the underlying horizon (>15–70 cm). For Cd the highest median concentrations were in this layer.

Median Cd concentration exceeds the Dutch target value in this depth, whereas median Cr, Cu, Ni, Pb and Zn concentrations were below the Dutch target values. For Cd, Cu and Pb a not insignificant number of studies determined metal concentrations that are higher than the determined median value (Fig. 2.5).

The transfer of these elements into deeper soil layers could be fostered by the intensive use of de-icing salts. Several authors found a strong positive correlation between the use of de-icing salts and the mobility of DOC and metals, especially for Cd, Cu, Pb and Zn (e.g. Amrhein et al., 1992; Ramakrishna and Viraraghavan, 2005; Green et al., 2009). The authors explained this action by the fact that Pb and particularly Cu form organic complexes and are transported with DOC and dispersed colloids. Cd and Zn experience a competitive cation exchange and a formation of chloride and acetate complexes, enhancing mobilisation. Hjortenkrans et al. (2008) explained elevated Pb concentrations in deeper soil layers by the ban on Pb use in petrol and an annual sand deposition on roads during winter time.

### ***Concentrations in 15–70 cm soil depth***

The lowest median concentrations of Cd (0.27), Cr (6.9), Cu (19.6), Ni (7.7), Pb (28) and Zn (82.5) mg kg<sup>-1</sup> are in the depth between 15 and 70 cm (Fig 2.5). In this depth, median metal concentrations did not exceed the Dutch target values. The smallest variation in trace element contents in soil is also apparent in this soil layer. Although median Cd concentration is lowest in this horizon, a considerable share of the analysed soils has concentrations above the median value as indicated by Figure 2.5.

This result indicates that the influence of road traffic-induced metal emissions on soil is limited in this depth and, except for Cd, almost negligible. This is in line with the findings of earlier studies. The penetration depth determined by Legret and Pagotto (2006), Steiner et al., (2007) and Motuzas et al. (2008) ranged between 30 and 40 cm. Dierkes and Geiger (1999) and Hjortenkrans et al. (2008) could detect an influence of road traffic only in the upper 15 cm.

### ***Relative change with increasing soil depth***

In comparison with metal concentration in the topsoil layer (0–<5), the relative change of trace element concentrations at 5–<15 cm depth varied widely. For Cd an increase of 50% was determined, whereas Cu concentrations decreased by 57% (Fig. 2.6). In the soil layer 15–75 cm all median metal concentrations decreased between 57% and 75%, compared to topsoil concentrations. At soil depths between 10 and 30 cm Dierkes and Geiger (1999) determined a reduction of Cu, Pb and Zn concentrations ranging from 75% to 93%, for Cd the reduction was much less (30%–40%). The change of metal concentrations at 35 cm depth found by Boivin et al. (2008) varied between a decrease of 54% for Zn and an increase of 9% for Ni.



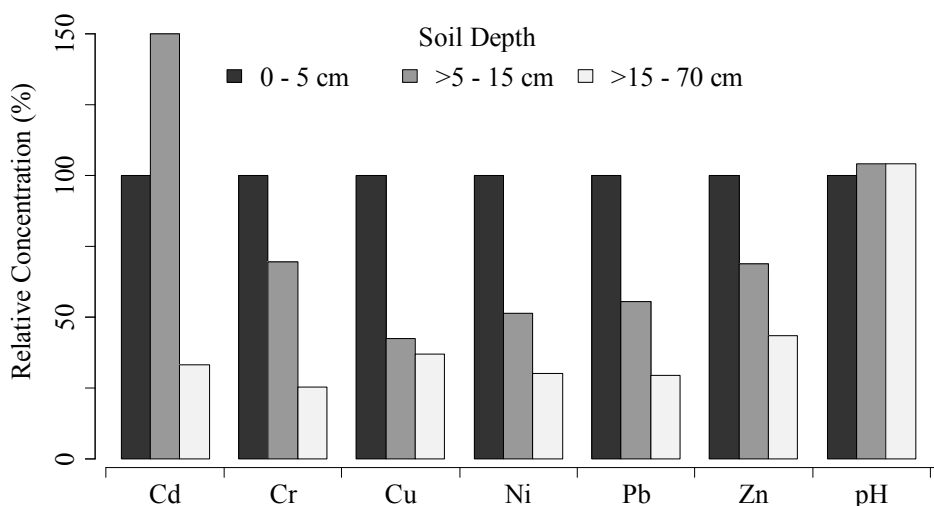

Fig. 2.6: Median soil pH and metal concentrations at >5–15 cm and >15–70 cm soil depth relative to the concentrations at 0–5 cm.

The different vertical concentration patterns were explained by site specific characteristics e.g. soil type, road operation time, vegetation, inclination of the embankment, rain intensity and the amount of road runoff. Soil pH barely changed with increasing soil depth (Boivin et al., 2008). 100% of the compiled studies had a decrease of Cd, Cu and Zn when comparing concentrations of <15 cm and topsoil concentrations. For the elements Cr, Ni and Pb a vertical decline in soil concentrations occurred in 72%, 71% and 91% of the studies. This result underlines that sorption capacity of most roadside soils is effective concerning metal retention.

### Correlation analysis

The Pearson correlation between metal concentrations in roadside soils, distance from the road and soil depth was determined. Soil pH and all metals but Cr are correlated inversely with road distance (Tab. 2.2). A high negative correlation occurred for Ni, Zn and pH. Soil depth correlated highly negatively with Cu, Pb and Zn and moderately negatively with Cd. There is no significant correlation between soil depth and Cr and Ni. This result is in line with the findings of Carlosena et al. (1998) who reported that the variation in Ni and Cr concentrations are linked strongly to natural soil variability and therefore mask pollution trends. A very high correlation occurred between soil depth and LOI. Possible reasons for negative correlations between soil metal concentrations, distance from the road and soil depth are discussed in section 2.3.1.

Tab. 2.2: Pearson correlation coefficients between a) trace element concentrations ( $\text{mg kg}^{-1}$ ) at soil depth 5 cm, pH (-), LOI (%) and distance (m) and b) trace element concentrations ( $\text{mg kg}^{-1}$ ) at road distance < 5 m, pH (-), LOI (%) and depth (cm). Bold type indicates a statistical significant correlation.

	pH	LOI	Cd	Cr	Cu	Ni	Pb	Zn
distance (a)	<b>-0.32**</b>	0.04	<b>-0.22*</b>	-0.16	<b>-0.23*</b>	<b>-0.31**</b>	<b>-0.21*</b>	<b>-0.24**</b>
depth (b)	0.13	<b>-0.60***</b>	<b>-0.33*</b>	0.07	<b>-0.33**</b>	-0.17	<b>-0.38**</b>	<b>-0.33**</b>

\* P 0.05, statistical significance of the correlations

\*\* P 0.01, strong statistical significance of the correlations

\*\*\* P 0.001, very strong statistical significance of the correlations

The correlation between traffic intensity and metal concentration is a controversial and frequently discussed issue. We found that AADT correlates very strongly with Cd and Cr concentrations, strongly with Ni concentrations and moderately with Cu and Zn concentrations (Tab. 2.3). This result corresponds to the findings of Ward (1990) and Arslan and Gizir (2006), who determined a correlation between traffic intensity and trace element concentrations in roadside soils. Perez et al. (2008) however could not find a correlation between traffic intensity and metal concentrations in roadside soil. Different traffic-induced factors that are not associated directly with traffic intensity contribute to contamination of roadside soils.

Important factors are for example, acceleration processes (Hjortenkrans et al., 2006) road maintenance, accidents (Perez et al., 2008), stop-and-go traffic (Warren and Birch, 1987), road construction devices and the use of contaminated material for embankment construction (Dierkes and Geiger, 1999).

Pb is the only metal investigated that shows no significant correlation to AADT in this study. This result is surprising because Pb was the first metal associated with intensive road traffic. Although emissions have been reduced through regulation in many European countries (Hagner, 2000), Pb still is confirmed as the most characteristic metal in roadside soils (Pleniscar and Zupancic, 2005). A reason for the missing correlation of Pb and AADT could be the composition of the data. The studies were performed over a large time period, including data collected before and after the ban of Pb in gasoline. Furthermore, the limitation on Pb varies among the different countries (Kummer et al., 2009). This restriction could lead to very heterogeneous Pb contamination levels in soils along roads that have similar traffic intensities.

In Tab. 2.3 one can see that only a moderately positive correlation between soil pH and Pb concentration can be determined. This is similar to the results of Kluge and Wessolek (2012) who could not find any correlation of pH and trace element concentrations.

Tab. 2.3: Pearson correlation coefficients and the corresponding scatter plots for soil trace element concentrations ( $\text{mg kg}^{-1}$ ) at soil depth 5 cm and road distance <5 m, pH (-), LOI (%) and AADT (vehicles day<sup>-1</sup>). Bold type indicates a statistical significant correlation.

	pH	LOI	Cd	Cr	Cu	Ni	Pb	Zn	AADT
pH									
LOI	-0.13								
Cd	-0.25	0.01							
Cr	-0.26	<b>0.44*</b>	<b>0.54**</b>						
Cu	0.28	0.01	0.28	-0.04					
Ni	-0.35	0.07	<b>0.68***</b>	<b>0.83***</b>	0.09				
Pb	<b>0.32*</b>	0.18	0.26	0.11	<b>0.62***</b>	0.15			
Zn	0.16	0.13	<b>0.36*</b>	0.21	<b>0.49***</b>	0.32	<b>0.69***</b>		
AADT	-0.30	-0.08	<b>0.61***</b>	<b>0.62***</b>	<b>0.39*</b>	<b>0.58**</b>	0.11	<b>0.30*</b>	

\* P = 0.05, statistical significance of the correlations

\*\* P = 0.01, strong statistical significance of the correlations

\*\*\* P = 0.001, very strong statistical significance of the correlations

Nonetheless soil pH is correlated to the mobility of metals in roadside soils, especially to Cd, Cu Zn (Bäckström et al., 2004). Between LOI and Cr content a moderately positive correlation was determined. While Hjortenkrans et al. (2008) found a positive correlation of LOI and all metals, Kluge and Wessolek (2012) could identify a correlation only between LOI and Cd concentration in roadside soils.

The correlation between the metals varies from none to very strong. It is well documented that a positive correlation exists between Ni and Cr (Carlosena et al., 1998; Christoforidis and Stamatis, 2009), a result which is confirmed by this study (Tab. 2.3). One reason might be the strong relationship between natural Ni and Cr in soils (Garcia et al., 1996). The strong positive correlation between Zn and Pb concentrations and the positive correlation between Zn and Cd concentrations also was reported by Kluge and Wessolek (2012). The positive correlation between Zn and Cd was appointed to the strong geochemical association and coexistence in galvanised crash barriers.

Between Cu and Pb a strong positive correlation could be determined, which also was reported by e.g. Christoforidis and Stamatis (2009). Kluge and Wessolek (2012) however could not find any significant correlation between Cu and Pb. The emissions of Cu and Zn are related to decelerating activities (Hjortenkrans et al., 2006). This relationship could be a reason for the very strong correlation that we found between these two elements, a result that was also detected by e.g. Turer et al. (2001).

Bakirdere and Yaman (2008) were the only other authors who also could determine a significant positive correlation between Cd and Cr whereas several other authors could not determine any correlation (e.g. Hääl et al., 2004; Hjortenkrans et al., 2006; Christoforidis and Stamatis, 2009).

### 2.3.2. Metals in soil solution

In Europe only a few authors have successfully analysed and published metal concentrations of soil solution in roadside soils (Reinirkens, 1996; Dierkes and Geiger, 1999; Bäckström et al., 2004; Kocher et al., 2005; Kluge and Wessolek, 2012), whereas others had problems collecting soil solution as described for example in the final report of the EU POLMIT project (POLMIT, 2002). To our knowledge Kocher et al. (2005) and Kluge and Wessolek (2012) were the only authors who determined contamination patterns of the soil solution in road-adjacent soils. For the evaluation of the collected data a distinction was made between highway (HW) sites (AADT 50,000–120,000) and main road (MR) sites (AADT 7000–20,000).

Fig. 2.7 and 2.8 display the median metal concentrations, pH and EC of soil solution at 50-cm soil depth at different distances from the roadside. Different depths were not taken into consideration because of the limited data. Median trace element concentrations of the highway sites are higher than at the main road sites for all distances, except Cr at 5 m. Nonetheless, the overall trend of metal concentrations with increasing distance is similar for highways and main roads except for highway Cu levels. Highway samples however, show a considerably larger variation for the particular metals.

#### Influence of distance

**Distance 1 m:** An explanation for the low concentrations at 1 m in contrast to 2.5 m distance, except for Cr at the HW sites with  $4.6 \mu\text{g L}^{-1}$ , could be the high infiltration rates in this zone (Kocher et al., 2005). This in turn leads to a dilution of the metals in the soil solution and additionally provides a fast transport of the soluble elements to deeper soil layers. Moreover the soil pH is elevated in this zone, lowering the solubility of metals (Bäckström et al., 2004). This assumption is supported by the fact that Cd, being the most mobile of the elements analysed, shows the lowest concentration at 1 m distance ( $0.18 \mu\text{g L}^{-1}$  HW and  $0.07 \mu\text{g L}^{-1}$  MR).

**Distance 2.5 m:** At 2.5 m the amount of road runoff infiltrating in this zone is significantly lower than at 1 m distance but considerable amounts of metals are transported to this zone by aerial transport and splashing water (Steiner et al., 2007). This combination could lead to high trace element concentrations in soil solution at 2.5 m. At the Highway sites Cu and Pb have the highest concentrations ( $59.7 \mu\text{g L}^{-1}$  and  $2.34 \mu\text{g L}^{-1}$ ) at 2.5 m distance.

**Distance 5 m:** The ditches of the highway sites investigated are mostly located at a distance of 5 m. In contrast to 1 m distance, runoff water only infiltrates during intensive rainfall leading to a dilution of metal concentrations in runoff and percolation water. This trend was also found by Kluge and Wessolek (2012) who explained these findings with slightly higher pH and lower EC values at a distance of 5 m compared to 1 and 2.5 m distance.

At the major road sites the decrease in trace element concentrations is not strong, Cu and Zn concentrations even increase slightly at 5 m distance compared to 2.5 m. This contrast between major roads and highways may be due to the different methods of road construction and the morphology of the immediate environment (elevated position, embankment and slope, ditches at highway sites) which leads to different patterns of road runoff infiltration.

**Distance 10 m:** At 10 m distance to the road edge all trace element concentrations increase compared to 5 m at highway and major road sites except for Cu. For the highway sites Cd ( $0.7 \mu\text{g L}^{-1}$ ), Ni ( $9.1 \mu\text{g L}^{-1}$ ) and Zn ( $213 \mu\text{g L}^{-1}$ ) reach maximum concentrations at this distance, for the major road sites all trace elements have maximum concentrations (Cd  $0.15 \mu\text{g L}^{-1}$ , Cr  $2.65 \mu\text{g L}^{-1}$ , Cu  $9.9 \mu\text{g L}^{-1}$ , Ni  $5.25 \mu\text{g L}^{-1}$ , Pb  $0.82 \mu\text{g L}^{-1}$  and Zn  $38.5 \mu\text{g L}^{-1}$ ). Pollutants only reach this zone by aerial transport; road runoff and splashing water are no longer relevant (Golwer, 1991; Steiner et al., 2007). Lower pH and EC values and the reduced amount of infiltration water at 10 m distance compared to 5 m may lead to increasing soil solution concentrations at 10 m distance.

Overall the concentrations of metals in soil solution near highways and main roads vary greatly. However the investigations showed that the German trigger values for soil solution concentration (BBodSchV: Cd 5, Cr 50, Cu 50, Ni 50, Pb 20 and Zn  $500 \mu\text{g L}^{-1}$ ) are only sporadically exceeded (see supplementary material for more details, Tab. S2). Median Cu concentration at two metre distance is the only one exceeding the German trigger value. European threshold values for drinking water (Directive, EC Council: Cd 5, Cr 50, Cu 2000, Ni 20 and Pb  $10 \mu\text{g L}^{-1}$ . Zn has no limitations) are not exceeded by the median metal concentrations in soil solution.

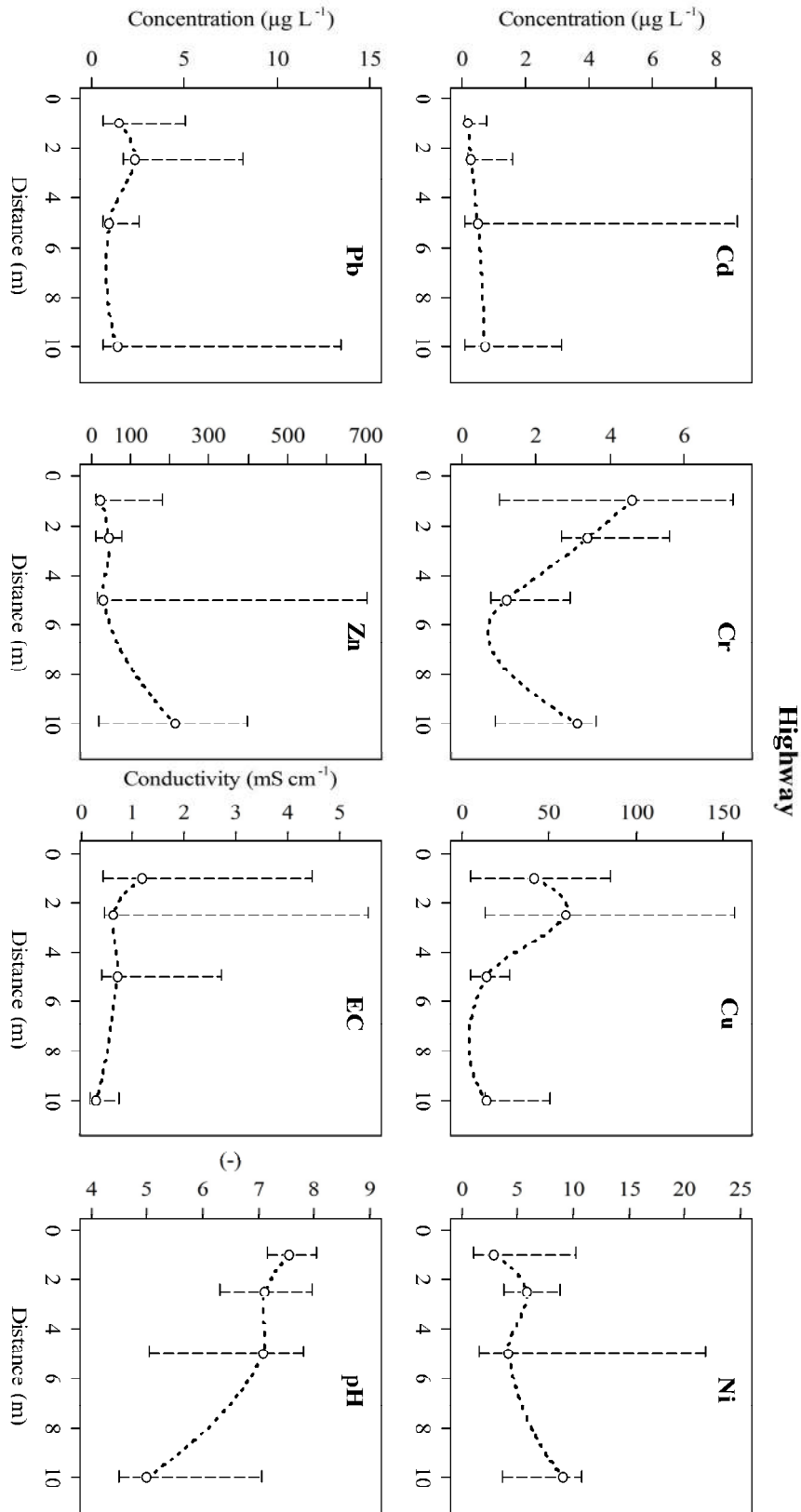

Fig. 2.7: Median pH, EC and metal concentration of soil solution at 50-cm depth at highway sites (AADT 50,000-120,000) as a function of distance from the road edge. Bars indicate minimum and maximum concentrations.

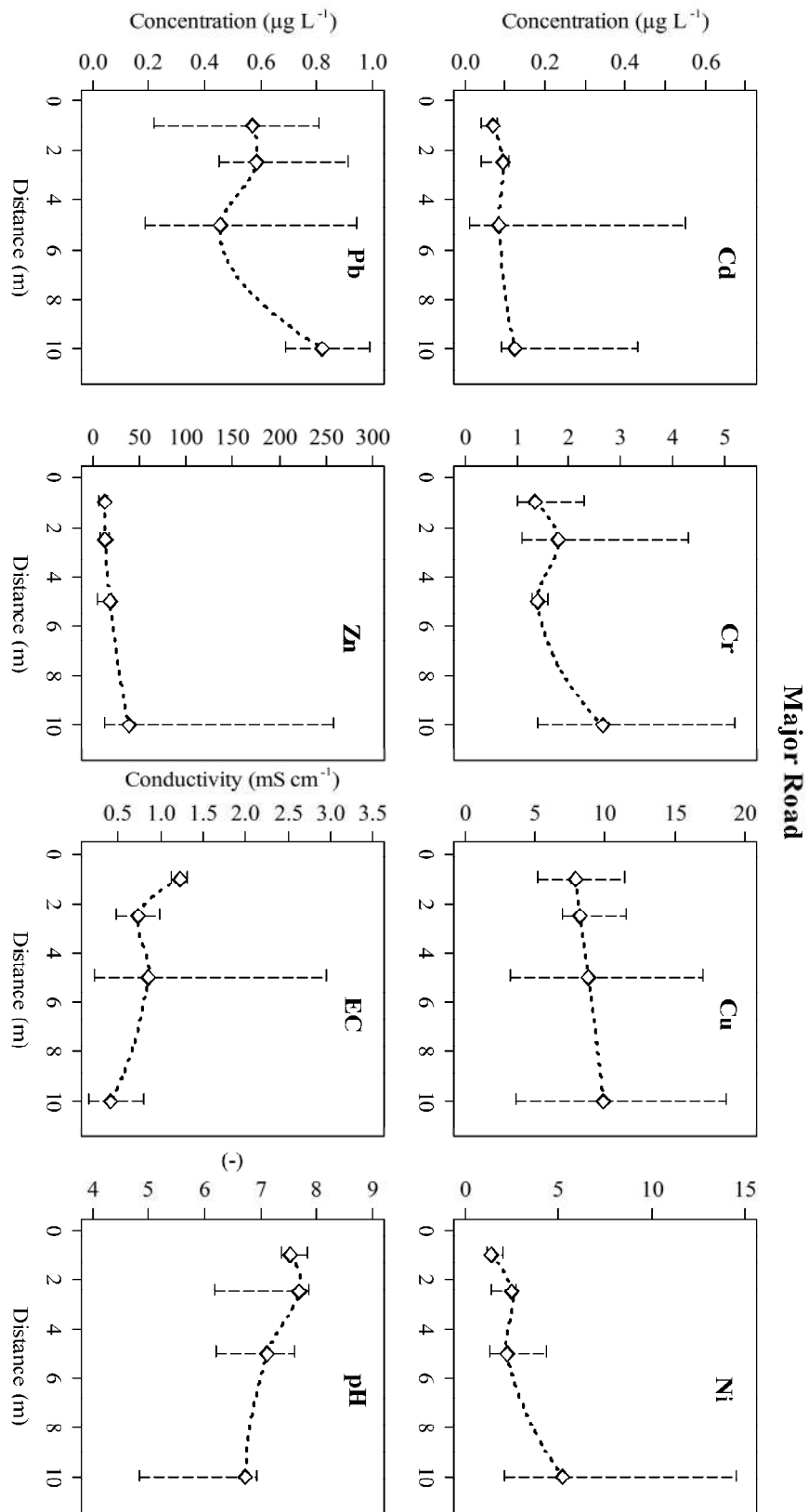

Fig. 2.8: Median pH, EC and metal concentration of soil solution at major road sites (AADT 7000-20,000) as a function of distance from the road edge. Bars indicate minimum and maximum concentrations.

The general trend in soil solution concentrations can be described approximately as follows: at 1 m distance trace element concentrations are elevated and continue to increase at 2.5 m (compared to 1 m), at 5 m the concentrations decrease (compared to 2.5 m) and then increase again at a distance of 10 m (compared to 5 m). This is only a rough estimation and the real concentration patterns may differ at certain points as can be seen in Fig. 2.7 & 2.8. This illustrates that metal concentration patterns in soil solution show a different trend than concentrations of the soil matrix.

### Correlation analysis

The Pearson correlation coefficients of AADT, soil solution concentrations of metals, pH and EC are displayed in Table 2.4. For the correlation analysis sampling data of the zone 1–5 m distance from the road edge and sampling depth 50 cm were evaluated. The Cu and Pb concentrations are correlated very strongly and positively with AADT whereas Cr and Ni concentrations are strongly correlated with AADT. All trace element concentrations correlate positively among each other to a greater or lesser degree. A strong negative correlation between pH with Ni and a very strong negative correlation between pH with Zn and Cd concentrations was determined, whereas EC is strongly positive correlated with pH. The Cr, Cu and Pb concentrations do not correlate statistically significantly with pH, but concentrations of Cu and Cr correlate with EC. The authors explained the correlation between Cu and EC by high ion exchange rates (Bäckström et al., 2004) and by increased mobilisation of DOC leading to higher Cu concentrations (Koehler et al. 2005).

Tab. 2.4: Pearson correlation coefficients between trace element concentrations in soil solution (depth 50 cm, road distance <5 m), pH, EC and AADT. Bold type indicates a statistical significant correlation.

	pH	EC	Cd	Cr	Cu	Ni	Pb	Zn	AADT
pH	-								
EC	<b>0.45**</b>	-							
Cd	<b>-0.48***</b>	0.00	-						
Cr	-0.14	<b>0.36*</b>	<b>0.31*</b>	-					
Cu	0.13	<b>0.39**</b>	<b>0.33*</b>	<b>0.71***</b>	-				
Ni	<b>-0.41**</b>	0.05	<b>0.80***</b>	<b>0.58***</b>	<b>0.64***</b>	-			
Pb	-0.23	0.00	<b>0.49*</b>	<b>0.56***</b>	<b>0.67***</b>	<b>0.70***</b>	-		
Zn	<b>-0.60***</b>	-0.14	<b>0.90***</b>	<b>0.47**</b>	<b>0.41**</b>	<b>0.86***</b>	<b>0.66***</b>	-	
AADT	-0.12	0.20	<b>0.32*</b>	<b>0.42**</b>	<b>0.63***</b>	<b>0.47**</b>	<b>0.48***</b>	<b>0.37*</b>	-

\*  $P < 0.05$ , statistical significance of the correlations

\*\*  $P < 0.01$ , strong statistical significance of the correlations

\*\*\*  $P < 0.001$ , very strong statistical significance of the correlations



## Loading

On the basis of the above results and the findings of Kocher et al. (2005) who estimated the percolation rates in roadside soils, one can deduce the following relationships between soil solution concentration, percolation rate and loadings as a function of distance to the road edge (Fig. 2.9). The annual leaching rates (Fig. 2.9, bottom) were estimated using the mean annual percolation rates (Fig. 2.9, top) multiplied by the average Cd and Ni concentrations (Fig. 2.9, middle) of the soil solution at 1 m depth (Kocher et al., 2005 and Kluge and Wessolek, 2012). The concentrations of Cd and Ni were derived from the data shown in Figure 2.7. Due to high pH values and high infiltration rates close to the road (0–2 m), only low Cd and Ni concentrations are to be found at this distance. The high infiltration rates lead to high leaching rates. In contrast, a low pH value and percolation rates that are not influenced by runoff and splash water induces high solute concentrations at distances >8 m from the road (Wessolek et al., 2011). However, the leaching rates at this distance are much lower than to the one close to the road.

## 2.4. Conclusion

This review shows that road construction and traffic are affecting the surrounding roadside soils significantly. The accumulation of metals and their transfer to groundwater constitutes a potential long-term risks for the environment. Despite the large variation of study site conditions, the synthesis of data shows some typical patterns and results: Trace element concentrations in the topsoil layer (0–<5 cm) of the first 5 m besides the road are influenced strongly by road traffic-induced emissions. Median concentrations of all metals exceed the background concentrations. Generally the influence of road traffic on soil contamination decreases with increasing soil depth or distance from the road. Traffic intensity is correlated positively with trace element concentrations except for Pb, which might be a result of eliminating additions of Pb to gasoline. Soil pH has a great influence on Pb retention, whereas soil organic matter has greater influence on immobilising Cr. Solute concentrations often increase within a distance up to 10 m. At this distance, elevated solute concentrations often occur because of low pH and low percolation rates which are only scarcely affected by road runoff or splashing water at this distance. However, trace element concentrations exceeding the German trigger values were observed only sporadically. Low soil solution concentrations directly at the road edge underline that sorption capacity of roadside soils is high, mostly owing to high pH and dust input.

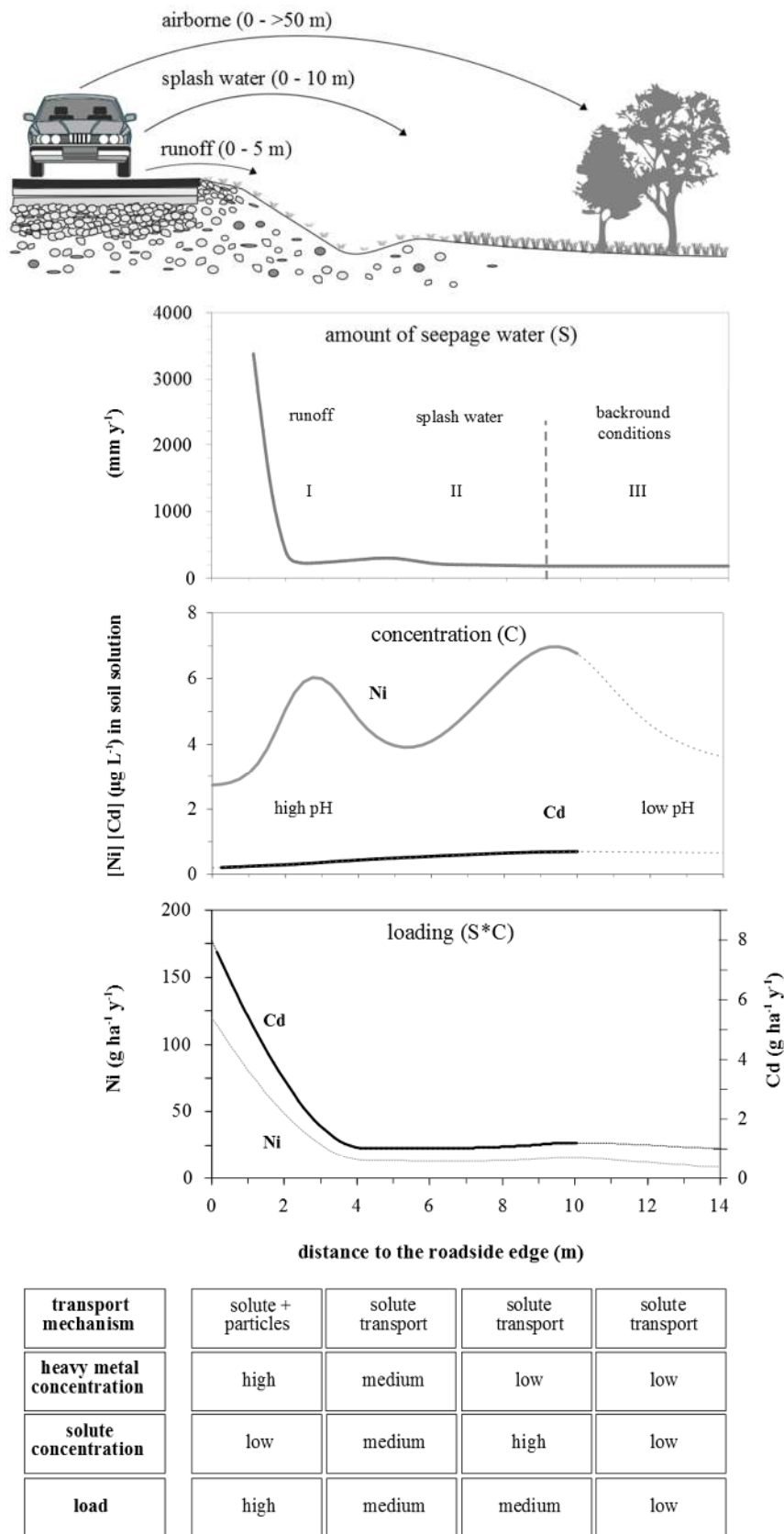

Fig. 2.9: Schematic illustration of the mean annual percolation rate (top), mean cadmium and Ni concentration in soil solution at 0.5 m depth (middle) and annual leaching rates (bottom) on a highway roadside as a function of distance based on data of Kocher et al. (2005) and Kluge and Wessolek (2012).

In terms of a risk assessment this could be of relevance at newly constructed highway sites whereas older sites will typically have high pH, soil organic matter and dust accumulation. High percolation rates occur only at the immediate road edge leading to high loads of trace elements. These loads might be problematic in regions with acidic sandy soils and a high groundwater table. Even though metal concentrations in percolation water are of central importance for groundwater quality, only five studies dealt with this topic. In order to estimate the risk of groundwater pollution, regular monitoring of soil solution quality on such a site is recommended highly. Secondly, the role of particle transport and preferential flow have not yet been investigated sufficiently.

### **Acknowledgement**

We would like to thank Dr. B. Kocher of the Federal Highway Research Institute, Germany, for providing data.

### 3. Metal leaching in a highway embankment on field and laboratory scale<sup>2</sup>

Björn Kluge, Moritz Werkenthin, Gerd Wessolek  
Department of Ecology, Soil Conservation, Technische Universität Berlin  
Ernst-Reuter Platz 1, 10587 Berlin, Germany

Contact: bjoern.kluge@tu-berlin.de; moritz.werkenthin@tu-berlin.de; gerd.wessolek@tu-berlin.de

#### **Abstract:**

Increasing worldwide motor vehicle traffic leads to the question of the possible environmental consequences. This paper aims to analyse metal leaching in a highway embankment using both field and laboratory experiments. Soil, soil solution and road runoff were collected along one of the oldest highways in the world to characterize leaching of the metals Cd, Cr, Cu, Ni, Pb and Zn. Batch, column and adsorption experiments were carried out to study the reliability and transferability of laboratory approaches. Depending on the element, the ratio of particle-bound metals in road runoff varied between 15-90 %. Metal levels in embankment soils were significantly higher compared to a reference site in a forest at 800 m distance (up a factor of 30). High metal concentrations in soil solution at 50 cm soil depth were not a direct result of road runoff but rather of elevated concentrations in the soil matrix. The use of batch S4 elution was found to be the best overall laboratory method to predict soil solution concentrations in field. Adsorption experiments showed a relative increase in retention capacity in roadside soil of up to a factor of 20 after nearly 100 years of operation. The input of alkaline dust and organic carbon into roadside soils increases its retention capacity in the long term.

#### **Keywords:**

Roadside soil; Heavy metals; Soil solution; Particle transport; Highway; Retention

---

2 Published: Kluge, B; Werkenthin, M and Wessolek, G. Science of the total Environment (2014): 493, 495-504.

### 3.1. Introduction

Highways and intensively trafficked roads are major sources for pollutants introduced into the environment. The growing volume of worldwide traffic leads to increasing emission rates causing a contamination of roadside soils (Monks et al., 2009). Emissions from traffic contain a complex mixture of pollutants such as carbon monoxide, nitrogen oxide, hydrocarbon and sulphur dioxide, polycyclic aromatic hydrocarbons and metals which can occur in particulate and dissolved form (Westerholm and Egebäck, 1994; Zehetener et al., 2009). The traffic-derived pollutants originate from a variety of sources including incomplete and complete fuel combustion, fuel losses and oil leakage from hydraulic systems. Corrosion, de-icing activities and vehicle component wear and tear (tires, brakes, clutch and engine) are also important sources of traffic emissions (Hjortenkrans et al., 2007; McKenzie et al., 2009). Another relevant pollutant source is the dust resulting from the abrasion of the road construction material itself (Lindgren, 1996; Thorpe and Harrison, 2008). Folkeson et al. (2009) classified the pollution sources of road traffic into the following five groups: traffic and cargo, pavement and embankment material, road equipment, maintenance and operation and external sources.

Most pollutants are emitted in gaseous form or as fine particles which deposit directly on the roadway and/or the surrounding vegetation and soils. The composition and amount of dry and wet deposition depends on many factors, such as traffic intensity (Ward, 1990; Arslan and Gizir, 2006), wind direction, wind velocity, rain events and intensity, previous dry periods, highway design or vegetation cover (Barbosa and Hvitved-Jacobsen, 1999; Pagotto et al., 2001; Lee et al., 2011). The road design plays a decisive role in the level and the dispersion of soil pollution. Depending on road construction and inclination of the embankment, spray water and road runoff can be transported up to a distance of 10 m (Golwer, 1991; Kocher et al., 2005). According to Steiner et al. (2007) wind and airflow may carry fine dust particles up to a distance of 25 m, whereas Zechmeister et al. (2005) measured fine particle transport at a distance of 250 m. Golwer (1991) defined three different loading areas for roadside environments:

- (I) 0-2 m: dominated by runoff and splashing water
- (II) 2-10 m: splashing water and partly runoff depending on inclination
- (III) 0-100 m, covered by the influence of airflow and wind

Metals are the pollutants of greatest concern because of their long-term toxicity for microorganisms, plants, animals and humans. Among others, Cd, Cr, Cu, Pb, Ni and Zn are the most widely recognized and examined metals in roadside environments (Münch, 1993; Folkeson et al., 2009; Kayhanian et al., 2012).

The infiltration of road runoff as well as dust deposition leads to elevated metal concentrations in soils adjacent to the road. Furthermore, the leaching of galvanised crash barriers and road signs by rain and splashing water releases a considerable amount of metals (Van Bohemen and Van de Laak, 2003). Soil metal contamination typically decreases with increasing soil depth and distance to the road edge (e.g. Harrison et al., 1985; Pagotto et al., 2001; Carrero et al., 2013; Modrzewska and Wyszowski, 2014). Roadside soils often significantly change their original physical, biological and chemical properties due to road construction and maintenance. The most important influencing factors are the rearrangement of the topsoil layer in the course of road construction, the deposition of traffic-derived sediments on the embankment and the elevated infiltration of road runoff (Pouyat et al., 2007; Kluge and Wessolek, 2012).

The mobility of metals in roadside soils is strongly influenced by soil pH and organic matter as several authors pointed out (Turer and Maynard, 2003; Walraven et al., 2014; Werkenthin et al., 2014). Turer and Maynard (2003) found a strong positive correlation between soil organic matter and certain metal concentrations. The easily exchangeable metal fraction could be mobilised if soils are subjected to extreme weather conditions like dry periods (oxidation) or long intensive rain periods (reducing condition) (Hjortenkrans et al., 2008). The use of de-icing agents for road maintenance promotes a high dispersion and leaching of organic matter in roadside soils. This in turn leads to increased metal mobilization in roadside soils (Bäckström et al., 2004; Ramakrishna and Viraraghavan, 2005). The long-term accumulation of metals in roadside soils may lead to high concentrations in seepage water. This could result in groundwater pollution or contamination of receiving waters with negative effects for surrounding water catchments. Therefore roadside soils play an important role in (ground-) water protection.

One possibility to estimate this risk is to perform laboratory leaching studies on highway soils. Indeed, this has been carried out with increasing frequency in recent years (e.g. Barbosa and Hvitved-Jacobsen, 1999; Hjortenkrans et al., 2007; Saeedi et al., 2009). Another possibility is to determine the soil solution concentrations on-site next to the affected roads and highways (Reinirkens, 1996; Dierkes and Geiger, 1999; Bäckström et al., 2004; Kocher et al. 2005; Kluge and Wessolek, 2012). To our knowledge no comparative study of laboratory and field measurements on metals leaching in roadside soils exists. Although it is well documented that certain metals in road runoff are, to a large extent, bound to particles (Legret and Pagotto, 1999; Helmreich et al., 2010), only Roulier et al. (2008) performed a field measurement on preferential particle-bound Pb transport in roadside soils. They could show that the proportion of particle-bound Pb in soil solution reached up to 85% of total metal concentration. Recent laboratory studies (Blecken et al., 2011) on stormwater infiltration indicate that also significant proportions of particle-bound Zn, Cu and Cd are transported vertically via soil solution.

Therefore the objective of this study was to measure dissolved and particle-bound metal concentrations (Cd, Cr, Cu, Ni, Pb and Zn) in road runoff, roadside soil and soil solution along the AVUS Autobahn, one of the oldest highways in the world, in order to determine the leaching characteristics of roadside soils. Another aim was to evaluate the reliability and transferability of different laboratory experiments to field measurements. Adsorption experiments were carried out with a sample of embankment soil and a soil considered as a reference soil in this study to determine the change of retardation capacity after a long-term highway operation.

## 3.2. Material and methods

### 3.2.1. Study site

The AVUS highway is located in the southwest of the capital Berlin; Germany ( $52^{\circ} 28' 43.8''$  N,  $13^{\circ} 14' 54.69''$  E) and connects the express highway A100 of the inner ring with the outer Berliner Ring highway A 10 (Fig. 3.1). The study site was part of the old AVUS racetrack, opened in 1921 and considered to be the oldest highway in the world (Bayliss, 1990). The AVUS has three asphalt lanes per direction with a width of 4 m per lane with an annual average daily traffic (AADT) of 90.000-100.000 vehicles per day.

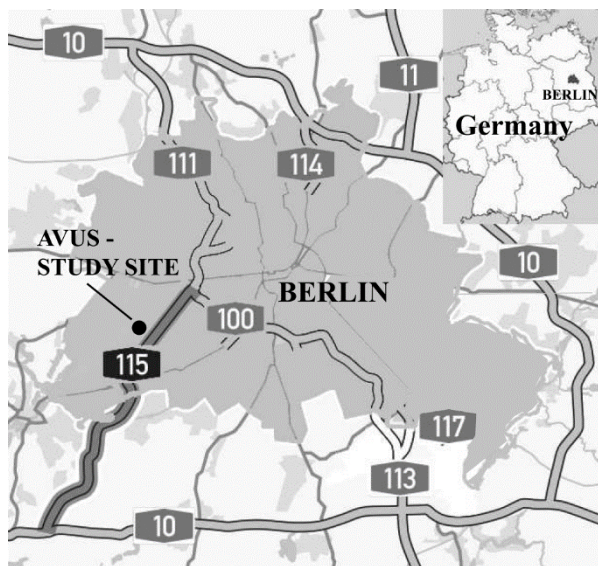

Fig. 3.1: Location of the study site-AVUS A115, Berlin, Germany

At the study site the AVUS highway is surrounded by a mixed pine-oak forest at a distance of about 15 m from the road. The soils in the surrounding area of the AVUS highway are Spodo-Dystric Cambisols (FAO 2006).

According to the environmental agency of the State of Brandenburg, mean background concentrations of Cd, Cr, Cu, Ni, Pb and Zn are 0.15, 2.2, 10, 0.8, 22 and 16 mg kg<sup>-1</sup> respectively (LABO, 2003). Annual average temperature is 8°C and precipitation is 580 mm.

### 3.2.2. Sampling in field

#### Soil

Samples of embankment soils (T=transect) were collected along a transect of 25 m x 10 m at three different distances from the road (2.5 m, 5 m and 7.5 m). A stainless steel shovel was used to collect the top 0-25 cm soil layer at every meter. Soil horizons from 0-10 and 10-25 cm were sampled at least at five locations and mixed to one representative sample of about 3 kg. The reference samples were taken in a forest at 800 m distance to the road. Before chemical analysis, all soil samples were mixed again, air-dried and sieved through <2 mm. A sample of about 400 kg of embankment soil was collected near the roadside gateway Hüttenweg (52° 27 47.6 N, 13° 15 36.63 E) at a distance of 7.5-10 m to the edge of the AVUS (0-25 cm) as a representative embankment soil (B=batch) for all batch leaching experiments. The soil sample was air dried and sieved through <5 mm in order to remove coarse material from the litter layer (O-Horizon) as well as to ensure a good comparability between batch leaching experiments and field measurements.

#### Soil solution

To collect soil solutions, a monitoring site was equipped with a total of 90 suction cups (Fa. Haldewanger, SKA100 FF-pore diameter 0.45 µm) at three different depths (10, 30 and 50 cm) and distances (2.5, 7.5 and 10 m). The suction cup method is used especially for long-term monitoring of soil water concentrations (Grossmann and Udluft, 1991). The sampling period was from December 2007 to December 2008. Further information about the installed suction cup monitoring field is described by Kluge and Wessolek (2012).

To determine dissolved and particle-bound metal concentrations in soil solution, three self-constructed wick lysimeter were installed at 2.5 m distance from the roadside. The wick lysimeter consisted of a square box made of PE with dimensions measuring 25 cm x 25 cm. At the bottom of the box, wick fingers (Pepperell Company, USA) were placed in a gravel bed. The wick lysimeter boxes were installed at three roadside profiles at 50 cm soil depth. Soil solution was gained by the wicks using a hanging water column of 63 cm (=field capacity) and transported via the wick to a sampling bottle (Fig. 3.2). The collected sample was divided into two equal parts.



One part of the composite sample was filtered through a  $0.2\ \mu\text{m}$  filter while the other part was vaporized and the solid residue digested to separately determine dissolved ( $<0.2\ \mu\text{m}$ ) and particle-bound metals ( $>0.2\ \mu\text{m}$ ). The sampling period was from January to March 2008.

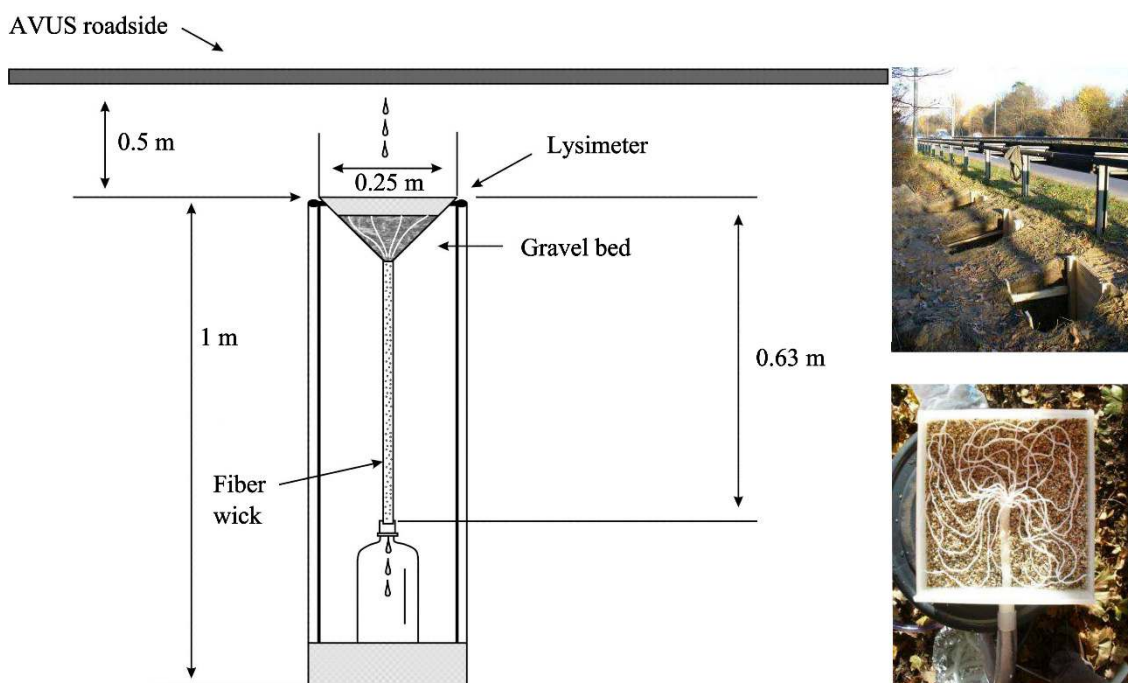

Fig. 3.2: Schematic sketch of a wick lysimeter setup (left side) and pictures of the monitoring site (top) and a wick lysimeter (bottom).

### Run-off

Two runoff samplers were installed directly at the road edge, one at the beginning and one at the end of the wick lysimeter site to measure metal concentration in AVUS runoff. The samplers are made of PE (75 cm x 10 cm x 15 cm) and have three collection chambers. The samplers were covered with a gaze of 5 mm diameter to retain litter from sampling chambers. The runoff passed through PE tubes into three rain barrels (100 l). Composite samples were divided into two equal parts. One part of the composite sample was filtered through a  $0.2\ \mu\text{m}$  filter while the other part was vaporized and the solid residue digested to separately determine dissolved ( $<0.2\ \mu\text{m}$ ) and particle-bound metals ( $>0.2\ \mu\text{m}$ ). Samples were collected from February to March 2008.

### 3.2.3. Laboratory leaching experiments

Batch experiments were carried out to predict sorption behaviour and soil solution concentrations from the AVUS embankment soils.

### **Soil saturation extracts (Batch SSE)**

This method is part of the German Soil Protection Law (BBodSchG, 1998 and BBodSchV, 1999). It is used as a test procedure to determine the potential risk of the transfer of metals from soil to soil solution and consequently from soil to groundwater. The air dried embankment (B) and reference soil were moistened to a content of about 20 % water (v m<sup>-1</sup>) and mixed using a PE shovel. After mixing, the soil was divided into six equal parts and 250 g soil material taken from each to form one sample. All samples were placed in a fridge at 4°C for 24 h. To prepare the soil saturation extract, deionised water was added slowly under constant stirring until the flow limit was reached. In order to establish equilibrium, samples were kept at 4 °C for 24 h. To separate soil solution from soil matrix, a vacuum filtration unit (Fa. Sartorius) with a cellulose nitrate membrane filter (0.45 µm pore size) was employed. The solution was acidified with HNO<sub>3</sub> (5 mol L<sup>-1</sup>) to pH 2 and kept at 4°C before analysis.

### **S4 Elution (Batch S4)**

The metal leachability by water from the embankment soils (B) was determined according to the “German standard method for the examination of water, waste water and sludge; sludge and sediments (group S); determination of leachability by water (S 4)” (DIN 38414-4, 1984). This method is well established and widely used in Germany and other countries (Schuwirth and Hofmann, 2006; Delay et al., 2007; Rennert and Ringlebe, 2010; Eche-garay et al., 2013). Deionised water was added to the soil samples in a ratio of 1:10. Afterwards, the samples were treated in an overhead shaker with 10 rpm for 24 h and subsequently filtered through a 0.45 µm filter and analysed.

### **Soil column experiments**

Soil column experiments were carried out with four PE columns (height = 30 cm; diameter 8 cm) based on the method DIN V 19736 (Enell et al., 2004; Gamst et al., 2007). All columns were filled with roadside embankment soil (B). Irrigation was realized via sprinkler heads with injection needles. The irrigation rate was set to 1.3 mm h<sup>-1</sup> for 15 h. Another round of irrigation was started after 48 h in order to establish equilibrium conditions between soil matrix and pore water. Chemical composition of the irrigation water was simulated according to data provided by the environment agency of the state Brandenburg. The following ion concentrations (µmol L<sup>-1</sup>) were established: NH<sub>4</sub><sup>+</sup> 69.4, Na<sup>+</sup> 24.1, Ca<sup>2+</sup> 10.5, Mg<sup>2+</sup> 3.9, K<sup>+</sup> 3.0, Cl<sup>-</sup> 20.9, SO<sub>2</sub><sup>-</sup> 28.3 and NO<sub>3</sub><sup>-</sup> 50.9. Over a total period of 3 months, all columns were irrigated with a water amount of 240 mm, which corresponds to approximately six pore volumes. After every pore volume that percolated through the columns, soil solution samples were filtered through a 0.45 µm filter and subsequently analysed.

### Adsorption experiments (AI)

Adsorption experiments with four levels of metal additions were applied in order to determine the adsorption isotherms. For each level, 250 g of embankment soil (B) and reference soil were spiked with a solution containing the metals listed in Table 3.1 as acetates and then saturated with H<sub>2</sub>O according to DIN V 19735 (see also section Batch SSE). The samples were then stored at 4°C for 48 h, with one stirring after 24 h. The saturation extract was obtained by means of vacuum-filtration through a 0.45 µm cellulose-acetate filter and analysed for metals. Tab. 3.1 shows the metal additions for the batch adsorption tests. Concentration levels listed in Tab. 3.1 are based on the solid/liquid ratio of the desorption (level 1) and the solubility product of the different metal carbonates.

Tab. 3.1: Metal additions (mg L<sup>-1</sup>) for the batch adsorption experiments.

Metal	Level 1	Level 2	Level 3	Level 4
Cd	0	0.3	3	6
Cu	0	15	150	300
Pb	0	25	125	250
Zn	0	30	200	400

The soil solution concentrations were used in order to calculate the adsorbed amounts of the metals. For the fitting of an adsorption isotherm to experimental data with complex solid phases like soils, the use of the Freundlich-adsorption model is widely recommended (Stumm and Morgan, 2013). The Freundlich adsorption isotherms were calculated according to equation [1].

$$S_i = K_F C_i^a \quad [1]$$

Where  $S_i$  is the concentration of the substance in the soil at adsorption equilibrium (mg kg<sup>-1</sup>);  $C_i$  is the mass concentration of the substance in the aqueous phase at adsorption equilibrium (mg L<sup>-1</sup>);  $K_F$  the Freundlich constant (l kg<sup>-1</sup>) and  $a$  the Freundlich exponent (-). The log-transformed data fitted to Freundlich-isotherms of the type.

$$\log(S_i) = \log(K_F) + a \log(C_i) \quad [2]$$

The coefficients of determination ( $R^2$ ) were always above 0.95. The adsorption characteristics are studied to describe the mobility of the metals. A good method to compare different adsorption characteristics with different degrees of linearity is to calculate the retardation factor  $R_F$ , which derives from the convection-dispersion equation and describes the retardation of substances compared to a conservative, non-sorbing tracer:

$$R_F = 1 + \frac{\rho_b}{\theta} \frac{\partial S_i}{\partial C_i} \quad [3]$$

With  $\rho_b$  [g cm<sup>-3</sup>] defined as the dry bulk density and  $\theta$  [m<sup>3</sup> m<sup>-3</sup>] defined as the water content of the soil. For non-linear adsorption of solutes described by the Freundlich model,  $R_F$  becomes:

$$R_F = 1 + \frac{\rho_b}{\theta} \frac{\partial S_i}{\partial C_i} = 1 + \frac{\rho_b}{\theta} a K_F C_i^{a-1} \quad [4]$$

### Elemental analysis

The pseudo total metal contents in soils were determined by aqua regia digestion in closed vessels in a Multiwave 3000 microwave oven (Perkin Elmer Instruments) according to DIN ISO 11466 (1997). The concentrations of Cd, Cu, Cr, Pb and Ni in the digests and in the soil solutions were measured by graphite tube atomic absorption spectrophotometer (Varian SpectrAA 800Z) and Zn concentrations by flame AAS (AAS Perkin Elmer 1100 B). Metal concentrations in the digests were determined according to DIN ISO 11047 (1998), metal concentrations soil solutions were determined according to the methods defined in the BBodSchV (1999). All samples were run in triplicates. The Kolmogorov-Smirnov test was used to test the distribution of the values for normality. Quality assurance procedures were carried out to ensure reliability of the results. Analytical grade reagents and bi-distilled water were used during all procedures. A certified quality control sample (BRM 06C, Germany) from the Federal Institute for Materials Research and Testing, Germany (BAM) was used as quality control sample. The recovery rates of the analysed metals in the certified reference material were >90% (Cd=101%; Cr=95%, Cu=98%; Pb=97%; Ni=96%; Zn=101%). Limits of quantification (LOQ) for measured metals were: Pb (0.5), Cu (1), Ni (0.5), Cr (0.5), Cd (0.2) and Zn (10) µg L<sup>-1</sup>.

## 3.3. Results and discussion

### 3.3.1. Soil properties

Some physic-chemical soil properties of the embankment soil (B) used for the batch leaching experiments are listed in Table 3.2. The embankment soil (B) shows a higher pH and CaCO<sub>3</sub> content compared to the reference site at 800 m distance. The clay content is also elevated at the embankment soil (B) compared to the reference soil.

This in turn leads to an increase of cation exchange capacity (CEC). Organic carbon (OC) at the top layer (0-25 cm) is comparable to the reference soil, but slightly lower. The texture of all analysed soils is sand. The geological conditions of the reference and the embankment soil are the same. The differences in texture and chemical properties can be explained by the input of traffic-derived particles into the embankment. Changes of chemical properties like soil pH and OC of roadside soils have been reported previously by several authors (Legret and Pagotto, 2006; Pouyat et al., 2007; Hjortenkrans et al., 2008).

Tab. 3.2: Soil properties of the different soil samples used for the batch leaching experiments.

ID	pH	OC (%)	Clay (%)	CaCO <sub>3</sub> (%)	CEC (mol L <sup>-1</sup> )
Embankment B	5.7	3.2	4.0	0.33	2.2
Reference	3.9	4.8	2.2	0.09	1.61

### 3.3.2. Road runoff

Fig. 3.3 shows the mean dissolved (<0.2 µm) and particle-bound (>0.2 µm) metal concentrations in runoff from the AVUS highway. For Cr, Ni, Cu, Zn and Pb there is a higher ratio of particle-bound to dissolved metals whereas for Cd, the dissolved fraction dominates. The proportion of dissolved Cd was about 75%, whereas it was only about 15% for Pb. Dissolved concentration of Zn accounts for about one third of the total runoff concentration; dissolved concentrations of Cr, Ni and Cu make up a little less than 30%.

Dierkes and Geiger (1999) determined a similar ratio of dissolved and particle-bound concentrations in the runoff of the A 43 highway in Germany. The dissolved concentration of Cd made up about 85% and the dissolved Pb about 10%. Legret and Pagotto (1999) determined dissolved runoff concentrations at Nantes (France). The dissolved concentration was 9% of Pb, 60% of Zn, 56% of Cu and 54% of Cd. The average runoff concentrations measured by Preciado and Li (2006) on a highway in British Columbia (Canada) are within the same range. The dissolved concentrations in runoff were 7% of Pb, 48% of Cu and 25% of Zn. Helmreich et al. (2010) measured mean values for the dissolved fraction of 27% for Zn, 21% for Cu and 17% for Ni. The Pb fraction was found to be completely particle-bound.

The high level of agreement between the proportion of dissolved and particle-bound metals in road runoff at different locations indicates, that the sources of the different metals are similar. Pb for example mainly originates from exhaust emission (particle-bound), whereas Cd and Zn originate from different sources like brake and tire wear or car body and traffic device leaching (Thorpe and Harrison, 2008).

Fig. 3.4 shows a comparison of mean total concentrations of AVUS runoff with runoff concentrations at different highway sections in Germany determined by other authors.

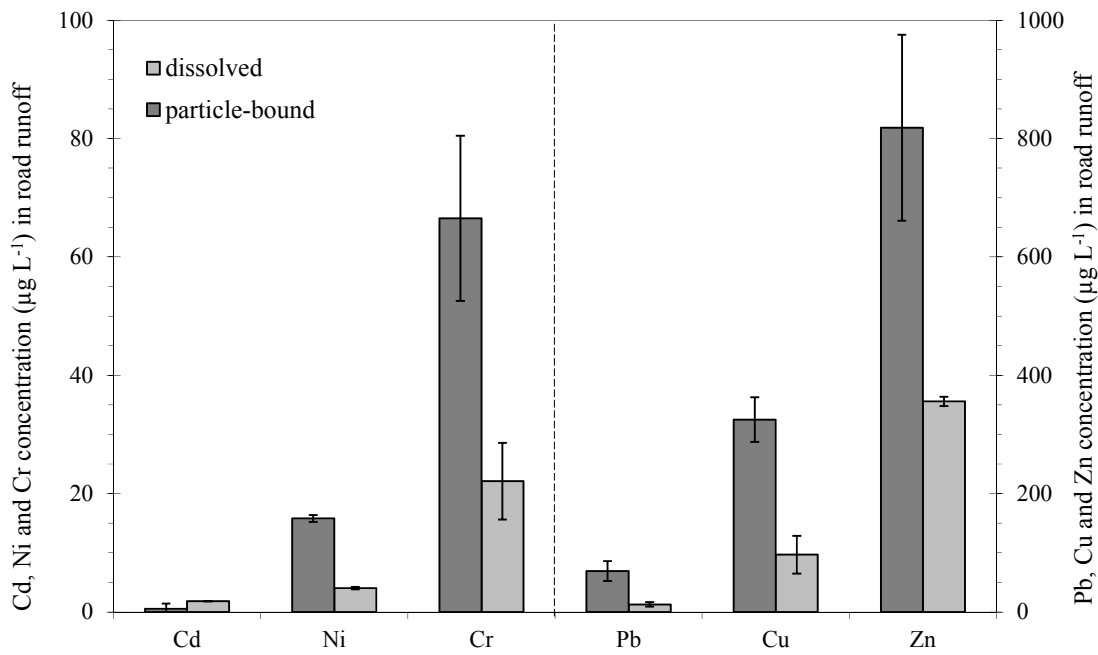

Fig. 3.3: Mean road runoff concentrations of dissolved and particle-bound metals at the AVUS highway. Dashed line separates the two different y-scales.

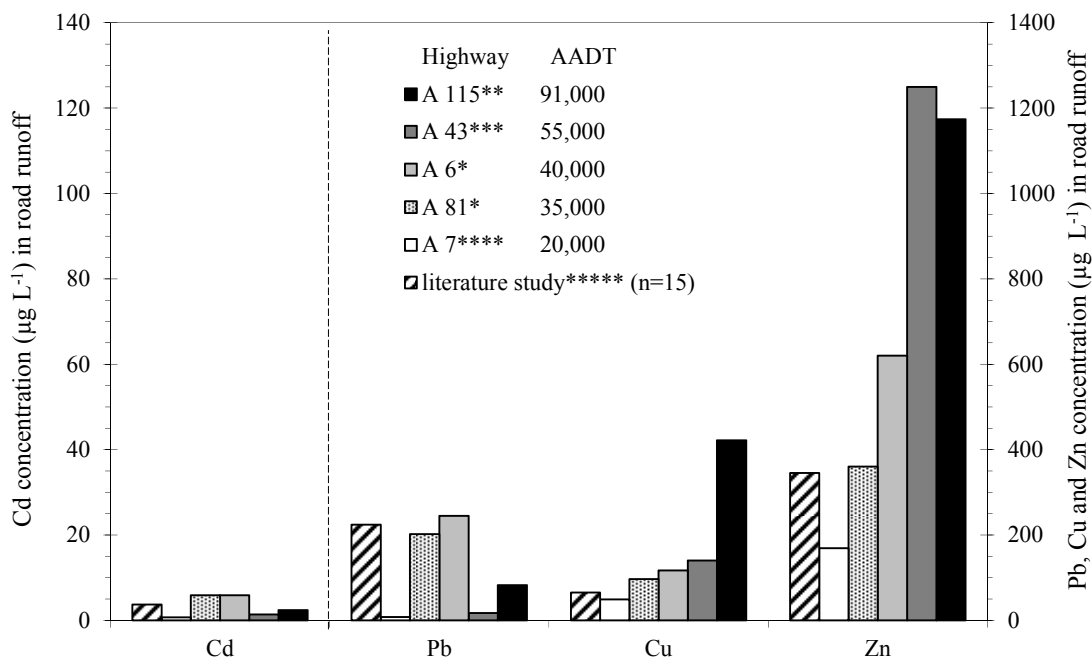

Fig. 3.4: Mean total metal concentrations of AVUS runoff compared with mean runoff concentrations from other authors (\*Krauth and Klein 1990 in Muschak 1990; \*\*this study; \*\*\*Dierkes and Geiger 1999; \*\*\*\*Diehl 2002 in Kluge. 2010; \*\*\*\*\*Göbel et al. 2007). Dashed line separates the two different y-scales.

The Cu concentrations of A 115 and Zn concentration of A 115 and A 43 are higher than at the rest of the highways. The concentrations of Pb and Cd in runoff of the A115, A7 and A43 are below the other runoff values. The lower Pb concentrations could be due to the ban on Pb use in gasoline in 1988 (in Germany). The runoff data from the study of Krauth and Klein (1990) and the literature data of Goebel et al. (2007) were mostly determined before 1988. This might be the reason for the sharp decline in Pb concentrations in runoff determined by Dierkes and Geiger (1999), Diehl (2002) and this study. In relation to the annual average daily traffic (AADT) metal concentrations are, despite different sampling dates, intervals and rain events, in the same order of magnitude.

### 3.3.3. Soil metal concentrations

The mean pseudo-total soil metal concentrations of the embankment soils (T) are shown in Fig. 3.5 (for details see Tab. S3 in the supplementary material). The metals Cd and Zn show highest median concentrations at the soil surface (0-10 cm) and at 5 m distance from the roadside, whereas the highest median Pb, Ni, Cu and Cr concentrations were observed at 2.5 m from the road. At the study site, concentrations of all metals are greatly increased at all investigated depths (0-10 and 10-25 cm) and distances (2.5, 5 and 7.5 m) compared to background levels for the region Berlin/Brandenburg and the reference site at 800 m distance to the road (Fig. 3.5). It is well documented that metals are roadside soils are greatly increased compared to their specific background concentrations (Werkenthin et al., 2014).

Zinc is the metal with the highest levels in the soil with a range from 49 to 626 mg kg<sup>-1</sup>. Median concentration at 5 m is 277 mg kg<sup>-1</sup>; which is approximately fifteen times higher than the median concentration at the reference site at a distance of 800 m. Cadmium concentrations ranged from 0.3 to 10.4 mg kg<sup>-1</sup>. The median concentration at 5 m is 3.29 mg kg<sup>-1</sup>. This value is about thirty times higher than the median concentration at the reference site. Concentrations of Pb ranged from 15 to 386 mg kg<sup>-1</sup>. Median Pb concentration at 2.5 m is 245 mg kg<sup>-1</sup>, which is ten times higher than the median concentration at the reference site. Nickel concentrations varied between 0.4 to 26.6 mg kg<sup>-1</sup>. The median Ni concentration at 2.5 m is 11.4 mg kg<sup>-1</sup>, which is thirteen times higher than the median background level of the region Berlin/Brandenburg. Copper concentrations ranged from 7.3 to 182 mg kg<sup>-1</sup>. The median concentration at 2.5 m is 74 mg kg<sup>-1</sup> which is about thirty times higher than the median concentration at the reference site. Chrome concentrations ranged between 3.6 and 42.9 mg kg<sup>-1</sup>. The median concentration at 2.5 m is 25.4 mg kg<sup>-1</sup>, which is ten times higher than the background value for the region Berlin/Brandenburg. The wide range of metal concentrations at the same distance and depth (suppl. material) could be explained by heterogeneous road runoff distribution across the embankment surface, which in turn would lead to a non-homogenous infiltration pattern at the study site.

Metals may accumulate at the preferential flow domains (Garrido and Helmhart, 2012), leading to large variations in metal concentrations. Despite the elevated concentrations compared to background levels, median Cr and Ni concentrations do not exceed the precautionary values of the German Federal Soil Protection and Contamination Ordinance (BBodSchV) at any depth or distance (Table 3.3). Median Cd, Cu, Pb and Zn concentrations exceed the precautionary values at all investigated distances and depth except for Cu at 2.5 m distance and 10-25 cm soil depth.

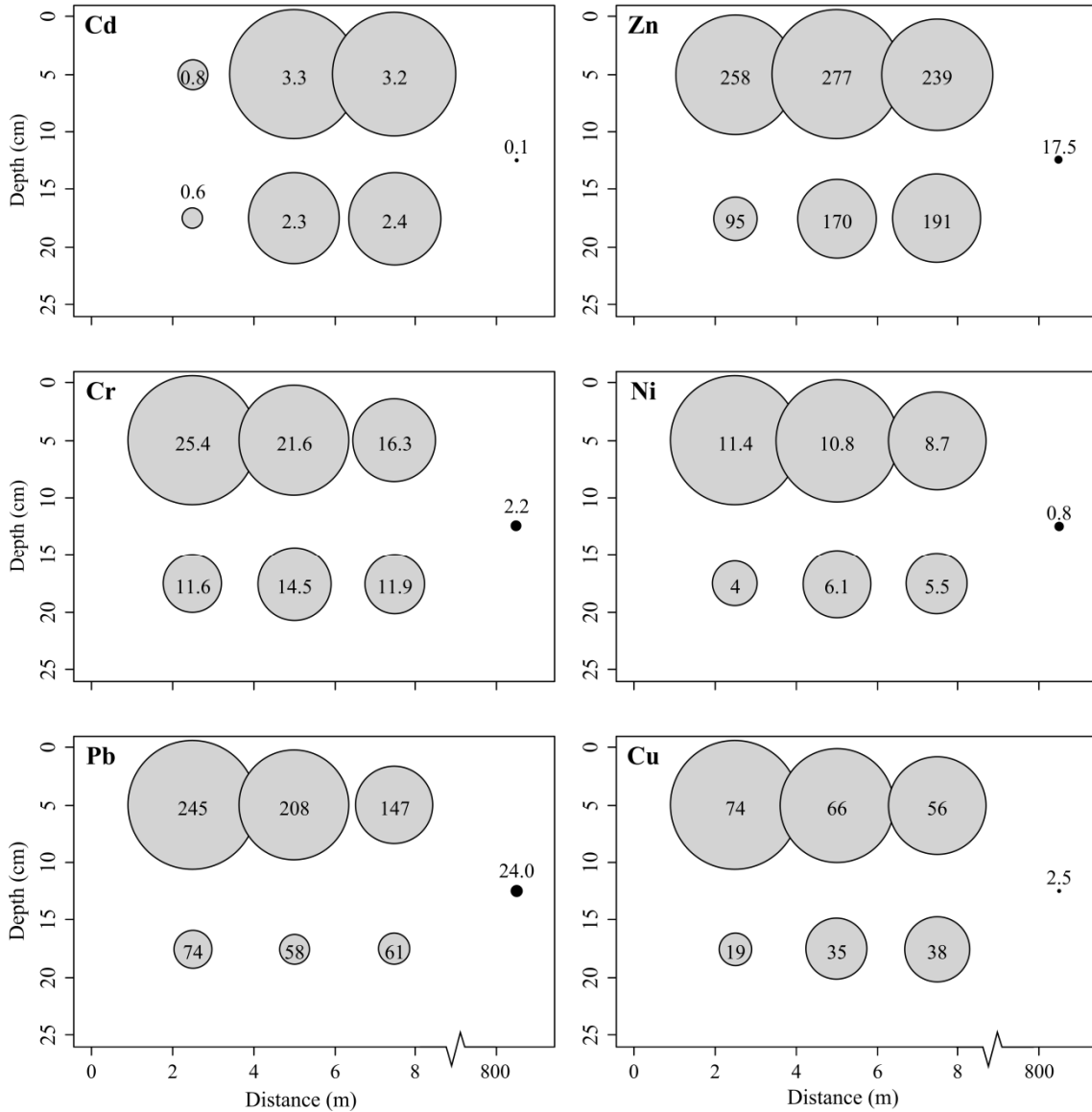

Fig. 3.5: Median concentrations in mg kg<sup>-1</sup> of metals in the embankment soils (T) at different depths and distances and at the reference site (n=90). The background levels of Ni and Cr are for the region Berlin/Brandenburg. The radius of the circles is proportional to the median concentration of a specific element.



Tab. 3.3: Precautionary values for sandy soils and trigger values for the transfer of soil solution to the groundwater of the German Federal Soil Protection and Contamination Ordinance (BBodSchV, 1999) Germany.

<i>Metal</i>	<i>Cd</i>	<i>Cr</i>	<i>Cu</i>	<i>Ni</i>	<i>Pb</i>	<i>Zn</i>
<i>Soil matrix (mg kg<sup>-1</sup>)</i>	0.4	30	20	15	40	60
<i>Soil solution (µg L<sup>-1</sup>)</i>	5	50	50	50	25	500

At the AVUS embankment Pb, Ni, Cu and Cr concentrations in the topsoil decrease with increasing distance to the road which is in line with the findings of other authors (e.g. Motto et al., 1970; Turer and Maynard, 2003; Modrzewska and Wyszowski, 2014) who analysed contamination patterns of metals in roadside soils. Decreasing metal concentrations with distance could be explained by higher input rates of traffic-derived metals due to airflow, runoff- and splashing water near the road. The inclination of the embankment promotes the transport of metals by runoff water up to 7.5 m distance. For Zn and especially for Cd, higher concentrations at a distance of 5 m were measured compared to 2.5 m. This is in line with the findings of Hjortenkrans et al. (2008), who also determined higher Cd and Zn concentrations at 5 m distance compared to 2.5 m at the E22 Highway, Sweden. Enlarged infiltration rates of road runoff and spray water at 2.5 m distance (Kocher et al., 2005) could increase the leaching of Cd and Zn from soil matrix since they are the most mobile of the elements analysed (Alloway, 2012).

Another reason for a higher leaching and in turn lower Cd and also Zn concentrations could be the use of road side agents in the winter period. Kluge and Wessolek (2012) measured high electric conductivity (EC) values in soil solution at 2.5 m from December to March 2008 at the AVUS highway site. Several authors determined a high mobility and leaching of Cd and Zn in the presence of road deicing agents like NaCl (Amrhein et al., 1992, Bäckstrom et al., 2004, Green et al., 2009).

At the study site all metal concentrations decrease with increasing soil depth. The decrease of metals in roadside soils with increasing depth has often been observed (Werkenthin et al., 2014). Boivin et al. (2008), who observed similar patterns, concluded that physical retardation of particulate bound metal leads to increasing concentrations in the topsoil. Furthermore, the elevated OC and clay content in the topsoil increases the sorption capacity in this layer and therefore provides for a high metal retention (Turer et al., 2001; Kluge and Wessolek, 2012). An influence of traffic-derived metals could still be observed at 10-25 cm depth. Comparison with background concentrations shows elevated concentrations for all metals. Other authors determined elevated soil metal concentrations up to 40 cm depth (Legret and Pagotto, 2006; Steiner et al., 2007; Motuzas, 2008).

### 3.3.4. Soil solution metal concentrations

The concentrations of the dissolved and particle-bound metals in soil solution at 2.5 m distance to the roadside are shown in Fig. 3.6. Zinc is the metal with the highest mean dissolved concentration ( $240 \mu\text{g L}^{-1}$ ) whereas the highest mean particle-bound concentration was determined for Cu ( $54 \mu\text{g L}^{-1}$ ). Cadmium has the lowest observed mean particle-bound and mean dissolved concentration with  $0.9$  and  $1.4 \mu\text{g L}^{-1}$  respectively. The ratio of particle-bound to dissolved metals in soil solution for Zn is about 1:12, for Pb 1:0.9, for Ni and Cr 1:3, for Cu 1:4 and for Cd 1:1.5. Compared to the dissolved metal concentrations in road runoff (Fig. 3.3), the soil solution concentrations of Pb, Cu and Ni were significantly higher. One explanation for this could be that due to high metal concentrations in the soil matrix (Fig. 3.5), the soil solution is enriched with metals.

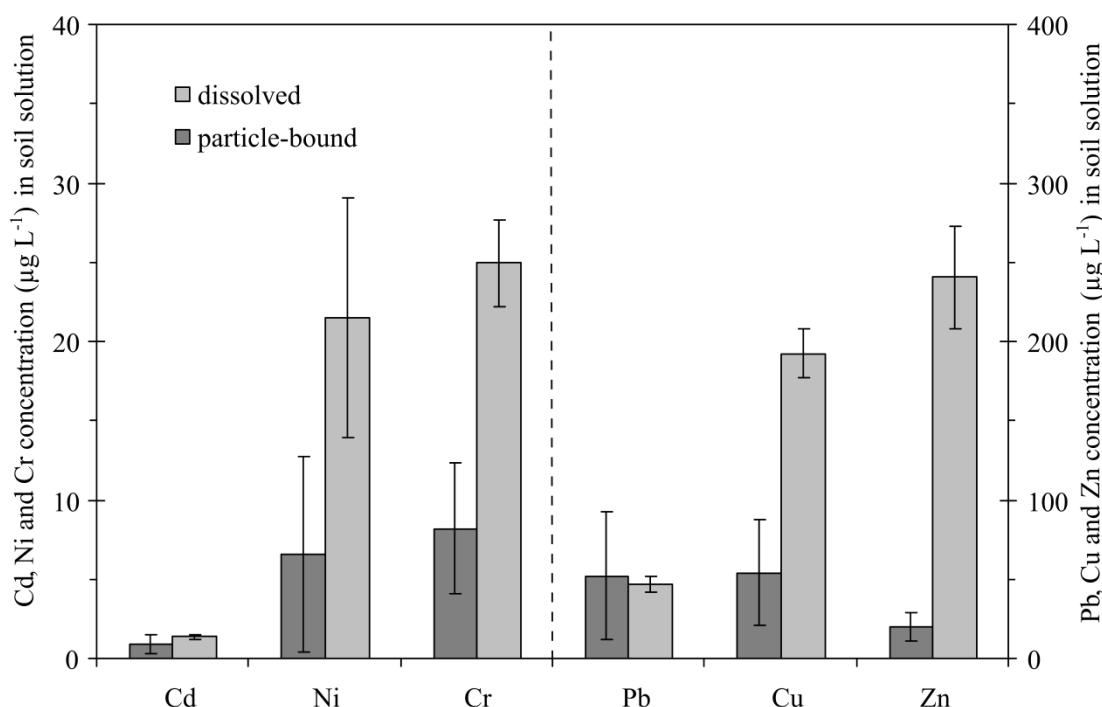

Fig. 3.6: Mean dissolved and particle-bound metal concentrations in soil solution at 2.5m distance from the AVUS roadside-50 cm soil depth. Dashed line separates the two different y-scales.

Because of the special hydrological conditions in soils adjacent to the road, even light rainfall events can lead to a total exchange of the soil solution in the upper 50 cm and therefore to a complete transfer of the soil solution into the wick lysimeter. Another reason could be the use of de-icing agents for road maintenance during the sampling period. The transfer of NaCl into the roadside soils is indicated by the increased conductivity of soil solutions with  $2500 \mu\text{S cm}^{-1}$ . In winter periods pollutant levels are often higher than during summer because of accumulation within layers of snow and the use of de-icing salts (e.g. Legret and Pagotto, 1999; Norrström and Jacks, 1998).

In laboratory studies Amrhein et al., (1992) could show that mobilisation of metals from roadside soils is enhanced by the infiltration of salty runoff. Bäckström et al. (2004) determined a correlation between the concentration of Cd, Cu, Pb and Zn in soil solution and the application of de-icing salts in field studies. The high sodium content in soil leads to a dispersion of fine soil particles and dilution of dissolved organic matter (DOM) which in turn increases the metal mobility (Ramakrishna and Viraraghavan, 2005).

For all metals, particle-bound concentrations are lower in soil solution than in road runoff (Fig. 3.3 and Fig. 3.6). This indicates that the physical retardation of the sandy topsoil at the study site for small size particles from road runoff is high. Boivin et al. (2008) also determine a high physical retardation of road pollutants for sandy loam soils in Switzerland. In the infiltration experiments of Blecken et al. (2010) the retention of particle-bound metals ranged from 89 to 99 % in sandy topsoils. Only mean Pb and Cu concentrations measured with wick lysimeter exceeded the trigger values of the BBodSchV (Table 3.3). Even under consideration of particle-bound metals, total concentrations of Cd, Zn, Ni and Cr do not exceed trigger values. The median dissolved concentrations measured with suction cups over one year at the nearby monitoring site are also below trigger values except for Cu ( $156 \mu\text{g L}^{-1}$ ). For further information about soil solution concentrations measured with suction cups ( $n=90$ ) at different distances and depths see Kluge and Wessolek (2012).

### 3.3.5. Adsorption experiments

Freundlich adsorption isotherms for Pb, Cd, Zn and Cu of the embankment soil (B) and reference soil (800 m distance) are shown in Fig. 3.7. The coefficients of determination ( $r^2$ ) of the isotherms are very high and range between 0.92 (Pb) and 1 (Zn and Cu).

The results show significantly higher Freundlich adsorption coefficients  $K_F$  of the embankment soil (B) for all metals compared to the reference soil (R). In order to compare different adsorption characteristics with different degrees of linearity the retardation factors ( $R_F$ ) were calculated. These describe the mobility or the delay of a substance compared to the transport medium in solid-liquid phases (Table 3.4).

The retardation factors for Zn, Cd, Cu and Pb of the AVUS embankment soil are 10 to 20 times higher compared to the reference soil. For the embankment (B) and the reference soil Pb has the highest  $R_F$  followed by Cu, Cd and Zn, which has the smallest  $R_F$ . This suggests that Zn and Cd have a high mobility associated to a low adsorption whereas Cu and especially Pb present the opposite behaviour. The results of the adsorption isotherms suggest that the metals investigated, especially Pb, are relatively immobile at the AVUS soil. The increase of sorption capacity of the embankment soil (B) is presumably caused by multiple effects.

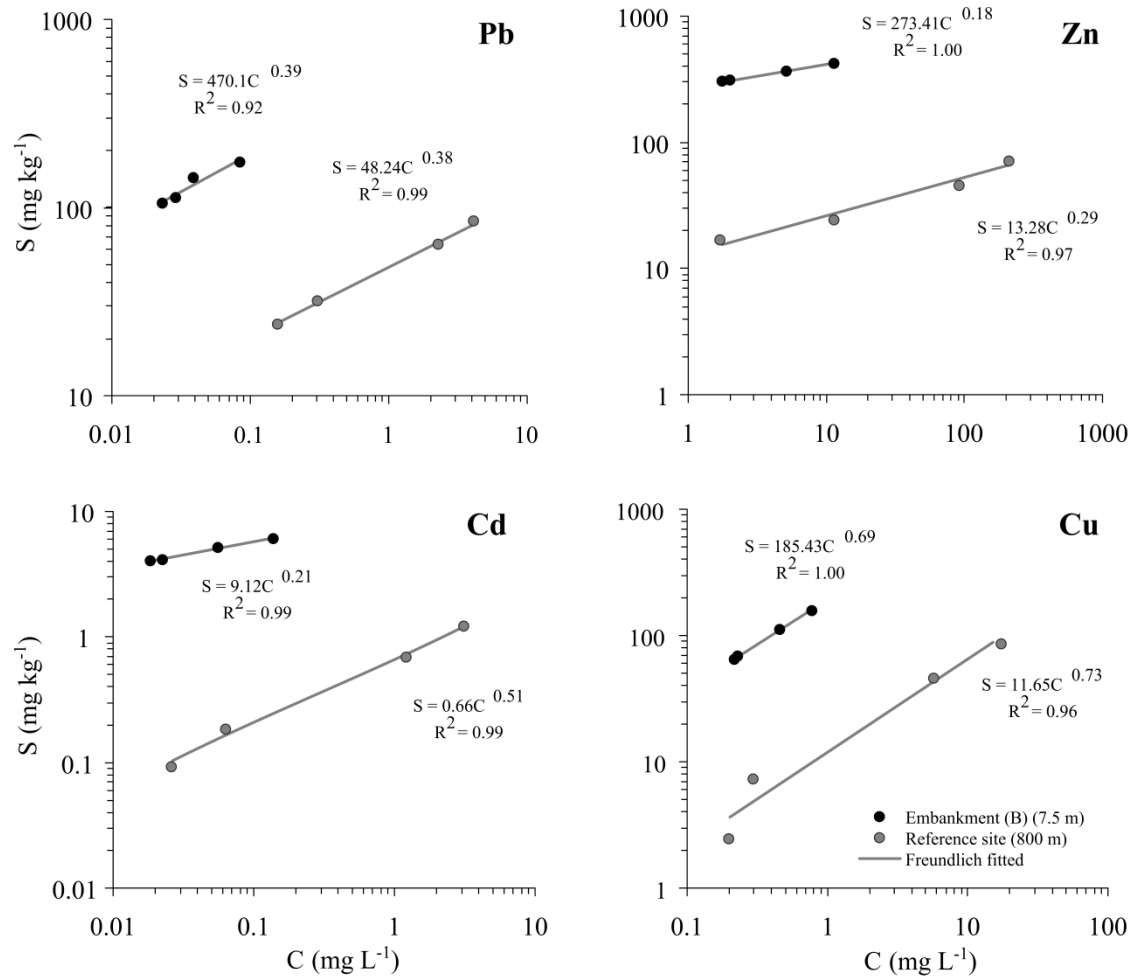

Fig. 3.7: Adsorption isotherms of Pb, Cd, Cu and Zn from the AVUS embankment soil (B) and the reference soil (R) at 800 m distance from the roadside.

One important factor is the higher pH value (5.6) of the embankment soil (B) compared to the reference site (3.9). The mobility of all metals decreases with increasing soil pH. This can be related to both the increasing of specific and non-specific adsorption and precipitation reactions (Mc Bride, 1994; Merdy et al., 2009). Especially at a distance of 0 up to 10 m from the roadside edge, the soils are usually characterised by rearranged substrate, often interspersed with bitumen, cement and other typical building materials, which are mostly calcareous.

Tab. 3.4: Retardation factors of the AVUS embankment soil (B) and the reference soil (R) at 800 m distance from the road.

Soil	$R_F$			
	Zn	Cd	Pb	Cu
Embankment (B)	225	475	3500	1019
Reference (R)	19	21	350	66

The presence of these materials, among other factors like alkaline dust depositions from the road surface, causes an increasing soil pH (Wessolek et al., 2011). Other important factors are the higher OC as well as higher clay content compared to the reference soil. Among others, Turer and Maynard (2003) pointed out that the metal concentrations in roadside soils are positively correlated to the OC content of the soils.

Particles from tire wear, black carbon (BC) and other traffic specific substances can significantly increase adsorption capacity of roadside soils (Liang et al., 2006; Nehls et al., 2008). He and Zhang (2009) determined a high presence of BC in the surface layer of soils in regions with high traffic emissions. They found a positive correlation between BC and the adsorption of metals whereas natural OC can produce large amounts of leached DOC which in turn increases Cu and also Pb mobility (Mc Bride, 1994; Rijkenberg and Depree, 2010). Zhang et al. (2008) could show that an additional 2.5% of fly ash in sand increases the  $R_F$  of Cu, Pb and Zn by a factor of three to six.

### **3.3.6. Soil solution concentrations-comparison of laboratory and field data**

In order to evaluate the batch leaching concentrations obtained in this study, laboratory leaching experiments (batch SSE, batch S4, soil columns and calculated adsorption isotherms) of the embankment soil (B) were compared (Fig. 3.8) with field data delivered by the suction cup monitoring field at 7.5 and 10 m distance from the road (Kluge and Wessolek, 2012). Median metal concentrations determined with batch SSE and column experiments were all significantly higher than median concentrations measured in the field. The biggest difference was determined for Pb, whereby concentrations in batch SSE are about 14 times and in column experiments 18 times higher than suction cup data. Since Pb is the least mobile of the analysed elements this could be explained by the destruction of soil aggregates and organic coatings by stirring in the batch SSE. Higher concentrations in the column experiment could be explained by filling, compacting, drying and rewetting processes (Bartlett and James, 1980; Makino et al., 2000). Metal concentrations determined in the batch S4 experiment are lower than median field concentrations except for Pb. This is probably due to the high water soil ratio of 10:1 resulting in a dilution of the metal concentrations (Schuwirth and Hofmann, 2006).

The soil solution concentrations of Pb, Cu and Cd calculated with adsorption isotherms are considerably higher than median field concentrations, whereas Zn concentrations are only slightly higher. The comparison of different laboratory leaching experiments shows that soil solution concentrations from adsorption isotherms and batch S4 experiments have a high level of agreement with field measurements. Schuwirth and Hofmann (2006) however concluded that batch SSE and column experiments are more comparable to soil solution concentrations in field.

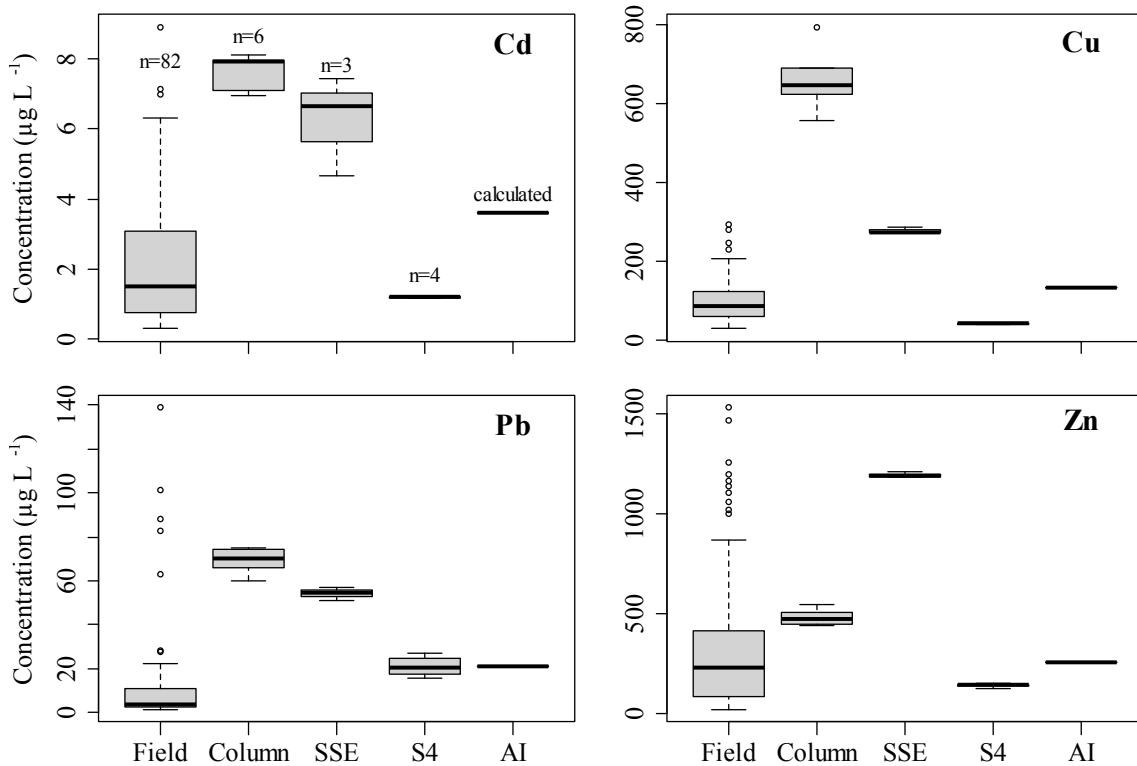

Fig. 3.8: Comparison of the Cd, Cu, Pb and Zn concentrations in soil solution determined in field studies (suction cups), laboratory experiments (column, batch SSE and batch S4) and calculated values using the adsorption isotherms (AI).

### 3.4. Conclusions

The runoff from the AVUS highway shows elevated metal concentrations whereby the content of particle-bound metals varied, depending on the element. Due to the infiltration of road runoff into the surrounding embankment, significant loads of metals are introduced into the soil. The investigated roadside soils showed highly elevated metal levels which were up to thirty times higher than background levels at the reference site. Most median metal concentrations in the AVUS embankment soil (T) exceed the precautionary values of the German Federal Soil Protection and Contamination Ordinance. Nevertheless, enhanced infiltration of road runoff at 2.5 m distance increased metal leaching from soil. Leaching processes from soil matrix are mainly responsible for the elevated dissolved metal concentrations in soil solution. The particle-bound metals from road runoff are, to a great extent, retained by the AVUS embankment soil (T) and play a minor role in terms of exceeding the trigger values. Adsorption experiments showed higher metal retardation in the embankment soil (B) than in the reference soil. Retardation capacity of AVUS roadside soils therefore increased during long-term operational time.

Metal concentrations determined with batch S4 experiment and calculated with adsorption isotherms show an acceptable level of agreement with field measurements. The use of batch S4 experiments is therefore a relatively simple and cheap alternative to field studies to predict metal concentrations. Nevertheless onsite measurements are essential to answer specific questions in terms of a risk assessment.

### **Acknowledgements**

We thank Michael Facklam for the support of field installations, soil sampling and transect mapping and Thomas Nehls for the aid with adsorption isotherm experiments. We are also grateful to colleagues at the Department of Ecology, Soil Conservation, Technische Universität Berlin for laboratory analyses.

## 4. Assessment of metal retention in newly constructed highway embankments<sup>3</sup>

Moritz Werkenthin\*, Björn Kluge and Gerd Wessolek

Department of Ecology, Soil Conservation, Technische Universität Berlin,  
Ernst-Reuter-Platz 1, 10587 Berlin, Germany

(\*author for correspondence, e-mail: moritz.werkenthin@tu-berlin.de, Tel.: +49 30 31473525)

### **Abstract:**

Newly constructed embankments should provide both a specific bearing capacity to enable trafficability in emergency cases and a sufficient pollutant retention capacity to protect the groundwater. A number of lysimeters were installed along the A115 highway to determine total and dissolved metal concentrations in road runoff and in the soil solution of newly constructed embankments. Dissolved concentrations in soil solution of the embankments did not exceed the trigger values of the German legislation. Depending on the metal, total concentrations in soil solution were more than twice as high as dissolved concentrations. The high infiltration rates lead to increased groundwater recharge beneath the embankments (up to 4,100 mm a<sup>-1</sup>). Although metal concentrations were not problematic from the legislators' point of view, the elevated infiltration rates beside the road facilitated the transfer of high metal loads into deeper soil layers and potentially into the groundwater as well.

**Keywords:** Highway embankments; Heavy Metal; Soil solution; Particulate Transport; Metal Load; Groundwater Pollution

---

3 Submitted to Environmental Science and Pollution Research (18.05.2015), Werkenthin, M; Kluge, B and Wessolek, G.



## 4.1. Introduction

The diffuse infiltration of highway runoff into the adjacent embankment is an important component in stormwater management practice (Boivin et al., 2008; Piguet et al., 2008). In this concept, the embankment soils are used as a natural filter to reduce runoff quantity and to promote pollutant retention through physical and chemical retardation. However, the infiltration of highway runoff into the embankment potentially degrades soil and groundwater quality (Van Bohemen and Van de Laak, 2003; Weiss et al., 2008; Hilliges et al. 2013).

Typically, highway runoff contains nutrients, heavy metals, polycyclic aromatic hydrocarbons and road salts that can occur in particulate and dissolved form. Many studies on traffic-derived pollutants and their concentration ranges have been conducted (Göbel et al., 2007; Helmreich et al. 2010; Folkeson et al., 2009; Kayhanian et al., 2012; Zuo et al., 2012). In particular, metals are pollutants of major concern due to their persistent and bio-accumulative nature. Although some metals are essential trace elements, most can be toxic to plants, microbes, humans and animals at a certain level of exposure (Goyer and Clarkson, 1996). As many authors could show, metal levels in roadside soils are often elevated compared to geological background (Turer et al., 2001; Carrero et al., 2013; Simon et al., 2013). Normally, the concentrations decrease with increasing soil depth and distance to the road (Legret and Pagotto, 2006; Hjortenkrans et al., 2008; Werkenthin et al., 2014).

Metals from the highway runoff are largely retained in the topsoil layer due to physical retardation and adsorption to the soil matrix (Turer and Maynard, 2003; Boivin et al., 2008). External influences like dry periods, long intensive rainfall events or use of de-icing agents can lead to a mobilisation of the easily exchangeable metal fraction (Amrhein et al., 1992; Hjortenkrans et al., 2008; Blecken et al., 2009). Among others Bäckström et al. (2004) and Kluge and Wessolek (2012) analysed dissolved metal concentration in soil solution at highly trafficked roadsides to estimate the risk of groundwater pollution. The latter rarely observed metal concentrations exceeding the national trigger values of the German Federal Soil Protection and Contamination Ordinance (BBodSchV, 1999). Kluge et al. (2014) who also measured particle-bound metals in soil solution of embankments could show that particle-bound metals play a minor role in terms of exceeding national trigger values of the BBodSchV (1999). Consisting embankment soils therefore provide a sufficient retention capacity and elevated metal concentrations in soil solution and groundwater are limited (Dierkes and Geiger, 1999; Kocher et al., 2005). Similar results were obtained in numerous field and laboratory studies analysing the efficiency of metal retention from road runoff in stormwater infiltration systems (Davis et al., 2003; Weiss et al. 2008; Ingvertsen et al., 2012a; LeFevre et al. 2014).

Nonetheless, the infiltration of highway runoff into the embankment significantly increases the groundwater recharge causing a noticeable transfer of metals to the groundwater aquifer (Kocher et al., 2005).

According to the German Road and Transportation Research Association (FGSV) the term embankment refers to the first of 1.5 m beside the paved road surface. Thus embankments legally belong to the road structure and primarily need to fulfil requirements set out in road construction regulations (RAS-Ew, 2005), unlike stormwater infiltration systems which are only designed to retain pollutants from road runoff (El-Mufleh et al., 2014). Due to recent changes set out in German road construction regulations, newly constructed highway embankments have to provide a specific bearing capacity to enable trafficability in emergency cases (ZTVE-StB, 2009). The materials used for embankment construction therefore have to consist of accurately defined gravel-soil mixtures, which can meet this requirement. However, increasing the gravel content of the embankment soils in order to ensure drivability leads to decreasing sorption capacity. Furthermore, transport mechanisms such as preferential flow and particle-bound metal transport (Roulier et al., 2008; Garrido and Helmhart, 2012) could become more important in the newly constructed embankments. Although laboratory experiments with gravel filter media indicate an effective removal of pollutants from stormwater runoff (Hatt et al., 2007), no field study on metal retention of stable gravel embankments has been performed to date.

The objectives of this study were to determine the total and dissolved concentrations of Cd, Cr, Cu, Ni, Pb and Zn in the soil solution of different newly constructed embankments. Another aim was to compare the groundwater recharge rates and metal loads of different embankment constructions.

## 4.2. Material and methods

### 4.2.1. Study site

The A115 is located in the southwest of Berlin, Germany (52° 23 27.5 N, 13° 09 42.8 E), surrounded by a mixed pine-oak forest beginning at a distance of about 15 m from the road. The nearby soils are mainly Spodo-Dystric Cambisols (FAO, 2006). The traffic volume at the study site ranges between 63,000 – 80,000 vehicles per day, with 6-7% of heavy traffic (Fitschen and Nordmann, 2012) and a speed limit of 120 km h<sup>-1</sup>. In this section, the highway is 34 m wide (including central reservation) and has three concrete lanes per direction. The sealed road surface has a width of 15 m in each direction and is drained across the adjacent embankment. Relative elevation of the highway is about 2 m; the longitudinal inclination is 1%. At the study site, no crash barriers are installed.

Annual average temperature is 8°C and precipitation is 580 mm. The annual groundwater recharge rate for the surrounding area (grassland) calculated with a hydro-pedotransfer function (Wessolek et al., 2004) is 180 mm.

#### 4.2.2. Lysimeter construction

##### Collection of soil solution

To determine metal concentrations in the soil solution of stable gravel embankments three PE-lysimeters were placed at the A115 highway. They have the following dimensions: length: 150 cm, width: 100 cm, height: 60 cm (Fig. 4.1). The lysimeters were installed directly beside the road edge in November 2012. The lysimeters were filled with different soil materials, which were recently used for embankment construction in Germany:

1. Conventional embankment material (surrounding topsoil) as a non-stable reference (TSM)
2. Base course construction material from natural broken rock and sand (BCM)
3. Mixture of BCM and 15% TSM (MTB)

The embankment soils investigated were obtained from a nearby highway construction site. The thickness of the embankment layer was 20 cm for the TSM and 30 cm for the BCM and MTB equivalent to a soil volume of 0.3 and 0.45 m<sup>3</sup> respectively. To prevent water-logging a staggered drainage layer made of washed and lime-free gravel and coarse sand was placed beneath the embankment soils. As per road construction regulations, the embankment soils were compacted after installation and greened with grass vegetation as the surrounding embankments.

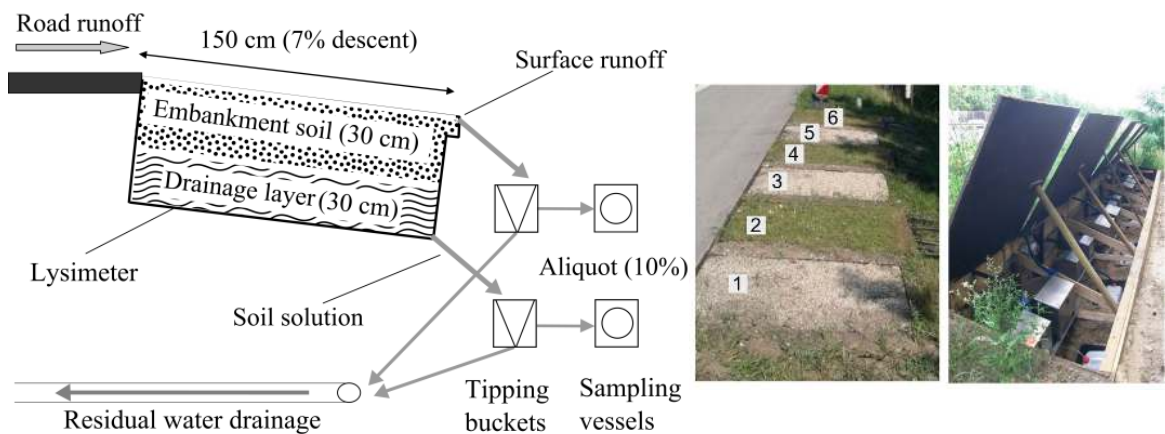

Fig. 4.1: Schematic sketch of an embankment lysimeter with tipping buckets and sampling vessels (left). Pictures of the six lysimeters (middle), tipping buckets and sampling vessels (right). The runoff lysimeters are marked with 1, 3 and 5, the embankment lysimeters with 2, 4 and 6.

The embankment lysimeters were constructed with two discharges; one to collect the surface runoff and one to collect soil solution at 60 cm depth. The water volumes were measured by tipping buckets (type: V2A, UP- GmbH). Tipping signals were recorded automatically, to quantify the water that passed through the lysimeters. An aliquot of the water volumes was collected in PE vessels as composite samples. Sampling was conducted once a month, the sampling period ran from July 2013 to July 2014.

### **Collection of road runoff and sediments**

Three further lysimeters (RR1-RR3) were installed to determine the incoming metal concentrations from road runoff. They have the same surface area as the embankment lysimeters (1.5 m<sup>2</sup>) but are only 15 cm high (length: 150 cm, width: 100 cm, height: 15 cm). The runoff lysimeter have only one discharge at the bottom of the lysimeter. They are located in between the embankment lysimeters to quantify the variability of runoff quantity (Fig. 4.1). The runoff lysimeter were filled with lime free, washed pebble gravel ( $\varnothing$  5.6-8 mm) to meet the road safety regulations. This construction lead to an accumulation of road sediments in the runoff lysimeters over time. After one year of operation, these sediments were removed, collected and analysed for metal concentration in the laboratory to determine total metal input. The water volumes were also measured by tipping buckets and recorded automatically; aliquot composite samples were collected in PF vessels. Sampling was conducted once a month, the sampling period ran from July 2013 to July 2014. All six lysimeters (embankment and runoff) have an inclination of 7% equivalent to the surrounding embankment. Furthermore, a weather station was installed to determine precipitation, temperature, humidity and potential evaporation in 15 minute intervals.

### **Calculation of metal loads**

To calculate metal loads that passed through the embankment constructions (lysimeter output) during the course of one year, median concentrations of the soil solutions (dissolved + particle-bound) were multiplied with the soil solution volume of the related lysimeter (potential groundwater recharge rate). The metal loads that were introduced into the embankment lysimeters (lysimeter input) were calculated by multiplying the median concentrations in road runoff (dissolved + particle-bound + sediment) with the water volume of the runoff lysimeters in the corresponding period. Lysimeter in and output loads were normalised to one embankment square meter.

#### **4.2.3. Laboratory analysis**

Dissolved concentrations of Cd, Cu, Cr, Ni, Pb and Zn were determined in the soil solution and road runoff. One part of the sample was filtered through 0.45  $\mu$ m (Satorius; cellulose-acetate) and acidified with 5M HNO<sub>3</sub> to pH <2.

The other part of the sample was digested with HNO<sub>3</sub> in a microwave (CEM MARS 5) according to DIN EN ISO 15587-2 to analyse total metal concentrations (particle-bound + dissolved). Pseudo total metal contents of the embankment soils (fraction <2mm) and sediments were determined by aqua regia digestion in closed vessels in a Multiwave 3000 microwave oven (Perkin Elmer Instruments) according to DIN ISO 11466. All samples were measured with ICP-OES (Thermo Fisher ICAP 6000) according to DIN EN ISO 11885. Limits of quantification (LOQ) were 0.09 (Cd), 0.3 (Cr), 0.8 (Cu), 0.8 (Ni), 2 (Pb) and 0.1 (Zn)  $\mu\text{g L}^{-1}$ . In order to ensure a good measurement quality the maximum permissible deviation for individual metal recovery from reference material was set to  $\pm 8\%$ .

### 4.3. Results and discussion

#### 4.3.1. Properties of the embankment soils

The embankment soils of the lysimeter all have a pH value slightly above neutral (Tab. 4.1). Organic carbon content (C<sub>org</sub>) of the different materials is relatively low, which is typical for the soils in this region. The BCM has the highest proportion of gravel followed by the MTB, ensuring drivability in emergency cases. The TSM is a loamy sand containing only minor parts of gravel, which roughly corresponds to the existing embankment soils in the surrounding (Kocher et al., 2005; Kluge and Wessolek, 2012). Copper, Pb and Zn concentrations were lowest for the BCM and highest for the TSM, Ni was highest for the MTB. Cadmium and Cr were below the limit of analytical determination.

Tab. 4.1: Heavy metal concentrations, soil properties (fraction <2 mm) and texture of the embankment soils.

	Cd	Cr	Cu	Ni	Pb	Zn	pH	C <sub>org</sub>	CaCO <sub>3</sub>	Gravel	Sand	Silt	Clay
	mg kg <sup>-1</sup>							g g <sup>-1</sup>					
<b>BCM</b>	<0.2	<5	5	5	5	19	7.67	0.13	0.52	75.3	23.6	0.8	0.3
<b>TSM</b>	<0.2	<5	20	<5	25	33	7.57	0.88	0.01	4.0	84.8	8.7	2.5
<b>MTB</b>	<0.2	<5	11	6	13	30	7.63	0.40	0.37	63.3	34.6	1.5	0.6

#### 4.3.2. Runoff volume and infiltration rates

Precipitation at the study site was 514 mm during the period 01.07.2013-31.06.2014. Assuming a catchment area of 16.5 m<sup>2</sup> and a mean runoff coefficient of 0.7 (-) the total calculated amount of runoff is about 5,900 mm. However the mean annual amount of road runoff measured in the road runoff lysimeters was 12,300 mm varying from 7,000 – 19,000 mm (Fig. 4.2).

These strong variations in between the runoff volumes of the lysimeters and the calculated runoff volume were not expected since the highway surface was rebuilt in 2001 and depressions or irregularities were not apparent. Thus it must be assumed that the large differences are caused by local conditions like small scale road depressions, surface roughness, longitudinal gradient, concrete joints, precipitation intensity and duration, traffic activity and road maintenance. These factors influence the catchment areas and thus the runoff volumes as shown in several studies (e.g. Hollis and Ovenden, 1988; Ragab et al., 2003; Wessolek et al., 2011). The combination of these factors leads to complex, highly dynamic catchment areas (Mansell and Rollet, 2006) which in turn may result in very diverse lysimeter runoff volumes. This assumption can also be deduced by the permanently changing runoff ratio recorded by the tipping buckets of the runoff lysimeters (supplementary material – S1). Hydraulic loading of embankment soils thus may vary strongly on a small scale.

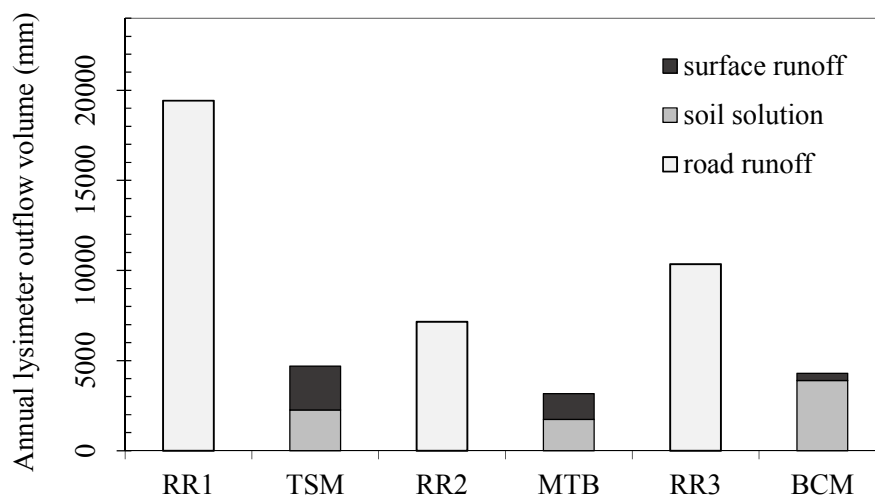

Fig. 4.2: Annual water volume (mm) of the runoff (RR1-3) and embankment lysimeters (TSM, MTB, BCM).

The mean annual water volumes of the embankment lysimeters (soil solution + surface runoff) showed significantly less deviation compared to the volumes determined in the runoff lysimeters (Fig 4.2). The differences between the soil solution volumes of the embankment lysimeters can rather be attributed to the different ratio of the surface runoff volumes. The percentage of surface runoff is lowest at the BCM lysimeter (8%) whereas surface runoff at the TSM and MTB embankment lysimeter ranges between 50-55%. Grain size distribution of the BCM embankment soil (Tab. 4.1) could lead to a high infiltration capacity. Although the MTB soil also contains a large gravel (>2 mm) fraction (48%) the higher amount of soil <0.063 mm (5.5%) could lead, in combination with the prescribed compaction, to a much smaller infiltration rate.

In a study on hydraulic permeability of compacted construction materials comparable to the BCM and MTB, Radenberg and Kollar (2012) could show that increasing the soil fraction  $<0.063$  mm of a gravel sand mixture by 5% led to a decrease of the infiltration rate around two orders of magnitude ( $3 \cdot 10^{-4}$  to  $4 \cdot 10^{-6}$  m s<sup>-1</sup>).

Soil solution volume and accordingly the potential groundwater recharge rate is highest beneath the BCM lysimeter (4,100 mm), whereas beneath TSM and MTB lysimeter it is 2,200 and 2,000 mm. The potential evapotranspiration (PET) during the period was approximately 740 mm. Due to the high amounts of infiltrating road runoff, the potential groundwater recharge rate of the embankments is up to 22 times higher than the natural rate for the surrounding area. To our knowledge, no field measurements of groundwater recharge rates from highway embankments sites have been published. However, Kocher and Wessolek (2002) predicted an annual groundwater recharge rate of 4,000-5,500 mm for a sandy roadside soil (0-1 m beside the road) at similar climatic conditions using a soil water model.

#### **4.3.3. Metals in road runoff**

Highest median dissolved ( $<0.45$   $\mu\text{m}$ ) and particle-bound ( $>0.45$   $\mu\text{m}$ ) metal concentrations in road runoff were determined for Zn and Cu; Cd had the lowest concentrations (Fig. 4.3). During the sampling period only median total Pb concentration (dissolved + particle-bound) in road runoff exceeded the European threshold value for drinking water (Directive, EC Council 1998: Cd 5, Cr 50, Cu 2000, Ni 20 and Pb 10  $\mu\text{g L}^{-1}$ , Zn has no limitations). This is remarkable since Pb was one of the first metals associated with road traffic (e.g. Motto et al., 1970, Laxen and Harrison, 1977) and Pb concentrations in road runoff decreased exponentially in the last 25 years in Europe, which is credited to the Pb phase-out regulations (Kayhanian et al., 2012).

Variations of the metal concentrations during the sampling period are a result of variations in rain intensity and duration, dry periods, wind, traffic and the application of de-icing agents as Barbosa and Hvitved-Jacobsen (1999) and Kayhanian et al. (2012) have already mentioned. For all other metals, even maximum values were below the European threshold values for drinking water, except for some outliers (see supplementary material –S2).

In road runoff, Pb was largely associated with particles (90%), particle-bound Cr, Cu, Ni and Zn made up about 70% and Cd about 50% of the total metal concentration. This is similar to the findings of other authors who analysed dissolved and particle-bound metals in road runoff. This is similar to the findings of Preciado and Li (2006) who determined a particle-bound Pb fraction of 93% and whereas particle-bound Cu and Zn made up about 52% and 75%.

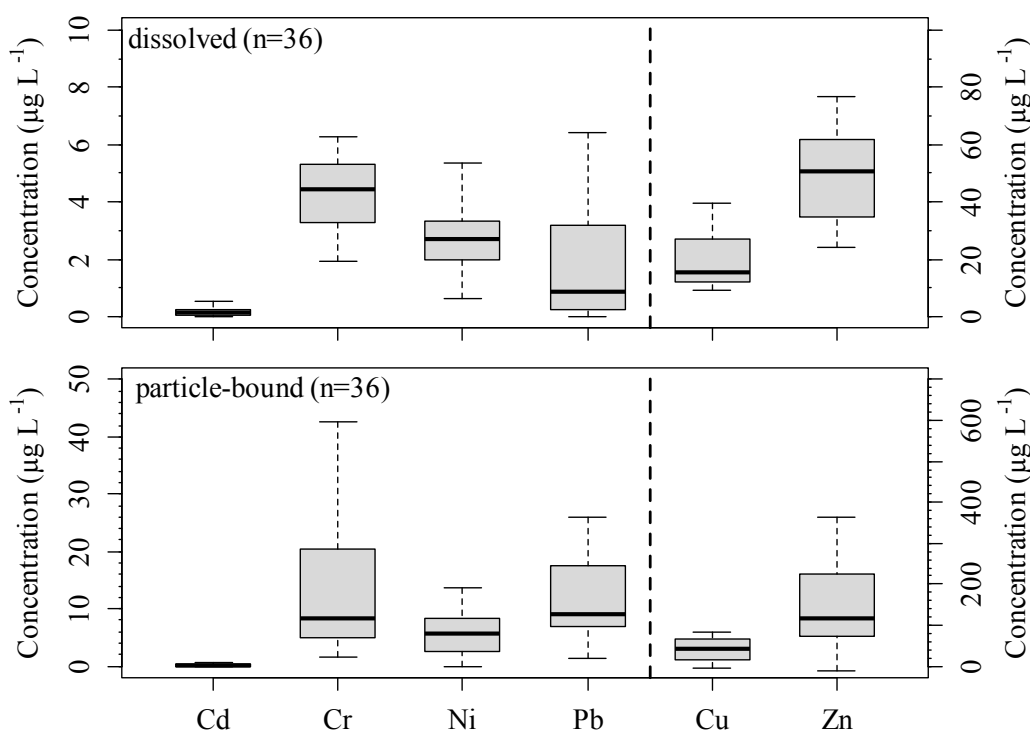

Fig. 4.3: Dissolved (top) and particle-bound (bottom) metal concentrations in road runoff of the A115 (median, min., max., upper and lower quartile; outliers are not displayed). Note: the bold dashed line separates the plot into two different y-scales.

The mean dissolved metal concentrations are within the range observed in other studies; mean total concentrations (dissolved + particle-bound) are lower (Tab. 4.2). The latter is due to the road runoff sampling system selected (runoff lysimeter). Road sediments are not transferred to the sampling vessels and therefore accumulate in the runoff lysimeter. In most literature studies, the sampling systems (e.g. pipes, gullies) also collect the road sediments (Beer et al., 2011; Helmreich et al., 2010). Within one year, a total sediment load of 4.7 kg m<sup>-2</sup> accumulated in the runoff lysimeter. According to Zanders (2005), the accumulation rate of road sediments ranges between 1-36 kg m<sup>-1</sup> a<sup>-1</sup>, depending on the surrounding vegetation and traffic density.

Metal concentrations of the sediments collected are 0.4 (Cd), 45.1 (Cr), 98.1 (Cu), 12.0 (Ni), 19.0 (Pb) and 359.9 (Zn) mg kg<sup>-1</sup> respectively. Taking the sediment concentrations and-loads as well as the corresponding runoff volume into account, the total metal concentrations (dissolved + particle-bound + sediment) in road runoff were considerably higher (Tab. 4.2). Metals in road sediments made up 59% (Ni) – 78% (Cr) of the total metal concentrations in road runoff. Considering the higher total concentrations due to sediment fraction, Cr and Ni also exceed European threshold values for drinking water.



Tab. 4.2: Mean dissolved and total metal concentrations in road runoff determined in comparison with other studies.

	Cd	Cr	Cu	Ni	Pb	Zn
<b>Dissolved concentrations</b>				$\mu\text{g L}^{-1}$		
Beer et al. 2011	0.16	3.8	22.1	4.4	< 0.1	144
Hallberg et al. 2007	0.11	5.4	19.6	3.8	0.1	98.3
Westerlund and Viklander 2006	0.03	-	6.8	1.4	0.3	24.9
This study	0.13	4.4	15.6	2.7	0.8	50.6
<b>Total concentrations</b> (dissolved + particle-bound + sediments)				$\mu\text{g L}^{-1}$		
Beer et al. 2011	0.51	96.8	226.1	35.3	8.4	738
Westerlund and Viklander 2006	0.4	-	80.0	24.7	32.4	307
Helmreich et al. 2010	<0.5	-	155	35	43	592
This study (without sediments)	0.2	12.6	59.0	8.4	9.9	163
This study (including sediments)	0.6	57.9	165.5	20.5	28.6	527

#### 4.3.4. Metals in soil solution

Median dissolved concentrations of Cd, Cu, Pb and Zn in soil solution are highest in the topsoil material (TSM) embankment whereas particle-bound metal concentrations are only highest for Cu (Fig. 4.4). The base course material (BCM) embankment shows the highest particle-bound concentrations of Cr, Ni, Pb and Zn. Median dissolved concentrations of Cd, Cr and Ni are rather low in the soil solution and no significant differences between the embankment constructions were measured. Dissolved metal concentrations in soil solution of all variants are within the range of concentrations at different European highway sites (Werkenthin et al., 2014).

Compared to dissolved concentration in road runoff, dissolved concentration in soil solution are, depending on the metal, often higher. This is contrary to the findings of Piguet et al. (2008) and Blecken et al. (2011) who measured decreasing concentrations (dissolved) for all metals after percolation through an embankment soil. However other authors (e.g. Bäckström, 2003; Ingvertsen et al., 2012b) investigating the retention of dissolved metals infiltration systems in laboratory and field studies determined higher concentrations in soil solution compared to input/runoff concentrations. They attributed the increasing concentrations to low dissolved concentrations in runoff and to a mobilization of metals from soil matrix. Elevated soil matrix concentrations of the TSM (Tab. 4.1) therefore probably cause the relatively high Cu and Pb concentrations in soil solution.

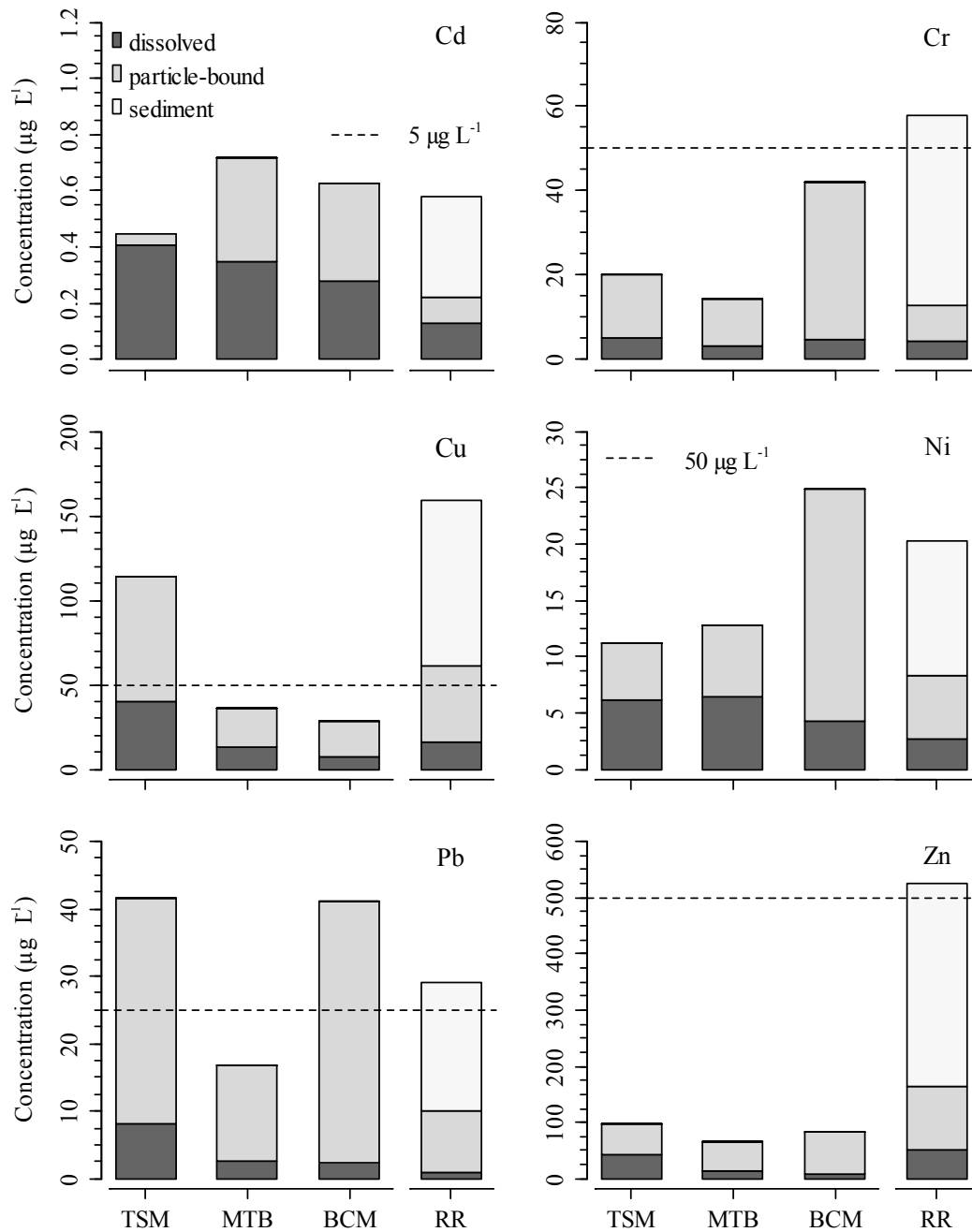

Fig. 4.4: Median dissolved ( $n=12$ ), particle-bound ( $n=12$ ) and sediment ( $n=1$ ) metal concentrations in soil solution of different embankments (TSM, MTB, BCM) and in the infiltrating road runoff (RR). The dashed line marks the trigger values of the BBodSchV (1999).

The percentage of particle-bound metals in soil solution ranges between 9% (Cd; TSM) and 94% (Pb; BCM). For the majority of the particle-bound metals the ratio is higher than 50%, which underlines the importance of this fraction for metal transport in embankment soils. The high infiltration rates in embankment soils promote preferential flow and consequently also metal mobilisation and transport (Roulier et al., 2008; Ingvertsen et al., 2012b).

This peculiarity could also be the reason for the relatively high ratio of particle-bound metals in soil solution. However, a systematic difference between the two gravel (BCM and MTB) and reference embankment (TSM) could not be detected. In Germany, there is a legislation defining trigger values for the transfer of dissolved metals via soil solution into the groundwater in the form of the BBodSchV (1999). Considering these trigger values (Cd 5; Cr 50; Cu 50; Ni 50; Pb 25; Zn 500 g L<sup>-1</sup>) no instances where concentrations exceeded these values were observed at depths of 30 or 20 cm.

In many studies on metal retention from road runoff (e.g. bioretention areas) the removal rate is a parameter to assess the retention efficiency of the infiltration system (Davis et al., 2003; Chapman and Horner, 2010; LeFevre et al., 2015). Retention rates of Cd, Cu, Pb and Zn in most of these studies was above 50% and typically 90% or greater. These purification rates are not achieved by the embankment soils, with some limitations for Zn and Cu (Tab. 4.3). This underlines the difference between embankments that are designed for road safety and bioretention systems which primarily intend to purify the infiltrating runoff. In section 4.3.4 - loads - the mean metal concentrations of soil solution and road runoff are set in relation to the corresponding water volumes in order to extend the load reduction discussion.

Tab. 4.3: Metal reduction of the different embankment lysimeters. Negative reduction indicates a metal release of the embankment materials.

	Cd	Cr	Cu	Ni	Pb	Zn
	R (%)					
<b>TSM</b>	15	66	28	45	-43	82
<b>MTB</b>	-24	75	78	37	42	87
<b>BCM</b>	-8	28	82	-22	-42	84

### Annual course of concentrations

The course of total Cu and Pb concentrations in the embankment lysimeters as well as in road runoff are shown in Figure 4.5 and can be seen as an example for the other metals analysed. Total metal concentrations in soil solution of the embankment did not directly correlate with concentrations in road runoff. This confirms the earlier assumption that leaching from soil matrix influences concentrations in soil solution leading to higher concentrations than in road runoff.

In a study on groundwater pollution Mikkelsen et al. (1997) stated that sediments from runoff play an important role both as a source and sorbent for pollutants. In particular, temporary low runoff concentrations may lead to a mobilisation of pollutants from roadside soils (Bäckström, 2003).

During the course of the year, total (dissolved + particle-bound) metal concentrations in soil solution varied significantly in all embankments. Soil solution concentrations may correlate with weather conditions, namely temperature, dry periods and intensive rain events. Due to the special hydrological conditions in embankment soils, even light rainfall events can lead to a total exchange of the soil solution (Kluge et al., 2014). This, in turn means that high infiltration rates could prevent equilibration between soil matrix and soil solution leading to varying concentrations in lysimeter discharge.

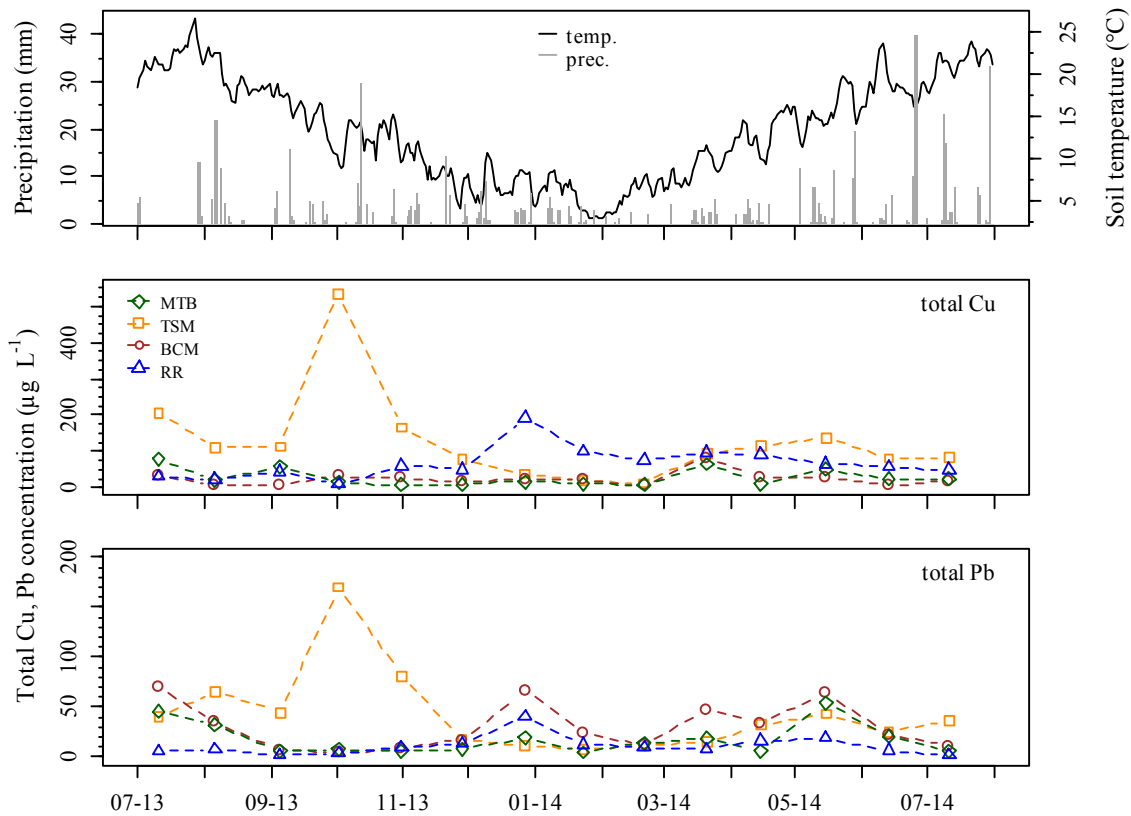

Fig. 4.5: Total Cu and Pb concentrations in soil solution of the embankment lysimeter (MTB, TSM, BCM) and road runoff (RR) as well as precipitation and mean soil temperature.

Total concentrations of the MTB and BCM embankment are mostly in a similar order of magnitude, whereas concentrations of the TSM are elevated at several sampling dates. It can be observed that, the Cu and Pb concentrations of the TSM embankment are increased from late spring to early autumn and decrease during the winter months. The higher soil temperature during this period (Fig. 4.5) may have caused an elevated decomposition of soil organic material by microorganisms, increasing the dissolved organic carbon (DOC) concentration in soil solution. This in turn enhances the solubility of metals and in particular those of Cu and Pb due to complexation (Weng et al. 2002; Bradl, 2004, Hjortenkrans et al., 2008).

The high concentrations of the TSM in October 2013 could result from a combination of favourable environmental conditions, namely soil moisture and the input from litter, which is characteristic for this season. Furthermore, the drop in soil temperature before sampling in October 2013 could have led to a change in microorganism community increasing the release of DOC and thus Cu concentrations.

The pH in soil solution of the different embankments ranged between 8.9 and 6.8 during the measuring period. It was always above the critical pH-value from which metal mobility significantly increases (Alloway, 2012). Soil pH therefore played only a minor role in terms of metal mobility in the different embankment lysimeters.

### Metal loads

The highest metal input load was calculated for Zn followed by Cu, Cr, Pb, Ni und Cd (Fig. 4.6). For all variants and metals the metal input was higher than the metal output. The BCM lysimeter had the highest metal outputs except for Cu that was highest in the TSM lysimeter. The lowest output for Cu, Pb and Zn was determined in the MTB lysimeter, Ni and Cd output was lowest in the TSM lysimeter.

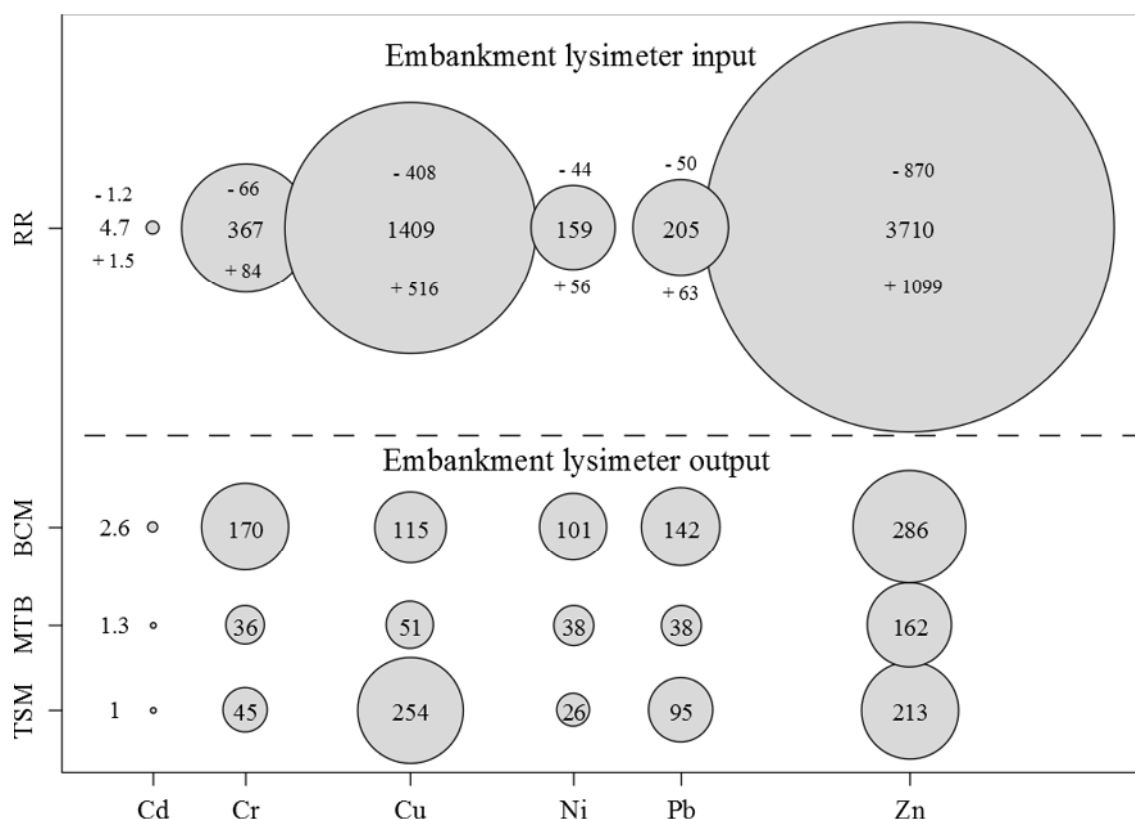

Fig. 4.6: Annual metal output loads exported via soil solution from the embankment lysimeters ( $\text{mg m}^{-2} \text{a}^{-1}$ ) and annual metal loads introduced via road runoff (input). The radius of the circles is proportional to the load of a specific metal. For the road runoff the variability due to different runoff volumes was also calculated ( $\pm$ ).

In Germany, the BBodSchV (1999) defines limit values for maximum metal loads (Cd 0.6, Cr 30, Cu 36, Ni 10, Pb 40, Zn 120 mg m<sup>-2</sup> a<sup>-1</sup>). The metal loads from all variants exceed these limit values. This underlines that even though the metal concentrations in soil solution are currently not problematic from the legislators' point of view, considerable metal loads may be transferred to deeper soil layers due to the infiltration of road runoff into the embankment. This problem has already been stated by Kocher and Wessolek (2002) who calculated average metal loads for different highway embankment sites in Germany, using a water balance model and measured soil solution concentrations (Cd 1.1, Cr 12, Cu 68, Ni 14, Pb 4, Zn 273 mg m<sup>-2</sup> a<sup>-1</sup>).

The decisive factor for the highest metal outputs of the BCM lysimeter is the higher groundwater recharge rate of the BCM (4,100 mm) compared to 2,200 and 2,000 mm for TSM and MTB. In contrast a low hydraulic conductivity of the embankment soils could lead to lower metal loads because the road runoff infiltrates into a larger area (slope and ditch), as the ratio of surface runoff to soil solution from the MTB lysimeter shows (Fig. 4.2). However the comparability of embankment lysimeter metal outputs is partly limited due to uncertainty respectively the variability of the incoming runoff volumes (sec. 4.3.2).

#### 4.4. Conclusions

We could show that the hydraulic loadings on the embankment may vary widely on a small scale. Over 50% of the metals introduced to the roadside embankment soil via road runoff are associated with sediments. Sediment retention from road runoff is therefore a decisive factor for metal immobilization in embankment soils. However, sediment retention potentially leads to a significant metal accumulation in this area. Equilibration between dissolved metals from road runoff and the solid phase of the embankment plays a minor role in terms of increased matrix concentrations. Elevated concentrations in soil solution are mainly caused by mobilization of metals associated with soil matrix or sediments.

With respect to the German trigger values for soil solution, no increased risk of groundwater pollution results from the construction of stable embankments. Compared to the non-stable reference (conventional embankment material) dissolved metal concentrations in soil solution of gravel highway embankments are not significantly higher. Even though total concentrations were, depending on the metal, more than twice as high as the dissolved concentrations, there is no legal basis to evaluate the particle-bound metal fraction in soil solution. Nonetheless, this is an important finding in terms of a risk assessment. Many studies dealing with metal pollution in roadside soils use different extract methods to estimate the potential of groundwater pollution, particulate metal transport is not taken into account.

However, the results of this study clearly show that an evaluation based on soil matrix concentrations underestimates total metal concentrations in soil solution and thus the toxicological effects.

Although determined metal concentrations were not problematic the elevated infiltration rates beside the road may degrade the groundwater aquifer. Beneath the embankment very high groundwater recharge rates occur, which are up to 22 times higher compared to natural conditions. This facilitates the transfer of considerable metal loads into deeper soil layers and potentially also into the groundwater, which is especially important in regions with a shallow groundwater table. One possibility to counteract this problem is to reduce the infiltration capacity of the embankment soil and thus increase the infiltration-area of the road runoff. In terms of future stormwater management practice, environmental policies and research we suggest to put a stronger focus on particulate metal transport and metal loads.

### **Acknowledgements**

We thank the Federal Highway Research Institute (BAST) for financing this research project. We are also grateful to Steffen Trinks and Maik Schüßler for the support during study site construction as well as all colleagues at the Department of Ecology, Soil Conservation, Technische Universität Berlin for scientific discussion and laboratory analyses.





## Part III: Synthesis

## 5. Synthesis

This thesis deals with the consequences of a diffuse infiltration from runoff on metal concentrations in the adjacent embankment soil and soil solution. In this chapter the main outcomes of the research work performed are presented and synthesized in order to give an overall conclusion and to point out upcoming research questions. Furthermore challenges and recommendations for future embankment constructions and highway runoff management are deduced from the obtained results.

### 5.1. Metals in roadside soils

The review of numerous studies shows that road construction and traffic are affecting the metal content of the surrounding soils significantly. From the synthesis of the collected data, some typical soil contamination patterns can be derived:

The road traffic-induced metal emissions usually lead to elevated concentrations in the topsoil layer (0–<5 cm) of the first 5 m beside the road. The mean concentrations in this area were 0.7(Cd), 28(Cr), 48(Cu), 25(Ni), 106(Pb) and 179(Zn) mg kg<sup>-1</sup>. At this distance, road runoff infiltration is of major importance for the increased metal input. Despite the large variation of study site conditions in the investigations reviewed, the influence of road traffic on soil contamination generally decreases with increasing soil depth or distance from the road, however there are always some exceptions. Furthermore a positive correlation between traffic intensity and soil metal concentrations exists except for Pb, which could be due to different lead phase out regulations.

The metal concentrations of the embankment soils analysed at the AVUS highway follow the same patterns that were determined in the literature review, with certain limitations for Zn and Cd. An enhanced infiltration of road runoff at 2.5 distance probably increased Cd and Zn leaching from the embankment soil at the AVUS site leading to lower soil matrix concentrations (compared to 5 and 10 m). Overall metal concentrations of the AVUS embankment are strongly elevated, with concentrations up to thirty times higher than the background levels at 800 meter distance from the road (3.3(Cd) and 74(Cu) mg L<sup>-1</sup>). The median Cd, Cu, Pb and Zn concentrations exceeded the precautionary values of the BBodSchV (1999) for any depth and distance investigated at the highway site. However the precautionary values are not legally binding in this area since the analysed soils are a part of the road structure (embankment, slope and ditch). The comparison thus only serves for the evaluation of the degree of contamination.

The conducted lysimeter studies show that more than half of the metals introduced to the roadside embankment soils via road runoff are associated with sediments. Sediment retardation is therefore a decisive factor for increased metal concentrations in the road adjacent soils.

Furthermore this particle retention as well as the deposition of road dust changes the physico-chemical properties of the soil as the comparison of embankment and reference soil at the AVUS site demonstrates. The investigated topsoil layer of the old embankment was probably even, to some extent, generated by particle and sediment depositions. This explains the higher pH, CaCO<sub>3</sub> and clay content of the embankment soil compared to the reference soil. Presumably the topsoil layer from most of the studies reviewed also arose from sediment deposition (provided that it was not removed due to road maintenance activities). The negative correlation between distance to the road and soil pH determined in the literature review also supports this assumption. Adsorption experiments show, that the old embankment topsoil layer has a higher metal retardation capacity than the reference soil. Retardation capacity of roadside soils thus increased during operational time due to particle and sediment accumulation.

## 5.2. Soil solution

The European data synthesis shows that only a few authors have successfully analysed and published data on metal concentrations in soil solution of roadside soils. However the data synthesis of the studies available demonstrates that metal concentration patterns in soil solution differ from the concentration patterns in soil matrix. In contrast to metal concentrations in the solid phase, solute concentrations often increase with increasing distance to the road (up to 10 m). The elevated concentrations at this distance (10 m) are probably caused by a combination of elevated matrix concentrations, a lower pH (compared to the soil directly at the road edge) and lower percolation rates that are usually not affected by runoff or splashing water. The synthesized mean metal concentrations exceeded the trigger values of the BBodSchV (1999) only sporadically. Overall, the risk of groundwater pollution due to road runoff infiltration seems to be relatively low at the reviewed study sites.

Metal concentrations in soil solution of the AVUS embankment site are however elevated, some (Pb, Cu and Ni) are even higher than solute metal concentrations in highway runoff. The infiltrating water is probably enriched with metals, most likely due to leaching from soil matrix and deposited particles/sediments, leading to increased soil solution concentrations. Thus the elevated metal concentrations in soil solution at the AVUS site are not a direct result of road runoff but rather of elevated concentrations in the solid phase of the embankment soils. The results of the lysimeter study performed with “new embankment soils” largely supports this assumption.

The high electrical conductivity of the soil solution collected at the AVUS site indicates that deicing agents were applied during the sampling period (Jan. – Mar. 2008) which are known to increase metal leaching from embankment soil matrix. Concentrations in the soil solution of the AVUS embankments are thus probably higher than the mean annual concentrations. This phenomenon is certainly one reason why mean dissolved Cu and Pb concentrations exceed the trigger values of the BBodSchV (1999) at the AVUS site. Even though the trigger values are not legally binding in the applied sampling depth, they can again serve as an indicator for the degree of contamination of embankment soils.

The mean dissolved metal concentrations in soil solution of the newly constructed embankments are all below the trigger values ranging from 0.28-0.38(Cd), 3.4-5.1(Cr), 8-40(Cu), 4.3-6.5(Ni), 2.4-8.1(Pb) and 9.5-42(Zn)  $\mu\text{g L}^{-1}$ . The investigations also show that metal concentrations in embankments constructed according to the new requirements are not significantly higher compared to non-stable embankments. Consequently the diffuse infiltration of road runoff into stable embankments does not increase the risk of groundwater contamination (with respect to the current trigger values for soil solution). Furthermore the measurements at the lysimeter site show that metal concentrations, especially those of Pb and Cu, may temporarily increase due to increased microbial activity.

Particle-bound metals from road runoff are retained to a great extent in embankment soils at the AVUS highway which have been present for extended periods of time. Nonetheless total Pb and Cd concentrations in soil solution are about twice as high as dissolved concentrations. For Cr, Cu, Ni and Zn, the particle-bound shares were significantly lower. In the lysimeter studies, the majority of the metals have a considerably higher ratio of particle-bound metals in soil solution (mostly more than 50%), which could be a result of the relatively short operating time of the embankment lysimeters. This underlines the importance of the particulate metal transport in roadside soils, especially in newly constructed stable embankments. Nevertheless, there is currently no legal basis to evaluate and compare particle bound metal concentrations in soil solution for various study sites.

In the search for a suitable laboratory method to estimate soil solution concentrations in field, the batch S4 experiment and the adsorption isotherms had an acceptable level of agreement with data from field measurements at the AVUS site. The soil solution extracts (SSE), proposed by the BBodSchV (1999) did not lead to comparable results. Especially with regards to current trigger values, the S4 experiment constitutes a simple alternative to field studies in terms of a risk assessment. However, only dissolved metal concentrations can be established in the laboratory experiments performed; neglecting particulate transport. This can lead to an underestimation of the effective (total) metal concentrations in soil solution and thus the potential toxicological effects.

### 5.3. Metal loads

The mean annual volume of road runoff for one highway meter amounts to about 12,300 mm at the lysimeter site, however this volume can vary widely due to different catchment areas. Along with the infiltrating highway runoff considerable sediment and metal loads are introduced into the embankment soils. At the lysimeter site, a mean annual sediment load of 4.7 kg m<sup>-2</sup> was determined. The metal loads introduced to the adjacent soils vary widely ranging from 4.7 mg m<sup>-2</sup> a<sup>-1</sup> for Cd up to 3710 mg m<sup>-2</sup> a<sup>-1</sup> for Zn.

The high amount of infiltrating road runoff increases the groundwater recharge rate beneath the embankment soils. Compared to the natural recharge in the surrounding area (180 mm a<sup>-1</sup>), it is increased by up to 22 times (about 4,100 mm a<sup>-1</sup>). As a consequence, considerable metal loads might be transferred into deeper soil layers in this area. The highest metal loads (except for Cu) occur beneath the embankment material with the largest infiltration rate (BCM). Although metal concentrations in soil solution are not problematic from the legislators' point of view, all metal loads determined at the newly constructed embankment lysimeters exceeded the limit values for metal loads defined in the BBodSchV (1999). In this respect it is clear that further efforts are needed to reduce the metal loads resulting from runoff infiltration, even though the BBodSchV (1999) is not legally binding for embankment soils.

### 5.4. Overall conclusions

- Highest metal concentrations in European roadside soils were determined in the top soil layer at the first 5 m beside the road.
- Elevated metal concentrations in soil solution are not a direct result of road runoff but rather of elevated concentrations in soil matrix.
- Particulate metal transport is of importance in roadside soils, however currently no legal basis exists for evaluation.
- Sediment retention in embankment soils is the decisive factor for runoff depuration. This can increase the metal retention capacity during operational time.
- Stable embankment design does not lead to higher metal concentrations in soil solution.
- Groundwater recharge rates are strongly increased compared to natural conditions which leads to a considerable transfer of metal loads.
- From the environmental point of view the diffuse infiltration of road runoff constitutes an appropriate means in terms of highway runoff management.

## 5.5. Challenges and recommendations for future embankment construction practice

The management and treatment of runoff from sealed surfaces will continue to play an important role in terms of environmental protection, particularly in the context of increasing land consumption. The studies performed show that the diffuse infiltration of road runoff from highways into stable embankments meets the objectives of an environmentally sound road dewatering as defined in the RAS-Ew (2005). Most importantly this includes the return of the possibly highest proportion of the road runoff to the natural local water cycle without degrading the existing water body. It should therefore continue to play an important role in terms of highway runoff management practice. The increasing trend towards a channelled treatment of road runoff is rather critical from the environmental point of view since this measure disturbs the local water balance, potentially degrades the receiving waters, leads to the problem of waste (contaminated particles/sediments) and is associated with an additional construction effort.

To further reduce negative impacts of diffuse runoff infiltration some optimisation potential in the treatment performance of stable embankment soils still exists. As the investigations performed show, large metal loads are occurring beneath the embankment soils, constituting a potential risk for groundwater quality. One possibility to counteract this problem would be to reduce the hydraulic conductivity of the embankment structures. This would increase the infiltration area of the road runoff, especially within the area of the slope and ditch which in turn would reduce the groundwater recharge rate directly beneath the embankment. Most of the material listed in the ZtVE-StB (2009) have a relatively low infiltration rate and thus, already meet this requirement. However one variant which is often used in practice, the so called “gravel lawn”, is not defined with sufficient precision so as to ensure a low hydraulic conductivity after installation. Therefore the term “gravel lawn” needs to be defined more accurately in the relevant directive (ZtVE-StB, 2009). In combination with the findings of Koukoulidou et al. (2014), who systematically investigated the influence of fine soil material ( $<0.063$  mm) on the bearing capacity of embankment materials, it is recommended to specify a minimum share of 5 M%. In this way it is possible to meet the requirements regarding road safety and additionally, to enhance metal retention in the embankment soils.

It is a widely held view in Germany that the application of topsoil material significantly increases the pollutant retention capability of embankment soils, which is also reflected in the relevant regulations (RAS-Ew, 2005; ZtVE-StB, 2009). The present findings however demonstrate that the use of topsoil does not necessarily lead to lower metal concentrations in the soil solution.

Due to the special hydraulic conditions and pollution loadings influencing the embankment soils, the opposite may even be true. The use of topsoil material for embankment constructions is therefore not necessarily required from the environmental point of view, especially when considering that the accumulation of sediments and particles leads to the development of a new, organic topsoil layer.

The field investigations conducted show that a large proportion of the metals associated with sediments and particles is retained. However, total metal concentrations in soil solution are often more than twice as high as dissolved concentrations. Future embankment constructions should therefore aim to provide the highest possible particle retention capacity in order to enhance metal retention. In the same vein, prescribing a minimum share of fine soil material, as previously mentioned, is a measure that could also particle retention capacity improve of embankment soils. On the one hand this would reduce the number of coarse and medium pores, which are important for particle transport and on the other this would lead to lower flow velocities and thereby decrease vertical particle transport. Particle-bound metal transport is also a challenge for future environmental legislation. A legal basis concerning total metal concentrations in soil solution should be adopted in order to provide a foundation for common evaluation. This is necessary to avoid negative consequences for soil and groundwater as far as possible.

Another possibility to improve the metal retention from highway runoff is channelled road drainage with a subsequent technical treatment. Particle sedimentation in detention ponds for example, would be an efficient way to remove a high proportion of pollutants from road runoff. The pre-cleaned effluent then could be transferred into a semi-technical infiltration facility. However, this would demand considerable extra construction and financial effort with the result that a system which generally proved to fulfil the environmental requirements is slightly improved. Thus a channelled, technical runoff treatment should be applied only in exceptional cases such as groundwater protection areas as prescribed in the RAS-Ew (2005) and RistWag (2002).

To reduce the environmental impact of highway traffic it is also necessary to improve road maintenance activities, namely the removal of the topsoil layer (which is thought to ensure a reliable road dewatering). This measure leads, among other aspects, to the elimination of an important filter layer. One measure to improve the maintenance practice could be to preserve a small layer of the new topsoil in order to maintain its important filtering properties. In this way the potential for an increased metal mobilization after road maintenance activities can be reduced. Another measure could be to increase the maintenance intervals and thus remove a potential contaminant source from the embankment area.

In order to save natural resources and to reduce the amount waste, the Federal Highway Research Institute (BAST) of Germany performed a very comprehensive study on the contamination and the recycling potential of the removed topsoil material (Kocher et al., 2008). Reuse of the removed topsoil material for slope and ditch construction could represent a possibility for saving natural resources. However the materials used must meet the limit values of the LAGA M20 (2004). Thus, it is likely that the topsoil material removed from highway sites cannot be recycled, however material from secondary roads could be suitable for re-utilisation.

## **5.6. Future research questions**

In the lysimeter study, transport and retardation of metals was observed only in newly constructed embankment soils. However, due to the permanent material input from dust deposition and road derived sediments, the properties of the embankment soil will change over time, leading to the development of a completely new anthropogenic soil layer. It should therefore be an aim of future studies to investigate the change of metal retention capacity from embankment soils over time. The investigation of this question is particularly important in order to improve the prediction of the long-term development of metal leaching in highway embankments and the resulting risk of groundwater degradation.

Furthermore, there is a need for research regarding particle-bound metal transport in roadside embankment soils. Although this is an important issue in terms of a risk assessment, there has not yet been sufficient investigation into to which depths particle-bound metals are transferred. Usually the particle-bound transport into deeper soil layers is not significant because of the limiting physical conditions in soil. However, due to the high infiltration rates and high flow velocities occurring in embankment soils, it can be expected that particle-bound metals can reach higher soil depth than under normal conditions. In this context it is also important to investigate the preferential flow characteristics of roadside soils - particularly those of gravel embankment soils- in more detail. It is essential to understand these mechanisms in order to more realistically assess the long-term ecological risk resulting from diffuse runoff infiltration.

To reduce the degree of contamination in the roadside environment with respect to embankment soils, it is also essential to decrease the emissions of highway traffic. With regards to the elevated concentrations in soil solution it is particularly important to reduce the Cu emissions from traffic activities. According to the EU-Commission, abrasion from brake lining is the major source for Cu emissions. The determination and implementation of other, suitable materials for brake linings should be supported in future.



Other metals such as Sb, Se and V recently received much attention in international investigations dealing with the contamination of roadside soils. In Germany however there is a lack of studies on the concentrations and the mobility of these elements in embankment soils. As a consequence, it is important to promote renewed research within in this subject area.

Future investigations should also focus on analysing the impacts of diffuse runoff infiltration using groundwater monitoring wells. At the moment hardly any internationally published studies exist that performed measurements in the groundwater body next to highway sites. However this is a central issue, especially when considering the high infiltration rates and metal loads occurring in the road adjacent soils.

As the lysimeter studies showed, a significant share of the road runoff does not infiltrate in the first 1.5 m when using a gravel-soil mixture with a certain share of fine soil for embankment construction. If the recommendations in this thesis (definition of minimum share of fine soil material) are implemented, an enhanced surface runoff across the embankment can be expected which will mainly infiltrate into the slope and ditch. Therefore it is also important to determine the in- and output rates of metals in this zone, especially since the ditch is levelled considerably lower than the embankment. Thus, further investigations and research should be undertaken in this area of the roadside environment.

## 6. References

- Alloway B.J., editor 2012. Heavy metals in soils: trace metals and metalloids in soils and their bioavailability. Environmental Pollution, Springer; p. 631
- Akbar, K.F., Hale, W.H., Headley, A.D., Athar, M., 2006. Heavy metal contamination of roadside soils of Northern England. Soil and Water Research 1, 158-163.
- Amrhein, C., Strong, J.E., Mosher, P.A., 1992. Effect of deicing salts on metal and organic-matter mobilization in roadside soils. Environmental Science & Technology 26, 703-709.
- Arslan, H., Gizir, A.M., 2006. Heavy-metal content of roadside soil in Mersin, Turkey. Fresenius Environmental Bulletin 15, 15-20.
- Bäckström, M., 2003. Grassed swales for stormwater pollution control during rain and snowmelt. Water Science and Technology 48, 123-132.
- Bäckström, M., Karlsson, S., Bäckman, L., Folkesson, L., Lind, B., 2004. Mobilisation of heavy metals by deicing salts in a roadside environment. Water Research 38, 720-732.
- Bakirdere, S., Yaman, M., 2008. Determination of lead, cadmium and copper in roadside soil and plants in Elazig, Turkey. Environmental Monitoring and Assessment 136, 401-410.
- Barbosa, A.E., Hvitved-Jacobsen, T., 1999. Highway runoff and potential for removal of heavy metals in an infiltration pond in Portugal. Science of the Total Environment 235, 151-159.
- Bartlett, R., James, B., 1980. Studying dried, stored soil samples - Some pitfalls. Soil Science Society of America Journal 44, 721-724.
- Bayliss, D., 1990. Orbital motorways: proceedings of the conference organized by the Institution of Civil Engineers and held in Stratford-upon-Avon on 24-26 April 1990. Thomas Telford, 1990.
- BBodSchG - Gesetz zum Schutz vor schädlichen Bodenveränderungen und zur Sanierung von Altlasten vom 17. März 1998 (BGB.I.S. 502): in German; 1998.
- BBodSchV - Bundes-Bodenschutz- und Altlastenverordnung vom 12. Juli 1999 (BGBl. I S. 1554): in German; 1999.
- Beer, F., Surkus, B., Kocher, B., 2011. Element input into roadside soils-measuring period 2008/2009. Report No. V 209 Federal Highway Research Institute (BAST), Germany, p. 40 (in German).
- Blecken, G.-T., Marsalek, J., Viklander, M., 2011. Laboratory study of stormwater biofiltration in low temperatures: total and dissolved metal removals and fates. Water Air and Soil Pollution 219, 303-317.
- Blecken, G.-T., Zinger, Y., Deletic, A., Fletcher, T.D., Viklander, M., 2009. Influence of intermittent wetting and drying conditions on heavy metal removal by stormwater biofilters. Water Research 43, 4590-4598.
- Boivin, P., Saade, M., Pfeiffer, H.R., Hammecker, C., Degoumois, Y., 2008. Depuration of highway runoff water into grass-covered embankments. Environmental Technology 29, 709-720.

- Bradl, H.B., 2004. Adsorption of heavy metal ions on soils and soils constituents. *Journal of Colloid and Interface Science* 277, 1-18.
- Bruemmer, G.W., Gerth, J., Herms, U., 1986. Heavy metal species, mobility and availability in soils. *Zeitschrift Fur Pflanzenernahrung Und Bodenkunde* 149, 382-398.
- Carlosena, A., Andrade, J.M., Prada, D., 1998. Searching for heavy metals grouping roadside soils as a function of motorized traffic influence. *Talanta* 47, 753-767.
- Carrero, J.A., Arrizabalaga, I., Bustamante, J., Goienaga, N., Arana, G., Madariaga, J.M., 2013. Diagnosing the traffic impact on roadside soils through a multianalytical data analysis of the concentration profiles of traffic-related elements. *Science of the Total Environment* 458, 427-434.
- Chapman, C., Horner, R.R., 2010. Performance Assessment of a Street-Drainage Bioretention System. *Water Environment Research* 82, 109-119.
- Christoforidis, A., Stamatis, N., 2009. Heavy metal contamination in street dust and roadside soil along the major national road in Kavala's region, Greece. *Geoderma* 151, 257-263.
- Clark, S.E., Pitt, R., Field, R., 2010. Groundwater contamination potential from infiltration of urban stormwater runoff. In: Chang, N.-B. (Ed.), *Effects of Urbanization on Groundwater: An Engineering Case-Based Approach for Sustainable Development*, American Society of Civil Engineers.
- Delay, M., Lager, T., Schulz, H.D., Frimmel, F.H., 2007. Comparison of leaching tests to determine and quantify the release of inorganic contaminants in demolition waste. *Waste Management* 27, 248-255.
- Deska, J., Bombik, A., Marciniuk-Kluska, A., Rymuza, K., 2011. Trends in Lead and Cadmium Content in Soils Adjacent to European Highway E30. *Polish Journal of Environmental Studies* 20, 317-325.
- Dierkes, C., Geiger, W.F., 1999. Pollution retention capabilities of roadside soils. *Water Science and Technology* 39, 201-208.
- DIN 38414-4. German standard methods for the examination of water, waste water and sludge; sludge and sediments (group S); determination of leachability by water (S 4). Berlin: German Institute for Standardization, 1984.
- DIN ISO 11466. Soil quality—Extraction of trace elements soluble in aqua regia. Berlin: German Institute for Standardization; 1997.
- DIN EN ISO 15587-2. Water quality - Digestion for the determination of elements in water – Part 2: Nitric acid digestion. Berlin: German Institute for Standardization; 2002.
- DIN EN ISO 17294-2. Water quality - Application of inductively coupled plasma mass spectrometry (ICP-MS) - Part 2: Determination of 62 elements. Berlin: German Institute for Standardization; 2005.
- DIN V 19735. Soil Quality - Derivation Of Element Concentrations In Soil Water From Ammoniumnitrate Extractable Contents Or Eluate Contents. Berlin: German Institute for Standardization, 1999.
- DIN V 19736. Soil quality-determination of concentrations of organic substances in the soil water. Berlin: German Institute for Standardization, 1998.

- Directive 2000/60/EC. Directive of the European Parliament and of the Council of 23 October 2000 establishing a framework for Community action in the field of water policy. Official Journal of the European Communities, 15, 1-5.
- Directive, EC Council, 1998. 98/83/EC. The quality of water intended for human consumption. Official Journal of the European Communities, L 330, 05-12.
- Elliott, H.A., Lieberati, M.R., Huang, C.P., 1986. Competitive adsorption of heavy-metals by soils. *Journal of Environmental Quality* 15, 214-219.
- El-Mufleh, A., Bechet, B., Ruban, V., Legret, M., Clozel, B., Barraud, S., Gonzalez-Merchan, C., Bedell, J.P., Delolme, C., 2014. Review on physical and chemical characterizations of contaminated sediments from urban stormwater infiltration basins within the framework of the French observatory for urban hydrology (SOERE URBIS). *Environmental Science and Pollution Research* 21, 5329-5346.
- Enell, A., Reichenberg, F., Warfvinge, P., Ewald, G., 2004. A column method for determination of leaching of polycyclic aromatic hydrocarbons from aged contaminated soil. *Chemosphere* 54, 707-715.
- FAO. IUSS Working Group, W. R. B., 2006. World reference base for soil resources. *World Soil Resources Report*, 103.
- Fitschen, A., Nordmann, H., 2012. Traffic development on federal highways 2010. Report No. V 230. Federal Highway Research Institute (BAST), Germany, p. 264 (in German).
- Folkeson, L., Bækken, T., Brenčič, M., Dawson, A., Frančoiš, D., Kuřimská, P., Leitão, T., Ličbinský, R., Vojtěšek, M., 2009. Sources and fate of water contaminants in roads. In: Dawson, A. (Ed.), *Water in Road Structures*, Springer Netherlands.
- Gamst, J., Kjeldsen, P., Christensen, T.H., 2007. Determination of solute organic concentration in contaminated soils using a chemical-equilibrium soil column system. *Water Air and Soil Pollution* 183, 377-389.
- Garcia, R., Maiz, I., Millan, E., 1996. Heavy metal contamination analysis of roadsoils and grasses from Gipuzkoa (Spain). *Environmental Technology* 17, 763-770.
- Garrido, F., Helmhart, M., 2012. Lead and soil properties distributions in a roadside soil: Effect of preferential flow paths. *Geoderma* 170, 305-313.
- Göbel, P., Dierkes, C., Coldewey, W.C., 2007. Storm water runoff concentration matrix for urban areas. *Journal of Contaminant Hydrology* 91, 26-42.
- Golwer, A., 1991. Contamination of soils and groundwater through traffic routes (in German). *Forum Städte-Hygiene* 42 (5), 266-275.
- Goyer, R. A., Clarkson, T. W., 1996. Toxic effects of metals. *Casarett & Doull's Toxicology. The Basic Science of Poisons*, Fifth Edition, Klaassen, C.D. (Ed). McGraw-Hill Health Professions Division, ISBN, 71054766.
- Granato, G. E., Church, P. E., Stone, V. J., 1995. Mobilization of major and trace constituents of highway runoff in groundwater potentially caused by deicing chemical migration. *Transportation Research Record*, 1483, 92-104.

- Green, S.M., Machin, R., Cresser, M.S., 2009. Does road salting induce or ameliorate DOC mobilisation from roadside soils to surface waters in the long term?. *Environmental Monitoring and Assessment* 153, 435-448.
- Grigalaviciene, I., Rutkoviene, V., Marozas, V., 2005. The accumulation of heavy metals Pb, Cu and Cd at roadside forest soil. *Polish Journal of Environmental Studies* 14, 109-115.
- Grossman, J., Udluft, P., 1991. The extraction of soil-water by the suction-cup method - A review. *Journal of Soil Science* 42, 83-93.
- Haala, M.-L., Helvi, H., Harri, R., 2004. Heavy metals in roadside soils. *Proceedings of the Estonian Academy of Sciences, Chemistry*. Vol. 53. No. 4. Estonian Academy Publishers, 2004. 53, 182-200.
- Hagner, C., 2000. European regulations to reduce lead emissions from automobiles - did they have an economic impact on the German gasoline and automobile markets?. *Regional Environmental Change* 1, 135-151.
- Hallberg, M., Renman, G., Lundbom, T., 2007. Seasonal variations of ten metals in highway runoff and their partition between dissolved and particulate matter. *Water Air and Soil Pollution* 181, 183-191.
- Harrison, R.M., Tilling, R., Romero, M.S.C., Harrad, S., Jarvis, K., 2003. A study of trace metals and polycyclic aromatic hydrocarbons in the roadside environment. *Atmospheric Environment* 37, 2391-2402.
- Harrison, R., R.M., Johnston, P, W.R., Ralph, J.C., Wilson, S.J., 1985. The budget of lead, copper and cadmium for a major highway. *Science of the Total Environment* 46, 137-145.
- Hatt, B.E., Fletcher, T.D., Deletic, A., 2007. Treatment performance of gravel filter media: Implications for design and application of stormwater infiltration systems. *Water Research* 41, 2513-2524.
- He, Y., Zhang, G.-L., 2009. Historical record of black carbon in urban soils and its environmental implications. *Environmental Pollution* 157, 2684-2688.
- Helmreich, B., Hilliges, R., Schriewer, A., Horn, H., 2010. Runoff pollutants of a highly trafficked urban road - Correlation analysis and seasonal influences. *Chemosphere* 80, 991-997.
- Hilliges, R., Schriewer, A., Helmreich, B., 2013. A three-stage treatment system for highly polluted urban road runoff. *Journal of environmental management* 128, 306-312.
- Hjortenkrans, D., Bergbäck, B., Häggerud, A., 2006. New metal emission patterns in road traffic environments. *Environmental Monitoring and Assessment* 117, 85-98.
- Hjortenkrans, D.S.T., Bergbäck, B.G., Häggerud, A.V., 2007. Metal emissions from brake linings and tires: Case studies of Stockholm, Sweden 1995/1998 and 2005. *Environmental Science & Technology* 41, 5224-5230.
- Hjortenkrans, D.S.T., Bergbäck, B.G., Häggerud, A.V., 2008. Transversal immission patterns and leachability of heavy metals in road side soils. *Journal of Environmental Monitoring* 10, 739-746.
- Hollis, G.E., Ovenden, J.C., 1988. The quantity of stormwater runoff from 10 stretches of road, a car park and 8 roofs in Hertfordshire, England during 1983. *Hydrological Processes* 2, 227-243.
- Horn, R., Brümmer, G. W., Kandeler, E., Kögel-Knabner, I., Kretschmar, R., Stahr, K., & Wilke, B. M., 2010. Scheffer/Schachtschabel: Lehrbuch der bodenkunde. Springer-Verlag.

- Ingvertsen, S.T., Cederkvist, K., Jensen, M.B., Magid, J., 2012a. Assessment of existing roadside swales with engineered filter soil: II. Treatment efficiency and in situ mobilization in soil columns. *Journal of Environmental Quality* 41, 1970-1981.
- Ingvertsen, S.T., Cederkvist, K., Regent, Y., Sommer, H., Magid, J., Jensen, M.B., 2012b. Assessment of existing roadside swales with engineered filter soil: I. Characterization and lifetime expectancy. *Journal of Environmental Quality* 41, 1960-1969.
- Jankaitė, A., Pranas Baltrėnas, Kazlauskienė, A., 2008. Heavy metal concentrations in roadside soils of Lithuania's highways. *Geologija* 50 (4), 237-245.
- Jensen, M.B., 2004. Hydrological conditions for contaminant leaching through highway swales. *Water Air and Soil Pollution* 158, 169-180.
- Jensen, M.B., Holm, P.E., Laursen, J., Hansen, H.C.B., 2006. Contaminant aspects of blackish surface deposits on highway roadsides. *Water Air and Soil Pollution* 175, 305-321.
- Kayhanian, M., Fruchtman, B.D., Gulliver, J.S., Montanaro, C., Ranieri, E., Wuertz, S., 2012. Review of highway runoff characteristics: Comparative analysis and universal implications. *Water Research* 46, 6609-6624.
- Kluge, B., Werkenthin, M., Wessolek, G., 2014. Metal leaching in a highway embankment on field and laboratory scale. *Science of the Total Environment* 493, 495-504.
- Kluge, B., Wessolek, G., 2012. Heavy metal pattern and solute concentration in soils along the oldest highway of the world - the AVUS Autobahn. *Environmental Monitoring and Assessment* 184, 6469-6481.
- Koukoulidou, A., Heyer, D., Birle, E., 2014. Materials for stable embankment construction. Final Report FE 05.177/2012/MRB. Federal Ministry of Traffic, Germany, p. 69 (in German).
- Kocher, B., Brose, S., Siebertz, I., 2008. Pollutant Content in Roadside Soil Material. Report No. V 167. Federal Highway Research Institute (BAST), Germany, p. 56 (in German).
- Kocher, B., Wessolek, G., 2002. Transport of Traffic-related Contaminants with Percolation Water. Final Report FE 05.118/1997/GRB. Federal Ministry of Traffic, Germany, p. 99 (in German).
- Kocher, B., Wessolek, G., Stoffregen, H., 2005. Water and heavy metal transport in roadside soils. *Pedosphere* 15, 746-753.
- Kummer, U., Pacyna, I., Pacyna, E., Friedrich, R., 2009. Assessment of heavy metal releases from the use phase of road transport in Europe. *Atmospheric Environment* 43, 640-647.
- Lamble, K.J., Hill, S.J., 1998. Microwave digestion procedures for environmental matrices. *Analyst* 123, 103R-133R.
- LABO, 2003. Background values for inorganic and organic substances in soils. Landesarbeitsgemeinschaft Boden (LABO), edition, 2003 (in German).
- LAGA M20, 2004. Requirements on the material recycling of mineral residues/wastes – technical guidelines. Länderarbeitsgemeinschaft Abfall (LAGA), edition, 2004 (in German).
- Laxen, D., Harrison, R., 1977. The highway as a source of water pollution: An appraisal with the heavy metal lead. *Water Research* 11, 1 - 11.

- Lee, J.Y., Kim, H., Kim, Y., Han, M.Y., 2011. Characteristics of the event mean concentration (EMC) from rainfall runoff on an urban highway. *Environmental Pollution* 159, 884-888.
- LeFevre, G.H., Paus, K.H., Natarajan, P., Gulliver, J.S., Novak, P.J., Hozalski, R.M., 2015. Review of dissolved pollutants in urban storm water and their removal and fate in bioretention cells. *Journal of Environmental Engineering* 141, 04014050.
- Legret, M., Colandini, V., LeMarc, C., 1996. Effects of a porous pavement with reservoir structure on the quality of runoff water and soil. *Science of the Total Environment* 189, 335-340.
- Legret, M., Pagotto, C., 1999. Evaluation of pollutant loadings in the runoff waters from a major rural highway. *Science of the Total Environment* 235, 143-150.
- Legret, M., Pagotto, C., 2006. Heavy metal deposition and soil pollution along two major rural highways. *Environmental Technology* 27, 247-254.
- Li, L.Y., 2006. Retention capacity and environmental mobility of Pb in soils along highway corridor. *Water Air and Soil Pollution* 170, 211-227.
- Liang, B., Lehmann, J., Solomon, D., Kinyangi, J., Grossman, J., O'Neill, B., Skjemstad, J.O., Thies, J., Luizao, F.J., Petersen, J., Neves, E.G., 2006. Black Carbon increases cation exchange capacity in soils. *Soil Science Society of America Journal* 70, 1719-1730.
- Lindgren, A., 1996. Asphalt wear and pollution transport. *Science of the Total Environment* 189, 281-286.
- Makepeace, D.K., Smith, D.W., Stanley, S.J., 1995. Urban stormwater quality - summary of contaminant data. *Critical Reviews in Environmental Science and Technology* 25, 93-139.
- Makino, T., Hasegawa, S., Sakurai, Y., Ohno, S., Utagawa, H., Maejima, Y., Momohara, K., 2000. Influence of soil-drying under field conditions on exchangeable manganese, cobalt, and copper contents. *Soil Science and Plant Nutrition* 46, 581-590.
- Mangani, G., Berloni, A., Bellucci, F., Tatano, F., Maione, M., 2005. Evaluation of the pollutant content in road runoff first flush waters. *Water Air and Soil Pollution* 160, 213-228.
- Mansell, M., Rollet, F., 2006. Water balance and the behaviour of different paving surfaces. *Water and Environment Journal* 20, 7-10.
- McBride, M. B., 1994. *Environmental chemistry of soils*. Oxford university press; 1994.
- McKenzie, E.R., Money, J.E., Green, P.G., Young, T.M., 2009. Metals associated with stormwater-relevant brake and tire samples. *Science of the Total Environment* 407, 5855-5860.
- Merdy, P., Gharbi, L.T., Lucas, Y., 2009. Pb, Cu and Cr interactions with soil: Sorption experiments and modelling. *Colloids and Surfaces A: Physicochemical and Engineering Aspects* 347, 192-199.
- Mikkelsen, P.S., Hafliker, M., Ochs, M., Jacobsen, P., Tjell, J.C., Boller, M., 1997. Pollution of soil and groundwater from infiltration of highly contaminated stormwater - A case study. *Water Science and Technology* 36, 325-330.
- Modlingerova, V., Szakova, J., Sysalova, J., Tlustos, P., 2012. The effect of intensive traffic on soil and vegetation risk element contents as affected by the distance from a highway. *Plant Soil and Environment* 58, 379-384.

- Modrzewska, B., Wyszowski, M., 2014. Trace metals content in soils along the state road 51 (northeastern Poland). *Environmental monitoring and assessment* 186, 2589–2597.
- Monks, P.S., Granier, C., Fuzzi, S., Stohl, A., Williams, M.L., Akimoto, H., et al., 2009. Atmospheric composition change - global and regional air quality. *Atmospheric Environment* 43, 5268-5350.
- Motto, H.L., Daines, R.H., Chilko, D.M., Motto, C.K., 1970. Lead in soils and plants - its relationship to traffic volume and proximity to highways. *Environmental Science & Technology* 4, 231-237.
- Motuzas, A.J., Trimirka, V., Vaisvalavičius, R., Butkus, V., Prosyčevs, I., Zakarauskaitė, D., Vaišvila, Z., 2008. Methodological aspects of the assessment of roadside Luvisol contamination with heavy metals. *Žemės ūkio mokslai* 15 (3), 1-7.
- Münch, D., 1993. Concentration profiles of arsenic, cadmium, chromium, copper, lead, mercury, nickel, zinc, vanadium and polynuclear aromatic hydrocarbons (PAH) in forest soil beside an urban road. *Science of the Total Environment* 138, 47 - 55.
- Muschack, W., 1990. Pollution of street run-off by traffic and local conditions. *Science of the Total Environment* 93, 419-431.
- Nehls, T., Jozefaciuk, G., Sokolowska, Z., Hajnos, M., Wessolek, G., 2008. Filter properties of seam material from paved urban soils. *Hydrology and Earth System Sciences* 12, 691-702.
- Norrström, A.C., Jacks, G., 1998. Concentration and fractionation of heavy metals in roadside soils receiving de-icing salts. *Science of the Total Environment* 218, 161-174.
- Othman, I., AlOudat, M., AlMasri, M.S., 1997. Lead levels in roadside soils and vegetation of Damascus city. *Science of the Total Environment* 207, 43-48.
- Pagotto, C., Remy, N., Legret, M., Le Cloirec, P., 2001. Heavy metal pollution of road dust and roadside soil near a major rural highway. *Environmental Technology* 22, 307-319.
- Pal, S.K., Wallis, S.G., Arthur, S., 2011. Assessment of heavy metals emission from traffic on road surfaces. *Central European Journal of Chemistry* 9, 314-319.
- Perez, G., Lopez-Mesas, M., Valiente, M., 2008. Assessment of heavy metals remobilization by fractionation: Comparison of leaching tests applied to roadside sediments. *Environmental Science & Technology* 42, 2309-2315.
- Piguet, P., Parriaux, A., Bensimon, M., 2008. The diffuse infiltration of road runoff: an environmental improvement. *Science of the Total Environment* 397, 13-23.
- Pitt, R., Clark, S., Field, R., 1999. Groundwater contamination potential from stormwater infiltration practices. *Urban water* 1, 217-236.
- Pleniscar, A., Zupancic, N., 2005. Heavy metal contamination of roadside soil along Ljubljana-Obrezhe highway. *RMZ-Materials and Geoenvironment* 52, 403-418.
- Pouyat, R.V., Yesilonis, I.D., Russell-Anelli, J., Neerchal, N.K., 2007. Soil chemical and physical properties that differentiate urban land-use and cover types. *Soil Science Society of America Journal* 71, 1010-1019.
- Preciado, H.F., Li, L.Y., 2006. Evaluation of metal loadings and bioavailability in air, water and soil along two highways of British Columbia, Canada. *Water Air and Soil Pollution* 172, 81-108.



- Pribyl, D.W., 2010. A critical review of the conventional SOC to SOM conversion factor. *Geoderma* 156, 75-83.
- Radenberg, M., Kollar, J., 2012. Laboratory process for determination of the water permeability of unbound building materials. Final Report FE 06.084/2006/FGB. Federal Ministry of Traffic, Germany, p. 44 (in German).
- Ragab, R., Rosier, P., Dixon, A., Bromley, J., Cooper, J.D., 2003. Experimental study of water fluxes in a residential area: 2. Road infiltration, runoff and evaporation. *Hydrological Processes* 17, 2423-2437.
- Radenberg, M., Kollar, J., 2012. Laboratory process for determination of the water permeability of unbound building materials. Final Report FE 06.084/2006/FGB. Federal Ministry of Traffic, Germany, p. 44 (in German).
- Ramakrishna, D.M., Viraraghavan, T., 2005. Environmental impact of chemical deicers - A review. *Water Air and Soil Pollution* 166, 49-63.
- RAS-Ew 2005. Directive for road construction, part dewatering (RAS-Ew). Road and Transportation Research Association (FGSV), edition, 2005 (in German).
- Reinirkens, P., 1996. Analysis of emissions through traffic volume in roadside soils and their effects on seepage water. *Science of the Total Environment* 189, 361-369.
- Rennert, T., Rinklebe, J., 2010. Release of Ni and Zn from contaminated floodplain soils under saturated flow conditions. *Water Air and Soil Pollution* 205, 93-105.
- Revitt, D.M., Hamilton, R.S., Warren, R.S., 1990. The transport of heavy-metals within a small urban catchment. *Science of the Total Environment* 93, 359-373.
- Rijkenberg, M.J.A., Depree, C.V., 2010. Heavy metal stabilization in contaminated road-derived sediments. *Science of the Total Environment* 408, 1212-1220.
- RiStWag 2002. Guidelines for structural measures on roads in water protection areas. Road and Transportation Research Association (FGSV), edition, 2002 (in German)
- Rodriguez-Flores, M., Rodriguez-Castellon, E., 1982. Lead and cadmium levels in soil and plants near highways and their correlation with traffic density. *Environmental Pollution Series B-Chemical and Physical* 4, 281-290.
- Roulier, S., Robinson, B., Kuster, E., Schulin, R., 2008. Analysing the preferential transport of lead in a vegetated roadside soil using lysimeter experiments and a dual-porosity model. *European Journal of Soil Science* 59, 61-70.
- Saeedi, M., Hosseinzadeh, M., Jamshidi, A., Pajooheshfar, S.P., 2009. Assessment of heavy metals contamination and leaching characteristics in highway side soils, Iran. *Environmental Monitoring and Assessment* 151, 231-241.
- Sansalone, J.J., Buchberger, S.G., 1997a. Characterization of solid and metal element distributions in urban highway stormwater. *Water Science and Technology* 36, 155-160.
- Sansalone, J.J., Buchberger, S.G., 1997b. Partitioning and first flush of metals in urban roadway storm water. *Journal of Environmental Engineering-ASCE* 123, 134-143.

- Schuwirth, N., Hofmann, T., 2006. Comparability of and alternatives to leaching tests for the assessment of the emission of inorganic soil contamination. *Journal of Soils and Sediments* 6, 102-112.
- Simon, E., Vidic, A., Braun, M., Fabian, I., Tothmeresz, B., 2013. Trace element concentrations in soils along urbanization gradients in the city of Wien, Austria. *Environmental Science and Pollution Research* 20, 917-924.
- Steiner, M., Boller, M., Schulz, T., Pronk, W., 2007. Modelling heavy metal fluxes from traffic into the environment. *Journal of Environmental Monitoring* 9, 847-854.
- Sternbeck, J., Sjodin, A., Andreasson, K., 2002. Metal emissions from road traffic and the influence of resuspension - results from two tunnel studies. *Atmospheric Environment* 36, 4735-4744.
- Stevovic, S., Mikovilovic, V.S., Calic-Dragosavac, D., 2010. Environmental study of heavy metals influence on soil and Tansy (*Tanacetum vulgare* L.). *African Journal of Biotechnology* 9, 2392-2400.
- Stumm, W., Morgan, J. J., 2012. *Aquatic chemistry: chemical equilibria and rates in natural waters* (Vol. 126). John Wiley & Sons.
- Thorpe, A., Harrison, R.M., 2008. Sources and properties of non-exhaust particulate matter from road traffic: A review. *Science of the Total Environment* 400, 270-282.
- Trombulak, S.C., Frissell, C.A., 2000. Review of ecological effects of roads on terrestrial and aquatic communities. *Conservation Biology* 14, 18-30.
- Turer, D., Maynard, B., 2003. Heavy metal contamination in highway soils. Comparison of Corpus Christi, Texas and Cincinnati, Ohio shows organic matter is key to mobility. *Clean Technologies and Environmental Policy* 4, 235-245.
- Turer, D., Maynard, J.B., Sansalone, J.J., 2001. Heavy metal contamination in soils of urban highways: Comparison between runoff and soil concentrations at Cincinnati, Ohio. *Water Air and Soil Pollution* 132, 293-314.
- Van Bohemen, H.D., Van de Laak, W.H.J., 2003. The influence of road infrastructure and traffic on soil, water, and air quality. *Environmental Management* 31, 50-68.
- Walraven, N., van Os, B.J.H., Klaver, G.T., Middelburg, J.J., Davies, G.R., 2014. The lead (Pb) isotope signature, behaviour and fate of traffic-related lead pollution in roadside soils in The Netherlands. *Science of the Total Environment* 472, 888-900.
- Ward, N.I., 1990. Multielement contamination of british motorway environments. *Science of the Total Environment* 93, 393-401.
- Warren, R., Birch, P., 1987. Heavy metal levels in atmospheric particulates, roadside dust and soil along a major urban highway. *Science of the Total Environment* 59, 253 - 256.
- Weiss, P., LeFevre, G., Gulliver, J., 2008. Contamination of Soil and Groundwater Due to Stormwater Infiltration Practices: a Literature Review. University of Minnesota; St. Anthony Falls Laboratory Project Report No.515. Prepared for Minnesota Pollution Control Agency. Available June 23, 2008 [www.pca.state.mn.us/index.php/download-document.html?gid=7732](http://www.pca.state.mn.us/index.php/download-document.html?gid=7732)
- Weng, L.P., Temminghoff, E.J.M., Lofts, S., Tipping, E., Van Riemsdijk, W.H., 2002. Complexation with dissolved organic matter and solubility control of heavy metals in a sandy soil. *Environmental Science & Technology* 36, 4804-4810.

- Werkenthin, M., Kluge, B., Wessolek, G., 2014. Metals in European roadside soils and soil solution - A review. *Environmental Pollution* 189, 98-110.
- Wessolek, G., Duijnsveld, W.H.M., Trinks, S., 2008. Hydro-pedotransfer functions (HPTFs) for predicting annual percolation rate on a regional scale. *Journal of Hydrology* 356, 17-27.
- Wessolek, G., Kluge, B., Toland, A., Nehls, T., Klingelmann, E., Rim, Y.N., Mekiffer, B., Trinks, S., 2011. Urban soils in the vadose zone. In: Endlicher, W. (Ed.), *Perspectives in Urban Ecology*, Springer Berlin Heidelberg.
- Westerholm, R., Egeback, K.E., 1994. Exhaust emissions from light-duty and heavy-duty vehicles - chemical-composition, impact of exhaust after treatment, and fuel parameters. *Environmental Health Perspectives* 102, 13-23.
- Westerlund, C., Viklander, M., 2006. Particles and associated metals in road runoff during snowmelt and rainfall. *Science of the Total Environment* 362, 143-156.
- WHG – Gesetz zur Ordnung des Wasserhaushaltes (Wasserhaushaltsgesetz vom 19. August 2002 (BGBl. I S. 3245): in German; 2002.
- Wigington, P.J., Randall, C.W., Grizzard, T.J., 1986. Accumulation of Selected Trace-metals In Soils of Urban Runoff Swale Drains. *Water Resources Bulletin* 22, 73-79.
- Zanders, J.M., 2005. Road sediment: characterization and implications for the performance of vegetated strips for treating road run-off. *Science of the Total Environment* 339, 41-47.
- Zechmeister, H.G., Hohenwallner, D., Riss, A., Hanus-Illar, A., 2005. Estimation of element deposition derived from road traffic sources by using mosses. *Environmental Pollution* 138, 238-249.
- Zehetner, F., Rosenfellner, U., Mentler, A., Gerzabek, M.H., 2009. Distribution of road salt residues, heavy metals and polycyclic aromatic hydrocarbons across a highway-forest interface. *Water Air and Soil Pollution* 198, 125-132.
- Zhang, W., Brown, G.O., Storm, D.E., 2008. Enhancement of heavy metal retention in sandy soil by amendment with fly ash. *Transactions of the ASABE* 51, 1247-1254.
- Zinkutė, R., Evelina Brannvall, Taraškevičius, R., 2007. Variation of trace element accumulation in top-soil near the Vilnius–Kaunas highway. *Geologija* 2 (2007). 58, 1-9.
- ZTVE-StB 2009. Additional technical conditions of contract and guidelines for earthworks in road construction. Road and Transportation Research Association (FGSV) No. 599, 2009 (in German).
- Zuo, X., Fu, D., Li, H., 2012. Speciation distribution and mass balance of copper and zinc in urban rain, sediments, and road runoff. *Environmental Science and Pollution Research* 19, 4042-4048.

## List of figures

Fig. 1.1:	Sources of contaminants in the roadside environment, derived from Folkeson et al. (2009).....	3
Fig. 1.2:	Fractions of metals, Na and Ca of total depositions at a German highway site in 0-1 m distance from the road, adapted from Kocher and Wessolek (2002).....	4
Fig. 1.3:	Lateral pattern Cd and Pb distribution in the top 10 cm along the A115 highway near Berlin, adapted from Kluge and Wessolek (2012). ....	6
Fig. 1.4:	Dye distribution in a roadside soil profile illustrating the preferential flow paths, adapted from Garrido and Helmhart (2011).....	7
Fig. 1.5:	Metal concentrations in groundwater measured upgradient and downgradient from a highway in Massachusetts, USA, adapted from Granato et al. (1995). ....	8
Fig. 1.6:	Flowchart for the choice of the proper dewatering procedure (adapted from RAS-Ew, 2005). ....	10
Fig 1.7:	Top: Schematic sketch/ profile of a road construction suitable for dewatering across the embankment and slope derived from the RAS-Ew (2005). Bottom: Pictures of an embankment during compaction (left), an embankment right after construction (second from the right) with a channelled runoff collection system, an installed and compacted stable embankment soil (second from the right) and an existing greened embankment and slope suitable for diffuse infiltration (right). ....	11
Fig. 1.8:	Visualisation of the approach of the data synthesis conducted in the review study. ....	14
Fig. 1.9:	Pictures of a rainfall event, sampling chamber and installed wick (from left to right).....	15
Fig. 1.10:	Pictures of soil saturation extract (left) and column experiments (right).....	16
Fig. 1.11:	Sketch of the lysimeter site setup (top) with sampling vessels for road runoff (RR), surface runoff (SR) and seepage water (SW). Pictures of a greened lysimeter, empty lysimeter tubes, lysimeter site right after installation and tipping buckets with sampling vessels (bottom left to right).....	17
Fig. 2.1:	Schematic sketch of a roadside environment and pathways for pollutant dispersion. ....	22
Fig. 2.2:	Schematic map of study site locations in Europe.....	24
Fig. 2.3:	Metal concentrations in roadside soils at 0 – 5 cm soil depth as a function of distance to the road edge (median: bold line, upper & lower quartile: grey box and upper & lower interquartile dashed lines, outliers are not displayed). Dotted horizontal line: composed European median background concentrations. The data are taken from the studies listed in Tab. 2.1.....	32
Fig. 2.4:	Median soil pH and metal concentrations at 5–<10 m and at 10–25 m distance to the road edge relative to concentrations at 0–<5 m.....	33
Fig. 2.5:	Metal concentrations of roadside soils at 0 – 5 m distance as a function of soil depths (median: bold line, upper & lower quartile: grey box and upper & lower interquartile dashed lines; outliers are not displayed). The data are taken from the studies listed in Tab. 2.1.....	35

Fig. 2.6:	Median soil pH and metal concentrations at >5–15 cm and >15–70 cm soil depth relative to the concentrations at 0–5 cm.....	37
Fig. 2.7:	Median pH, EC and metal concentration of soil solution at 50-cm depth at highway sites (AADT 50,000–120,000) as a function of distance from the road edge. Bars indicate minimum and maximum concentrations. ....	42
Fig. 2.8:	Median pH, EC and metal concentration of soil solution at 50-cm depth at major road sites (AADT 7000–20,000) as a function of distance from the road edge. Bars indicate minimum and maximum concentrations. ....	43
Fig. 2.9:	Schematic illustration of the mean annual percolation rate (top), mean cadmium and Ni concentration in soil solution at 0.5 m depth (middle) and annual leaching rates (bottom) on a highway roadside as a function of distance based on data of Kocher et al. (2005) and Kluge and Wessolek (2012).....	46
Fig. 3.1:	Location of the study site-AVUS A115, Berlin, Germany .....	51
Fig. 3.2:	Schematic sketch of a wick lysimeter setup (left side) and pictures of the monitoring site (top) and a wick lysimeter (bottom).....	53
Fig. 3.3:	Mean road runoff concentrations of dissolved and particle-bound metals at the AVUS highway. Dashed line separates the two different y-scales. ....	58
Fig. 3.4:	Mean total metal concentrations of AVUS runoff compared with mean runoff concentrations from other authors (*Krauth and Klein 1990 in Muschak 1990; **this study; ***Dierkes and Geiger 1999; ****Diehl 2002 in Kluge. 2010; *****Göbel et al. 2007).Dashed line separates the two different y-scales.....	58
Fig. 3.5:	Median concentrations in mg kg <sup>-1</sup> of metals in the embankment soils (T) at different depths and distances and at the reference site (n=90). The background levels of Ni and Cr are for the region Berlin/Brandenburg. The radius of the circles is proportional to the median concentration of a specific element.....	60
Fig. 3.6:	Mean dissolved and particle-bound metal concentrations in soil solution at 2.5m distance from the AVUS roadside-50 cm soil depth. Dashed line separates the two different y-scales.....	62
Fig. 3.7:	Adsorption isotherms of Pb, Cd, Cu and Zn from the AVUS embankment soil (B) and the reference soil (R) at 800 m distance from the roadside. ....	64
Fig. 3.8:	Comparison of the Cd, Cu, Pb and Zn concentrations in soil solution determined in field studies (suction cups), laboratory experiments (column, batch SSE and batch S4) and calculated values using the adsorption isotherms (AI).....	66
Fig. 4.1:	Schematic sketch of an embankment lysimeter with tipping buckets and sampling vessels (left). Pictures of the six lysimeters (middle), tipping buckets and sampling vessels (right). The runoff lysimeters are marked with 1, 3 and 5, the embankment lysimeters with 2, 4 and 6. ....	71
Fig. 4.2:	Annual water volume (mm) of the runoff (RR1-3) and embankment lysimeters (TSM, MTB, BCM). ....	74
Fig. 4.3:	Dissolved (top) and particle-bound (bottom) metal concentrations in road runoff of the A115 (median, min., max., upper and lower quartile; outliers are not displayed). Note: the bold dashed line separates the plot into two different y-scales.	
	76	
Fig. 4.4:	Median dissolved (n=12), particle-bound (n=12) and sediment (n=1) metal concentrations in soil solution of different embankments (TSM, MTB, BCM) and	

	in the infiltrating road runoff (RR). The dashed line marks the trigger values of the BBodSchV (1999). .....	78
Fig. 4.5:	Total Cu and Pb concentrations in soil solution of the embankment lysimeter (MTB, TSM, BCM) and road runoff (RR) as well as precipitation and mean soil temperature.....	80
Fig. 4.6:	Annual metal output loads exported via soil solution from the embankment lysimeters ( $\text{mg m}^{-2} \text{ a}^{-1}$ ) and annual metal loads introduced via road runoff (input). The radius of the circles is proportional to the load of a specific metal. For the road runoff the variability due to different runoff volumes was also calculated ( $\pm$ ). 81	
Fig. S1:	Cumulative monthly road runoff volumes (mm) determined with the three runoff lysimeters (RR1-RR3). .....	XXI
Fig. S2:	Dissolved (top) and particle-bound (bottom) metal concentrations in road runoff of the A115 (median, min., max., upper and lower quartile and outliers). Note: the bold dashed line separates the plot into two different y-scales. ....	XXI

## List of tables

Tab. 1.1:	Median metal concentrations in road runoff obtained from different investigations. .....	5
Tab. 2.1:	Register of referenced studies. ....	28
Tab. 2.2:	Pearson correlation coefficients between a) trace element concentrations (mg kg <sup>-1</sup> ) at soil depth ≤ 5 cm, pH (-), LOI (%) and distance (m) and b) trace element concentrations (mg kg <sup>-1</sup> ) at road distance < 5 m, pH (-), LOI (%) and depth (cm). Bold type indicates a statistical significant correlation.....	38
Tab. 2.3:	Pearson correlation coefficients and the corresponding scatter plots for soil trace element concentrations (mg kg <sup>-1</sup> ) at soil depth ≤5 cm and road distance <5 m, pH (-), LOI (%) and AADT (vehicles day <sup>-1</sup> ). Bold type indicates a statistical significant correlation. ....	39
Tab. 2.4:	Pearson correlation coefficients between trace element concentrations in soil solution (depth 50 cm, road distance <5 m), pH, EC and AADT. Bold type indicates a statistical significant correlation. ....	44
Tab. 3.1:	Metal additions (mg L <sup>-1</sup> ) for the batch adsorption experiments. ....	55
Tab. 3.2:	Soil properties of the different soil samples used for the batch leaching experiments. 57	
Tab. 3.3:	Precautionary values for sandy soils and trigger values for the transfer of soil solution to the groundwater of the German Federal Soil Protection and Contamination Ordinance (BBodSchV, 1999) Germany. ....	61
Tab. 3.4:	Retardation factors of the AVUS embankment soil (B) and the reference soil (R) at 800 m distance from the road.....	64
Tab. 4.1:	Heavy metal concentrations, soil properties (fraction <2 mm) and texture of the embankment soils. ....	73
Tab. 4.2:	Mean dissolved and total metal concentrations in road runoff determined in comparison with other studies.....	77
Tab. 4.3:	Metal reduction of the different embankment lysimeters. Negative reduction indicates a metal release of the embankment materials. ....	79
Tab. S1:	Loss of ignition (LOI), pH and metal concentrations in road side soils at at different depth and distance from road determined by different authors. XIII-XVIII	
Tab. S2:	Electrical conductivity (EC), pH and metal concentrations of soil solution in road side soils at different distances from road at 50 cm soil depth determined by different authors. ....	XIX
Tab S3:	Metal concentrations and pH values of the transect at the AVUS embankment (T) at different depth and distance from road. ....	XX

## Appendix - supplementary material

Tab. S1: Loss of ignition (LOI), pH and metal concentrations in road side soils at different depth and distance from road determined by different authors.

Reference	Location	AADT	Distance	Depth	pH	LOI	Cd	Cr	Cu	Ni	Pb	Zn
			m	cm	(CaCl)	%	mg kg <sup>-1</sup>					
Kluge and Wessolek (2012)	Berlin (D)	100000	2.5	5	6	3	0.7	-	30.8	-	147	123
			2.5	15	-	-	0.3	-	13.6	-	28.2	65.7
			5	5	-	-	1.1	-	39	-	60.2	183
			10	5	-	-	0.5	-	28.7	-	98.8	62.4
			Background	-	-	-	0.1	-	2.5	-	24	17.5
Kocher and Wessolek (2002)	Hannover (D)	70000	1	5	6.54	3.07	10.5	0.42	35	11.6	76.5	158
			1	17	6.54	3.07	10.5	0.42	35	11.6	76.5	158
			1	44	6.19	0.21	0.02	1.6	2.07	2.54	1.99	7
			5	5	4.79	3.03	0.17	3.08	6.45	1.41	25.7	64
			10	5	3.53	3.66	0.1	2.71	2.64	1.83	20.5	11
			Background	-	-	-	-	-	-	-	-	-
Kocher and Wessolek (2002)	Hannover (D)	70000	1	5	6.62	4.96	0.56	11.4	55.8	17.9	106	732
			1	15	6.12	0.96	0.12	4.01	6.82	3.72	12.9	107
			1	50	5.88	0.07	0.01	2.61	1.64	2.94	1.89	35
			5	5	5.07	2.78	0.19	5.65	6.77	3.07	25.3	84
			10	5	5.2	2.58	0.14	11.9	5.95	3.05	20	78
			Background	-	-	-	-	-	-	-	-	-
Kocher and Wessolek (2002)	Hannover (D)	50000	1	5	6.09	4.95	0.74	22.7	47.9	21	168	205
			1	15	6.01	0.19	0.05	11.3	4.28	14.7	6.51	17
			1	59	5.87	0.1	0.02	6.94	0.84	3.52	1.94	8
			5	5	4.43	3.77	0.29	9.56	13.8	3.35	92.3	73
			10	5	4.33	1.25	0.16	12.2	4.78	6.93	30.5	30
			Background	-	-	-	-	-	-	-	-	-
Kocher and Wessolek (2002)	Berlin (D)	90000	1	5	6.78	2.25	1.18	18	107	22	207	380
			1	29	7.27	0.35	0.39	4.74	14.1	8.01	38.7	119
			1	60	7.34	0.12	0.28	3.62	6.63	3.44	16.5	66
			5	13	5.78	1.38	1.38	6.58	25.2	8.4	50.9	120
			10	5	3.87	6.45	0.43	5.44	22.7	9.02	122	91
			Background	-	-	-	-	-	-	-	-	-
Kocher and Wessolek (2002)	Celle (D)	20000	1	5	6.49	3.29	1	15	35	25	90	120
			1	25	7.28	1.39	0.31	12	14.2	21	82	107
			1	50	6.74	0.1	0.03	3.42	1.07	9.88	1.47	13
			6	5	4.91	2.02	0.22	4.8	11	9	25	70
			10	5	4.74	2.21	0.14	4.57	4.38	2.21	22.9	68
			Background	-	-	-	-	-	-	-	-	-



Tab. S1: (continued) Loss of ignition (LOI), pH and metal concentrations in road side soils at different depth and distance from road determined by different authors.

Reference	Location	AADT	Distance	Depth	pH	LOI	Cd	Cr	Cu	Ni	Pb	Zn
			m	cm	(CaCl)	%	mg kg <sup>-1</sup>					
Kocher and Wessolek (2002)	Celle (D)	20000	1.5	5	6.8	2.97	1.13	23.5	52.3	36.3	128	193
			1	25	6.73	1.61	0.27	6.86	15.9	13.3	53.5	61
			1	61	6.63	0.79	0.02	2.97	2.54	1.88	2.53	11
			4	23	6.77	2.93	0.34	8.66	14.7	18.3	39.1	130
			10	10	3.14	5.68	0.14	1.03	2.54	1.52	14.5	17
			Background	-	-	-	-	-	-	-	-	-
Kocher and Wessolek (2002)	Braunschweig (D)	20000	1	5	7.01	2.08	0.22	6.84	12.5	13.7	20.8	80
			1	19	6.96	2.08	0.18	5.35	6.8	14.3	20.2	68
			1	50	6.24	2.93	0.02	2.96	3.34	1.07	1.95	4
			5	15	5.2	2.98	0.21	3.5	5.21	2.6	21.9	48
			10	5	4.02	3.13	0.13	3.34	3.24	1.05	17.5	12
			Background	-	-	-	-	-	-	-	-	-
Kocher and Wessolek (2002)	Celle (D)	20000	1	5	6.53	2.05	0.21	8.32	7	4.37	31.2	109
			1	28	6.68	0.95	0.13	14.7	4.43	16.8	6.04	89
			1	78	6.47	0.64	0.02	9.47	2.6	3.7	3.79	82
			5	5	5.65	3.52	0.19	7.14	7.88	4.41	4.44	85
			10	5	5.22	4.25	0.19	13.8	9.31	3.38	5.59	36
			Background	-	-	-	-	-	-	-	-	-
Dierkes and Geiger (1999)	Gelsenkirchen (D)	107600	0.5	2.5	7.4	8.7	3.9	-	413	-	239	527
			1	7.5	7.4	8.7	3.5	-	78	-	202	361
			1	20	7.6	2.4	2.7	-	31	-	34	99
			5	2.5	7.4	8.7	2	-	42	-	141	231
			10	2.5	7.4	8.7	1.8	-	27	-	65	155
			Background	-	-	-	-	-	-	-	-	-
Dierkes and Geiger (1999)	Mülheim (D)	93700	2	2.5	7.4	8.7	2	-	25	-	81	174
			2	7.5	7.4	8.7	1.9	-	20	-	69	141
			2	20	7.6	2.4	1.1	-	11	-	67	115
			Background	-	-	-	-	-	-	-	-	-
Dierkes and Geiger (1999)	Gladbeck (D)	78000	0.75	2.5	7.4	8.7	4.3	-	268	-	276	759
			0.75	7.5	7.4	8.7	2.6	-	155	-	130	303
			0.75	20	7.6	2.4	2.5	-	23	-	54	112
			Background	-	-	-	-	-	-	-	-	-
Dierkes and Geiger (1999)	Oberhausen (D)	79900	2	2.5	7.4	8.7	5.6	-	167	-	290	1580
			2	7.5	7.4	8.7	8.5	-	155	-	348	1630
			2	20	7.6	2.4	3.1	-	23	-	27	138
			Background	-	-	-	-	-	-	-	-	-
Dierkes and Geiger (1999)	Bottrop (D)	52000	0.75	2.5	7.4	8.7	2.2	-	40	-	71	187
			0.75	7.5	7.4	8.7	2.5	-	42	-	53	120
			0.75	20	7.6	2.4	-	-	24	-	18	69
			Background	-	-	-	-	-	-	-	-	-
Reimerkes (1996)	North-Rhine-Westphalia (D)	-	5	2.5	5.3	-	0.8	-	69	-	37.5	68
			25	2.5	5.1	-	0.3	-	5.8	-	20.2	41.4
			Background	2.5	4	-	0.2	-	7.3	-	24.3	37.8

## Appendix - supplementary material

Tab. S1: (continued) Loss of ignition (LOI), pH and metal concentrations in road side soils at different depth and distance from road determined by different authors.

Reference	Location	AADT	Distance	Depth	pH	LOI	Cd	Cr	Cu	Ni	Pb	Zn
			m	cm	(CaCl)	%	mg kg <sup>-1</sup>					
Reinierkes (1996)	North-Rhine-Westphalia (D)	-	5	2.5	6.7	-	0.5	-	22.1	-	42	114
			25	2.5	6.2	-	0.5	-	12.7	-	49.5	74.5
			Background	2.5	6.7	-	0.4	-	13.7	-	30.2	73.1
Bäckstrom et al. (2004)	Svanenberg (S)	7400	3	2.5	6.69	2.83	-	-	-	-	-	-
			Background	-	-	-	-	-	-	-	-	-
Bäckstrom et al. (2004)	Norsholm (S)	15600	3	2.5	8.47	4.31	-	-	-	-	-	-
			Background	-	-	-	-	-	-	-	-	-
Christoforidis and Stamatis (2009)	Kavala rural (GR)	-	3	1	-	-	0.1	133	17.7	26	59.4	65.6
			Background	-	-	-	-	-	-	-	-	-
Christoforidis and Stamatis (2009)	Kavala urban (GR)	-	3	1	-	-	0,2	240	48,1	77,4	571	175
			Background	-	-	-	-	-	-	-	-	-
Hjortenkrans et al. (2008)	Kalmar (S)	22300	1,4	3	6,1	5,1	0,28	31	55	8,3	110	170
			1,4	6	6	2,3	0,12	16	16	7,7	110	79
			1,4	15	5,9	0,63	0,06	7,7	8,4	3,3	15	34
			5	3	5	2,9	0,1	12	15	5,6	53	89
			10	3	5	6,4	0,14	19	11	6,2	19	38
			Background	3	5,1	7,8	0,17	22	12	5,2	24	38
Hjortenkrans et al. (2008)	Varberg (S)	20700	1,4	3	4,7	8,3	0,72	6,7	19	2,7	12	45
			1,4	6	4,4	7,4	0,76	4	4,9	1	6	19
			1,4	15	4,2	5,7	0,06	12	6,6	3,7	4,2	28
			5	3	5,7	5,1	0,06	14	8,2	6,6	2,8	27
			10	3	5,8	7	0,05	15	8,7	6,4	2,3	31
			Background	-	-	-	-	-	-	-	-	-
Mangani et al. (2005)	Urbino (I)	13200	2,5	2,5	-	-	4,69	-	51	-	66,6	438
			Background	-	-	-	1,4	-	1,4	-	46,1	160
Mangani et al. (2005)	Urbino (I)	13200	2,5	-	-	-	4,43	-	9,86	-	102	87,9
			Background	2,5	-	-	1,4	-	1,4	-	46,1	160
Legret and Pagotto (2006)	Nantes (F)	24000	0,5	1	7,4	-	0,58	60	63	-	212	669
			0,5	6	7,4	-	0,09	74	16	-	31	102
			0,5	20	7,4	-	0,07	77	17	-	30	73
			5	6	7,4	-	0,04	70	27	-	35	100
			25	6	7,4	-	0,07	70	26	-	39	99
			Background	-	-	-	-	-	-	-	-	-
Legret and Pagotto (2006)	Paris (F)	21000	0,5	1	7,3	-	1,58	43	173	-	364	338
			0,5	6	7,3	-	1,85	39	99	-	683	338
			0,5	20	7,3	-	1,39	33	54	-	434	198
			5	6	7,3	-	0,21	54	11	-	54	48
			25	6	7,3	-	0,11	52	8	-	37	38
			Background	-	-	-	-	-	-	-	-	-

Tab. S1: (continued) Loss of ignition (LOI), pH and metal concentrations in road side soils at different depth and distance from road determined by different authors.

Reference	Location	AADT	Distance	Depth	pH	LOI	Cd	Cr	Cu	Ni	Pb	Zn
			m	cm	(CaCl)	%	mg kg <sup>-1</sup>					
Akbar et al. (2006)	North and west Yorkshire (GB)	21000	0,25	13	-	-	1,8	-	102	-	378	208
			2,5	13	-	-	1,4	-	90	-	201	169
			5,5	13	-	-	1,3	-	83	-	178	158
			Background	-	-	-	-	-	-	-	-	-
Grigalaviciene et al. (2005)	Kaunas-Vilnius (LT)	13800	5	5	7,4	2,36	0,93	7,5	-	-	44,3	-
			10	5	7,1	2,36	0,75	5,4	-	-	37,3	-
			25	5	6,5	2,36	0,51	4	-	-	20,5	-
			Background	5	4,7	2,36	0,22	2,3	-	-	10,6	-
Warren and Birch (1987)	London (GB)	70000	1	7.5	-	-	6	-	346	-	1769	972
			6	7.5	-	-	3	-	179	-	957	534
			10	7.5	-	-	1.4	-	117	-	443	490
			Background	7.5	-	-	0.2	-	31	-	124	93.9
Münch (1993)	Dortmund (D)	3200	1	2.5	-	12.5	1.96	64	34	32	245	241
			6	2.5	-	12.5	-	37	28	-	-	-
			10	2.5	-	12.5	0.35	17	23	8.2	52	81
			Background	-	-	-	-	-	-	-	-	-
Hjortenkrans et al. (2006)	South Sweden (S)	17000	0.25	2.5	6.5	6	0.26	24	64	11	44	180
			Background	-	-	-	0.16	10	8.3	4.4	13	48
Pleniscar and Zupancic (2005)	Ljubljana-Krakovski Gozd (SLO)	14000	1	2.5	-	40.7	0.73	-	58.1	21.1	481	250
			5	2.5	-	15.3	0.4	-	29	19.4	179	119
			10	2.5	-	17.5	0.25	-	16.7	21.2	92.4	77.5
			Background	-	-	-	-	-	-	-	-	-
Pleniscar and Zupancic (2005)	Ljubljana-Krakovski Gozd (SLO)	13000	1	2.5	-	14.7	0.7	-	16.2	27.8	30.3	51
			5	2.5	-	14.9	0.8	-	18.2	30.1	40.6	63
			10	2.5	-	24	0.7	-	16.2	17.8	5.2	66
			Background	-	-	-	-	-	-	-	-	-
Pleniscar and Zupancic (2005)	Ljubljana-Dob (SLO)	15400	1	2.5	-	12.8	1.2	-	23.7	22.8	34.4	76
			5	2.5	-	17.6	1.4	-	24.5	24.3	32.2	65
			10	2.5	-	17.8	1	-	23.9	23.4	30.2	71.3
			Background	-	-	-	-	-	-	-	-	-
Pleniscar and Zupancic (2005)	Ljubljana-Ivancna Gorica (SLO)	2500	1	2.5	-	13.6	1.2	-	23.3	22.8	37.7	92.5
			5	2.5	-	22.4	4.9	-	50.4	48.7	131	170
			10	2.5	-	23.6	1.2	-	37.7	31.2	105	130
			Background	-	-	-	-	-	-	-	-	-
Pleniscar and Zupancic (2005)	Ljubljana-Dedni Dol (SLO)	14000	1	2.5	-	37	0.7	-	54.7	21.2	227	873
			5	2.5	-	27.3	0.6	-	15.3	21.8	45.1	57
			10	2.5	-	33.9	0.4	-	11.4	18.2	24	44
			Background	-	-	-	-	-	-	-	-	-
Bakirdere and Yaman (2008)	Elazig (TR)	-	0	2.5	-	-	0.19	-	14.3	-	5.1	-
			25	2.5	-	-	0.17	-	13.9	-	5.3	-
			Background	2.5	-	-	0.09	-	15.2	-	3.7	-

Tab. S1: (continued) Loss of ignition (LOI), pH and metal concentrations in road side soils at different depth and distance from road determined by different authors.

Reference	Location	AADT	Distance	Depth	pH	LOI	Cd	Cr	Cu	Ni	Pb	Zn
			m	cm	(CaCl)	%	mg kg <sup>-1</sup>					
Bakirdere and Yaman (2008)	Elazig (TR)	-	0	2.5	-	-	0.35	-	22.5	-	26.2	-
			25	2.5	-	-	0.18	-	16.8	-	4.4	-
			Background	2.5	-	-	0.14	-	15.9	-	2.65	-
Bakirdere and Yaman (2008)	Elazig (TR)	-	0	2.5	-	-	0.13	-	18.3	-	14	-
			25	2.5	-	-	0.13	-	19	-	6.6	-
			Background	2.5	-	-	0.14	-	15.8	-	4.9	-
Bakirdere and Yaman (2008)	Elazig (TR)	-	0	2.5	-	-	0.21	-	17.5	-	16.7	-
			25	2.5	-	-	0.17	-	16.2	-	4.7	-
			Background	2.5	-	-	0.18	-	14.7	-	4.2	-
Boivin et al. (2008)	Riddes (CH)	19000	0.25	5	7.85	1.9	-	142	33	47	27	76
			0.25	55	7.85	1.9	-	150	33	51	23	72
			0.25	85	7.85	0.4	-	106	30	33	10	50
			1.25	5	7.85	1.9	-	146	29	46	22	65
			2.75	5	7.85	1.9	-	113	32	35	18	60
			Background	-	-	-	-	13	13.3	24	10	32
Boivin et al. (2008)	St Leonard (CH)	15750	0.25	5	7.85	1.9	-	148	36	48	32	159
			0.25	55	7.85	1.3	-	160	31	46	22	73
			0.25	85	7.85	0.4	-	123	25	43	15	93
			1.25	5	7.85	1.9	-	150	36	47	24	75
			2.75	5	7.85	1.9	-	149	33	46	24	75
			Background	-	-	-	-	13	13.3	24	10	32
Zehetner et al. (2009)	Vienna (A)	20000	1	2.5	6.98	-	0.46	37	49	36	108	145
			5	2.5	6.76	-	0.2	18	16	22	35	51
			10	2.5	6.89	-	0.21	20	16.2	23	23	48
			Background	-	-	-	0.17	68	13.1	22	20.5	52.5
Viard et al. (2004)	Nancy (F)	40000	1	5	7.5	7	0.85	-	-	-	200	263
			5	5	-	-	0.38	-	-	-	60	120
			20	5	-	-	0.33	-	-	-	37	120
			Background	-	-	-	-	-	-	-	-	-
Viard et al. (2004)	Nancy (F)	60000	1	5	7.2	4	-	-	-	-	-	-
			5	5	-	-	0.35	-	-	-	78	98
			20	5	-	-	0.2	-	-	-	20	45
			Background	-	-	-	-	-	-	-	-	-
Stevovic et al. (2010)	Pancevo (SRB)	60000	5	7.5	-	-	4	11	-	19	125	-
			5	22.5	-	-	1.5	5	-	9.4	85	-
			15	7.5	-	-	-	-	-	-	13.9	-
			Background	-	-	-	-	-	-	-	-	-
Deska et al. (2011)	Sidlce E30 (PL)	9000	2	10	5.43	1.76	0.3	-	-	-	99	-
			2	40	-	-	0.2	-	-	-	119	-
			Background	-	-	-	0.29	-	-	-	24	-

Tab. S1: (continued) Loss of ignition (LOI), pH and metal concentrations in road side soils at different depth and distance from road determined by different authors.

Reference	Location	AADT	Distance	Depth	pH	LOI	Cd	Cr	Cu	Ni	Pb	Zn
			m	cm	(CaCl)	%	mg kg <sup>-1</sup>					
Pihl and Raaberg (2000)	Rud (DK)	22000	3	1	-	-	-	41	-	-	191	314
			3	6	-	-	-	28	-	-	223	240
			3	20	-	-	-	24	-	-	83	119
			6	1	-	-	-	32	-	-	74	89
			20	1	-	-	-	28	-	-	42	53
			Background	-	-	-	-	-	-	-	-	-
Pihl and Raaberg (2000)	Vejenbrod (DK)	29000	3	1	-	-	-	3	-	-	6	25
			3	6	-	-	-	1	-	-	1	5
			3	20	-	-	-	2	-	-	1	6
			6	1	-	-	-	7	-	-	7	24
			20	1	-	-	-	14	-	-	11	33
			Background	-	-	-	-	-	-	-	-	-
Garcia et al. (1996)	San Sebastian (E)	19200	0.2	2.5	7.8	7	1.72	23	162	54	1453	2618
			3.2	2.5	7.6	6.2	0.22	40	34	60	63	113
			Background	-	-	-	-	-	-	-	-	-
Garcia et al. (1996)	San Sebastian (E)	9500	0.2	2.5	8.1	4.2	0.9	32	121	51	727	495
			3.2	2.5	7	10.6	0.24	68	58	85	98	186
			Background	-	-	-	-	-	-	-	-	-
Garcia et al. (1996)	San Sebastian (E)	4000	0.2	2.5	7.6	10.6	0.4	20	45	23	327	286
			3.2	2.5	6.9	24.6	0.41	36	93	25	83	279
			Background	-	-	-	-	-	-	-	-	-
Garcia et al. (1996)	San Sebastian (E)	11000	0.2	2.5	7.8	5	0.34	18	86	25	303	262
			3.2	2.5	7.9	5.2	0.24	26	30	35	87	96
			Background	-	-	-	-	-	-	-	-	-
Garcia et al. (1996)	San Sebastian (E)	4000	0.2	2.5	8	2.7	0.16	31	23	53	55	125
			3.2	2.5	7.7	3.1	0.14	34	18	51	46	108
			Background	-	-	-	-	-	-	-	-	-
Steiner et al. (2007)	Burgdorf near Bern (CH)	17000	0.5	2.5	-	-	1.4	-	60	-	375	390
			0.5	7.5	-	-	1.2	-	60	-	300	350
			0.5	15	-	-	1.2	-	50	-	250	290
			5	2.5	-	-	0.02	-	30	-	25	50
			Background	2.5	-	-	0.02	-	50	-	25	50
Modlingerova et al. (2012)	Prague (CZ)	20000	1	12.5	6.8	2.18	0.45	36.4	19.1	21.5	23.5	106
			Background	12.5	-	-	0.51	43.3	19.7	20.5	14.4	95.3
Ward (1990)	Central England (GB)	1E+05	1	1	5.7	9.95	8.3	278	48	240	-	870
			Background	-	-	-	0.4	69	14	28	-	68
Ward (1990)	Birmingham (GB)	75000	1	1	5.7	9.95	10.7	191	54	275	-	675
			Background	-	-	-	0.4	69	14	28	-	68

Tab. S1: (continued) Loss of ignition (LOI), pH and metal concentrations in road side soils at different depth and distance from road determined by different authors.

Reference	Location	AADT	Distance	Depth	pH	LOI	Cd	Cr	Cu	Ni	Pb	Zn
			m	cm	(CaCl)	%	mg kg <sup>-1</sup>					
Ward (1990)	London (GB)	1E+05	1	1	5.7	9.95	9.1	290	46	314	-	940
			1	7	-	-	0.8	88	23	108	-	260
			1	15	-	-	0.7	73	23	67	-	172
			Background	-	-	-	0.4	69	14	28	-	68
Jankaitė et al. (2008)	Žiežmariai (LT)	-	0.1	10	-	-	-	26.4	13.4	19.4	36.5	74.6
			2	10	-	-	-	39.5	8.6	10.8	35.7	84.7
			5	10	-	-	-	49.9	3.4	8.2	6.1	40.1
			Background	-	-	-	-	30	8.1	12	15	26
Jankaitė et al. (2008)	Vilnius-Panevėžys (LT)	-	0.1	10	-	-	-	59.4	21.8	11.4	37.4	175
			2	10	-	-	-	15.8	16.7	10.3	39.8	89.3
			5	10	-	-	-	4.9	11.8	15.7	23.6	24.5
			Background	-	-	-	-	30	8.1	12	15	26
Jankaitė et al. (2008)	Vilnius-Varėna (LT)	-	0.1	10	-	-	-	40.8	1.9	9.4	31.5	32.4
			2	10	-	-	-	9.9	7.1	15.6	18.6	40.2
			5	10	-	-	-	5.9	8.5	9.9	17.9	49.1
			Background	-	-	-	-	30	8.1	12	15	26
Jankaitė et al. (2008)	Vilnius-Utena (LT)	-	0.1	10	-	-	-	6.5	9.1	11.5	14.5	59.8
			2	10	-	-	-	5.1	8.2	16.9	11.9	34.3
			5	10	-	-	-	34.7	9.4	16.4	12.6	35.7
			Background	-	-	-	-	30	8.1	12	15	26
Jankaitė et al. (2008)	Vilnius-Prienai (LT)	-	0.1	10	-	-	-	8.2	11.8	17.4	22.9	171
			2	10	-	-	-	5	11.7	10.9	22.4	55.1
			5	10	-	-	-	10.4	8.9	18.2	18.4	38.9
			Background	-	-	-	-	30	8.1	12	15	26

Tab. S2: Electrical conductivity (EC), pH and metal concentrations of soil solution in road side soils at different distances from road at 50 cm soil depth determined by different authors.

Reference	Location	AADT	Distance	pH	EC	Cd	Cr	Cu	Ni	Pb	Zn
			m	(CaCl)	$\mu\text{S cm}^{-1}$	$\mu\text{g L}^{-1}$					
Kluge and Wessolek (2012)	Berlin (D)	100000	2.5	7.8	5000	1.6	5.6	156.4	8.8	8.2	51.3
			5	7.8	700	0.5	0.8	27.8	4.2	2.6	31.9
			10	5	300	1.5	3.6	50.3	9.1	13.4	258.4
Kocher and Wessolek (2002)	Hannover (D)	70000	1	7.45	422	0.2	1	5	1.1	0.98	13
			2.5	6.45	630	0.47	3.1	13.1	6	1.69	41
			5	5.04	449	1.24	1.2	4.9	4.6	0.63	123
			10	4.8	732	3.17	2.3	13.2	9.6	0.99	397
Kocher and Wessolek (2002)	Hannover (D)	70000	1	7.17	1479	0.79	5.5	70	10.2	2.02	181
			2.5	6.3	634	0.3	4.3	59.7	5.5	2.1	77
			5	7.07	402	0.13	1.8	11.2	3.4	0.81	14
			10	7.06	295	0.11	3.1	13.9	3.7	1.38	19
Kocher and Wessolek (2002)	Hannover (D)	50000	1	7.64	868	0.09	3.7	12.4	1.2	0.65	10
			2.5	7.12	458	0.2	2.7	26.2	3.8	2.34	12
			5	5.03	1440	8.71	2.9	14	21.9	1.97	701
			10	6.64	178	0.13	0.9	13.8	4.6	0.63	21
Kocher and Wessolek (2002)	Berlin (D)	90000	1	8.05	4470	0.16	7.3	85.1	4.6	5.05	36
			2.5	7.96	5576	0.23	3.4	72.1	5.8	2.57	44
			5	7.72	2728	0.1	1.2	16.1	1.6	0.96	16
			10	4.5	233	0.72	3.6	23.4	10.7	3.56	213
Kocher and Wessolek (2002)	Celle (D)	20000	1	7.82	1204	0.07	2.3	6.2	1.4	0.22	16
			2.5	7.57	703	0.11	1.4	7.7	2.4	0.63	14
			5	7.06	218	0.09	1.6	10.4	1.6	0.94	19
			10	6.72	149	0.12	2.1	12.5	2.1	0.78	29
Kocher and Wessolek (2002)	Celle (D)	20000	1	7.52	1313	0.08	1	11.4	2	0.81	14
			2.5	7.86	991	0.1	2.2	7	2.6	0.54	17
			5	7.55	558	0.08	1.3	14.7	2.9	0.41	20
			10	4.83	147	0.43	5.2	18.6	4.7	0.99	258
Kocher and Wessolek (2002)	Braunschweig (D)	20000	1	7.53	1263	0.04	1.3	5.2	1.2	0.52	7
			2.5	6.18	475	0.09	4.3	8.7	2.7	0.91	13
			5	7.16	448	0.07	1.3	7.2	1.3	0.73	9
			10	6.93	674	0.13	3.2	7.3	14.5	0.86	48
Kocher and Wessolek (2002)	Celle (D)	20000	1	7.37	1125	0.07	1.4	9.6	1.4	0.62	12
			2.5	7.81	764	0.04	1.1	11.5	1.4	0.45	8
			5	6.61	1156	0.15	1.5	3.2	4.4	0.22	20
			10	6.74	800	0.09	1.4	3.6	5.8	0.69	13
Bäckstrom et al. (2004)	Svanenberg (S)	7400	4	6.21	2690	0.55	-	6.5	-	0.185	17.5
Bäckstrom et al. (2004)	Norsholm (S)	15600	4	7.6	2950	0.01	-	17	-	0.5	5

Tab S3: Metal concentrations and pH values of the transect at the AVUS embankment (T) at different depth and distance from road.

Metal	Distance (m)	Depth (cm)	Pseudo-total concentration (mg kg <sup>-1</sup> )				
			Min	Max	Mean	Median	SD
Zn	2.5	0-10	205	295	292	258	100.19
		10-25	49	113	247.4	95	35.57
	5	0-10	166	475	292	277	100.19
		10-25	76	236	169.5	163.7	51.29
	7.5	0-10	156	626	263.0	238.5	132.55
		10-25	51	387	190.5	199.8	105.23
Cd	2.5	0-10	0.51	3.3	1.14	0.8	1.64
		10-25	0.3	0.62	0.85	0.55	0.27
	5	0-10	1.4	6.41	3.34	3.29	1.64
		10-25	0.75	3.19	2.34	2.17	0.83
	7.5	0-10	1.5	10.4	3.52	3.17	2.53
		10-25	0.3	6.33	2.36	2.78	1.87
Pb	2.5	0-10	190	357	219.8	245	66.95
		10-25	15	85	256.2	74	62.09
	5	0-10	153	386	219.8	207.5	66.95
		10-25	25	102	57.5	59.4	20.51
	7.5	0-10	94	240	156.2	147	49.92
		10-25	22	122	60.5	64.3	33.79
Ni	2.5	0-10	7.7	13.2	10.72	11.4	2.61
		10-25	0.4	4.18	10.98	3.53	2.05
	5	0-10	7.0	14.3	10.72	10.75	2.61
		10-25	3.75	7.99	6.05	5.98	1.69
	7.5	0-10	4.9	26.6	10.14	8.75	6.20
		10-25	2.9	11.4	5.50	6.4	2.88
Cu	2.5	0-10	48.3	77	71.64	74	19.07
		10-25	7.3	21.2	67.46	19.4	12.59
	5	0-10	49.4	103	71.64	65.5	19.07
		10-25	19.3	45.4	35.3	34.34	9.86
	7.5	0-10	36.3	182	68.21	56	41.22
		10-25	9.8	80	37.75	40.87	22.32
Cr	2.5	0-10	20.1	27.5	22.54	25.4	5.51
		10-25	3.6	15.4	24.44	10.55	2.79
	5	0-10	16	31.6	22.54	21.6	5.51
		10-25	6.93	18.8	14.45	13.23	3.80
	7.5	0-10	12.6	42.9	19.08	16.25	9.06
		10-25	5.4	22.8	11.85	13.62	6.13



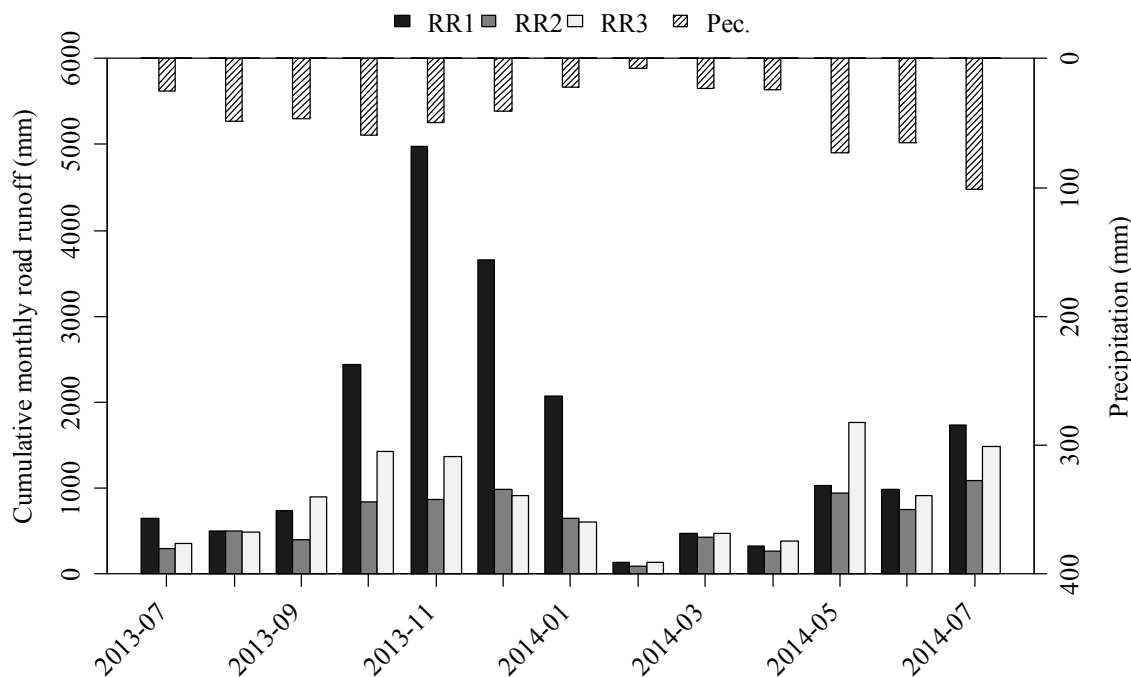

Fig. S1: Cumulative monthly road runoff volumes (mm) determined with the three runoff lysimeters (RR1-RR3).

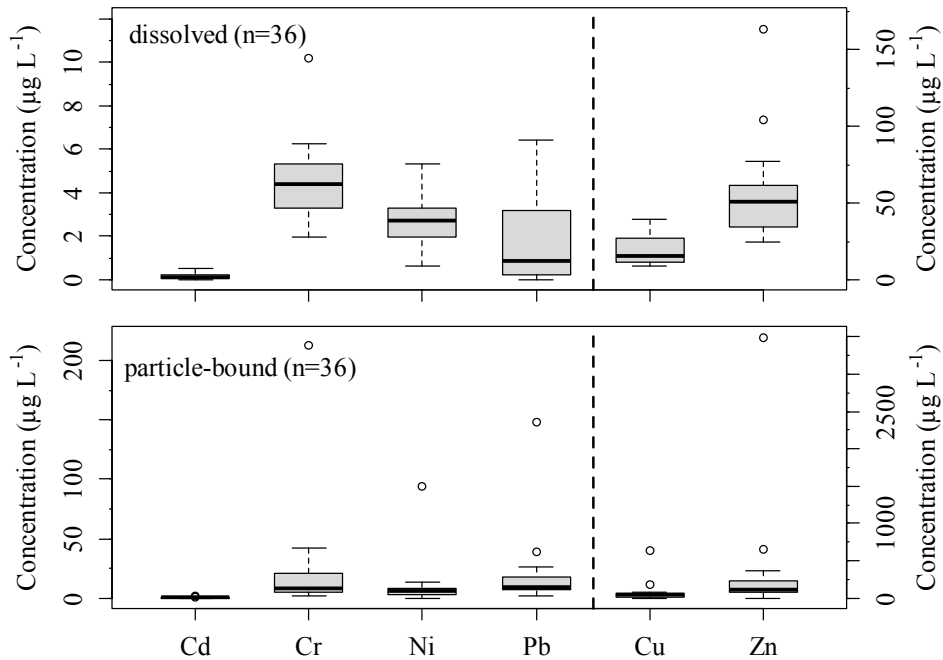

Fig. S2: Dissolved (top) and particle-bound (bottom) metal concentrations in road runoff of the A115 (median, min., max., upper and lower quartile and outliers). Note: the bold dashed line separates the plot into two different y-scales.