

# Attainment and Maintenance of Normal Stature with Alkali Therapy in Infants and Children with Classic Renal Tubular Acidosis

ELISABETH MCSHERRY and R. CURTIS MORRIS, JR., *Departments of Pediatrics and Medicine, University of California, San Francisco, California 94143*

**ABSTRACT** Growth was evaluated in a group of 10 infants and children with familial or idiopathic classic renal tubular acidosis in whom alkali therapy was initiated at ages ranging from 8 days to 9.5 yr and administered at dosage schedules documented to sustain correction of acidosis in at least four prolonged observation periods on the Pediatric Clinical Research Ward. When alkali therapy was begun, six patients (four infants and two children) were stunted (height < 2.5 SD below mean). Of the four who were not, two infants were too young (<2 wk of age) to have become stunted, and two children had been documented earlier to be nonacidotic. At the start of alkali therapy, the heights of the patients correlated inversely with the maximal possible duration of prior acidosis.

With sustained alkali therapy: (a) each patient attained and maintained normal stature; (b) the mean height of the 10 patients increased from the  $1.4 \pm 4$  to the  $37.0 \pm 33$  percentile (of a normal age- and sex-matched population); (c) the mean height reached the 69th percentile in the eight patients whose heights could be analyzed according to parental prediction (Tanner technique); (d) the rate of growth increased two- to threefold, and normal heights were attained within 6 mo of initiating alkali therapy in the stunted infants and within 3 yr in the stunted children; (e) the height attained correlated inversely with the maximal possible duration of acidosis (before alkali therapy) only in those patients in whom alkali therapy was started after 6 mo of age, and not in those treated earlier.

The amount of alkali required to sustain correction of acidosis increased substantially during the course of treatment in each patient. The maximal alkali requirement ranged from 4.8 to 14.1 meq/kg per day, and in

each patient its amount was determined principally by the magnitude of renal bicarbonate wasting.

## INTRODUCTION

In infants and children with persisting classic (Type 1) renal tubular acidosis (RTA)<sup>1</sup> (1–19), the occurrence of stunted growth is characteristic (20–33). In these patients, persisting acidosis might be critical to the causation of stunted growth (21–24, 27, 28, 31). If this is so, and if acidosis in these patients occurs only because the kidney fails to excrete acid at a rate equal to that at which nonvolatile acid is presumed to be normally endogenously produced, provision of alkali therapy to these patients in amounts of 1–3 meq/kg per day should both sustain correction of acidosis (11, 14, 19, 30, 34–37) and induce correction of stunted growth, i.e., induce the occurrence of normal stature. But in the only long-term prospective study of children with clearly defined classic RTA, stunted growth apparently persisted despite provision of alkali therapy in amounts of 1–3 meq/kg per day (30). Indeed, in some infants and children with classic RTA, in particular those whose height percentiles are less than the 3d percentile, the “pattern of growth” is said to be unaffected by alkali therapy in the amount of 2–3 meq/kg per day (19). And in a recently described infant girl with classic RTA, the occurrence of stunted growth was not prevented by alkali therapy administered in the amount of 2.5 meq/kg per day, even though this dosage was initiated on the third day of life (32). Therefore, in children with classic RTA, either acidosis is not critical to the causation of stunted growth (33) or provision of alkali therapy in the amount of 1–3 meq/kg per day will not predictably sustain correction of acidosis (31). In many infants with apparently classic RTA described in the older literature, several times this dosage of alkali was required to correct acidosis (2, 38–47). In at least a few infants and children with clearly defined classic RTA, in whom urinary excretion of net base has been greater than 3

<sup>1</sup>Abbreviation used in this paper: RTA, renal tubular acidosis.

Received for publication 14 February 1975 and in revised form 3 October 1977.

meq/kg per day at normal (and reduced) plasma bicarbonate concentrations (renal bicarbonate wasting [15–17]), sustained correction of acidosis has perforce required alkali therapy in amounts greater than 3 meq/kg per day (15–17).

In the present study of 10 infants and children with classic RTA, who were either short or frankly stunted when alkali therapy was started, we have investigated: (a) the amount of alkali therapy required to sustain correction of acidosis; (b) the immediate and continuing effect on growth of correcting alkali therapy; and (c) the contribution of renal bicarbonate wasting to the alkali requirement.

## METHODS

10 infants and children with classic RTA were studied on the Pediatric Clinical Research Ward (Table I). Each patient had symptoms and signs characteristic of RTA (1, 2, 6, 7, 11, 22, 23). None had hyperaminoaciduria.

In six patients, RTA occurred as an apparent Mendelian dominant trait affecting members of three (III-1) and four (IV-8, IV-10, IV-11, IV-13, IV-15) successive generations of two unrelated kindreds (see Appendix). RTA was considered to be idiopathic in the four other patients; they are designated ID-1, ID-2, ID-3, and ID-4. Their parents and siblings had no history suggestive of RTA or hyperchloremic acidosis or evidence of impaired renal acidification, as judged from measurements of urinary pH and excretion rates of  $\text{NH}_4^+$  and titratable acid. The initials of the patients' names are given in Table I.

*Informed consent and special precautions.* Both parents of each child studied were informed of the purpose, character, and risks of the studies and were specifically informed that catheterization of the bladder involved a small but finite risk of infection of the urinary tract. The investigators offered to assume continuing responsibility for the management of the child's illness, irrespective of whether the parents gave consent for any of the studies proposed. At the termination of each catheterization, urine collected from the catheter was cultured. During the 48 h immediately after catheterization, brisk water diuresis was maintained as a prophylaxis against urinary tract infection. Urine was again cultured 48 h after catheterization. In none of the patients did clinical evidence of pyelonephritis occur or urine cultures become positive.

*Acid excretion during acidosis (Table I).* In all patients, spontaneous hyperchloremic acidosis was documented at the time RTA was diagnosed and therapy initiated. In all but two patients, observations of renal acid excretion were made during spontaneously occurring acidosis, either at time of diagnosis or when therapy was insufficient to prevent the occurrence of acidosis. IV-8, at ages 1 mo (48) and 12 yr, and IV-13, at age 2 wk, received oral loads of  $\text{NH}_4\text{Cl}$ , 0.1 g/kg (6).

*Bicarbonate reabsorption during corrected acidosis.* The relationship between plasma bicarbonate concentration and renal reabsorption and excretion of bicarbonate was examined at normal plasma bicarbonate concentrations. For at least 2 wk before each study, appropriate therapy had maintained the plasma bicarbonate concentrations at normal levels and serum potassium at 3.8 meq/liter or greater. Details of this kind of study have been described (15).

*Evaluation of growth (Figs. 1–4).* In the Clinical Research Center, body length (infants < 18 mo, recumbent) or height (children over 18 mo, standing) was measured in triplicate at the time of diagnosis of RTA and repeated thereafter during corrective alkali therapy by at least two observers, including a

research nurse and a physician. If the three measurements did not agree within 0.25 cm, they were repeated until they did. Similar measurements were also made in patient IV-13 9 mo before alkali therapy was initiated and in ID-1 5 yr before sustained corrective therapy was initiated. A number of the recorded measurements were made by referring physicians: in IV-13, III-1, ID-3, ID-4, before their diagnosis of RTA in the Pediatric Clinical Research Center; in ID-2, IV-8, IV-11, and IV-10, after diagnosis but before alkali therapy was adjusted or initiated in the Pediatric Clinical Research Center.

*Correction of acidosis, alkali requirement (Table II).* Each patient was observed on at least four occasions for periods of 6–14 days on the Clinical Research Ward on a standard metabolic diet (fixed normal intake of Na, K, Ca, protein, and calories). Venous  $\text{CO}_2$  content and, in some instances, arterial plasma bicarbonate concentration were measured each morning in the fasting state, before the first morning dose of alkali. Alkali therapy was administered at a dosage schedule (usually similar to that prescribed as an outpatient) that sustained correction of acidosis, as judged by repeated demonstration of normal values of venous  $\text{CO}_2$  content or plasma bicarbonate concentration. In young infants (<6 mo), total alkali dosage was divided into equal portions and administered every 4 h with each feeding. In older infants and children, if their requirement was 10 meq/kg per day or less, alkali was administered four times per day in equal amounts. If their daily requirement exceeded 10 meq/kg per day, alkali therapy was administered five times per day, the first morning dose and the last evening dose being 125–150% of the other three equal doses. In three patients, measurements of venous  $\text{CO}_2$  content were also made an hour after the noon dose and during the late afternoon, after several doses of alkali therapy. In two of the three patients studied, all spontaneous voidings during waking hours were collected individually to measure maximal and minimal rates of bicarbonate and base excretion. Otherwise, urine was collected in 24-h pools by methods previously described (15).

*Bicarbonate excretion after prolonged alkali therapy (Table III).* In eight rapidly growing patients treated with alkali therapy for 11 mo to 6 yr, in whom the absolute dose of alkali therapy had not been changed for 1–6 mo, the same absolute dose of alkali was continued under controlled metabolic conditions and the urinary excretion of net base, calcium, and other electrolytes was measured. Then, in five of the eight patients, the effect of abruptly changing the dose of alkali therapy on the urinary excretion of these substances was also investigated: In four studies, the amount of alkali therapy was abruptly reduced after correction of acidosis had been demonstrably sustained for a period of months; in one study (ID-3), mild acidosis, documented to have been present for at least 1 mo, was corrected by abruptly increasing the amount of alkali therapy. Throughout each study period and for 3 days before, each patient ingested a diet of constant and known electrolyte composition. Dietary calcium intake was normal (63). Blood samples were drawn in the morning before breakfast, at least 12 h after the last dose of bicarbonate. Blood for determination of plasma renin was drawn between 8:00 and 9:00 a.m., when the patients had been fasting and recumbent for at least 3 h.

*Inadequacy of prolonged dose of alkali therapy in excess of 4 meq/kg per day (Table IV).* In each of six children in whom the absolute dose of alkali had remained unchanged for periods ranging from 3 to 10 mo (and hence was not adjusted upward with weight gain), and in whom acidosis occurred as an outpatient, the prescribed dose of alkali was continued under controlled metabolic conditions. The acid-base status of each patient was evaluated for periods of 4–10 days in the Clinical Research Ward on a standard metabolic diet. Venous  $\text{CO}_2$  content and, in some instances, arterial plasma bicarbo-

TABLE I  
Clinical and Physiological Characteristics of Infants and Children with Classic Renal Tubular Acidosis

Patient,* age at start of alkali therapy, (duration of therapy)	Sex of patient	Age when measured	Status of renal acidification							
			Arterial blood			Urine				
			pH	P <sub>CO<sub>2</sub></sub>	HCO <sub>3</sub> <sup>-</sup>	pH <sub>min</sub>	TA	NH <sub>4</sub> <sup>+</sup>	Net acid	C <sub>in</sub> †
	mm Hg	meq/liter		μmol/min per 1.73 m <sup>2</sup>			ml/min per 1.73 m <sup>2</sup>			
Normal values§		Infants (0-12 mo) Children				4.90±0.03 <5.90	62±4.9 >31	57±4.3 >27	119 >58	52-134
IV-8 (R. C.), 3½ yr (9 yr)	M	1 mo 3½ yr 12½ yr	— — 7.32	— — 35	(11) <sup>¶</sup> (17) 17.5	6.5 <sup>¶</sup> >7.0 <sup>¶</sup> 7.20	14 — 6.2	31.5 — 18.3	— — (23.8)	— — 128.4
IV-11 (D. C.), 6 wk (5 yr)	F	4 yr	—	—	(18)	7.37	—	13.0	(34.9)	114.6
IV-10 (M. S.), 2½ yr** (7 yr)	M	2½ yr 5 yr††	— 7.20	— 27.5	(10) 10.4	>7.0 <sup>¶</sup> 6.79	— 19.4	— 32.9	— 46	— 98.7
IV-13 (J. S.), 10 mo (1 yr 6 mo)	F	2 wk 10 mo††	7.28 7.27	36 37	16.3 16.4	6.1 6.68	19.6 18.9	28 38.7	47.6 55.2	— 106.5
IV-15 (H. S.), 10 days (2 yr 4 mo)	F	2 mo 10 mo	7.23 7.34	— 32.8	[18.4] <sup>¶</sup> 17.2	7.0 6.95	2.9 12.5	12.5 25.2	1.5 6.9	— 106.9
III-1 (D. P.), 2 yr (2 yr 7 mo)	F	2 yr††	7.32	22	11.0	6.7	15.1	59.9	—	125.8
ID-1 (C. G.), 4 mo (14 yr)	F	6 yr	7.27	—	(10)	6.65	17.3	17.1	—	93.1
ID-2 (P. B.), 2½ mo (5 yr 6 mo)	F	2 yr	7.18	28.8	10.4	6.62	8.0	19.1	22.4	77.5
ID-3 (V. V.), 4½ mo (6 yr)	F	4½ mo†† 3½ yr	— 7.24	— 36.6	( 8.7) 15.2	7.22 7.13	11.5 1.0	87.8 12.0	(32.6) (33.1)	56.3
ID-4 (T.L.), 3 days (4 yr 6 mo)	F	8 days 1 mo 2¾ yr	7.06 7.35 7.31	24 33.5 36	6.6 17.8 17.6	>7.0 6.96 7.33	— 5.0 10.8	— 24 22.9	— (28.2)	55.0

Abbreviations: TA, titratable acid; NH<sub>4</sub><sup>+</sup>, ammonium.

\* IV-8, IV-10, IV-11, IV-13, and IV-15 are all members of the same generation of the same kindred, family A (Appendix), reported by Randall and Taggart (48, 49); III-1 is a member of the third generation of family B (Appendix), data from the proband of which has been published (10). ID-1 through ID-4 designate patients judged to have idiopathic RTA. Each has been previously reported on: (ID-1 (10, 50), ID-2 (13, 15), ID-3 (15), and ID-4 (15)).

† Values, obtained during acute bicarbonate titration studies, represent the mean of at least three successive clearance periods (after plasma bicarbonate concentration had been maintained in the normal range for at least 2 wk).

§ Normal values of urinary pH, TA, and NH<sub>4</sub><sup>+</sup> were derived from measurements made after a single oral dose of NH<sub>4</sub>Cl, 75 meq/m<sup>2</sup> in infants (51) and in children (ages 4-13 yr) (52). Values in infants are mean±SE. Normal values for net acid excretion are calculated from the sum of the normal values for the excretion rates of TA and NH<sub>4</sub><sup>+</sup>. Normal values±SD for Plasma HCO<sub>3</sub><sup>-</sup> in infants are calculated from data of Winters (53); normal values±SE for children >2 yr, from Edlemann et al. (51). Normal values for C<sub>in</sub> for infants: (1949 *J. Clin. Invest.* 28: 1144). Values of pH are minimal ones observed; values for TA, NH<sub>4</sub><sup>+</sup>, and net acid, the maximal ones observed. Net acid excretion = the sum of the excretion rates of titratable acid and ammonium minus the excretion rate of bicarbonate. Values in parentheses indicate net base excretion.

¶ Values in parentheses indicate carbon dioxide content of venous serum; value in brackets indicates venous plasma bicarbonate.

¶ Values of pH were determined with nitrazine paper. Values of TA and NH<sub>4</sub><sup>+</sup> were calculated from 24-h excretion data (48).

\*\* Although acidosis was diagnosed at age 2½ yr, alkali therapy was not started until age 5 yr.

†† Values obtained after long-term pre-existing acidosis and presumed total body potassium depletion, as judged by hypokalemia in the presence of acidosis.

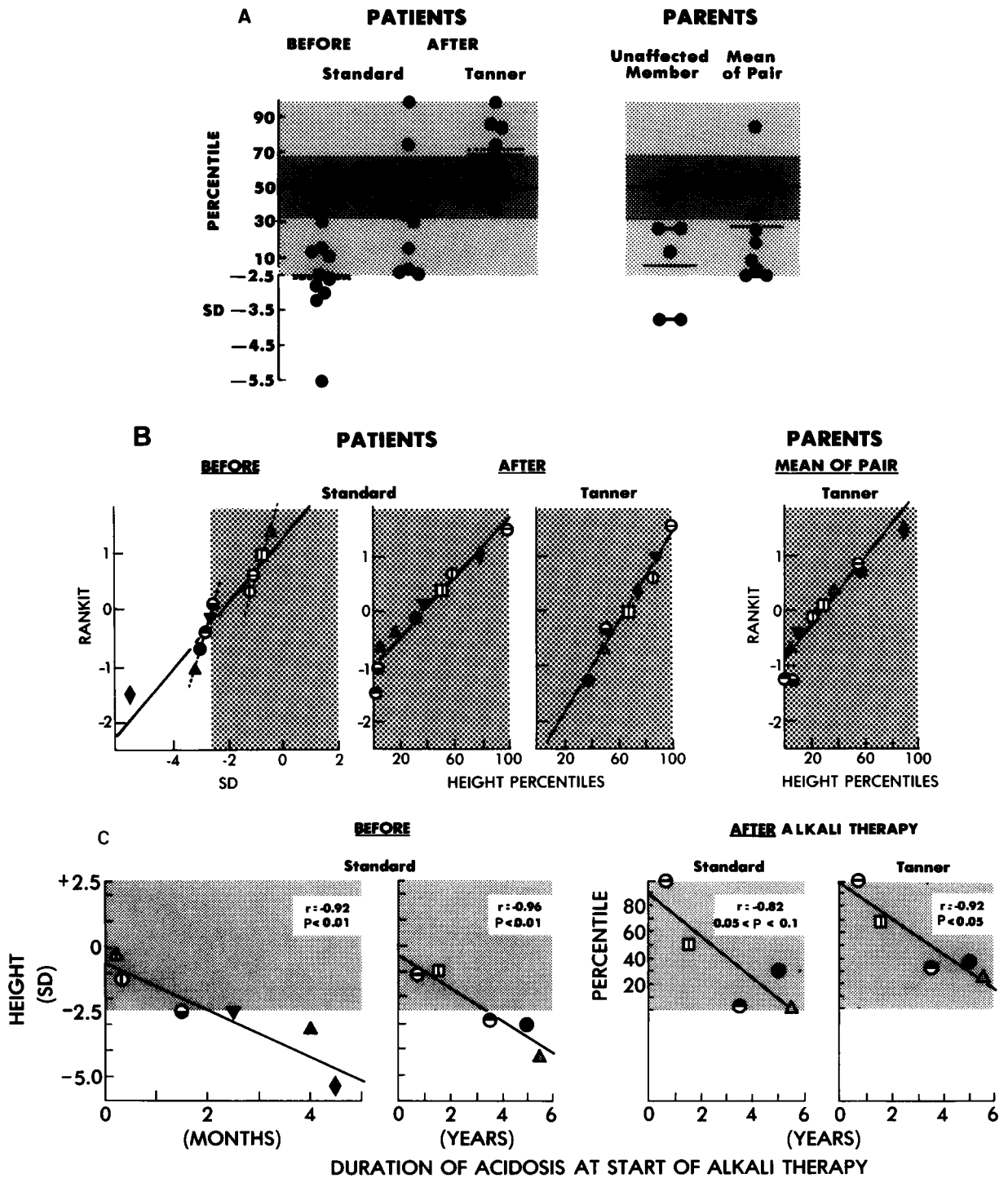

FIGURE 1 (A) The effect of alkali therapy on height in 10 children with classic RTA. Height is expressed in percentiles relative to age- and sex-matched populations. "Standard" reference populations for patients and for unaffected parents of patients with familial RTA are those reported by Reed and Stuart (26). Tanner values for patients' height potential (predicted from mean parental height) ("after") and those for mean parental height are derived as described by Tanner (55). Limits of the lightly shaded area indicate  $\pm 2.5$  SD from the mean; the darker area,  $\pm 0.5$  SD. Solid horizontal lines indicate the mean for the group; dashed horizontal lines, the median. Each of two unaffected parents with two progeny affected with familial RTA (IV-8 and IV-11; IV-10 and IV-13), and the parent pair of which each is a member are doubly weighted, as indicated by the horizontal dumbbell symbol ( $\bullet\text{---}\bullet$ ). "Mean of pair" refers to the mean parental height of the mother-father pair.

(B) Distributions of height percentiles (or standard deviations from normal mean height [SD]) in 10 infants and children with classic RTA, before and after alkali therapy, and in their parents. Plotted is the relationship between height percentile (or SD) and rankit, the mean normal deviate test (56), for each affected patient before and after alkali therapy, and for their parents. A unique symbol denotes the height percentile (or SD) of each affected child and the mean height percentile of that child's parents. Rankits, also termed "ranked normal deviates," are averaged standardized scores for the highest to the lowest variate of a group of size  $n$ , and are assigned from a table of rankits (57). With an ideal normal distribution, all points lie on a straight line without segregation, when rankits are plotted against the ranked values of the variable on a standard arithmetic scale graph. At rankit value of 0,  $x =$  the value of the group mean:  $\pm 1$  is  $\pm$ SD. Circles denote affected children of family IV; the square, the affected child of family III; the diamond, ID-3; and triangles, the other children with idiopathic RTA. The four open symbols denote the two patients from each of two age-treatment groups who were acidotic for a substantially shorter time than the other members of their age-treatment group. Of the six patients in whom alkali therapy was initiated before 6 mo of age (the early infancy age-treatment group), two ( $\odot$  IV-15 and  $\triangle$  ID-4.) were treated at  $<10$  days of age and hence were too young to have become stunted. Of the four patients in whom alkali therapy were initiated after 6 mo of age (the older age-treatment group), two ( $\ominus$  IV-13 and  $\square$  III-1) had been documented to be nonacidotic at age 2 mo and 6 mo, respectively, 8 and 18 mo, respectively, before alkali therapy was started. Closed or partially closed symbols denote patients in whom the duration of acidosis before alkali therapy was longer than in the other members of their age treatment groups:  $\bullet$  IV-11,  $\blacktriangle$  ID-1,  $\blacktriangledown$  ID-2, and  $\blacklozenge$  ID-3, of the early infancy treatment group; and  $\bullet$  IV-8 and  $\bullet$  IV-10 of the older treatment group, both of whom were documented to be acidotic for 3.5 and 5 yr, respectively, before corrective alkali therapy was started. The overlapping symbols indicate one set of parents with two affected children and are assigned "tie" value rankits as directed by the test (56).

Before alkali therapy, the heights (SD) attained by the 10 patients do not lie on a straight line, but segregate into at least two clusters. Within each of the two clusters, the patients' height percentiles do lie on a straight line when assigned appropriate rankits (not shown). The mean height of the four patients whose heights make up the taller cluster, and in whom the duration of acidosis before alkali therapy was less than that of the other members of their age treatment group, was  $-0.95 \pm 0.33$  SD; all were small (height percentiles  $<30\%$ ), but none were stunted. The mean height,  $-2.82 \pm 0.29$  SD, of the five patients whose height percentiles make up the shorter cluster was significantly less than the mean height of the patients of the taller cluster ( $P < 0.001$ ); all members of the shorter cluster were stunted. The patient with the lowest height percentile, the value of which was outside even the cluster of the shorter heights, was the member of the early infancy treatment group in whom the maximal possible duration of acidosis was longest. She had been documented to be severely acidotic at age 3 mo.

After alkali therapy, the height percentiles attained by the eight patients who could be evaluated by the Tanner technique lie on a straight line with no evidence of deviation from normal distribution. The height percentiles of the 10 patients after alkali therapy relative to the standard reference population, and those of the parents, are also normally distributed, even though both the distributions appear to be slightly perturbed by the presence of  $\bullet$  and  $\bullet$  (affected children and their parents) in each group of height percentiles. In this family, the unaffected father is abnormally small, hence in these children, height is greatly diminished (but not subnormal), presumably on that basis. The normalcy of the distribution of the height percentiles of the 10 patients after alkali therapy (as evaluated by either the standard or the Tanner technique) and before therapy was confirmed by the W statistic of Shapiro and Wilk (58) (not shown).

The rank order of the patient's individual heights before therapy was not maintained after therapy. For six patients, the rank order of height increased; for four, it decreased. The greatest decrease in rank order occurred in ID-4, whose compliance with alkali therapy was least. The greatest increase in rank order occurred in ID-3 in whom compliance appeared complete and in whom mean parental height was greatest. ID-3 and ID-4 were alike with respect both to their ages and to the severity of their acidification defects when alkali therapy was initiated (in infancy).

(C) The height percentiles attained before and after alkali therapy as a function of the duration of acidosis preceding the initiation of alkali therapy, in two treatment groups: those in whom alkali therapy was started before 6 mo of age (extreme left) and those in whom alkali therapy was initiated after 6 mo (near left and right). The height percentile (or SD) (in reference to age- and sex-matched normal populations) attained by the patient is plotted against the maximal possible duration of acidosis before alkali therapy. (The duration between birth and initiation of alkali therapy for all patients, except IV-13 and III-1 [members of two kindreds], who were documented to have normal arterial pH and plasma bicarbonate concentration at ages 2 and 6 mo, respectively, and were not treated with alkali therapy until ages 10 mo and 2 yr, hence, having "durations" of 8 mo and 1½ yr, respectively.) Symbols denote individual patients, as in Fig. 1 B. ID-1 appears in both age treatment groups: in this patient, therapy was initiated at the age of 4 mo (extreme left, "before"  $\blacktriangle$ ), but metabolic acidosis continued as an outpatient (because only 10% of the dose of alkali prescribed was administered) until age 5½ yr, when stunting was present and continuously correcting alkali therapy was initiated (near left, "before"  $\triangle$ ). The height percentiles plotted for each patient are those immediately before the initiation of alkali therapy ("before") and at the time of the last evaluation ("after") with two exceptions: The height percentiles attained by ID-1 and IV-8 after therapy are those recorded at 9 yr of age, the oldest age permitting of the Tanner analysis.  $r$  values are coefficients of correlations. The regression line plotted for  $y$  as a function of  $x$  is calculated by the method of the least squares.

In the patients in whom alkali therapy was initiated before 6 mo of age, a significant inverse correlation obtained between the maximal possible duration of prior acidosis and the height percentiles attained before alkali therapy (extreme left). In these patients, who are in the early infancy treatment group, the height attained *after* alkali therapy did *not* correlate significantly with the maximal possible duration of prior acidosis (not shown:  $r = -0.20$ , standard;  $-0.33$ , Tanner). In those patients in whom alkali therapy was initiated after 6 mo of age, and who are in the late treatment group, a significant inverse correlation obtained between the height percentiles attained both "before" (near left) and "after" (extreme right) therapy and the maximal possible duration of prior acidosis. For the height percentiles attained after alkali therapy evaluated by standard reference population (near right),  $r = -0.82$ ;  $0.05 < P < 0.1$ . If the same value of  $r$  obtained in a group size of six rather than of five, this correlation would be significant ( $P < 0.05$ ).

TABLE II  
Requirement for Corrective Alkali Therapy in 10 Infants and Children with Classic Renal Tubular Acidosis

Patient	Age at onset of alkali therapy	Alkali therapy, interval after onset			
		<6 mo	<2 yr	6 mo-2 yr	>2 yr
<i>meq/kg per day</i>					
Early infancy	(days)				
IV-15*	10.0	3		5.3, 14.1	7.0, 14.1
ID-4*	8.0	4.8, 6.7		6.8, 10.1	5.1, 7.9
Late infancy	(mo)				
IV-13	10.0	6.2, 7.5		7.5, 10.0	—
ID-3	4.5	3.6, 9.7		2.9, 4.4	2.4, 4.4
ID-2	2.5	4.9, 7.8		1.5, 4.6	2.9, 4.9
ID-1*	4.0	2.9, 6.3		4.3, 6.3	3.5, 6.2
IV-11	1.5		Not known†		6.2, 9.0
Child-hood	(yr)				
III-1	2.0		3.1, 5.2		5.2, 9.6
IV-10	5.0		3.1, 6.0		3.0, 4.0
IV-8*	9.5		2.0, 4.4		4.4, 4.8

Each recorded value of alkali therapy is that dosage required to sustain correction of acidosis for an observation period of at least 6 days. In each patient, with the exception of ID-2, the lower value in the first interval of observation indicates the dosage of alkali therapy required initially.

\* Alkali therapy was administered at a dosage schedule adequate to sustain correction of acidosis from time of onset of therapy, with four exceptions: IV-15 received inadequate dosage from age 3-10 mo because of poor parental compliance and lack of follow-up; ID-4 had sporadic parental compliance with therapy; ID-1, from age 1 to 5.5 yr, received alkali therapy that was not continuously corrective, because the alkali medication received as an outpatient was 0.1 the potency prescribed; IV-8 received inadequate dosage for the first 6 yr of alkali therapy, as judged from venous CO<sub>2</sub> contents at another hospital.

† Although the dose of alkali was not known, correction of acidosis appears to have been fairly well sustained, as judged from venous CO<sub>2</sub> concentrations measured at another hospital.

nate concentration were measured each morning in the fasting state, before the first morning dose of alkali. Alkali therapy was administered in an amount and dosage schedule identical with that prescribed as an outpatient. Blood for determination of plasma renin was drawn between 8:00 and 9:00 a.m., when the patients had been fasting and recumbent for 3 h. Urine was collected in 24-h pools by methods described previously (15).

**Laboratory methods.** Laboratory determinations were carried out as described previously (8, 10).

## RESULTS

### Physiological classification of RTA

**Acid excretion during acidosis (Table I).** In each of 10 patients, urinary pH was inappropriately high during moderate as well as severe acidosis; excretion rates of urinary ammonium and titratable acid during acidosis

were subnormal except for the initially observed excretion rates of ammonium in III-1 and ID-3. During acidosis, in patients ID-3, ID-4, and IV-11, the rate of urinary excretion of bicarbonate exceeded the sum of the rates of titratable acid and ammonium, i.e., net base excretion occurred. IV-13 at age 2 wk did not have spontaneously occurring acidosis, although her response to NH<sub>4</sub>Cl-induced acidosis was abnormal. In all patients, the impairment in renal acidification had persisted. In all patients, glomerular filtration rate (inulin clearance) has remained normal.

**Bicarbonate studies.** In each of the 10 patients, the general relationship between plasma bicarbonate concentration and the renal reabsorption and excretion of bicarbonate was similar to that previously described in children and adults with classic RTA (4, 5, 9, 10, 15). The fractional excretion of bicarbonate ( $C_{\text{HCO}_3^-}/C_{\text{in}} \cdot 100$ ) at normal plasma bicarbonate concentrations ranged from 1.0 to 7.7. In two patients (ID-3 and ID-4),  $C_{\text{HCO}_3^-}/C_{\text{in}}$  was 6.8-7.6% over a broad range of plasma bicarbonate concentrations (10-30 meq/liter). A detailed presentation and analysis of the bicarbonate titration studies of these two patients has been published (15).

### Growth before corrective alkali therapy (Figs. 1-4)

#### GROUP

**Standard reference population analysis (Fig. 1).** The mean height of the 10 patients before adequate alkali therapy was initiated was in the 1.4th percentile ( $\pm 4$ ) of a normal population matched for age and sex. Four patients were not stunted (mean height  $-0.95 \pm 0.33$  SD); of these, two were too young for stunting to have occurred and two were documented at 2 and 6 mo of age to be nonacidotic, 8 and 18 mo before alkali therapy was started (Fig. 1b). Six patients were stunted; their mean height was  $-3.4 \pm 1.1$  SD.

**Tanner analysis (Fig. 1).** Analysis of growth by the Tanner technique requires that the ages of the children be between 2 and 9 yr. Since 7 of the 10 children were first diagnosed and treated in infancy, their heights before therapy could not be evaluated by the Tanner technique. For three children first diagnosed and treated in childhood and one child (ID-1) inadequately treated since infancy (ages 2, 3½, 5, and 5½ yr respectively), the mean height before initiating corrective therapy was  $-2.83 \pm 0.9$  SD.

#### INDIVIDUALS

In each of the two infants diagnosed at less than 2 wk of age and who, as a consequence, were too young for stunting to have occurred, body weight was less than that at the time of birth by 11.1% in ID-4 at 8 days and by

TABLE III

Physiologic Findings in Eight Rapidly Growing Children with Classic RTA and Bicarbonate Wasting, in Whom Correction of Acidosis Was Sustained with Chronic Alkali Therapy of Fixed Absolute Amount\*, the Effect of Abruptly Altering the Dose of Alkali (Five Patients)

Patient, age, (duration of all alkali therapy)	Alkali therapy		Duration	Urinary excretion†				Calcium	C <sub>creat</sub> ‡	Body weight	Blood vol/ plasma vol	Urine aldosterone	Serum K <sup>+</sup>	Plasma renin
	Dose	OP		Balance	Net base§	Sodium	Potassium							
	meq/kg per day	mo	days	meq/kg per day	meq/kg per day	meq/kg per day	meq/kg per day	ml/min	kg	ml/kg	µg/day per 1.73 m <sup>2</sup>	meq/liter	µg/ml per 3 h	
Normal values: Infants (12–24 mo)														
							<2¶				4–17		1.3–24.9§§	
Children (>2 yr)														
													1.1–10.3	
													3–6 yr	
IV-15	13.6	13/60	2	6	12.6±3.2	3.0±1.0	3.0±1.3	1.9±0.7	15.7±2.9	9.4±0.3		5.1±0.4		
17.5 mo (17.5 mo)	8.7	8/70	5	5	9.6±1.3	3.4±0.3	3.2±0.7	2.8±0.4	14.8±0.6	9.2±0.0				
					<0.05	NS	NS	<0.02	NS	NS				
IV-13	7.5	7/50	6	5	11.1±2.4	4.1±0.6	3.2±0.4	1.9±1.0	15.0±0.8	10.6±0.1	7.3	4.7±0.2	9.0, 5.1	
21 mo (11 mo)	3.1	3/10	6	6	5.5±0.7	4.3±0.6	2.9±0.4	5.7±1.3	17.0±2.1	10.5±0.1				
					<0.005	NS	NS	<0.01	NS	NS				
IV-11	8.8	6/24	4	4	9.0±1.2	4.9±0.5	3.3±0.5	3.5±0.7	25.7±5.7	14.7±0.2	14.3	4.5±0.2	4.5, 6.4	
4 yr 9 mo (4 yr 7½ mo)	3.0	2/0.8	3	3	6.7±0.6	4.1±0.3	3.9±0.9	5.2±0.7	26.2±2.2	14.8±0.1				
					<0.025	NS	NS	<0.01	NS	NS				
ID-4	7.3	2/0.5	1	3	7.3±2.1	8.1±0.7	3.7±0.7	0.9±0.1	16.2±1.5	12.1±0.3		4.5±0.2		
2 yr 10 mo (2 yr 10 mo)	2.0	0/2.0	3	3	2.6±0.2	4.9±0.9	2.2±0.4	1.8±0.5	13.9±0.1	11.8±0.1				
					<0.025	<0.01	<0.05	<0.05	NS	NS				
ID-3	4.8	0/4.8	1	4	3.6±0.2	6.7±1.3	4.7±0.8	2.0±0.3	18.2±2.4	14.1±0.3				
3 yr 5 mo (3 yr ½ mo)	6.9	0/6.9	6	6	1.6±0.7	8.3±1.8	2.0±0.8	0.7±0.2	20.6±3.3	13.8±0.2	12.8	3.7±0.3	13.1	
					<0.025	NS	<0.001	<0.001	NS	NS				
3 yr 8 mo (3 yr 3½ mo)	5.4	0/5.4	3	4	2.9±0.4	9.6±1.6	4.6±1.0	2.2±0.5	21.7±4.7	15.6±0.0		3.8±0.1		
IV-10	5.9	4/1.5	6	6	4.2±1.3	3.5±0.4	1.3±0.5	0.8±0.4	47.6±7.0	20.1±0.1		4.4±0.4		
6 yr 6 mo (1 yr 6 mo)														
IV-8	4.4	4/4.0	1	5	7.8±3.5	2.7±0.6	3.7±2.3	1.7±0.7	99.0±17.8	34.0±0.2	33.7	4.3±0.4	5.9, 19.7	
9 yr 6 mo (6 yr)														
IV-2	5.0	2.5/2.5	5	6	3.9±0.6	3.5±0.6	2.6±0.6	1.9±0.8	39.3±3.9	16.3±0.1				
5 yr 3 mo (5 yr)														

Abbreviation: OP, outpatient.

\* Seven children were growing at a supernormal velocity (Figs. 2 B, 3 B, 4 B); in the eighth child (IV-8), growth velocity was accelerating to 133% of the previous rate. ID-3 was an exception in whom correction of acidosis was not complete until the amount of alkali therapy was increased as indicated.

† Urinary excretion and creatinine clearance do not include values from the 24-h period immediately after the change in alkali dosage. All determinations are the mean±SD of three to six successive daily measurements.

‡ Net base excretion = the excretion rate of bicarbonate minus the sum of the excretion rates of titratable acid and ammonium.

§ Infants 12–24 mo: The normal values±1 SD cited are those derived from measurements of pH and P<sub>co2</sub> of arterialized blood (Albert and Winters [53]). Children >2 yr: normal values±SE are derived from measurements of pH and P<sub>co2</sub> of arterial blood (Edlemann et al. [51]). We cite no mean of normal

values for serum venous CO<sub>2</sub> content. This value can be assumed to be at least 1 meq/liter greater than plasma bicarbonate concentration derived as above. (E. J. Masoro and P. D. Siegel, 1971, Table 5-1. In Acid-Base Regulation: Its Physiology and Pathophysiology. W. B. Saunders Company, Philadelphia).

¶ The upper limit suggested to ensure adequacy of alkali therapy (11, 37, 59).

\*\* Blood and plasma volumes were determined by the [<sup>251</sup>I]albumin dilution technique. Normal values from Gibson and Evans (60).

†† Normal values from New et al. (61).

‡‡ Measured by modified Haber technique. Normal values (fasting, supine) from Stark et al. (62).

§§ Student's *t* test, *P* value.

¶¶ During sustained correction of acidosis, the mean value of arterial plasma pH for the three patients in whom it was measured (IV-13, IV-11, ID-4) (on three occasions for each patient) was 7.375±0.034 (1 SD).

**TABLE IV**  
**Physiologic Findings during Continued Administration of Alkali Therapy in Amounts Insufficient to Correct Chronic Acidosis in Six Rapidly Growing\* Infants and Children with Classic Renal Tubular Acidosis**

Patient, age, (duration of all alkali therapy)	Alkali therapy				Plasma HCO <sub>3</sub> <sup>-</sup> (venous CO <sub>2</sub> content) meq/liter	Blood pH (arterial)	Urinary excretion†				Blood vol/ plasma vol ml/kg	Urine aldo-sterone μg/day per 1.73 m <sup>2</sup>	Serum K <sup>+</sup> meq/liter	Plasma renin μg/ml per 3 h	
	Total Na <sup>+</sup> /K <sup>+</sup> meq/kg per day	Dose	Duration				Net base‡ meq/kg per day	Potas-ium meq/kg per day	Chloride meq/kg per day	Calcium mg/kg per day					C <sub>creat</sub> ml/min per 1.73 m <sup>2</sup>
			OP	OP											
Normal values: Infants (12–24 mo)															
					20.8±1.2 <sup>‡</sup>										
Children (>2 yr)															
					24.0±1.1										
IV-15															
1 yr 2 mo (1 yr 2 mo)	6.3	6.3/0	4	4	17.9±1.8 <sup>¶</sup> (17.0±1.9)	7.36, 7.39 7.33	2.2±0.6	7.4±1.2	2.9±0.3	3.1±0.5	2.1±0.6	50.4±9.0	13.4	4.7±0.2	1.3–24.9 <sup>§§</sup> 0–3 yr 1.1–10.3 3–6 yr
3 yr 11 mo (3 yr 11 mo)	6.9	6.9/0	10	7	— (20.5±1.8)		3.4±1.3	6.5±2.3	2.7±0.5	2.7±1.6	<2 <sup>¶¶</sup>	84.8±32	11.7	4.6±0.5	5.9, 7.6
IV-13															
1 yr ½ mo (3 mo)	5.3	5.3/0	3	6	19.9, 18.5 (17.0, 19.9)	7.38, 7.38	0.4±0.1	3.8±0.7	2.2±1.2	1.8±1.8	2.1±0.2	99.3±88.2	13.4	4.4±0.3	14.9–17.5 <sup>¶</sup>
2 yr 4 mo (1 yr 6 mo)	10.3	10.3/0	5.5	10	19.9 (19.6±2.7)	7.36	6.9±1.0	10.4±1.4	3.2±0.5	2.4±1.2	2.6±1.0	86.4±10.3	11.0, 9.5, 9.5	4.9±0.2	
2 yr 9½ mo (1 yr 11½ mo)	9.4	9.4/0	3	9	21.9 (21.0±1.1)	7.36	5.3±1.2	8.9±3.1	3.1±0.9	3.1±1.7	2.1±0.5	91.3±11.7	36.9, 13.5, 23	4.7±0.4	13.7–15.3 <sup>¶</sup>
V-II															
5 yr 5½ mo (5 yr 4 mo)	8.9	5.3/3.6	7	5	— (19.4±0.9)		5.8±0.5	9.0±0.9	3.8±0.2	3.7±0.5	3.5±0.6	86.6±24.3	25.8	4.4±0.2	3.8
III-1															
4 yr 9 mo (2 yr 9 mo)	8.3	8.3/0	4	6	20.8±0.8 (21.8)	7.37, 7.35 7.39	5.9±1.1	11.4±1.6	2.5±0.3	3.6±1.4	0.6±0.2	117.4±44.4	6.3, 3.9	4.3±0.2	2.6–9.0 <sup>¶</sup>
ID-4															
2 yr 9 mo (2 yr 9 mo)	5.6	1.5/4.1	6	3	— (21.1, 21.3)		4.5±1.7	4.3±1.0	7.6±0.8	2.9±0.4	1.8±0.6	50.4±6.0	38.9	4.1±0.1	36
ID-3															
3 yr 4 mo (3 yr)	4.3	0/4.3	3.5	6	— (20.9±0.5)		2.1±0.5	3.2±0.2	5.5±0.8	4.5±0.5	1.9±0.4	55.1±7.7		3.8±0.3	

Abbreviations: OP, outpatient.

\* The six patients were growing at supernormal velocities; five of the six were growing at nearly twice the mean velocity for their age- and sex-matched peers.

† All determinations are the mean±SD of 3–10 successive daily measurements.

‡–§§ See footnotes to Table III with like symbols.

¶ All values are the mean±SD of three to five measurements.

¶¶ Numbers connected by dashes indicate a range of three or four values.



9.2% in IV-15 at 10 days, an indication of failure to thrive.

In each of the eight children and infants diagnosed after 1 mo of age, growth was impaired (mean height,  $-2.6 \pm 1.8$  SD). In the two patients who were not stunted and who were documented to be nonacidotic at 2 mo and 6 mo of age (IV-13 and III-1), growth velocity at time of diagnosis was abnormally reduced to 0.50 and 0.38, respectively, of the mean values predicted for age and sex, and height percentiles were less than half those obtaining at an earlier age: IV-13: 14th at 10 mo, 97.8th at 1 mo; III-1: 16th at 2 yr, 51st at 17 mo. In IV-13, the only patient in whom the possibility was investigated, an impaired renal acidification response to  $\text{NH}_4\text{Cl}$  loading was demonstrated at 2 wk of age (Table 1). In the seven infants, including those who received alkali therapy in the neonatal period and in whom growth velocity had become subnormal (IV-15, age 10 mo, 0.64 of the predicted mean; ID-4, age 3 mo, 0.43) (Fig. 2 B), the mean linear growth velocity was  $0.51 \pm 0.17$  of the predicted mean at the time corrective alkali therapy was started.

In the three patients in whom alkali therapy was not initiated until childhood (IV-8, IV-10, and III-1 [Fig. 4]) and in two patients treated inadequately during childhood (ID-1 at age 5.5 yr and ID-4 at age 2.75 yr [Fig. 3]), growth velocity was  $0.61 \pm 0.18$  of the predicted mean in the period immediately before initiating corrective alkali therapy in childhood.

### *Growth after corrective alkali therapy (Figs. 1–4)*

#### GROUP

*Standard reference population analysis (Fig. 1 A and B).* The mean height of the 10 patients after sustained alkali therapy increased from the 1.4th to 37th percentile. The difference in the percentiles of the mean heights of the 10 patients before and after therapy was significant ( $0.02 < P < 0.01$ ) (paired Student's *t* test). The mean height of the 10 patients after therapy was not significantly different from that of a normal population. The heights of the 10 patients after therapy were distributed from the 1st to the 99th percentile. The heights of four patients were in the 50th percentile or greater; the mean and median heights were almost the same at the 37th and 33rd percentiles, respectively. After alkali therapy, the height percentiles of the 10 patients were distributed normally when tested by either the Rank Normal Deviate Test (56, 57) (Fig. 1 B) or by the W. Statistic of Shapiro and Wilk (58). The percentile for mean height of the unaffected parents (of the six patients with familial RTA) was 4.6 ( $\pm 6.6$ ), significantly smaller than the mean of a normal population. The mean height of all 10 pairs of parents

was in the 28.5th percentile ( $\pm 28$ ), significantly smaller than mean for the parent pairs reported by Tanner ( $0.02 < P < 0.05$ ).

*Tanner analysis.* After therapy, the mean height of the eight patients whose ages permitted analysis by the Tanner technique was in the 69th percentile  $\pm 7.7$ . The ages of only two children (III-1 and IV-10) permitted evaluation of growth by the Tanner technique both before and after therapy; the mean height of these was  $-3.35$  SD before therapy and in the 53rd percentile after therapy.

To evaluate whether parental height significantly affected the height achieved by the patients, the height percentiles attained with therapy by each patient were compared, as analyzed by standard versus Tanner analysis; mean parental height significantly influenced the post-treatment height achieved by the patients ( $P = 0.02$ , Student's paired *t* test).

#### INDIVIDUALS

In each of the 10 infants and children with classic RTA in whom corrective alkali therapy was initiated at ages ranging from 10 days to 9.5 yr and maintained 1–10 yr, normal stature was achieved and maintained (Figs. 1, 2 A, 3 A, and 4 A). Almost immediately after alkali therapy was initiated, growth occurred at strikingly increased, supernormal rates (Figs. 2 B, 3 B, and 4 B).

#### INFANTS

The two infants treated in the neonatal period, IV-15 and ID-4, achieved statures of 57th and 16th percentile, respectively (Fig. 1 B). The percentile of IV-15 was greater than that of her nonaffected parent (14th percentile); that of ID-4 was somewhat less than the 35th percentile predicted on the basis of midparental stature. When corrective alkali therapy was first administered, the two infants grew at rates greater than the mean predicted for their age (IV-15, 1.12; ID-4, 1.50) (Fig. 2 B). The subsequent reduced growth rates of IV-15 and ID-4 were associated with sporadic parental noncompliance in administering alkali therapy (Fig. 2 B). When corrective alkali therapy was reinstated at ages 10 and 13 mo, respectively, growth velocity increased immediately from subnormal to supernormal values (IV-15, twofold; ID-4, 2.8-fold) (Fig. 2 B).

Four of the five infants in whom corrective alkali therapy was first administered after 1 mo of age were stunted at the time of diagnosis. All five infants were of normal stature within 4 mo of initiating alkali therapy, including ID-3, whose stature at age 4.5 mo was 5.5 SD below the predicted mean (Fig. 2 A). The three patients with idiopathic RTA achieved body stature between the 50th and 87th percentiles of that predicted from

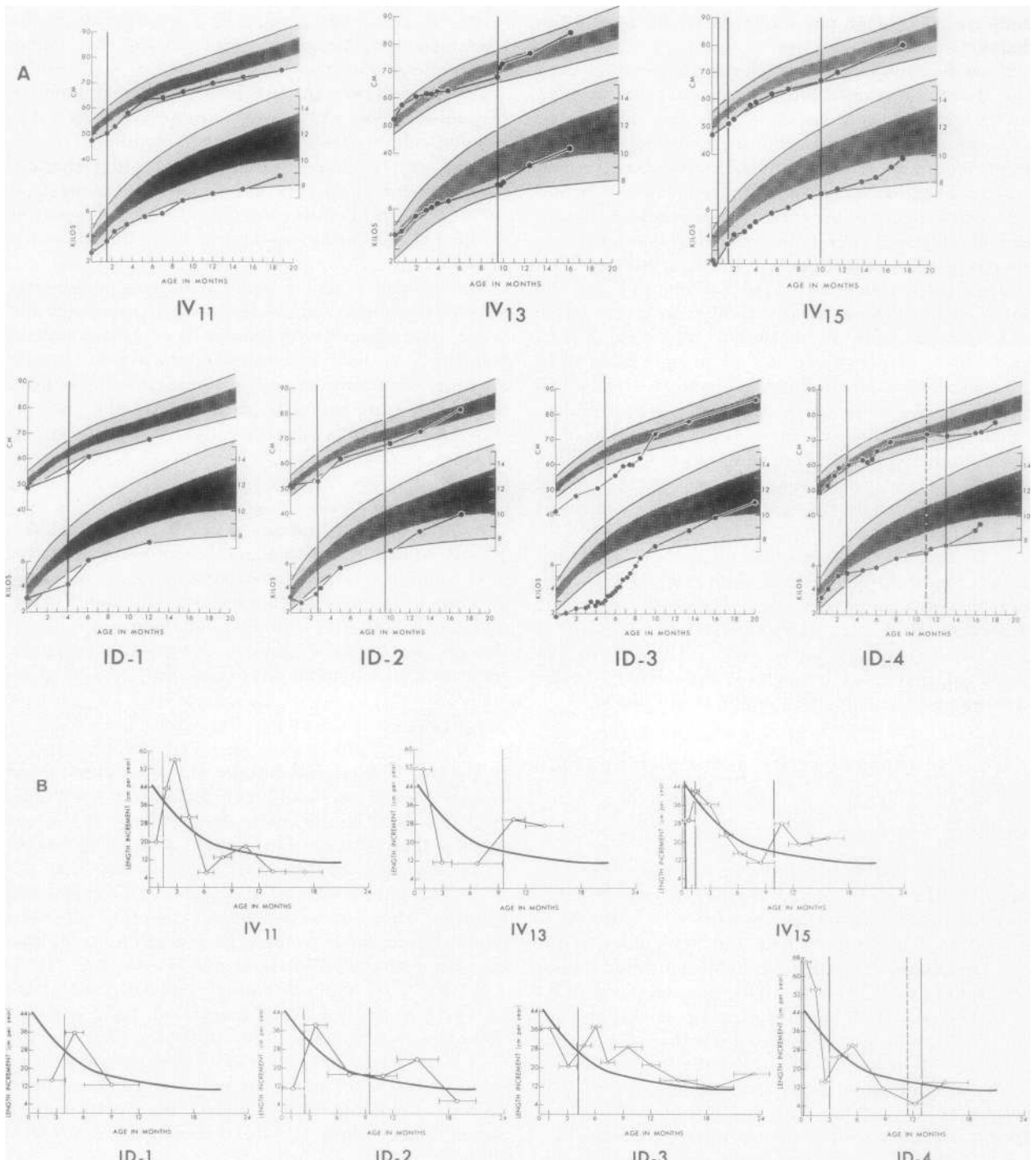

**FIGURE 2** Growth in patients with classic RTA treated in infancy. Vertical lines indicate times at which alkali therapy was initiated or increased after acidosis reoccurred. Interrupted vertical line (ID-4) indicates recommended increase in therapy without parental compliance. (A) Stature: The limits of the shaded and unshaded, enclosed areas indicate  $\pm 1$  and  $\pm 2.5$  SD, respectively, of the mean stature for normal female infants 0–18 mo of age. “Grid” is the Columbia University adaptation (S. Kaplan and M. Grumbach) from data of R. B. Reed and H. C. Stuart (1959. *Pediatrics*. 24: 904). (B) Rate of length growth: Curve indicates the mean value derived from data from normal female infants (26). The circle indicates the midpoint of an observation period; the crossbars, the limits of the period.

midparental height for normal children (54), indicating that the stature of each patient is as large or larger than that which might be predicted for normal children with the same-sized parents. The percentiles of the present stature of the two patients with familial RTA (first treated as infants after 1 mo of age) relative to that of their nonaffected parent are 99:27 for IV-13 and 2: < 1 (-3.72 SD) for IV-11.

For all seven infants, the rate of linear growth immediately after initiation of therapy was  $1.62 \pm 0.18$  that of the mean predicted for sex and age (28) (Fig. 2 B). This rate of growth, compared with that obtaining immediately before alkali therapy was initiated,  $0.51 \pm 0.17$ , constitutes a  $3.24 \pm 0.94$ -fold increase.

#### CHILDREN

In patients IV-10 and III-1, a striking increase in growth rate occurred when alkali therapy was administered at ages 5 and 2 yr, respectively (Fig. 4 B). Normal stature was achieved by IV-10 in 3 yr, height increasing to the 31st percentile from a value 3 SD below the predicted mean (Fig. 4 A). In III-1, height percentile increased from the 16th to the 50th in 2 yr. In IV-8, in whom corrective alkali therapy was not initiated until the age of 9.5 yr, normal stature was achieved 1.5 yr thereafter. IV-8, whose height has been in the 1st percentile for the past 2 yr, can be considered to be of larger stature than his nonaffected father, whose height is -3.72 SD below the mean of adult males. The mean velocity of growth immediately after the initiation of adequate alkali therapy for IV-10, III-1, and IV-8 (Fig. 4 B), and for two patients diagnosed in infancy but inadequately treated during childhood, ID-1 and ID-4 (Fig. 3 B), increased to  $1.50 \pm 0.29$  that of the predicted mean velocity. This velocity, compared with that obtaining before corrective alkali therapy was administered, constituted a  $2.31 \pm 0.94$ -fold increase.

The course of ID-1 is special: In both infancy and childhood, stature became normal after stunting when correction of acidosis was sustained with alkali therapy (Figs. 1 C, 2 A, and 3 A). From the time stunting recurred shortly after infancy until the discovery was made 4.5 yr later that the alkali preparation dispensed as an outpatient was 0.1 the potency prescribed, this patient was repeatedly found to have metabolic acidosis (plasma bicarbonate 14–16 meq/liter). With reinstatement of continuously corrective alkali therapy at age 5.5 yr, growth velocity increased immediately to sustained, supernormal values (Fig. 3 B), and normal height was achieved within 3 yr (Fig. 3 A).

#### *Other possible determinants of growth before and after therapy*

*Duration of acidosis (Fig. 1 C).* In the group of six patients first treated with alkali before 6 mo of age and

in the group of five patients first treated after 6 mo (including ID-1 who received only one-tenth of the prescribed dose of alkali as an out-patient until age 5½ yr), the height (SD) attained before therapy correlated significantly (inversely) with the maximal possible duration of prior acidosis.

After alkali therapy, the height percentiles attained correlated significantly (inversely) with the maximal possible duration of prior acidosis only in the group of patients in whom alkali therapy was initiated after 6 mo of age. In this group, two patients who were the offspring of the same set of parents attained greatly differing height percentiles after alkali therapy: IV-13, in whom alkali therapy was started at age 10 mo, attained the 99th percentile (Tanner); her brother, IV-10, in whom alkali therapy was not started until age 5 yr, attained the 38th percentile.

*Inheritance of the RTA defect.* Before alkali therapy, the mean height of the six patients with familial classic RTA was  $-1.94 (\pm 0.92)$  SD, relative to the standard reference population; that of the four patients with the idiopathic defect,  $-2.97 (\pm 2.07)$  SD. The two means are not significantly different.

After alkali therapy, the mean height attained by the six patients with familial RTA was in the 40th ( $\pm 37.2$ ) percentile, relative to the standard reference population; by the four patients with idiopathic RTA, in the 32.5th ( $\pm 31.1$ ) percentile. When analyzed by the Tanner technique, the mean height attained by the five patients with familial RTA was in the 68th ( $\pm 24.9$ ) percentile; by the three patients with idiopathic RTA in the 70th ( $\pm 20$ ) percentile. Whether analyzed by the standard or Tanner techniques, the mean height attained after alkali therapy by the patients with the familial defect was not significantly different statistically from that of the patients with idiopathic RTA.

*Severity of acidosis.* At the time alkali therapy was initiated, the patients' height percentiles did not correlate with the severity of their acidosis, as judged by the venous CO<sub>2</sub> content.

#### *Correction of acidosis, alkali requirement (Table II)*

In the 10 individuals of the present study, the greatest dosage of alkali therapy required to sustain correction of acidosis ranged from 4.8 to 14.1 meq/kg per day. In all patients except IV-8, correction of acidosis required alkali therapy in an amount of at least 6 meq/kg per day during some period. In all children who were stunted, with the exception of IV-8, alkali therapy of at least this dosage was required before normal growth was achieved. In six of the patients, the corrective dosage of alkali therapy was less than 4 meq/kg per day in the initial observation period. In all but one child (ID-2), the corrective dosage of alkali therapy in the second

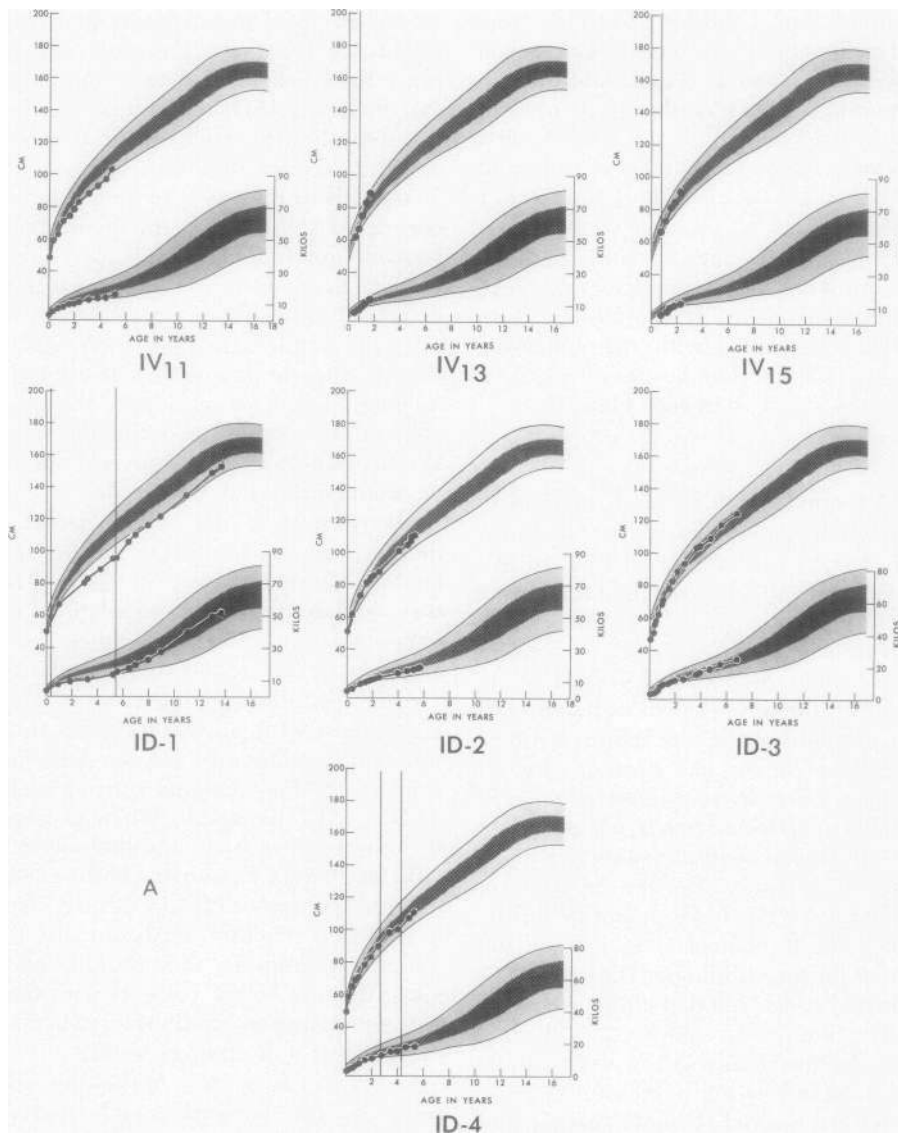

**FIGURE 3** Growth in patients with classic RTA first treated in childhood. Vertical lines indicate times at which alkali therapy was initiated or increased after acidosis reoccurred. Interrupted vertical line (IV-8) indicates initiation of alkali therapy inadequate to correct acidosis. (A) Stature: The limits of the shaded and unshaded, enclosed areas indicate  $\pm 1$  and  $\pm 2.5$  SD, respectively, of

observation period was greater than that in the first; in six patients, the dosage in the second period was approximately twice that of the first. Subtle symptomatology usually accompanied partially corrected acidosis, whatever the dosage of alkali therapy; the children were usually pallid, they fatigued easily, and they were sometimes listless and anorexic.

Plasma bicarbonate concentrations were 1–3 meq/liter greater in the afternoon than in the morning, before the first dose of alkali therapy; in no case was frank alkalosis observed in the afternoon or evening. In no

case was urinary excretion of bicarbonate substantially greater in the afternoon or evening than in the morning.

#### *Bicarbonate excretion after prolonged alkali therapy (Table III)*

In each of the eight rapidly growing patients in whom correction of acidosis had been documented to be sustained for 1–6 mo on a fixed absolute amount of alkali, the corrective amount of alkali therapy ranged from 4.4 to 13.6 meq/kg per day. In these patients,

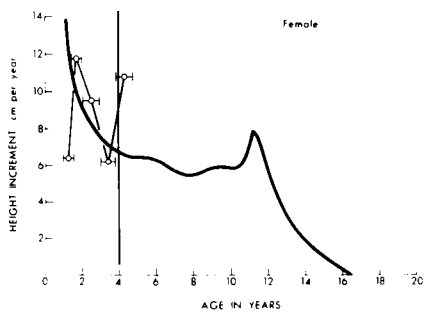

IV-11

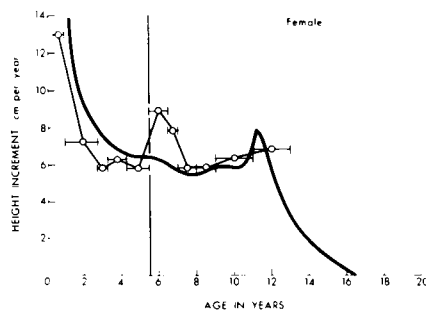

ID-1

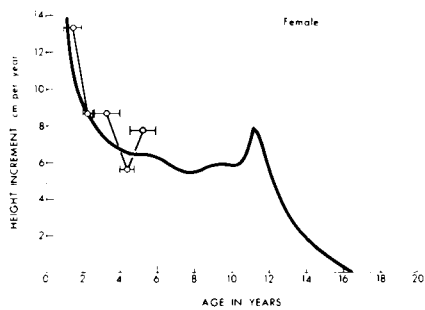

ID-2

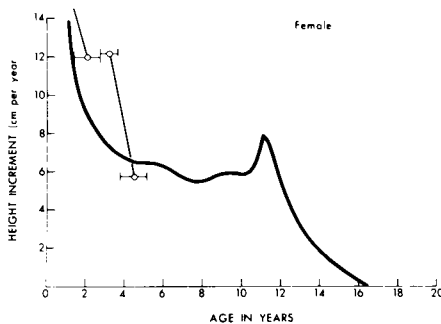

ID-3

B

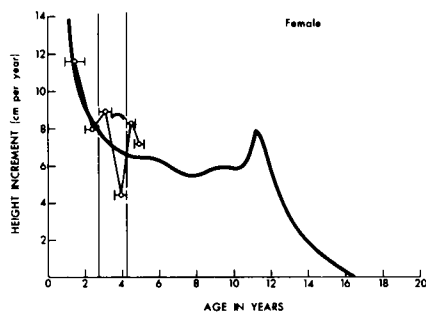

ID-4

the mean stature for normal children. "Grids" are those adapted by S. Kaplan and M. Grumbach from data of R. B. Reed and H. C. Stuart (1959. *Pediatrics*. 24: 904). (B) Rate of height growth: Curve indicates the mean value derived by Tanner et al. (54) from data from normal children. The circle indicates the midpoint of an observation period; the crossbars, the limits of the period.

values of mean urinary excretion of net base ranged from 3.1 to 7.5 meq/kg per day; thus, in each, renal bicarbonate wasting was present. In ID-3, in whom acidosis had not been corrected despite prolonged administration of alkali in a dose of 4.8 meq/kg per day, correction of acidosis with alkali therapy in the amount of 6.9 meq/kg per day was attended by a mean urinary net base excretion of 4.3 meq/kg per day. In the four patients in whom the measurements were made (IV-13, IV-11, ID-3, and IV-8), the values of blood and plasma volumes, plasma renin activity, and 24-h excretion of

urinary aldosterone were not abnormal during sustained correction of acidosis. Each patient was growing at a supernormal velocity (Figs. 2 B, 3 B, and 4 B) except IV-8, in whom height velocity was increasing (coincident with an increase in alkali therapy).

In each of the four patients in whom alkali therapy was abruptly diminished (to 8.7, 3.1, 3.0, and 2.0 meq/kg per day), acidosis promptly occurred and persisted throughout the period studied, and in three of the four patients, the urinary excretion of calcium increased significantly to values > 2 mg/kg per day. In three

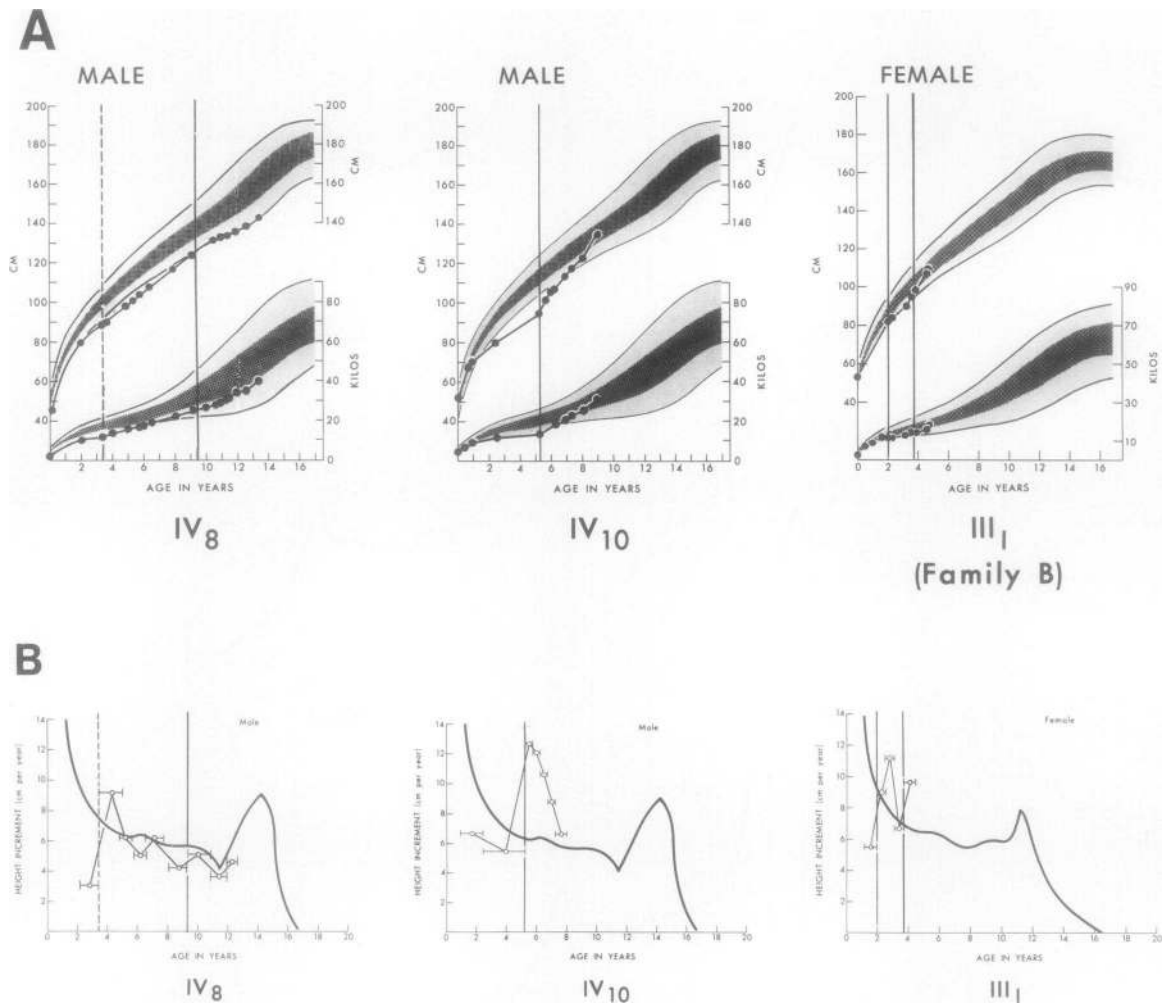

**FIGURE 4** Growth in patients with classic RTA first treated in childhood. Vertical lines indicate times at which alkali therapy was initiated or increased after acidosis reoccurred. Interrupted vertical line (IV-8) indicates initiation of alkali therapy inadequate to correct acidosis. (A) Stature: The limits of the shaded and unshaded, enclosed areas indicate  $\pm 1$  and  $\pm 2.5$  SD, respectively, of the mean stature for normal children. "Grids" are those adapted from data of R. B. Reed and H. C. Stuart (1959. *Pediatrics*. 24: 904). (B) Rate of height growth: Curve indicates the mean value derived by Tanner (54) from data from normal children. The circle indicates the midpoint of an observation period; the crossbars, the limits of the period. "Grids" for IV-8 and IV-10, from male populations; for III-1, from female.

patients, the urinary excretion of calcium was normal before alkali therapy was diminished. In the two patients whose dosage of alkali therapy was reduced to 3 meq/kg per day, urinary excretion of calcium became greater than 5 mg/kg per day, a value more than twice that of the upper limit recommended for adequate therapy (11, 37). The reduction in dosage of alkali therapy was in each instance accomplished entirely by, or largely by, a reduction in dose of sodium bicarbonate, and in each instance the reduced dosage schedule was accompanied by significant reduction of urinary excretion

of sodium. Chloride excretion remained approximately 3 meq/kg per day in each patient, decreasing slightly in ID-4 only. Body weight and creatinine clearances did not change. There was no change in caloric intakes, as judged by a research dietician's count of calories in the food ingested.

In the one study (ID-3) in which alkali dosage was abruptly increased, the plasma bicarbonate concentration increased from subnormal values to values within the normal range. In this study, in which alkali therapy consisted only of potassium bicarbonate, urinary excretion

tion of calcium, sodium, and chloride decreased significantly, although alkali dosage was increased only from 4.8 to 6.9 meq/kg per day.

#### *Acidosis during prolonged alkali therapy of 4.3–10.3 meq/kg per day (Table IV)*

Acidosis occurred as an outpatient in each of six rapidly growing children in whom the absolute dose of alkali prescribed as an outpatient had remained unchanged for 3–10 months. When initiated, the dose ranged from 4.4 to 12.0 meq/kg per day and was documented to be sufficient to maintain correction of acidosis. After periods of 3–10 mo, when acidosis had occurred, doses ranged from 4.3 to 10.3 meq/kg per day. In six patients studied under metabolic conditions in nine studies of 3–10 days' duration, the values for serum venous CO<sub>2</sub> content ranged from 17.0 to 23.3 meq/liter and arterial plasma HCO<sub>3</sub><sup>-</sup> concentration from 17.0 to 21.9 meq/liter with continued administration of alkali at a dose of 4.3 to 10.3 meq/kg per day. Net base excretion ranged from 2.1 to 6.9 meq/kg per day with the exception of one study. (In this study, [IV-13, age 1 yr, ½ mo], urinary net base excretion was 0.4 meq/kg per day, and in distinction from all other studies, including the other two in IV-13, the patient had received alkali therapy for less than 1 yr [from only 10 to 12½ mo of age] and the intake of NaCl was low—less than 2 meq/kg per day. In five of the six patients, net base excretion exceeded 3.4 meq/kg per day. Blood and plasma volumes, plasma renin activity, and urinary aldosterone excretion were within normal limits. There was no correlation between net base and urinary chloride excretion.

## DISCUSSION

The results of the present study indicate that in infants and children with classic RTA, impaired growth can be prevented or corrected when alkali therapy is continuously provided in amounts that sustain correction of acidosis. In each of 10 infants and children with persisting classic RTA, continued provision of corrective alkali therapy was attended by achievement of persisting normal stature.

Before alkali therapy was initiated, the mean height of the 10 patients was in the 1.4th percentile. After sustained correction of acidosis with alkali therapy, the mean height was in the 37th percentile. After therapy, the heights of all the affected children were within the normal range and were distributed normally between the 1st through 99th percentiles when compared with a sex- and age-matched normal population; the heights of 4 of the 10 children were in the 50th percentile or greater. The mean height of the 10 children was not significantly different from the mean of the normal

population, in contrast to the value of the mean height of the 10 sets of parents, which was significantly smaller than that of a normal population ( $0.02 < P < 0.05$ ) (54). In the group of eight patients whose height after therapy could be analyzed by the Tanner technique, the mean height was in the 69th percentile, taller than the mean predictable for age- and sex-matched normals. The Tanner technique has not been used in previously reported studies of growth in children with classic RTA.

Six of the patients, including four infants, were frankly stunted when alkali therapy was initiated. Prolonged acidosis preceded the occurrence of stunted growth in each of the four patients in whom the possibility could be investigated. Of the four patients who were not stunted when alkali therapy was initiated, two were two young (<2 wk of age) for stunting to have occurred. The two others were members of affected kindreds and had been observed initially to be nonacidotic; in both of these, however, height percentiles had decreased after the initial observations. After institution of alkali therapy, all 10 patients grew at velocities substantially greater than those predicted for their ages. Each of the eight patients in whom alkali therapy was begun after 1 mo of age grew at velocities greater than those obtaining immediately before alkali therapy was begun. In each of five infants in whom alkali therapy was initiated (at ages ranging from 1 mo to 1 yr), including one infant who was not frankly stunted, height velocity increased two- to fourfold within 2 mo of initiating therapy. All five infants attained normal stature within 6 mo of initiating therapy, including one whose height was 5.5 SD below the predicted mean when alkali therapy was begun at age 4.5 mo. In each of three older stunted children, in whom corrective alkali therapy was initiated at ages 3.5, 5, and 5.5 yr, height velocity increased two- to threefold within 1 yr of initiating adequate alkali therapy and normal height stature was attained within 3 yr.

A priori it could not have been predicted that in the present study each of the 10 children with classic RTA would attain normal height percentiles with alkali therapy. Given just one other published systematic study of growth in children with classic RTA, one might have inferred that growth was limited by pathogenetic factors other than those responsive to alkali therapy (30). Since classic RTA can be the expression of a number of disease processes (18), it could have been formulated that in those affected children who remained stunted after alkali therapy, the underlying disease process, not acidosis, was limiting with respect to growth. Yet in the present study it is clear that metabolic acidosis (with its metabolic consequences) was the overriding determinant of impaired growth, irrespective of whether the disorder of renal acidification was idiopathic or a familial, genetically transmitted trait. Thus, in stunted infants or prepubertal children

with metabolic acidosis caused by RTA, physiological characterization of the disorder as classic (Type I) RTA has important prognostic power: with sustained correction of acidosis, normal height will be attained. If correcting alkali therapy is initiated before the age of 6 mo, the height attained will be limited only by the inherent and calculable genetic capacity for growth. Initiation of corrective alkali therapy after 6 mo of age may, to some undetermined extent, prevent full realization of the genetic potential for height attainment, but will not prevent attainment of normal height.

In patients with classic RTA of the present study, sustained correction of acidosis required administration of alkali therapy in amounts ranging from 5 to 14 meq/kg per day. This range of alkali dosage is substantially greater than that recently recommended for children with classic RTA, 1 to 3 meq/kg per day (11, 14, 19, 30, 36, 37), but accords with that found necessary by many earlier investigators (2, 38–47). In all but one patient, sustained correction of acidosis required alkali therapy at a dosage of at least 6 meq/kg per day during some period. In the five stunted patients in whom corrective alkali therapy was begun at 5.5 yr of age or younger, at least 6 meq/kg per day was required before normal height was achieved.

The magnitude of urinary bicarbonate wasting, 3.1–7.5 meq/kg per day, was the major determinant of the amount of alkali therapy in each of nine rapidly growing patients, studied when correction of acidosis required large doses of alkali therapy (4.8–13.6 meq/kg per day). In eight of the nine patients, the sum of the values of measured urinary net base excretion and an assumed endogenous acid production of 3 meq/kg per day equaled or exceeded the value of daily alkali intake; in the ninth patient, a rapidly growing 17½-mo-old girl, the magnitude of urinary net base excretion (7.5 meq/kg per day) plus an endogenous production of nonvolatile acid of 3 meq/kg per day accounted for 77% of the alkali requirement (13.6 meq/kg per day). In this patient, gut wasting of bicarbonate and (or) an abnormally increased production of endogenous acid may have accounted for the remaining 3 meq/kg per day.

It might be argued that in these patients the large amounts of alkali therapy administered were more than those necessary to sustain correction of acidosis, and that excessive alkali therapy caused, or contributed to, the magnitude of bicarbonate wasting by overexpanding extracellular fluid volume (64, 65). But several findings do not accord with this formulation. During the period these patients received large doses of alkali therapy, the measured values of blood and plasma volume were not increased and the values for 24-h excretion of aldosterone and plasma renin activity were not decreased. Furthermore, in six patients of the present study, mild acidosis occurred and persisted despite continued administration of alkali therapy in

amounts documented earlier to correct acidosis, amounts ranging from 4.2 to 10.3 meq/kg per day. And in each of these six patients, frank bicarbonate wasting occurred despite the acidosis and normal values of blood and plasma volume and normal or even elevated values of 24-h aldosterone excretion and plasma renin activity (Table IV). During acidosis, in each child the sum of the net base excretion and an assumed endogenous production of acid of 2–3 meq/kg per day closely approximated the amount of alkali administered. These findings provide strong evidence that in growing infants and children with classic RTA, large amounts of alkali therapy (>3 meq/kg per day) are required to sustain correction of acidosis because of the magnitude of renal bicarbonate wasting that predictably occurs in these patients.

The previously recommended dosage of alkali therapy of 1–3 meq/kg per day for infants and children with classic RTA has often been attended by a modest increase in stature but apparently never by the occurrence of normal stature after previous stunting (23–26, 30, 32). Since this dosage of alkali has not been documented to sustain correction of acidosis in stunted infants and children with classic RTA, and since the 10 patients of the present study required alkali therapy in amounts ranging from 5 to 14 meq/kg per day to sustain correction of acidosis before normal stature was achieved, our findings suggest that an optimal growth response in patients with classic RTA may require alkali therapy in amounts sufficient to maintain plasma bicarbonate concentration within the normal range.

The possible causal relationship between acidosis and growth failure has been considered by a number of investigators (32, 35, 66–68). In both children and adult patients with classic RTA, it has been repeatedly demonstrated that intestinal absorption of calcium is decreased during acidosis and increased with alkali therapy (1, 21, 25, 34, 69). In children with classic RTA, impaired growth is frequently associated with frank rickets or osteopenia (1, 21, 23–25, 27, 70). The bone disease of both children and adult patients with untreated classic RTA is predictably healed with alkali therapy alone (7, 23, 27), and it would appear that the healing process can begin almost immediately after alkali therapy is initiated (70). 1,25-(OH)<sub>2</sub> vitamin D<sub>3</sub> (1,25-(OH)<sub>2</sub>D<sub>3</sub>) is the most biologically active metabolite of vitamin D known with respect to gut absorption of calcium, bone reabsorption, and the healing of rickets, and is synthesized uniquely in the renal cortex from 25(OH)D<sub>3</sub> (71, 72). Although ammonium chloride-induced acidosis in normal adult subjects was not attended by a demonstrable reduction either in the intestinal absorption of calcium or in the conversion of 25(OH)D<sub>3</sub> to 1,25-(OH)<sub>2</sub>D<sub>3</sub> (73), evidence of a reduction in this conversion has been reported in vitamin D-deficient weanling rats (74) and chicks (75) given



ammonium chloride to induce metabolic acidosis. Since hyperchloremic metabolic acidosis (and impaired growth) occurs spontaneously in vitamin D-deficient chicks (76), the metabolic and physiologic effects of vitamin D deficiency and metabolic acidosis may be mutually compounding (76). Stickler and Bergen have suggested that an abnormality in the metabolism of vitamin D underlies the deficient growth of children with renal insufficiency (33). It is clear that in patients with severely reduced glomerular filtration rate (77, 78) conversion of 25(OH)D<sub>3</sub> to 1,25-(OH)<sub>2</sub>D<sub>3</sub> is

greatly reduced. In the vitamin D-deficient rat, maleic acid induces both a complex dysfunction of the renal tubule like that of Fanconi's syndrome and a substantial reduction in the conversion of tritiated 25(OH)D<sub>3</sub> to 1,25-(OH)<sub>2</sub>D<sub>3</sub>, without a significant reduction in glomerular filtration rate (79). In infants and children with untreated classic RTA, the pathogenesis of growth impairment might require an acidosis-dependent impairment in the renal conversion of 25(OH)D<sub>3</sub> to 1,25-(OH)<sub>2</sub>D<sub>3</sub>, and perhaps to other biologically active metabolites of 25(OH)D<sub>3</sub> as well.

#### APPENDIX

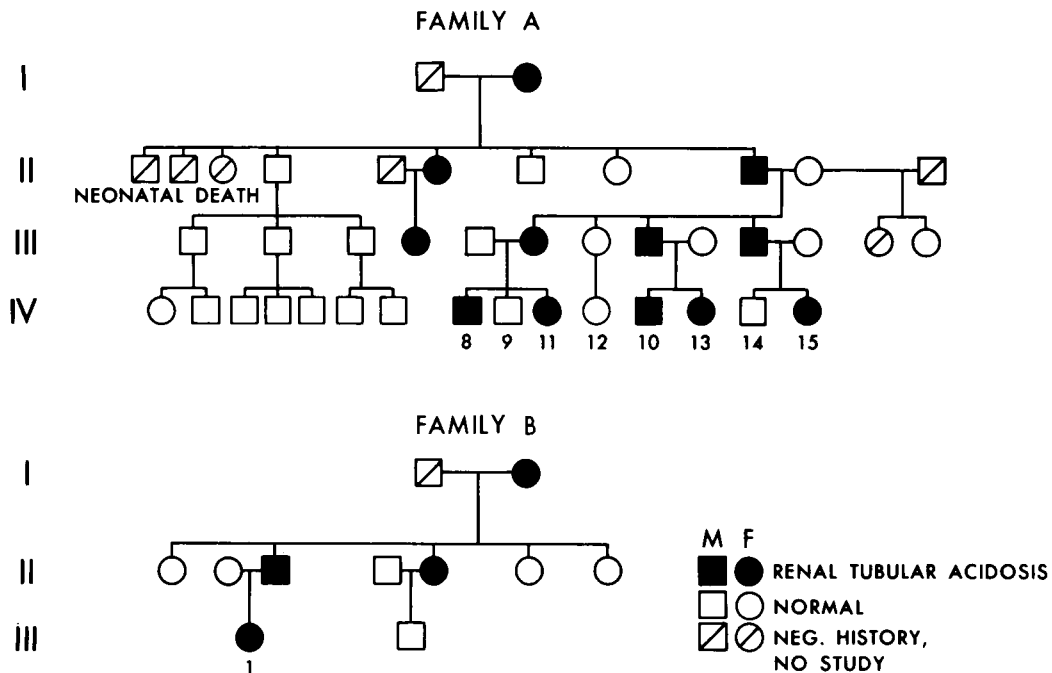

The occurrence of classic renal tubular acidosis in two families. When the pedigree of family A was last published (49), members IV-11 to IV-15 had not been born. The pedigree of family B has not been previously published. Initials and clinical data for patients in generation IV of family A and generation III of family B are in Table I.

#### ACKNOWLEDGMENTS

We gratefully acknowledge the technical assistance of Bernadine Serena, Kathleen Nigon, Joanne Schweiger, Ann Ince, and Kathleen Gully. We thank Dr. Anthony Sebastian for his helpful comments and Drs. Edward G. Biglieri, Director, and Morris Schambelan, Assistant Director, Clinical Research Center, San Francisco General Hospital, for the determinations of urinary aldosterone and plasma renin activity, respectively. We thank Dr. Julien Hoffman of the Cardiovascular Research Institute for his generous and very helpful assistance with statistical evaluations.

This research was supported in part by a program project grant of the National Institutes of Health (AM-16764), and the research was carried out in the Pediatric and General Clinical Research Centers under grant RR-00079.

#### REFERENCES

1. Albright, F., C. H. Burnett, W. Parson, E. C. Reifenstein, and A. Roos 1946. Osteomalacia and late rickets: the various etiologies met in the United States with emphasis on that resulting from a specific form of renal acidosis, the therapeutic indications for each etiological sub-group, and the relationship between osteomalacia and Milkman's syndrome. *Medicine (Baltimore)*. **25**: 399-479.
2. Lightwood, R., W. W. Payne, and J. A. Black. 1953. Infantile renal acidosis. *Pediatrics*. **12**: 628-644.
3. Pines, K. L., and G. H. Mudge. 1951. Renal tubular acidosis with osteomalacia: report of three cases. *Am. J. Med.* **11**: 302-311.
4. Smith, L. H., Jr., and G. E. Schreiner. 1954. Studies on

- renal hyperchloremic acidosis. *J. Lab. Clin. Med.* **43**: 347-358.
5. Reynolds, R. B. 1958. Observations of renal tubular acidosis. *Am. J. Med.* **25**: 503-515.
  6. Wrong, O., and H. E. F. Davies. 1959. The excretion of acid in renal disease. *Q. J. Med.* **28**: 259-313.
  7. Seldin, D. W., and J. D. Wilson. 1972. Renal tubular acidosis. In *The Metabolic Basis of Inherited Disease*, J. B. Stanbury, J. B. Wyngaarden, and D. S. Fredrickson, editors. McGraw-Hill Book Company, New York. 3d edition. 1548-1566.
  8. Morris, R. C., Jr., and H. H. Fudenberg. 1967. Impaired renal acidification in patients with hypergamma-globulinemia. *Medicine (Baltimore)*. **46**: 57-69.
  9. Soriano, J. R., H. Boichis, and C. M. Edelmann, Jr. 1967. Bicarbonate reabsorption and hydrogen ion excretion in children with renal tubular acidosis. *J. Pediatr.* **71**: 802-813.
  10. Morris, R. C., Jr. 1968. An experimental renal acidification defect in patients with hereditary fructose intolerance. II. Its distinction from classic renal tubular acidosis: its resemblance to the renal acidification defect associated with the Fanconi syndrome of children with cystinosis. *J. Clin. Invest.* **47**: 1648-1663.
  11. Soriano, J. R., and C. M. Edelmann, Jr. 1969. Renal tubular acidosis. *Ann. Rev. Med.* **20**: 363-382.
  12. Morris, R. C., Jr. 1969. Renal tubular acidosis: mechanisms, classification and implications. *N. Engl. J. Med.* **281**: 1405-1413.
  13. Sebastian, A., E. McSherry, and R. C. Morris, Jr. 1971. On the mechanisms of renal potassium wasting in renal tubular acidosis associated with the Fanconi syndrome (type 2 RTA). *J. Clin. Invest.* **50**: 231-243.
  14. Edelmann, C. M., Jr., and H. L. Barnett. 1971. Pediatric nephrology. In *Diseases of the Kidney*, M. B. Strauss and L. G. Welt, editors. Little, Brown and Company, Boston. 2d edition. 1392-1395.
  15. McSherry, E., A. Sebastian, and R. C. Morris, Jr. 1972. Renal tubular acidosis (RTA) in infants: the several kinds, including bicarbonate-wasting, classic renal tubular acidosis. *J. Clin. Invest.* **51**: 499-514.
  16. Rodriguez-Soriano, J., A. Vallo, and M. Garcia-Fuentes. 1975. Distal renal tubular acidosis in infancy: a bicarbonate wasting state. *J. Pediatr.* **86**: 524-532.
  17. Leumann, E. P., and B. Skinmann. 1975. Persistent and transient distal renal tubular acidosis with bicarbonate wasting. *Pediatr. Res.* **9**: 767-773.
  18. Morris, R. C., Jr., A. Sebastian, and E. McSherry. 1972. Renal acidosis. *Kidney Int.* **1**: 322-340.
  19. Edelmann, C. M., Jr. 1973. Renal tubular acidosis. In *The Body Fluids in Pediatrics*. R. W. Winters, editor. Little, Brown and Company, Boston. 385-401.
  20. Butler, A. M., J. L. Wilson, and S. Farber. 1936. Dehydration and acidosis with calcification of renal tubules. *J. Pediatr.* **8**: 489-499.
  21. Albright, F., W. V. Consolazio, F. S. Coombs, H. W. Sulkowith, and J. H. Talbott. 1940. Metabolic studies and therapy in a case of nephrocalcinosis with rickets and dwarfism. *Bull. Johns Hopkins Hosp.* **66**: 7-33.
  22. Cooke, R. E., and C. R. Kleeman. 1950. Distal tubular dysfunction with renal calcification. *Yale J. Biol. Med.* **23**: 199-206.
  23. Foss, G. L., C. B. Perry, and F. J. Y. Wood. 1956. Renal tubular acidosis. *Q. J. Med.* **98**: 185-199.
  24. Seedat, Y. K. 1964. Some observations of renal tubular acidosis—a family study. *S. Afr. Med. J.* **38**: 606-610.
  25. Greenberg, A. J., H. McNamara, and W. W. McCrory. 1966. Metabolic balance studies in primary renal tubular acidosis: effects of acidosis on external calcium and phosphorus balances. *J. Pediatr.* **69**: 610-618.
  26. Watson, E. H., and G. H. Lowrey. 1969. Growth and Development of Children. Year Book Medical Publishers, Inc., Chicago. 87-88.
  27. Royer, P. 1968. Chronic tubular disease. In *Nephrology*, Vol. I. J. Hamburger, G. Richet, J. Crosnier, J. L. Funck-Brentano, B. Antoine, H. Ducrot, J. P. Mery, and H. DeMontera. W. B. Saunders Company, Philadelphia. 576-719.
  28. Sobel, E. 1968. Preschool and school age child: growth problems. In *Biological Basis of Pediatric Practice*, Vol. II. McGraw-Hill Book Company, New York. 1568-1569.
  29. Milne, M. D. 1970. Genetic aspects of renal disease. In *Progress in Medical Genetics*, Vol. VII. A. G. Steinberg and A. G. Bearn, editors. Grune & Stratton, Inc., New York. 112-162.
  30. Nash, M. A., A. D. Torrado, I. Greifer, A. Spitzer, and C. M. Edelmann, Jr. 1972. Renal tubular acidosis in infants and children. *J. Pediatr.* **80**: 738-748.
  31. McSherry, E., A. Sebastian, and R. C. Morris, Jr. 1973. Correction of impaired growth in children with classic renal tubular acidosis (cRTA) by sustained correction of acidosis. *Clin. Res.* **21**: 700. (Abstr.)
  32. Palmer, R. H., and D. Cornfeld. 1973. Primary renal tubular acidosis recognized and treated at three days of age. A case report illustrating the value of routine postmortem examination. *Clin. Pediatr.* **12**: 140-144.
  33. Stickler, G. B., and B. J. Bergen. 1973. A review: short stature in renal disease. *Pediatr. Res.* **7**: 978-982.
  34. Goodman, A. D., J. Lemann, Jr., E. J. Lennon, and A. S. Relman. 1965. Production, excretion, and net balance of fixed acid in patients with renal acidosis. *J. Clin. Invest.* **44**: 495-506.
  35. Relman, A. S., E. J. Lennon, and J. Lemann, Jr. 1961. Endogenous production of fixed acid and the measurement of the net balance of acid in normal subjects. *J. Clin. Invest.* **40**: 1621-1630.
  36. Rodriguez-Soriano, J., H. Biochis, H. Stark, and C. M. Edelmann, Jr. 1967. Proximal renal tubular acidosis. A defect in bicarbonate reabsorption with normal urinary acidification. *Pediatr. Res.* **1**: 81-98.
  37. Rodriguez-Soriano, J. 1971. The renal regulation of acid-base balance and the disturbances noted in renal tubular acidosis. *Pediatr. Clin. North Am.* **18**: 529-545.
  38. Latner, A. L., and E. D. Burnard. 1950. Idiopathic hyperchloraemic renal acidosis of infants (nephrocalcinosis infantum). Observations on the site and nature of the lesion. *Q. J. Med.* **13**: 940-956.
  39. Hartmann, A. F. 1939. Clinical studies in acidosis and alkalosis; use and abuse of alkali in states of bicarbonate deficiency due to renal acidosis and sulfanilamide alkalosis. *Ann. Intern. Med.* **13**: 940-956.
  40. Peterman, M. G. 1945. Chronic pyelonephritis with renal acidosis. *Am. J. Dis. Child.* **69**: 292-294.
  41. Powell, B. W. 1949. Nephrocalcinosis in infancy. *Proc. R. Soc. Med.* **42**: 559.
  42. Stapleton, T. 1949. Idiopathic renal acidosis in an infant with excessive loss of bicarbonate in the urine. *Lancet.* **1**: 683-685.
  43. Kelsey, W. M., J. B. Reinhart, and B. S. Fishel. 1950. Chronic acidosis of renal origin in infancy. *Pediatrics.* **5**: 689-694.
  44. Hutchinson, J. H., and A. M. MacDonald. 1951. Chronic acidosis in infants due to renal tubular deficiency: its association with metastatic calcification. *Acta Paediatr. Scand.* **40**: 371-400.

45. Doxaidis, S. A. 1952. Idiopathic renal acidosis in infancy. *Arch. Dis. Child.* **27**: 409–427.
46. Rendle-Short, J. 1953. Idiopathic renal acidosis in twins. *Arch. Dis. Child.* **28**: 55–56.
47. Carre, I. J., B. S. B. Wood, and W. C. Smallwood. 1954. Idiopathic renal acidosis in infancy. *Arch. Dis. Child.* **29**: 326–333.
48. Randall, R. E., Jr., and W. H. Targgart. 1961. Familial renal tubular acidosis. *Ann. Intern. Med.* **54**: 1108–1116.
49. Randall, R. E., Jr. 1967. Familial renal tubular acidosis revisited. *Ann. Intern. Med.* **49**: 1024–1025.
50. Morris, R. C., Jr., C. F. Piel, and E. Audioun. 1965. Renal tubular acidosis. Effects of sodium phosphate and sulfate on renal acidification in two patients with renal tubular acidosis. *Pediatrics.* **36**: 899–904.
51. Edelmann, C. M., Jr., J. Rodriguez-Soriano, H. Biochis, A. B. Gruskin, and M. I. Acosta. 1967. Renal bicarbonate reabsorption and hydrogen ion excretion in normal infants. *J. Clin. Invest.* **46**: 1309–1317.
52. Edelmann C. M., Jr., H. Boichis, J. Rodriguez-Soriano, and H. Stark. 1967. The renal response of children to acute ammonium chloride acidosis. *Pediatr. Res.* **1**: 452–460.
53. Albert, M. S., and R. W. Winters. 1966. Acid-base equilibrium of blood in normal infants. *Pediatrics.* **37**: 728–732.
54. Tanner, J. M., H. Goldstein, and R. H. Whitehouse. 1970. Standards for children's height from ages 2–9 years allowing for heights of parents. *Arch. Dis. Child.* **45**: 755–762.
55. Tanner, J. M. 1962. Growth at Adolescence. Blackwell Scientific Publications, Ltd., Oxford. 1–10.
56. Sokol, R. R., and F. J. Rohlf. 1969. Biometry. W. H. Freeman and Company, San Francisco.
57. Sokol, R. R., and F. J. Rohlf. 1969. Statistical Tables. W. H. Freeman and Company, San Francisco.
58. Shapiro, S. S., and M. B. Wilk. 1965. An analysis of variance test for normality (complete samples). *Biometrika.* **52**: 591–611.
59. Royer, P., H. Lestradet, R. Nordmann, H. Mathieu, and J. Rodriguez-Soriano. 1962. Études sur quatre cas d'acidose tubulaire chronique idiopathique avec hypocitraturie. *Ann Pédiatr. (Paris).* **38**: 808–829.
60. Gibson, J. H., II, and W. A. Evans, Jr. 1937. Clinical studies on blood volume. II. The relation of plasma and total blood volume to venous pressure, blood velocity rate, physical measurements, age and sex in ninety normal humans. *J. Clin. Invest.* **16**: 317–328.
61. New, M. I., B. Miller, and R. E. Peterson. 1966. Aldosterone excretion in normal children and in children with adrenal hyperplasia. *J. Clin. Invest.* **45**: 412–442.
62. Stark, P., R. Beckerhoff, E. P. Leumann, W. Vetter, and W. Siegenthaler. 1975. Control of plasma aldosterone in infancy and childhood. *Helv. Paediatr. Acta.* **30**: 349–356.
63. Food and Nutrition Board, National Academy of Sciences National Research Council. Recommended daily dietary allowances. Revised 1973.
64. Kurtzman, N. A. 1970. Regulation of renal bicarbonate reabsorption by extracellular volume. *J. Clin. Invest.* **49**: 586–595.
65. Slatopolsky, E., P. Hoffsten, M. Purkerson, and N. S. Bricker. 1970. On the influence of extracellular fluid volume expansion and of uremia on bicarbonate reabsorption in man. *J. Clin. Invest.* **48**: 988–998.
66. West, C. D., and W. C. Smith. 1956. An attempt to elucidate the cause of growth retardation in renal disease. *Am. J. Dis. Child.* **91**: 460–476.
67. Cooke, R. E., D. G. Boyden, and E. Haller. 1960. The relationship of acidosis and growth retardation in renal disease. *J. Pediatr.* **57**: 326–337.
68. Bergstrom, W. H., A. S. deLeon, and J. J. van Gemund. 1964. Growth aberrations in renal disease. *Pediatr. Clin. North Am.* **11**: 563–575.
69. Bauld, W. S., S. A. MacDonald, and M. C. Hill. 1958. Effect of renal tubular acidosis on calcium excretion. *Br. J. Urol.* **30**: 285–291.
70. Mutalen, C., R. Montoreano, and C. Labarrere. 1976. Early skeletal effect of alkali therapy upon the osteomalacia of renal tubular acidosis. *J. Clin. Endocrinol. Metab.* **42**: 875–881.
71. DeLuca, H. F., and H. K. Schnoes. 1976. Metabolism and mechanisms of action of vitamin D. *Ann. Rev. Biochem.* **45**: 631–666.
72. Norman, H. W., and H. Henry. 1974. 1,25-Dihydroxycholecalciferol—a hormonally active form of vitamin D<sub>3</sub>. *Recent Prog. Horm. Res.* **30**: 431–480.
73. Weber, H. P., R. W. Gray, J. H. Dominguez, and J. Lemann, Jr. 1976. The lack of effect of chronic metabolic acidosis on 25-OH-vitamin D metabolism and serum parathyroid hormone in humans. *J. Clin. Endocrinol. Metab.* **43**: 1047–1055.
74. Lee, S. W., J. E. Russell, and L. V. Avioli. 1977. 25-OHD<sub>3</sub> to 1,25-(OH)<sub>2</sub>D<sub>3</sub>: conversion impaired by systemic acidosis. *Science (Wash. D. C.).* **195**: 994–996.
75. Sauveur, B., M. Garabedian, C. Fellet, P. Mongin, and S. Balsan. 1977. The effect of induced metabolic acidosis on vitamin D<sub>3</sub> metabolism in rachitic chicks. *Calcif. Tissue Res.* **23**: 121–124.
76. Booth, B. E., H. C. Tsai, and R. C. Morris. 1977. Metabolic acidosis in the vitamin D-deficient chick. *Metab. Clin. Exp.* **26**: 1099–1105.
77. Mawer, B. R., C. M. Taylor, J. Backhouse, and G. A. Lumb. 1973. Failure of formation of 1,25-dihydroxycholecalciferol in chronic renal insufficiency. *Lancet.* **1**: 626–628.
78. Piel, C. F., B. S. Roof, and L. V. Avioli. 1973. Metabolism of tritiated 25-hydroxycholecalciferol in chronically uremic children before and after successful renal homotransplantation. *J. Clin. Endocrinol. Metab.* **37**: 944–948.
79. Brewer, E. D., H. C. Tsai, K. S. Szeto, and R. C. Morris, Jr. 1977. Maleic acid-induced impaired conversion of 25 (OH)D<sub>3</sub> to 1,25(OH)<sub>2</sub>D<sub>3</sub>: implications for Fanconi syndrome. *Kidney Int.* **12**: 244–252.