

## Audio Denoising Based on Short Time Fourier Transform

J.S. Ashwin<sup>1</sup>, N. Manoharan<sup>2</sup>

<sup>1</sup>Research Scholar, Department of Electrical and Electronics Engineering (Marine), AMET University, Chennai

<sup>2</sup>Rector, AMET University, Chennai

---

### Article Info

#### Article history:

Received Jul 8, 2017

Revised Nov 20, 2017

Accepted Dec 11, 2017

---

#### Keywords:

Audio de-noising

AWGN

PSNR

SNR

STFT

---

### ABSTRACT

This paper presents a novel audio de-noising scheme in a given speech signal. The recovery of original from the communication channel without any noise is a difficult task. Many de-noising techniques have been proposed for the removal of noises from a digital signal. In this paper, an audio de-noising technique based on Short Time Fourier Transform (STFT) is implemented. The proposed architecture uses a novel approach to estimate environmental noise from speech adaptively. Here original speech signals are given as input signal. Using AWGN, noises are added to the signal. Then noised signals are de-noised using STFT techniques. Finally Signal to Noise Ratio (SNR), Peak Signal to Noise Ratio (PSNR) values for noised and de-noised signals are obtained.

Copyright © 2018 Institute of Advanced Engineering and Science.  
All rights reserved.

---

### Corresponding Author:

J.S. Ashwin,

Research Scholar, Department of Electrical and Electronics Engineering (Marine),  
AMET University, Chennai

---

## 1. INTRODUCTION

Generally in the signal processing applications the noise distribution seems to be a major problem. The nonessential signals are superimposed over an undisturbed signal. When the regularity of the noise reduces then the denoising methods get more difficult.

## 2. BACKGROUND

Speech de-reverberation and de-noising using learning spectral mapping is presented in [1]. Spectral mapping is learned directly using the training of deep neural networks from the magnitude spectrogram of contaminated speech to that of hygienic speech. This approach considerably attenuates the twist caused by reverberation, as well as background noise.

Spectral scarcity based multichannel audio de-noising formulation is described in [2]. Two stage methods are used for this evaluation problem. It does not need any details about noise. There are two stages are involved: first stage is used to obtain linear combination using this assumption and second stage estimates the number of remaining noise. Greedy time-frequency shrinkage based sparse audio de-noising is discussed in [3]. Matching pursuit in the background of audio de-noising is analysed. Factors critical to its success is identified using interpreting the algorithm like easy shrinkage approach.

Spectral subtraction technique based audio de-noising is explained in [4]. An efficient architecture in hardware for the algorithm of spectral subtraction is applied to speech improvement is used. Environmental noise is estimated from speech adaptively. Noise samples are subtracted in the input speech after the noise estimation. There are two principal blocks are followed like phase block and noise estimation-subtraction block which are executed simultaneously exploiting the parallel logic blocks of field programmable gate array.

De-noising approach based on statistical Empirical Mode Decomposition (EMD) for multi rate high-resolution signal reconstruction is presented in [5]. De-noising procedure is applied based on EMD interval-threshold to every noisy low resolution measurement. Then only can filter the AWGN.

STFT and wavelet de-noising based Linear Frequency Modulated (LFM) Signals Detection in low SNR is explained in [6]. Input signals are short-time Fourier transformed into coherent integration of frequency-shift model sequences with compound envelopes, achieving a time-frequency curve which is to be processed by wavelet, in order to weaken the noise and to detect LFM signals effectively. The impulse noise reduction is presented an efficient approach for the removal of bipolar impulse noise using median filter [7]. The denoising process can also be done for denoising the Ultrasonic Echo signals as in [9]. Empirical mode decomposition based denoising method for heart sound signal and its performance analysis is discussed in [10]. Also the denoising process can also be used for applications like SAR Image Denoising as in [11].

### 3. PROBLEMS

Usually when the signals are transmitted over a distance by any means there may be some problems occurred due to the noises that are affected by the means of the environment. So due to this there may be noises added to the signal which affects the information that are stored in it. So in order to lessen the noise in an efficient way our proposed methods is introduced.

### 4. PROPOSED SOLUTION

The proposed system uses the STFT block threshold method. It is used to de-noising the audio signal effectively. First the given input signals are read then AWGN noise is used to add some noise to the input audio signals. The reduction of noise in the diesel engines is explained in the Exhaust noise reduction techniques in direct injection (D.I.) diesel engines [8]. Then the noised signals are de-noised using this novel STFT technique. Finally SNR and PSNR of the original and de-noised signals value are calculated. Figure 1 shows the block diagram of the proposed audio de-noising technique.

### 5. METHODOLOGY

#### 5.1. Short Time Fourier Transform

The STFT is also called as short-term Fourier transform because it is a Fourier-related transform to determine the sinusoidal frequency and phase content of local sections of a signal. Longer time signal is divided into shorter segments while computing STFT in practice and then calculates the Fourier transform individually on every shorter segment.

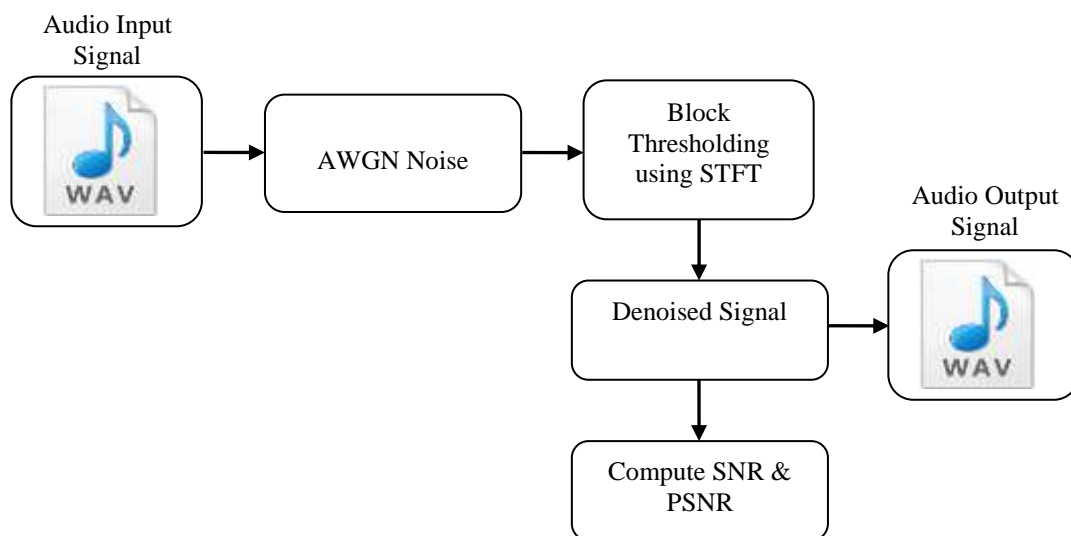

Figure 1. Block Diagram of the Proposed Audio De-Noising System

This reveals the Fourier spectrum on every shorter segment. One then usually plots the varying spectra as a time function. Figure 2 shows the example of STFT.

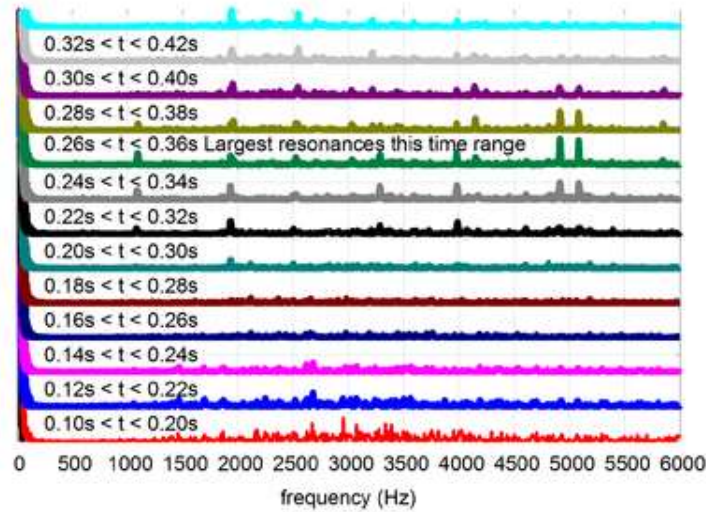

Figure 2. STFT Diagram

**6. RESULTS & DISCUSSIONS**

The performance of the proposed system for digital audio de-noising using STFT method has done. The proposed architecture uses a novel approach to estimate environmental noise from speech adaptively. Here original speech signals are given as input signal. Using AWGN, noises are added to the signal. Then noised signals are de-noised using STFT techniques. Finally SNR, PSNR values for noised and de-noised signals are obtained.

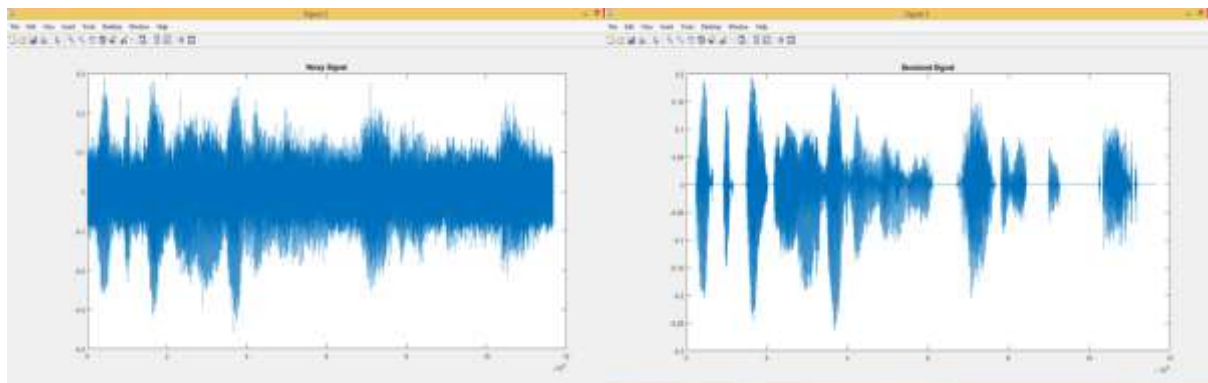

Figure 3. Noisy Signal using AWGN

Figure 4. De-Noise Audio Signal using STFT

Figure 2 shows the noised signal which we used. Here the noises were added using add white Gaussian noise method with SNR rate. Figure 3 shows the de-noised output audio signal. The de-noising is based on STFT with block threshold method and hanning window.

**7. CONCLUSION**

In this paper, STFT has been proposed to de-noise an audio signal from the given input signal. Figure 4 shows the de-noised audio signal using STFT method. Finally PSNR of this proposed method is better while compared to existing method. The results indicate that this performs better than the other distributions. The future scope of this paper is designing a better algorithm with better features.

**REFERENCES**

- [1] Han K, Wang Y, Wang D, Woods WS, Merks I, Zhang T. Learning spectral mapping for speech dereverberation and denoising. *IEEE Transactions on Audio, Speech, and Language Processing*. 2015; 23(6): 982-992.
- [2] Bayram I. A multichannel audio denoising formulation based on spectral sparsity. *IEEE/ACM Transactions on Audio, Speech and Language Processing*. 2015; 23(12): 2272-2285.
- [3] Bhattacharya G, Depalle P. *Sparse denoising of audio by greedy time-frequency shrinkage*. IEEE International Conference on Acoustics, Speech and Signal Processing. 2014: 2898-2902.
- [4] Biswas T, Pal C, Mandal SB, Chakrabarti A. *Audio de-noising by spectral subtraction technique implemented on reconfigurable hardware*. IEEE Seventh International Conference on Contemporary Computing. 2014: 236-241.
- [5] Ukte A, Kizilkaya A, Elbi MD. *Statistical multirate high-resolution signal reconstruction using the empirical mode decomposition based denoising approach*. IEEE International Conference on Applied Electronics. 2014: 303-306.
- [6] Yu D, Jinzhen W, Shaoying S, Zengping C. *Detection of LFM signals in low SNR based on STFT and wavelet denoising*. IEEE International Conference on Audio, Language and Image Processing. 2014: 921-925.
- [7] Kadali KS, Rajaji L. An efficient approach for the removal of bipolar impulse noise using median filter. *Indian Journal of Science and Technology*. 2015; 8(13).
- [8] Sundara Raman R, Sankara Narayanan, G, Manoharan N. Exhaust noise reduction techniques in direct injection (D.I.) diesel engines, *International Journal of Applied Engineering Research*. 2014; 9(18): 3949-3954.
- [9] Mishra S. Cascade combination of wavelet and adaptive filter for noise cancellation. *International journal of advances in signal and image sciences*. 2016; 2(2): 21-26.
- [10] Mohammadi MHD. Improved Denoising Method for Ultrasonic Echo with Mother Wavelet Optimization and Best-Basis Selection. *International Journal of Electrical and Computer Engineering*. 2016; 6(6): 2742-2754.
- [11] Salman AH, Ahmadi N, Mengko R, Langi AZ, Mengko TL. Empirical Mode Decomposition (EMD) Based Denoising Method for Heart Sound Signal and Its Performance Analysis. *International Journal of Electrical and Computer Engineering*. 2016; 6(5): 2197-2204.
- [12] Subramanyam MV, Prasad G. A New Approach for SAR Image Denoising. *International Journal of Electrical and Computer Engineering*. 2015; 5(5): 984-991.