

Automatic Door Access System Using Face Recognition

Hteik Htar Lwin, Aung Soe Khaing, Hla Myo Tun

Abstract: Most doors are controlled by persons with the use of keys, security cards, password or pattern to open the door. The aim of this paper is to help users for improvement of the door security of sensitive locations by using face detection and recognition. Face is a complex multidimensional structure and needs good computing techniques for detection and recognition. This paper is comprised mainly of three subsystems: namely face detection, face recognition and automatic door access control. Face detection is the process of detecting the region of face in an image. The face is detected by using the Viola Jones method and face recognition is implemented by using the Principal Component Analysis (PCA). Face Recognition based on PCA is generally referred to as the use of Eigenfaces. If a face is recognized, it is known, else it is unknown. The door will open automatically for the known person due to the command of the microcontroller. On the other hand, alarm will ring for the unknown person. Since PCA reduces the dimensions of face images without losing important features, facial images for many persons can be stored in the database. Although many training images are used, computational efficiency cannot be decreased significantly. Therefore, face recognition using PCA can be more useful for door security system than other face recognition schemes.

Keywords: Viola-jones face detection method, PCA, Eigenvector, Covariance, Euclidean distance, Eigenface, microcontroller

I. INTRODUCTION

Nowadays, automatic personal identification in access control has become popular by using biometrics data instead of using cards, passwords or pattern. Most of the biometrics data have to be collected by using special hardware such as fingerprint scanner, palm print scanner, DNA analyzer. And, the target objects have to touch with the required hardware in the stage of data collection. The advantage of this system is that face recognition does not require to be touched with any hardware. Face is detected automatically by using face detection technique and the entire face recognition is completed without touching with any hardware. Face detection is the first step of the face recognition system. The performance of the entire face recognition system is influenced by the reliability of the face detection. By using face detection, it can identify only the facial part of an image regardless of the background of this image. In this system, Viola-Jones face detection method is used. Viola-Jones rescales the detector instead of the input image and runs the detector many times through the image – each time with a different size. Viola-Jones have devised a scale invariant detector that requires the same number of calculations whatever the size. This detector is constructed using a so-called integral image and some simple rectangular features reminiscent of Haar wavelets [1]. Face recognition commonly includes feature extraction, feature reduction and recognition or classification. PCA is an effective feature extraction method based on face as a global feature. It reduces the dimension of images effectively and holds the primary information at the same time. In this paper, face recognition system is implemented using PCA algorithm. Recognition or classification is done by the measure method such as Euclidean distance, which is used to classify the feature of images present in the database and test image. [2].

In this system, face detection and recognition are implemented by using MATLAB installed on PC. USB to RS232 converter is used as the interface between the PC and 16F887 microcontroller. Edge sensors are used to switch off the motor if the door reaches one of its two end positions. This switching mainly works with an algorithm which is loaded in microcontroller and on the basis of serial port data which is sent by PC after verifying the face. The overall block diagram of this system is shown in figure 1.

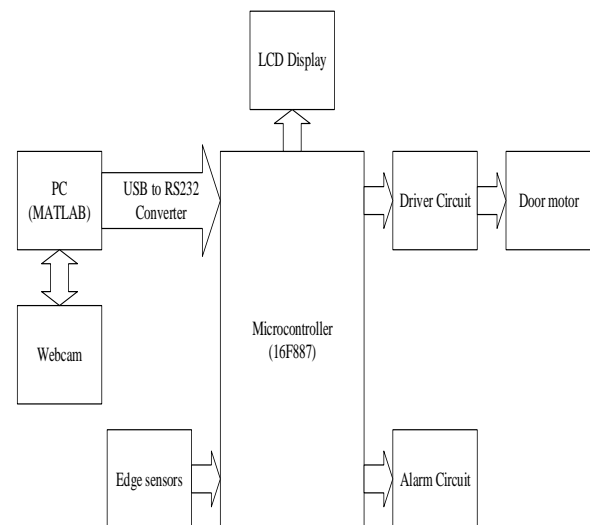

Figure.1. Overall block diagram of automatic door access system using face recognition

II. METHODOLOGY

A. Viola-Jones Face Detection Method

This method consists of three main steps. The first step of the Viola-Jones face detection algorithm is to turn the input image into a new image representation called an integral image that allows a very fast feature evaluation. The used features are reminiscent of Haar basis functions. The Viola-Jones method analyzes a 24*24 sub-window using features consisting of two or more rectangles. Each feature results in a single value which is calculated by subtracting the sum of the

- Hteik Htar Lwin, Aung Soe Khaing, Hla Myo Tun
- Department of Electronic Engineering, Mandalay Technological University, Mandalay
- hteikhtarlwin1991@gmail.com

whiterectangle(s) from the sum of the black rectangle(s) [4]. The different types of features are shown in Figure 2.

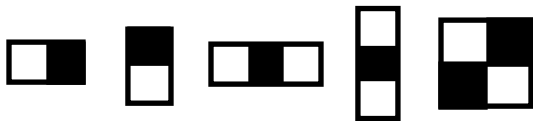

Figure.2. Different types of features

For a fast processing of these features, the integral image representation is used. This is done by making each pixel equal to the entire sum of all pixels above and to the left of the concerned pixel [3]. It is calculated by the following equation

$$ii(x, y) = \sum_{x' \leq x, y' \leq y} i(x', y') \quad [1]$$

where $ii(x, y)$ is the integral image and $i(x, y)$ is the original image. The integral image can be computed in one pass over the original image by using the following pair of recurrences:

$$s(x, y) = s(x, y - 1) + i(x, y)$$

$$ii(x, y) = ii(x - 1, y) + s(x, y)$$

where $s(x, y)$ is the cumulative row sum, $s(x, -1) = 0$, and $ii(-1, y) = 0$. The second step is constructing a classifier in order to select a small number of important features using AdaBoost learning algorithm. AdaBoost is a machine learning boosting algorithm capable of constructing a strong classifier through a weighted combination of weak classifiers [4]. A weak classifier is calculated by the following equation

$$h(x, f, p, \theta) = \begin{cases} 1 & \text{if } pf(x) < p\theta \\ 0 & \text{otherwise} \end{cases}$$

where x is a 24*24 pixel sub-window of an image, f is the applied feature, p indicates the direction of the inequality, and θ is a threshold that decides whether x should be classified as a positive (a face) or a negative (a non-face). The final strong classifier is obtained after applying the adaboost algorithm detailed in [1]. In the third step, the cascaded classifier is used to determine whether a given sub-window classifier is definitely not a face or maybe a face. The cascaded classifier is composed of stages in which each consists of a strong classifier. The concept is illustrated with two stages in figure 3.

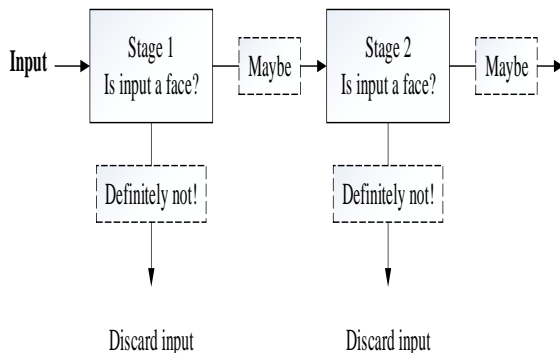

Figure.3. Cascaded classifier[4]

B. Principal Component Analysis

To extract the relevant features of facial images, Principal Component Analysis (PCA) method is used. Face Recognition based on PCA is generally referred to as the use of Eigenfaces. Eigen faces are Principal Components of the distribution of faces, or equivalently, the Eigen vectors of the covariance matrix of the set of the training images, where an image with N by N pixels is considered as a point in N^2 dimensional space [5]. The PCA algorithm is shown in the following steps:

Step-1. Firstly, the image matrix I of size $(N \times N)$ pixels is converted to the image vector Γ of size $(P \times 1)$ where $P = (N \times N)$.

Training Set: $\Gamma = [\Gamma_1 \Gamma_2 \dots \Gamma_M]$

Step-2. Average face image is calculated by

$$\Psi = \frac{1}{M} \sum_{i=1}^M \Gamma_i$$

Each face differs from the average by $\Phi_i = \Gamma_i - \Psi$

Difference Matrix: $A = [\Phi_1 \Phi_2 \dots \Phi_M]$

Step-3. A covariance matrix is constructed as:

$C = A A^T$, where size of C is $(P \times P)$.

- This covariance matrix is very hard to work with due to its huge dimension that causes computational complexity.
- The covariance matrix with reduced dimensionality is

$L = A^T A$, where size of L is $(M \times M)$.

In order to obtain the eigenvectors of the original covariance matrix, it can be calculated by the following equations:

$$A^T A X_i = \lambda_i X_i$$

By multiplying both sides of the above equation with A ,

$$A A^T A X_i = A \lambda_i X_i \quad A A^T (A X_i) = \lambda_i (A X_i)$$

- $A X_i$ are the Eigenvectors of the covariance matrix which is denoted by U_i and eigenvalues λ_i are the same for the two covariance matrix.

Step-4. A face image can be projected into this face space by

$$\Omega_k = U_k^T \Phi_i$$

Step-5. Test image vector: Γ_t

Mean subtracted image vector:

$$\Phi_t = \Gamma_t - \Psi$$

The test image is projected into the face space to obtain a vector:

$$\Omega = U_k^T \Phi_t$$

C. Classification

Classification is finding the minimum distance between the test image and the training images. The face with minimum Euclidian distance shows the similarity to test image. The distance of test image Ω to each training image is called Euclidean distance and is defined by,

$$\epsilon_k^2 = || \Omega - \Omega_k ||^2 \quad [5]$$

By choosing a threshold value θ that is the maximum acceptable value for known images and comparing it with the minimum ϵ_k , test image can be recognized as known or unknown face image.

If $\epsilon_{k(\min)} \geq \theta$, the test image is recognized an unknown face.

If $\epsilon_{k(\min)} < \theta$, the test image is a known face.

III. HARDWARE DESIGN

The hardware configuration of this system is composed of microcontroller (PIC 16F887), L298 driver IC, opto-isolators, LCD display, USB to RS232 converter, DC motor and buzzer. USB to RS232 converter is used as the interface between personal computer and the microcontroller. Opto-isolators are used as the inputs of the microcontroller and other components are used as outputs of the microcontroller.

A. USB To RS232 Converter

In order to adjust the voltage level between PC and the microcontroller, this converter is used. The driver had already installed on PC that converts the USB connection into a Virtual Communications Port, which makes the USB connection that looks like a serial port on the PC. Figure 4 shows USB to RS232 converter.



Figure.4. USB to RS232 converter

B. PIC Microcontroller

This system used PIC 16F887 microcontroller because of its good features and integrated peripherals. The microcontroller is used to receive the signal sent from PC and to send a command back either to the door motor circuit or to the alarm circuit. Figure 5 shows PIC 16F887 microcontroller pins assign.

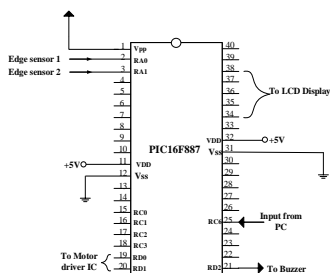

Figure.5. PIC16F887 microcontroller pins assign.

C. Opto-isolator

The two opto-isolators are used as the edge sensors for automatic door opening and closing system. An opto-coupler shown in figure 6 involves a LED and a phototransistor. When an electrical signal is applied to the input of the opto-isolator, its LED lights, its light sensor activates, and the output is low. If an obstacle is placed between its LED and its phototransistor, the output is high.

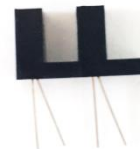

Figure.6. Opto-isolator

D. L298 Driver IC

Each digital pin of the microcontroller PIC16F887 can supply maximum 25mA. However, the DC motor can sink more current. Since the microcontroller can't supply the needed amount of current, L298 driver IC is required as the interface between the microcontroller and the motor. Figure 7 shows the L298 driver IC pins assign.

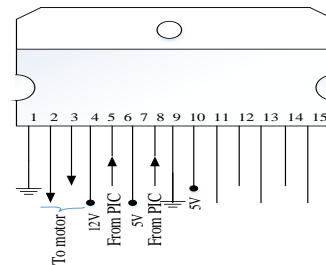

Figure.7. L298 Driver IC pins assign

IV. IMPLEMENTATION

There are two parts in this implementation step. The first is the implementation of face detection and face recognition system by using MATLAB. And the second is the implementation of PIC16F887 program for door access system.

A. Implementation of Face Detection And Recognition

Matlab2014a is used for coding. In the database folder, 50 different facial parts of images for ten persons are used as the training images. While making the database folder, the captured images are applied and cropped by face detection module in order to obtain the only facial parts of all images with different directions. For instance, five images of a person with different face directions are shown in figure 8.



Figure.8. Five different images for a single face image

All training images are reshaped and converted into 125x125 grayscale images by using `resize` and `rgb2gray` matlab built-in function. Mean centered (or subtracted) images are evaluated by subtracting average image from the original training image. The eigenvectors corresponding to the covariance matrix define the Eigen faces which look like ghostly faces. Since 50 training images are used, 50 eigenfaces are obtained. Some eigenfaces of the training images are shown in figure 9.



Figure.9. Some eigenfaces of the training images

The trained and test images are projected onto the facespace where the eigenfaces are the coordinates or dimensions to find their respective euclidian distance. By comparing the euclidian distance of all projected trained images with the projected test image, minimum distance between them which shows similarity to test image is obtained. By this way, the facial image recognition was done.

B. Microcontroller Program Implementation

The overall program for PIC16F887 is implemented by using the MikroC language. It was created according the flowchart for the automatic door opening and closing system shown in figure 10. Firstly, it have to assign the required I/O pins and check whether the data is received or not. When the received data is 'known', the motor is rotated in the forward direction until the edge sensor 1 is activated. Running motor is stopped when sensor 1 is activated. After 2 seconds, motor is rotated with reverse direction. When the edge sensor 2 is activated, the motor is stopped.

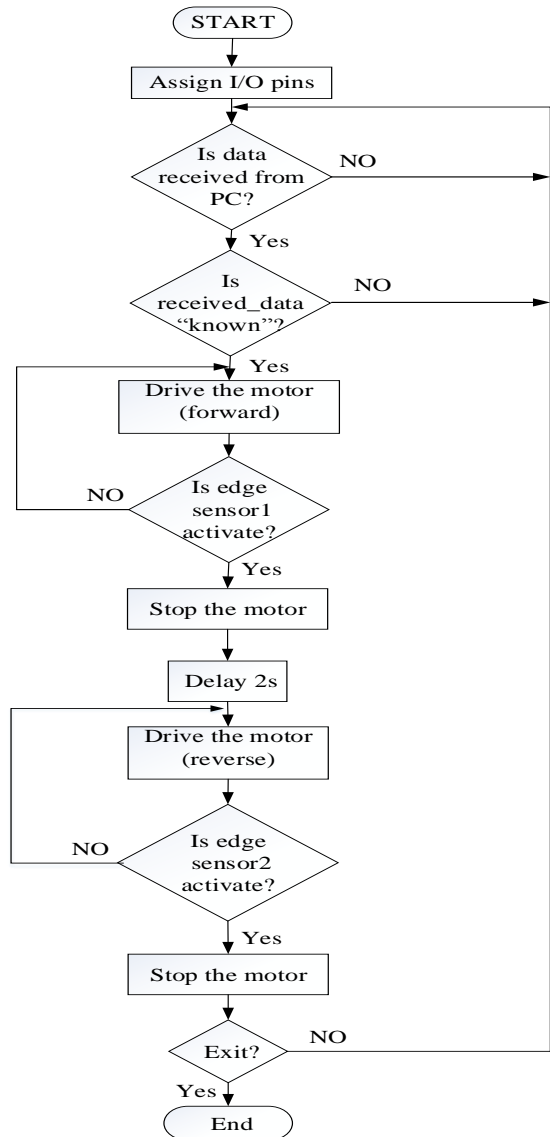

Figure.10. Flowchart for the automatic door opening and closing system

V. SIMULATION TESTS AND RESULTS

The overall automatic door access system using face recognition is simulated by using PROTEUS software and MATLAB. VSPE software is used to create a virtual serial communication port. A MATLAB GUI is created in order to perform automatic face detection and recognition. There are two cases in this system. The first is automatic door opening for the recognized person and the second is ringing the alarm for the unauthenticated person. In this system, input images are taken through a web camera continuously until the 'stop camera' button is pressed. Figure 11 shows the MATLAB GUI result when captured face is detected and recognized as authenticated person.

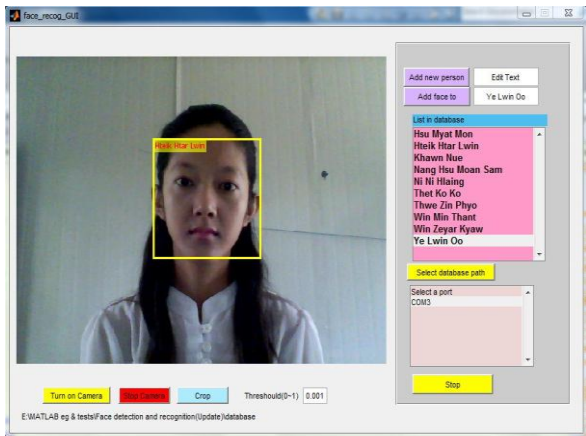

Figure.11. Matlab GUI result when captured face is detected and recognized as authenticated person

When the captured image is recognized as the authenticated person, door motor is rotated with the forward direction until the edge sensor 1 is activated. When the sensor 1 is activated, the door motor is stopped. After 2 seconds, door motor is rotated with reverse direction until edge sensor 2 is activated. Figure 12 and 13 show the simulation result for authenticated person.

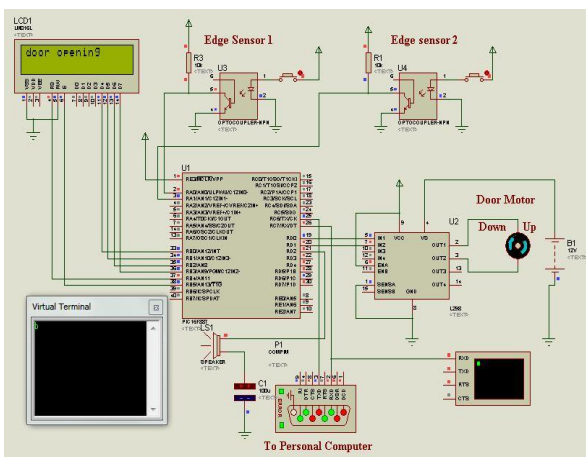

Figure.12. Simulation result when the door motor is rotated with forward direction for authenticated person

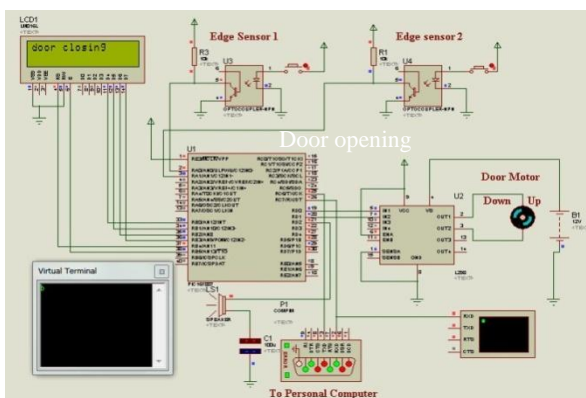

Figure.13. Simulation result when the door motor is rotated with reverse direction for authenticated person

When the captured image is recognized as unauthenticated person, alarm is rung and door is still closed. This simulation result is shown in figure 14.

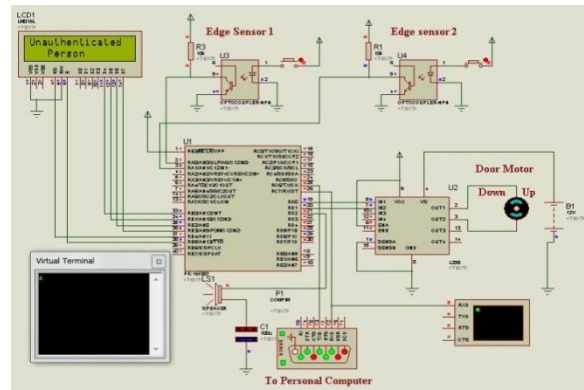

Figure.14. Simulation result for unauthenticated person

VI. HARDWARE RESULTS

To perform automatic door access system, personal computer (PC) is connected with the microcontroller via USB to RS232 converter. When no face is detected in front of the webcam, any signal is not sent to the microcontroller. Since microcontroller is not received any signal from PC, the door remains closed. This situation is shown in figure 15.

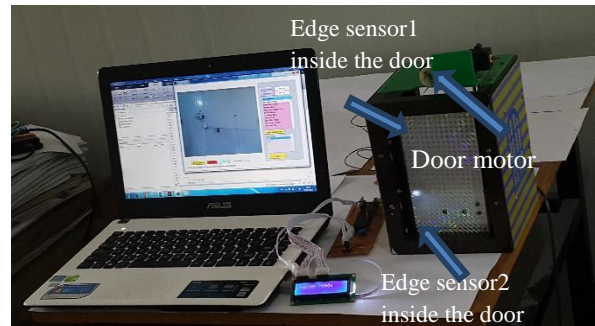

Figure.15. Hardware test for normal condition when no face is detected

When face is detected, the name of the recognized person is shown in the left corner of the detecting box on MATLAB GUI. Once the face is recognized, the door is opened automatically as shown in figure 16.

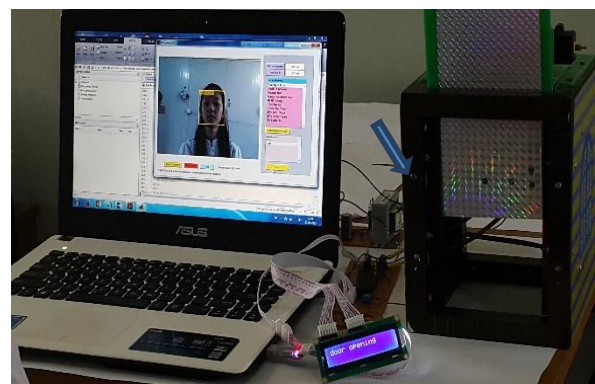

Figure.16. Hardware test for authenticated person

As shown in figure 17, since there is no facial image of this person in the database folder, this person is recognized as unauthenticated person.



Figure.17. Hardware test for unauthenticated person

VII. DISCUSSIONS AND CONCLUSIONS

In this paper, automatic door access system by using face recognition and detection is presented. Automatic face detection and recognition is done by Matlab program on PC. Microcontroller is used to control the door access system depending on the incoming data sent from the personal computer (PC). Door is opened immediately after confirming that the person is authenticated. After 2 seconds, door is closed automatically. However, in real time, 2 seconds are not enough time to enter a person. So, longer time should be set for real-time condition. Viola-Jones face detection method is used to detect the location of the face in an image. Since this detection method can detect only face images for frontal view correctly, this system has limitations in head orientation. For face recognition, Principal Component Analysis method is used to extract the important features of facial images. Since PCA method reduces the dimension of the dataset, this system can detect and recognize an image within one second. Therefore, this system can be used in automatic verification of people to improve door security for strangers without needing security guards and wasting too many time.

ACKNOWLEDGMENT

The author would like to express her gratitude to all her teachers from Department of Electronic Engineering, Mandalay Technological University. And, she deeply thanks to her parents for their encouragement and support and especially thanks to her friends for giving the chance to take their face images utilized in this paper.

REFERENCES

- [1] Paul Viola, Michael J. Jones, Robust Real-Time Face Detection, International Journal of Computer Vision 57(2), 2004.
- [2] Ayushi Gupta, Ekta Sharma, Neha Sachan and Neha Tiwari. Door Lock System through Face Recognition Using MATLAB. International Journal of Scientific Research in Computer Science and Engineering, Vol-1, Issue-3, 30 June 2013.
- [3] Daniel Georgescu, A Real-Time Face Recognition System Using Eigenfaces, Journal of Mobile,

Embedded and Distributed Systems, vol. III, no. 4, 2011.

- [4] Ole Helvig Jensen, Implementing the Viola-Jones Face Detection Algorithm, 2008.
- [5] M. A. Turk and A. P. Pentland. Eigenfaces for Recognition. Journal of Cognitive Neuroscience, 3(1):71 - 86, 1991.
- [6] M. A. Turk and A. P. Pentland. Face recognition using eigenfaces. IEEE Computer Society Conference on Computer Vision and Pattern Recognition, CVPR 91, pages 586 - 591, 1991.
- [7] I.Yugashini, S. Vidhyasri, K.Gayathri Devi, Design And Implementation Of Automated Door Accessing System With Face Recognition, International Journal of Science and Modern Engineering(IJSME), Volume-1, Issue-12, November 2013.
- [8] Liton Chandra Paul, Abdulla Al Sumam. Face Recognition Using Principal Component Analysis Method. International Journal of Advanced Research in Computer Engineering & Technology (IJARCET), Volume 1, Issue 9, November 2012.