

# Automatic Modeling and Validation of Pipeline Specifications driven by an Architecture Description Language\*

Prabhat Mishra<sup>†</sup> Hiroyuki Tomiyama<sup>‡</sup> Ashok Halambi<sup>†</sup> Peter Grun<sup>†</sup> Nikil Dutt<sup>†</sup> Alex Nicolau<sup>†</sup>

<sup>†</sup>Center for Embedded Computer Systems  
University of California, Irvine, CA 92697  
{pmishra, ahalambi, pgrun, dutt, nicolau}@cecs.uci.edu

<sup>‡</sup>Inst. of Systems & Information Tech.  
Fukuoka 814-0001, Japan  
tomiyama@isit.or.jp

## Abstract

*Verification is one of the most complex and expensive tasks in the current Systems-on-Chip (SOC) design process. Many existing approaches employ a bottom-up approach to pipeline validation, where the functionality of an existing pipelined processor is, in essence, reverse-engineered from its RT-level implementation. Our approach leverages the system architect's knowledge about the behavior of the pipelined architecture, through Architecture Description Language (ADL) constructs, and thus allows a powerful top-down approach to pipeline validation. This paper addresses automatic validation of processor, memory, and co-processor pipelines described in an ADL. We present a graph-based modeling of architectures which captures both structure and behavior of the architecture. Based on this model, we present formal approaches for automatic validation of the architecture described in the ADL. We applied our methodology to verify several realistic architectures from different architectural domains to demonstrate the usefulness of our approach.*

## 1 Introduction

Verification is one of the most complex and expensive tasks in the current System-On-Chip design process. In current state-of-the-art verification methodology, the architect prepares an informal specification in the form of an English document. The logic designer implements the modules and verifies them in an ad-hoc manner using simulation test vectors since there is no golden reference model for validation. A key challenge in today's design verification is to extract the information from the RT level description and to perform equivalence checking with the model extracted from the given specification (written in English language). Many existing approaches ([5], [8]) employ a bottom-up approach to pipeline validation, where the functionality of an existing pipelined processor is, in essence, reverse-engineered from its RT-level implementation. Hauke et al. [5] compare extracted ISA level description with the given ISA level specification. Ho et al. [3] extract

controlled token nets from a logic design to perform efficient model checking. Our verification technique is complimentary to these bottom-up approaches. We leverage the system architect's knowledge about the behavior of the pipelined architecture through ADL constructs, which allows a powerful top-down approach to pipeline verification using behavioral knowledge of the pipelined architecture. The ADL description also serves as a golden reference model. Furthermore, ADL driven verification is a natural choice during rapid design space exploration(DSE) of System-on-Chip(SOC) architectures.

In this paper, we present an automatic validation framework, driven by an ADL. A novel feature of our approach is the ability to model the pipeline structure and behavior for the processor, co-processor, as well as the memory subsystem using a graph-based model. Based on this model we present formal approaches for automatic validation of the architecture described in an ADL. We applied our methodology to verify several realistic architectures from different architectural domains (RISC, DSP, VLIW, and Superscalar) to demonstrate the usefulness of our approach.

The rest of the paper is organized as follows. Section 2 presents related work addressing ADL-driven validation approaches. Section 3 outlines our approach and the overall flow of our environment. Section 4 presents a graph-based modeling of processor, memory, and co-processor pipelines. Section 5 proposes several properties that must be satisfied for valid pipeline specification. Section 6 illustrates validation of pipeline specifications for several realistic architectures. Finally, Section 7 concludes the paper.

## 2 Related Work

Recent work on language-driven Design Space Exploration (DSE) ([1], [2], [4], [12]), uses Architectural Description Languages (ADL) to capture the processor and memory architecture, generate automatically a software toolkit (including compiler, simulator, assembler) for that architecture, and provide feedback to the designer on the quality of the architecture. It is necessary to verify that the ADL description of the architecture is well-formed prior to generating software

\*This work was partially supported by grants from NSF (MIP-9708067), DARPA (F33615-00-C-1632), Motorola Inc. and Hitachi Ltd.

toolkits. The process of any specification is error-prone and validation techniques can be used to check for correctness of the specification. Moreover, changes made to the architecture during design space exploration may result in incorrect execution of the system and validation techniques can be used to ensure correctness of the architecture.

The work of Tomiyama et al. [9, 10] is a step in this direction. They defined certain properties that need to be verified to ensure that the architecture description is well-formed. However, the properties they proposed are applicable to simple processor models. Moreover, they do not demonstrate how these properties can be applied in SOC verification during design space exploration. Mishra et al. [11] presented a graph based validation of processor cores and is closest to our approach. Our work extends this technique to validate pipeline specifications of coprocessors and memory subsystem along with processor cores.

### 3 Our Approach

Figure 1 shows the flow in our approach. In our ADL driven design space exploration scenario, the designer starts by describing the programmable architecture in an ADL. The graph model of the architecture can be generated automatically from this ADL description. Several properties are applied automatically to ensure that the architecture is well-formed. To enable rapid DSE the software toolkit can be generated from this golden reference model and the feedback can be used to modify the ADL description of the architecture. This golden reference model can also be used to verify the implementation by performing equivalence checking with the reverse-engineered description of the implementation..

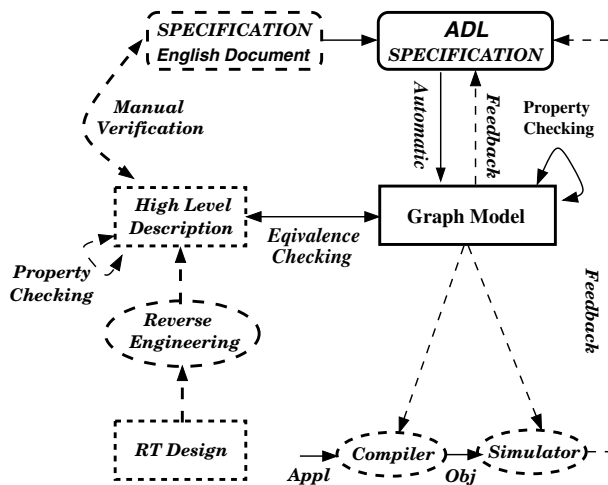

Figure 1. ADL-driven validation flow

### 4 Architecture Pipeline Modeling

We develop a graph-based modeling of architecture pipelines which captures both the structure and the behavior. The graph model presented here can be derived from a pipeline specification of the architecture described in an

ADL e.g., EXPRESSION [1]. This graph model can capture processor, memory, and co-processor pipelines for wide variety of architectures viz., RISC, DSP, VLIW, Superscalar, and Hybrid architectures. Note that it is important to capture the memory pipeline along with processor pipeline, since any memory operation exercises both the processor and memory pipeline structures [13]. In this section we briefly describe how we model the structure, behavior and the mapping functions between them. The detailed description of the modeling can be found in [7].

#### 4.1 Structure

The structure of an architecture pipeline is modeled as a graph  $G_S$

$$G_S = (V_S, E_S). \quad (1)$$

$V_S$  denotes a set of components in the architecture.  $V_S$  consists of four types of components

$$V_S = V_{unit} \cup V_{store} \cup V_{port} \cup V_{conn} \quad (2)$$

where  $V_{unit}$  is a set of *units* (e.g., ALUs),  $V_{store}$  a set of *storages* (e.g., register files, caches),  $V_{port}$  a set of *ports*, and  $V_{conn}$  a set of *connections* (e.g., buses).  $E_S$  consists of two types of edges

$$E_S = E_{data\_trans} \cup E_{pipeline} \quad (3)$$

where  $E_{data\_trans}$  is a set of *data-transfer edges* and  $E_{pipeline}$  is a set of *pipeline edges*.

$$E_{data\_trans} \subseteq V_{unit} \times V_{port} \cup V_{store} \times V_{port} \cup V_{port} \times V_{conn} \cup V_{conn} \times V_{port} \cup V_{port} \times V_{unit} \cup V_{port} \times V_{store} \quad (4)$$

$$E_{pipeline} \subseteq V_{unit} \times V_{unit} \quad (5)$$

A data-transfer edge  $(v_1, v_2) \in E_{data\_trans}$  indicates connectivity of the two components. Through data-transfer edges, data is transferred from components to components. A pipeline edge specifies the ordering of units comprising the pipeline stages (or simply pipe-stages). Intuitively, operations flow from pipe-stages to pipe-stages through pipeline edges. Both pipeline edges and data-transfer edges are uni-directional. Bi-directional data-transfers are modeled using two edges of different directions.

For illustration, we use a simple multi-issue architecture containing one co-processor and a memory subsystem. Figure 2 shows the graph-based model of this architecture that can issue up to three operations (an ALU operation, a memory access operation and one coprocessor operation) per cycle. In the figure, normal boxes denote units, dotted boxes are storages, small circles are ports, shaded boxes are connections, bold edges are pipeline edges, and dotted edges are data-transfer edges. For ease of illustration, we have shown only few ports and connections. Each component has several attributes. The figure shows only two of them viz., *capacity* and *timing* for some of the nodes. The capacity denotes the maximum number of operations which the component can

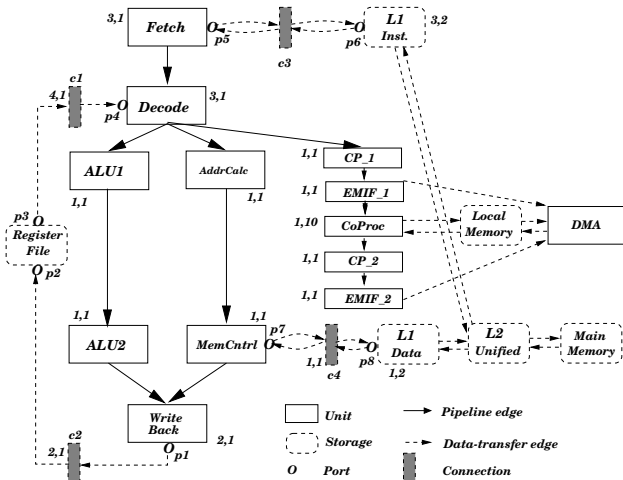

Figure 2. A structure graph of a simple architecture

handle in a cycle, while the timing denotes the number of cycles taken by the component to execute them. A path from a root node (e.g., fetch unit) to a final node (e.g. WriteBack unit) consisting of units and pipeline edges is called a *pipeline path*. Intuitively, a pipeline path denotes an execution flow in the pipeline taken by an operation. For example, one of the pipeline path is  $\{Fetch, Decode, ALU1, ALU2, WriteBack\}$ . A path from an unit to main memory or register file consisting of storages and data-transfer edges is called a *data-transfer path*. For example,  $\{MemCntrl, L1, L2, MainMemory\}$  is a data-transfer path. A memory operation traverses different data-transfer paths depending on where it gets the data in the memory. For example, a load operation which is hit in L2 will traverse the path (includes pipeline and data-transfer paths)  $\{Fetch, Decode, AddrCalc, MemCntrl, L1, L2(hit), L1, MemCntrl, WriteBack\}$ . Similarly, a co-processor operation will traverse the path  $\{Fetch, Decode, CP_1, EMIF_1, CoProc, CP_2, EMIF_2\}$ . However, in this path we have not shown different data transfers. For example, EMIF\_1 sends read request to DMA and DMA writes data in coprocessor local memory which coprocessor uses during computation and writes the result back and finally EMIF\_2 requests DMA to write the result back to main memory.

## 4.2 Behavior

The behavior of an architecture is a set of operations that can be executed on it. Each operation in turn consists of a set of fields (e.g. opcode, arguments) that specify, at an abstract level, the execution semantics of the operation. We model the behavior as a graph  $G_B$ , consisting of nodes  $V_B$  and edges  $E_B$ .

$$G_B = (V_B, E_B) \quad (6)$$

The nodes represent the fields of each operation, while the edges represent orderings between the fields. The behavior graph  $G_B$  is a set of disjointed sub-graphs, and each sub-graph is called an *operation graph* (or simply an operation). Figure 3 describes a portion of the behavior (consisting of two operation graphs) for the example processor in Figure 2. Nodes

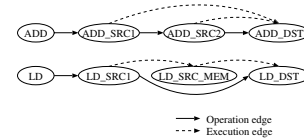

Figure 3. A fragment of the behavior graph

are of two types:  $V_{opc}$  is a set of opcode nodes that represent the opcode (i.e. mnemonic), and  $V_{arg}$  is a set of argument nodes that represent argument fields (i.e., source and destination arguments). Each operation graph must have one opcode node. In Figure 3, the ADD and LD nodes are opcode nodes, while the others are argument nodes.

$$V_B = V_{opc} \cup V_{arg} \quad (7)$$

$$E_B = E_{oper} \cup E_{exec} \quad (8)$$

Edges between the nodes are also of two types. Both types of edges are uni-directional.  $E_{oper}$  is a set of operation edges that link the fields of the operation and also specify the syntactical ordering between them. For each operation graph, operation edges must construct a path containing an opcode node. On the other hand,  $E_{exec}$  is a set of execution edges that specify the execution ordering between the argument nodes.

$$E_{exec} \subseteq V_{arg} \times V_{arg} \quad (9)$$

There must be no cycles consisting of execution edges. In Figure 3, the solid edges represent operation edges while the dotted edges represent execution edges. For the ADD operation, the operation edges specify that the syntactical ordering is opcode followed by ADD\_SRC1, ADD\_SRC2 and ADD\_DST arguments (in that order) and the execution edges specify that the ADD\_SRC1 and ADD\_SRC2 arguments are executed (i.e., read) before the ADD\_DST argument is written.

## 4.3 Mapping Between Structure and Behavior

Another component of our graph model is a set of functions that correlate the abstract, high-level behavioral model of the processor to the structural model. Below, we define a set of useful mapping functions that map nodes in the structure to nodes in the behavior (or vice-versa).

The *units-to-opcodes (opcodes-to-units)* mapping is a bi-directional function that maps unit nodes in the structure to opcode nodes in the behavior. It defines, for each functional unit, the set of operations supported by that unit (and vice versa).

$$f_{unit-opcode} : V_{unit} \rightarrow V_{opc} \quad (10)$$

$$f_{opcode-unit} : V_{opc} \rightarrow V_{unit} \quad (11)$$

For the example processor in Figure 2, the  $f_{unit-opcode}$  mappings include mappings from Fetch to ADD, Fetch to LD, ALU to ADD, AddrCalc to LD, etc.

The *arguments-to-storages (storages-to-arguments)* mapping is a bi-directional function that maps argument nodes in the behavior to storage nodes in the structure. It defines, for each argument of an operation, the storage location that the argument resides in.

$$f_{arg-storage} : V_{arg} \rightarrow V_{store} \quad (12)$$

$$f_{storage-arg} : V_{store} \rightarrow V_{arg} \quad (13)$$

The  $f_{arg-storage}$  mappings for the LD operation are mappings from LD\_SRC1 to RegisterFile, from LD\_SRC\_MEM to L1(Data Memory), and from LD\_DST to RegisterFile.

We can generate a graph-model of the architecture from an ADL description that has information regarding architecture's structure, behavior, and the mapping between them. We have chosen the EXPRESSION ADL [1] since it captures all the necessary information. We generate automatically the graph model of the architecture pipeline consisting of structure graph, behavior graph and mapping between them using the modeling techniques described above. For details on how the graph-model is generated automatically from the ADL description of the wide variety of architectures, refer to [7].

## 5 Architecture Pipeline Verification

Based on the graph model presented in the previous section, specification of architecture pipelines written in an ADL can be validated. In this section, we describe some of the properties used in our framework for validating pipeline specification of the architecture. We also briefly describe the algorithms for verifying some of the properties used in our framework. The detailed algorithm for verifying each of these properties can be found in [7].

### 5.1 Connectedness Property

Each component must be connected to other component(s). As pipeline and data-transfer paths are connected regions of the architecture, this property holds if each component belongs to at least one pipeline or data-transfer path.

$$\forall v_{comp} \in V_S, (\exists G_{PP} \in \mathbf{G}_{PP}, s.t. v_{comp} \in G_{PP}) \\ \vee (\exists G_{DP} \in \mathbf{G}_{DP}, s.t. v_{comp} \in G_{DP}) \quad (14)$$

where  $\mathbf{G}_{PP}$  is a set of pipeline paths and  $\mathbf{G}_{DP}$  is a set of data-transfer paths.

The algorithm for applying this property on the graph model is simple. Prepare the list, L (say), of units, storages, ports, connections etc. from the ADL description. Traverse the graph, starting at the root node (e.g., Fetch), using pipeline and data-transfer paths. When a node (unit, port, storage, connection) is visited during graph traversal mark it in the list L. Finally, traverse the list L to determine the components that violate connectedness property (not marked).

### 5.2 False Pipeline Paths

According to the definition of pipeline paths, there may exist pipeline paths that are never activated by any operation. Such pipeline paths are said to be *false*. For example, let us use another example architecture shown in Figure 4 which executes two operations: ALU-shift (ALUS) and multiply-accumulate (MAC). This processor has units-to-opcodes mappings between ALU and ALUS, between SFT and ALUS, between MUL and MAC, and between ACC and MAC. Also,

there are units-to-opcodes mappings between each of  $\{IFD, RD1, RD2, WB\}$  and ALUS, and each of  $\{IFD, RD1, RD2, WB\}$  and MAC. This processor has four pipeline paths:  $\{IFD, RD1, ALU, RD2, SFT, WB\}$ ,  $\{IFD, RD1, MUL, RD2, ACC, WB\}$ ,  $\{IFD, RD1, ALU, RD2, ACC, WB\}$ , and  $\{IFD, RD1, MUL, RD2, SFT, WB\}$ . However, the last two pipeline paths cannot be activated by any operation. Therefore, they are false pipeline paths. Since these false pipeline paths may become false paths depending on the detailed structure of RD2, they should be detected at a higher level of abstraction to ease the later design phases. From the view point of SOC architecture DSE, we can view the false pipeline paths as indicating potential behaviors which are not explicitly defined in the behavior part of the ADL description. This means that further cost/performance/power optimization may be possible if we add new instructions that activate the false pipeline paths.

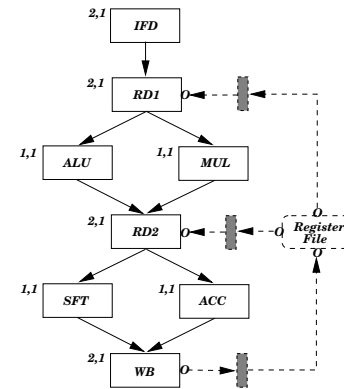

Figure 4. An example processor with false pipeline paths

Formally speaking, a pipeline path  $G_{PP}(V_{PP}, E_{PP})$  is false if intersection of opcodes supported by the units in the pipeline path is empty.

$$\bigcap_{v_{unit} \in V_{PP}} f_{unit-opcode}(v_{unit}) = \phi \quad (15)$$

To verify this property on the graph-model, the algorithm needs two operations viz., union and intersection of two sets containing opcodes. Each unit in the graph model has a list of supported opcodes (derived using unit-to-opcode mapping function). An outline of the algorithm follows. The root node (e.g. Fetch) sends a copy of its list of supported opcodes to all its children units (units connected to it via one pipeline edge). Each unit node performs the union of all the incoming lists and generate *incomingList*. Each unit node performs intersection between *incomingList* and its supported opcode list, and sends the result, *outgoingList*(say), to its children units. If the result of the intersection becomes NULL then that particular pipeline path is said to be false.

### 5.3 Completeness Property

All operations must be executable. A operation  $op$  is executable if there exists a pipeline path  $G_{PP}(V_{PP}, E_{PP})$  on which  $op$  is executable. A operation  $op$  is executable on a

pipeline path  $G_{PP}(V_{PP}, E_{PP})$  if both conditions (a) and (b) below hold.

- (a) All units in  $V_{PP}$  support the opcode of  $op$ . More formally, the following condition holds where  $v_{opc}$  is the opcode of the operation  $op$ .

$$\forall v_{unit} \in V_{PP}, v_{opc} \in f_{unit-opcode}(v_{unit}). \quad (16)$$

- (b) There is no conflicting partial ordering of operation arguments and unit ports. Let  $V$  be a set of argument nodes of  $op$ . There is no conflicting partial ordering of operation arguments and unit ports if, for any two nodes  $v_1, v_2 \in V$  such that  $(v_1, v_2) \in E_{exec}$ , all conditions below hold:

\* There exists a data-transfer path from a storage  $f_{arg-storage}(v_1)$  to a unit  $v_{u1}$  in  $V_{PP}$  through a port  $f_{arg-port}(v_1)$ .

\* There exists a data-transfer path from a unit  $v_{u2}$  in  $V_{PP}$  to a storage  $f_{arg-storage}(v_2)$  through a port  $f_{arg-port}(v_2)$ .

\*  $v_{u1}$  and  $v_{u2}$  are the same unit or there is a path consisting of pipeline edges from  $v_{u1}$  to  $v_{u2}$ .

For example, let us consider the ADD operation for the processor described in Figure 2 and Figure 3. To satisfy the condition (a), Fetch, Decode, ALU1, ALU2, and WriteBack units must have mappings to the ADD opcode. On the other hand, the condition (b) is satisfied because the structure has data-transfer paths from RegisterFile to Decode and from WriteBack to RegisterFile, and there is a pipeline path from Decode to WriteBack.

This algorithm has two parts. We can use the *outgoingList* for the final nodes (e.g., WriteBack, EMIF\_2 etc.) computed for false pipeline path property for the first part viz., to determine which opcodes are not supported by any pipeline path. We can perform union of all the *outgoingLists* for the final nodes of the graph. These are the opcodes supported by at least one of the pipeline paths. Now the opcodes which are not present in the resulting list violates the completeness property. To verify the second part of the property, the list of supported opcodes for each pipeline path is determined. This pipeline path should have read and write ports to specific storages (matching the number and type the operands for each opcode supported in that pipeline path) to make each of these operations executable.

#### 5.4 Well-formedness Property

The architecture must be well formed. To verify the validity of this property we need to verify several architectural properties, e.g., i) the number of operations processed per cycle by an unit can not be smaller than the total number of operations sent by its parents if the unit does not have any reservation station, ii) there should be a path from an execution unit supporting branch opcodes to PC/Fetch unit, iii) instruction template should match available pipeline bandwidth, iv) there

must be a path from load/store unit (e.g., MemCntrl) to main memory via storage components (e.g., caches), v) the address space used by the processor must be equal to the union of address spaces covered by memory subsystem (SRAM, cache hierarchies etc.).

#### 5.5 Finiteness Property

Termination of the pipeline must be guaranteed. The termination is guaranteed if all pipeline paths except false pipeline paths have finite length and all units on the pipeline paths have finite timing. The length of a pipeline path is defined as the number of stages required to reach the final nodes from the root node of the graph.

$$\exists K, s.t. \forall G_{PP} \in \mathbf{G}_{PP}, num\_stages(G_{PP}) < K \quad (17)$$

*num\_stages* is a function that, given a pipeline path, returns the number of stages (i.e. clock cycles) required to execute it. In the presence of cycles in the pipeline path, this function cannot be determined from the structural graph model alone. However, if there are no cycles in the pipeline paths, the termination property is satisfied if the number of nodes in  $V_S$  is finite, and each multi-cycle component has finite timing.

## 6 Experiments

In order to demonstrate the applicability and usefulness of our validation approach, we described a wide range of architectures using the EXPRESSION ADL: MIPS R10K, TI C6x, PowerPC, DLX [6], and ARM that represent RISC, DSP, VLIW, and Superscalar architectures. We generated the graph model of each of the architecture pipeline automatically from the ADL description. We implemented each property as a function which operates on this graph. Finally, we applied these properties on the graph model to verify that the specified architecture is well-formed. The complete validation of each architecture specification took less than a second on a 295 MHz Sun Ultra 60 with 1024M RAM.

As expected, we encountered two kinds of errors viz., incomplete specification errors and incorrect specification errors. An example of incomplete specification error we uncovered is that the opcode assignment is not done for the 5th stage of the multiplier pipeline in DLX. Similarly, an example of the incorrect specification error we found is that only load/store opcodes were mapped for the memory stage of the DLX architecture. Since all the opcodes pass through memory stage in DLX, it is necessary to map all the opcodes here.

During design space exploration (DSE) of the architectures we detected many incorrect specification errors. Here we briefly mention some of the errors captured using our approach.

We modified the MIPS R10K ADL description to include another load/store unit that supports only store operations. Well-formedness property was violated since there was a write connection from load/store unit to floating-point register file which will never be used.

We modified the PowerPC ADL description to have separate L2 cache for instruction and data. Validation determined that there are no paths from L2 instruction cache to main memory. The connection between L2 instruction cache and unified L3 cache is missing.

We modified the C6x data memory by adding two SRAM modules with the existing cache hierarchy. The property validation fails due to the fact that the address ranges specified in the SRAMs and cache hierarchy are not disjoint, moreover union of these address ranges does not cover the physical address space specified by the processor description.

We added a coprocessor pipeline in the MIPS R10K which supports vector integer multiplication. This path is reported as false pipeline path since this opcode was not added in all the units in the path correctly. It also violated completeness property since the read/write connections to integer register file was missing from the coprocessor pipeline.

In the R10K architecture we decided to use a coprocessor local memory instead of integer register file for reading operands. We removed the read connections to the integer register file and added local memory, DMA controller and connections to main memory. The connectedness property is violated for two ports in integer register file. These ports were used by the coprocessor earlier whose connections were deleted but not the ports.

We modified the PowerPC ADL description by reducing the instruction buffer size from 16 to 4. This generated the violation of well-formedness. The fetch unit fetches 8 instructions per cycle and decode unit decodes 3 instructions per cycle, hence there is a potential for instruction loss.

Table 1 summarizes the errors captured during design space exploration of architectures. Each column represents one architecture and each row represents one property. An entry in the table presents the number of violations of that property for the corresponding architecture<sup>1</sup>. The number in brackets next to each architecture represents the number of design space exploration done for that architecture. Each class of problem is counted only once. For example, the DLX error mentioned above where one of the unit has incorrect specification of the supported opcodes that led to false pipeline path for most of the opcodes, we count that error once instead of using the number of opcodes which violated the property. Our experiments have demonstrated the utility of our validation approach across a wide range of realistic architectures.

## 7 Summary

ADL-based codesign that supports automatic software toolkit generation is a promising approach to efficient design space exploration (DSE) of SOC architectures. The programmable portion of SOCs often includes pipelined processor, memory, and co-processor cores, whose pipeline struc-

<sup>1</sup>Note that the error numbers will change depending on the number of design space exploration and type of modifications done each time.

**Table 1. Summary of property violations**

	ARM (1)	DLX (2)	C6x (2)	R10K (3)	PowerPC (2)
Connectedness	0	0	1	2	1
False Pipeline Path	2	5	3	4	2
Completeness	1	2	3	3	2
Well-formedness	2	4	5	12	6
Finiteness	0	0	0	1	1

ture and behavior are described in the ADL. During architectural design space exploration, each instance of the architecture must be validated to ensure that it is well-formed. Moreover, validation of the specification is essential to ensure that the reference model is golden so that it can be used to uncover bugs in the design.

In this paper we presented a graph-based modeling of architectures that captures both the structure and the behavior of the processor, memory and co-processor pipelines. Based on the model, we proposed several properties that need to be satisfied to ensure that the architecture is well-formed. We applied these properties on the graph model of the MIPS R10K, TI C6x, ARM, DLX, and PowerPC architectures to demonstrate the usefulness of our approach. Our ongoing work targets the use of this ADL description as a golden reference model in architecture validation flow.

## References

- [1] A. Halambi et al. EXPRESSION: A language for architecture exploration through compiler/simulator retargetability. *DATE*, 1999.
- [2] G. Hadjiyiannis et al. ISDL: An instruction set description language for retargetability. In *Proc. DAC*, 1997.
- [3] P. Ho et al. Formal verification of pipeline control using controlled token nets and abstract interpretation. In *ICCAD*, 1998.
- [4] M. Freericks. The nML machine description formalism. Technical Report SM-IMP/DIST/08, TU Berlin., 1993.
- [5] J. Hauke and J. Hayes. Microprocessor design verification using reverse engineering. In *HLDVT*, 1999.
- [6] J. Hennessy and D. Patterson. *Computer Architecture: A quantitative approach*. Morgan Kaufmann Publishers Inc, CA, 1990.
- [7] P. Mishra et al. Architecture description language driven validation of processor, memory, and co-processor pipelines. TR UCI-ICS 01-52.
- [8] R. Ho et al. Architecture validation for processors. *ISCA*, 1995.
- [9] H. Tomiyama et al. Modeling and verification of processor pipelines in soc design exploration. *HLDVT*, 1999.
- [10] H. Tomiyama, T. Yoshino, and N. Dutt. Verification of in-order execution in pipelined processors. In *HLDVT*, 2000.
- [11] P. Mishra, N. Dutt, and A. Nicolau. Automatic Validation of Pipeline Specifications. In *HLDVT*, 2001.
- [12] <http://www.trimaran.org>. *The MDES User Manual*, 1997.
- [13] P. Mishra et al. Processor-memory co-exploration driven by an architectural description language. *VLSI Design 2001*.