



GLOBAL JOURNAL OF RESEARCHES IN ENGINEERING
ELECTRICAL AND ELECTRONICS ENGINEERING
Volume 13 Issue 6 Version 1.0 Year 2013
Type: Double Blind Peer Reviewed International Research Journal
Publisher: Global Journals Inc. (USA)
Online ISSN: 2249-4596 & Print ISSN: 0975-5861

Automatic Power Factor Improvement by using Microcontroller

By Md. Shohel Rana, Md. Naim Miah & Habibur Rahman

University of Engineering & Technology Rajshahi-6204, Bangladesh

Abstract - This paper represents the most effective automatic power factor improvement by using static capacitors which will be controlled by a Microcontroller with very low cost although many existing systems are present which are expensive and difficult to manufacture. In this study, many small rating capacitors are connected in parallel and a reference power factor is set as standard value into the microcontroller IC. Suitable number of static capacitors is automatically connected according to the instruction of the microcontroller to improve the power factor close to unity. Some tricks such as using resistors instead of potential transformer and using one of the most low cost microcontroller IC (ATmega8) which also reduce programming complexity that make it most economical system than any other controlling system.

Keywords : *microcontroller atmega8, current transformer, comparator, relay, capacitor, proteus 7.8, matlab.*

GJRE-F Classification : *FOR Code: 090699*



Strictly as per the compliance and regulations of :



Automatic Power Factor Improvement by Using Microcontroller

Md. Shohel Rana ^α, Md. Naim Miah ^σ & Habibur Rahman ^ρ

Abstract - This paper represents the most effective automatic power factor improvement by using static capacitors which will be controlled by a Microcontroller with very low cost although many existing systems are present which are expensive and difficult to manufacture. In this study, many small rating capacitors are connected in parallel and a reference power factor is set as standard value into the microcontroller IC. Suitable number of static capacitors is automatically connected according to the instruction of the microcontroller to improve the power factor close to unity. Some tricks such as using resistors instead of potential transformer and using one of the most low cost microcontroller IC (ATmega8) which also reduce programming complexity that make it most economical system than any other controlling system

Keywords : microcontroller atmega8, current transformer, comparator, relay, capacitor, proteus 7.8, matlab.

I. INTRODUCTION

Low power factor occurs large copper losses, poor voltage regulation and reduce handling capacity of the system. At low power factor KVA rating of the equipment has to be made more, making the equipment larger and expensive [1]. Power factor improvement is important because at high, medium and low power factor the current distortion levels tends to fall into low THDI $\leq 20\%$, medium ($20\% < \text{THDI} \leq 50\%$) and high (THDI $> 50\%$) respectively [2]. For the low power quality high financial loss per incident occurs that are given below.

Table I : Example of financial loss due to low power quality incident

Incident	Loss
Semiconductor production(*)	3800000€
Financial trade(*)	6000000€ per hour
Computer centre(*)	750000€
Telecommunication(*)	30000€ per minute
Steel industry(*)	350000€
Glass industry(*)	250000
Offshore platforms	250000-750000€ per day
Dredging/Land reclamation	50000-250000€ per day

The data labeled (*) in the table- I has been concluded after a European wide power quality survey undertaken by the European copper Institute in

Author α σ ρ : Department of EEE, Rajshahi University of Engineering & Technology Rajshahi-6204, Bangladesh.
E-mails : shohel.ieee@gmail.com, naim.tan@gmail.com, habibieeee@yahoo.com

2002. Other data is ABB experience data [3]. But low power factor can be improved by static capacitors [4], synchronous condenser, phase advancers [1]. In this paper power factor has been improved automatically by using microcontroller ATmega8 with static capacitors

II. POWER FACTOR IMPROVEMENT THEORY

The low power factor is mainly due to the fact that most of the power loads are inductive and therefore, take lagging currents. So capacitors are connected parallel with the load for leading power. It draws current I_c which leads the supply voltage by 90° . The resulting line current I' is the phasor sum of I and I_c and its angle of lag is ϕ_2 as shown in Fig 1(c). It is clear that ϕ_2 is less than ϕ_1 from phasor diagram. So that $\cos\phi_2$ is greater than $\cos\phi_1$. So that power factor of the load is improved [1].

This is shown in the following phasor diagram

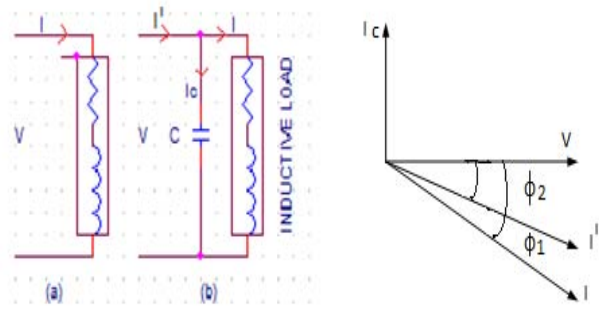

Figure 1 : Power factor improvement circuit and phasor diagram

III. CONTROL CONCEPT

In fig.2 voltage divider rule is used between two resistors for step down voltage. Here magnitudes are different but phase are same between input voltage and the voltage across R_2 . These wave shapes are shown in Fig.3 Why resistor is preferable to than PT? Suitable calculations are given below.

We know, $V = IR$ ($R_1 = 250K$, $R_2 = 10K$, Fig.1)
 $I = V/R$ if $R = \text{Kilo-ohm}$ ($R = R_1 + R_2$)

$I = \text{Voltage}/\text{kilo-ohm} = \text{Mili-amp}$
 $= 230\text{v}/260\text{k} = 0.8846\text{Mili-amp}$ (from fig2 (a))
Power loss $P = I^2 * R$
 $= (\text{Mili-amp})^2 * \text{kilo-ohm}$
 $= 0.2035\text{W}$

This value is so small and also be negligence. So resistor is preferable than potential transformer in the proposed plan because resistor is low cost than potential transformer.

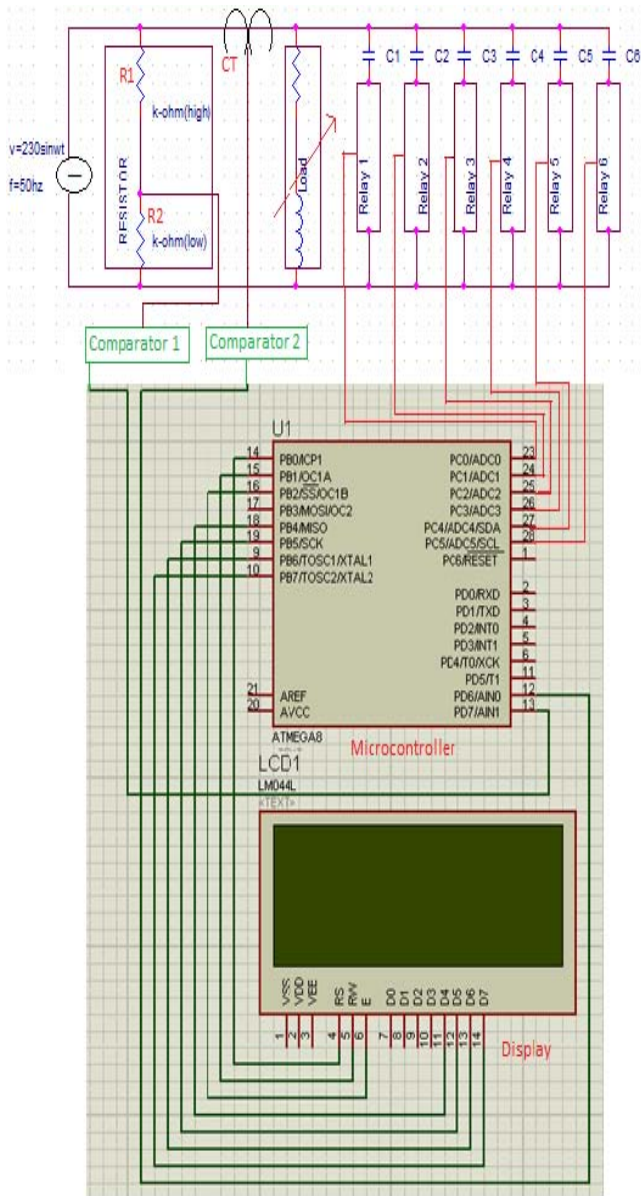

Figure 2 : Microcontroller based circuit diagram

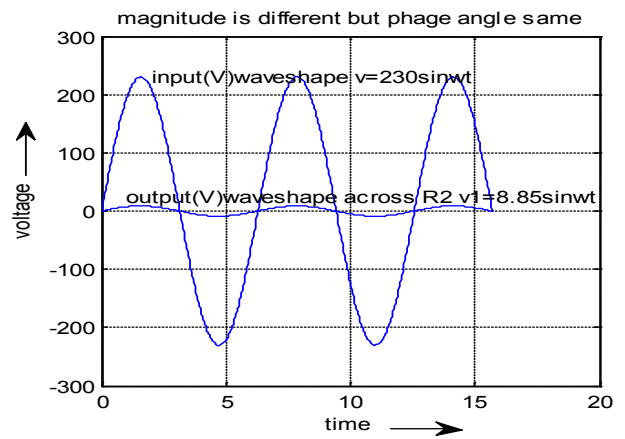

Figure 3 : Input (AC, 230v) and output (V) across R2

Two signals such as voltage signals from applying voltage divider rule between two resistors and current signals from CT are found. These signals are applying between two comparators shown in Fig.2.

IV. COMPARATOR OPERATION

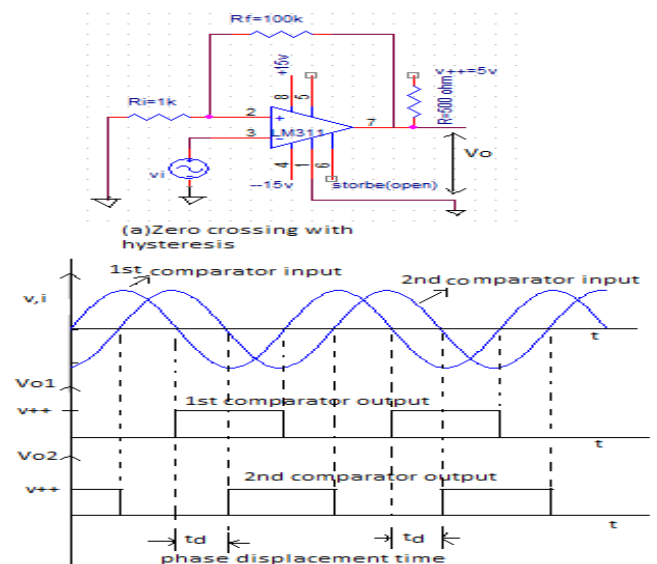

Figure 4 : Comparator and its input, output wave shape

The LM311 series is a monolithic, low input current voltage comparator. This device is also designed to operate at dual Or single supply voltage. LM311 also acts as a zero crossing detector [5]. When storbe is opened LM311 operates normally. The output voltage is at v_{++} for negative value of theinput voltage(v_i) and 0 for positive value of v_i shown in Fig.4.Phase displacement time(t_d) is also shown in Fig.4.This phase displacement time(t_d) between two comparators can easily be found by programming with microcontroller. If time (t_d) is very small, good PF will be found. If (t_d) is high bad PF will be found. So capacitors are connected across the load to reduce the phase displacement time.

V. MICROCONTROLLER OPERATION

Let, $CLK_{CPU} = 2\text{MHz}$
 Pre-scale = 8
 $CLK_{TIMER} = (2\text{MHz}/8) = 250\text{KHz}$
 $T_{TIMER} = (1/250\text{KHz}) = 4\mu\text{s}$
 So 4 μs is needed to count pulse 1.
 10ms is needed to count pulse = $(10\text{ms} * 1) / 4\mu\text{s}$
 = 2500
 So maximum pulse value = 2500

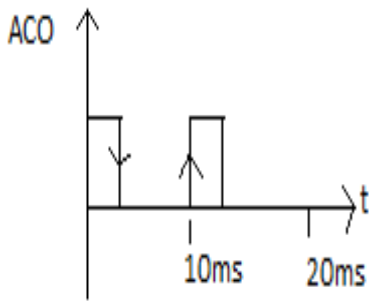

Figure 5 : Analog comparator output of microcontroller

Count the timer value from one falling edge to next rising edge in Fig.5. Now subtract this value from maximum pulses value. This will be the timer value of displacement between voltage and current signal.

Now from the main signal we get,

10ms is equal to displacement = 3.1416 radian
 1 μs is equal to displacement = $(3.1416/10000)$ radian
 = 0.00031416 radian.
 Now Pulse width, $t = 4\mu\text{s} * (2500 - \text{clock number})$
 Theta, $\alpha = 0.00031416 * 4 * (2500 - \text{clock number})$
 = $0.00125664 * (2500 - \text{clock number})$ radian

Here, clock number is a variable depends on signal. So, Power factor = $\text{Cos}\alpha$ can easily be calculated.

Also applying a condition in the programming, if Power factor less than 0.96 then all output ports of the microcontroller will be serially high and connected the capacitors parallel to the load by relay. If power factor is greater than 0.98 then all output ports of the microcontroller will be serially low and disconnected the capacitors parallel to the load by relay. Microcontroller output ports become low or high automatically to keep the power factor from 0.96-0.98 range.

The program flow chart is given in Fig.6.

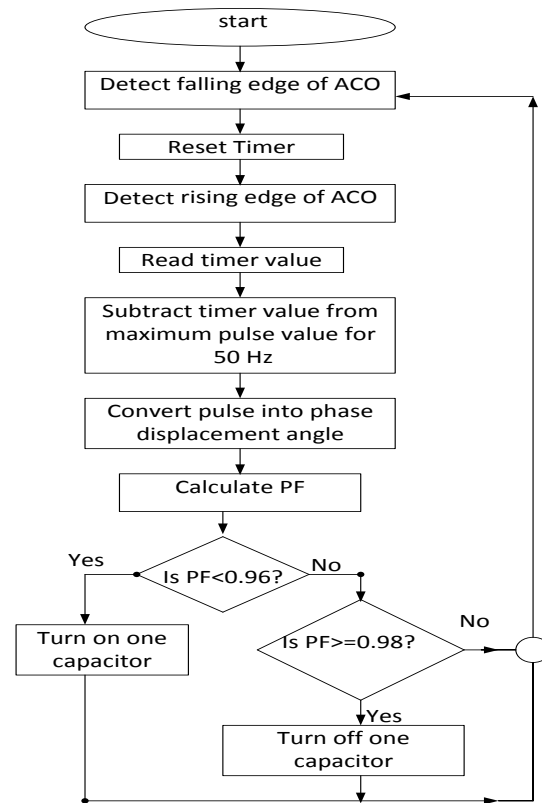
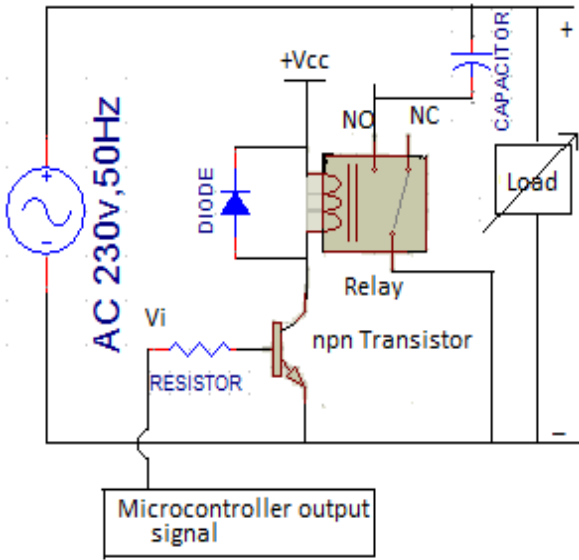

Figure 6 : Flow chart of the microcontroller program

VI. OPERATION OF RELAY

If microcontroller output is high then transistors turns on, establishing sufficient current through the coil of the electromagnet to close the relay and capacitor will be connected parallel to the load. Problem can now develop when the microcontroller signal is removed from the base to turn off the transistor and de-energize the relay. Trying to change the current through an inductive element too quickly may result in an inductive kick that could damage surrounding elements or the system itself. This destructive action can be subdued by placing a diode across the coils shown in Fig.6. During the on state of transistor, the diode is back-biased; it sits like an open circuit and doesn't affect a thing. However, when the transistor turns off the voltage across the coil will reverse and will forward-bias the diode, placing the diode in it's on state. The current through the inductor established during the on state of the transistor can then continue to flow through the diode, eliminating the sever change in current level. The diode must have a current rating to match the current through the inductor and the transistor when in the on state. Thus the capacitor is connected parallel across the load by relay without any hazard [6].



VII. SIMULATION OF POWER FACTOR

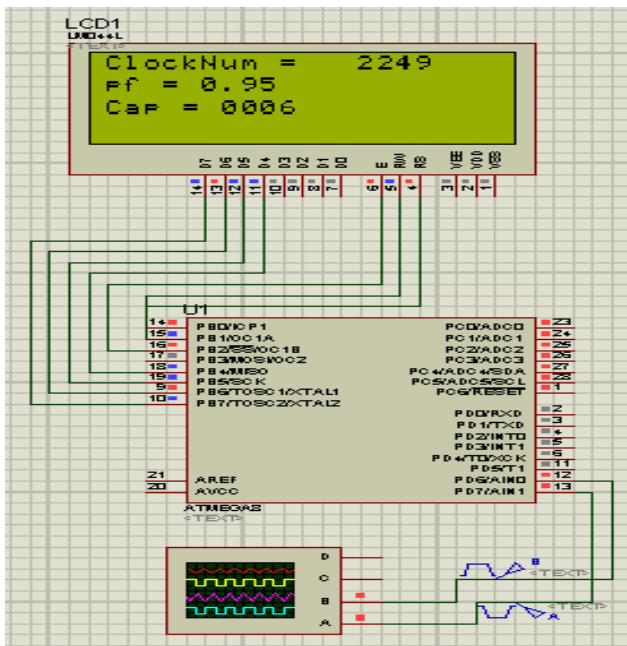

Figure 8 : Simulation Mode1

From simulation clock value is equal to 2249 for the signal of pulse generator (B) in Fig.10 and pulse generator (A) shown in Fig.9. According to the microcontroller operation power factor will be $=\text{Cos}((0.00125664 * (2500-2249)))=0.95$ and this value is found in simulation display shown in Fig.8

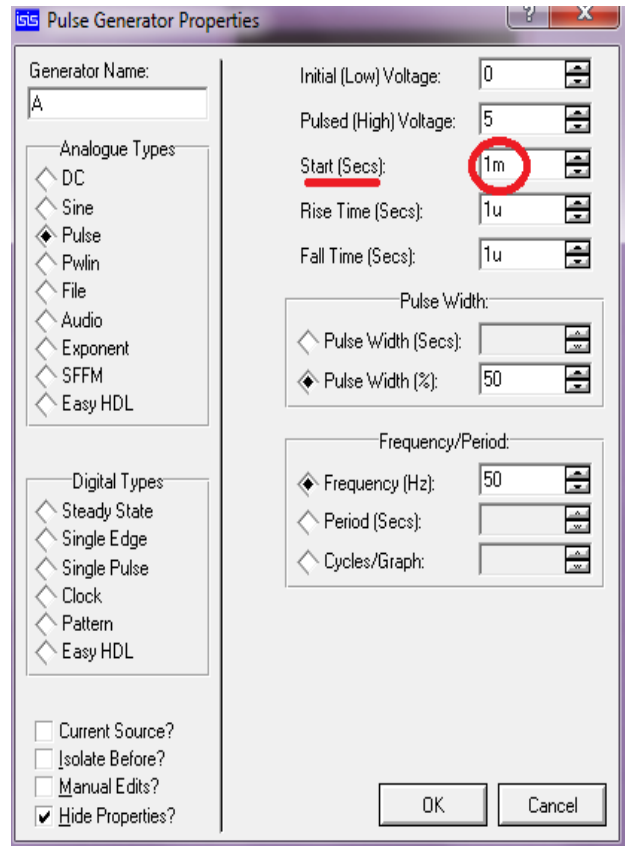

Figure 9 : Pulse generator(A) in simulation mode1

Pulse generator (A) and pulse generator (B) are different in start time. Pulse generator (A) start time 1 milli-sec in Fig.9 and pulse generator (B) start time 0 sec shown in Fig.10.

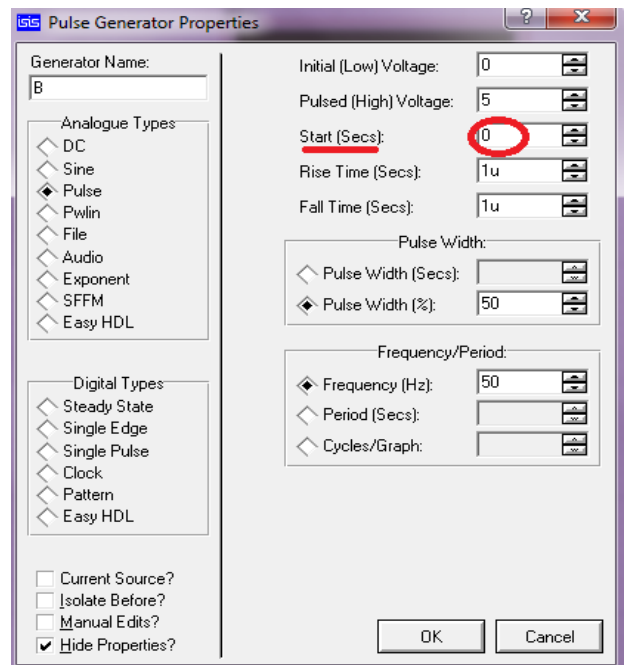

Figure 10 : Pulse generator (B) in simulation mode1

If pulse generator (B) remains constant and pulse generator (A) start time changes, then power factor will also be changed. Also applying a condition in the programming if power factor <0.96, then output PORTC pin(23to28) of microcontroller will become high serially shown in Fig.7 with red dot until power factor become 0.96. Here also applying a condition $PF > 0.98$, PORTC will become zero.

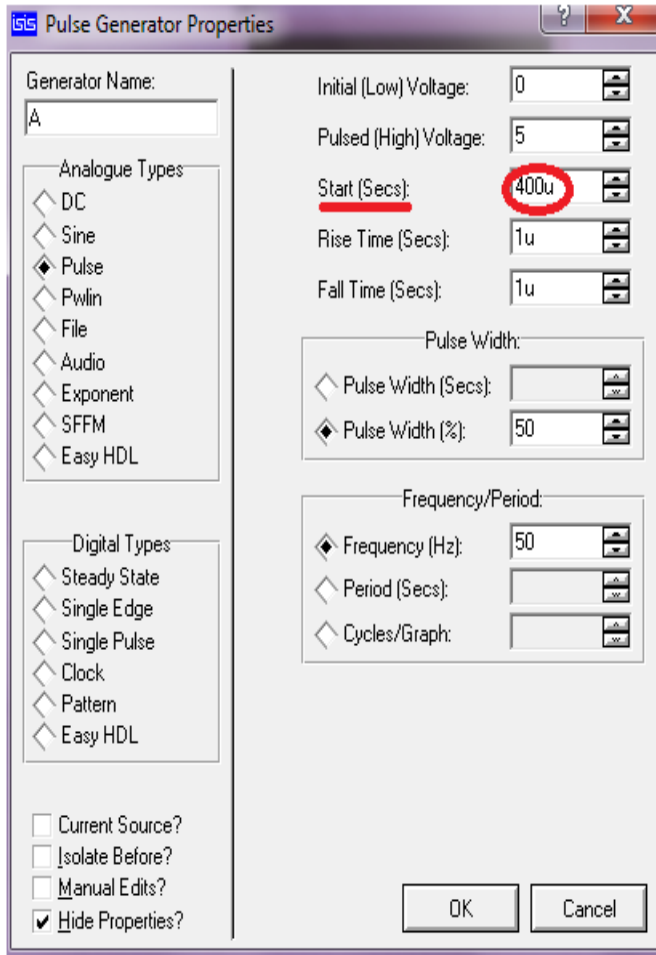

Figure 11 : Pulse generator(A) in simulation mode2

One by one until PF become 0.98 shown in Fig.12 with blue dot. So PF remains 0.96 to 0.98 range. When pulse generator (A) start time (400us) in Fig.11 and pulse generator (B) remain same in Fig.10 power factor changes 0.99 shown in Fig.12.

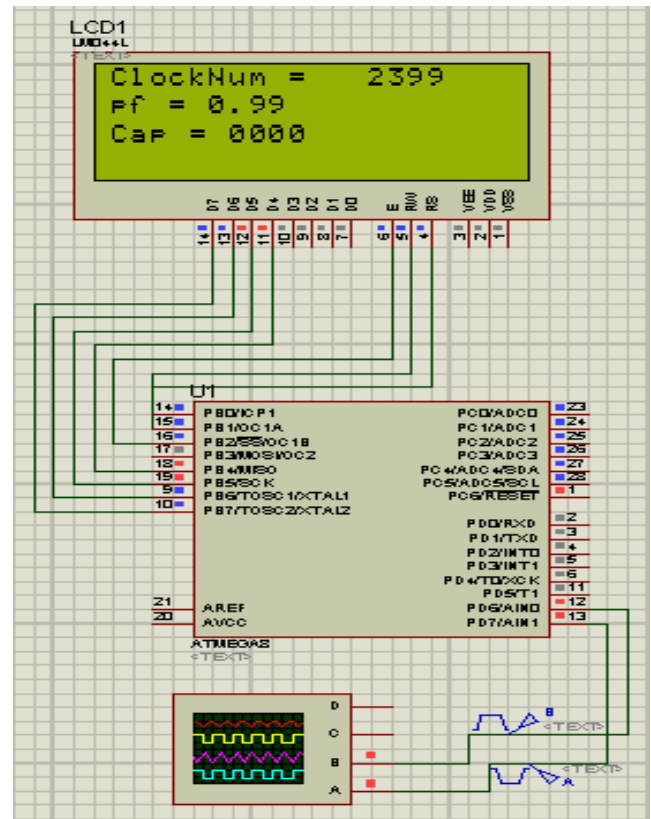

Figure 12 : Simulation Mode2

In simulation microcontroller output PORTC cannot impact on the pulse generator (A) at the same time for the lack of simulation process. But in practical design pulse generator(B) will act as comparator1 output that is responsible for the input voltage of Fig.2. Pulse generator(A) will act as comparator2 output that is responsible for the output of CT and the output of CT depends on varying inductive load. So applying a system between PORTC and pulse generator (A) which controls pulse generator (A) and pulse generator (A) controls PORTC and PORTC controls the system. Thus a cyclic order control is present in the system. If power factor is low than 0.96 according to the programming PORTC will high and relay will connect the capacitors which reduce the start time of pulse generator (A). So power factor will be improved by connecting suitable number of capacitors until it becomes 0.96. If power factor is greater than 0.98 relay will disconnect the capacitors one by one to sustain the power factor from 0.96 to 0.98 range. By changing the starting time period of pulse generator (A), the power factor correction result has been summarized in Table-II.

VIII. SIMULATION RESULTS & DATA TABLE

Table II : Summary result of power factor of different phase displacement time (t_d)

Pulse gen. (A) Start time	Pulse gen. (B) Start time	t_d (ms)	Clock No.	PF	PORTC Output	Cap. connection serially
3ms	0	3	1749	.58	High	On
2ms	0	2	1999	.8	High	On
1.5ms	0	1.5	2124	.89	High	On
1ms	0	1	2249	.95	High	On
800 μ s	0	0.8	2299	.96	NC	NC
600 μ s	0	0.6	2349	.98	NC	NC
400 μ s	0	0.4	2399	.99	Low	Off

It is seen from simulation in Table-2 that phase displacement time t_d between pulse generator (A) and pulse generator (B) increases, then PF becomes low. Phase displacement time (t_d) is low, PF becomes high. So phase displacement time (t_d) is inversely proportional to PF. This is shown in Fig.13 graphically.

This phase displacement time (t_d) is increased due to increase of inductive load. So capacitors are connected.

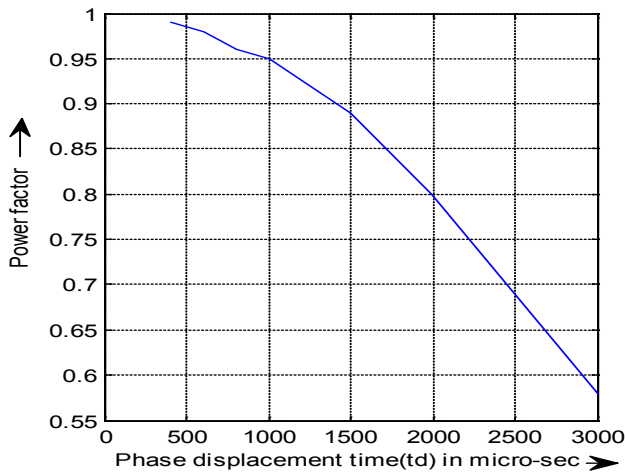

Figure 13 : Phase displacement time verses power factor

Across the inductive load automatically by using microcontroller to reduce the phase displacement time (t_d) until power factor will become 0.96-0.98 range. So power factor will be improved in a certain level.

IX. CONCLUSION

This paper shows an efficient technique to improve the power factor of a power system by an economical way. Static capacitors are invariably used for power factor improvement in factories or distribution line. But this paper presents a system that uses capacitors only when power factor is low otherwise they are cut off from line. Thus it not only improves the power

factor but also increases the life time of static capacitors. The power factor of any distribution line can also be improved easily by low cost small rating capacitor. This system with static capacitor can improve the power factor of any distribution line from load side. As, if this static capacitor will apply in the high voltage transmission line then it's rating will be unexpectedly large which will be uneconomical & inefficient. So a variable speed synchronous condenser can be used in any high voltage transmission line to improve power factor & the speed of synchronous condenser can be controlled by microcontroller or any controlled device.

REFERENCES REFERENCES REFERENCIAS

1. V.K Metha and RohitMehata, "Principles of power system", S. Chand & Company Ltd, Ramnagar, Newdelhi-110055, 4th Edition, Chapter, 6.
2. W.Mack Grady and Robert J. Gilleskie , "Harmonics and how they relate to power factor", Proc.Of the EPRI power quality issues & opportunities conference (PQA'93), San Diego ,CA, November 1993.
3. Dr. Kurt Schipman and Dr. Francois Delince , "The importance of good power quality", ABB power quality Belgium.
4. KhinTrarTrarSoe, "Design and economics of reactive power control in distribution substation", World academy of science, engineering and technology 24 2008.
5. Robert.F.Coughlin, Frederick.F.Driscoll, "Operational amplifiers and linear integrated circuits", 6th Edition, chapter, 4.
6. Robert L. Boylestad, Louis Nashelsky, "Electronic devices and circuit theory", 8th Edition, chapter.