

# Automotive Radar—From First Efforts to Future Systems

CHRISTIAN WALDSCHMIDT <sup>1</sup> (Senior Member, IEEE), JUERGEN HASCH <sup>2</sup> (Senior Member, IEEE),  
AND WOLFGANG MENZEL <sup>1</sup> (Life Fellow, IEEE)

(Invited Paper)

<sup>1</sup>University of Ulm, 89081 Ulm, Germany

<sup>2</sup>Robert Bosch GmbH, Corporate Sector Research and Advance Engineering, 70465 Stuttgart, Germany

CORRESPONDING AUTHOR: CHRISTIAN WALDSCHMIDT (e-mail: christian.waldschmidt@uni-ulm.de).

---

**ABSTRACT** Although the beginning of research on automotive radar sensors goes back to the 1960s, automotive radar has remained one of the main drivers of innovation in millimeter wave technology over the past two decades. Today, millions of sensors are produced each year, which was made possible by inexpensive and mature millimeter wave technology. The technology maturity, in turn, enables research to be carried out on systems that are considerably more complex and powerful than was possible just a few years ago. The focus of research has thus shifted from purely hardware-oriented and device-level topics to sophisticated millimeter wave systems and RF signal processing topics. This opens up new research topics such as digital modulation schemes, radar networks, radar imaging, and machine learning. In this review paper, we sketch the path from the very beginning through the state of the art with sophisticated multiple-input multiple-output (MIMO) antenna arrays and mature assembly and interconnect concepts to today's key research topics of automotive radar.

**INDEX TERMS** ADAS, automotive radar, chirp sequence modulation, compressed sensing, digital modulation, FMCW, grid map, interference, millimeter wave radar, MIMO, MMIC, OFDM, PMCW, radar networks, radar SOC, SAR.

---

## I. INTRODUCTION

Safety for drivers, passengers, and any other road users has become of major interest during the last decades. To this end, radar sensors were considered as essential means to detect other vehicles, pedestrians, or bicyclists as well as the road environment. Radar is insensitive to bad light and severe weather conditions and can directly measure distance, radial velocity, and with a suitable antenna system also the angle of remote objects. At the beginning, the focus was on distance warning and crash avoidance, but with increasing maturity and complexity, functions included adaptive cruise control (ACC), automatic emergency brake (AEB), blind spot detection (BSD), or lane change assist (LCA). Nowadays, safety functions protecting passengers and vulnerable road users play a major role.

With increasing performance more than single reflections from a remote object can be detected and images of the

whole environment can nowadays be obtained by the radar sensors. With the availability of highly integrated monolithic microwave integrated circuits (MMIC)s in silicon technology, novel packaging approaches, planar antennas, and increasingly powerful signal processing, radar based systems can be mass produced at continuously decreasing cost and migrated from premium to compact car class during recent years. This development was also fostered by the ratings of EuroNCAP [1] including protection of vulnerable road users. Digital beamforming (DBF) and multiple-input multiple-output (MIMO) concepts already transferred analog functions to the digital domain with major improvements in lateral detection. Advanced data processing will allow further system enhancements in terms of flexibility, unambiguousness, resolution, and target classification.

While in the past automotive radars were operated in the 24 GHz band mostly for short range applications and in the



**FIGURE 1.** Bistatic 35 GHz pulse radar mounted in the front of a passenger car and view on one of the two parabolic antennas [26]. Left photograph: Telefunken, courtesy of H.H. Meinel; right photograph by W. Menzel.

76–77 GHz range for longer range or more demanding applications, most of the newly developed sensors today operate in the frequency band of 76–81 GHz [2], [3]. Research on higher frequency bands above 100 GHz is ongoing [4], however, the vehicle integration and technological challenges especially regarding semiconductor technology performance are still open.

Section II of this paper will give a review of early automotive radar sensors, Section III describes the state of the art, and Section IV addresses current research topics.

## II. REVIEW ON AUTOMOTIVE RADAR

The first ideas and investigations for automotive radar came up in the 1960 s, continuing in the 1970 s by Bendix, Info Systems Inc., RCA, and General Motors, partly supported by the U.S. Department of transportation [5]–[15], followed by the Japanese companies Mitsubishi and Nissan [16], [17].

In Germany, the companies SEL, VDO, and AEG Telefunken started related work supported by the German Ministry of Science and Technology [18]–[22]. Those times' intentions were precollision obstacle detection and/or emergency braking. Work was based on available technologies and devices, typically GUNN elements for the transmitter and (Schottky) diodes for the receiver/downconverter. Transistors with sufficiently high cut-off frequencies came up only later [23]. Planar integrated circuits, e.g. microstrip, and integrated antennas were introduced only in the lower frequency range (10 GHz, X-band; 15 GHz, Ku-band); with higher frequencies, waveguide-based circuits and antennas were employed. The radar principle considered at the beginning [5], [6], [8]–[11], was based on a two-frequency transmission with phase evaluation for distance measurement [24] followed by pulse and frequency modulated continuous wave (FMCW) principles. Radar frequencies first were around 10 GHz or 16 GHz, resulting in reasonably large antenna areas for the required beamwidths. Following this, 24 GHz (ISM band), 35 GHz (low atmospheric attenuation), 60 GHz (mostly in Japan, e.g. [25]), and finally 76 GHz led to a reduced antenna aperture size. An early example of a bistatic pulse radar at 35 GHz is shown in Fig. 1 [19]. Two parabolic dishes were placed at the front side of a passenger car; for the test system the antennas were milled from massive aluminum. The transmitter was based on a GUNN oscillator, for the downconversion of the received signal, a Schottky diode on a small quartz substrate was fixed in a waveguide mount.



**FIGURE 2.** 24 GHz VORAD radar mounted at the front side of a Greyhound bus. Photograph by W. Menzel.

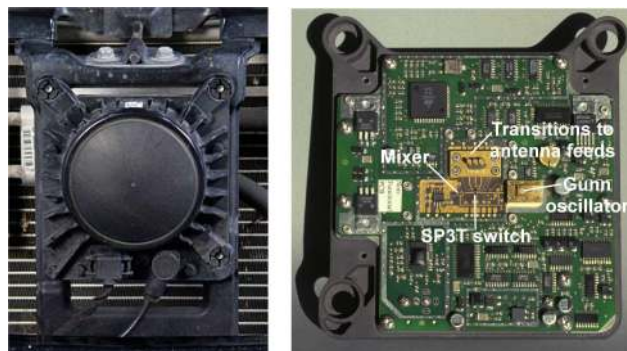

**FIGURE 3.** Front and back side of first commercial automotive ARS 100 radar by Mercedes Benz. Photographs by W. Menzel.

Distance measurement and collision warning worked well, but of course, technology was not yet mature enough.

In the following years, technology of RF devices and circuits as well as signal processing circuits improved considerably. The 24 GHz ISM band became a preferred frequency for low-cost sensors, and the 76–77 GHz band was assigned worldwide for automotive radar. A first commercial radar was the 24 GHz sensor from VORAD mounted to many buses and trucks in the USA, Fig. 2 [27]. It used a switched, multiple-frequency modulation, a GUNN oscillator with 0.5 mW power, and planar antennas. Also a 77 GHz version was developed later on. Accidents could be reduced considerably, but the use of the sensor had to be stopped by intervention of the driver union—the drivers felt controlled too much by the system.

The first commercial 76 GHz automotive radar for passenger cars was introduced 1998/99 by Mercedes Benz (Fig. 3). It was built by Macom in the USA [28], firstly based on a GUNN oscillator and a microstrip receiver circuit. Later on, GaAs MMICs [29] were included. The antenna was a folded parabolic reflector (see [28], [30]) with three switchable beams (three feeds selected by a SP3T switch). Advanced versions of this sensor were then developed by the German company Continental, including GaAs MMICs. In a first step, the folded parabolic reflector was replaced by a modified folded reflectarray antenna [31], a further antenna concept was based on an advanced scanning system (Fig. 4).

The entire arrangement consists of a dielectric waveguide close to a rotating drum with ridges and a folded reflectarray

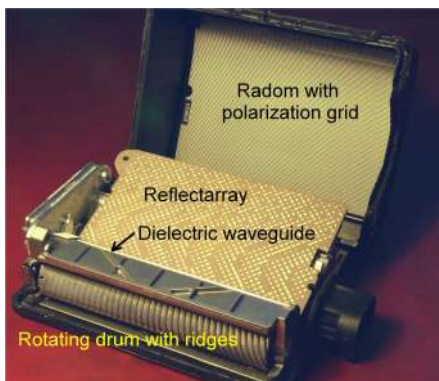

**FIGURE 4.** Opened ARS3 sensor from CONTINENTAL. Photograph by W. Menzel.



**FIGURE 5.** Exploded view on the Bosch LRR3 sensor and details of the planar antenna elements feeding the lens. Sensor photograph provided by Bosch.

consisting of a polarizing grid integrated with a radome, and a focusing reflectarray. While the drum rotates, the ridges with varying distances provide periodic discontinuities to the dielectric waveguide, thus radiation occurs with varying angles in the horizontal direction. In the elevation, focusing is done by the folded reflectarray structure. This antenna can scan over  $\pm 12$  degrees and provides high gain both in transmit and receive. As a consequence, the sensor with this antenna was considered as the most sensitive one, but the fabrication effort was high.

With respect to MMIC integration density and cost, the development of SiGe MMICs with several radar channels integrated on a single chip was an important step [32]. A first radar sensor based on such a chip was the Bosch LRR3 sensor (Fig. 5). As antenna, a lens configuration [33] was chosen, fed by four separated microstrip patch feeds, resulting in four beams. Each feed antenna was connected to one of

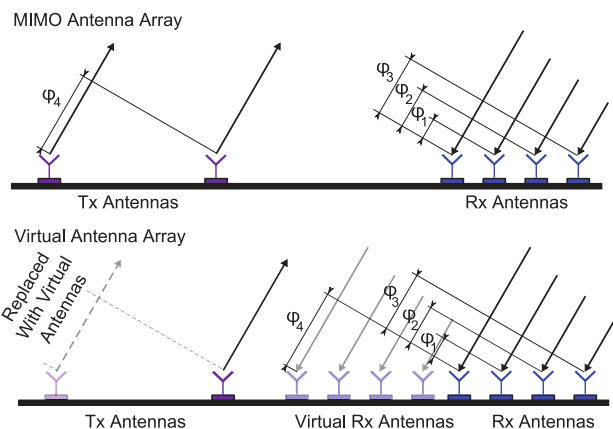

**FIGURE 6.** A diagram showing the principle of MIMO radar and virtual apertures [40].

four channels of a SiGe MMIC. In the first design, the MMIC had to be connected to the RF board by wire bonding; later on, a novel packaging and interconnect technology called embedded wafer level ball grid array (eWLB) [34] led to connections via a ball grid array, hence no special wire bonding equipment was necessary anymore.

With the easy and relatively low-cost availability of several radar channels on one chip, a new system and antenna configuration became possible with one or more transmit and multiple receive channels, each connected to one antenna element. Beamforming is done only after reception, downconversion, and analog-digital conversion (ADC) in the digital domain (digital beamforming). With several transmit channels, MIMO concepts can be introduced (although, at the beginning, the term MIMO was not used) [35]–[38]. With proper arrangements of transmitters and receivers, a cross range resolution better than according to the physical antenna aperture can be realized [39]. According to antenna theory, the angular distribution of the radiated fields (radiation pattern) of an antenna is proportional to the Fourier transform of its excitation distribution in the respective plane. On the other hand, the signal transmitted from one subarray and received by another one is proportional to the multiplication of the radiation patterns of these two arrays. Consequently, this product can also be derived from an excitation distribution formed by the convolution of the two individual excitations, see Fig. 6 (valid also for 2D-arrangements). An early example is the sensor by Toyota shown in Fig. 7. This concept now is pursued by many companies, see also Fig. 9 in Section III.

### III. STATE OF THE ART

Since the introduction of the first generation of automotive radar sensors around the year 2000, several new generations have been introduced by an increasing number of established companies like Aptiv, Bosch, Conti, Denso, Hella, Mando, Valeo, or Veoneer. Also startups like Arbe [41] or Uhnder [42] have emerged, presenting their own approach to a high-performance automotive radar.

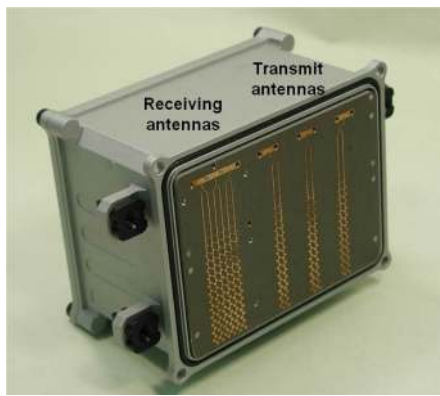

**FIGURE 7.** Automotive sensor with three transmit and three receive antenna arrays in microstrip technology (courtesy of Toyota Labs), antenna radome removed.

**TABLE 1.** Radar Performance Parameters

Parameter		Value
Frequency	band	76–77 GHz
Distance	max.	210 m
	accuracy	0.1 m
	resolution	0.2 m
Velocity	accuracy	0.05 m/s
	resolution	0.1 m/s
Field of view	horizontal	±60 deg
	vertical	±15 deg
Hor. angle	accuracy	0.1 deg
	resolution	3.0 deg
Vert. angle	accuracy	0.2 deg
	resolution	6.0 deg

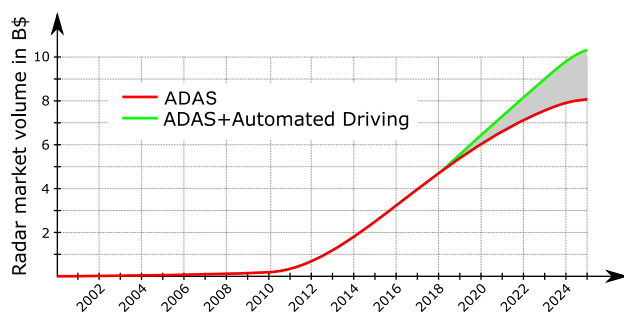

**FIGURE 8.** Automotive radar market development for ADAS and AD functions with projection up to 2025 based on [43] and earlier market numbers.

requirement for active safety systems mandated by new car assessment program (NCAP).

Ten years later, another market trend towards high-performance radar sensors for advanced driver assistance system (ADAS) with partial automation and automated driving (AD) with full automation is emerging. Currently, it is still too early to tell when this trend will fully materialize. This differentiation of functionality leads to different sensor requirements. ADAS sensors need to fulfill a number of well defined functions and are extremely cost sensitive. Sensors addressing AD need to provide the best available performance in terms of distance, velocity, and angle information possible with much less emphasis on cost, size, and production volume.

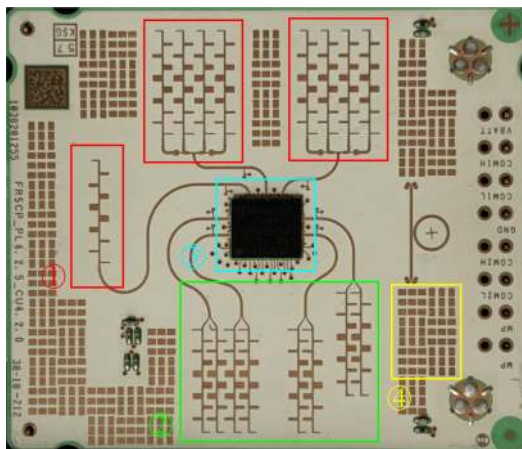

**FIGURE 9.** Bosch 5<sup>th</sup> generation radar PCB with ① transmit antennas, ② receive antennas, ③ frontend MMIC, ④ reflection reduction structures.

The rapid development of new radar sensor generations is driven by a strong market demand as shown in Fig. 8, mainly for advanced driver assistance systems (ADAS), with the market volume starting slowly until 2010 and then massively taking off. This development was fueled by the migration of established driver assistance functions from high class into middle class vehicles, and then further accelerated by the

**A. ADAS SENSOR EXAMPLE**

An example for the current generation of radar sensors for the ADAS market is the Bosch Gen 5 front radar [44] with its RF frequency printed circuit board (PCB) depicted in Fig. 9. It operates in the 76–77 GHz frequency band and uses three transmit and four receive antennas. Two of the transmit antennas are realized with higher gain compared to the receive antennas, to achieve a front-looking radar with a distance range of more than 200 m with a horizontal field of view of 120deg. Together with the receive antennas they realize a MIMO antenna array that allows obtaining horizontal and vertical angle information with high accuracy and resolution.

The surface-mounted frontend MMIC in the center of the PCB is manufactured in a silicon germanium (SiGe) bipolar CMOS (BiCMOS) technology and provides three transmit and four receive channels, a 76–77 GHz VCO combined with a frequency sweep phase-locked loop (PLL), and the receive baseband including ADCs. To reduce reflections from the PCB surface, copper structures are placed on the free areas of the PCB [45].

Table 1 gives the key technical parameters of the radar sensor. Compared to its predecessor described in [46], this reflects a significantly improved performance especially in velocity and angle resolution.

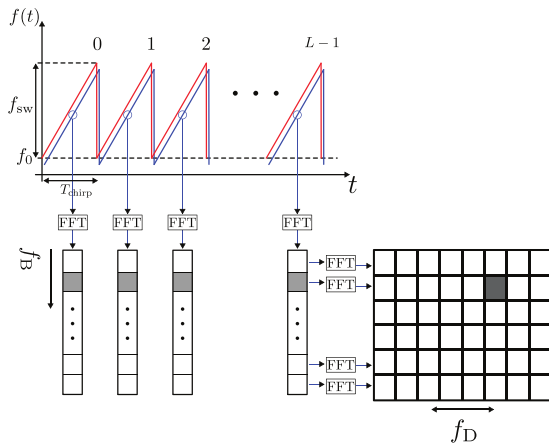

FIGURE 10. Chirp sequence modulation principle [47].

### B. MODULATION AND SIGNAL PROCESSING

In order to improve angle and velocity measurement performance, a modulation scheme is required that allows measuring the velocity unambiguously with high accuracy and allows transmit antenna switching to enable MIMO operation for improved angle estimation. One well-known solution is the fast chirp FMCW modulation described in [47].

Figure 10 shows the principle of chirp modulation with a sequence of transmit chirps (red) being sent out and received back (blue). The receive signal of all chirps combined is 2D-FFT processed to generate a range-velocity matrix. This allows to locate and separate targets in range and velocity within the given resolution. Further processing of several measurements in time or from multiple transmit and receive channels allows extracting  $\mu$ Doppler movements and angle information, respectively.  $\mu$ Doppler describes the time-dependent variation of the radial velocity due to vibrations, rotation or small movements.

With the growing number of transmit antennas used in a MIMO scheme, an important limitation becomes apparent. The maximum unambiguous radial velocity gets reduced by the number of transmit antennas, if as usual time multiplexing between the transmitters is applied. This effect can be counteracted by reducing the chirp time, however the practical achievable linearity of the frequency ramp generation, the increased sampling speed requirements of the analog-to-digital converter (ADC), and the flight time of the radar signal from the sensor to the remote target and back limit the minimum practical value of  $T_{\text{chirp}}$ . Different approaches to overcome this limitation have been proposed, like frequency division multiplex (FDM) [48], [49] or code division multiplex (CDM) [50], [51] of the transmit signals. Another approach is the application of digital modulation schemes, this will be addressed in Section IV.

### C. TECHNOLOGY

As described in Section II, the first millimeter wave radar sensors were based on GaAs technology [52], either as discrete components or integrated circuits. As silicon-based Silicon

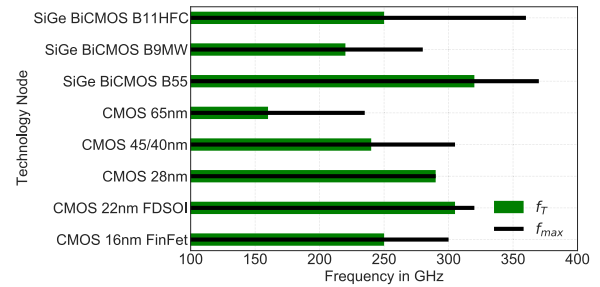

FIGURE 11. Comparison of transistor speed for different silicon technologies [53].

Germanium (SiGe) technology became competitive in terms of speed and cost, the transition to silicon started in 2010. This enabled higher integration densities and allowed to add more functionality at lower cost and a further move into mass production. For the first time, a complete transceiver including some digital components could be realized. This also significantly simplified the realization of the millimeter wave part of the radar sensor itself.

Following the example of the mobile phone industry, the next seemingly inevitable technology transition is the move to CMOS. Today's CMOS technologies offer an extremely high integration density for digital circuits and can provide good RF performance. One indication of the feasibility for CMOS technology in an automotive radar at 77 GHz is transistor speed. Figure 11 shows a comparison of transistor  $f_T$  and  $f_{max}$  for a number of state-of-the-art CMOS and SiGe-BiCMOS technologies. It can be seen, that several CMOS processes in the 45 nm down to 22 nm nodes exhibit excellent transistor speeds, nearly on-par with modern SiGe-BiCMOS technology. Sufficient performance of other key parameters like noise figure and output power has also been verified for CMOS technology in the examples given below.

The feasibility of 77 GHz radar transceivers in CMOS technology has been demonstrated in a variety of papers over the last years, with [54] being one of the first, and [55] being a more recent publication describing a multi-channel transceiver.

A move to CMOS enables a further significant increase in integration density and the transition from an analog-centric radar transceiver to a radar system on chip (SoC). It typically integrates the millimeter wave frontend, analog baseband, and digital processing on a single die. Figure 12 shows the block diagram of a test SoC realized in 22 nm CMOS FDSOI technology [56] with two transmitters, two receivers, the complete analog baseband, ADCs, and digital signal processing accelerator components like fast Fourier transform (FFT) and constant false alarm rate (CFAR). Microcontroller cores, memory, or machine learning engines can potentially also be integrated, enabling standalone operation with minimal additional outside components. An already available commercial example of an SoC in 45 nm CMOS technology is described in [57].

Surface-mount packages like the eWLB shown in Fig. 13 have proven to be low-cost and reliable, while providing

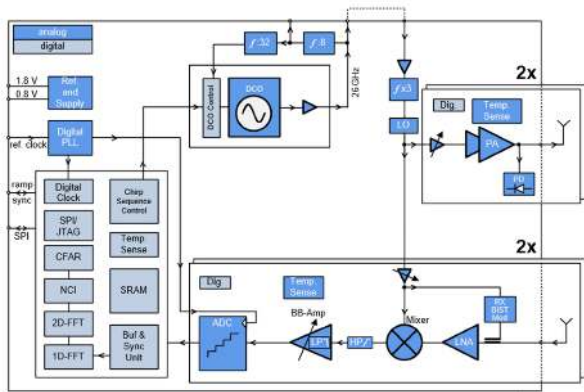

**FIGURE 12.** Radar system on chip (SoC) example showing Bosch evaluation chip at 77 GHz [56].

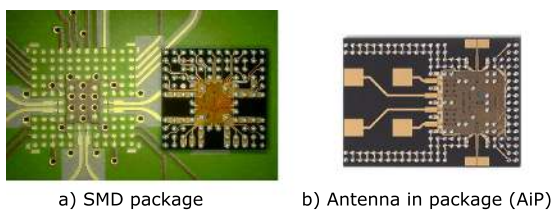

**FIGURE 13.** Surface mount packages for millimeter wave radar transceivers.

good RF performance of the chip-to-PCB transition up to 80 GHz [58]. The chip is placed into a mold compound that forms the package, with the contacts of the chip facing to the surface. On the surface a redistribution layer is formed, that allows connecting the pads of the chip to solder balls placed in a grid on the package.

Similar alternatives like interposer-based flip-chip chip scale package (FC-CSP) have been successfully introduced [59]. Extending the SMD package approach from single layer to multiple redistribution layers allows high-channel count radars like [60]. Another extension of the capabilities of such a package is replacing the RF transition by antenna elements to form an antenna in package (AiP) [61], completely removing the need for millimeter wave structures on the PCB. This approach is useful mostly for short-range application like [62], where limited antenna gain and spacing between multiple antennas is restricted by the available package area.

**D. INTERFERENCE**

The basic premise of radar is reliable detection even under changing environmental conditions. With the strongly increasing number of vehicles equipped with up to twelve radars, the environment becomes crowded with millimeter wave signals. As there are currently no set rules for coexistence in the 76–77 GHz frequency band, interference between different radar sensors becomes more likely.

Figure 14a) shows the scenario for the simulation of a 500 m long dense highway with six lanes, where vehicles equipped with three radar sensors each are driving. The cars

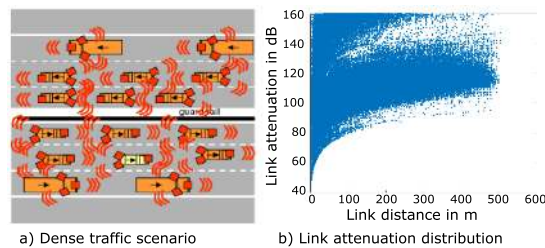

**FIGURE 14.** Simulation of dense traffic interference [63].

are randomly distributed having a minimum distance of 4 meters when driving on the same lane. A simplified propagation model that takes into account transmit and receive antennas, free space propagation, first order reflections, and heuristic blockage attenuation is used to calculate the propagation between radar sensors of arbitrary vehicles. The distribution of the attenuation is plotted in 14b). The plot shows that there is a significant amount of signals coming from radar transmitters distributed over the highway that can be received by a victim receiver. This can potentially cause interference, leading to decreased sensitivity, reduced measurement accuracy, or in rare cases to sensor blindness. This is not acceptable for safety-relevant functions like the automatic emergency brake or vulnerable road user protection of pedestrians. Therefore, measures to mitigate interference are being investigated. Interference mitigation between sensors can be broadly divided into one of the three categories: detect and repair, active avoidance, and cooperation.

Detect and repair means recognizing impacted receive signals and restoring the waveform as close as possible to the undistorted original [64], [65]. In addition to FMCW, this approach has also been demonstrated for modulation schemes like phase modulated continuous wave (PMCW) and orthogonal frequency division multiplexing (OFDM) radar [66]. Avoidance is a well-known practice in RF communication and used universally in lightly regulated frequency bands. Using an analyze-before-measure approach, the transmitting device listens before transmission and changes its operational parameters like transmit direction or center frequency in order to avoid conflicts, as shown for example in [67]. This can be supplemented by a cooperative interference mitigation approach, that can be either rule-based or using a communication channel. In a rule-based setup every radar sensor has a fixed set of common rules that determine the reaction to interference, while a communications-based approach typically relies on a central instance to arbitrate between the sensors [68].

Detect and repair is standard for radar sensors on the market today, avoidance schemes are being worked by the industry, while cooperative operation is still mostly a future topic.

**IV. UPCOMING DEVELOPMENTS**

With the significant decrease in costs of millimeter wave hardware components, MMICs, and hardware systems, research

on automotive radar has shifted its focus from hardware related topics onto system topics in recent years. Today, the system specifies the hardware requirements, and since hardware capabilities are often not anymore the limiting factor, sophisticated system concepts with high-performance imaging qualities will come up. In the following, today's key research areas in automotive radar that allow for sophisticated systems are discussed. Digital modulation schemes and compressed sensing in Sections IV-A and IV-B are powerful tools for future automotive radar systems. Whereas in the past sensor properties like bandwidth, observation time, and aperture were typically scaled to reach the next level of resolution or imaging quality, respectively, future radar sensor networks are a serious alternative allowing to reach better imaging performance, shown in Section IV-C. As will be shown later, such networks can even build on low-performance sensors as network nodes. Based on that, Section IV-D discusses new imaging approaches for automotive applications, i.e. synthetic aperture radar (SAR) and grid mapping. Machine learning for automotive radar as huge driver for fundamentally new signal processing concepts is briefly addressed in Section IV-E.

### A. DIGITAL MODULATION

Orthogonal frequency division multiplex (OFDM) and phase modulated continuous wave (PMCW; in automotive context often called PN radar) are the main digital modulation schemes under investigation for future automotive radars. Comprehensive overview papers on digital modulation schemes and interference of automotive radars have recently been published [66], [69], therefore, this topic is only mentioned briefly here. Since resolution limits are not a function of the type of modulation scheme but a property of bandwidth, observation time and aperture, better imaging quality is not an advantage of digital modulations. These are rather among others as follows:

- Digital radars offer an enormous flexibility in terms of signal processing compared to analog radars.
- The 77 GHz signal is available as a baseband signal, i.e. the filter function by the analog FMCW hardware is eliminated. This allows e.g. for simple and flexible interference mitigation techniques.
- Bistatic radar operation with at least two digital radars enables easy carrier recovery, a great advantage for setting up coherent radar networks, as discussed later.

Typical automotive radar sensors come with bandwidths of several hundred MHz up to 1 GHz, in future with up to 4 GHz in the 77–81 GHz band, to offer a high range resolution. For a long time, these large bandwidths and the enormous data rates associated with them prevented digital radar from being used in the automotive sector and were therefore the most important disadvantage of digital radars. Current research has addressed this topic and sophisticated radar system concepts have been introduced, reducing the enormous data rates by different types of subsampling like introducing steps of the carrier frequency, see Fig. 15 from [70], [71] or the use of compressed sensing [72].

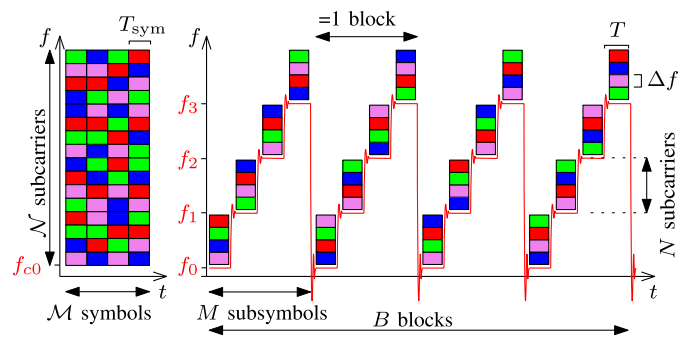
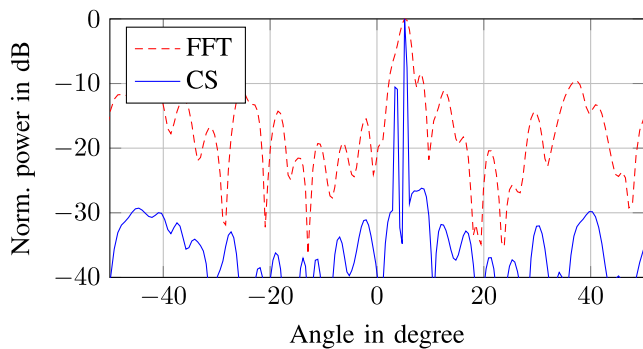

**FIGURE 15. OFDM signal in frequency domain, colors represent QPSK codes. Left: standard OFDM, the signal is divided into  $M$  symbols in time domain and into  $N$  subcarriers into frequency domain. Right: new scheme realized by a stepped carrier (red), allowing for a reduction of the ADC rate by a factor corresponding to the number of steps. Adapted from [70].**

### B. COMPRESSED SENSING

Considering the range-velocity or range-azimuth domains of a measurement in an automotive environment, the number of potential target resolution cells is typically much larger than the number of targets (reflections), even for high-resolution sensors. Hence, the information content of the signal is much lower than the number of resolution cells and samples collected. Therefore, radar problems are typically sparse and compressible in range, velocity, and angle. Exploiting this sparsity property gives the opportunity of undersampling the corresponding measurement domains by compressed sensing (CS) techniques, that allow robust sampling of signals beyond the Nyquist-Shannon limit. Radar signals may be sparse in all measurement dimensions. CS is used in order to reduce bandwidth (ADC rate), the amount of collected data or the number of antennas, respectively, and thereby hardware complexity. To apply CS it is important that the undersampling pattern is approximately random and aperiodic [73]. Applying conventional compression to the subsampled measurements results in high sidelobes in the radar image while using CS approaches instead mitigates these sidelobes. This idea was first brought up by [73] to reduce the ADC rate by leaving out samples and reconstructing them. In [74]–[76], frequency agile radars with reduced bandwidth are proposed that use CS instead of a matched filter compression. In [72], it is shown that only 20% of the resolution bandwidth is sufficient to accurately recover targets.

CS is particularly popular for direction of arrival (DOA) estimation, as shown in the example in Fig. 16. In [79] bounds on the number of targets recoverable in the angular domain are derived. In [78], [80]–[82], CS is combined with sparse antenna arrays to increase both target estimation robustness and accuracy without increasing the number of required physical antennas. The results show that sidelobes in DOA estimation are mitigated, and CS is capable of better performance than sophisticated methods such as MUSIC. Measurements of an automotive FMCW MIMO sparse array with CS DOA estimation are investigated in [78]. The results show that targets within the same range-velocity cell with up to 10 dB



**FIGURE 16.** Measurements using a sparse  $4 \times 8$  MIMO array and two close targets with angular spacing of  $2.6^\circ$  and an RCS difference of 9 dB. Conventional FFT beamforming yields sidelobes due to the non-equidistant spacing of the antennas. Moreover, the two targets are not distinguishable. Using CS evaluation (here: iterative method with adaptive threshold (IMAT) see [77]), the sidelobes are mitigated and the close targets are distinguishable. Figure taken from [78].

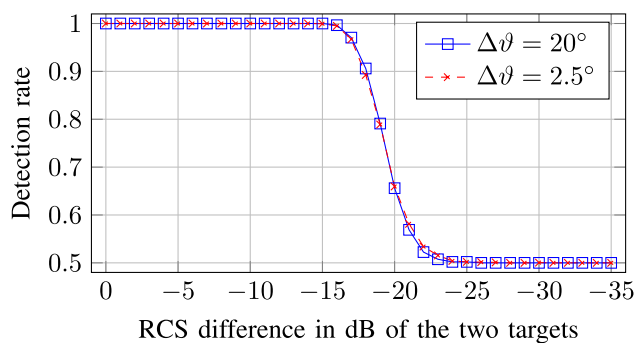
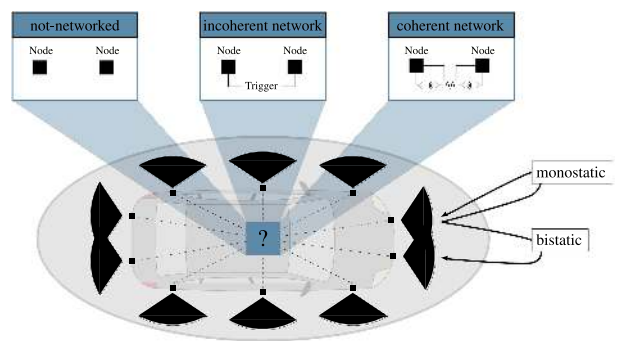

**FIGURE 17.** Detection rate of two targets with different RCS, that are only separable in the angular domain. For RCS differences larger than approx. 15 dB the detection rate drops significantly, interestingly independent of the angular spacing  $\Delta\theta$  of the targets. Figure taken from [78].

difference in RCS are still distinguishable with CS, which in turn reveals a clear restriction on the use of compressed sensing in the automotive sector. Typically, no more than 10–20 dB difference in RCS are acceptable to distinguish targets in any measurement dimension with most CS algorithms, as shown in Fig. 17. In addition, CS algorithms always lead to an increased computational effort compared to standard approaches, see [83].

### C. RADAR NETWORKS

In modern midsize and larger cars typically several radar sensors are employed, each serving different functions coming with tailored and function-specific fields of view. With that many sensors in a single car, fusion of the sensor data and therewith setting up a complete network of radar sensors gets attractive, see Fig. 18. Radar networks promise an improved detection performance due to the diversity provided by the network and much better angular performance, see an example in Fig. 19, in particular if the whole network spans an aperture being much larger than the single sensor’s aperture. In addition to improving classic radar parameters, networks also



**FIGURE 18.** Today’s automotive radar sensors are typically not networked by a low level fusion, only high abstraction layers are merged (left). Low level fusion leads to a large variety of different network architectures from incoherent to fully coherent networks (right).

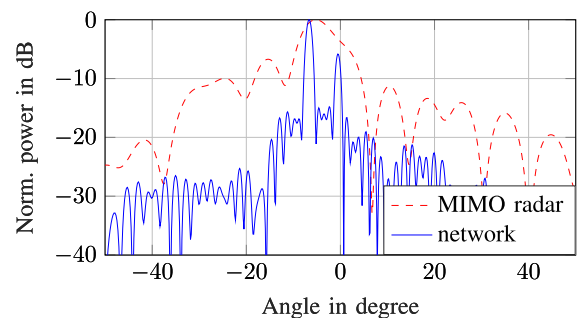

**FIGURE 19.** Measurement with a single MIMO radar (aperture 3 cm) in comparison to a coherent network (aperture 16 cm) of a scenario with two targets at  $0^\circ$  and  $-5.2^\circ$ .

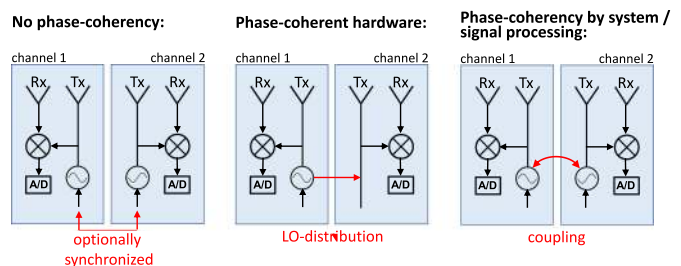

**FIGURE 20.** Comparison of different network architectures based on FMCW sensors from non-coherent networks (left) to coherent networks, where coherency can either be realized classically on a hardware level or on system and signal processing level.

provide the ability for totally new functions like ego-motion estimation [84] or improved grid-mapping as discussed later.

In the literature, radar system concepts with several separated sensors or transmitters are called radar networks, multi-static concepts, or netted radar. These concepts can be further subdivided depending on their kind of linkage between the sensor nodes, monostatic and bistatic operation of the nodes, the type of sensor fusion, and the important question of coherent or incoherent operation, see Fig. 20. Additionally, coherency may exist in the dimensions of space, time, frequency, and phase [85]. In the automotive context, the term coherency



typically refers to phase coherency between different sensor nodes in a network.

Sensor data fusion on tracking and object level, i.e. after the raw-data processing in each single sensor of a network, is not considered in this paper, since those highly abstracted signal processing layers are typically out of interest of the microwave community. Fusion on this high level is well established today, but coming with the drawback that much of the information contained in the raw data signal is already lost. Hence, in the following, the focus is on networks based on raw data fusion.

In case there is no coherency and even no synchronization between the sensor nodes and each sensor measures monostatically only, the implementation of the network is rather simple. Such automotive radar networks are typically built on simple sensor nodes, sometimes even without the ability to measure angles [86], [87]. Angles of the targets are then estimated by employing multi-lateration techniques based classically on range measurements [88] and also on velocity evaluation [89], which helps reducing ambiguities or improving the angular estimation performance of the network. Multi-lateration in automotive scenarios suffers from ambiguities, in particular as most targets in the automotive context appear as extended targets with many scattering centers. Incoherent networks with synchronization of the sensor nodes operate in a cooperative way, which is also called distributed MIMO [90] or netted radar [91]. Such networks operate coherently regarding space, time, and frequency, but not phase. Hence, they do not provide a coherent processing gain, but by exploiting the angular diversity robustness is increased [92]. In [93] a bistatic incoherent network was proposed which compensates timing differences of the sensor nodes by proper signal processing.

Phase coherent radar networks share the advantages of incoherent networks but provide an additional coherent processing gain and large apertures for angle estimation, see Fig. 19. Consequently, they are the most powerful group of networks. Wired connections using microwave transmission lines or optical fibers are a simple way of coherently coupling sensors [85], [94]. Since those hardware couplings are typically not acceptable for vehicle integration, a key research direction is today the establishment of coherent multistatic networks without hardware links, i.e., the coherency is realized by sophisticated system concepts and signal processing. Many of those concepts built up on the two sensor networks are published in [95]. A concepts for  $N$  FMCW-sensors was presented in [96] with coherent processing in [97]. Alternative concepts comprise the integration of radar repeaters into the networks [98]. Even interferometric concepts have recently been proposed [99]. Most of those network approaches suffer from very sparse apertures and therewith angular ambiguities, in particular if the apertures span large parts of the vehicle. A typical countermeasure to suppress ambiguities in the angular domain is CS [98], as presented before.

#### D. GRID MAPPING AND AUTOMOTIVE SAR

With increasing requirements of the radar sensors for more and more advanced functions towards autonomous driving, a

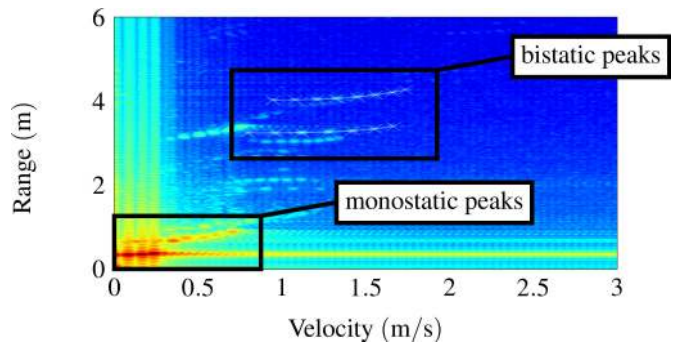

**FIGURE 21.** Measurement of a coherent automotive radar network that comprises time-series of monostatic and bistatic range-velocity-measurements. Based on the monostatic and bistatic measurements the motion vector of the target can be estimated, as the target is measured from two different perspectives [100].

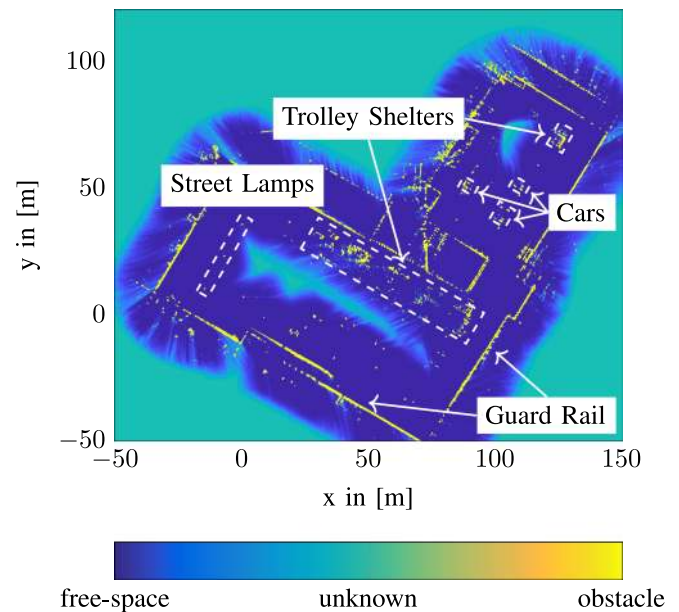

**FIGURE 22.** Occupancy grid map based on a measurement by  $4 \times 4$  MIMO radar sensors at 76 GHz with 1 GHz bandwidth and localization of the radar sensor by GPS.

complete mapping of the environment needs to be provided by the radar sensors, whereas earlier sensors only created target lists for higher level functions. In general, two maps are currently being investigated, i.e. the grid map and SAR images (synthetic aperture radar). Both concepts differ fundamentally from each other. While grid maps are based on target lists and thus are created after raw data signal processing and benefit from a non-coherent integration gain, SAR images are based on raw data and benefit from a coherent integration gain. Grid maps are divided into amplitude grid maps and the much more common occupancy grid maps [101], which represent the probabilistic cell states of the environment. This means occupancy grid maps allow for a distinction between free space, obstacles, and an unknown area, as shown in the example in Fig 22. In contrast to feature-based approaches, the free space and the occupied space is directly visible in such maps

and does not have to be interpolated or calculated additionally [102], [103]. Due to the probabilistic cell representation, neither ghost targets are represented as real targets nor hidden targets as free space, which enables a highly accurate and very robust map. For many years, the radar sensors were not yet powerful enough to create high-resolution grid maps of the environment, but today's powerful sensors enable a high-resolution image of the environment [104]. A GNSS-based localization of the sensor is nowadays sufficient to create an occupancy grid map out of radar data [101], [105]–[107].

As shown in the example in Fig. 22, the parking lot border as well as buildings or lamp posts are clearly recognizable. Furthermore, the clear separation between free space and obstacles is easily recognizable. Future approaches aim at radar-based prediction of the environment and motion vectors of both the own one and the ones of other road users. This allows two dynamic grid maps to be created, which are also completely independent of additional localization systems such as GNSS [108]. Furthermore, the use of a 2D-antenna characteristic also enables a 3D-occupancy grid map of the environment [109]. The disadvantage of occupancy grid maps is that they are based exclusively on target lists, hence rather small, simple and not so high-performance radar sensors can hardly be used for the generation of high quality occupancy gridmaps. In contrast, SAR images may be generated by rather simple and low-performance sensors, but the localization accuracy of the sensors needs to be high. Automotive SAR images are based on the idea of exploiting the movement of a vehicle in order to span large apertures. In the automotive sector, such approaches were deeply investigated since 2009 [110]. The advantage of SAR images over grid maps is the resulting resolution, which can be improved from a couple of 10 cm to centimeters or even millimeters [111], [112]. Due to the small wavelength, this high-resolution image requires high-precision localization methods, which generally cannot be achieved by the use of GNSS solely [113]. Radar network-based ego motion estimation is one approach for localization allowing for coherent SAR images, being processed on the basis of various position estimates for short measurement sequences over a few seconds, see Fig. 23. Both building edges and car contours are clearly visible, which cannot be represented at this precision in occupancy grid maps.

Current research mainly focuses on the localization of the antennas and auto-focusing methods in order to span a synthetic aperture along an arbitrarily long trajectory [114]–[116].

### E. MACHINE LEARNING AND AUTOMOTIVE RADAR

During the last few years machine learning (ML) techniques were increasingly applied also in research on automotive radar. First applied on SAR data, classification algorithms have been recently applied to distinguish between various types of targets detected by radar [117]–[120]. A special case of target identification that has attracted particular interest is the recognition of vulnerable road users (VRU) such as pedestrians, either based on  $\mu$ Doppler signatures [121]–[123],

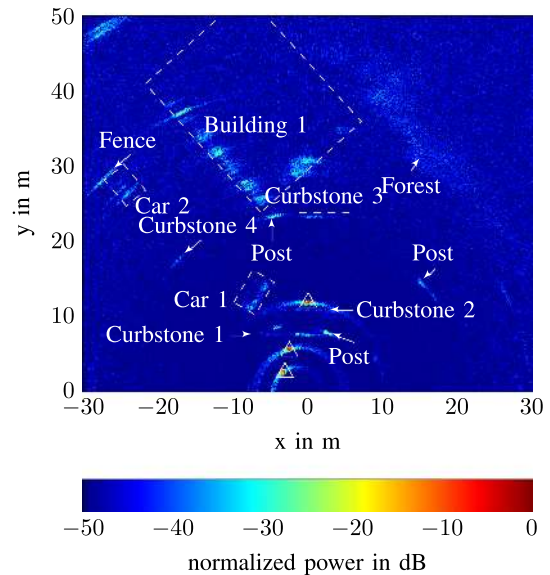

**FIGURE 23.** Automotive SAR image based on a network of radar sensors that moves 8 cm only. The localization data required for SAR processing is obtained by ego motion estimation of the network [116].

range-velocity spectra [124], [125], or other [126]. Besides classification of specific targets, deep learning can provide better scene understanding by semantic segmentation [127]. For radar, the surroundings of vehicles have been successfully assigned to different categories based on grid maps [128], point clouds [129], and utilizing both [130]. In [131], region of interest-based segmentation is applied to range-velocity spectra. Moving beyond single-radar scenarios, different authors started exploring the use of machine learning algorithms to detect and mitigate interference between various radar types. The scope of work ranges from classifying the interference type [132] to interference mitigation using denoising neural networks such as convolutional neural network [133], auto-encoder [134], [135], or recurrent neural networks [136].

An important topic for the microwave community is the generation of large datasets for training the networks. Annotating radar data from measurements, i.e. adding information about the scene and targets, is a very exhausting process, particularly for automotive scenarios. Hence different approaches for the generation of simulated or synthetically generated datasets have been presented mainly in the last three years. [137] proposes a semi-automatic labeling based on radar, Lidar, and camera data. In [138], radar measurements are enriched with GNSS ground-truth for ML-based VRU recognition. Furthermore, synthesizing VRU radar responses with radar simulators has been presented with the motion ground-truth obtained from kinematic models [139], animations [140], [141], or Kinect data [142], [143].

### V. CONCLUSION

This paper has shown the development of automotive radar over the past decades and addressed today's new research

directions. A clear trend is the increasing differentiation of standard low-cost sensors for driver assistance applications and high-performance sensors for autonomous driving. Since the research focus is moving away from pure hardware topics, the new topics are more diverse and play at different levels of the sensor system. On hardware level, more and more components are integrated in CMOS technologies into a single IC, including the classical MMIC components together with the circuitry for signal synthesis and signal processing. Signal processing and hardware design are growing together more and more and can no longer be considered separately from one another. MIMO antenna designs, digital modulation schemes and radar networks show this trend clearly. We expect sensor systems in the coming years to be much more powerful than today's ones, as research on a comprehensive system level has only just begun.

## REFERENCES

- [1] "EuroNCAP 2020 Roadmap," 2015. [Online]. Available: <https://cdn.euroncap.com/media/16472/euro-ncap-2020-roadmap-rev1-march-2015.pdf>
- [2] European Telecommunications Standards Institute (ETSI), *Short Range Devices; Transport and Traffic Telematics (TTT); Short Range Radar Equipment Operating in the 77 GHz to 81 GHz Band; Harmonised Standard Covering the Essential Requirements of Article 3.2 of Directive 2014/53/EU*, ETSI EN 302 264, Sophia Antipolis, France, 2017.
- [3] Federal Communications Commission, FCC-CIRC1707-07, Washington, DC, USA, 2017. [Online]. Available: <https://docs.fcc.gov/public/attachments/DOC-345476A1.pdf>
- [4] M. Köehler, J. Hasch, H. L. Bloecher, and L. P. Schmidt, "Feasibility of automotive radar at frequencies beyond 100 GHz," *Int. J. Microw. Wireless Technol.*, pp. 49–54, 2013.
- [5] A. L. Merlo, "Automotive radar for the prevention of collisions," *IEEE Trans. Ind. Electron. Control Instrum.*, vol. IECI-11, no. 1, pp. 1–6, Feb. 1964.
- [6] W. Harokopus, "Application of radar to automobile control and sensing," in *IEEE GMTT Int. Microw. Symp. Dig.*, 1971, pp. 168–169.
- [7] E. Baghdady, "Automobile RADAR," in *IEEE GMTT Int. Microw. Symp. Dig.*, 1971, pp. 22–35.
- [8] J. Stevens and L. Nagy, "A duplex Doppler radar automotive obstacle detection system," in *Proc. 23rd IEEE Veh. Technol. Conf.*, 1972, pp. 34–44.
- [9] F. Holmstrom, J. Hopkins, M. Hazel, A. Newfell, and E. White, "Microwave design optimization of the TSC automobile crash sensor," in *Proc. IEEE GMTT Int. Microw. Symp.*, 1972, pp. 142–144.
- [10] J. Stevens and L. Nagy, "Duplex Doppler radar for automotive obstacle detection," *IEEE Trans. Veh. Technol.*, vol. 23, no. 2, pp. 34–44, May 1974.
- [11] D. Grimes and T. Jones, "Automotive radar: A brief review," *Proc. IEEE*, vol. 62, no. 6, pp. 804–822, 1974.
- [12] L. Nagy and J. Lyon, "An ultrashort pulse radar sensor for vehicular pre-collision obstacle detection," *IEEE Trans. Veh. Technol.*, vol. 24, no. 4, pp. 41–45, Nov. 1975.
- [13] G. Kaplan and F. Sterzer, "Dual-mode automobile collision avoidance RADAR," in *Proc. IEEE-MTT-S Int. Microw. Symp.*, 1975, pp. 812–817.
- [14] E. Belohoubek, J. Cusack, J. Risko, and J. Rosen, "Microcomputer controlled radar and display system for cars," SAE Tech. Paper 770267, 1977, pp. 1849–1853.
- [15] E. Belohoubek, "Radar control for automotive collision mitigation and headway spacing," *IEEE Trans. Veh. Technol.*, vol. 31, no. 2, pp. 89–99, May 1982.
- [16] M. Kiyoto, T. Kondoh, K. Ban, and K. Shirahata, "Radar sensor for automobiles," in *Proc. IEEE Int. Solid-State Circuits Conf.*, 1974, pp. 438–442.
- [17] T. Tamama *et al.*, "RADAR sensor for automotive collision prevention," in *IEEE-MTT-S Int. Microw. Symp. Dig.*, 1978, pp. 168–170.
- [18] G. Hahlganss and L. Hahn, "Headway radar using pulse techniques," in *Proc. Int. Conf. Autom. Electron.*, Jul. 1976, pp. 132–135.
- [19] K. Lindner and W. Wiesbeck, "35-GHz-Impulsradarsensor zur Verwendung in Abstandswarngeräten für Kraftfahrzeuge, (35-GHz pulse radar for car distance warning applications)," *Nachrichtentechnische Zeitung*, no. Z29, H9, Sep. 1976, pp. 667–672.
- [20] D. Z. Heiden and H. Oehlen, "Radar anticollision warning system for road vehicles," *Proc. Elect. Commun.*, vol. 52, no. 2, pp. 141–145, 1977.
- [21] G. Neiningner, "An FM/CW radar with high resolution in range and Doppler: Application for anti-collision radar for vehicles," in *Proc. IEE Conf.*, London, U.K., Oct. 1977, pp. 526–530.
- [22] E. H. Duell and H. J. Peters, "Collision avoidance system for automobiles," in *Proc. SAE Trans.*, no. 87, Section 2: 780230–780458, 1978, pp. 1250–1260.
- [23] C. A. Liechti, "Microwave field-effect transistors," *IEEE Trans. Microw. Theory Techn.*, vol. 24, pp. 279–300, 1976.
- [24] O. K. Nilssen, "New methods of range measuring Doppler radar," *IRE Trans. Aerosp. Navigat. Electron.*, vol. ANE-9, no. 4, pp. 255–265, Dec. 1962.
- [25] Y. Ishikawa, T. Tanizaki, H. Nishida, and Y. Taguchi, "60 GHz band FM-pulse automotive radar front end using new type NRD guide and dielectric lens antenna," in *Proc. Top. Symp. Millimeter Waves.*, vol. Cat. No.97TH8274, 1997.
- [26] A. Krizhevsky, I. Sutskever, and G. E. Hinton, "Imagenet classification with deep convolutional neural networks," in *Proc. Adv. Neural Inf. Process. Syst.*, 2012, pp. 1097–1105.
- [27] J. Woll, "Monopulse Doppler radar for vehicle applications," in *Proc. IEEE Intell. Veh. Symp.*, Detroit, MI, USA, 1995, pp. 42–47.
- [28] I. Gresham *et al.*, "A compact manufacturable 76–77-GHz radar module for commercial ACC applications," *IEEE Trans. Microw. Theory Techn.*, vol. 49, no. 1, pp. 44–58, Jan. 2001.
- [29] M. Camiade, D. Domnesque, P. Alleaume, A. Mallet, D. Pons, and H. Daembkes, "Full MMIC millimeter-wave front-end for a 76.5 GHz adaptive cruise control car radar," in *IEEE MTT-S Int. Microw. Symp. Dig.*, 1999, pp. 1489–1492.
- [30] W. Menzel and A. Moebius, "Antenna concepts for millimeter-wave automotive radar sensors," *Proc. IEEE*, vol. 100, no. 7, pp. 2372–2379, Jul. 2012.
- [31] W. Menzel, D. Pilz, and R. Leberer, "A 77 GHz FM/CW radar front-end with a low-profile, low-loss printed antenna," *IEEE Trans. Microw. Theory Techn.*, vol. 47, pp. 2337–2341, Dec. 1999.
- [32] H. P. Forstner *et al.*, "77 GHz 4-channel automotive radar transceiver in SiGe," in *IEEE MTT-S Int. Microw. Symp. Dig.*, 2008, pp. 233–236.
- [33] T. Binzer, M. Klar, and V. Gross, "Development of 77 GHz radar lens antennas for automotive applications based on given requirements," in *Proc. 2nd Int. ITG Conf. Antennas*, 2007, pp. 205–209.
- [34] T. Meyer, G. Ofner, S. Braddl, M. Brunnbauer, and R. Hagen, "Embedded wafer level ball grid array (eWLB)," in *Proc. 10th Electron. Packag. Technol. Conf.*, 2008, pp. 994–998.
- [35] Y. Asano, S. Ohshima, T. Harada, M. Ogawa, and K. Nishikawa, "Proposal of millimeter-wave holographic radar with antenna switching," in *IEEE MTT-S Int. Microw. Symp. Dig.*, vol. 2, 2001, pp. 1111–1114.
- [36] E. Fishler, A. Haimovich, R. Blum, D. Chizhik, L. Cimini, and R. Valenzuela, "MIMO radar: An idea whose time has come," in *Proc. IEEE Radar Conf.*, 2004, pp. 71–78.
- [37] W. Mayer, S. Buntz, H. Leier, and W. Menzel, "Imaging radar sensor front-end with a large transmit array," in *Proc. 1st Eur. Radar Conf.*, 2004, pp. 153–156.
- [38] A. Stelzer, R. Feger, and M. Jahn, "Highly-integrated multi-channel radar sensors in sige technology for automotive frequencies and beyond," in *Proc. 20th Int. Conf. Appl. Electromagn. Commun.*, Dubrovnik, 2010, pp. 1–11.
- [39] N. Kees, E. Schmidhammer, and J. Detlefsen, "Improvement of angular resolution of a millimeterwave imaging system by transmitter location multiplexing," in *Proc. IEEE MTT-S Int. Microw. Symp.*, vol. 2, 1995, pp. 969–972.
- [40] G. Hakobyan and B. Yang, "High-performance automotive radar: A review of signal processing algorithms and modulation schemes," *IEEE Signal Process. Mag.*, vol. 36, no. 5, pp. 32–44, Sep. 2019.
- [41] N. Arkind, "WF-04: On a time multiplexed MIMO frequency hopping automotive radar," in *Proc. Eur. Microw. Conf.*, 2018.

- [42] “Digital modulation radar (DCM) for automotive application,” 2020. [Online]. Available: [https://www.uhnder.com/images/data/DCM\\_Radar\\_for\\_Automotive\\_Application\\_Final.pdf](https://www.uhnder.com/images/data/DCM_Radar_for_Automotive_Application_Final.pdf)
- [43] “Radar for automotive: Automated driving applications strengthens market dynamics,” 2019. [Online]. Available: [http://www.yole.fr/iso\\_upload/News/2019/PR\\_RADAR\\_for\\_AUTOMOTIVE\\_RadarMarketUpdate\\_YOLE\\_May2019.pdf](http://www.yole.fr/iso_upload/News/2019/PR_RADAR_for_AUTOMOTIVE_RadarMarketUpdate_YOLE_May2019.pdf)
- [44] “Front radar sensor,” 2020. [Online]. Available: <https://bosch.com>
- [45] C. Vasanelli, F. Bögelsack, and C. Waldschmidt, “Reducing the radar cross section of microstrip arrays using AMC structures for the vehicle integration of automotive radars,” *IEEE Trans. Antennas Propag.*, vol. 66, no. 3, pp. 1456–1464, Mar. 2018.
- [46] J. Hasch, E. Topak, R. Schnabel, T. Zwick, R. Weigel, and C. Waldschmidt, “Millimeter-wave technology for automotive radar sensors in the 77 GHz frequency band,” *IEEE Trans. Microw. Theory Techn.*, vol. 60, no. 3, pp. 845–860, Mar. 2012.
- [47] M. Kronauge and H. Rohling, “New chirp sequence radar waveform,” *IEEE Trans. Aerosp. Electron. Syst.*, vol. 50, no. 4, pp. 2870–2877, Oct. 2014.
- [48] A. Zwanetski, M. Kronauge, and H. Rohling, “Waveform design for FMCW MIMO radar based on frequency division,” in *Proc. 14th Int. Radar Symp.*, 2013, pp. 89–94.
- [49] R. Feger, C. Pfeffer, and A. Stelzer, “A frequency-division MIMO FMCW radar system using delta-sigma-based transmitters,” in *Proc. IEEE MTT-S Int. Microw. Symp.*, 2014, pp. 1–4.
- [50] E. H. Kim and K. H. Kim, “Random phase code for automotive MIMO radars using combined frequency shift keying-linear FMCW waveform,” *IET Radar Sonar Navigat.*, vol. 12, no. 10, pp. 1090–1095, 2018.
- [51] A. Santra, A. R. Ganis, J. Mietzner, and V. Ziegler, “Ambiguity function and imaging performance of coded FMCW waveforms with fast 4D receiver processing in MIMO radar,” *Digital Signal Process.*, vol. 97, p. 102618, 2020.
- [52] M. Camiade, “Overview on GaAs MMICs for automotive radar,” in *Proc. 24th Annu. Tech. Dig. Gallium Arsenide Integr. Circuit Symp.*, 2002, pp. 29–32.
- [53] R. Lachner, “WF-04: Overview of new Si-based mm-Wave technologies and packaging solutions,” in *Proc. Eur. Microw. Conf.*, 2018.
- [54] Y.-A. Li, M.-H. Hung, S.-J. Huang, and J. Lee, “A fully integrated 77 GHz FMCW radar system in 65 nm CMOS,” in *Proc. IEEE Int. Solid-State Circuits Conf. (ISSCC)*, 2010, pp. 216–217.
- [55] T. Usugi, T. Murakami, and Y. A. Utagawa, “A 77 GHz 8RX3TX transceiver for 250 m long range automotive radar in 40 nm CMOS technology,” in *Proc. IEEE Radio Freq. Integr. Circuits Symp.*, Los Angeles, CA, USA, 2020, pp. 23–26.
- [56] P. Ritter et al., “A fully integrated 78 GHz automotive radar system-on-chip in 22 nm FD-SOI CMOS,” in *Proc. Eur. Microw. Conf.*, 2020, pp. 1125–1140.
- [57] D. Sahu et al., “A 45 nm 76–81 GHz CMOS radar receiver for automotive applications,” in *Proc. IEEE Asian Solid-State Circuits Conf. (A-SSCC)*, 2019, pp. 9–12.
- [58] W. Hartner et al., “Reliability and performance of wafer level fan out package for automotive radar,” in *Proc. Int. Wafer Level Packag. Conf.*, 2019, pp. 1–11.
- [59] M. Mi, M. Moallem, J. Chen, M. Li, and R. Murugan, “Package co-design of a fully integrated multimode 76–81 GHz 45 nm RFCMOS FMCW automotive radar transceiver,” in *Proc. IEEE 68th Electron. Compon. Technol. Conf.*, 2018, pp. 1054–1061.
- [60] V. Giannini, C. Pan, M. Ali, C. Davis, and M. Hedge, “WW-01: A package co-design methodology for mm-wave system-on-chip transitions,” in *Proc. Eur. Microw. Conf.*, 2017.
- [61] A. Fischer, Z. Tong, A. Hamidipour, L. Maurer, and A. Stelzer, “77-GHz multi-channel radar transceiver with antenna in package,” *IEEE Trans. Antennas Propag.*, vol. 62, no. 3, pp. 1386–1394, Mar. 2013.
- [62] C.-Y. Ho, S.-C. Hsieh, M.-F. Jhong, H.-C. Kuo, C.-Y. Ting, and C.-C. Wang, “A low-cost antenna-in-package solution for 77 GHz automotive radar applications,” in *Proc. Int. Conf. Electron. Packag.*, 2019, pp. 110–114.
- [63] W. Sörgel, T. Poguntke, and T. Binzer, “WW-02: Workshop radar interference and coexistence, European microwave week,” in *Proc. Eur. Microw. Conf.*, 2019.
- [64] M. Toth, P. Meissner, A. Melzer, and K. Witrisal, “Performance comparison of mutual automotive radar interference mitigation algorithms,” in *Proc. IEEE Radar Conf.*, 2019, pp. 1–6.
- [65] J. Bechter, F. Roos, M. Rahman, and C. Waldschmidt, “Automotive radar interference mitigation using a sparse sampling approach,” in *Proc. Eur. Radar Conf.*, 2017, pp. 90–93.
- [66] F. Roos, J. Bechter, C. Knill, B. Schweizer, and C. Waldschmidt, “Radar sensors for autonomous driving: Modulation schemes and interference mitigation,” *IEEE Microw. Mag.*, vol. 20, no. 9, pp. 58–72, Sep. 2019.
- [67] J. Bechter, C. Sippel, and C. Waldschmidt, “Bats-inspired frequency hopping for mitigation of interference between automotive radars,” in *Proc. IEEE MTT-S Int. Conf. Microw. Intell. Mobility*, 2016, pp. 1–4.
- [68] “V2X-communication assisted interference minimization for automotive radars,” *China Commun.*, vol. 16, no. 10, pp. 100–111, Oct. 2019.
- [69] G. Hakobyan and B. Yang, “High-performance automotive radar: A review of signal processing algorithms and modulation schemes,” *IEEE Signal Process. Mag.*, vol. 36, no. 5, pp. 32–44, Sep. 2019.
- [70] B. Schweizer, C. Knill, D. Schindler, and C. Waldschmidt, “Stepped-carrier OFDM-radar processing scheme to retrieve high-resolution range-velocity profile at low sampling rate,” *IEEE Trans. Microw. Theory Techn.*, vol. 66, no. 3, pp. 1610–1618, Mar. 2018.
- [71] R. Feger, H. Haderer, H. Jalli Ng, and A. Stelzer, “Realization of a sliding-correlator-based continuous-wave pseudorandom binary phase-coded radar operating in W-band,” *IEEE Trans. Microw. Theory Techn.*, vol. 64, no. 10, pp. 3302–3318, Oct. 2016.
- [72] C. Knill, B. Schweizer, S. Sparrer, F. Roos, R. F. H. Fischer, and C. Waldschmidt, “High range and Doppler resolution by application of compressed sensing using low baseband bandwidth OFDM radar,” *IEEE Trans. Microw. Theory Techn.*, vol. 66, no. 7, pp. 3535–3546, Jul. 2018.
- [73] R. Baraniuk and P. Steeghs, “Compressive radar imaging,” in *Proc. IEEE Radar Conf.*, Apr. 2007, pp. 128–133.
- [74] G. Lellouch, R. Pribic, and P. Van Genderen, “Merging frequency Agile OFDM waveforms and compressive sensing into a novel radar concept,” in *Proc. Eur. Radar Conf.*, Sep. 2009, pp. 137–140.
- [75] S. Shah, Y. Yu, and A. Petropulu, “Step-frequency radar with compressive sampling (SFR-CS),” in *Proc. IEEE Int. Conf. Acoust. Speech Signal Process.*, 2010, pp. 1686–1689.
- [76] H. Stahl, J. Mietzner, and R. F. H. Fischer, “A sub-Nyquist radar system based on optimized sensing matrices derived via sparse rulers,” in *Proc. 3rd Int. Workshop Compressed Sens. Theory Appl. Radar, Sonar Remote Sens.*, Jun. 2015, pp. 36–40.
- [77] F. Marvasti et al., “A unified approach to sparse signal processing,” *EURASIP J. Adv. Signal Process.*, no. 44, 2012.
- [78] F. Roos et al., “Compressed sensing based single snapshot DoA estimation for Sparse MIMO radar arrays,” in *Proc. German Microw. Conf.*, Mar. 2019, pp. 75–78.
- [79] T. Strohmer and B. Friedlander, “Compressed sensing for MIMO radar – Algorithms and performance,” in *Conf. Rec. 43rd Asilomar Conf. Signals Syst. Comput.*, vol. 95616, no. 3, 2009, pp. 464–468.
- [80] L. Anitori, M. Otten, and P. Hoogeboom, “Compressive sensing for high resolution radar imaging,” in *Proc. Asia Pacific Microw. Conf.*, 2010, pp. 1809–1812.
- [81] M. Rossi, A. M. Haimovich, and Y. C. Eldar, “Spatial compressive sensing for MIMO radar,” *IEEE Trans. Signal Process.*, vol. 62, no. 2, pp. 419–430, Jan. 2014.
- [82] A. Correas-Serrano and M. A. González-Huici, “Experimental evaluation of compressive sensing for DoA estimation in automotive radar,” in *Proc. 19th Int. Radar Symp.*, Jun. 2018, pp. 1–10.
- [83] F. Roos et al., “Effort considerations of compressed sensing for automotive radar,” in *Proc. IEEE Radio Wireless Symp.*, Jan. 2019, pp. 1–3.
- [84] D. Kellner, M. Barjenbruch, J. Klappstein, J. Dickmann, and K. Dietmayer, “Instantaneous ego-motion estimation using Doppler radar,” in *Proc. 16th Int. IEEE Conf. Intell. Transp. Syst.*, 2013, pp. 869–874.
- [85] P. F. Sarmartino, C. J. Baker, and H. D. Griffiths, “Frequency diverse MIMO techniques for radar,” *IEEE Trans. Aerosp. Electron. Syst.*, vol. 49, no. 1, pp. 201–222, Jan. 2013.
- [86] S. Slater, “Multifunctional automotive radar network,” Tech. Rep. Inform. Soc. Technol., 2004.
- [87] F. Folster, H. Rohling, and U. Lubbert, “An automotive radar network based on 77 GHz FMCW sensors,” in *Proc. IEEE Int. Radar Conf.*, 2005, pp. 871–876.
- [88] M. Klotz and H. Rohling, “A 24 GHz short range radar network for automotive applications,” in *Proc. CIE Int. Conf. Radar Proc. (Cat No. 01TH8559)*, 2001, pp. 115–119.

- [89] M. Steiner, K. S. Osman, and C. Waldschmidt, "Cooperative target detection in a network of single-channel radar sensors," in *Proc. 12th German Microw. Conf.*, 2019, pp. 91–94.
- [90] Qian He, R. S. Blum, and Zishu He, "Noncoherent versus coherent MIMO radar for joint target position and velocity estimation," in *Proc. IEEE CIE Int. Conf. Radar*, vol. 1, 2011, pp. 108–111.
- [91] H. Deng, "Orthogonal netted radar systems," *IEEE Aerosp. Electron. Syst. Mag.*, vol. 27, no. 5, pp. 28–35, May 2012.
- [92] E. Fishler, A. Haimovich, R. Blum, D. Chizhik, L. Cimini, and R. Valenzuela, "MIMO radar: An idea whose time has come," in *Proc. IEEE Radar Conf. (IEEE Cat. No. 04CH37509)*, 2004, pp. 71–78.
- [93] S. Kong, S. Lee, C. Kim, and S. Hong, "Wireless cooperative synchronization of coherent UWB MIMO Radar," *IEEE Trans. Microw. Theory Techn.*, vol. 62, no. 1, pp. 154–165, Jan. 2014.
- [94] J. Lin, "Integration of multiple automotive radar modules based on fiber-wireless network," in *Proc. 24th Wireless Opt. Commun. Conf.*, 2015, pp. 36–39.
- [95] R. Feger, C. Pfeffer, C. M. Schmid, M. J. Lang, Z. Tong, and A. Stelzer, "A 77-GHz FMCW MIMO radar based on loosely coupled stations," in *Proc. 7th German Microw. Conf.*, 2012, pp. 1–4.
- [96] A. Frischen, J. Hasch, and C. Waldschmidt, "A cooperative MIMO radar network using highly integrated FMCW radar sensors," *IEEE Trans. Microw. Theory Techn.*, vol. 65, no. 4, pp. 1355–1366, Apr. 2017.
- [97] A. Frischen, G. Hakobyan, and C. Waldschmidt, "Coherent measurements with MIMO radar networks of incoherent FMCW sensor nodes," *IEEE Microw. Wireless Compon. Lett.*, pp. 1–4, Jul. 2020.
- [98] B. Meinecke, M. Steiner, J. Schlichenmaier, J. Hasch, and C. Waldschmidt, "Coherent multistatic MIMO radar networks based on repeater tags," *IEEE Trans. Microw. Theory Techn.*, vol. 67, no. 9, pp. 3908–3916, Sep. 2019.
- [99] E. Klinefelter and J. A. Nanzer, "Interferometric microwave radar with a feedforward neural network for vehicle speed-over-ground estimation," *IEEE Microw. Wireless Compon. Lett.*, vol. 30, no. 3, pp. 304–307, Mar. 2020.
- [100] B. Meinecke, M. Steiner, J. Schlichenmaier, and C. Waldschmidt, "Instantaneous target velocity estimation using a network of a radar and repeater elements," in *Proc. 16th Eur. Radar Conf.*, 2019, pp. 241–244.
- [101] K. Werber *et al.*, "Automotive radar gridmap representations," in *Proc. IEEE MTT-S Int. Conf. Microw. Intell. Mobility*, 2015, pp. 1–4.
- [102] J. Lombacher, M. Hahn, J. Dickmann, and C. Wöhler, "Detection of arbitrarily rotated parked cars based on radar sensors," in *Proc. 16th Int. Radar Symp.*, 2015, pp. 180–185.
- [103] M. Li, Z. Feng, M. Stolz, M. Kunert, R. Henze, and F. Küçükay, "High resolution radar-based occupancy grid mapping and free space detection," in *VEHITS*, 2018.
- [104] R. Grewe, M. Komar, A. Hohm, S. Lueke, and H. Winner, "Evaluation method and results for the accuracy of an automotive occupancy grid," in *Proc. IEEE Int. Conf. Veh. Electron. Safety*, 2012, pp. 19–24.
- [105] R. Rouveure, M. O. Monod, and P. Faure, "High resolution mapping of the environment with a ground-based radar imager," in *Proc. Int. Radar Conf. Surveillance Safer World (RADAR)*, 2009, pp. 1–6.
- [106] R. Prophet, H. Stark, M. Hoffmann, C. Sturm, and M. Vossiek, "Adaptions for automotive radar based occupancy gridmaps," *IEEE MTT-S Int. Conf. Microw. Intell. Mobility (ICMIM)*, 2018, pp. 1–4, 2018.
- [107] M. Slutsky and D. Dobkin, "Dual inverse sensor model for radar occupancy grids," in *Proc. IEEE Intell. Veh. Symp. (IV)*, 2019, pp. 1760–1767.
- [108] M. Holder, S. Hellwig, and H. Winner, "Real-time pose graph slam based on radar," in *Proc. IEEE Intell. Veh. Symp. (IV)*, 2019, pp. 1145–1151.
- [109] J. Degerman, T. Pernstål, and K. Alenljung, "3D occupancy grid mapping using statistical radar models," in *Proc. IEEE Intell. Veh. Symp. (IV)*, 2016, pp. 902–908.
- [110] H. Wu and T. Zwick, "Automotive SAR for parking lot detection," in *Proc. German Microw. Conf.*, 2009, pp. 1–8.
- [111] R. Feger, A. Haderer, and A. Stelzer, "Experimental verification of a 77-GHz synthetic aperture radar system for automotive applications," in *Proc. IEEE MTT-S Int. Conf. Microw. Intell. Mobility*, 2017, pp. 111–114.
- [112] A. Laribi, M. Hahn, J. Dickmann, and C. Waldschmidt, "Performance investigation of automotive SAR imaging," in *Proc. IEEE MTT-S Int. Conf. Microw. Intell. Mobility*, 2018, pp. 1–4.
- [113] H. Iqbal, M. B. Sajjad, M. Mueller, and C. Waldschmidt, "SAR imaging in an automotive scenario," in *Proc. IEEE 15th Mediterranean Microw. Symp.*, 2015, pp. 1–4.
- [114] T. Gisdler, M. Meinecke, and E. Biebl, "Synthetic aperture radar towards automotive applications," in *Proc. 20th Int. Radar Symp.*, 2019, pp. 1–10.
- [115] M. Steiner, T. Grebner, and C. Waldschmidt, "Chirp-sequence-based imaging using a network of distributed single-channel radar sensors," in *Proc. IEEE MTT-S Int. Conf. Microw. Intell. Mobility*, 2019, pp. 1–4.
- [116] M. Steiner, T. Grebner, and C. Waldschmidt, "Millimeter-wave SAR-imaging with radar networks based on radar self-localization," *IEEE Trans. Microw. Theory Techn.*, vol. 68, no. 11, pp. 4652–4661, Nov. 2020.
- [117] C. Wohler, O. Schumann, M. Hahn, and J. Dickmann, "Comparison of random forest and long short-term memory network performances in classification tasks using radar," in *Proc. Sensor Data Fusion. Trends Solutions Appl.*, 2017, pp. 1–6.
- [118] J. Lombacher, M. Hahn, J. Dickmann, and C. Wohler, "Potential of radar for static object classification using deep learning methods," in *Proc. IEEE MTT-S Int. Conf. Microw. Intell. Mobility*, 2016, pp. 1–4.
- [119] J. Lombacher, M. Hahn, J. Dickmann, and C. Wohler, "Object classification in radar using ensemble methods," in *Proc. IEEE MTT-S Int. Conf. Microw. Intell. Mobility*, 2017, pp. 87–90.
- [120] A. Stroescu, M. Cherniakov, and M. Gashinova, "Classification of high resolution automotive radar imagery for autonomous driving based on deep neural networks," in *Proc. 20th Int. Radar Symp.*, 2019, pp. 1–10.
- [121] P. Sorowka and H. Rohling, "Pedestrian classification with 24 GHz chirp sequence radar," in *Proc. 16th Int. Radar Symp.*, 2015, pp. 167–173.
- [122] Y. Kim and T. Moon, "Human detection and activity classification based on Micro-Doppler signatures using deep convolutional neural networks," *IEEE Geosci. Remote Sens. Lett.*, vol. 13, no. 1, pp. 8–12, Jan. 2016.
- [123] L. Du, L. Li, B. Wang, and J. Xiao, "Micro-Doppler feature extraction based on time-frequency spectrogram for ground moving targets classification with low-resolution radar," *IEEE Sensors J.*, vol. 16, no. 10, pp. 3756–3763, May 2016.
- [124] R. Perez, F. Schubert, R. Rasshofer, and E. Biebl, "Single-frame vulnerable road users classification with a 77 GHz FMCW radar sensor and a convolutional neural network," in *Proc. 19th Int. Radar Symp.*, 2018, pp. 1–10.
- [125] R. Prophet, M. Hoffmann, A. Ossowska, W. Malik, C. Sturm, and M. Vossiek, "Pedestrian classification for 79 GHz automotive radar systems," in *Proc. IEEE Intell. Veh. Symp. (IV)*, 2018, pp. 1265–1270.
- [126] S. Lim, S. Lee, J. Yoon, and S.-C. Kim, "Phase-based target classification using neural network in automotive radar systems," in *Proc. IEEE Radar Conf. (RadarConf)*, 2019, pp. 1–6.
- [127] A. Garcia-Garcia, S. Orts-Escolano, S. Oprea, V. Villena-Martinez, and J. Garcia-Rodriguez, "A review on deep learning techniques applied to semantic segmentation," [Online]. Available: <http://arxiv.org/pdf/1704.06857v1>
- [128] R. Prophet, G. Li, C. Sturm, and M. Vossiek, "Semantic segmentation on automotive radar maps," in *Proc. IV19*, 2019, pp. 756–763.
- [129] O. Schumann, M. Hahn, J. Dickmann, and C. Wohler, "Semantic segmentation on radar point clouds," in *Proc. 21st Int. Conf. Inf. Fusion*, 2018, pp. 2179–2186.
- [130] O. Schumann, J. Lombacher, M. Hahn, C. Wohler, and J. Dickmann, "Scene understanding with automotive radar," *IEEE Trans. Intell. Veh.*, vol. 5, no. 2, pp. 188–203, Jun. 2020.
- [131] K. Patel, K. Rambach, T. Visentin, D. Rusev, M. Pfeiffer, and B. Yang, "Deep learning-based object classification on automotive radar spectra," in *Proc. IEEE Radar Conf. (RadarConf)*, 2019, pp. 1–6.
- [132] R. Zhang and S. Cao, "Support vector machines for classification of automotive radar interference," in *Spurring Innovation*. Piscataway, NJ, USA: IEEE, 2018, pp. 0366–0371.
- [133] J. Rock, M. Toth, E. Messner, P. Meissner, and F. Pernkopf, "Complex signal denoising and interference mitigation for automotive radar using convolutional neural networks," in *Proc. 22nd Int. Conf. Inf. Fusion*, 2019, pp. 1–8.
- [134] S. Abdulatif, K. Armanious, F. Aziz, U. Schneider, and B. Yang, "Towards adversarial denoising of radar micro-Doppler signatures," in *Proc. Int. Radar Conf.*, 2019, pp. 1–6.

- [135] J. Fuchs, A. Dubey, M. Lubke, R. Weigel, and F. Lurz, "Automotive radar interference mitigation using a convolutional autoencoder," in *Proc. IEEE Int. Radar Conf.*, 2020, pp. 315–320.
- [136] J. Mun, H. Kim, and J. Lee, "A deep learning approach for automotive radar interference mitigation," in *Proc. IEEE 88th Veh. Technol. Conf. (VTC-Fall)*, 2018, pp. 1–5.
- [137] M. Meyer and G. Kusch, "Automotive radar dataset for deep learning based 3D object detection," in *Proc. 16th Eur. Radar Conf.*, 2019, pp. 129–132.
- [138] N. Scheiner, N. Appenrodt, J. Dickmann, and B. Sick, "Automated ground truth estimation of vulnerable road users in automotive radar data using GNSS," in *Proc. IEEE MTT-S Int. Conf. Microw. Intell. Mobility*, 2019, pp. 1–5.
- [139] P. van Dorp and F. Groen, "Human walking estimation with radar," *IEEE Signal Process. Lett.*, vol. 150, no. 5, p. 356, Oct. 2003.
- [140] M. Ouza, M. Ulrich, and B. Yang, "A simple radar simulation tool for 3d objects based on blender," in *Proc. 18th Int. Radar Symp.*, 2017, pp. 1–10.
- [141] K. Ishak, N. Appenrodt, J. Dickmann, and C. Waldschmidt, "Advanced radar micro-Doppler simulation environment for human motion applications," in *Proc. IEEE Radar Conf.*, 2019, pp. 1–6.
- [142] B. Erol and S. Z. Gurbuz, "A Kinect-based human micro-Doppler simulator," *IEEE Aerosp. Electron. Syst. Mag.*, vol. 30, no. 5, pp. 6–17, May 2015.
- [143] K. Ishak, N. Appenrodt, J. Dickmann, and C. Waldschmidt, "Human motion training data generation for radar based deep learning applications," in *Proc. IEEE MTT-S Int. Conf. Microw. Intell. Mobility*, 2018, pp. 1–4.

**CHRISTIAN WALDSCHMIDT** (Senior Member, IEEE) received the Dipl.-Ing. (M.S.E.E.) and the Dr.-Ing. (Ph.D.E.E.) degrees from the University Karlsruhe (TH), Karlsruhe, Germany, in 2001 and 2004, respectively. From 2001 to 2004, he was a Research Assistant at the Institut für Höchstfrequenztechnik und Elektronik (IHE), Universität Karlsruhe (TH), Germany. Since 2004, he has been with Robert Bosch GmbH, in the business units Corporate Research and Chassis Systems. He was heading different research and development teams in microwave engineering, RF-sensing, and automotive radar. In 2013, he returned to academia and was appointed as the Director of the Institute of Microwave Engineering at University Ulm, Germany, as Full Professor. He authored or coauthored over 200 scientific publications and more than 20 patents. His research interests focus on radar and RF-sensing, mm-wave and submillimeter wave engineering, antennas and antenna arrays, and RF and array signal processing. Prof. Waldschmidt is a member of the Executive Committee Board of the German MTT/AP Joint Chapter, and a member of the German Information Technology Society (ITG). He served as Chair of the IEEE MTT-27 Technical Committee on wireless enabled automotive and vehicular applications. He was a two-time TPC Chair and General Chair of the IEEE MTT International Conference on Microwaves for Intelligent Mobility. Since 2018, he has been serving as an Associate Editor for IEEE MICROWAVE WIRELESS COMPONENTS LETTERS. He is a reviewer for multiple IEEE transactions and many IEEE conferences in the field of microwaves. He was a co-recipient of 11 best paper awards since 2014.

**JÜRGEN HASCH** (Senior Member, IEEE) received the Dipl.-Ing. and Dr.-Ing. degrees from the University of Stuttgart, Germany, in 1996 and 2007, respectively. He is a Senior Expert on RF Technology at the Corporate Research of Robert Bosch GmbH in Renningen, Germany. He has authored more than 40 scientific papers and holds more than 20 patents. His main research interests include RF-based sensing technologies, integrated millimeter wave sensors in the 60–240 GHz range. Dr. Hasch currently serves as Chair of the IEEE MTT-27 Technical Committee of Connected and Autonomous Systems and a member of ITG-FA Mikrowellentechnik. He serves as a reviewer for several journals and conferences.

**WOLFGANG MENZEL** (Life Fellow, IEEE) received the Dipl.-Ing. degree in electrical engineering from the Technical University of Aachen, Aachen, Germany, in 1974, and the Dr.-Ing. degree from the University of Duisburg, Duisburg, Germany, in 1977. From 1979 to 1989, he was with the Millimeter-Wave Department, AEG, Ulm, Germany (now HENSOLDT). In 1989, he became a Full Professor at the University of Ulm, Ulm, and built up and headed the Institute of Microwave Engineering until his retirement in 2014. His areas of research interest were multilayer planar circuits, waveguide filters and components, antennas, interconnects and packaging, millimeter wave application, and system aspects, including automotive radar. Dr. Menzel was an Associate Editor for IEEE TRANSACTIONS ON MICROWAVE THEORY AND TECHNIQUES (2003–2005). From 1997 to 1999, he was a Distinguished Microwave Lecturer for Microwave/Millimeter Wave Packaging. From 1997 to 2001, he chaired the German IEEE Microwave Theory and Techniques (MTT)/Antennas and Propagation (AP) Chapter. He was the recipient of the 2002 European Microwave Prize and the 2013 Microwave Application Award of the IEEE Microwave Theory and Techniques Society.