

Avian Risk Behavior and Fatalities at the Altamont Wind Resource Area

March 1998 to February 1999

Carl G. Thelander and Lourdes Rugge
BioResource Consultants
Ojai, California



NREL

National Renewable Energy Laboratory

1617 Cole Boulevard
Golden, Colorado 80401-3393

NREL is a U.S. Department of Energy Laboratory
Operated by Midwest Research Institute • Battelle • Bechtel

Contract No. DE-AC36-99-GO10337

Avian Risk Behavior and Fatalities at the Altamont Wind Resource Area

March 1998 to February 1999

Carl G. Thelander and Lourdes Rugge
BioResource Consultants
Ojai, California

NREL Technical Monitor: Karin Sinclair

Prepared under Subcontract No. TAT-8-18209-01



NREL

National Renewable Energy Laboratory

1617 Cole Boulevard
Golden, Colorado 80401-3393

NREL is a U.S. Department of Energy Laboratory
Operated by Midwest Research Institute • Battelle • Bechtel

Contract No. DE-AC36-99-GO10337

NOTICE

This report was prepared as an account of work sponsored by an agency of the United States government. Neither the United States government nor any agency thereof, nor any of their employees, makes any warranty, express or implied, or assumes any legal liability or responsibility for the accuracy, completeness, or usefulness of any information, apparatus, product, or process disclosed, or represents that its use would not infringe privately owned rights. Reference herein to any specific commercial product, process, or service by trade name, trademark, manufacturer, or otherwise does not necessarily constitute or imply its endorsement, recommendation, or favoring by the United States government or any agency thereof. The views and opinions of authors expressed herein do not necessarily state or reflect those of the United States government or any agency thereof.

Available electronically at <http://www.doe.gov/bridge>

Available for a processing fee to U.S. Department of Energy
and its contractors, in paper, from:

U.S. Department of Energy
Office of Scientific and Technical Information
P.O. Box 62
Oak Ridge, TN 37831-0062
phone: 865.576.8401
fax: 865.576.5728
email: reports@adonis.osti.gov

Available for sale to the public, in paper, from:

U.S. Department of Commerce
National Technical Information Service
5285 Port Royal Road
Springfield, VA 22161
phone: 800.553.6847
fax: 703.605.6900
email: orders@ntis.fedworld.gov
online ordering: <http://www.ntis.gov/ordering.htm>



Table of Contents

1.0 INTRODUCTION	1
2.0 OBJECTIVES	1
3.0 STUDY AREA	2
4.0 METHODS	2
4.1 Bird Risk	3
4.2 Bird Fatalities	5
4.3 Scavenging Activities	6
5.0 PRELIMINARY FINDINGS	6
5.1 Bird Risk Behavior	6
5.2 Fatality Searches	7
6.0 DISCUSSION	7
7.0 TABLES AND FIGURES	10
Table 1. The Number of Towers in each of 20 study plots in the Altamont WRA	11
Table 2. Summary of All Bird Observations	12
Table 3. Summary of All Bird Observations by Tower Type	14
Table 4. Summary of Fatalities Recorded	16
Table 5. Summary of All Fatalities Recorded by Tower Type in the Altamont WRA.	17
Figure 1. Turbine tower types represented in the project study plots in the Altamont WRA	18
Figure 2a. Illustration of the zigzag survey route used for fatality searches on relatively level terrain in the Altamont WRA.	19
Figure 2b. Illustration of the zigzag survey route used for fatality searches on relatively steep terrain in the Altamont WRA.	19
8.0 ACKNOWLEDGEMENTS	20
9.0 REFERENCES	20

Foreword

Although the use of wind energy as an alternative electric generation source is now a viable option, there is some concern over the possible impacts of wind turbines on birds. The two primary areas of concern are: (1) the effect of avian mortality resulting from collisions with wind turbines on bird populations, and (2) possible litigation over killing even one bird protected by the Migratory Bird Treaty Act or the Endangered Species Act.

The activities of the avian research program at the National Renewable Energy Laboratory (NREL) focus on minimizing the effects of wind turbines on birds and bird populations. Funded by the U.S. Department of Energy, NREL conducts research (1) to refine the methods developed to assess impacts on birds and bird populations within wind plants, (2) to understand how birds behave in and around wind turbines in different environments, (3) to identify how birds recognize wind turbines and develop recommendations for making the turbines more conspicuous, and (4) to develop recommendations for reducing impacts when they do occur.

This progress report summarizes the NREL-sponsored avian research conducted at the Altamont Wind Resource Area (WRA) in California between March 1998 and February 1999. Field surveys are scheduled to continue through May 2000. A comprehensive report documenting the fieldwork and summarizing analyses of the data is expected to be available in late 2000 or early 2001. We hope these research findings will lead to recommendations of ways to reduce the potential for birds colliding with wind turbines in the Altamont WRA.



Karin C. Sinclair
National Wind Technology Center
National Renewable Energy Laboratory
1617 Cole Boulevard
Golden, Colorado 80401
E-mail: karin_sinclair@nrel.gov
Phone: (303) 384-6946
Fax: (303) 384-6901

1.0 INTRODUCTION

Wind energy development in the Altamont Pass region of California peaked during the mid-1980s, when most of the wind turbine towers now in existence were erected (Hunt 1997). Since 1981, more than 7,000 wind turbines have been installed in the Altamont Wind Resource Area (WRA). Currently about 5,000 are operating, with that number being reduced as repowering continues. They are distributed over an area of approximately 150 km² (Walcott 1995).

In the Altamont WRA, wind speeds average 25–45 km/hr between April and September, when the facility produces 70% to 80% of its power. During winter, the wind speeds drop to 15–25 km/hr. In the summer months, wind speeds are generally sufficient to operate the turbines by mid-afternoon and well into the evening hours.

Since about 1989, several university and private research groups have conducted research on bird interactions with various turbine and tower configurations in the Altamont WRA. Most of these early studies focused on quantifying fatalities and calculating mortality rates for highly vulnerable bird species, specifically raptors.

Although it has long been documented that wind turbines kill birds, especially predator species (i.e., raptors), little is known about specific flight and perching behaviors near wind turbines. What behaviors cause birds to be struck by turbine blades? Can these factors be predicted or quantified in such a way that future wind energy facilities can be designed to avoid or minimize them? Bird fatalities, and how to minimize them, often are a major licensing consideration for any wind energy facility's proponents and for the regulatory agencies responsible for conserving natural resources.

In March 1998, the National Renewable Energy Laboratory (NREL) started a research project designed to address behavior factors that contribute to turbine mortalities. Previously researchers had not attempted to correlate bird flight and perching behaviors with fatality data for the same period and at the same turbines. This approach is the central focus of this project.

This report is intended solely as a progress report. The five tables and three figures referenced in the text appear in a separate section at the end of the report. The findings presented here should be considered preliminary ones. A comprehensive report is scheduled for the end of Phase II.

2.0 OBJECTIVES

The objectives of this project are: (1) to relate bird flight and perching behaviors to mortality risk, and (2) to identify any relationships between these behaviors and turbine/tower type, weather, topography, habitat features, and other factors that may predict high degrees of risk to birds, especially raptors.

Our basic approach is to observe, characterize, and quantify bird flight and perching behaviors in and around wind turbines, and to relate these behavioral data to bird fatalities that occur at the same turbines during the same sampling period. This research should yield information that leads to the design, siting, and operation of wind energy facilities that minimize bird fatalities.

3.0 STUDY AREA

The study area is the Altamont Wind Resource Area (WRA), which was selected by NREL for several reasons. The general region supports a relatively dense breeding population of raptors, especially golden eagles (*Aquila chrysaetos*) (Hunt 1997). It is important winter habitat for migrating raptors and other birds passing through California's Central Valley. Also, there is a relatively urgent need for a solution to the controversy that surrounds future wind energy development and bird fatalities in the Altamont WRA (Morrison 1996; Morrison and Sinclair 1997). Despite the focus on the Altamont WRA, the results of this study should be applicable to other wind energy facilities where bird fatalities may occur.

Altamont Pass is located approximately 90 km east of San Francisco. It divides two distinctly different landscapes in central California. To the west of Altamont Pass are Alameda and southeastern Contra Costa Counties. This is a relatively arid interior portion of the greater San Francisco Bay region. It also is the interface between urban/suburban sprawl and the grasslands and oak woodlands that characterize the Coast Ranges.

To the east of Altamont Pass are generally treeless foothills comprised mainly of annual grasslands. These rolling foothills eventually give way to flat agricultural fields that comprise the Central Valley. Hilltop elevations range from 230 – 470 m above sea level. The lower valley elevations range from 78 – 188 m above sea level (Howell 1997). The primary land use in the Altamont Hills is livestock grazing and dry farming. It is in these foothills east of Altamont Pass and west of the margins of the Central Valley where the Altamont WRA is located.

The vegetation is comprised predominately of non-native annual grasses such as: soft chess (*Bromus hordeaceus*), rip-gut grass (*Bromus diandrus*), foxtail (*Hordeum murinum ssp. leporinum*), Italian ryegrass (*Lolium multiflorum*), and wild oats (*Avena fatua*); and native and non-native wildflowers such as black mustard (*Brassica nigra*), fiddle-neck (*Amsinckia menziesii ssp. intermedia*), chick lupine (*Lupinus microcarpus var. densiflorus*), bush lupine (*Lupinus albifrons*) and wally baskets (*Triteleia laxa*). Annual grasses and flowers emerge during the rainy months of January, February, and March. These die off by late May or early June.

4.0 METHODS

Two basic research efforts make up this project. Each requires a distinctly different set of methods and data collection procedures. The first is behavioral risk observation. The second is fatality searching. We began the study by establishing 17 study plots, which contained 514 turbines. All of these were included in the fatality searches. In February 1999, we increased this sample to 20 plots, for a total of 785 turbines where behavior observations could be conducted. Of these, 685 were accessible for fatality searches.

Landowners provided access to a portion of the Altamont WRA. Based on logistical considerations, we predetermined that biologists could survey 15 – 20 relatively large plots approximately once per week. Within the total area available to us, we located 17 elevated observation points that provided suitably expansive views of a portion of the turbine towers available to us. The sum of all turbine towers visible from these 17 locations equaled all of the turbines in the area to which we had access.

From each of the 17 observation points, we determined the boundaries of each study plot by only including those turbine towers easily and readily visible to the observers from the selected fixed observation point. We made sure not to duplicate any turbine towers between study plots in this process. The result of this plot selection process was a mosaic of irregularly shaped, non-overlapping polygons, each approximately 25 hectares. We included all turbine tower types, turbine string lengths, turbine sites, and general topography present on a portion of the Altamont WRA.

The 785 turbine towers are arranged in 98 different strings. A turbine string is defined as a group, or row, of adjacent turbines separated from other turbines by more than 200 m or by some prominent geographic feature. In our plots, each string length varies from 2–18 turbine towers. A single turbine site refers to the placement of an individual turbine within a string (e.g., middle row, end row, or in a gap or gully).

We designed the behavioral observation methods to maximize the number of bird observations within each of the study plots. We used fatality search protocols that maximized the likelihood of discovering dead birds. The methods used follow the guidelines described in Anderson et al. (1996).

This report includes our findings from early March 1998 through February 1999. Usually, two biologists conducted the studies; however, we sometimes used additional support to maintain our sampling schedule.

4.1 Bird Risk

We began the study by establishing a sampling protocol, designing forms to collect field data, and selecting our study plots. We designed the field studies to detect individual birds within the study plots and to characterize their specific activities. Each of these elements was tested in the field and refined as necessary before formal data collection began. The protocol developed for this study follows the guidelines developed by Morrison (1996), Anderson et al. (1996), and Gauthreaux (1996).

In the 20 sampling plots, we observed bird risk behavior at 785 turbine towers consisting of six different types (see Table 1). This sample represents approximately 15% of the total turbine population in the Altamont WRA. The horizontal lattice towers ($n = 76$) and the SeaWest tubular towers ($n = 24$) that are managed by Green Ridge Services Company (GRS, formerly KENETECH Windpower) are only included in our behavioral observations (not the fatality searches) because we did not have access to those facilities.

In February 1999 we increased our sample to include three new plots, for a total of 171 turbine towers. We will continue to include these in our sampling efforts throughout the study.

We sampled large and small diagonal lattice towers at ENRON. At FORAS, we sampled tubular (Danregn Vind Kraft/Bonus) towers. At Altamont Wind Power, we sampled mostly vertical-axis towers along with some tubular (Danwin) towers. At GRS, we made behavioral observations (no fatality searches) at horizontal lattice towers. Figure 1 shows the basic configuration of each of the turbine towers represented in our sample.

One observer per observation point collected field data. Within each study plot, we selected a point from which we made all behavioral observations. The observation point is a fixed location from which the observer has the best view of the turbines and the surrounding terrain within any study plot. All turbine

towers, and all corners of the plot, are easily viewed from this observation point to ensure accuracy for species identification and documentation of each bird activity.

The observer collected observational data using a technique of circular visual scans (360⁰) known as variable-distance circular-point observations (Reynolds et al. 1980). Each sampling event lasted 30 minutes. The observer, using 8X40 binoculars, recorded all visible bird activity by entering alpha-numeric codes onto a standardized data sheet, and onto a map of the corresponding plot that shows all turbine towers in the plot and their identification numbers. The environmental conditions were recorded after arriving at the plot and before the 30-minute circular scan began. After the observation period was over, the observer moved to the next sampling plot to complete another 30-minute sample.

Once a bird was sighted, it was tracked continuously from the time it entered the plot until it departed. Each of its movements around the turbine towers was noted and recorded. The focus of the behavioral observations was to determine how close to a turbine each bird flies, especially to the zone of risk (i.e., rotor swept area). The estimation of the closest pass to the zone of risk was critical to our study design; therefore, we frequently calibrated each observer's estimates of height and distance using known objects.

Each bird's "utilization duration" was defined as the length of time it was observed within the plot during a 30-minute observation event. The first level of discrimination was whether the bird was flying or perching. If a bird was observed flying only briefly, the minimum duration was one minute, even if the bird(s) departed in less than one minute.

The sample plot observations were stratified by time of day. Morning observations started at 0700 hrs and continued until 1200 hrs. Afternoon sampling started at 1201 hrs and continued until dusk. As many as eight 30-minute point counts were conducted per observer per day. Observations were conducted throughout the year and in nearly every type of weather condition (Morrison 1996). To ensure independence of bird observations, we conducted the 30-minute point counts on nonadjacent plots.

Through February 1999, we observed each study plot at least once per week. Each behavioral session took approximately one hour to complete, including driving time. The order of sampling was systematic to ensure that all turbine tower sites were sampled equally during differing times and environmental conditions.

Observer Bias

In order to reduce the effects of observer bias, we began the field studies by conducting observations using pairs of observers. This helped to minimize any potential differences between observers, and for all observers to become equally familiar with the data sheets and the various bird behaviors. Once the observer's methods and observation skills were standardized, we began conducting separate observations. This standardization process was repeated once per month by conducting paired observations, comparing the observations and adjusting for any differences. During this reporting period five observers participated in data collection.

Prey Availability

Understanding raptor prey availability often provides insights into understanding raptor flight activity, flight behavior, and their distribution; therefore, we recorded a prey availability measurement during each of the behavioral observations. Before the start and at the end of each observation period, we conduct a 360⁰ visual scan of the study plot to count all visible ground squirrels and other small mammals.

We will compile these data to develop an index of prey availability. This information is not intended to yield an absolute count of the prey available to raptors; instead, it provides an estimate of the relative prey availability above ground (i.e., visible) at the time of the observations. These data may provide useful information on raptor distribution in the plots at the time of our point counts. Also, by doing so, we are documenting areas of known and potential ground squirrel activity.

4.2 Bird Fatalities

A database on bird fatalities (primarily raptors) was developed by U.S. Windpower and is currently maintained by Green Ridge Services, Inc., one of the turbine operators in the Altamont WRA (Curry and Kerlinger 1998). Historically, the Wildlife Response and Reporting System (WRRS) database has been comprised of incidental reports of dead birds found mainly by maintenance personnel, plus reports by other researchers using a variety of collection methods. A similar methodology has been proposed as a long-term monitoring procedure for the region.

Until now, no comprehensive data have been collected in the Altamont WRA on the number of fatalities at a fixed sample of turbines over a fixed period of time. For our research, we repeatedly conducted comprehensive searches for all dead birds (i.e., fatality searches) in established study plots over an extended period of time. All turbine towers where behavior data are collected were searched for fatalities, except for the 100 turbines owned by SeaWest where we had no access.

We began the study searching 414 turbine towers. On September 10, 1998, a transformer failed that provided power to operate the turbines in our study plots. A majority of the turbines in our study plots were, therefore, nonoperational until power was restored on December 3, 1998. This reduction in turbine activity provided us the opportunity to search for fatalities at 271 additional turbine towers. We continued to include all 685 turbine towers in our sampling efforts (see Table 4).

Gauthreaux (1996) suggested that any search for bird fatalities around individual turbine towers should be circular and that the minimum radius should be determined by the height of the turbine tower. Because most of the turbine towers included in this study were arranged in strings, these were most efficiently searched by walking a strip along both sides and around the ends. The resulting path, therefore, is best described as a tight zigzag pattern along the strip. Two biologists searched each turbine string simultaneously. On hillsides, we walked parallel to the strings, whereas on level terrain we walked perpendicular to the strings (see Figures 2 and 3).

Previous studies reported that about 75% of all carcasses were found within a 30 – 40 m radius from the turbine towers. They were usually located in the area behind the rotor or on the right front side of it (Orloff and Flannery 1992; Howell 1997). We recorded all dead birds (or bird parts) found during each search within a 50-m radius of the turbine.

All fatalities we found were carefully examined to determine species, estimated age, sex, and probable cause of death. We estimated length of time since death. In addition, we evaluated the general condition of the carcass, the presence/absence of maggots, if the carcass was complete or if dismembered, the types of injuries evident; whether scavenging was evident, carcass position, and the distance and compass heading to the nearest turbine tower. These data were recorded on standardized field data collection forms. Each fatality location was photographed and a copy attached to the fatality report.

In addition to searching wind turbines, we looked for dead birds in the vicinity of any potential bird strike hazard present in the study plot. This included power poles and suspended cables.

We occasionally found feathers during our searches, which we recorded on a data sheet specifically designed for such observations. For each feather, we recorded the following information: date, location, type of feather, and species.

In the coming months, we will use Global Positioning Satellite (GPS) technology to record exactly where we located the carcasses. These data will be incorporated into a Geographic Information Systems (ARC-View GIS) database and plotted on maps. We will use these data to evaluate the topographic conditions and other physical features that relate to where each fatality occurred.

4.3 Scavenging Activities

Orloff and Flannery (1992) reported little evidence of raptor carcass removal by scavengers during their research at the Altamont WRA. To date, we have seen little evidence of scavenging. However, failing to recognize and account for any effect of scavenging may result in an underestimation of the number of dead birds. Therefore, we are determining scavenging rates by conducting carcass removal investigations.

When we find carcasses, we are required to report them to the U.S. Fish and Wildlife Service (USFWS). Carcasses are, however, left in the field for extended periods of time. The exact location is recorded (see above) and flagged to aid in future visits to the carcass. We then visit each site at least every three days, or until the proper authorities collect the carcass. During the time that the carcass is in the field, we record data on the condition of the carcass, amount of decomposition over time, and any evidence of scavenging. This information will help us not only to evaluate the effectiveness of the frequency of our searches, but also to better estimate the approximate time of death for those carcasses we find with unknown dates of death. This information will be useful for future studies of bird fatalities throughout the region.

5.0 PRELIMINARY FINDINGS

The findings presented in this progress report are preliminary. The final report for this project will be a comprehensive analysis of all data collected. Therefore, the data presented here should be cited or distributed with caution since any interpretations based upon them are incomplete at this time.

5.1 Bird Risk Behavior

As of February 28, 1999 we completed 745 sampling events (i.e., 30-minute point counts). We recorded 2,186 bird sightings, representing a minimum of 35 species. The five most frequently observed bird species during the behavioral sessions were red-tailed hawk, followed by common raven, turkey vulture, golden eagle, and California gull (see Table 2).

We recorded flight-related behaviors more frequently than we did perching behaviors. To date, we have recorded 1,702 birds flying within our study plots, which represents 77% of all bird observations. Perching behavior accounts for 23% of the bird sightings (n = 484 perched birds) (see Table 3). Turbine towers were the most commonly used perching structure in our study plots. Turbine towers were used in 44% of the perching observations, followed by 43% on power poles, electrical towers, anemometer towers or fence posts (combined), as well as 13% on the ground or on rocks.

We are planning several analyses using the behavior data that are being collected over two years. The results of these analyses will be a major component of our findings. To do so requires statistical applications and tests of significance that go beyond the scope of this progress report.

5.2 Fatality Searches

Table 4 summarizes 95 bird fatalities and one mammal fatality we recorded between April 4, 1998 and February 28, 1999. From April 4 – November 30, 1998, we searched for fatalities at 414 individual turbine towers on eight separate occasions. These searches revealed 57 bird fatalities (minimum 16 species represented) and one mammal fatality. Raptors represented 46% (n = 26) of all fatalities. Red-tailed hawks are killed most frequently, representing 21% (n = 12) of all fatalities. Golden eagles represent 7% (n = 4) of all fatalities encountered through this reporting period. All fatalities that we found were located near wind turbines.

From December 1, 1998, through the end of February 1999, the sample size for fatality searches increased to 685 turbine towers. During this period, we found an additional 28 recently dead birds (9 species recorded) on three separate occasions. Of these, 55% (n = 21) were raptors. Red-tailed hawks represented seven (18%) fatalities. During these last three months of searches, we also found 10 large raptors that clearly had died long before our study began. Their scattered bones were found buried in grass and soil. They became visible during a period of low grass and rains. These 10 individuals will not be used in our calculations of fatality rates. However, they indicate that an unknown number of dead birds are not reported to the proper authorities.

The frequency of bird fatalities varied with time. We found 51% of all fatalities during the summer months. We found no fatalities during April 1998 and only one bird (non-raptor) during December (see Table 4).

We found 54 (57%) of the dead birds near Bonus tubular turbine towers. Twenty-nine (53%) of these were raptors. We found 31 (33%) dead birds associated with diagonal lattice towers. Of these, 19 (61%) were raptors. We found 10 (10%) dead birds near vertical-axis turbine towers. Of these, one (10%) was a raptor (see Table 5).

The mean distance of the carcasses to the nearest wind turbine tower was 20.2 meters. Additionally, we found 75% of all dead birds less than 30 m from the nearest turbine tower. We recorded 58 (61%) of all dead birds near turbine towers that were not located at the end of a turbine tower string. We found the remaining 37 (39%) carcasses at the end of turbine tower strings.

6.0 DISCUSSION

Several previous research efforts in the Altamont WRA have demonstrated an inordinately high raptor mortality resulting from the facility's use by relatively large numbers of these species (Orloff and Flannery 1992, 1996; Hunt 1997). Orloff and Flannery (1996) conservatively estimated that 39 golden eagles were killed during each year of their study throughout the entire Altamont WRA. The California Department of Fish and Game has designated golden eagles as a Species of Special Concern in California. In addition, they receive special protection under the federal Bald Eagle Protection Act.

It has long been known that golden eagles are relatively common in the central Coast Ranges of California (Carnie 1954; Thelander 1974). Recent population studies conducted for NREL by the Predatory Bird Research Group at the University of California, Santa Cruz, show that golden eagles nest in extraordinary numbers throughout the region, and immediately adjacent to the Altamont WRA. Also, many winter migrants pass through the area each year (Hunt 1994, 1997). The relatively new phenomenon of having approximately 5,000 operating wind turbines dominating the landscape has had a demonstrable impact on the region's raptors. Studies are under way to determine the long-term effects of these increased fatalities on the viability of the region's golden eagles (see Hunt 1998; Hunt 1999).

Regardless of the outcome of Hunt's population studies, it is prudent to determine what behavioral factors might contribute to increased risk when individual birds encounter wind turbines. By doing so, we believe it may be possible to significantly reduce bird fatalities where facilities already are installed. Also, such information may assist in predicting whether or not proposed facility designs, modification, or new turbine tower placements will change the risk to birds. Clearly, without this fundamental information, resource managers and turbine facility operators can only speculate on the effectiveness of measures already taken, or being considered, that might reduce the frequency of bird fatalities.

Raptors comprise a significant portion of all recorded bird fatalities in the Altamont WRA (Orloff and Flannery 1992, 1996; Howell 1997; Howell and DiDonato 1991). Howell and DiDonato (1991) reported 17 raptor fatalities. They calculated a mortality rate of 0.05 deaths/turbine/year. In a subsequent study, Howell (1997) identified 72 confirmed fatalities during 18 months in the Altamont WRA. Bird fatalities consisted of 44 raptors and 28 non-raptors, with a mean raptor mortality rate of 0.03 bird/turbine/year.

Our fatality data collected during an 11-month period (April - February) at 414 turbine towers indicates a mortality rate of 0.15 bird deaths/turbine/year. For raptor species (including owls), there were approximately 0.06 deaths/turbine/year. There are no horizontal lattice facilities in our sample. Despite the difference in the type of facilities being sampled in our study, our preliminary estimate of raptor mortality is similar to that reported by Howell and DiDonato (1991) and nearly twice the fatality rate reported by Howell (1997).

Orloff and Flannery (1992) reported that raptor species accounted for 119 (65%) of 182 dead birds they found. In their 1996 study, raptor mortality varied from 0.02 to 0.05 deaths/turbine/year. These rates also are lower than those indicated by our data. The possible reasons for these discrepancies will be explored in the final report.

According to Orloff and Flannery (1992) and (1996), the predominant species killed were red-tailed hawks, American kestrels, and golden eagles. They also reported turkey vultures, various owl species, and common ravens. This is similar to what we found. In the former studies, the relative abundance of the five most common species being struck by wind turbines was disproportionate to their frequency of fatality. Golden eagles, red-tailed hawks, and American kestrels were killed more frequently than were

turkey vultures and common ravens, even though the latter two species are more abundant in the Altamont WRA. Our data confirm that the relative abundance of species does not predict the relative frequency of fatalities per species. Some species are apparently more susceptible than others to the risks posed by wind turbines, assuming carcass detection probabilities are equal per species.

Orloff and Flannery (1996) suggested that birds, especially raptors, might not be able to visually detect the rotating blades in their field of view. For example, raptors may not see the blades in the foreground of their field of vision while focused on prey they are pursuing. This has led to speculation that bird fatalities may be reduced if the turbine towers are modified to discourage perching. Several techniques are being considered, including painting disruptive patterns on turbine blades (KENETECH 1996, unpublished report), implementing sound devices to scare off birds, covering the bases of turbine rotors to discourage perching, and modifying the spacing between turbines to reduce bird collision (Hunt 1994). This line of research has yet to yield promising results.

Some researchers suggest that turbines placed near gullies and turbines that are at the ends of strings pose a higher risk to birds (Hunt 1994; Orloff and Flannery 1992, 1996). Turbines with the highest operating times may be more likely to be involved in bird fatalities (Orloff and Flannery 1996). The latter observation also relates to the time of year, because wind turbine operation varies from month to month. Our findings indicate that, at least in our study plots, there may be no significant difference between the frequency of fatalities associated with turbines at the ends of turbine strings compared to those within the turbine strings. Other factors such as prey availability and topographic features may have a confounding effect on this preliminary assessment. We intend to explore these relationships in our final analysis and in conjunction with our GPS/GIS data.

The present research project points out, in part, the need for accurate assessments of the true extent of bird fatalities in the Altamont WRA. Prior to our research project, no valid sampling procedures were used that provided a suitably accurate estimate of bird kills. While the WRRS database reportedly contains records for a large number of bird fatalities, we intend to examine the efficacy of using it as a monitoring tool as suggested by Curry and Kerlinger (1998) and the Alameda County Community Development Agency (1998). Until a suitable monitoring method is designed and tested, only comprehensive fatality searches should be relied upon for assessing the true extent of bird fatalities and for assessing the effectiveness of management efforts intended to reduce bird fatalities.

Orloff and Flannery (1992) suggested that birds use certain types of turbine towers as perches more often than other available perches. This potentially increases the chances of turbine-related fatalities because of the bird's frequent proximity to the blades. In their comparative analysis of mortality between five turbine types (i.e., lattice towers, horizontal cross, vertical axis, guyed pipe, and tubular), Orloff and Flannery (1992) concluded that bird mortality was significantly higher at lattice-tower turbines than at any other type. They suggested that the principal features of lattice towers that may contribute to the higher mortality rate include: (1) a multitude of potential raptor perch sites on the horizontal reinforcing crossbars, (2) a high percentage of time in operation, and (3) their relatively high tip speed.

In our study plots, 50% of all turbines included in the fatality searches are on tubular towers. To date, our findings indicate that 57% of all bird fatalities are associated with tubular towers. This finding is significant because there are no horizontal lattice turbine towers in our sample of fatality searches. This difference implies that tubular towers may represent as significant a risk to birds as do horizontal-lattice turbine towers. If this is true, there may be little advantage derived in terms of reduced bird fatalities by replacing horizontal-lattice turbine towers with tubular turbine towers. We will examine this point more fully in the final report.

A relatively large number of bird species (and individuals) are represented in our fatality data. The species diversity alone serves to highlight the fact that there is a wide spectrum of flight and perching behaviors that occur near wind turbines. For example, four burrowing owl fatalities were recorded. This species is declining rapidly over much of its range, and it spends much of its time on or near the ground. In contrast, a prairie falcon was killed in February. This is a highly aerial predator that is seen relatively infrequently in the area. With so many species involved, each employing very different flight strategies, the underlying risk factors associated with wind turbines vary greatly from species to species. Finding universal management solutions that will address the many bird species and flight strategies present in the Altamont WRA continues to be a perplexing conservation objective.

7.0 TABLES AND FIGURES

Table 1. The Number of Towers in each of 20 study plots in the Altamont WRA (n= 785). Behavioral observations were recorded at 685 of these.

Plot No.	Tubular Bonus	Tubular Danwind	Tubular SeaWest (*)	Diagonal Lattice	Horizontal Lattice (*)	Vertical Axis	No. Towers Observed ¹	No. Towers Searched ²	Total No. in Plot
1	33	0	0	0	0	25	58	58	58
2	25	0	0	0	0	6	31	31	31
3	29	0	0	0	0	9	38	38	38
4	24	0	0	0	0	12	36	36	36
5	14	0	0	0	32	0	46	14	46
6	27	0	0	0	34	0	61	27	61
7	39	0	0	0	0	0	39	39	39
8	25	0	0	0	0	0	25	25	25
9	39	0	0	0	0	0	39	39	39
10	15	0	0	0	0	0	15	15	15
11	5	0	24	0	10	20	59	25	59
12	16	7	0	0	0	21	44	44	44
13	0	0	0	0	0	46	46	46	46
14	14	10	0	0	0	0	24	24	24
15	14	0	0	12	0	0	26	26	26
16	6	4	0	45	0	0	55	55	55
17	0	0	0	42	0	0	42	42	42
18	0	0	0	41	0	0	41	41	41
19	0	0	0	24	0	0	24	24	24
20	0	0	0	36	0	0	36	36	36
Total:	325	21	24	200	76	139	785	685	785

¹ Number of towers included in the 30-minute point counts for behavioral observations.

² Number of towers included in the fatality searches.

Table 2. Summary of All Bird Observations (n= 2,186) recorded from March 1998 through February 1999 in 20 Study Plots (n= 745 30-minute point counts) in the Altamont WRA. The species are arranged by order of frequency of observation.

Species	Mar	Apr	May	June	July	Aug	Sept	Oct	Nov	Dec	Jan	Feb	Totals
Red-tailed Hawk <i>Buteo jamaicensis</i>	3	14	11	19	14	13	21	51	77	73	45	98	439
Common Raven <i>Corvus corax</i>	1	34	21	38	20	3	15	36	27	49	29	65	338
Turkey Vulture <i>Cathartes aura</i>	0	11	18	41	43	25	36	31	18	19	7	23	272
Golden Eagle <i>Aquila chrysaetos</i>	1	18	25	62	38	25	29	14	5	12	5	15	249
California Gull <i>L. californicus</i>	2	21	9	0	0	0	5	28	37	12	11	3	128
Ring-billed Gull <i>Larus delawarensis</i>	0	0	0	0	0	0	0	0	11	32	23	26	92
Rock Dove <i>Columba livia</i>	1	19	21	10	9	2	3	2	2	5	16	1	91
American Kestrel <i>Falco sparverius</i>	1	5	7	6	8	3	9	2	4	8	7	13	73
Icterid spp.	0	0	0	5	1	1	3	7	2	9	8	16	52
Red-winged Blackbird <i>Agelaius phoeniceus</i>	1	3	1	3	0	0	4	2	0	5	14	17	50
Western Meadowlark <i>Sturnella negeta</i>	0	8	11	14	1	0	0	0	2	2	3	2	43
Brewer's Blackbird <i>Euphagus cyanocephalus</i>	0	0	0	6	1	2	2	9	3	3	4	4	34
Raptor spp.	0	1	2	3	5	0	1	9	2	2	4	4	33
American Crow <i>Corvus brachyrhynchos</i>	0	10	2	5	3	0	6	4	0	1	0	0	31
Tricolored Blackbird <i>Agelaius tricolor</i>	0	0	3	18	5	0	1	0	0	0	0	2	29
Loggerhead Shrike <i>Lanius ludovicianus</i>	0	3	8	3	1	0	1	1	1	0	2	5	25
Prairie Falcon <i>Falco mexicanus</i>	0	0	0	2	4	0	7	6	1	0	2	2	24
Violet-green Swallow <i>Tachycineta thalassina</i>	0	0	1	16	5	1	0	0	0	1	0	0	24
Northern Harrier <i>Circus cyaneus</i>	0	2	1	4	1	1	1	2	1	0	3	5	21
House Finch <i>Carpodacus mexicanus</i>	1	1	0	1	0	0	0	2	5	2	2	6	20
Passerine spp.	0	0	0	1	0	0	0	2	5	2	6	4	20
Mallard <i>Anas platyrhynchos</i>	0	2	4	6	1	1	0	0	0	0	1	2	17
Horned Lark <i>Eremophila alpestris</i>	0	3	1	1	0	0	0	2	3	0	0	3	13
Mountain Bluebird <i>Sialia currucoides</i>	0	0	0	0	0	0	0	0	1	2	3	3	9
Burrowing Owl <i>Athene cunicularia</i>	0	2	1	3	1	1	0	0	0	0	0	0	8
Waterfowl spp.	0	0	0	5	1	1	0	0	0	0	1	0	8
Water Pipit <i>Anthus spinoletta</i>	0	0	0	0	0	0	0	0	0	2	0	5	7
European Starling <i>Sturnus vulgaris</i>	0	0	2	0	0	0	0	0	0	0	1	3	6

Table 2. Summary of All Bird Observations (n= 2,186) recorded from March 1998 through February 1999 in 20 Study Plots (n= 745 30-minute point counts) in the Altamont WRA. The species are arranged by order of frequency of observation (concluded).

Species	Mar	Apr	May	June	July	Aug	Sept	Oct	Nov	Dec	Jan	Feb	Totals
Mourning Dove <i>Zenaida macroura</i>	0	1	3	0	0	0	0	0	0	0	1	0	5
Western Kingbird <i>Tyranus verticalis</i>	0	0	0	0	2	0	0	0	0	0	0	3	5
Caspian Tern <i>Sterna caspia</i>	0	0	2	2	0	0	0	0	0	0	0	0	4
Ferruginous Hawk <i>Buteo regalis</i>	0	0	0	0	0	0	3	0	0	1	0	0	4
Northern Flicker <i>Colaptes auratus</i>	0	0	0	0	0	0	0	0	0	1	2	0	3
Savannah Sparrow <i>Passerculus sandwichensis</i>	0	0	0	0	0	0	0	0	0	0	3	0	3
Barn Swallow <i>Hirundo rustica</i>	0	0	1	0	1	0	0	0	0	0	0	0	2
Sharp-shinned Hawk <i>Accipiter striatus</i>	0	0	0	0	0	0	0	0	0	0	1	0	1
Rough-legged Hawk <i>Buteo lagopus</i>	0	0	0	0	0	0	0	0	0	0	1	0	1
Tree Swallow <i>Tachycineta bicolor</i>	0	0	0	1	0	0	0	0	0	0	0	0	1
Hooded Oriole <i>Icterus cuculatus</i>	0	0	0	1	0	0	0	0	0	0	0	0	1
TOTALS:	11	158	155	276	165	79	147	210	207	243	205	330	2,186
No. of 30-minute point counts	2	50	45	108	109	59	70	81	44	61	42	74	745

Table 3. Summary of All Bird Observations by Tower Type from March 1998 through February 1999 in 20 Study Plots in the Altamont WRA. For Flying Observations, the Data are Separated into 25-meter Increments Ranging from 1-100 Meters from the Nearest Turbine.

Tubular/Bonus	1998											1999		Total
	Mar	Apr	May	June	July	Aug	Sept	Oct	Nov	Dec	Jan	Feb		
Perching	3	11	9	10	8	7	15	28	34	62	38	54	279	
Flying	5	86	84	156	81	40	70	102	95	83	97	121	1,020	
Totals	8	97	93	166	89	47	85	130	129	145	135	175	1,299	

Distance

1-25 m	2	22	34	38	16	10	23	31	27	27	16	25	271
26-50 m	2	20	13	25	17	8	15	28	32	16	22	32	230
51-75 m	0	6	8	22	10	6	11	15	7	8	30	26	149
75-100 m	1	20	9	20	18	4	14	21	22	11	15	14	169
> 100 m	0	18	20	51	20	12	7	7	7	21	14	24	201

Vertical Axis

Perching	1	6	8	10	4	7	9	14	17	12	14	22	124
Flying	2	25	32	49	37	17	30	40	31	30	26	51	370
Total	3	31	40	59	41	24	39	54	48	42	40	73	494

Distance

1-25 m	1	3	10	12	9	8	11	9	10	8	11	8	100
26-50 m	0	5	3	8	10	4	10	14	11	7	5	16	93
51-75 m	0	6	6	8	5	4	1	8	7	12	6	10	73
75-100 m	0	3	5	6	11	1	6	3	2	3	1	5	46
> 100 m	1	8	8	15	2	0	2	6	1	0	3	12	58

Diagonal Lattice

Perching	0	0	0	4	0	0	1	4	0	6	4	8	27
Flying	0	0	7	11	9	1	9	15	16	14	7	38	127
Total	0	0	7	15	9	1	10	19	16	20	11	46	154

Distance

1-25 m	0	0	3	6	1	0	5	3	9	2	0	11	40
26-50 m	0	0	3	2	2	0	2	6	5	5	1	6	32
51-75 m	0	0	1	1	3	0	1	2	1	3	3	13	28
75-100 m	0	0	0	1	0	0	2	4	1	2	2	5	17
> 100 m	0	0	0	1	3	1	0	0	0	1	1	3	10

Horizontal Lattice

Perching	0	9	1	6	2	0	1	1	3	5	1	7	36
Flying	0	16	10	23	17	5	10	5	6	10	11	15	128
Total	0	25	11	29	19	5	11	6	9	15	12	22	164

Distance

1-25 m	0	7	6	7	4	0	4	0	3	3	0	4	38
26-50 m	0	2	2	6	3	1	3	2	1	1	2	7	30
51-75 m	0	5	1	2	0	1	1	1	1	4	6	2	24
75-100 m	0	2	0	5	3	1	2	1	0	1	2	1	18
> 100 m	0	0	1	3	7	2	1	1	1	1	1	0	18

Table 3. Summary of All Bird Observations by Tower Type from March 1998 through February 1999 in 20 Study Plots in the Altamont WRA. For Flying Observations, the Data are Separated into 25-meter Increments Ranging from 1-100 Meters from the Nearest Turbine (concluded).

Tubular/SeaWest	1998											1999		Total
	Mar	Apr	May	June	July	Aug	Sept	Oct	Nov	Dec	Jan	Feb		
Perching	0	0	1	1	0	0	0	0	0	3	0	0	5	
Flying	0	1	3	5	1	1	0	1	2	6	2	4	26	
Total	0	1	4	6	1	1	0	1	2	9	2	4	31	
Distance														
1-25 m	0	0	0	1	0	0	0	0	1	0	1	0	3	
26-50 m	0	1	2	0	0	1	0	0	0	2	0	1	7	
51-75 m	0	0	1	1	0	0	0	1	1	2	0	1	7	
75-100 m	0	0	0	2	1	0	0	0	0	1	0	2	6	
> 100 m	0	0	0	1	0	0	0	0	0	1	1	0	3	
Tubular/Danwin														
Perching	0	1	0	0	1	0	0	1	1	4	2	3	13	
Flying	0	3	0	1	5	1	2	0	2	8	3	6	31	
Total	0	4	0	1	6	1	2	1	3	12	5	9	44	
Distance														
1-25 m	0	1	0	0	0	1	0	0	0	2	1	1	6	
26-50 m	0	1	0	1	3	0	0	0	0	2	0	1	8	
51-75 m	0	0	0	0	1	0	1	0	1	1	0	3	7	
75-100 m	0	1	0	0	1	0	1	0	1	1	2	1	8	
> 100 m	0	0	0	0	0	0	0	0	0	2	0	0	2	
TOTALS	11	158	155	276	165	79	147	211	207	243	205	329	2,186	

Table 4. Summary of Fatalities Recorded (n= 96) from April 1998 through February 1999 in the Altamont WRA. The Data for November through February Separate the Original 414 Tower Samples from those Added into the Study in November 1998.

Month	April	May	June	July	Aug	Sept	Oct	Nov	Dec	Jan	Feb	Total
No. Sampling Events	1	1	1	1	1	1	1	1	1	1	1	12
No. of turbines visited	414	414	414	414	414	414	414	414	271	414	271	
Mallard <i>Anas platyrhynchos</i>		1										1
California Gull <i>Larus californicus</i>				1								1
Golden Eagle <i>Aquila chrysaetos</i>			2	1		1						4
Red-tailed Hawk <i>Buteo jamaicensis</i>		2	1	1	2		3	3		3	2	19
American Kestrel <i>Falco sparverius</i>		1	1					1			1	4
Prairie Falcon <i>Falco mexicanus</i>											1	1
Rock Dove <i>Columba livia</i>			2	4	1			2		1	3	15
Mourning Dove <i>Zenaida macroura</i>			1									1
Barn Owl <i>Tyto alba</i>			1	1							2	4
Burrowing Owl <i>Athene cunicularia</i>				1		2	1					4
Horned Lark <i>Eremophila alpestris</i>				3	1	1						5
Cliff Swallow <i>Hirundo pyrrhonota</i>					1	1						2
European Starling <i>Sturnus vulgaris</i>			1			1				2		4
Western Meadowlark <i>Sturnella negecta</i>				1	1	1			1	1	2	8
Black-throated Gray Warbler <i>Dendroica nigrescens</i>				0		1						1
Towson's Warbler <i>Dendroica towsoni</i>						1						1
Raptor spp.							1					1
Old Raptor Carcass (*)							1	1		4	4	12
Passerine spp.			1			1				1	1	6
Icterid spp.				1								1
No. Bird Fatalities	0	4	10	14	6	10	6	0	7	1	0	95
Hoary Bat <i>Lasiurus cinereus</i>						1						1
Total Fatalities	0	4	10	14	6	11	6	0	7	1	0	96

*These raptor remains are believed to be at least 6 - 12 months old.

Table 5. Summary of All Fatalities Recorded by Tower Type in the Altamont WRA.

	Tubular (Bonus)	Tubular (Danwin)	Vertical Axis	Diagonal Lattice	Total
No. of Turbines	325	21	139	200	685
Raptor	29	0	1	19	49
Non-Raptor	25	0	9	12	37
Bird Fatalities:	54	0	10	31	95
Mammal	1	0	0	0	1
Total Fatalities:	55	0	10	31	96

Horizontal Lattice



Tubular Bonus

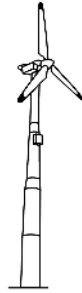

Vertical Axis

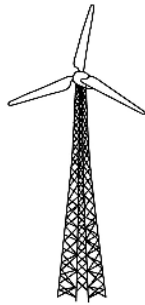
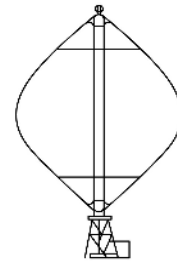

Diagonal Lattice

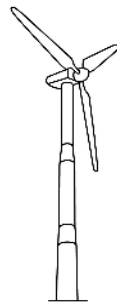

Tubular Darwin



Tubular SeaWest

Figure 1. Turbine tower types represented in the project study plots in the Altamont WRA.

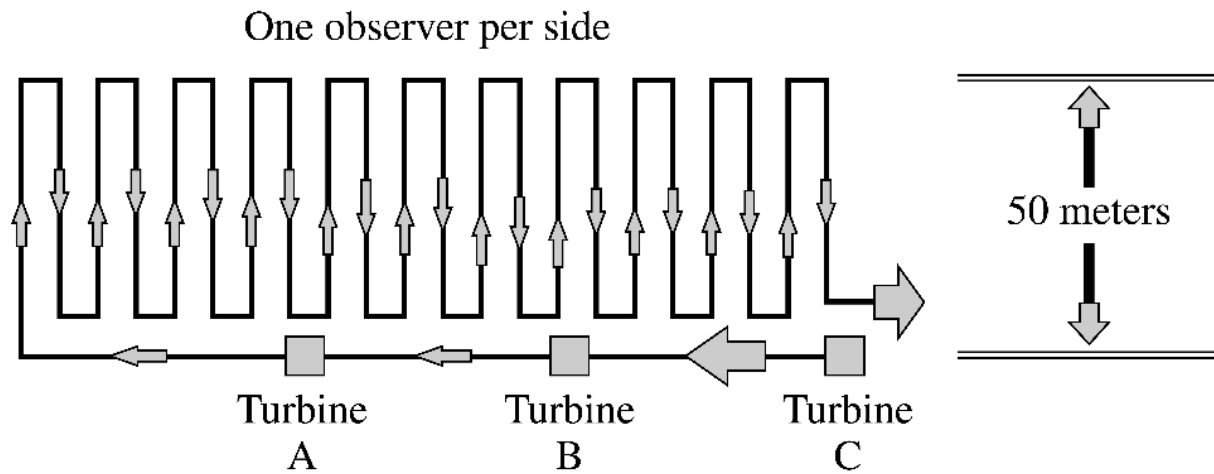

Figure 2a. Illustration of the zigzag survey route used for fatality searches on relatively level terrain in the Altamont WRA. One observer per side walks the route indicated by the arrows.

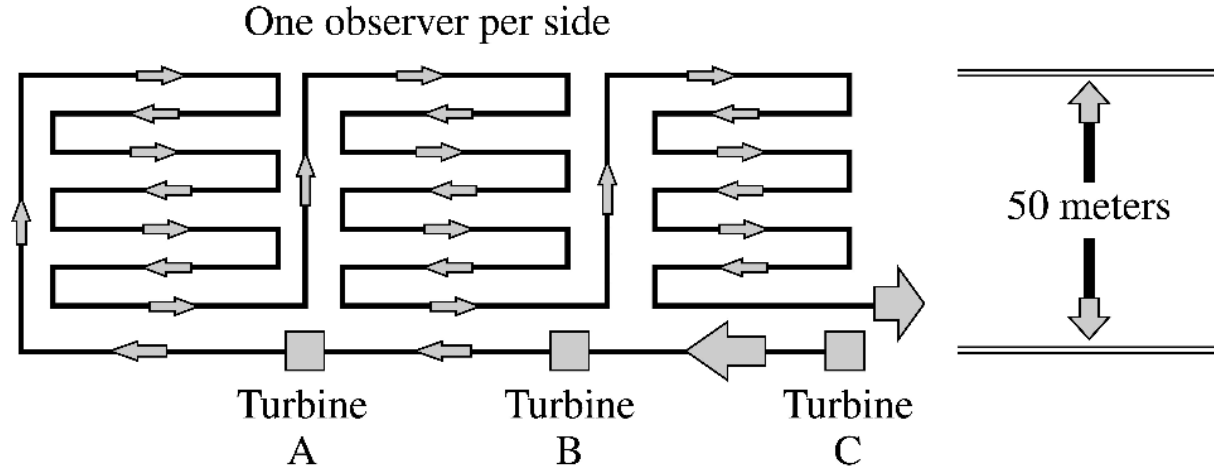

Figure 2b. Illustration of the zigzag survey route used for fatality searches on relatively steep terrain in the Altamont WRA. One observer per side walks the route indicated by the arrows.

8.0 ACKNOWLEDGEMENTS

This project was funded by the National Renewable Energy Laboratory and managed by NREL's Karin Sinclair. Michael L. Morrison, Ph.D., has provided valuable insights and guidance in all phases of the project. Field biologists who have participated include Lourdes Ruge (Field Team Leader), Stacia Hoover, James Cain, Cherilyn Burton, and Elizabeth van Mantgen. We especially thank the management of ENRON, FORAS, and Altamont Wind Power for providing access to the wind facilities they own and/or operate. The authors thank Hap Boyd of ENRON; Richard Curry, Paul Kerlinger, and Joanie Stewart of FPL; plus, three anonymous reviewers for their comments on this report.

9.0 REFERENCES

Alameda County Community Development Agency (1998). The EIR for Repowering a Portion of the Altamont Pass Wind Resource Area. Appendix E, Repowering Program/Biological Resources Management Plan. State Clearinghouse Document No. 98022024. 2 Volumes.

Anderson, R.L.; Tom, J.; Neuman, N.; Noone, J.; Maul, D. (1996). *Avian Risk Assessment Methodology. Proceedings of National Avian-Wind Power Planning Meeting II; Palm Springs, California; September 20 - 22, 1995*; Prepared for the Avian Subcommittee of the National Wind Coordination Committee by RESOLVE, Inc., Washington, DC, and LGL Ltd., King City, Ontario; 152 pp.

Block, W.M.; K.A. With; M.L. Morrison (1987). "On Measuring Bird Habitat Observer Variability and Sample Size." *Condor* 89:pp.241 - 251.

Carnie, K. (1954). "Food Habits of Nesting Golden Eagles in the Coast Ranges of California." *Condor* 56:pp.3 - 12.

Curry, R.C.; Kerlinger P. (1998). "Avian Mitigation Plan. KENETECH Model Wind Turbines, Altamont Pass WRA, CA." Prepared for the Utility Wind Interest Group, Cheyenne, Wyoming.

Gauthreaux, S.A. (1996). "Suggested Practices for Monitoring Bird Populations, Movements and Mortality in Wind Resource Areas." *Proceedings of National Avian-Wind Power Planning Meeting II. Palm Springs, California; September 20 - 22, 1995*; Prepared for the Avian Subcommittee of the National Wind Coordination Committee by RESOLVE, Inc., Washington, DC, and LGL Ltd., King City, Ontario; 152 pp.

Howell, J.A. (1997). "Avian Mortality at Rotor Swept Area Equivalents, Altamont Pass and Montezuma Hills, California." *Transactions of the Western Section of the Wildlife Society* 33:pp.24-29.

Howell, J.A. and DiDonato, J.E. (1991). *Assessment of Avian Use and Mortality Related to Wind Turbine Operations, Altamont Pass, Alameda and Contra Costa Counties, California, September 1988 through August 1989*. Final Report. Prepared for U.S. Windpower, Inc., Livermore, California; 168 pp.

Hunt, G. (1994). *A Pilot Golden Eagle Population Study in the Altamont Pass Wind Resource Area, California*. Prepared by the Predatory Bird Research Group, University of California, Santa Cruz, for the National Renewable Energy Laboratory, Golden, Colorado; 212 pp. NREL/TP-441-7821.

Hunt, G. (1997). *A Population Study of Golden Eagles in the Altamont Pass Wind Resource Area: Second-Year Progress Report*. Prepared by Predatory Bird Research Group, Santa Cruz, California, for the National Renewable Energy Laboratory, Golden, Colorado; 98 pp. NREL/SR-440-23087.

Hunt, G. (1998). "Raptor Floaters at Moffat's Equilibrium." *Oikos* 82(1); pp.191-197.

Hunt, W.G.; Jackman, R.E.; Hunt, T.L.; Driscoll, D.E.; Culp, L. (1999). *A Population Study of Golden Eagles in the Altamont Pass Wind Resource Area: Population Trend Analysis 1994 – 1997*. Report to National Renewable Energy Laboratory, Subcontract XAT-6-16459-01. Predatory Bird Research Group, University of California, Santa Cruz; 33pp. NREL/SR-500-26092.

Kerlinger, P.; Curry, R. (1997). *Analysis of Golden Eagle and Red-tailed Hawk Fatalities at KENETECH Windpower's Altamont Wind Resource Area (WRA)*. Unpublished status report on the Altamont Avian Plan to the U.S. Fish and Wildlife Service and KENETECH, Inc., Livermore, CA.

Morrison, M. L.; Davis, H. (1996). *Protocols for Evaluation of Existing Wind Developments and Determination of Bird Mortality*. Proceedings of National Avian-Wind Power Planning Meeting II. September 20 – 22, 1995; Palm Springs, California. Prepared for the Avian Subcommittee of the National Wind Coordination Committee by RESOLVE, Inc., Washington, D.C., and LGL Ltd., King City, Ontario; 152 pp.

Morrison, M.L.; Pollock, K.H. (1997). *Development of a Practical Modeling Framework for Estimating the Impact of Wind Technology on Bird Populations*. National Renewable Energy Laboratory, Golden, Colorado. Work performed by California State University, Sacramento, California and North Carolina State University, Raleigh, North Carolina. NREL/SR-440-23088.

Morrison, M. L.; Sinclair, K.C. (1997). *Overview of the U.S. Department of Energy/National Renewable Energy Laboratory Avian Research Program*. Presented at the Windpower '97 Conference in Austin, Texas, June 1997; 9 pp. NREL/CP-440-23115.

Orloff, S., and Flannery, A. (1992). *Wind Turbine Effects on Avian Activity, Habitat Use, and Mortality in Altamont Pass and Solano County Wind Resource Areas*. Prepared by BioSystems Analysis, Inc., Tiburon, California, for the California Energy Commission, Sacramento.

Orloff, S.; Flannery, A. (1996). *A Continued Examination of Avian Mortality in the Altamont Pass Wind Resource Area*. Prepared by BioSystems Analysis, Inc., Tiburon, California, for the California Energy Commission, Sacramento; 48 pp.

Reynolds, R.T.; Scott, J.M.; Nussbaum, R.A. (1980). "A Variable Circular-Plot Method for Estimating Bird Numbers." *Condor* 82:pp.309-313.

Thelander, C. G. (1974). "Nesting Territory Utilization by Golden Eagles (*Aquila chrysaetos*) in California During 1974." Admin. Report No. 74-7, California Department of Fish and Game, Wildlife Management Branch, Sacramento California. Project No. W-54-R-6, 22 pp.

Walcott, C. (1995). "Tilting at Windmills." *Living Bird* 95(2);pp.11-16.

REPORT DOCUMENTATION PAGE			Form Approved OMB NO. 0704-0188	
Public reporting burden for this collection of information is estimated to average 1 hour per response, including the time for reviewing instructions, searching existing data sources, gathering and maintaining the data needed, and completing and reviewing the collection of information. Send comments regarding this burden estimate or any other aspect of this collection of information, including suggestions for reducing this burden, to Washington Headquarters Services, Directorate for Information Operations and Reports, 1215 Jefferson Davis Highway, Suite 1204, Arlington, VA 22202-4302, and to the Office of Management and Budget, Paperwork Reduction Project (0704-0188), Washington, DC 20503.				
1. AGENCY USE ONLY (Leave blank)	2. REPORT DATE May 2000	3. REPORT TYPE AND DATES COVERED Subcontract Report - March 1998 to February 1999		
4. TITLE AND SUBTITLE Avian Risk Behavior and Fatalities at the Altamont Wind Resource Area			5. FUNDING NUMBERS C: TAT-8-18209-01 TA: WE00.1910	
6. AUTHOR(S) Carl G. Thelander and Lourdes Ruggie				
7. PERFORMING ORGANIZATION NAME(S) AND ADDRESS(ES) BioResource Consultants P.O. Box 1539 Ojai, California 93024			8. PERFORMING ORGANIZATION REPORT NUMBER	
9. SPONSORING/MONITORING AGENCY NAME(S) AND ADDRESS(ES) National Renewable Energy Laboratory 1617 Cole Blvd. Golden, CO 80401-3393			10. SPONSORING/MONITORING AGENCY REPORT NUMBER NREL/SR-500-27545	
11. SUPPLEMENTARY NOTES NREL Technical Monitor: Karin Sinclair				
12a. DISTRIBUTION/AVAILABILITY STATEMENT National Technical Information Service U.S. Department of Commerce 5285 Port Royal Road Springfield, VA 22161			12b. DISTRIBUTION CODE	
13. ABSTRACT (<i>Maximum 200 words</i>) Since 1981, more than 7,000 wind turbines have been installed in the Altamont Wind Resource Area in north-central California. Currently, about 5,000 turbines are operating. Past research efforts demonstrated that wind turbines frequently kill birds, especially raptors. Little is known about the specific flight and perching behaviors by birds near wind turbines. A better understanding of these interactions may one day yield insights on how to minimize bird fatalities. This Phase I progress report summarizes research findings obtained at 20 study plots totaling 785 turbines of various configurations and conducted between March 1998 and February 1999. We examined bird use and behaviors and collected data on fatalities at the same turbines throughout the course of our surveys. We completed 745 30-minute point counts (1,702 bird observations) that quantified bird risk behaviors and bird use of the study plots. The four most frequently observed bird species were red-tailed hawks, common ravens, turkey vultures, and golden eagles. During the same period, we recorded 95 bird fatalities. Raptors represent 51% (n=49) of the kills found. The data indicate that the relative abundance of species observed does not predict the relative frequency of fatalities per species. Phase II of the research is underway.				
14. SUBJECT TERMS Wind turbines; Altamont Wind Resource Area; avian fatalities; raptors; risk behavior			15. NUMBER OF PAGES	
			16. PRICE CODE	
17. SECURITY CLASSIFICATION OF REPORT Unclassified	18. SECURITY CLASSIFICATION OF THIS PAGE Unclassified	19. SECURITY CLASSIFICATION OF ABSTRACT Unclassified	20. LIMITATION OF ABSTRACT UL	