

UC Berkeley

Controls and Information Technology

Title

Balancing comfort: occupants' control of window blinds in private offices

Permalink

<https://escholarship.org/uc/item/3rd2f2bg>

Author

Inkarojrit, Vorpat

Publication Date

2005-10-01

Peer reviewed

Balancing Comfort: Occupants' Control of Window Blinds in Private Offices

by

Vorapat Inkarojrit

B.Arch (Chulalongkorn University, Thailand) 1996

M.Arch (University of Washington, Seattle) 1999

A dissertation submitted in partial satisfaction of the

requirements for the degree of

Doctor of Philosophy

in

Architecture

in the

GRADUATE DIVISION

of the

UNIVERSITY OF CALIFORNIA, BERKELEY

Committee in charge:

Professor Charles C. Benton, Chair

Professor Edward A. Arens

Professor Thomas D. Wickens

Professor Stephen E. Palmer

Fall 2005

The dissertation of Vorapat Inkarojrit is approved:

	<i>Charles C. Benton</i>	<i>6/8/05</i>
Chair		Date
	<i>Chue Jen</i>	<i>6/7/05</i>
		Date
	<i>Ken</i>	<i>6/8/05</i>
		Date
	<i>Stephen E. Parker</i>	<i>6/7/05</i>
		Date

University of California, Berkeley

Fall 2005

Balancing Comfort: Occupants' Control of Window Blinds in Private Offices

© 2005

by

Vorapat Inkarojrit

Abstract

Balancing comfort: Occupants' control of window blinds in private offices

by

Vorapat Inkarojrit

Doctor of Philosophy in Architecture

University of California, Berkeley

Professor Charles C. Benton, Chair

The goal of this study was to develop predictive models of window blind control that could be used as a function in energy simulation programs and provide the basis for the development of future automated shading systems. Toward this goal, a two-part study, consisting of a window blind usage survey and a field study, was conducted in Berkeley, California, USA, during a period spanning from the vernal equinox to window solstice. A total of one hundred and thirteen office building occupants participated in the survey. Twenty-five occupants participated in the field study, in which measurements of physical environmental conditions were cross-linked to the participants' assessment of visual and thermal comfort sensations.

Results from the survey showed that the primary window blind closing reason was to reduce glare from sunlight and bright windows. For the field study, a total of thirteen predictive window blind control logistic models were derived using the Generalized Estimating Equations (GEE) technique.

As hypothesized, the probability of a window blind closing event increased as the magnitude of physical environmental and confounding factors increased. The main predictors were maximum window luminance, average window luminance, background luminance and vertical solar radiation at the window. The confounding factors included Mean Radiant Temperature (MRT), direct solar penetration, and participants' self-reported sensitivity to brightness. The results showed that the models correctly predict between 73 – 89 % of the observed window blind control behavior.

The field study also examined a new method for assessing the visual comfort sensation from daylight using a digital luminance map. Sensation of discomfort glare from daylight was moderately correlated with simple luminance-based variables captured from the luminance maps, suggesting that these variables could be used as discomfort glare predictors as an alternative to the existing Daylight Glare Index.

This dissertation extends the knowledge of how and why building occupants manually control window blinds in private offices, and provides results that can be directly implemented in energy simulation programs. This study concludes that future work is needed to develop control algorithms that maintain satisfaction while allowing the energy-saving potential of automated shading systems to be fully realized.

Charles C. Benton

6/8/05

Chair

Date

TABLE OF CONTENTS

TABLE OF CONTENTS.....	i
LIST OF FIGURES.....	v
LIST OF TABLES.....	xi
ACKNOWLEDGEMENTS.....	xiii

CHAPTER 1: INTRODUCTION

1.1	Background.....	1
1.2	Problem statement.....	2
1.3	Objectives.....	3
1.4	Hypotheses.....	4
1.5	Scope and limitations.....	5
1.6	Approach.....	6
1.7	Organization of the dissertation.....	8

CHAPTER 2: LITERATURE REVIEW

2.1	Concept of comfort.....	9
	2.1.1 Providing physical comfort: Environmental control systems.....	10
	2.1.2 Beyond physical comfort: Adaptive comfort model.....	13
	2.1.3 Restoring comfort: Window blind control as adaptive behavior.....	15
2.2	Venetian blinds.....	17
	2.2.1 Brief history of Venetian blinds.....	18
	2.2.2 Physical properties of Venetian blinds.....	18
	2.2.2.1 Optical properties.....	19
	2.2.2.2 Thermal properties.....	22
2.3	Previous studies on the control of window blinds.....	24
	2.3.1 Monitoring of window blind usage.....	24
	2.3.2 Subjective responses to window blinds.....	31
	2.3.3 Other potential factors.....	32
	2.3.3.1 Visual privacy and visual exposure.....	32
	2.3.3.2 View and access to environmental information.....	33
	2.3.3.3 Daylight, sunlight, satisfaction and productivity.....	34
	2.3.3.4 Effect of long-term exposure.....	35
	2.3.3.5 Age and gender.....	35
	2.3.3.6 Contextual influences.....	36
	2.3.3.7 Effect of task viewing position on glare.....	37
	2.3.3.8 Interaction effects.....	37
	2.3.4 Existing window blind control algorithms.....	39
2.4	Gaps in the literature.....	43

CHAPTER 3: RESEARCH METHODS

3.1	Introduction.....	45
3.2	Study variables.....	46
3.2.1	Window blind movement.....	48
3.2.2	Visual comfort.....	48
3.2.3	Luminance ratio.....	58
3.2.4	Thermal comfort.....	64
3.2.5	Subjective variables.....	65
3.2.5.1	Visual comfort sensation.....	66
3.2.5.2	Thermal comfort sensation.....	67
3.2.5.3	Sensitivity to brightness and temperature.....	68
3.2.6	Workplane illuminance.....	68
3.2.7	Vertical solar radiation at window.....	69
3.2.8	Confounding factors.....	69
3.3	Instruments.....	70
3.3.1	Window blind movement: Electronic sensors.....	70
3.3.2	Window blind movement: Time-lapse photography.....	74
3.3.3	Luminance characteristics: Digital luminance map.....	74
3.3.3.1	Background.....	74
3.3.3.2	Calibration.....	77
3.3.3.3	Vignetting characteristic.....	102
3.3.3.4	Camera viewpoints.....	104
3.3.4	Window and background luminance.....	105
3.3.5	Temperature and relative humidity.....	108
3.3.6	Occupancy.....	110
3.4	Procedure.....	111
3.4.1	Participant recruitment.....	111
3.4.2	Participant selection criteria.....	112
3.4.3	Participation.....	112
3.4.4	Preliminary building selection criteria.....	113
3.4.5	Window blind usage survey.....	113
3.4.6	Window blind usage field study.....	114
3.5	Data processing and analysis.....	116
3.5.1	Survey data analysis.....	116
3.5.2	Field study data analysis.....	116
3.5.2.1	Longitudinal data analysis.....	117
3.5.2.2	Typical GEE output.....	119
3.5.2.3	Variable entry and model selection.....	121

CHAPTER 4: RESULTS

4.1	Pilot study on window blind usage.....	105
4.2	Window blind usage survey.....	106
4.2.1	Descriptive information.....	106
4.2.2	Why do people control their window blinds?.....	108
4.2.2.1	Window blind closing reasons.....	108
4.2.2.2	Window blind opening reasons.....	111

4.2.3	How do people control their window blinds?.....	114
4.2.3.1	Window blind positions by closing and opening reasons.....	114
4.2.3.2	Window blind positions on sunny and cloudy days.....	116
4.2.3.3	Frequency of slat angle adjustment on a sunny day.....	117
4.2.3.4	Frequency of adjustment on sunny and cloudy days.....	118
4.2.3.5	Influences from other factors.....	119
4.2.4	Satisfaction with physical environments.....	121
4.2.5	Preference for the installation of an automated/intelligent window blind.....	123
4.2.6	Summary of results from the window blind usage survey.....	123
4.3	Window blind usage field study.....	126
4.3.1	Descriptive information.....	126
4.3.2	Correlation between subjective responses and physical data.....	129
4.3.2.1	Visual comfort.....	132
4.3.2.2	Thermal comfort.....	141
4.3.3	Logistic window blind control models.....	147
4.3.3.1	Dependent Variable: Window blind closing preferences.....	148
4.3.3.2	Variable selection.....	149
4.3.3.3	Descriptive information.....	151
4.3.3.4	Single variable models.....	152
4.3.3.5	Multivariate models.....	157
4.3.4	Summary of results from the window blind usage field study.....	165

CHAPTER 5: DISCUSSION

5.1	Examination of window blind control models.....	169
5.1.1	Window blind control model selection.....	169
5.1.1.1	Model selection criteria.....	170
5.1.1.2	Model selection findings.....	175
5.1.1.3	Selection of the best model.....	177
5.1.2	Interpretation of logistic regression coefficients.....	179
5.1.2.1	Odds.....	179
5.1.2.2	Probabilities.....	181
5.1.2.3	Threshold values.....	183
5.2	Comparison of model prediction with actual window blind occlusion data..	184
5.3	Comparison of average occlusion value between empirical models.....	188
5.4	Implementation in energy simulation programs.....	190
5.4.1	Overview of building energy simulation program.....	191
5.4.2	Modeling window blind usage in EnergyPlus.....	192
5.4.3	Existing window blind control models.....	195
5.4.4	Contribution to the energy simulation.....	196
5.5	Implementation of the control models as the basis for future automated window blind systems.....	197
5.6	Summary of derived window blind control models.....	199
5.7	Integration of physical and non-physical factors in the window blind control models.....	201

5.7.1	A conceptual decision-making model.....	202
5.7.2	Decision-making model based on the physical environmental criteria.....	204
5.7.3	Integration of physical and non-physical criteria.....	204
5.7.4	Influence of local comfort on global perception of comfort.....	207
5.8	Discussion on the assessment of visual comfort.....	208
5.8.1	Discomfort glare prediction from simple luminance-based variables.....	208
5.8.2	Multivariable models of discomfort glare prediction.....	209
5.8.3	Contextual influences.....	210

CHAPTER 6: CONCLUSIONS

6.1	Recommendations for future work.....	212
6.1.1	Longitudinal analysis method.....	212
6.1.2	Analysis of luminance characteristics.....	212
	6.1.2.1 Recommended locations for luminance measurements.....	212
	6.1.2.2 Second-generation digital luminance map program.....	214
6.1.3	Additional window blind usage studies are needed.....	215
6.1.4	Additional considerations for future automated blind systems.....	218
6.2	Conclusions.....	219

BIBLIOGRAPHY	222
---------------------------	-----

APPENDICES

APPENDIX A: APPROVAL LETTER FROM THE CPHS: EXEMPTED PROTOCOL.....	238
APPENDIX B: APPROVAL LETTER FROM THE CPHS: REVISED PROTOCOL.....	239
APPENDIX C: WINDOW BLIND USAGE SURVEY - GENERAL.....	240
APPENDIX D: WINDOW BLIND USAGE SURVEY - REPEATED SURVEY..	250
APPENDIX E: WINDOW BLIND USAGE SURVEY - REAL-TIME ASSESSMENT OF VISUAL AND THERMAL COMFORT.....	252
APPENDIX F: OPINIONS ON AN IDEAL AUTOMATED WINDOW BLIND SYSTEMS.....	256

LIST OF FIGURES

		Page
Figure 2.1	Model of environmental processes (from Olgyay, 1963).....	11
Figure 2.2	Flattening the temperature curve (from Olgyay, 1963).....	12
Figure 2.3	The semi-lattice relationship of environmental parameters of indoor comfort (from Elzeyadi, 2002).....	16
Figure 2.4	“Les Persiennes”, engraved by Louis Philip Debucourt (1820).....	17
Figure 2.5	Daylight transmission as a function of blind tilt angle for various solar incidence angle (from Athienitis & Tzempelikos, 2002).....	20
Figure 2.6	Direct-hemispherical transmittance vs. slat angle for normal incidence of double glazing unit with Venetian blinds (from Breitenbatch et al., 2001).....	21
Figure 2.7	Thermal performance of automated venetian blind system with a selective low-e glazing for the summer and winter (from Rheault & Bilgen, 1990).....	23
Figure 2.8	Block diagrams of recent window blind control models.....	42
Figure 3.1	Example of shielded and unshielded illuminance sensors used to calculate the DGI (from Aizlewood, 2001).....	51
Figure 3.2	Table of position index.....	53
Figure 3.3	Example of visual comfort variables from equidistant projection luminance maps.....	57
Figure 3.4	Maximum luminance ratios recommended for a VDT workstation (from IEANA, 2000).....	60
Figure 3.5	Loe’s 40° horizontal field of view (from Loe et al., 2000).....	61
Figure 3.6	Derived photometric values for the study of preferred luminous conditions, based on Loe’s 40° band (from Veitch & Newsham, 2000).....	61
Figure 3.7	Central and surrounding fields of view (from IESNA, 1951).....	62

Figure 3.8	The normal field of view of a pair of human eyes (from Stein & Reynolds, 2000).....	62
Figure 3.9	Example of luminance ratio variables from fisheye photographs.....	64
Figure 3.10	Categories of direction of VDT related to window.....	70
Figure 3.11	Categories of direct solar penetration.....	70
Figure 3.12	Installation of string potentiometer in workspace.....	71
Figure 3.13	Tilt sensors calibration apparatus.....	71
Figure 3.14	Actual installation of tilt sensor on venetian blind.....	72
Figure 3.15	Typical output from a string potentiometer.....	73
Figure 3.16	Typical output from a tilt sensor.....	73
Figure 3.17	Window blinds occlusion steps that were identified from time-lapse photography.....	74
Figure 3.18	Gray-scale squares used for the calibration of the Photolux system.	78
Figure 3.19	Comparison between captured and measured luminance values: Interior scene with electric light only.....	79
Figure 3.20	Comparison between captured and measured luminance values: Exterior scene with diffuse sky/no sunlight.....	80
Figure 3.21	Comparison between captured and measured luminance values: Exterior scene with direct sunlight.....	81
Figure 3.22	Scattered plot of measured and captured absolute luminance values: All data points.....	83
Figure 3.23	Scattered plot of measured and captured log luminance values: Excluding 95 and 100 target points.....	83
Figure 3.24	The vignetting characteristic of the fisheye lens FC-E9.....	85
Figure 3.25	Digital camera viewpoints.....	87
Figure 3.26	Shielded and unshielded illuminance sensors mounted on a free-standing pole.....	88

Figure 3.27	Example of a free-standing pole location in actual office.....	89
Figure 3.28	Dimension for the calculation of configuration factor (from IESNA,2000).....	90
Figure 3.29	Pictures of the instruments in the field.....	92
Figure 3.30	Graph of a typical voltage discharge of occupancy sensor capacitor.	93
Figure 3.31	Illustration of the population average (GEE) and the subject specific approach (random coefficient analysis) for linear and logistic regression (from Twisk, 2003).....	102
Figure 3.32	Example of a GEE analysis output.....	103
Figure 4.1	Plan view diagram of the workspace that was used in the window blind usage survey.....	106
Figure 4.2	Window blind closing reasons.....	108
Figure 4.3	Comparison between approximate times of closing window blind to control glare on VDT and to increase visual privacy.....	109
Figure 4.4	Window blind closing reasons by façade orientation.....	110
Figure 4.5	Window blind opening reasons.....	111
Figure 4.6	Approximated time of opening window blind to increase daylight in workspace.....	112
Figure 4.7	Window blind opening reasons by façade orientation.....	113
Figure 4.8	Window blind positions for each window blind closing reason.....	114
Figure 4.9	Window blind positions for each window blind opening reason.....	115
Figure 4.10	Window blind positions on sunny and cloudy days.....	116
Figure 4.11	Frequency of window blind slat adjustment.....	117
Figure 4.12	Comparison of window blind height adjustment frequency between sunny and cloudy days.....	119
Figure 4.13	Comparison of window blind position between naturally ventilated and air-conditioned offices.....	120

Figure 4.14	Distribution of satisfaction rating on overall window blind performance.....	121
Figure 4.15	Distribution of satisfaction rating of overall lighting.....	122
Figure 4.16	Distribution of satisfaction rating of overall temperature.....	122
Figure 4.18	Distribution of vertical solar radiation before a log-transformation.....	130
Figure 4.18	Distribution of vertical solar radiation after a log-transformation.....	130
Figure 4.19	Scatter plot of glare sensation as a function of maximum window luminance.....	134
Figure 4.20	Scatter plot of glare sensation as a function of average window luminance.....	134
Figure 4.21	Scatter plot of glare sensation as a function of transmitted vertical solar radiation at window.....	135
Figure 4.22	Scatter plot of glare sensation as a function of background luminance.....	135
Figure 4.23	Scatter plot of glare sensation a function of Daylight Glare Index (Hopkinson-Chauvel's formula).....	136
Figure 4.24	Scatter plot of glare sensation a function of Daylight Glare Index (Fisekis et al.'s formula).....	136
Figure 4.25	Multiple regression model of glare sensation as a function of background luminance and vertical solar radiation at window.....	140
Figure 4.26	Multiple regression model of glare sensation as a function of background luminance and maximum window luminance.....	104
Figure 4.27	Multiple regression model of glare sensation as a function of background luminance and average window luminance.....	140
Figure 4.28	Scatter plot of thermal sensation as a function of air temperature.....	143
Figure 4.29	Scatter plot of thermal sensation as a function of vertical solar radiation at window.....	143

Figure 4.30	Scatter plot of thermal sensation as a function of Mean Radiant Temperature.....	144
Figure 4.31	Multiple regression model of thermal sensation as a function of air temperature and vertical solar radiation at window.....	145
Figure 4.32	Multiple regression model of thermal sensation as a function of Mean Radiant Temperature and vertical solar radiation at window..	145
Figure 4.33	Regression model of thermal sensation as a function of air temperature by direct solar penetration condition.....	146
Figure 4.34	Regression model of thermal sensation as a function of Mean Radiant Temperature by direct solar penetration condition.....	146
Figure 4.35	Example of window blind occlusion value and occupancy profile on day five of the field study.....	148
Figure 4.36	Model L1, logistic model of window blind closing as a function of maximum window luminance.....	155
Figure 4.37	Model L2, logistic model of window blind closing as a function of vertical solar radiation at window.....	155
Figure 4.38	Model L3, logistic model of window blind closing as a function of background luminance.....	156
Figure 4.39	Model L4, logistic model of window blind closing as a function of average window luminance.....	156
Figure 4.40	Model M2, logistic model of window blind closing as a function of vertical solar radiation at window and brightness sensitivity.....	161
Figure 4.41	Model M3, logistic model of window blind closing as a function of vertical maximum window luminance and Mean Radiant Temperature.....	161
Figure 4.42	Model M4, logistic model of window blind closing as a function of maximum window luminance and brightness sensitivity.....	162
Figure 4.43	Model M5, logistic model of window blind closing as a function of background luminance and brightness sensitivity.....	162
Figure 4.44	Model M7, logistic model of window blind closing as a function of average window luminance and Mean Radiant Temperature.....	163

Figure 4.45	Model M8, logistic model of window blind closing as a function of average window luminance and brightness sensitivity.....	163
Figure 4.46	Model M9, logistic model of window blind closing as a function of average window luminance and direct solar penetration.....	164
Figure 5.1	Idealized ROC Curves with the corresponding value of area under each of the ROC curve.....	174
Figure 5.2	Logistic model of window blind closing as a function of vertical solar radiation at window.....	196
Figure 5.3	North, east and south façade of the building that was monitored during the pilot study.....	199
Figure 5.4	Categories used in identifying window blind positions.....	199
Figure 5.5	Average window blind occlusion value of three façade orientations	200
Figure 5.6	Ideal total transmitted vertical solar radiation for a building in Berkeley, CA on September 21 (equinox condition).....	200
Figure 5.7	Configuration of a typical operable window in the pilot study.....	202
Figure 5.8	Average window blind occlusion for different solar penetration depth for the occupied time when the solar radiation at window was above 50 W/m ²	203
Figure 5.9	Average window blind occlusion prediction from Model L2 for vertical solar radiation at window of 50 W/m ²	189
Figure 5.10	Simplified diagram of EnergyPlus program.....	194
Figure 5.11	Two-stage process of Signal Detection Theory.....	202
Figure 5.12	Deriving responses from signal and noise distributions.....	203
Figure 5.13	Two-stage window blind control model modified from the two-stage process model of Signal Detection Theory.....	205
Figure 5.14	Scatterplot of glare sensation as a function of modified Daylight Glare Index.....	211
Figure 6.1	Limited registration of luminance values in consequence of the luminance sensor position at the back of the room.....	213

LIST OF TABLES

		Page
Table 2.1	Example of optical and thermal properties of venetian blinds.....	23
Table 3.1	List of variables in the current study.....	47
Table 3.2	Comparison of different glare criteria.....	67
Table 3.3	ASHRAE seven-point scale of thermal sensation and McIntyre Thermal Preferences Scale.....	67
Table 3.4	Combinations of exposure time/aperture settings that were used to create luminance map.....	76
Table 3.5	Nikon Coolpix 5400 camera settings that were used to create luminance map.....	76
Table 3.6	Typical field study schedule.....	98
Table 4.1	Descriptive statistics of survey participants (n = 113).....	106
Table 4.2	Summary of field study participants' descriptive information.....	127
Table 4.3	Window blind position by façade orientation.....	128
Table 4.4	Summary of Chi-Square and Fisher's Exact Test for window blind position preferences.....	129
Table 4.5	Descriptive statistics for independent variables.....	130
Table 4.6	Intercorrelations (<i>r</i>) among visual comfort variables (n = 60).....	131
Table 4.7	Intercorrelations (<i>r</i>) among thermal comfort variables (n = 73).....	131
Table 4.8	Summary of regression analysis for variables predicting discomfort glare sensation.....	132
Table 4.9	Summary of longitudinal multiple regression analysis for predicting discomfort glare sensation.....	139
Table 4.10	Summary of regression analysis for variables predicting thermal comfort sensation.....	142

Table 4.11	Summary of longitudinal multiple regression analysis for variables predicting thermal comfort sensation.....	144
Table 4.12	Multicollinearity diagnostics for selected predictor and confounding Variables.....	150
Table 4.13	Descriptive statistics for selected independent variables by window blind closing preference.....	151
Table 4.14	Frequency of window blind closing preferences by direct sun penetration condition.....	151
Table 4.15	Frequency of window blind closing preferences by sky condition....	151
Table 4.16	Summary of logistic regression analysis for variables predicting window blind closing events.....	153
Table 4.17	Estimated threshold values (at $p = 0.5$) for various physical environmental predictors.....	157
Table 4.18	Summary of multiple logistic regression analysis predicting window blind closing events.....	160
Table 4.19	Estimated average window luminance threshold values (at $p = 0.5$) for different levels of confounding factors.....	165
Table 5.1	Classification table for Model L2.....	171
Table 5.2	Classification of model's accuracy rating based on the area under the ROC Curve (after Tape, 2005).....	175
Table 5.3	Summary of model selection criteria.....	176
Table 5.4	Comparison of input and output between existing and derived window blind models in DOE-2/EnergyPlus.....	199

ACKNOWLEDGEMENTS

I was able to complete this dissertation with encouragement, assistance, and support from many wonderful mentors, friends, colleagues, complete strangers, and family members.

First of all, I would like to thank Professor Lersom Stapidanonda, currently the Head of the Faculty of Architecture, Chulalongkorn University, Thailand, for accepting me as a junior lecturer in 1996 and granting me the opportunity to receive the Royal Thai Government Scholarship in 1997 to pursue the graduate study abroad. I am grateful to the University of California, Energy Institute (UCEI), the Illuminating Engineering Society of North America (IESNA), Golden Gate Section, the American Society of Heating, Refrigerating, and Air-Conditioning Engineers (ASHRAE), Golden Gate Chapter for providing financial support.

I am deeply indebted to all of my academic mentors for their intellectual guidance over the past eight years. I would like to express my gratitude to my academic advisors, Professor Charles Benton, Professor Edward Arens, Professor Stephen Palmer, and Professor Thomas Wickens, who helped structure my research and provided invaluable comments. I would like to express special thanks to Professor Marietta Millet and Professor Joel Loveland at the University of Washington who introduced me to the art and science of daylighting. In addition, Professor Peter Lyman was an enormous help to me in planning the ethnography of technology field study.

The work on visual comfort and luminance mapping technique could not be completed without help and support of my supervisor and colleagues at the Lawrence Berkeley National Laboratory (LBNL). I would like to thank Eleanor Lee, Robert Clear, and Steve Selkowitz at LBNL for guiding me toward the understanding of research in windows and daylighting. I feel privileged to have been a part of the Windows and Daylighting Group at LBNL for many wonderful years.

I also would like to thank the Pacific Energy Center for lending me the monitoring equipment used in this study. More importantly, I would like to thank all of my research participants for their time.

Over the years, many friends have helped me through thick and thin. I could not say thank you enough for hours of their moral and emotional support. I would like to thank Matthew Duckworth and Gerald Kelly for their endless hours of proofreading, Wanitchaya “June” Kittikraisak for being my personal statistician, Humberto Cavallin, Therese Pepper, Leah Zagreus and other wonderful staff members and students at the Building Science Group and College of Environmental Design for their help with the research.

And last but not least, there is nothing that can compare to the sacrifices by my father, Virasak Inkarojrit, my mother, Pissamai Inkarojrit, and my brother, Vorapinit Inkarojrit that have made me the person I am today. My deepest thanks goes to my entire Inkarojrit family for their endless love.

Berkeley, California, USA, June 19, 2005

CHAPTER 1

INTRODUCTION

1.1 Background

The fenestration system of a commercial building drives much of the building's energy consumption for heating, ventilating, air-conditioning (HVAC) and lighting. When exterior shading is inadequate, building occupants must rely on interior shading devices such as venetian blinds and shades for controlling the amount of light and heat that enters their offices. Even though such devices can make conditions more comfortable for building occupants, previous research has shown that venetian blinds are adjusted infrequently (Rubin, Collins, & Tibbott, 1978; Rea, 1984; IESNA, 2000), and that blinds and shades are usually set for worst-case conditions (IESNA, 1999; Bordass, Cohen, Standeven, & Leaman, 2001). When used correctly, shading devices can greatly reduce the amount of direct sunlight admitted into a space, substitute electric light with daylight, and thus reduce energy consumption. In order to harvest such energy-saving benefits from daylight, many fenestration systems with automated components integrated with daylight dimming systems have been developed.

While significant energy savings and peak demand reductions are possible through automatically controlled blinds (Lee, DiBartolomeo, & Selkowitz, 1998; Vartiainen, Peippo, & Lund, 1999; Athienitis & Tzempelikos, 2002; Roche, 2002), many buildings that have automated shading systems are reported to experience serious technical and operational problems (Mahone, 1989; Bordass, Bromley, & Leaman, 1993; Jain, 1998; Bordass et al., 2001; Stevens, 2001; Benton, 2003). Many of the problems

appear to come from misjudgments at the design stage of how building occupants interact with the shading systems. Occupants often dislike the systems and find ways to override, circumvent, and disable them. If designers better understood what occupants require or desire from the fenestration systems in their offices, then it would be possible to design better control strategies for automated systems.

This research project examines building occupants' behavior when controlling window blinds and derives predictive control models by observing how occupants interact with a manual system over which they have varying degrees of personal control. The venetian blind was chosen instead of other types of interior shading system because it is the most common type of interior shading system in contemporary office buildings.

1.2 Problem Statement

Research on automated fenestration systems has traditionally been focused on improving physical performance, with two goals. The primary goal has been to reduce total building energy consumption and the secondary goal has been to continuously satisfy occupants' comfort and satisfaction.

While results from previous studies suggest that the energy performance of office buildings with integrated automated window blinds and lighting control is superior to those with static glazing systems (Lee & Selkowitz, 1997; Lee et al., 1998; Roche, 2002), anecdotal evidence has mounted concerning occupants' dissatisfaction with automated systems (Jain, 1998; Stevens, 2001; Benton, 2003). For example, Mahone (1989) reports that the automated blinds at the Pacific Bell Administrative Center in San Ramon, CA were lowered more often than necessary due to problems with the photo-sensors.

Automated blinds were finally decommissioned based on the occupants' complaints (Benton, 2003). At the San Francisco Public Library the malfunctioning of automated shades resulted in worse environmental quality than in spaces with manually controlled interior shades (Jain, 1998). Most recently, Stevens (2001) interviewed facility managers and occupants of eight buildings with automated blinds and reported that occupant satisfaction levels were lower in buildings with partial or full automated façade components than in buildings where there was full occupant control of the façade.

Most previous research has not examined the interaction between building occupant and window system, even though this interaction directly influences interior environmental conditions and the acceptance of automated blind systems. Without consideration of human requirements, preferences, and behaviors, it is not possible to realize the potential physical, environmental, and psychological benefits from automated fenestration systems.

1.3 Objectives

This study aims to review and extend present knowledge of manual control strategies of window blind systems in air-conditioned office buildings. The goal is to develop predictive manual control models for window blinds that can be used as a function in energy usage simulation programs, and to provide the basis for the development of future automated shading systems that respond to the users' satisfaction and preferences. The specific objectives of this study are to:

1. Explain building occupants' patterns of window blind usage with the emphasis on how and why window blinds are closed.

2. Determine whether variation in physical environmental conditions, such as level of visual and thermal comfort, influences the control behavior of window blinds.
3. Determine whether contextual variation, such as sky condition and seating orientation, influences the control behavior of window blinds.
4. Determine whether individual lighting and temperature preference influences the control behavior of window blinds.

1.4 Hypotheses

The main hypothesis is that the probability of window blind closing events is a function of physical environmental conditions that are related to the occupants' perception of indoor comfort. Based on the literature review, visual comfort and thermal comfort are described as the two major factors that influence the window blind control behavior. Therefore, this research examines the window blind closing events in relation to these two factors which are each influenced by contextual variations and individual lighting and temperature preferences.

While research in thermal comfort has been greatly advanced, research on visual comfort, especially discomfort glare from windows has received less attention. The existing Daylight Glare Index has been widely challenged on the issue of its validity and reliability (Boubekri & Boyer, 1991; Iwata et al., 1991; CIE, 1983; Inoue & Itoh, 1989; Iwata & Tokura, 1998; Aizlewood, 2001). In order to predict window blind usage based on the lighting environment, a prediction of discomfort glare sensation from luminous environment must be established. Therefore, a subsidiary hypothesis is that visual comfort sensation can be predicted as a function of lighting environmental conditions.

1.5 Scope and Limitations

As will be seen in the literature review, there are many factors that influence the control behavior of window blinds. These factors include:

1. Physical environmental factors such as the regulation of light, heat, and ventilation between interior and exterior environment.

2. Psychological factors such as the regulation of view and privacy, and the individual aesthetic preferences.

3. Physiological factors such as individual lighting and temperature preferences, individual ability to adapt to the changing physical environment, age, and gender.

4. Contextual factors such as seating orientation, façade orientation, types of task being performed, types of glazing, window blind, or shade.

5. Social factors such as group dynamics (in open plan vs. private offices), and personal space.

It is not possible to examine all factors at once. Therefore, this study focuses on the predictor variables that might be directly implemented in current building control systems and energy simulation programs. From the literature review, the most promising variables are mainly related to the visual and thermal environment. A few physiological and physical factors such as individual preferences and seating orientation were also examined. Other factors such as view, privacy, type of office were controlled or excluded.

Because random selection of buildings and participants is rarely possible in a quasi-experimental study (field study instead of laboratory study), participants were recruited from a limited subject pool.

Due to time, cost, and efficiency limitations, this study could only be conducted at buildings in one geographical location: Berkeley, California, USA. The study was completed during the vernal equinox to winter solstice period (September 2004 – February 2005) to amplify the effect of low angle sun and to minimize the effect of overheating. Since occupant behavior may vary between climatic conditions, the results of this study might be applied with caution to regions with different climates, or for the summer season.

1.6 Approach

A two-part study of window blind control behavior was conducted. The first part consisted of a survey on window blind usage, and the second part consisted of a field study on window blind usage. Several preliminary tasks were completed prior to the final survey and field study:

1. Developing window-blind monitoring methods for reliable measurement of blind positions and blind slat angles.
2. Determining the extent to which variation in indoor environmental conditions (as reflected in the level of visual and thermal comfort sensation) influences the operation of window blinds.
3. Validating the usability and reliability of research protocol and equipments.
4. Developing a portable field study instrument kit.
5. Acquiring approval from the Committee for the Protection of Human Subjects.

Once these tasks were completed, the recruitment process was initiated. Research participants were recruited from various institutions, private companies, and professional organizations to participate in the survey portion of the study. Those who participated in the survey were invited to participate in the field study.

With a limited number of participants, data were repeatedly collected over a period of time. An applied longitudinal data analysis technique (Generalized Estimating Equations and Random Coefficient Analysis), which takes into account within-subject covariates, was chosen as the main analysis technique.

The data were analyzed using several statistical analysis methods to derived logistic models that represent how window blinds were controlled, to investigate main effects and interaction effects of independent variables, and to investigate relationships between subjective responses and objective measurements. The results define various models that are suitable for use as a window blinds control function in energy simulation programs.

The model's prediction was compared with actual window blind occlusion data and results from previous window blind studies. Finally, various ways of implementing the predictive models in the energy simulation programs and future automated window blind systems are discussed.

1.7 Organization

This dissertation is divided into six chapters. The first chapter includes the problem statement, objectives, research questions, and hypotheses. It also includes the limitations and approach to achieving the objectives of the study. Chapter two reviews the literature on the functions of window and window blind usage. Chapter three outlines the methods and procedures used in the survey and field study. Data analysis techniques are also discussed in this chapter. Results of this research are presented in chapter four including responses from the window blind usage survey and the predictive models of how people control their window blinds. Chapter five discusses results with respect to model selection and model interpretation. The similarities and differences between derived and existing window blind control models are discussed in the context of implementation of the models in energy simulation programs and in future automated blind systems. Lastly, chapter six summarizes the study and recommends directions for future research.

CHAPTER 2

LITERATURE REVIEW

The control of a simple interior window shading system is a complex behavior that is influenced by physical, psychological, physiological, and social factors. The first part of this chapter provides an overview on the concept of comfort. The second part reviews the properties of Venetian blinds with an emphasis on the visual and thermal environment. The third part reviews previous studies on window blind control and existing window blind control algorithms. The chapter closes with a discussion of gaps in the literature.

2.1 Concept of comfort

Comfort and discomfort in an environment are major concerns for the occupants of buildings. The answer to the question “what is comfort?” is complex and varies widely when viewed from different disciplines. Simple or single-dimensional definitions of comfort are almost guaranteed to be inadequate in explaining the concept of comfort (Brager & De Dear, 2003). Using an onion with overlapping layers as a metaphor, the notion of comfort can be seen as evolving through time in which new meanings, shaped by culture, add additional layers to the previous ones (Rybczynski, 1986).

Historically, the notion of comfort referred to domestic attributes such as privacy, convenience, leisure, and ease (Brager & De Dear, 2003). Using early modern British and Anglo-American domestic environments as case studies, Crowley (2001) suggests that comfort was originally associated with spirituality and morality. For example, many

of the early and most influential innovations in the design of domestic artifacts such as chimneys, fireplaces, and glazed windows, were associated with the ascetic, non-parochial clergy, and gender privacy.

The eighteenth-century consumer revolution developed a culture of comfort that synthesized comfort's new physical meaning with a traditional one of moral support. During this time, comfort was recognized as culturally progressive rather than physically natural. Physical comfort had developed into a culture to be learned and demonstrated as a sign of social progress. By the nineteenth century, the idea of comfort included values, consumption patterns, and behaviors in which all people were believed to be entitled to the same physical comforts (Crowley, 2001). This is perhaps the first time that the term was used to refer to physical environmental comforts such as light, heat, and ventilation (Rybczynski, 1986).

2.1.1 Providing physical comfort: Environmental control systems

A principal purpose of environmental control systems is to provide conditions for human comfort. Prior to the development of new sources of power in the eighteenth and nineteenth centuries, interior environment was passively controlled in which all elements of a building were used to protect building occupants from the unpredictable climate without any aid from mechanical systems. The industrial age brought with it cheap energy and the development of electric lighting and mechanical ventilation. Heating/cooling devices freed architects from the constraints of climate and the restriction of passive methods (Baird, 2001).

In response to technological advancement of heating/cooling and lighting systems, a few models that link comfort and environmental control system were proposed. For example, using terminology of that period, Olgyay (1963) offered a model (see Figures 2.1) in which the relationship between “climatology” and “biology” is mediated by the combined processes of “architecture” and the new component “technology” (Hawkes, 1996). With his bioclimatic approach, Olgyay proposes that the most effective role for mechanical systems is in the final stage of fine-tuning the environmental capability of the building, not as the primary instrument of mediation (see Figure 2.2).

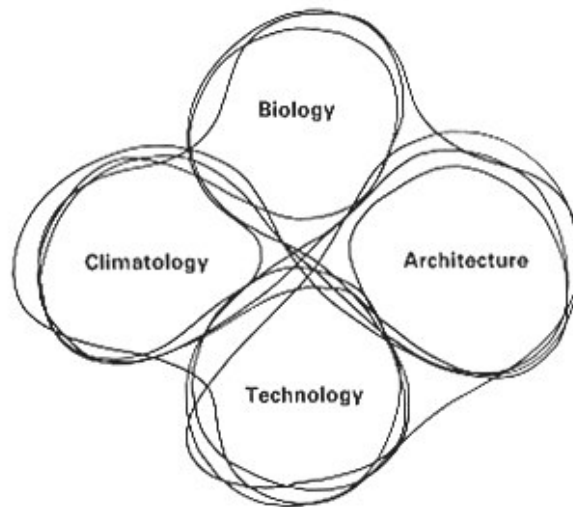

Figure 2.1 Model of environmental processes (from Olgyay, 1963).

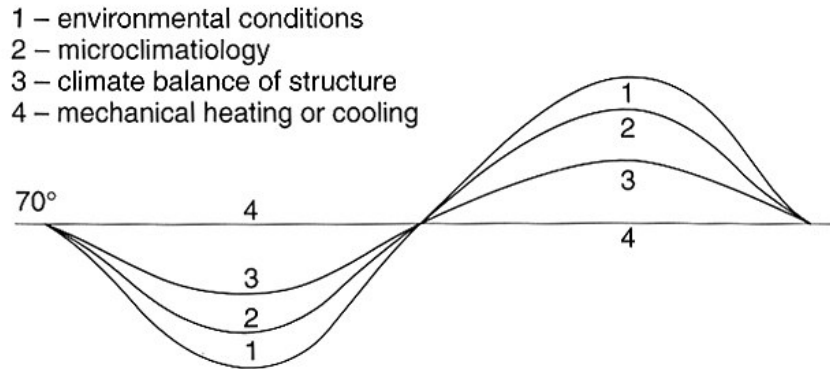

Figure 2.2 Flattening the temperature curve from (1) ambient environmental conditions, (2) by microclimatology, (3) climate balance of structure, and (4) mechanical heating or cooling (from Olgyay, 1963).

Similarly, Banham (1969) identified three modes of environmental management: conservative, selective, and regenerative. According to Banham, totally mechanical environments were “the fruit of a revolution in environmental management that is without precedent in the history of architecture, a revolution too recent to have been fully absorbed and understood as yet, and a revolution still turning up unexpected possibilities.”

Recently, Hawkes (1996) reworked Banham’s terminology to make clear differences between buildings that use ambient energy sources in creating natural environments (selective) and those that rely predominantly upon mechanical systems to create controlled artificial environments (exclusive).

The characteristics of selective mode buildings are: (1) the environment is controlled by a combination of automatic and manual means and is a variable mixture of natural and artificial, (2) shape is dispersed, seeking to maximize the use of ambient energy, (3) orientation is a crucial factor, (4) windows are large on southerly façades and restricted to the north; solar controls are required to avoid summer overheating, and (5)

energy is a combination of ambient and generated, and use is variable throughout the year with a peak in the winter and “free-running” in the summer.

The characteristics of exclusive mode buildings are: (1) the environment is automatically controlled and predominantly artificial, (2) shape is compact, seeking to minimize the interaction between inside and outside environments, (3) orientation is relatively unimportant, (4) windows are preferably but often not restricted in size, and (5) energy is primarily from generated sources and is used throughout the year in a relative constant quality.

The majority of commercial buildings in the United States use active environmental control systems in which building occupants heavily rely on electrical illumination and Heating, Ventilating and Air-Conditioning (HVAC) systems to maintain comfort. Nevertheless, “selective characteristics” are integrated allowing building occupants to fine-tune their immediate environment. Manually-controlled window blinds is one of many selective characteristics that can be found in most, if not all, “exclusive mode” commercial buildings.

2.1.2 Beyond physical comfort: Adaptive comfort model

Most people usually consider indoor comfort to be related to physical environment (e.g., light, heat, acoustics, air quality, furniture layout, etc.). The physical environmental properties, however, are not the only factors that influence the perception of comfort. Using thermal comfort as an example, the American Society of Heating, Refrigerating, and Air-Conditioning Engineers (ASHRAE) defines comfort as the condition of mind that expresses satisfaction with the thermal environment (ASHRAE,

1992). This definition of comfort, however, does not convey the complexity of comfort and all of its contextual and cultural influences (Brager & De Dear, 2003).

Over the past few decades, the Adaptive Principle (Humphreys & Nicol, 1998) has gained more popularity among building science researchers, especially in the field of thermal comfort, as the model that help explaining the complexity of comfort. The Adaptive Principle suggests that comfort, sensation, and preferences are influenced not only by climate but also culture and expectation. According to this principle, the definition of indoor comfort is extended beyond physical environmental conditions.

Based on data from numerous thermal comfort field studies (rather than controlled laboratory studies), proponents of adaptive thermal comfort argue that building occupants' thermal sensations and preferences are significantly and predictably influenced by culture, climate, and thermal expectation and adaptation. Recently, the adaptive model of thermal comfort has been integrated into the ASHRAE Standard 55-2004, complementing the traditional heat balance thermal comfort model (Fanger, 1970; Gagge, Fobelets, & Berglund, 1986). A detailed review of adaptation is beyond the scope of this dissertation. An extensive literature review on this issue, however, can be found in Brager and De Dear (1998) as well as Humphreys and Nicol (1998).

Looking beyond static models of comfort, where building occupants are viewed as passive recipients of discomfort, the adaptive model consider a range of responses (behavioral, physiological, psychological adjustments) which building occupants undertake to maintain their 'state' of comfort. Brager and De Dear (1998) summarize these three categories of adaptation as:

1. Behavioral adaptation: This refers to behavioral adjustments, including all modifications a person might consciously or unconsciously make, in modifying heat and mass fluxes that govern the body's thermal balance. These adjustments can be at a personal level (changing clothes, activity, posture, etc.), technological level (opening/closing windows, blinds, or shades, turning on/off fans or lights, etc.), or cultural level (rescheduling activities, adapting dress codes, etc.).

2. Physiological adaptation: The human body can acclimate to short-term or long-term exposure to discomfort. Short-term adaptation includes shivering, sweating, dilation of pupils, etc. Long-term adaptation refers to a genetic adaptation, which later becomes part of the genetic heritage of an individual or group of people.

3. Psychological adaptation: This type of adaptation includes the effects of cognitive and cultural variables. It is believed that the perception of comfort is attenuated by one's past experiences and expectations.

2.1.3 Restoring comfort: Window blind control as adaptive behavior

Review of comfort literature above suggests that the control of window blind is one of the adaptive behaviors that building occupants act upon a change that produce discomfort. Therefore, the hypothesis in this study states that window blind control behavior can be predicted as a function of physical environmental conditions that produce discomfort sensation. Thus far, no study exists that explain the relationship between the perception of comfort/discomfort and window blind control behaviors.

Review of literature shows that comfort is a complex perception which reflects the interaction between objective stimuli and cognitive/emotional processes in which the

general perception of comfort is a result of the overall comfort appraisal through human's senses (Elzeyadi, 2002; see Figure 2.3). These senses act as the sub-systems of indoor comfort.

Unfortunately, previous comfort studies usually focused on one sub-system (e.g. visual comfort or thermal comfort). There are only a few studies (Fanger et al., 1977; Rohles et al., 1981; Laurentin et al, 2000) that cross-analyzed data from more than one sub-system of indoor comfort at one time. Because the functions of window blinds relate to many sub-systems of comfort, therefore, it is necessary understand how the sub-systems of indoor comfort influence the general perception of comfort and the window blind control behaviors.

A detail review of factors that could potentially influence the perception of comfort and the control of window blinds is given in section 2.3.

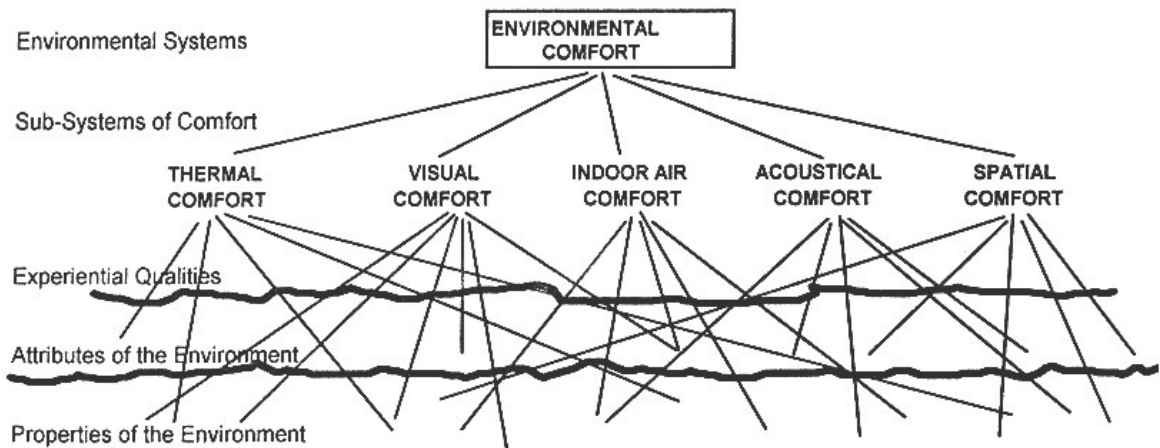

Figure 2.3 The semi-lattice relationship of environmental parameters of indoor comfort (from Elzeyadi, 2002)

2.2 Venetian blinds

Most windows in commercial buildings have some type of internal shading to give varying degrees of sun control and to provide privacy and aesthetic effects (Ozisk & Schutrum, 1960; ASHRAE, 1997; Littlefair, 1999). Due to its low cost compared to other types of interior shading devices, manually controlled Venetian blinds are perhaps the most common type of interior shading devices in contemporary office buildings. Fully opened Venetian blinds can be somewhat less effective for reflecting solar heat than fabric roller blinds since the reflectance of the slats in aggregate is less than that of the individual slats. When fully closed, window blinds are often better than translucent fabric shades in dealing with glare because they can give complete shielding against direct sun, reflect more ambient light inside in the direction of the ceiling, and provide a view out.



Figure 2.4 “Les Persiennes”, engraved by Louis Philip Debu-court (1820)

2.2.1 Brief history of Venetian blinds

The idea of the Venetian blind is as old as sunlight filtering through the leaves of palm trees in the tropic oases, in which glare can be controlled while hindering cooling air (Jones, 1941). In its original form of curtain reeds, Persian slaves would pour water frequently upon the curtain reeds. This resulted in evaporation by the hot winds and served as a cooling medium for the living chamber. The idea of a blind was then transferred from Persia to Venice and later to France and the rest of Europe.

The use of Venetian blinds has been recorded in England and the United States as far back as the late eighteenth century (Manning, 1965). For example, Venetian blinds were illustrated in the painting by J.L. Gerome Ferris, “The visit of Paul Jones to the Constitutional Convention, 1787”. The R.C.A. building in the Rockefeller Center is the first modern building in the United States of the skyscraper type to have installed Venetian blinds as standard equipment (Jones, 1941).

Modern Venetian blinds were originally made of thin wooden slats (or lamellae) suspended on fabric webbing in such a way that the slats could be tilted through a wide angle or raised to the top of the window out of the aperture (Baker & Steemers, 2002). Nowadays, modern materials such as aluminum or plastic are used more often as slats while the angular control and raising/lowering can be achieved either manually or automatically via motorized control.

2.2.2 Physical properties of Venetian blinds

In order to evaluate building energy performance, estimate peak electrical load, and ensure occupant comfort, the determination of optical and thermal properties of

fenestration systems is required. Below is the summary of optical and thermal properties of Venetian blinds.

2.2.2.1 Optical properties

Papamichael and Beltran (1993) developed a method for determining the optical properties of window systems with Venetian blinds for evaluating integrated envelope and lighting systems. It combines experimental measurements in scale models and mathematical routines to produce a daylight factor for window systems with different blind slat angles. These factors are used in the DOE-2 building energy simulation program to determine workplane illuminance on an hourly basis (Lee & Selkowitz, 1995).

While the prediction of workplane illuminance has proven to be useful, lighting researchers are becoming more interested in predicting discomfort glare sensation from vertical luminance and illuminance (Osterhaus, 1998; Aries, 2003). Because Venetian blinds are an optically complex system, the development of mathematical routines for the prediction of optical properties is still under way. So far, lighting researchers have developed two types of methods for predicting surface transmission of a window with Venetian blinds: simple and complex. These methods have been derived from comprehensive scaled model studies, digital imaging studies, or ray-tracing simulation.

For the simple lighting/energy simulation method, one may consider using the transmission values for a fixed Venetian blind position independent of sky condition (Stephenson, 1964; Littlefair, 1999; see Table 2.1).

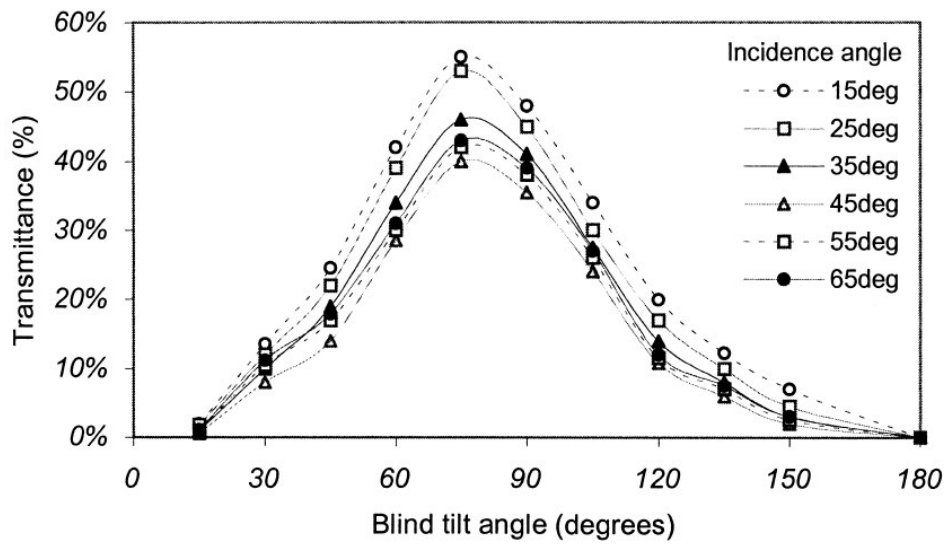

(a)

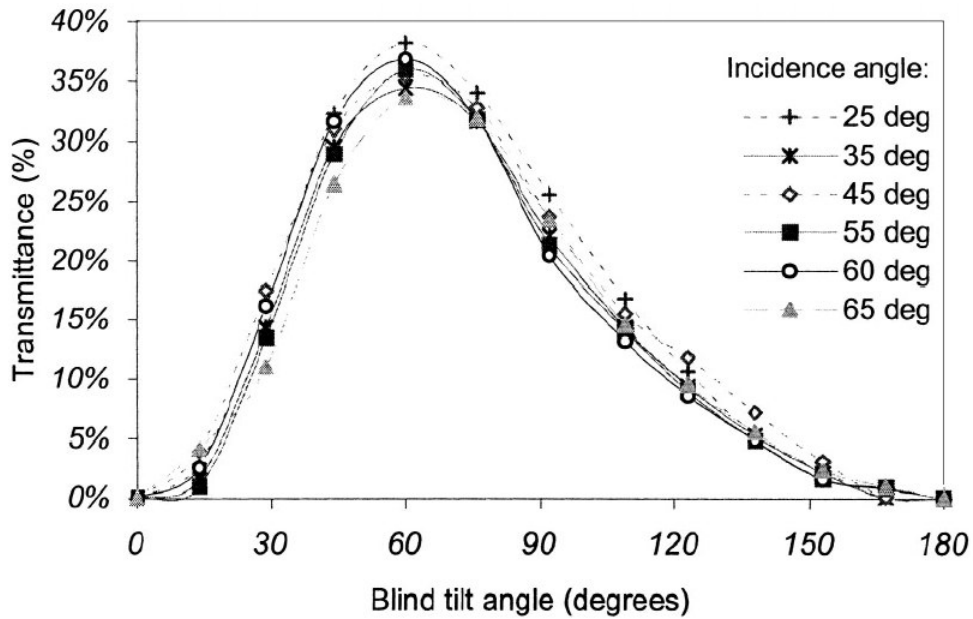

(b)

Figure 2.5 Daylight transmission as a function of blind tilt angle for various solar incidence angles; clear day (a) overcast day (b) (from Athienitis & Tzempelikos, 2002).

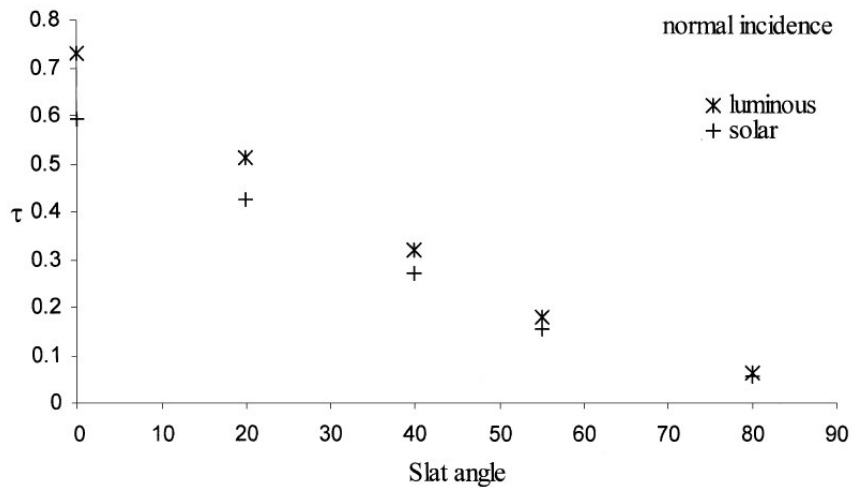

Figure 2.6 Direct-hemispherical transmittance vs. slat angle for normal incidence of double glazing unit with Venetian blinds (from Breitenbach, Lart, Langle, & Rosenfeld, 2001).

For the complex calculation method, one may calculate window blind transmission values based on blind tilt angle, angle of solar incidence, and sky condition. For example, Athienitis and Tzempelikos (2002) determined transmittance equations for a window system that has Venetian blinds placed between two panes of glass as a function of sky conditions, blind tilt angle and angle of incidence. They found that for overcast days, the tilt angle had a strong effect on daylight transmittance. For clear sky conditions, the solar incidence angle has a significant effect on transmittance (see Figure 2.5a and 2.5b).

For an even more complex daylighting simulation, one may consider using the Bi-directional Transmission Distribution Function (BTDF; Andersen et al., 2001; Andersen et al., 2005; Andersen, 2002; Breitenbach et al, 2001; see Figures 2.6). A detailed review of BTDF is beyond the scope of this dissertation. More information can be found in the literature listed above.

2.2.2.2 Thermal properties

For a simple calculation of building energy performance, architects, engineers and designers use tables within the ASHRAE Handbook of Fundamentals (ASHRAE, 1997) for determining the Solar Heat Gain Coefficients (SHGC) of various fenestration system products (Ullah & Lefebvre, 2000). The Solar Heat Gain Coefficient (SHGC) is a number that describe how well a product blocks heat caused by sunlight. The SHGC is expressed as a number between 0 and 1 which represents the fraction of incident solar radiation admitted through a window then subsequently released inward. The lower a window's SHGC, the less solar heat it transmits. It should be noted that the SHGC for window systems with Venetian blinds as listed in the ASHRAE tables, were limited to only one blind type and a few blind slat angles (see Table 2.1).

For a more complex building energy performance calculation, previous research (Lee & Selkowitz, 1995) used the thermal performance derived from a mathematical model created for a between-pane louver system with diffused blind surface reflectance (Rheault & Bilgen, 1990; see Figure 2.7). Alternatively, one may consider using the interpolation of blind properties based on small sets of characteristic SHGCs that was proposed by Klems and Warner (1997).

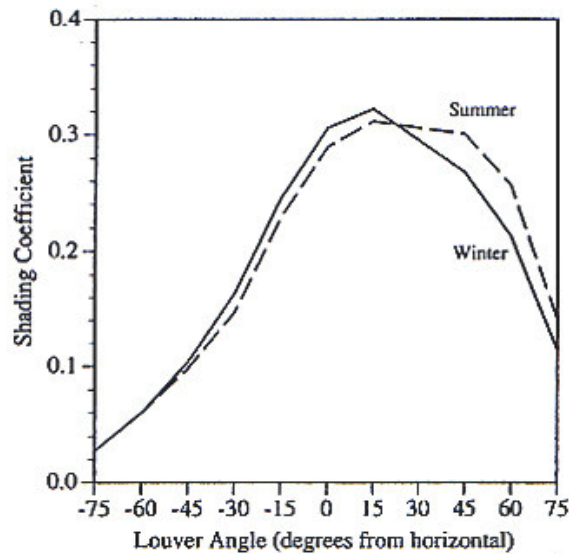

Figure 2.7 Thermal performance of automated Venetian blind system with selective low-E glazing for the summer and winter. The Shading Coefficient (SC) is shown as a function of the Venetian blind tilt angle. The thermal performance was mathematically derived for a between-pane system with gray-diffuse louver surfaces (after Rheault & Bilgen, 1990).

Table 2.1 Examples of Optical and Thermal Properties of Venetian Blinds

	Blind Position/ Color	Solar Reflect	Solar Absorp.	Solar Trans.		Optical Trans.	
				Summer (Default)	Winter	Diffuse (Cloudy)	Sunny
Stephenson (1964)†	0	-	-	-	-	0.3	-
	22.5	-	-	-	-	0.14	-
	45	-	-	-	-	0.08	-
ASHRAE (1997)‡	light	0.55	0.40	(0.05)	-	-	-
	medium	0.35	0.60	(0.05)	-	-	-
Littlefair (1999)*	Shut	-	-	0.57	0.58	0.03	-
	Open	-	-	-	-	0.32	-
Athienitis (2002)**	-60	-	-	-	-	(0.14)	0.1
	-30	-	-	-	-	(0.38)	0.35
	-15	-	-	-	-	(0.33)	0.48
	0	-	-	-	-	(0.25)	0.42
	30	-	-	-	-	(0.11)	0.15
	60	-	-	-	-	(0.03)	0.03

† A typical lighted-color Venetian blind

‡ Ratio of slat width to slat spacing 1.2, slat angle 45, normal incidence

* Venetian blind type not available

** 35 mm wide mid-pane highly reflective Venetian blind between double-glazed low-E coating

2.3 Previous studies on the control of window blinds

Although limited in observation and identification methods, early researchers were able to distinguish blind usage patterns between façade orientations and sky conditions. Recently, window blind movements and physical environmental conditions were monitored simultaneously. From these data, researchers have been able to derive window blind control rules based on simple predictors. Below is a summary of the previous studies on human control of window blinds.

2.3.1 Monitoring of window blind usage

Rubins, Collins, and Tibbott (1978) studied manual blind control patterns in private offices with northern or southern façade orientations. The objectives of the study were to examine blind manipulation patterns, to examine various external variables in relation to blind usage, and to determine the energy saving potential of manually manipulated Venetian blinds. The results showed that building occupants consciously set their blinds in certain positions, and that blind occlusion is higher in southern than in northern offices because people tend to use their blinds to block direct sunlight. Significantly, they found that blinds were operated more than once a one day in only 50 out of 700 windows observed in the experiment. Finally, the authors suggested that each window occupant arrives at a preferred window blind position as a result of individual weighing of the positive (e.g. light in, view out) and negative effects (e.g. glare, privacy) of windows. This hypothesis, however, was not tested during that time.

Rea (1984) analyzed occupant-controlled blind positions on three façade orientations in a 16-story office building in Ottawa, Canada as a function of façade orientation, time of day, weather conditions, and the interactions between these variables. Similar to Rubin et al. (1978), Rea used the photographic analysis method to document window blind positions of each building façade orientation. The photographs were taken at three times of day (9:30, 12:00, 14:30), and on one cloudy and one clear day in April and May, 1982, respectively. A total of 3,330 windows were examined for their blind position. The proportion of the window opening covered by blinds was taken as an occlusion value with a range from 0-10. Blind slat angles were not considered in the calculation of this occlusion value.

The results showed that the sky condition (cloudy or clear) and building façade orientation (north, south, east, or west) and their interaction were statistically significant. The occlusion value was much higher on the clear day than on the cloudy day for the east façade, while there were small but consistent differences in occlusion on the south and west façades. Rea concluded that occupant preference for window blind position is based on long-term perceptions of solar radiation. Changes within a day are essentially ignored and occupants use window blinds to prevent penetration of direct sunlight, thermal radiation, or both in the room.

Inoue, Kawase, Ibamoto, Takakusa, and Matsuo (1988) took photographs of four buildings in Tokyo, Japan. Along with the photographs, direct and diffuse solar radiation values were collected. Inoue et al. reported that the change in the rate of blind operation varied greatly with the orientation of the buildings, weather conditions, and that pattern of window blind control emerged particular to the individual building investigated.

Window blinds on the east façade were closed by occupants on their entry into the rooms but gradually opened upward in the afternoon when the sun was not shining through the windows. Blinds on the west façade were opened as the building occupants arrived and closed in the afternoon as solar radiation increased. Blinds were not operated during overcast weather, when solar radiation values were low.

The major conclusion from Inoue et al. (1988) study was that once direct solar radiation striking a façade exceeded about 12-58 W/m² (10-50 kcal/m²h), blind occlusion was proportional to the depth of sunlight penetration into a room. Thus, Inoue et al. were the first to establish a correlation between the occlusion value and the amount of solar radiation incident on a façade.

Lindsay and Littlefair (1992) investigated Venetian blind usage at five different office buildings in England, using time-lapse photography as the primary monitoring method. In the buildings monitored, the blind change rate ranged from never (0%) to daily (100%) with an average of 40%. Blinds were operated in response to the amount of sunshine present and the position of the sun with respect to façade orientation. Occupants lowered their blinds during the day as direct sunlight penetrated their façade and retracted them at the end of the working day or early in the morning. Based on their blind usage data, Lindsay and Littlefair hypothesized that the general motivation for people to use blinds is to avoid glare rather than to prevent overheating.

Pigg, Eilers, and Reed (1996) studied the behavioral aspects of lighting and occupancy sensors in private offices, and measured blind management through random walk-through inspections. They found that 36% of the 63 private offices they monitored never adjusted their blinds between February and May, 1995. Data from this study

support the results from Rea's (1984) study showing that façade orientations influence the control of window blinds. Pigg et al. reported that offices on the south facade of the building were most likely to be shut and least likely to be completely open. Offices on the north façade were the least likely to have the blinds closed. Offices that faced east and west were immediately between these extremes.

As part of her dissertation, Bülow-Hübe (2001) investigated the function, operation, and effect of daylight on external Venetian blinds and awnings. She asked 50 participants to adjust the shading device to create a pleasant daylight situation (without the aid of electric light) and then to adjust the electric lighting to create a pleasant environment. Bülow-Hübe recorded the position and blind slat angle of the blinds. She reported that most participants did not pull the Venetian blinds down fully.

Approximately 50% of the participants pulled them down half-way with an average occlusion of 66%. Seventy-five percent of the participants chose a slat angle of 30° or larger (from horizontal level). Less than 10% of the participants chose a negative (sky view) slat angle. Further, Bülow-Hübe reported that there was no relationship between interior illuminance levels or sky luminance and the coverage of the shading devices.

However, a relationship was found between coverage and the existence of sunlight patches in the field of view. Bülow-Hübe concludes that either glare or luminance contrast in the field of view are probably responsible for the control of shading devices, but there seems to be a large individual spread as to how much glare people tolerate.

Since the variance among people is large, more participants and weather situations should be included in future studies.

Foster and Oreszczyn (2001) videotaped blind movement in three offices in London, England. In this study, the average sunshine index and the average occlusion index were plotted for regression analysis. Blind slat angle was included in the occlusion index. The value of blind positions ranged from 0 to 5 (0=fully open, 5= fully closed) while the value for slat angle ranged from 1 to 3 (1=horizontal, 2=between horizontal and vertical, 3=vertical). Both values were divided by their maximum value to obtain the proportion of occlusion. The occlusion index was calculated by multiplying blind position and blind slat angle values. The sunshine index was calculated by multiplying the weather code (1=overcast, 2=slightly cloudy, 3=sunny) by time code (1=early morning or late afternoon, 2=mid afternoon, 3=midday).

Foster and Oreszczyn (2001) found that occupants' use of blinds was not affected by solar availability and that there was only a weak relationship between the degree of sunshine and the occlusion index. However, they found that the orientation of the façade did have some influence on the average level of occlusion. Blinds on the south façade had the highest occlusion value, and the occlusion value for the west façade was lower than the occlusion value for the north façade. The authors speculate that the building on which the north façade was observed was closer to the opposite building and that the blinds may have been drawn for privacy purposes.

One function of blinds is to intercept the direct solar radiation entering the building in warm or hot weather. Raja, Nicol, McCartney, and Humphreys (2001) found that blind usage increased with an increase in indoor temperature, outdoor air temperature, and thermal comfort sensation vote. The rate of change, however, was

small. Raja et al. speculated that the reason for using blinds is to avoid glare rather than to reduce heat.

Nicol (2001) analyzed the data from field studies that were conducted in Sweden, UK, France, Portugal, and Greece, and suggested that control of window blinds is influenced by physical conditions, but that it tends to be governed by a stochastic rather than a precise relationship. That is, the likelihood of an event happening increases as the “intensity” of the stimulus (in this case temperature) increases. Similar to Raja et al.’s (2001) finding, Nicol reported that the blinds were primarily used by building occupants to control glare rather than to control indoor temperature. While there was some evidence that occupants were more likely to use blinds in hotter weather, the effect was small and barely statistically significant. Ultimately, Nicol suggested that solar intensity would be a better predictor than outdoor temperature for explaining blind usage.

Reinhart (2001) investigated blind usage at an office building near Stuttgart, Germany. The author monitored ten sets of blinds in south-facing offices. In these buildings, electrical lighting and external Venetian blinds were connected to the building control system. Blind slats could be adjusted independently above and below a 2 meter height and was supported by an external lightshelf. Blinds were operated manually and automatically. Under an automated control system, blinds were fully lowered/retracted if the illuminance onto the SSW façade exceeded/fell below 28,000 lux. This automated blind control algorithm was chosen to avoid overheating. Manual control of blinds was possible at all times, and any manual blind manipulation disabled the automated blind control for two hours.

The status of blinds, vertical illuminance on façade, external temperature, and global/diffuse irradiance were recorded at 5-minute intervals, while the workplace occupancy, work plane illuminance, and indoor air temperature were recorded at 15 minute intervals. A total of 6,393 blind changes were recorded during 174 weekdays from late March to early December, 2000. This high blind movement rate was caused by the semi-automated blind control system in which 3,012 blind manipulations were carried out by the control systems, followed by 1413 user corrections which occurred within 15 minutes after an automated blind readjustment. A total of 1,973 blind adjustments were controlled manually. Reinhart's (2001) data supports findings from previous studies showing that people consciously set blind positions (Rubin, 1978), and that people dislike their blinds being closed unless direct solar radiation is above 50 W/m^2 (Inoue et al., 1988).

In summary, most of the aforementioned studies on blind usage indicate that blinds are consciously used in offices to block direct sunlight. Glare protection seems to be the main factor that influences window blind control behavior, followed by the avoidance of excessive solar heat gain. Accordingly, orientation of the façade influences blind control behavior. Blind occlusion values are generally higher in an office with a southern façade orientation rather than with a northern façade orientation.

2.3.2 Subjective responses to window blinds

Occupants' subjective responses to window blinds are an essential component in understanding why building occupants control their window blinds. Subjective responses are usually gathered through the use of an interview or questionnaire. Thus far, only a few studies measuring occupants' subjective responses have been carried out.

As part of their automated blind study, Inoue et al. (1988) reported the results from 336 questionnaires in which they asked "how do you control your nearest blind?" They found that 60-70% of the sample kept the blinds open as long as possible. Only 20-30% answered that they operate the blinds to meet outside changes. Furthermore, the percentage of answers stating that blinds greatly affect the visual environment reached as high as 90%, and the effect on the thermal environment accounts for 50-80%. The majority of the occupants stated that they preferred the space near the windows because it affords brightness (80%), view (70-80%), and extensive visual range (50-60%). Inoue et al. concluded that the reasons why blinds are operated can be inferred from the negative factors in the evaluation of seats near windows. The predominant negative factors found in this study are heat and glare generated by direct solar radiation.

Pigg et al. (1996) reported that 43% of building occupants adjusted their blinds to reduce the direct light coming into the room, while 37% said that they do so to reduce the glare on their computer screen.

Vine et al. (1998) compared satisfaction levels of 14 participants who experienced three hours in a full-scale test office under three different modes of an integrated Venetian blind and lighting system. They found that most participants preferred a higher workplane illuminance than the default range from 700 -1500 lux. Vine et al. concluded

that integrated Venetian blind and lighting systems exhibit high user acceptance, but that larger samples and longer measurement periods would be necessary to fully test this conclusion.

The few studies that have investigated automated blind operations show that only 50-60% of the building occupants were satisfied with the automated systems (Inoue et al., 1988, Jain, 1998). Only 57% of the sample felt that the overall lighting was comfortable, compared to manual override mode and manual blind control (78% and 85% respectively). These results demonstrate a need to investigate subjective responses to automated blind control systems and/or develop automated blind control algorithms that are based on user needs and preferences.

2.3.3 Other potential factors

There are many other physical, physiological, psychological, and social factors that influence window blind control behavior. Below are a few examples.

2.3.3.1 Visual privacy and visual exposure

Heerwagen (1990) suggests that a successful window design must provide a balance between visual access and visual exposure that is appropriate for the context and for the personal preferences of occupants. In the case of office buildings, it may be implied that the ideal fenestration systems should allow occupants to “see without being seen.”

2.3.3.2 View and access to environmental information

One function of window is the addition of a dynamic, active quality to an interior environment (Collins, 1975). Although almost any view is acceptable, some evidence suggests that views with high information content are preferable. Manning (1965) reported that nearly 90 percent of the participants in his study considered it important to be able to see out of their offices. Markus (1967) investigated the view function of windows and suggested that the satisfaction derived from a window view is probably related to the total visual field which it occupies, comprising the immediate foreground, middle distance, and sky.

Because most studies of glare from large source have been conducted in controlled laboratory settings, the hypothesis that view influences discomfort glare rating has not been confirmed. However, anecdotal evidence suggested that the appraisal of glare from actual windows, unlike glare from artificial lighting, may be affected by factors such as quality, in addition to the size and appearance, of the window. For example, Boubekri and Boyer (1992) conducted an experiment where subjective responses of discomfort glare sensation from 20 participants were compared with calculated glare using the Cornell glare formula (Hopkinson, 1972; Chauvel et al., 1982). Results from this experiment showed that glare was more tolerable than the daylight glare index predicts. It is concluded that this hypothesis remains to be tested.

2.3.3.3 Daylight, sunlight, satisfaction, and productivity

Growing evidence shows that there is an association between perceived productivity and factors such as comfort, health, and satisfaction of staff in office organizations (Leaman & Bordass, 1999). The presence of a window and daylight certainly has an effect on these factors. The argument is that over the life-cycle of a building, aggregate energy costs are very modest when compared to aggregate wages paid to employees. Despite long energy payback periods, if daylight can improve employee productivity, these productivity gains can offset the costs of almost any daylighting system.

The association between daylight and productivity has recently been the topic of investigation in retail and school settings (Heschong, 2002; Heschong, Wright, & Okura, 2002a, 2002b). Although the correlational analysis conducted in these studies cannot prove that daylighting causes increased sales in retail environments nor improved student performance in school environments, Heschong et al. (2002b) suggests that there is indeed an important daylighting effect associated with performance and productivity with increased window or skylight areas in buildings. These researchers have suggested three potential pathways for a daylight mechanism that improves human performance: increased visibility, enhanced mood, and improved health. Accounting for the benefits of daylight, it is hypothesized that building occupants who prefer to have access to daylight may leave their window blind open more than those that have no preference. This hypothesis, however, will not be tested in the current study.

2.3.3.4 Effect of long-term exposure

Discomfort from glare appears to have a cumulative effect. The longer building occupants are exposed to a glare source, the more sensitive to glare they become.

Poulton (1991) suggests that discomfort from glare is more troublesome at the end of the day or late in the week. This effect may occur even with very low luminance glare sources.

2.3.3.5 Age and gender

It is well established that visual performance decreases with age. The effect of age on discomfort from glare is undoubtedly an area that needs investigation. Results from previous studies suggest that an age effect exists. For example, Fisher and Christie (1965) found a significant positive correlation between age and the coefficient K in the formula for veiling luminance in disability from glare. This means that a given lighting condition would produce greater disability for older persons. Bennett (1977) reported that older people were more sensitive to discomfort from overly bright lighting systems than young people. The average population is more sensitive in direct proportion to their age from early 20s to their 70s. It is reasonable to expect that as various aspects of the visual system deteriorate with age, a greater sensitivity to discomfort from glare might result.

Although metabolism decreases slightly with age, previous studies (Nevins, Rohles, Springer, & Geyerherm, 1966; Fanger, 1982; Fanger & Langkilde, 1979) found that thermal environments preferred by older people do not differ from those preferred by younger people. However, since elderly people have lower activity than younger people,

the ambient temperature level in the homes of older people is found to be higher than the temperature level in the homes of younger people (ASHRAE, 1997).

Previously cited experiments by Fanger (1982), Fanger and Langkilde (1975), and Nevins et al. (1966) also compared thermal environment preferences between male and female participants. They concluded that gender was not found to have an effect on thermal environment preferences.

2.3.3.6 Contextual influences

Bennett (1977) conducted an experiment with 140 participants to investigate the relationship between glare and indoor-outdoor occupation. Results indicated that indoor workers were more sensitive to discomfort from glare than outdoor workers. This was most likely the result of psychological adaptation in which outdoor workers expected higher illuminance, therefore, they were more tolerant of glare compared to indoor workers. Based on the results of this experiment, it could be argued, then, that there are differences in glare tolerance among office workers due to past experience and expectations.

For thermal comfort, ASHRAE (1997) similarly suggested that people who are used to working and living in warm climates could more easily accept and maintain higher work performance in hot environments than people from cold climates. While adaptation has minimal influence on the preferred ambient temperature, in uncomfortable warm or cold environments there will often be an influence of adaptation on performance.

2.3.3.7 Effect of task viewing position on glare

While much attention has been given to evaluating discomfort glare from windows, very little work has evaluated how glare from windows is affected by the discomfort from bright areas surrounding the task site. Discomfort from glare has been assessed in previous studies by viewing and rating the glare source directly in conditions that simulate a worker looking up from a work task.

To be sure that research results are relevant to today's workforce and their environment, it is important to investigate situations in which the glare source occupies a substantial part of the visual field while subjects actually perform work tasks (Osterhaus & Bailey, 1992). Most modern office workers spend a lot of time at computer workstations. These include the Cathode Ray Tube (CRT) type monitor with a highly reflective surface and Liquid Crystal Display (LCD) type monitor with a matte finish. The location of Video Display Terminal (VDT) tasks in relation to windows should be taken into account in research examining discomfort from glare.

2.3.3.8 Interaction effects

The comfort or discomfort of an office occupant is predominantly determined by four main environmental factors: air quality, thermal comfort, acoustical ambience, and visual comfort. The interaction effects of these variables on comfort are not well-established and are usually based on only a few anecdotal reports. For instance, the effect of noise on visual fatigue has been demonstrated, and the influence of visual information on auditory sensation has been reported recently (Laurentin, Berrutto, & Fontoynt, 2000). However, their interaction and collective effect has not been studied.

Yamazaki, Nomoto, Yokota, and Murai (1998) investigated the effect of air temperature, light, and sound on perceived work environment. One of the major results obtained from the experiment was that when illuminance was low, the sensitivity to temperature was low, and with increasing illuminance, the sensitivity to temperature increased.

Laurentin et al. (2000) conducted an experiment specifically to test the hypothesis that thermal conditions have an effect on visual comfort. Twenty subjects reported visual and thermal comfort levels at two temperature conditions (20.5 and 27 °C), and under three light source types (daylight, electric light, and combined lighting) at a constant 300 lux illuminance. A significant effect of thermal conditions on lighting environment sensation was found under electric light only. The hypothesis that thermal conditions influence visual comfort appraisal was not supported. It was concluded that the effect of thermal discomfort on visual discomfort may not be significant because the maximum temperature in Laurentin's study was only 3°C above the (thermal) comfort zone,

The examples show that an interaction between thermal and visual comfort is plausible. A future predictive model of visual discomfort from daylight may integrate the effect of thermal discomfort as one of the confounding variables.

A list of the above-mentioned factors suggests that window blind control behavior is shaped by a complex range and balance of various physical, physiological, psychological, and social factors. The main and interaction effects of these factors on the window blind control behavior, however, are not fully understood. For example, it is hypothesized that in some situations such as ground level rooms, the desire for privacy

may overcome the desire for view and the desire for natural light (Collins, 1975). Nevertheless, it is not possible to examine all factors at once. Therefore, this study focuses on factors that can be directly implemented in current building control systems and energy simulation programs. The explanation of the chosen variables, which are mainly related to the visual and thermal environment, can be found in Chapter 3.

2.3.4 Existing window blind control algorithms

Currently, the development of blind control algorithms for automated and manually controlled blinds is still at a preliminary stage. For automated blinds, early control algorithms were “time controlled” for orientation and season or were based on a single solar radiation threshold value. For example, blinds were automatically adjusted based on the amount of direct solar radiation that reaches the occupants of the room (Inoue et al., 1988; Leslie, Raghaven, Howlett, & Eaton, 2005). Newsham’s (1994) blind operation model was based on the thermal comfort model assumption that, if sunlight with intensity greater than 233 W/m^2 fell on the occupants, the blinds would be closed. The value of 233 W/m^2 was chosen to reflect the 20% PPD thermal comfort criterion of the ISO Standard 7730 (1984). At the Helicon building in the UK, the blinds are lowered to the horizontal position when solar radiation incident on the façade reaches a threshold of 150 W/m^2 (CIBSE, 1996). Lastly, Oscar Faber Associates (as cited in Foster & Oreszczyn, 2001) chose the solar radiation threshold value of 300 W/m^2 to represent the threshold that occupants would start to use the window blinds.

Recent automatic blind control algorithms are closed-loop algorithms that integrate more environmental variables into the algorithm, such as workplane illuminance and sun angle. The major improvement is that the systems include manual override capability and possible optimization between visual and thermal comfort conditions (Guillemin & Morel, 2001). For example, the goal for the control algorithm of the automated Venetian blinds at the Oakland Federal Building's test-bed facility was to keep the interior workplane illuminance within the range of designed illuminance, approximately between 540 to 700 lux (Vine et al., 1998). The commercially available MechoShade's AAA SolarTrac™ adjusts shades in accordance with the solar angle and BTU load (MechoShade, 2001). Most recently, adaptive-fuzzy control, in which the position of window blinds are determined based on the optimization of multivariable predictors (solar radiation, visual comfort, thermal comfort) have been developed and simulated with a test façade model (Assimakopoulous, Tsangrassoulis, Guarracino, & Santamouris, 2004; Park, Augenbroe, Sadegh, Thitisawat, & Messadi, 2004).

For blinds that are manually controlled, there are only a few manual window blind control models that have been published in journal articles. For example, Reinhart's (2001) manual blind operation algorithm incorporates time of the day, space occupancy, and solar radiation as the major factors in blind opening or closing functions. However, Reinhart stated that the factor of time in his model is an over-simplification of reality and lacks supporting data. Furthermore, the model also ignores any thermally-driven mechanisms, which might further encourage the closing of blinds to avoid overheating during the summer or opening of blinds for increasing personal warmth during winter.

In summary, several blind control algorithms have been developed and implemented in buildings since the 1980s. Existing models reflect the function of windows in providing “physical” comfort with less consideration on the interaction between physical, physiological, psychological, and social dimensions. Even though recent algorithms include many variables, they are theoretically derived rather than derived from actual practice, and therefore their capacity to reflect building occupants’ preferences when implemented in actual buildings can be challenged. Only the models from Inoue et al. (1988) and Reinhart (2001) were derived from actual observations. Clearly, more field investigation is needed in order to understand the manual operation of window blinds.

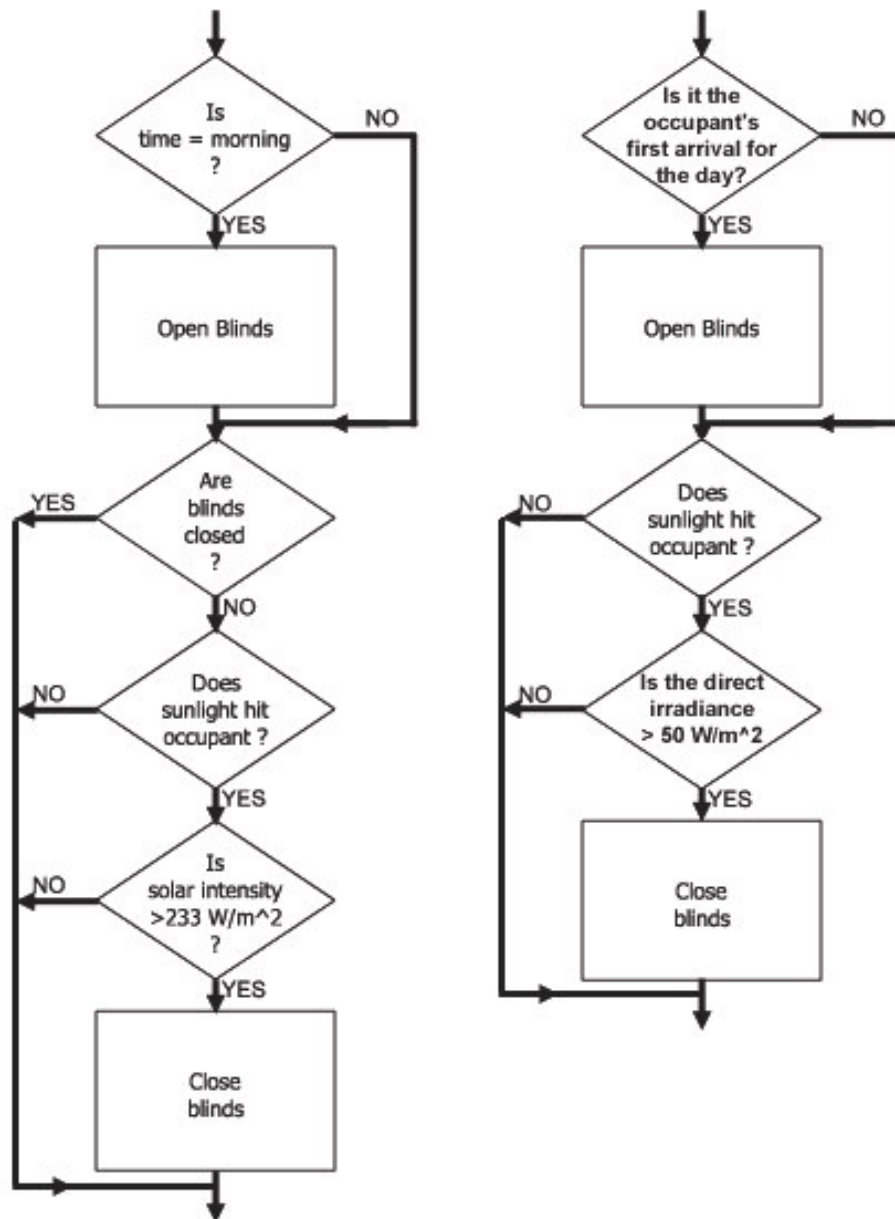

Figure 2.8 Block diagrams of recent window blind control models. Left: Newsham (1994) block diagram for manual blind control based on 20% PPD Thermal comfort criterion of ISO 7730 (1984). Right: Reinhart (2001) blind control model, which is a modification of Newsham's model. This model is based on the assumption that building occupants control their window blinds for visual comfort (low direct solar irradiance triggers blind closing actions).

2.4 Gaps in the literature

This literature review has identified several gaps in the literature on window blind control:

1. Previous research suggests that physical factors, such as visual and thermal comfort, are the major factors that influence the control of window blinds (Rubin et al., 1978; Rea, 1984; Lindsay & Littlefair, 1992; Newsham, 1994; Reinhart, 2001). In addition to the physical factors, the review of literature shows that physiological, psychological and social factors can influence the general perception of comfort as well. The main and interaction effects of these factors on the window blind control behavior, however, are not fully understood. Therefore, a combination of quantitative measurements and subjective surveys are needed in order to understand the effects of these factors on window blind control behavior and comfort appraisal.

2. Visual and thermal comfort factors (which have been cited in previous studies as the primary factors in blind control behavior) have not been investigated thoroughly. This might be the result of the current underdeveloped state of prediction methods for discomfort from glare from daylight.

3. Previous studies of window blind control were not conclusive; not all major façade orientations were monitored in a single study. In addition, the impact of room occupancy and seating position on window blind usage patterns has not been investigated in any study.

4. Measures of window blind occlusion have largely excluded window blind slat angles. Different window blind slat angles can drastically increase or decrease workplane illuminance for workspace near the window opening (Christoffersen, 1995).

In previous studies, window blind slat angles were ignored or identified as either open or closed. Blind slat angle should be investigated as a component of window blind occlusion indices.

5. In previous studies, researchers used cameras or camcorders to monitor the status of window blinds. The window blind positions were visually examined. While the position can be easily seen, there is potential error in recording it. Furthermore, the angles of the blind slats are usually ignored because of the different relative camera angles on different floors of tall buildings (Rea, 1984). There is a need for a more reliable method for measuring the window blind position and blind slat angle.

6. The existing window blind control models are oversimplified. The blind control models are constructed with an all-or-none absolute threshold rule. Window blind control should be expressed in terms of probability of blind movement in correlation with visual or thermal factors.

7. Only two window blind control models were derived from actual field studies. While theoretically constructed models optimize many variables, they may have limited applicability to real-life settings.

CHAPTER 3

METHOD

3.1 Introduction

Traditionally, environmental control system studies focus on only one domain of the physical environment: the lighting domain or the thermal domain. In addition, the evaluation of a system's technical performance is often based on data from the physical environment, and the integration of subjective responses is less common. The literature review establishes that window blind control behaviors are influenced by many factors, including physical and physiological, psychological and social variables. This study of Venetian blind control behavior focuses on the interaction between two environmental domains that are directly regulated by window blinds, the lighting and thermal environments. A variety of methods were used to collect and analyze the physical environmental and subjective data. Prior to the main experiment, pilot survey and study of window blind usage were conducted to validate research methods, test a few preliminary hypotheses, and gather preliminary information regarding frequency of blind change and occlusion value between façade orientations. The pilot study data were later used to inform the design of the main experiment. In addition, the data were used to validate the accuracy of the derived window blind control models.

This chapter describes the methods used to conduct the investigation, beginning with the study variables and instruments. The second section describes the research procedure and participant selection procedure. Lastly, the data analysis techniques are explained.

3.2 Study variables

Table 3.1 provides a list of all of the variables measured in this study. The dependent variables are related to window blind movements, especially, window blind closing event (yes = 1, no = 0). For independent variables, only those variables that met the following criteria are selected for inclusion in the study:

- 1) The variable is part of an equation used to calculate visual or thermal comfort.
- 2) The variable provides a measure of the physiological/psychological variability of an individual participant.
- 3) The variable is cited in previous window blind research.

In this study, independent variables are categorized into two types, treatment (stimulus) and confounding factors. Treatment variables are directly related to the stimulus that cause discomfort sensation. Confounding factors, on the contrary, are related to both the dependent and independent variables and may confound the association but they may or may not imply the causation. In this study, the confounding variables are considered grouping variable of sort.

A few secondary factors were included in the survey portion of the study, but were not taken into consideration in the field study portion due to a limited number of research participants. Examples of these variables include satisfaction with view, need for privacy, age, and gender.

Table 3.1 List of Variables in the Current Study

Type of variables	Items
Dependent variables	<ol style="list-style-type: none"> 1. Window blind closing event (yes = 1, no = 0) 2. Window blind occlusion value[†] 3. Frequency of window blind adjustment[†]
Independent variables	<ol style="list-style-type: none"> 1. Visual Comfort <ol style="list-style-type: none"> 1.1 Average window luminance* 1.2 Background luminance* 1.3 Daylight Glare Indices* 1.4 Maximum window luminance* 2. Luminance ratios between VDT task and <ol style="list-style-type: none"> 2.1 Adjacent surface (60° visual cone)* 2.2 Surrounding surface (120° visual cone)* 3. Thermal comfort <ol style="list-style-type: none"> 3.1 Air temperature* 3.2 Mean Radiant Temperature (MRT)* 3.3 Relative Humidity* 3.4 Predicted Mean Vote (PMV) 3.5 Predicted Percent Dissatisfied (PPD) 4. Subjective responses <ol style="list-style-type: none"> 4.1 Glare Sensation Vote (GSV)* 4.2 Brightness preference** 4.3 ASHRAE Thermal sensation vote* 4.4 Thermal preference** 4.5 Self-reported sensitivity to brightness** 4.6 Self-reported sensitivity to temperature** 5. Workplane illuminance* 6. Vertical solar radiation at window* 7. Additional confounding factors** <ol style="list-style-type: none"> 7.1 Direct solar penetration 7.2 Direction of VDT screen 7.3 Façade orientation[†] 7.4 Sky condition[†] 7.5 Age[†] 7.6 Gender[†]

* Treatment variables

** Confounding factors

[†] Variables included only in the survey portion of the study

3.2.1 Window blind movement

The main dependent variables in this study were related to window blind movement. They were measured in three ways: whether window blind states were open or closed (0 = closed, 1 = open), window blind occlusion level (a continuous value ranging from fully closed = 0 to fully open = 100), and an ordinal value representing frequency of window blind adjustment on a typical day (less than once per day, once per day, and more than once per day).

3.2.2 Visual comfort

Glare is defined by the Commission Internationale de l'Eclairage (CIE) as “the condition of vision in which there is discomfort or a reduction in the ability to see details or objects, or both, due to an unsuitable distribution or range of luminance or to extreme contrasts in space or time” (CIE, 1983). There are two separate forms of glare: discomfort glare, which causes discomfort without necessarily impairing vision of objects, and disability glare, which impairs vision without necessarily causing discomfort.

Although both forms of glare can occur simultaneously, they are quite different phenomena. Disability glare depends mainly on the quantity of light falling on the eye and is largely independent of luminance of the source. When light of relatively high luminance is seen against a low luminance background, it reduces the ability of the observer to see by reducing the contrast in the retinal image. Loss of vision can occur because contrast sensitivity decreases when glare is present. In buildings, direct sunlight in the field of view can cause disability glare.

Discomfort glare, on the other hand, depends on the source luminance.

Discomfort glare occurs when the presence of a light source that is of higher intensity than that to which the eye is currently adapted leads to unpleasant sensations that range from a mild annoyance to pain. Discomfort glare does not necessarily reduce visibility. In addition, discomfort glare can build up considerably in interior spaces where building occupants are exposed to high luminance sources for a long period of time.

Because glare is a subjective phenomenon; the primary method of investigation usually involves the subjective judgment of observers. In this method, observers rank glare sources of different luminance levels according to the discomfort sensation they perceive. Glare index equations are derived from these experiments, which produce guidelines and recommendations for lighting installations.

There are many predictive models of visual discomfort. These predictive models include the American Visual Comfort Probability (IESNA, 2000), the British Glare Index (Hopkinson & Bradley, 1960; Hopkinson, 1949, 1963; Hopkinson & Collins, 1963), the Luminance Limit (Bodmann, 1967), the CIE Glare Index (CIE, 1983; Navvab & Altland, 1997), and the Unified Glare Rating (Einhorn, 1969, 1979, 1998; CIE, 1995). These models all share similar predictive equations which include luminance of the source (L_s), adaptation (or background) luminance (L_b), position of the source relative to the line of sight (p), and apparent size of the glare source (ω) (Boyce, 2003). All of these models can be expressed using the same general form:

$$G = \frac{L_s^a \cdot \omega^b}{L_b^c \cdot p^d} \quad (3.1)$$

Equation 3.1 suggests that the discomfort glare sensation increases with the luminance of the source and the solid angle subtended by the source, and decreases with increasing background luminance and deviation of the glare source from the line of sight.

Most of the glare models, however, cannot be used to predict discomfort glare from daylight. One of the assumptions of these models is that the size of a glare source is less than 0.01 steradian. The Daylight Glare Index (DGI; Hopkinson, 1963; Chauvel et al., 1982) is the only model that has been widely accepted in predicting discomfort glare from large sources such as windows.

Based on the Hopkinson Daylight Glare Index (1963), Chauvel et al. (1982) reviewed studies of glare from large artificial light sources, and investigated glare from daylight seen through real windows. The authors then modified the formula by giving a new definition to source luminance and adding the average luminance of the window as a new parameter. The new Chauvel et al. (1982) formula is given below:

$$DGI = 10 \log 0.478 \sum_{i=1}^n \frac{L_s^{1.6} \cdot \Omega^{0.8}}{L_b + (0.07 \cdot \omega_s^{0.5} \cdot L_s)} \quad (3.2)$$

where

- L_s Average luminance of each glare source in the field of view (cd/m^2)
- L_b Average luminance of the background
- ω Solid angle of the source seen from the point of observation (sr)
- Ω Solid angle subtended by the source, modified for the effect of the position of the observer in relation to the source (sr)
- n Number of glare sources in the field of view

To assist in determining L_s and L_b in actual built environment, Aizlewood (2001) proposed a protocol for continuous measurement of shielded and unshielded vertical illuminance from which L_s and L_b can be derived. This relieves the need for making a series of spot luminance measurements. An example of vertical sensors is shown in Figure 3.1.

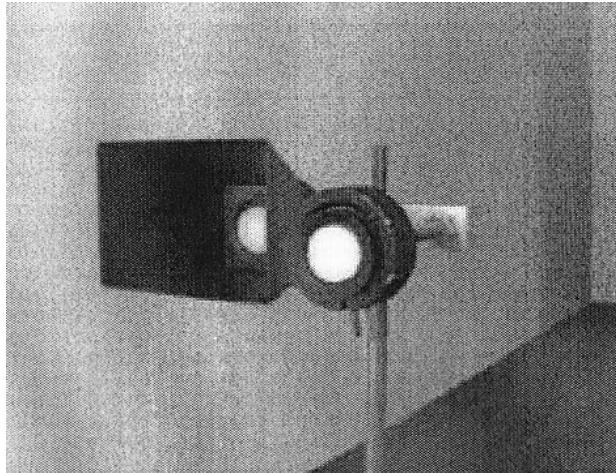

Figure 3.1 Example of shielded and unshielded illuminance sensors used to calculate the DGI (from Aizlewood, 2001).

The glare source is determined from:

$$L_s = \frac{E_s}{\pi \cdot \phi} \quad (3.3)$$

where

E_s Average vertical illuminance from shielded illuminance sensor (lux)

ϕ Configuration factor of source in respect to the measurement point

The background luminance L_b is given by:

$$L_b = \frac{E_s - E_{um}}{\pi \cdot (1 - \phi)} \quad (3.4)$$

where

E_{um} Average vertical illuminance from unshielded illuminance sensor (lux)

The solid angle subtended by the glare source (window) to the point of observation can be calculated using the following equation:

$$\omega = \frac{A \cdot \cos \theta \cdot \cos \phi}{d^2} \quad (3.5)$$

where

A Window (source) area

d Distance from the viewpoint to the center of the source

θ The angle between the normal to the source and the direction of the source from the observer in the vertical plane

ϕ The angle between the normal to the source and the direction of the source from the observer in the horizontal plane

Finally, the solid angle subtended by the source, modified for the position of the light source with respect to the position index (see Figure 3.2), can be calculated using the following equation:

$$\Omega = P_i \cdot \omega \quad (3.6)$$

where

P_i Position index

TABLE 12.7
POSITION FACTOR p (FOR USE WITH FIGURE 12.7)

		Horizontal angle ($\phi = \tan^{-1} L/R$)																		Vertical angle ($\theta = \tan^{-1} V/R$)	
		0°	6°	11°	17°	22°	27°	31°	35°	39°	42°	45°	50°	54°	58°	61°	63°	68°	72°		
Vertical displacement (V/R)	1.9	—	—	—	—	—	—	—	—	0.02	0.02	0.02	0.02	0.02	0.02	0.02	0.02	0.02	0.02	62°	
	1.8	—	—	—	—	0.02	0.02	0.02	0.02	0.02	0.02	0.02	0.02	0.02	0.02	0.02	0.02	0.02	0.02	61°	
	1.6	0.03	0.03	0.03	0.03	0.03	0.03	0.03	0.03	0.03	0.03	0.03	0.03	0.03	0.03	0.03	0.03	0.03	0.03	58°	
	1.4	0.04	0.04	0.04	0.04	0.04	0.04	0.04	0.04	0.04	0.04	0.04	0.04	0.04	0.04	0.04	0.04	0.04	0.03	54°	
	1.2	0.05	0.05	0.06	0.06	0.06	0.06	0.06	0.06	0.06	0.06	0.06	0.05	0.05	0.05	0.05	0.04	0.04	0.04	50°	
	1.0	0.08	0.09	0.09	0.10	0.10	0.10	0.10	0.09	0.09	0.09	0.08	0.08	0.07	0.06	0.06	0.06	0.05	0.05	45°	
	0.9	0.11	0.11	0.12	0.13	0.13	0.12	0.12	0.12	0.12	0.11	0.10	0.09	0.08	0.07	0.07	0.06	0.06	0.05	42°	
	0.8	0.14	0.15	0.16	0.16	0.16	0.16	0.15	0.15	0.14	0.13	0.12	0.11	0.09	0.08	0.08	0.07	0.06	0.06	39°	
	0.7	0.19	0.20	0.22	0.21	0.21	0.21	0.20	0.18	0.17	0.16	0.14	0.12	0.11	0.10	0.09	0.08	0.07	0.07	35°	
	0.6	0.25	0.27	0.30	0.29	0.28	0.26	0.24	0.22	0.21	0.19	0.18	0.15	0.13	0.11	0.10	0.10	0.09	0.08	31°	
	0.5	0.35	0.37	0.39	0.38	0.36	0.34	0.31	0.28	0.25	0.23	0.21	0.18	0.15	0.14	0.12	0.11	0.10	0.09	27°	
	0.4	0.48	0.53	0.53	0.51	0.49	0.44	0.39	0.35	0.31	0.28	0.25	0.21	0.18	0.16	0.14	0.13	0.11	0.10	22°	
	0.3	0.67	0.73	0.73	0.69	0.64	0.57	0.49	0.44	0.38	0.34	0.31	0.25	0.21	0.19	0.16	0.15	0.13	0.12	17°	
	0.2	0.95	1.02	0.98	0.88	0.80	0.72	0.63	0.57	0.49	0.42	0.37	0.30	0.25	0.22	0.19	0.17	0.15	0.14	11°	
	0.1	1.30	1.36	1.24	1.12	1.01	0.88	0.79	0.68	0.62	0.53	0.46	0.37	0.31	0.26	0.23	0.20	0.17	0.16	6°	
	0	1.87	1.73	1.56	1.36	1.20	1.06	0.93	0.80	0.72	0.64	0.57	0.46	0.38	0.33	0.28	0.25	0.20	0.19	0°	
			0	0.1	0.2	0.3	0.4	0.5	0.6	0.7	0.8	0.9	1.0	1.2	1.4	1.6	1.8	2.0	2.5	3.0	
			Lateral displacement (L/R)																		

V = vertical distance from horizontal line of vision
L = lateral distance from horizontal line of vision
R = horizontal distance from eye of observer

Figure 3.2 Table of position index (from Hopkinson et al., 1966, p.323)

While DGI has been accepted as the standard for predicting glare from large sources for many years, several anecdotal studies have challenged the reliability and validity of DGI. For example, subjective assessment of discomfort glare under real sky conditions has been found to be less than that predicted from DGI in two studies (Boubekri & Boyer, 1991; Iwata et al., 1991). Boubekri and Boyer suggested that view pleasantness may have influenced the assessment.

Because DGI was based on an experiment with uniform light sources (Hopkinson, 1972), Waters et al. (1995) showed that a non-uniform glare source caused more glare than a uniform source when positioned perpendicular to the line of sight.

Inoue and Itoh (1989) suggested that when the glare source size approached 2π steradians, background luminance was highly influenced by the source. Therefore, the calculated DGI should be independent of background luminance.

In calculating glare from large sources, different subdivisions of a large glare source resulted in different glare index values. That is, the glare index value increased as the number of source subdivisions increased (CIE, 1983; Iwata & Tokura, 1998; Inkarojrit et al., 2005).

Finally, Aizlewood (2001) suggested that the DGI is a daylight glare index, not a sunlight glare index. If direct sunlight fell on the measuring apparatus, the formula became unreliable.

Many researchers have proposed alternative methods to predict discomfort glare sensations. For example, vertical illuminance (or simple brightness) may be used to predict discomfort glare (Osterhaus & Bailey, 1991; Osterhaus, 1998; Loe et al., 2000; Aries, 2003; Cuttle, 2003). Using an apparatus similar to Aizlewood's (2001) measure, Nazzal (2001) conducted an experiment using shielded and unshielded illuminance sensors to calculate DGI. With the hypothesis that sky luminance has a significant influence on discomfort glare, Nazzal (2001) replaced the L_s (nominator in the Chauvel's formula) with $L_{exterior}$, the average vertical unshielded illuminance from the surrounding environment (at the window). Nazzal (2001) reported that the new DGI_N method provided reasonable (more stable) results. The DGI_N formula is given as:

$$DGI_N = 10 \log 0.478 \sum_{i=1}^n \frac{L_{exterior}^{1.6} \cdot \Omega^{0.8}}{L_b + (0.07 \cdot \omega_s^{0.5} \cdot L_s)} \quad (3.7)$$

Fisekis et al. (2003) explored the effect of the adaptation function by evaluating DGI according to different interpretations of the background luminance. Realizing that for a large glare source the shielded and unshielded vertical illuminance sensors tend to become equal ($E_{un} = E_s$), Fisekis et al. (2003) hypothesized that DGI can be overestimated.

Therefore, another representation of the background luminance (adaptation luminance) has been used to avoid this limitation:

$$L_a = \frac{E_{un}}{\pi} \quad (3.8)$$

By correlating subjective responses with measured illuminance data, Fisekis et al. (2003) showed that DGI- L_b performed well for the criteria falling within the discomfort zone (DGI>24) and overestimated the predictions within the comfort zone. DGI- L_a also performed better as a predictor at lower glare source levels, and underestimated predictions at higher glare source levels. Fisekis et al. concluded that as the source luminance rises, a saturation process takes place and the influence of the average luminance in the adaptation function has a declining effect which can be accommodated into the formula by raising L_a to an exponent of less than one. The final DGI_{mod} equation takes the form of:

$$DGI_N = 10 \log 0.478 \sum_{i=1}^n \frac{L_s^{1.6} \cdot \Omega^{0.8}}{L_b^{0.85} + (0.07 \cdot \omega_s^{0.5} \cdot L_s)} \quad (3.9)$$

In summary, while the methods for predicting discomfort glare from daylight have not yet been resolved, the Daylight Glare Indices remains the most widely used indicator for daylighting applications despite its accepted limitations and will be use in this study.

This research monitors several components of the basic glare formula (see Figure 3.3):

L_{win} Average luminance of the window (cd/m^2)

L_{glol} Background luminance defines as the average luminance of the interior room surfaces (including window) and calculated as luminance averaged over the hemisphere of view (cd/m^2)

L_{mxwin} Maximum luminance of the window (cd/m^2).

Two variations of DGI were calculated from the window luminance and the background luminance, and were compared with subjective responses from participants. These DGIs were:

DGI_h Daylight Glare Index: Hopkinson – Chauvel’s formula (Equation 3.2)

DGI_f Modified Daylight Glare Index (Fisekis et al., 2003; Equation 3.9)

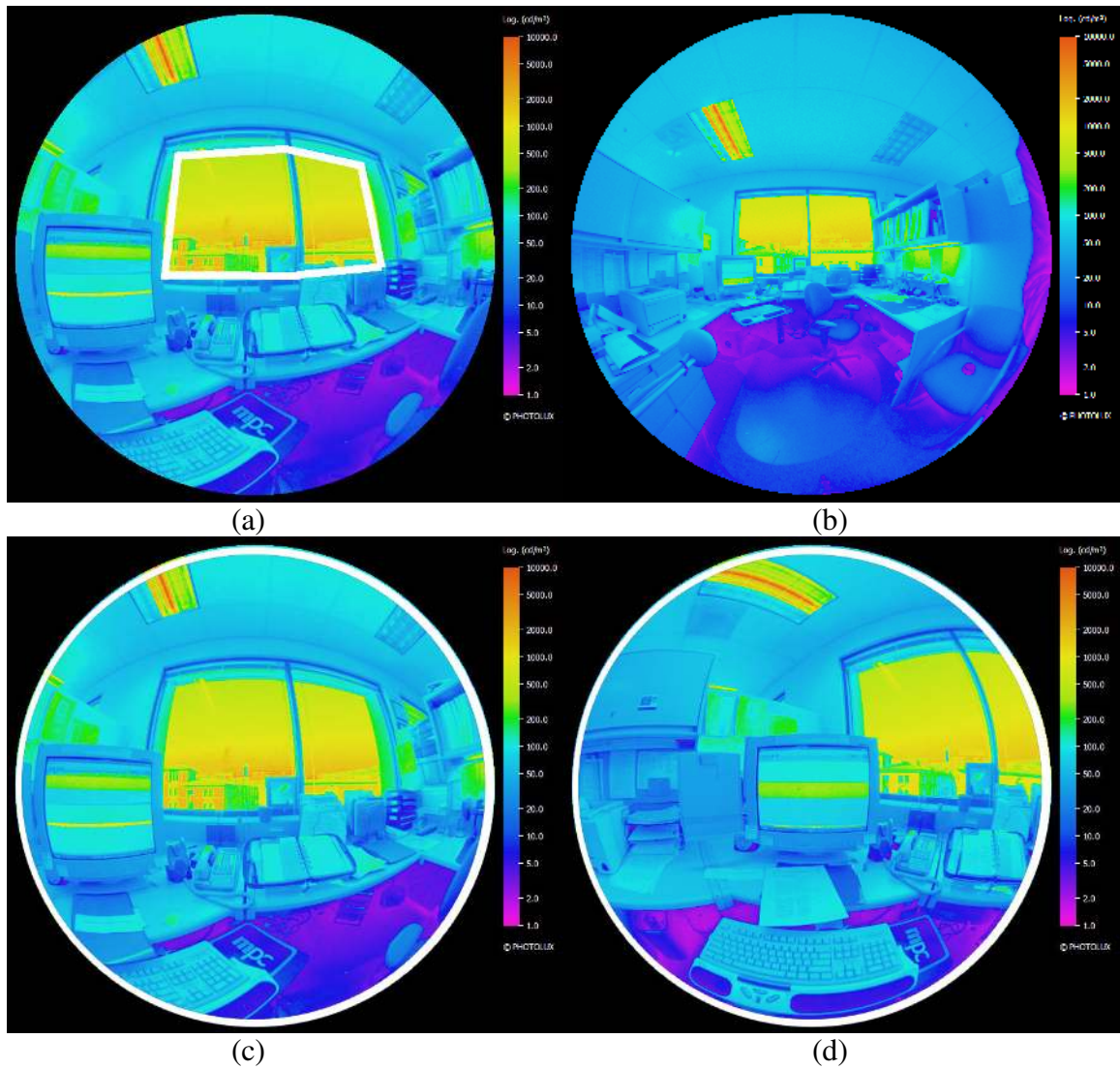

Figure 3.3 Examples of visual comfort variables from equidistant projection luminance maps: (a) average window luminance (L_{win}) and maximum window luminance (L_{mxwin}), (b) average window luminance from the back of the room (L_{win3}), (c) background luminance – window view (L_{glo1}), (d) background luminance – visual display terminal (VDT) view (L_{glo2})

3.2.3 Luminance ratio

In addition to visual comfort, the quality of interior illumination depends on the brightness ratios in the field-of-view (IESNA, 1947). The Illuminating Engineering Society of North America (IESNA) suggests that the eyes function most comfortably and efficiently when brightness ratios within the entire field of view are not excessive (IESNA, 1959). The underlying basis in the establishment of the luminance ratio guidelines is the physiological phenomenon called transient adaptation. In short, human eyes adapt themselves for improve visual sensitivity when moving from one luminance level to another by a photochemical reaction within the eye and by a change in pupil size. This compound effect is termed transient adaptation and takes a finite amount of time for completion (IESNA, 1987).

Transient adaptation is a phenomenon associated with reduced visibility after viewing a higher or lower luminance than that of the task. If recovery from transient adaptation is less than one second, neural processes are accounting for the change. If recovery is longer than one second, changes in the photopigments are accounting for the change (IESNA, 1984). If there are significant differences in appreciable areas of the visual environment, visual assimilation may be slower as the eyes move from one luminance level to another (IESNA, 1987).

Luminance in the visual field that surrounds an object or task can have different effects on visual ability depending upon the areas involved, their location with respect to the line of sight, and their actual luminances as compared with that of the task.

Luminance differences may produce a decrement in visual ability, visual comfort, or

both. For this reason, the luminance of the various surfaces in the visual field should be controlled and limited.

If there is a large difference in luminance between areas (a high luminance ratio), for example, a difference between the luminance of a task and that of a bright window during the day, then there may be a loss in the ability to see the task display if one looks away from the task to the window and then back at the task. If the luminance ratio is high, then there also may be a reaction of discomfort.

As a design guideline, specific luminance ratios have been recommended for various applications. For additional guidance, recommended upper and lower limits of a large area of surface reflectance are given for the same applications. The use of these reflectance limits, along with a selection of appropriate colors, can moderate luminances and keep them within ratio limits without creating a bland and uninteresting environment (IESNA, 1987).

The Illuminating Engineering Society of North America (IESNA) has begun recommending the luminance ratio for office lighting since their first edition (1947) of the lighting handbook. Current edition of the lighting handbook (IESNA, 2000) recommended maximum ratios as follow (see Figure 3.4):

- 1:3 or 3:1 between paper and VDT task
- 1:3 or 3:1 between task and adjacent surfaces
- 1:10 or 10:1 between task and surrounding surfaces

Other lighting design guides recommend similar values (Fordergemeinschaft Gutes Licht, 1992; CIBSE, 1994; Stein & Reynolds, 2000, Lechner, 2001).

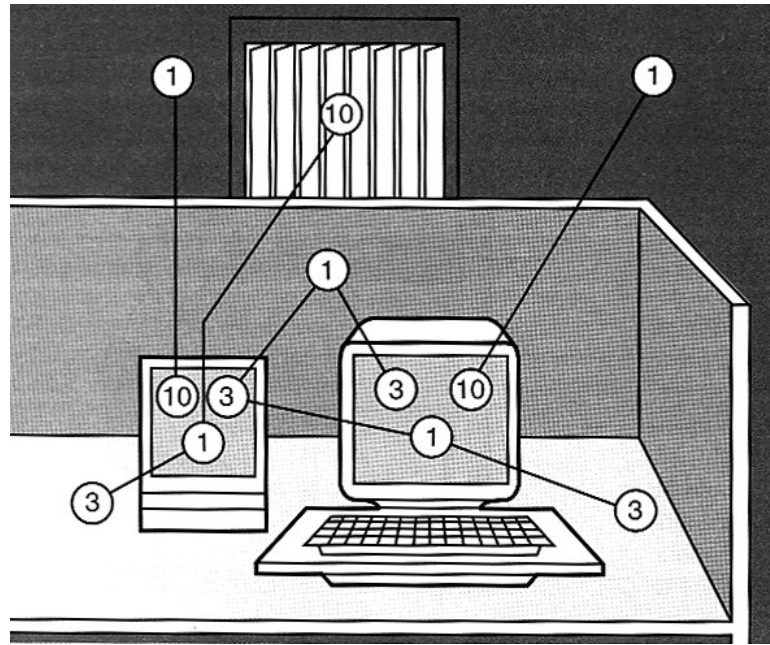

Figure 3.4 Maximum luminance ratios recommended for a VDT workstation. The values joined by lines illustrate the maximum recommended luminance ratios between various surfaces (from IESNA, 2000, p. 11-17).

While the luminance ratio has been cited in the previous literature as important to lighting quality assessment, the conventional use of luminance ratios has several known weaknesses. For example, the method of determining the luminance ratio lacks empirical support (Boyce, 1987; Berrutto et al., 1997; Veitch & Newsham, 2000). In addition, a clear definition of the surface areas (adjacent surface, surrounding surface, etc.) has not yet been provided. A few studies have suggested using luminance values within a 40° band (see Figure 3.7 & 3.8) to evaluate scene brightness (Loe et al. 1994; Veitch & Newsham, 2000; Cuttle, 2003).

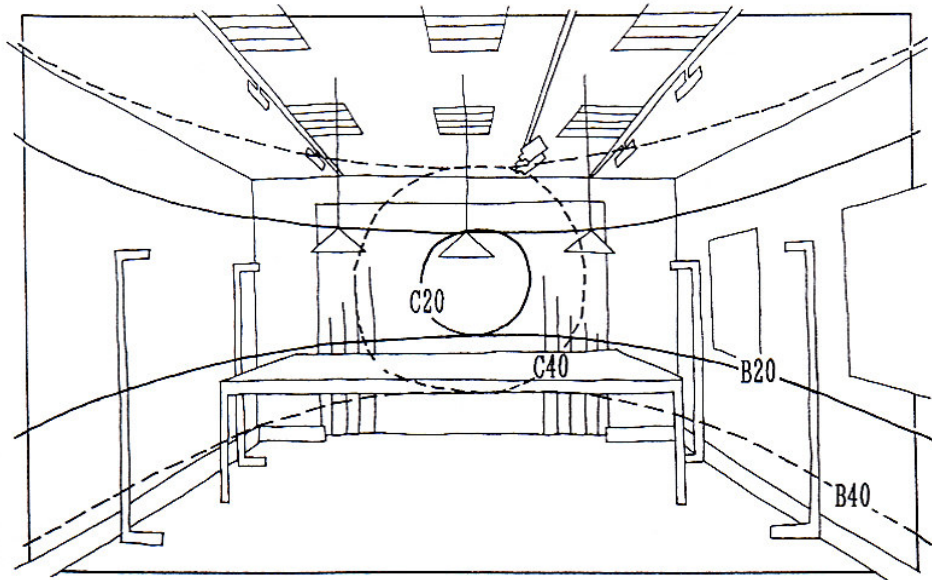

Figure 3.5 Diagram showing Loe's 40° horizontal field of view (after Loe et al., 2000)

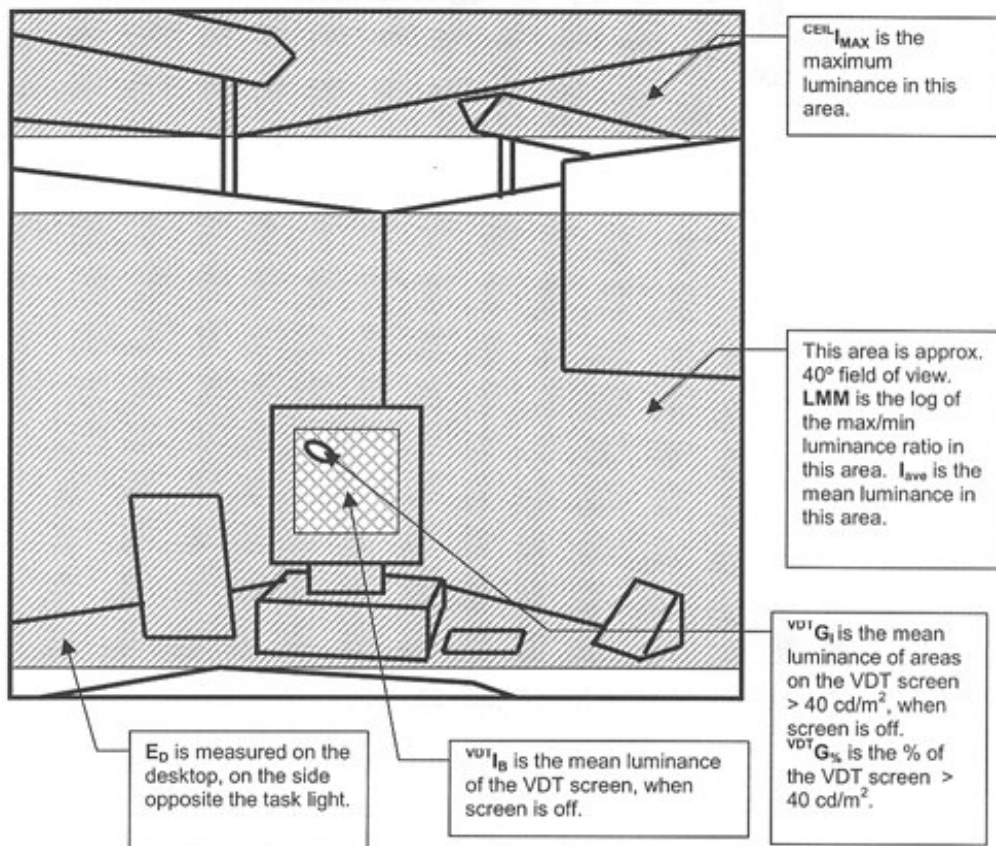

Figure 3.6 Diagram showing derived photometric values for the study of preferred luminous conditions, based on Loe's 40° band (after Veitch & Newsham, 2000).

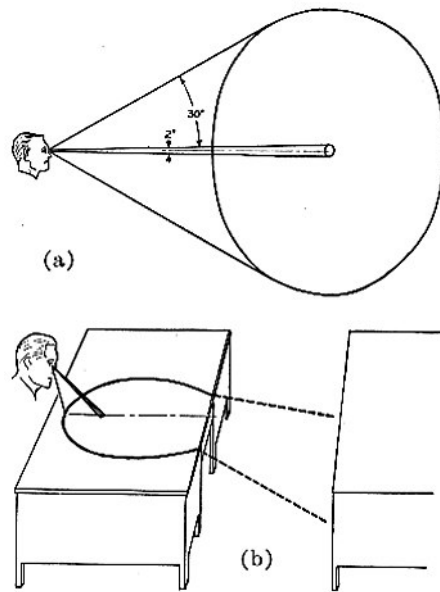

Figure 3.7 Central and surrounding fields of view: a) “heads-up” tasks, b) “heads-down” tasks (after IESNA, 1952).

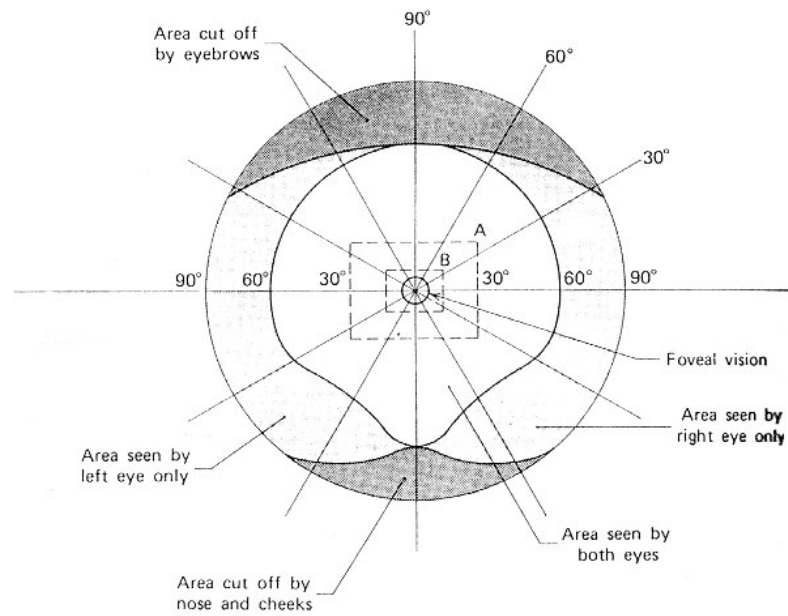

Figure 3.8 The field of vision of a normal pair of human eyes. The rectangles A and B superimposed on the field of vision represent a large magazine, a book or VDT screen (after Stein & Reynolds, 2000, p. 1066).

Realizing that an excessive luminance ratio might trigger window blind movement, the literature on VDT ergonomics was reviewed. It was discovered that both “heads-down” and “heads-up” tasks have a small central area, a cone about 2° wide (foveal vision) which the eyes see in detail, and a larger 60° cone representing the surroundings (see Figure 3.7 & 3.8). Because the human eye constantly scans, both of these cones move around the room. The actual and relative brightness of the task, its immediate surroundings, and anything else in the peripheral field of view affect visual comfort and task performance (IESNA, 1952). In the addition, it was found that typical VDT task takes about 10° to 30° of the central part of the visual field (IBM, n.d.).

Based on the literature review, the adjacent surface is defined as the area within 60° of the center of the visual cone (see Figure 3.9a), representing the adjacent area to which the eyes are sensitive. The surrounding surface is defined as the area within 120° of the center of the visual cone (see Figure 3.9b), representing the area that is seen by both eyes (binocular vision).

This research collected measurements of the following luminance ratio variables:

L_{mx60} Average luminance within 60° of the visual cone excluding luminance of VDT. The 60° visual cone is divided into two halves because the average of the whole visual cone may not accurately represent the discomfort conditions.

L_{mx120} Maximum luminance within 120° of the visual cone excluding luminaires

L_{vdt} Luminance of the VDT

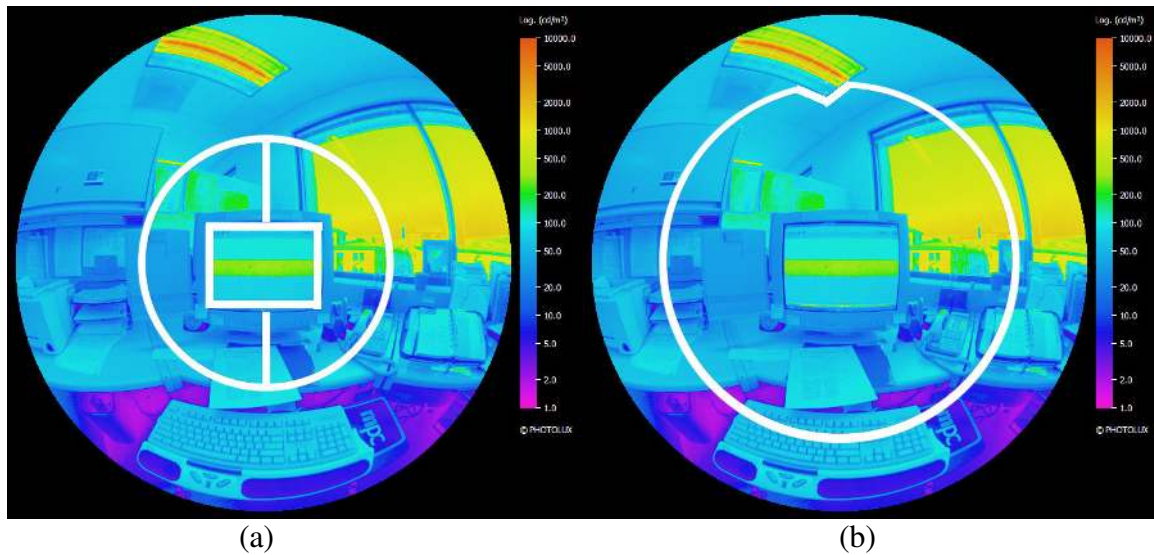

Figure 3.9 Example of luminance ratio variables from luminance maps: (a) average luminance of adjacent surface (within 60 degree cone of view) around VDT (L_{mx60}), and (b) maximum luminance within 120 degree cone of view excluding luminaires (L_{mx120}).

3.2.4 Thermal comfort

The thermal environment is typically described by four physical variables (air temperature, Mean Radiant Temperature, relative humidity, and air velocity), and two person-specific variables (thermal value of clothing and metabolic rate). These variables can be combined into values that represent the thermal sensations of building occupants such as Predicted Mean Vote (PMV) or Predicted Percent Dissatisfied (PPD).

In this field study, the assessment of thermal sensation was based on simple measures of indoor temperature (T_{air}), mean radiant temperature (MRT), and relative humidity (RH) at 3.6 ft (1.1 m) above the floor level. Brager and De Dear (1998) classified this type of instrumentation setup as Class III in which the data can be analyzed with simplified statistical techniques.

In the current research PMV/PPD was calculated by assigning a fixed value of air velocity (19.7 fpm), thermal value of clothing (0.9 clo), and metabolic rate (1.1 met).

PMV/PPD was calculated with the UC Berkeley Thermal Sensation Prediction Tool

(Fountain & Huizenga, 1997). The equation in this tool uses a steady-state heat balance for the human body and postulates a link between the deviation from the minimum load on heat balance effector mechanism and thermal comfort vote. In summary, the variables measuring thermal sensation are:

T_{air} Air temperature (°F)

MRT Mean radiant temperature (°F)

RH Relative humidity (%)

PMV Predicted Mean Vote

PPD Predicted Percent Dissatisfied

3.2.5 Subjective variables

The secondary hypothesis to be tested in this study is that there is a correlation between measured physical data and subjective comfort response. The current study utilizes Magnitude Estimation Method, originally developed by S.S. Stevens (1956), as the method of investigation.

In this method, Stevens asked research participants to assign numbers to their experiences of stimuli. Stevens (1975) showed that there was a consistent relationship between stimulus intensity and a number of different perceptions, such as loudness, apparent length, taste, smell, as well as brightness and thermal discomfort. Stevens (1975) established that sensation magnitude (Ψ) grows as a power function of the stimulus magnitude (Φ). This can be expressed as:

$$\Psi = k\Phi^\beta \tag{3.10}$$

The constant k depends on the units of measurement and is not usually taken into consideration. The value of the exponent β is unique; it differs from one sensory continuum to another as well as between individuals (Boyce, 2003; Stevens, 1975).

3.2.5.1 Visual comfort sensation

Stevens (1975) concluded that the power function exponents relating perceived brightness to luminance ranged from 0.33 to 1 depending on the temporal and spatial characteristics of the visual stimulus (Tiller & Veitch, 1995). Other researchers have suggested similar exponent values (Bodmann & La Toison, 1994; Marsden, 1970; Osterhaus & Bailey, 1992; Osterhaus, 1998).

A few subjective criteria have been established for the study of discomfort glare. These criteria include: the multiple criterion technique (Hopkinson, 1950; Hopkinson & Collins, 1970), the Borderline between Comfort and Discomfort (BCD; Luckiesh & Guth, 1949), and the Glare Sensation Vote (GSV; Iwata et al., 1990; Iwata & Tokura, 1998). All of these criteria are related. The Glare Sensation Vote follows Hopkinson's multiple criterion technique, and the BCD depicts the points that define comfort and discomfort (Veld, 1999).

The current research modified the Glare Sensation Vote (GSV) to include conditions when glare is not present or is imperceptible. The modified GSV_m and previously used glare criteria are shown in Table 3.2. To further separate the participants' feelings regarding sensation, discomfort, and acceptability, a new simple variable, L_{acc} , was developed. This variable was a measure asking about the acceptability of the lighting condition.

Table 3.2 Comparison of Different Glare Criteria

Degree of perceived glare	BCD	GSV	DGI	GSV _m
Imperceptible				1
Just perceptible		0	16	2
		0.5	18	
Just acceptable		1	20	3
Borderline between comfort and discomfort (BCD)	BCD	1.5	22	
Just uncomfortable		2	24	4
		2.5	26	
Just intolerable		3	28	5

3.2.5.2 Thermal comfort sensation

The current research used the ASHRAE seven-point category thermal sensation and McIntyre's (1980) thermal preference scale for recurring questions concerning subjective thermal comfort (see Table 3.3). Both scales have been widely used in previous thermal comfort research (Rohles & Nevins, 1971; Rohles, 1973; Schiller, et al., 1988). The ASHRAE scale is numbered from +3 to -3 with the center point at zero. The participants' feelings regarding thermal preference can be expressed through McIntyre's thermal preference scale where the participant can choose between want cooler, no change, and want warmer.

Table 3.3 ASHRAE Seven-Point Scale of Thermal Sensation and McIntyre Thermal Preference Scale

ASHRAE		Thermal Preference (McIntyre)
-3	Cold	Want warmer
-2	Cool	
-1	Slightly cold	Neutral
0	Neutral	
1	Slightly warm	
2	Warm	Want cooler
3	Hot	

3.2.5.3 Self-reported sensitivity to brightness and temperature

Accounting for physiological and psychological differences between individuals, variables called self-reported sensitivity to brightness (L_{sen}) and self-reported sensitivity to temperature (T_{sen}) were generated. At the end of the field study, each participants were asked to rate their sensitivity to light and temperature on a seven-point scale ranging from least sensitive (1) to most sensitive (7). It was hypothesized participants' self-reported sensitivity to brightness and temperature differ and they can be used as one of the criterion in window blind control models.

In summary, the current research measures subjective responses with the following variables:

- GSV_m Glare sensation vote
- L_{acc} Brightness preference
- TSV ASHRAE thermal sensation vote
- T_{acc} Thermal preference
- L_{sen} Self-reported sensitivity to brightness
- T_{sen} Self-reported sensitivity to temperature

3.2.6 Workplane illuminance

Workplane illuminance (E_{wrk}), measured at approximately 2.5 ft (0.762 m) from the floor, is perhaps the most widely-used parameter in lighting design. Minimum and maximum workplane illuminance values are recommended for various building types and task types to ensure that building occupants can perform different tasks at maximum

performance (IESNA, 2000). In addition, workplane illuminance has been used in previous research as a predictor for manually controlled and automated dimming systems. It was hypothesized that workplane illuminance can be used as a window blind control predictor. The locations of each illuminance sensor were chosen to monitor the amount of light that fell onto the horizontal surface (paper-task) with the least possible obstruction.

3.2.7 Transmitted vertical solar radiation at window

Previous research suggests that vertical solar radiation at the window (*SOL*) should be used as a predictor for window blind closing events (Inoue et al., 1988; Newsham, 1994; Reinhart, 2003). In this research, the vertical solar radiation was measured at approximately 4 ft (1.22m) from the floor, and the solar radiation sensor was mounted to the interior face of the window glass.

3.2.8 Confounding factors

There are many other variables that might influence the control of window blinds. Some of these variables, such as age, gender, façade orientation, etc., were included in the survey portion of the study, but were not taken into consideration in the field study portion due to a limited number of research participants and climatic conditions. The confounding variables that were analyzed in the field study include the direction of the VDT in relation to the window (*Divdt*) which participants were categorized as facing window and wall corner (Figure 3.10a) or facing sidewall or backwall (Figures 3.10b); the presence of direct solar penetration (*Disun*; Figure 3.11), and sky conditions (*SKY*).

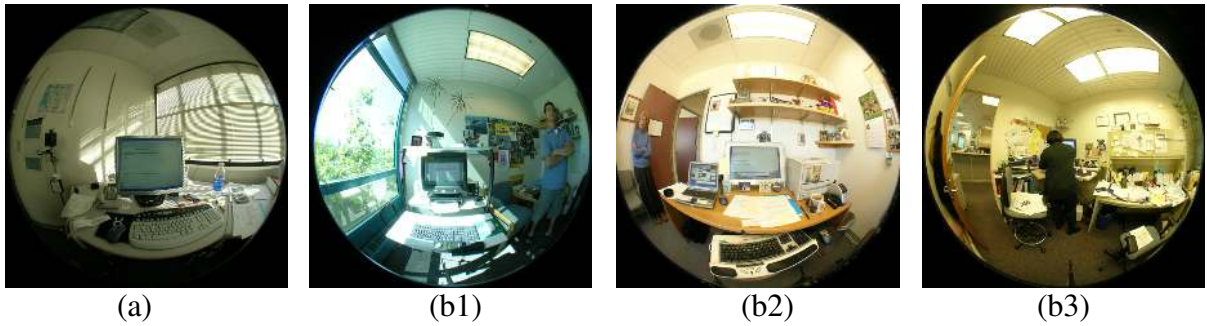

Figure 3.10 Direction of VDT in relation to window: a) window in the left/right half of the field of view; b) window on the left/right side of the occupants; c) and d) window to the back of the occupants.



Figure 3.11 Direct solar penetration categories: a1) direct sun falling on occupants, a2) direct sun falling on the room surface but not on occupants, b1) no direct sun (clear sky), and b2) no direct sun (cloudy sky)

3.3 Instruments

3.3.1 Window blind movement: Electronic sensors

The current research used a combination of a string potentiometer (Celesco PTX101; see Figure 3.12) and a single-axis tilt sensor (Crossbow CXTA01; see Figure 3.13 and 3.14) to measure blind position and blind slat angle. The string sensor was attached to the bottom of the blind. The tilt sensor was attached to one of the blind top slats to minimize cable length changes when the blind was raised or lowered.

Both sensors were powered with a 9 VDC regulated supply. The output signals were regulated to a maximum of 2.5 VDC. The output signals were monitored with a HOBO data logger (HOBO U12-013).



Figure 3.12 Installation of string potentiometer in the workspace. A common 1.5-inch U-bolt was attached to the bottom of the Venetian blind which created a connection point for the string potentiometer (left). The potentiometer unit was anchored to a wooden box, filled with a 4" x 4" concrete block. The potentiometer unit is portable and can be reused. The unit is painted black to blend with other office supplies (right).

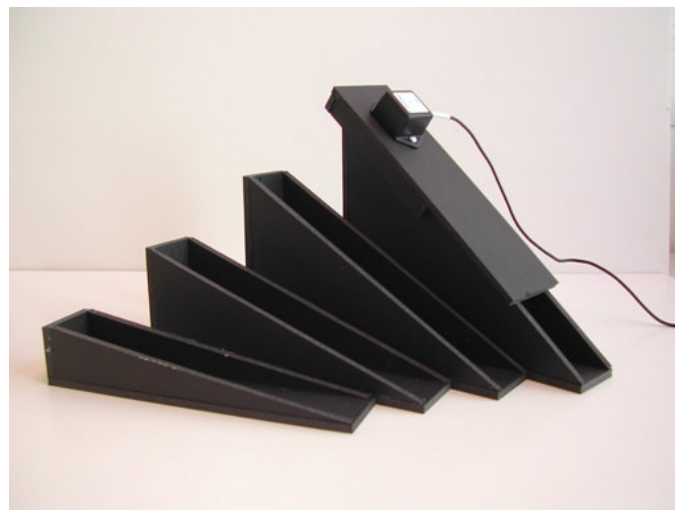

Figure 3.13 Tilt sensor calibration apparatus. Ten-degree increment slope platforms were created for tilt sensor calibration.

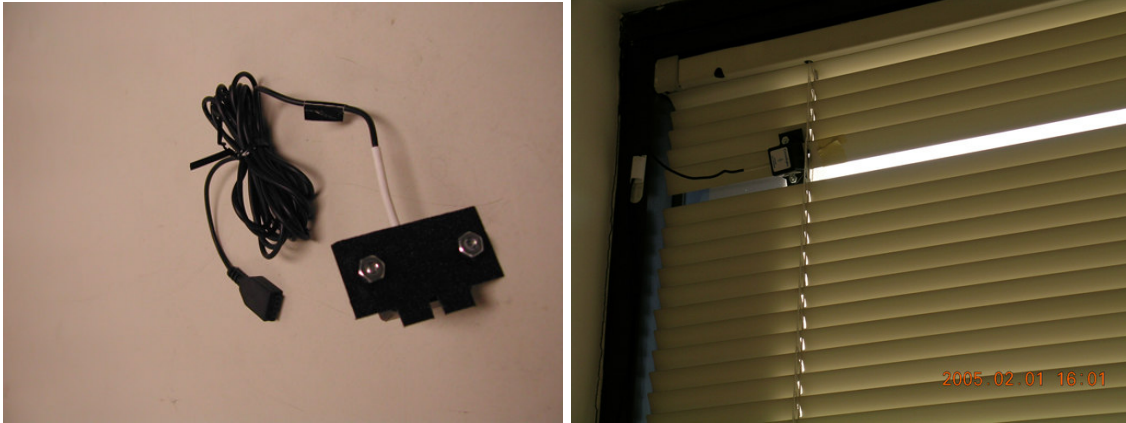

Figure 3.14 Actual installation of tilt sensor on Venetian blind. A piece of flat plastic was attached to the back of the tilt sensor with adjustable mechanical screw and nut (left). In the field study, the tilt sensor was attached to one of the blind top slats (right). A few slats below the sensor were taped together to allow full movement of tilt sensor.

Once downloaded to a personal computer, the voltage output signals were converted to the window blind position and slat angle variables. For the window blind position, the PTX101 provided a voltage output signal that was proportional to the linear movement of a traveling extension cable. The equation for the distance measure from the PTX101 is:

$$DISTANT(d) = \frac{(V_{out} - V_0)}{Sensitivity} \quad (3.11)$$

where

V_{out}	Output voltage
V_0	Zero distance voltage
$Sensitivity$	Sensitivity of string potentiometer

The CXTA01 provided a voltage output signal that was proportional to the sine of the tilt angle. For angles less than ± 20 degrees, the sine function can be approximated by a linear relationship between the V_{out} and the tilt angle (Φ) in degrees. The equation for determining the tilt angle in degree is:

$$\phi = \sin^{-1} \left[\frac{(V_{out} - V_0)}{Sensitivity} \right] \quad (3.12)$$

Example of calibration data from string sensors and tilt sensors are shown in Figures 3.15 and 3.16 respectively.

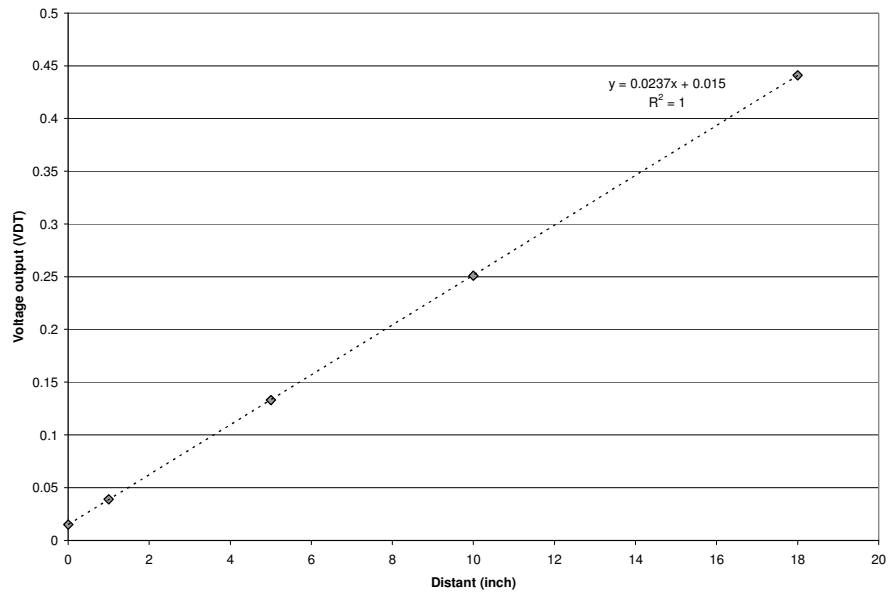

Figure 3.15 Typical voltage output from the string potentiometer.

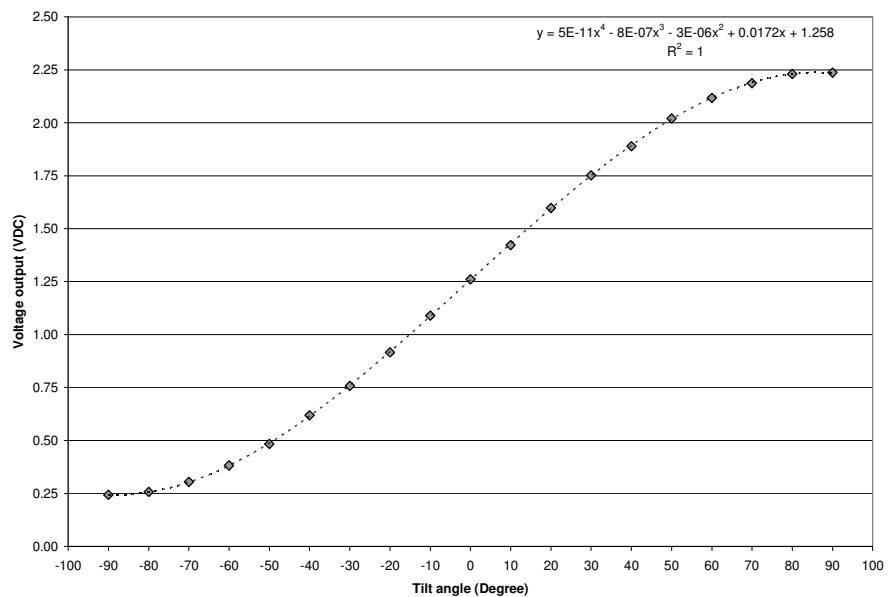

Figure 3.16 Typical voltage output from the tilt sensor.

3.3.2 Window blind movement: Time-lapsed photography

During the pilot study period, window blind movements were monitored from outside the building through time-lapse photography. Time-lapse pictures were manually taken with a digital camera at approximately two-hour intervals. The resolutions of the pictures were too coarse for identifying the window blind slat angle. The window blind occlusion level, however, could be identified into ten different steps (see Figure 3.17).



Figure 3.17 Window blind occlusion steps that were identified from time lapse photography (0 = fully opened, 10 = fully closed).

3.3.3 Luminance characteristics: Digital luminance map

3.3.3.1 Background

Traditionally, researchers rely on a handheld luminance meter as the primary method for documenting luminance distribution in field and laboratory studies. The photometric information gathered from the handheld device is a point-by-point measurement. While this method can be easily implemented, it has a few major disadvantages.

First, in order to document luminance characteristics of a large surface area, the measurement session usually takes a long time to complete. Second, the measured luminance values for a particular area may vary from point to point. The magnitude of variation will be greater for a surface that is not a uniform source (such as daylight window), for a surface that is not uniformly lit, or for a surface where the environmental conditions change rapidly. This can create systematic errors. Third, with a limited time to conduct the study in the field or in the laboratory, only a small number of data points can be collected at one time. Limited data points gathered from a large surface may be too coarse for a detailed analysis of luminance distribution.

To overcome the above-mentioned disadvantages, researchers have looked for a fast and easy way to document luminance distribution. The use of a camera to produce a luminance map was first proposed in the mid 1960s (Hopkinson et al., 1966). Two decades later, the Charge Coupled Device (CCD) camera, which is an integrated circuit with photosensitive cells, was produced (Coutelier & Dumortier, 2004). The CCD images have been used in other areas of scientific research. Because of high initial cost, only a handful of luminance measurement methods (based on CCD cameras) were developed for lighting/daylighting research.

One of the most recent CCD camera-based luminance measurement methods is the use of a Nikon Coolpix 5400 digital camera and Nikon fisheye lens FC-E9 with the Photolux Luminance Mapping system (here on refer to as the Photolux system) from the LASH/ENTPE, France (available as a licensed product).

The basic principle in generating a luminance map from Photolux is that the quantity of light which reaches the CCD is proportional to the aperture and to the time during which it was opened (Coutelier & Dumortier, 2004). In order to generate a luminance map, the scene of interest is photographed at multiple exposures.

Table 3.4 Combinations of Exposure Time/Aperture Settings that were Used to Create Luminance Maps.

	Exposure Time (Seconds)	Aperture (F)	Exposure Value (EV)	Approximate Luminance Range (cd/m²)
Picture #1	1/2	4	5.0	1-20
Picture #2	1/15	4	7.9	8-200
Picture #3	1/125	4	11.0	60-1500
Picture #4	1/1000	4	14.0	400-10000
Picture #5	1/2000	4	16.0	1500-30000

Table 3.5 Nikon Coolpix5400 Camera Settings that were Used to Create Luminance Maps.

Items	Setting
White balance	Daylight
Best shot selector	Off
Image adjustment	Normal
Continuous	Single
Saturation control	Normal
Sensitivity (ISO)	100
Image quality	Normal
Image size	5M (2592 x 1944 pixels)
Image sharpening	Off
Lens	Fisheye 1
Exposure option (AE lock)	Off
Auto bracketing	Off
Noise reduction	Off

The image produced by the digital camera comes with a set of RGB components. In order to get the luminance value, the CIE Lab color space, which defines a color based on its lightness (*L) and its chromaticity coordinates (a and b), is used for calibration

regardless of chrominance. The Photolux program converts color space from RGB to CIE Lab to get the luminance value. For each exposure values the CCD response was found to be a logarithmic function of the luminance. By superimposing multiple images with different exposure values, Photolux generates a luminance map with a wide range of luminance values (high-dynamic range).

One can foresee that the use of CCD cameras for lighting analysis purposes will increase in the near future because of several major advantages. First, the luminance documentation can be executed in less than 1 minute for a particular scene. Second, the photometric measurements are indirectly obtained from a spatial database rather than from a point-by-point spot measurement. A luminance map of the whole half hemisphere can be created, enabling researchers to look at a matrix of luminous data from the surface area. Third, the spatial quality of a luminance map enable researchers to retrieve the minimum, maximum, average, and standard deviation of luminance data from the smallest target area to the whole half-hemisphere. Luminance of a specific area within a complex scene can be manually segregated and any statistical values can be obtained. Lastly, the cost of a complete system is around \$1,200 which is much less than a typical handheld luminance meter such as the Minolta LS-110 (~\$3000).

3.3.3.2 Calibration

Prior to the field study, the accuracy of the Nikon Coolpix/Photolux system was evaluated by comparing the values captured by the Nikon and processed with Photolux against those measured by a spot luminance meter with $1/3^\circ$ field of view (Minolta LS-110).

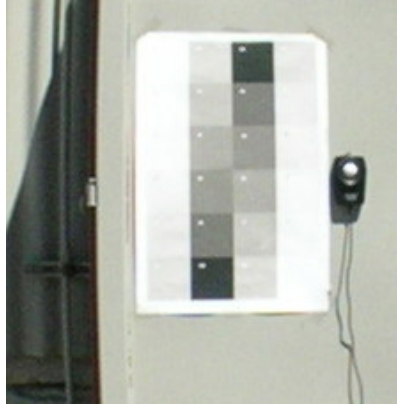

Figure 3.18 Gray-scale squares for the calibration of the Photolux system.

A series of 12 gray-scale squares was used as a target for calibrating the luminance data. The target consists of a single 13 x 19 in. (33 x 48 cm) sheet with 12-3 x 3 in (7.6 x 7.6 cm) squares of differing densities printed in an array across its face (see Figure 3.18). The target was drawn in Quark Express and printed on an Epson 1270 ink jet printer. Reflectance was measured with a Cosar 45 Reflectance Densitometer and a Minolta spot luminance meter (LS-110). The squares ranged in nominal reflectance from 4% to 87%.

The camera was mounted 4 ft (1.22 m) from the ground and located approximately 4 ft (1.22 m) from the center of the target. The target was also mounted 4 ft (1.22 m) from the ground (measured at the center) to align with the camera and to avoid any vignetting effect of the fisheye lens. In order to capture the widest luminance range possible and to simulate how the Photolux system may be used in the field, the target was mounted on interior and exterior vertical walls of buildings at the Lawrence Berkeley National Laboratory under three different luminous conditions: electric light only, diffuse sky, and direct sunlight (see Figures 3.19, 3.20, and 3.21).

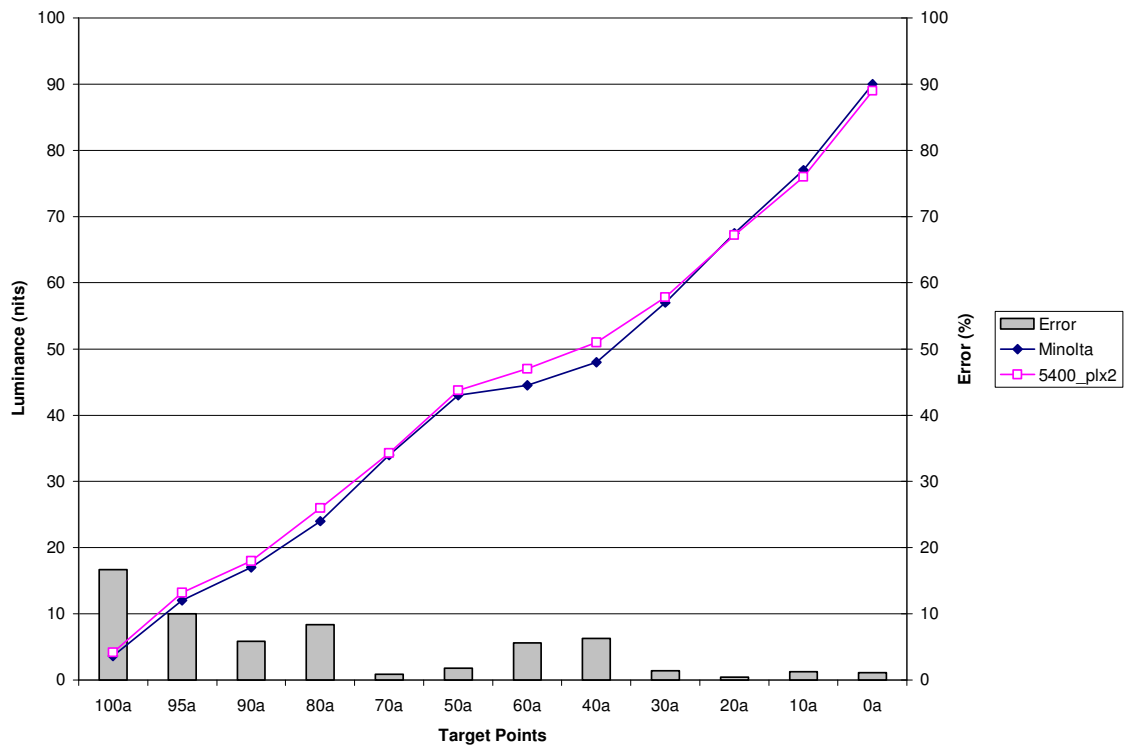
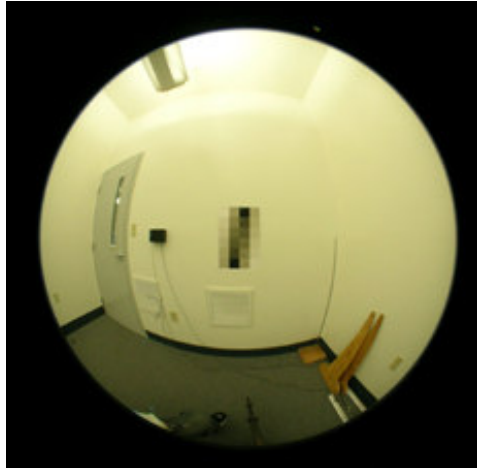

Figure 3.19 Comparison between captured and measured luminance values: Interior scene with electric light only (luminance range = 4 - 90 cd/m^2).

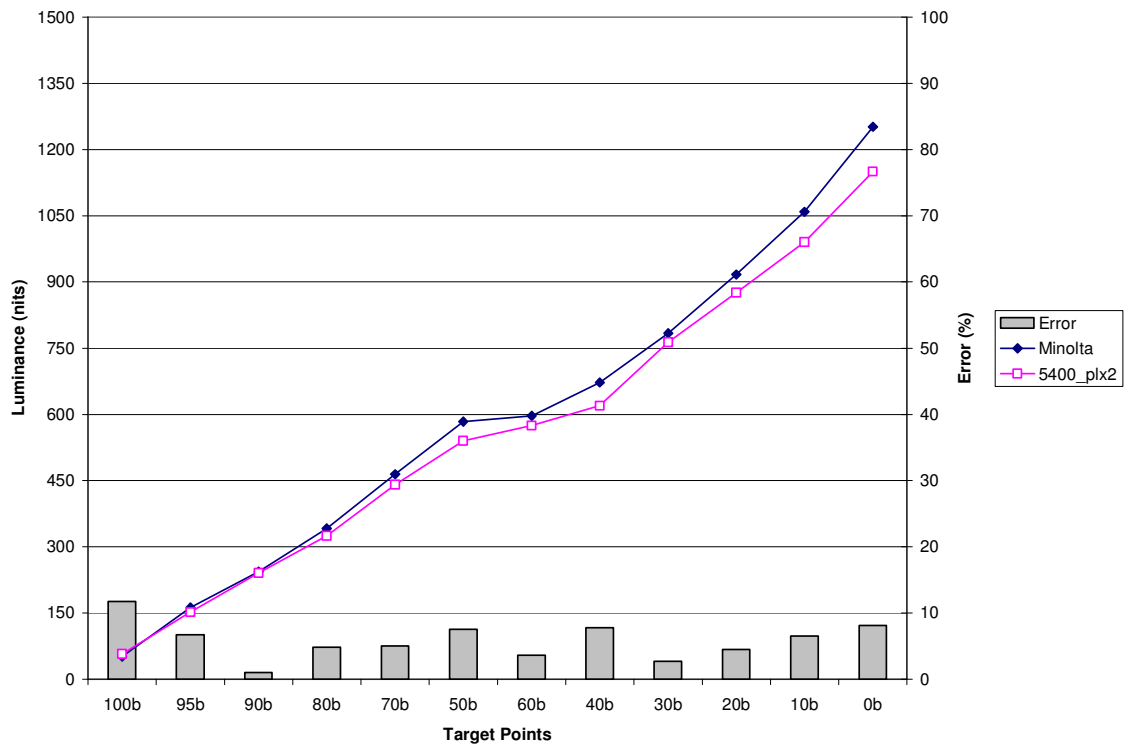

Figure 3.20 Comparison between captured and measured luminance values: Exterior scene with diffuse sky/no direct sunlight (luminance range = 60-1,200 cd/m^2).

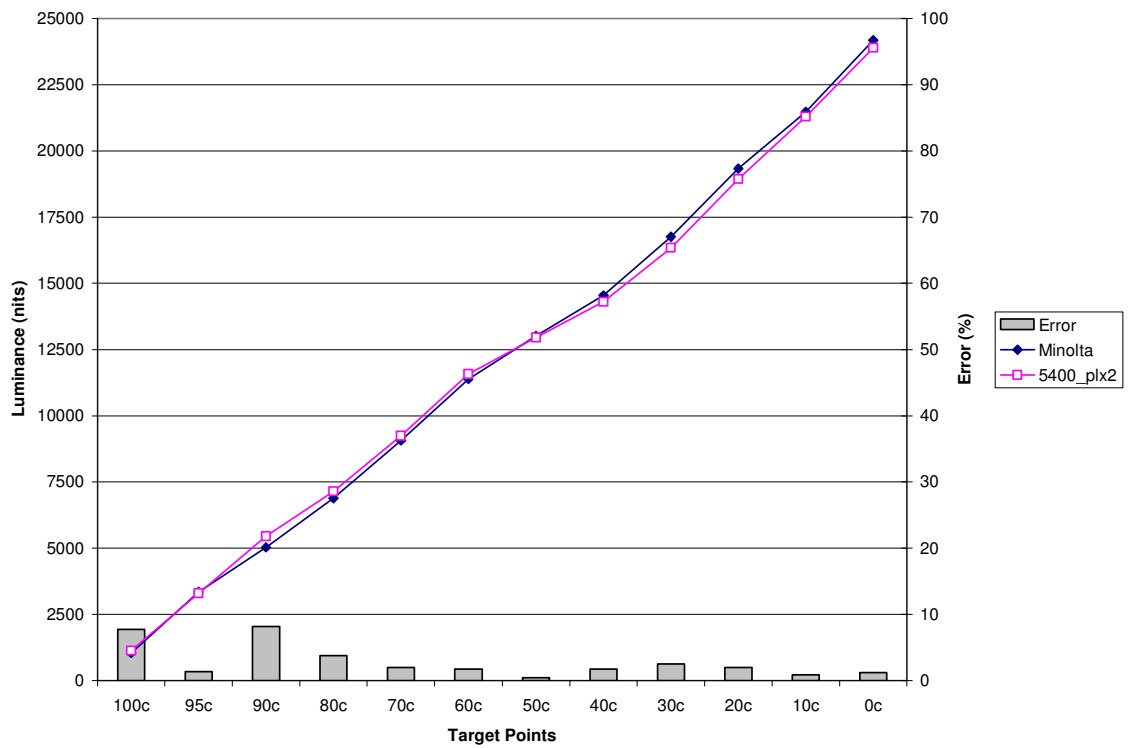

Figure 3.21 Comparison between captured and measured luminance: Exterior scene with direct sunlight (luminance range = 1,000-24,000 cd/m^2).

Publication No. 69 of the International Commission on Illumination (CIE, 1987) suggested that the expected error of the luminance values (collected from the best available commercial instruments) is 7.2%. These expected errors are from $V(\lambda)$ match (3%), UV response (0.2%), IR response (0.2%), directional response (2%), effect from the surrounding field (1%), linearity error (0.2%), fatigue (0.1%), polarization (0.1%), and errors of focus (0.4%). Given that there are two independent sources of error (the Minolta and the Photolux systems), the best agreement between two sources is expected to be on the order of 10% (the Root Mean Square (RMS) sum of two independent 7% errors).

The calibration data showed that the luminance values from the Photolux system were in reasonable agreement with the Minolta readings with the majority of error percentages below 10% (Figures 3.19, 3.20, and 3.21). However, the error percentages of darker target points (e.g., 95 and 100) are significantly higher than 10% in many scenes. These relatively low luminance points are prone to errors from bleaching, light scatter, and noise in the camera. It is concluded that the high error percentage that occurs with the darker target points may be a result of the “bleaching” effect of CCD chips.

Therefore, in the regression analysis (Figure 3.22 and 3.23), the luminance values from the two highest target density points (95 and 100) were excluded from the analysis. Because the data range of 10 to 24,000 cd/m^2 is very large, the standard assumption for linear regression of equal expected error for all data points is invalid. Therefore a log-transformation was performed for all data points to convert the equal relative errors to equal absolute errors before doing the linear regression. A high correlation between measured and captured log-luminance data was found ($r = 0.99, p < .01$).

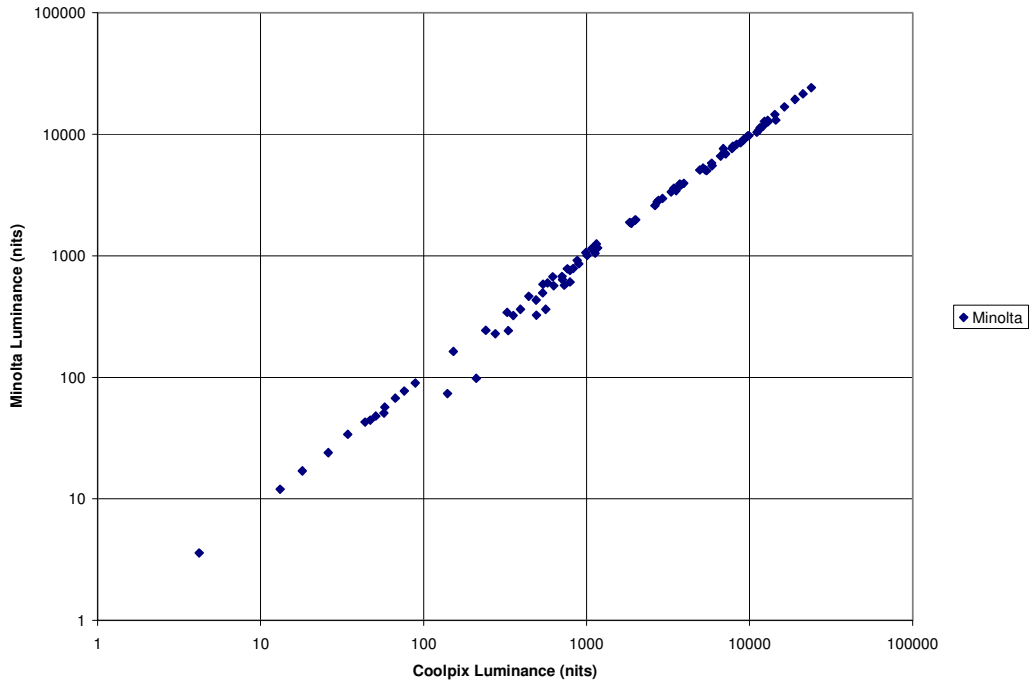

Figure 3.22 Scatter plot of measured and captured absolute luminance values: All data points.

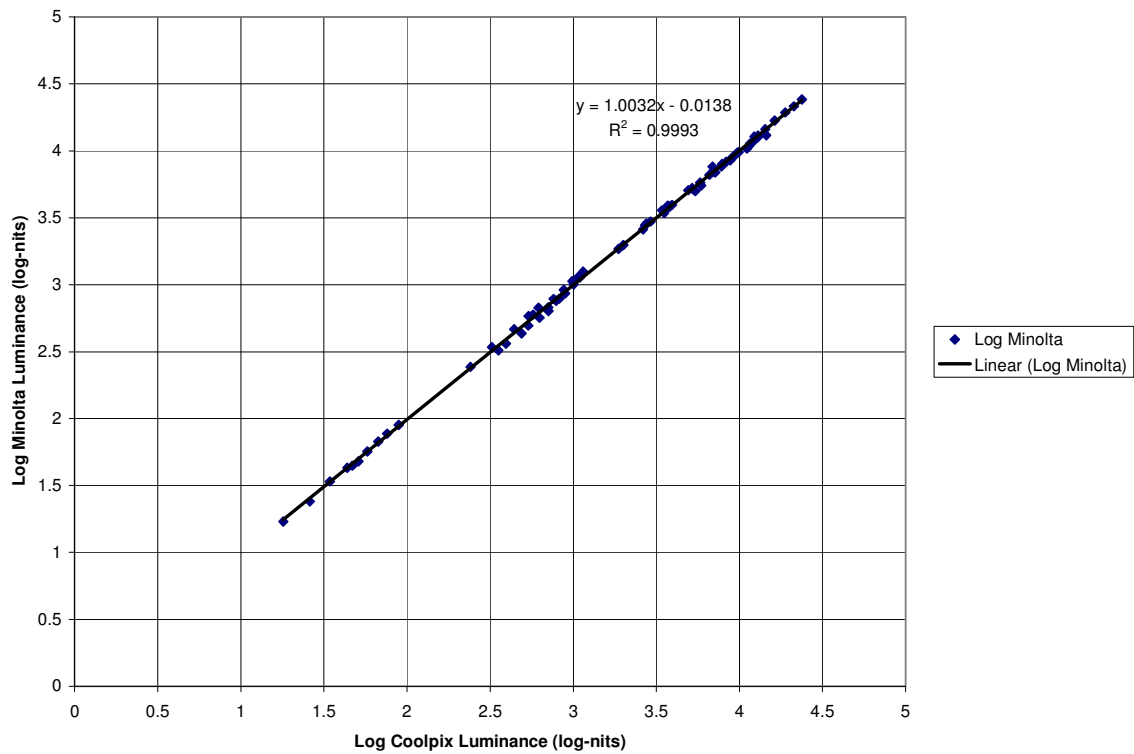

Figure 3.23 Scatter plot of measured and captured log luminance values: Excluding 95 and 100 target points.

3.3.3.3 Vignetting characteristics

Vignetting refers to the decrease in illumination towards the edge of an image. Vignetting is a normal characteristic and is most obvious at wide-open apertures, especially with a wide-angle lens. The current research examined vignetting characteristics as they were influenced by the intrinsic properties of camera optics. It is anticipated that the luminosity in the middle part of the photograph will be higher than those at the edge of the photograph. Ideally, the Photolux system should automatically compensate for any vignetting characteristics for the fisheye lens that was used in the original calibration.

In order to evaluate the vignetting characteristic of the fisheye-lens used in this study, a series of luminance values of a fixed target were captured in a controlled laboratory environment. The target was a piece of white copy paper (reflectance = 0.90) mounted on a vertical wall 2.74 meters (108 inches) from the camera. The target was lit by a typical slide projector. Assuming that the vignetting characteristic was radially symmetrical, the camera was rotated with respect to the target at 5-degree intervals until half of the camera's field-of-view was covered. Readings were collected representing angles of incidence from 0° to 90°.

The luminance values of the target at 5-degree increments were gathered from the luminance maps generated by Photolux system. These luminance values were plotted as a function of the cosine of a given angle, resulting in the vignetting characteristic along the radius of the fisheye lens.

The data showed that there was a 12 % luminance loss at the edge of the picture (see Figure 3.24). The estimated vignetting characteristic was calculated as a polynomial function as follows:

$$y = -0.3347x^4 + 0.988x^3 - 1.0978x^2 + 0.5631x + 0.8771 \quad (3.13)$$

where

y Relative luminance (calculated from maximum at center)
 x Cosine of degree deviation from normal

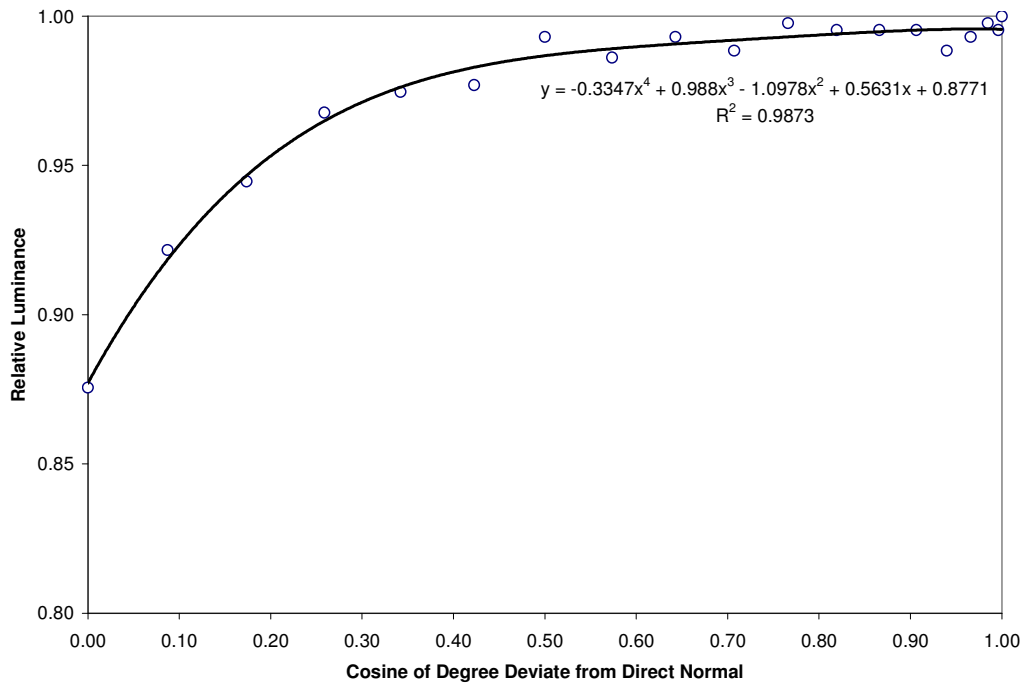

Figure 3.24 The vignetting characteristic of the fisheye lens FC-E9. The relative luminance values are plotted as a function of the cosine of degree deviation from normal.

As an end-user, correction of a vignetting characteristic cannot be executed. It is anticipated that a digital correction filter could be created to compensate for the differences. Because the luminance analysis focuses on the middle section of the image (presumably to simulate the binocular vision within the 120° visual cone), the relatively low luminance loss rate (10% at 80° and 12% at 90°) was considered to be insignificant for luminance analysis in this study.

In summary, the camera was calibrated under various lighting conditions. For the conditions that were examined, the camera and the Photolux software appeared to be capable of capturing luminance with a moderate accuracy (within 10% of those measured by a standard luminance meter).

In the current research, the majority of luminance values were taken from the area within the 120° visual cone (binocular vision). For background luminance values, where the luminance from the whole visual field was considered, the accuracy level could be lower than ideal. It was expected that the overall level of accuracy would not fall below $\pm 10\%$.

3.3.3.4 Camera viewpoints

Workspaces were manually photographed from 2 viewpoints: the seating area looking at the window wall and the seating area looking at the VDT (see Figure 3.25). These two viewpoints were chosen under the assumption that building occupants spend most of their time on the computer tasks and occasionally look out through the window.

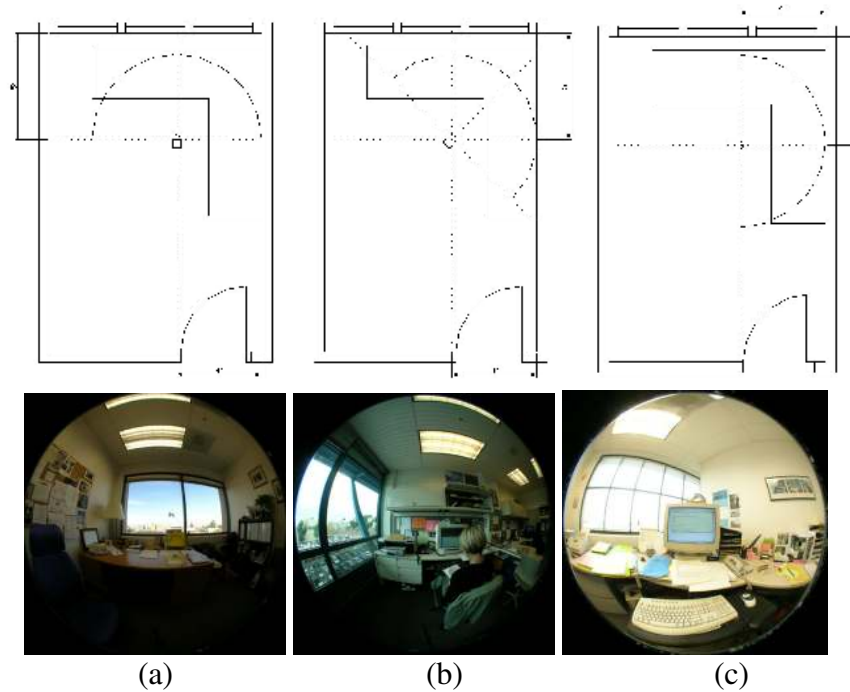

Figure 3.25 Digital camera viewpoints: (a) looking directly at window; (b) and (c) looking at VDT screen.

3.3.4 Window and background luminance

During passive observation periods, window luminance, adaptation luminance, workplane illuminance and solar radiation at the window were measured and collected with Li-Cor Photometers (LI-210) and a Li-Cor Pyranometer (LI-200). These sensors were connected to a Campbell Scientific 21X data logger. The Campbell 21X is a stand alone data logger which controls the timing and sequence of sensor polling, processes signals, and stores processed data in its internal memory unit.

In the current research, the Campbell 21X was programmed to collect data at 6-minute intervals for all sensors. At the end of each session, the data were downloaded from the Campbell 21X to a personal computer for further data analysis.

The window and background luminance monitoring method was adapted from the Aizlewood's (2001) method that was described in section 3.3.2. A Li-Cor photometer was mounted in the center of a matte black wooden box 4 ft (1.22 m) from the floor. The 4 ft (1.22m) height was selected to emulate the height of the normal human eyes in sitting position. Another Li-Cor photometer was mounted on top of the wooden box at 4 ft 2 in (1.27 m) from the floor. The "luminance" box was mounted on a free-standing pole (Figures 3.26 and 3.27). The sensor poles were usually placed at the back of the room due to space constraints. The light-admitting side of the box was covered with a removable shield. The opening of this removable shield was scaled by the configuration factor to detect only the average luminance of the window. From these data, average window luminance could be derived.

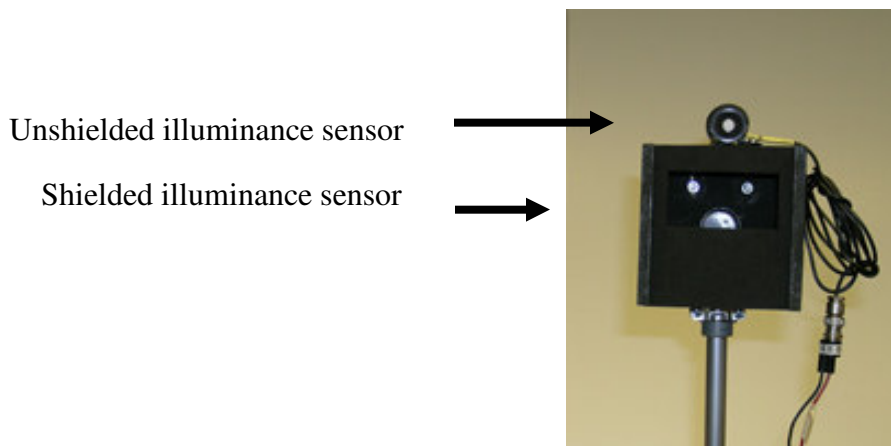

Figure 3.26 Shielded and unshielded illuminance sensors mounted on a free-standing sensor pole.

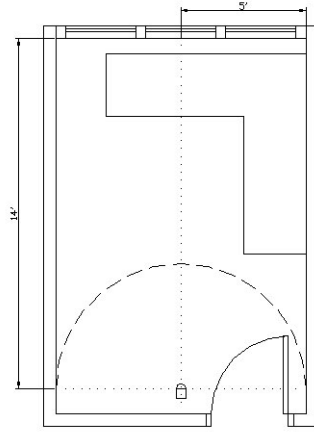

Figure 3.27 Example location of a free-standing sensor pole. The sensor poles were usually placed at the back of the room due to limitations in space.

Based on the principle of luminous flux transfer (IES, 2000), the average window luminance was calculated using the following equation:

$$L_s = \frac{E_{shielded}}{\pi \cdot \phi} \quad (3.14)$$

where

$E_{shielded}$ Average vertical illuminance from shielded illuminance sensor (lux)

Φ Configuration factor of source in respect to the measurement point

The configuration factor Φ was estimated using the following equation:

$$\phi = \frac{A \arctan B + C \arctan D}{2\pi} \quad (3.15)$$

where

$$A = \frac{X}{\sqrt{1+X^2}} \quad (3.16)$$

$$B = \frac{Y}{\sqrt{1+X^2}} \quad (3.17)$$

$$C = \frac{Y}{\sqrt{1+Y^2}} \quad (3.18)$$

$$D = \frac{X}{\sqrt{1+Y^2}} \quad (3.19)$$

$$X = a/c \quad (3.20)$$

$$Y = b/c \quad (3.21)$$

- a Height of the window
- b Width of the window
- c Perpendicular distance from sensor to window (Figure 3.328).

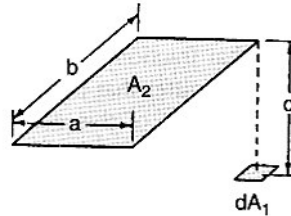

Figure 3.28 Dimension for the calculation of configuration factor (from IESNA, 2000).

The adaptation luminance is given by:

$$L_s = \frac{E_{unshielded}}{\pi} \quad (3.22)$$

Workplane illuminance, vertical solar radiation at the window, and global solar radiation were collected directly from the Campbell 21X without any mathematical manipulations.

3.3.5 Temperature and relative humidity

Temperature and relative humidity data were gathered from a HOBO standalone data logger (HOBO H8-007-02) equipped with narrow-range temperature sensor cable (HOBO TMC6-HB). Each air temperature sensor probe was housed inside a cylindrical Mylar radiation shield (1.5- inch diameter) to protect the probe from direct radiation gain. For globe temperature, each temperature sensor probe was placed inside a 1.5 in. (38mm) ping pong ball which was previously spray-painted matte gray.

The HOBO data logger and temperature probes were mounted to a wooden box 3.6 ft (1.10 m) from the floor. The 3.6 ft (1.10 m) was chosen to measure the temperature at the neck position of a normal person in sitting position. This “temperature” box was attached to same free-standing pole that the “luminance” box was attached to (see Figure 3.29).

Mean Radiant Temperature (MRT) values were approximated from the globe temperature and the air temperature. The equation for MRT under still air was:

$$MRT = T_a + [(T_g - T_a) \cdot 2] \quad (3.23)$$

where

T_{air} Air temperature

T_{globe} Globe temperature of the 38mm ping pong ball sensor

According to the manufacturer (Onset Catalog No. 22), the accuracy of the HOBO H8 is $\pm 0.7^\circ\text{F}$ at 68°F ($\pm 0.4^\circ\text{C}$ at 20°C) with a resolution of 0.3°F at 68°F (0.2°C at 20°C). The accuracy for measuring relative humidity is $\pm 0.5\%$ over the range of 41°F to 122°F (5°C to 50°C).

“Luminance” box
“Temperature” box
“Occupancy” box



Figure 3.29 Pictures of the instruments in the field. The “lighting” box and the “temperature” box were attached to a free-standing pole at 4 ft (1.22m) and 3.6 ft (1.10m). The occupancy sensor was also mounted to the same pole. The opening of the “lighting” box was positioned to measure average window brightness (left)

3.3.6 Occupancy

The presence or absence of occupants was recorded using a portable motion detector (Radio Shack #49-426). The method, adapted from the Building Science Laboratory at UC Berkeley, included the use of an off-the-shelf infrared motion detector, modified for use with a HOBO logger (HOBO H8 or U12) with Voltage input cables (2.5 mm Stereo Cable).

In chime mode, the motion detector sent a short voltage signal to the speaker when it sensed motion. In the current study, the motion detector unit was integrated with a circuit utilizing a capacitor charged by the voltage signal from the motion detector. When occupancy is indicated by a sensed motion, the capacitor instantaneously charges to about 2.5 volts and then leaks current over an extended period of time. This voltage leakage allows voltage readings to be taken at a discrete interval while preserving the

capacity to determine whether a motion "hit" had occurred since the previous voltage reading. A typical signal output from occupancy sensor unit that was activated once at minute 0 is shown in Figure 3.30.

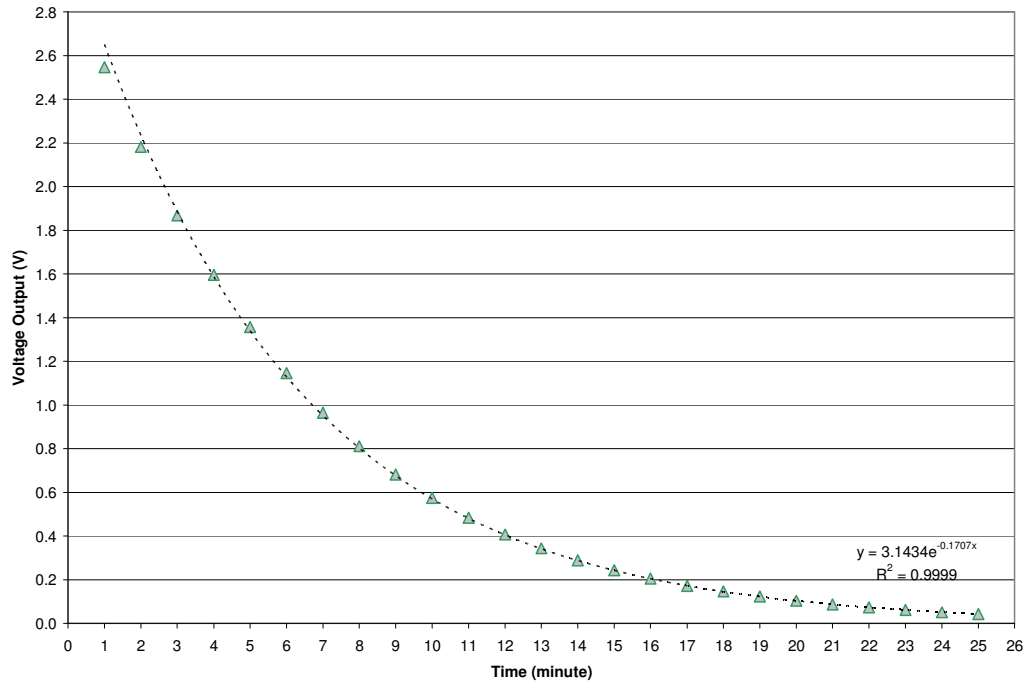

Figure 3.30 Graph of a typical voltage discharge of occupancy sensor capacitor.

The occupancy sensor unit was attached to the free-standing pole as shown in Figure 3.29. In order to detect whether the office building occupant occupied the space or not, the occupancy sensor was positioned to register only the building occupant in the workspace.

3.4 Procedure

Prior to conducting the survey and field study, the research protocols were submitted to the UC Berkeley's Committee for the Protection of Human Subjects (CPHS) and the LBNL's Human Subjects Quality Assurance Committee. Exemptions were granted in November 2002 and January 2004 (CPHS 2002-11-42; Appendix A). The updated protocol was reviewed and approved in October 2004 (CPHS# 2004-10-37; Appendix B)

3.4.1 Participant recruitment

Recruitment for the window blind usage survey and field study began with discussions with the appropriate organization managers, building owners, and/or facility managers. A solicitation to participate in the study was sent directly to prospective participants via e-mail. When contacted by a potential participant, a more detailed package of information was sent explaining the study, general procedures, and the time it would take to participate. Participants were asked to read and sign the study's informed consent forms prior to their participation. A copy of the form was given to participants for their records.

3.4.2 Participant selection criteria

Participants were recruited for the study if they have Venetian blinds installed and were able to control their window blinds and worked in: a cubicle, a private office, or a shared office (2-4 people in one office).

3.4.3 Participation

Prior to the actual survey, two versions of pilot web-based survey were assessed by thirty two experts in the field of lighting from the Lawrence Berkeley National Laboratory, the National Research Council Canada, the UK's Building Research Establishment, and the Rensselaer Polytechnics Institute's Lighting Research Center. In addition, the pilot surveys were administered to twenty novice users in the U.S. through personal contacts. The current window blind usage surveys (Appendix C - F) were modified according to the feedback and comments from expert and novice users. The feedback and comments addressed formulation of survey questions, ease of use, and time spent filling in the survey.

This research reports survey results from a total of 187 respondents from the different organizations in Berkeley, California, in which 113 respondents met the participant selection criteria mentioned in section 3.4.2. Because the recruitment and solicitation were initiated through email, response rate could not be verified.

For the field study, approximately 52% (60 people) of the qualified respondents expressed willingness to participate in the field study. Results were obtained from a total of 25 building occupants from two office buildings in Berkeley, California.

3.4.4 Preliminary building selection criteria

The criteria used for the preliminary selection of buildings were:

1. The Venetian blinds should be standard light-colored (white or light-gray) and 1 inch (25mm) in width.

2. The offices should have similar interior surface reflectance (ceiling = 0.6-0.8; wall = 0.4-0.6; floor = 0.2-0.4).
3. The offices should have similar decorations (furniture, color, conditions, etc.).
4. The offices should have similar size windows.
5. Physical characteristics of glazing, such as visible transmittance (VT) and solar heat gain coefficient (SHGC), should be similar (VT = 0.4-0.7; SHGC = 0.4-0.7).

3.4.5 Window blind usage survey

A window blind usage survey (Appendix C) was created to gather information regarding how and why building occupants control their window blinds. The survey also asked participants to rate their satisfaction with the environmental quality of their workspace. The majority of the questions were multiple-choice, with a few open-ended questions. The questions are divided into three major sections:

1. Background information. This section measured characteristics of participants' workspaces such as private vs. open-planned office, glass type, and demographic information.

2. Window blind usage. This section measured the frequency of window blind usage and the reasons for operating window blinds.

3. Satisfaction with lighting and thermal environment. This section measured discomfort and overall satisfaction with the lighting and thermal environment.

Questions in the first and third sections of the survey were standard items that can be found in many post-occupancy evaluation studies (Maran & Sprekelmeyer, 1982; Maran & Yan, 1989; Sander & Collins, 1995; Escuyer & Fontoyntont, 2001; Moore et al., 2004). The questions in the second part of the survey were developed from previous research on lighting and window blind control (Inoue et al., 1988; Vine et al., 1998, Velds, 1999).

For a few of the questions, “Other. Please specify,” was provided as an alternative option. This gave participants the option to express opinions that were not present in the set of given answers. In addition, at the end of the survey, there was one open-ended question asking participants about other issues that were not taken into consideration in the survey.

This study utilized the web-based survey engine, developed by the Center for the Built Environment (CBE) at the University of California, as the main method for data collection (Zagreus, Huizenga, & Arens, 2004). This web-based survey engine has an “automated branching” capability which enables participants to skip irrelevant questions, based on answers to previous questions. It took occupants between 5-15 minutes to complete the survey, depending on the question branching-sequence. Once invited, participants were given two weeks to submit the survey. Upon completion of the survey, one out of every 20 participants was randomly selected to receive a \$20 gift certificate.

3.4.6 Window blind usage field study

The field study portion of the research monitored window blind movements in relation to lighting/thermal environmental conditions. The duration of the field study was

approximately five workdays to cover various sky conditions. A typical field study schedule is described in Table 3.6. In this study, window blind control models were derived from data on Day 5.

Upon completion of the field study, each participant received a \$20 gift. Those who participated in both parts of the study were entered to win the gift certificate for the survey and then received an additional \$20 gift certificate for the field study.

Table 3.6 Typical Field Study Schedule

Day	Procedure
Day 1: Instrument set up	The instruments were transferred to the participant’s workspace and were assembled on-site. Installation took about 15-30 minutes.
Day 2-4: Passive observation	<p>Participants were asked to perform normal working tasks during the day and operate the window blinds as they normally do. Data logger instruments automatically recorded blind movement patterns and lighting/temperature conditions at six-minute intervals.</p> <p>Each day participants were asked to perform the following tasks:</p> <ol style="list-style-type: none"> 1. Upon arrival, pull the blind all the way up. Participants were asked to lower the blind down to a desired position when the interior environmental conditions become just uncomfortable for performing normal working tasks. 2. Each day, participants were asked to fill in at least two short web-based surveys (Appendix D) asking how and why they used window blinds during that particular day (3 minutes per survey).
Day 5: Real-time assessment of lighting/temperature conditions	<p>Participants’ workspaces were manually photographed with a digital camera. Simultaneously, participants were asked to answer questions on a short web-based survey (Appendix E) regarding their satisfaction with the lighting/thermal environment.</p> <p>The scheduling of the photography session was approximately every two hours during normal work hours. Participants were allowed to reschedule appointments at anytime.</p>
Day 6: Instrument Retrieval	Sensors and data loggers were retrieved. Participants were asked to report their sensitivity to brightness and temperature on a short paper-based survey (Appendix F)

3.5 Data processing and analysis

The data analysis process began by arranging the data into a series of rows for each response. Then the data set was inspected for anomalies. Missing values, extreme values, or incomplete values were rechecked, re-entered if appropriate, or reported as missing. Once inspected, the data files were sorted and split into smaller files to reduce the file size. Basic descriptive statistics were calculated in Microsoft Excel. Advanced statistical analyses were conducted with SPSS and STATA. It was determined that many of the physical environmental variables were not normally distributed. Therefore, a log-transformation technique was applied to these variables.

3.5.1 Survey data analysis

The original survey data were collected in Microsoft Excel. Because survey data were typically nominal and ordinal, non-parametric statistics methods such as Chi-square test and Fisher's Exact test were used to test for significance.

3.5.2 Field study data analysis

The field study data set consists of data collected from various instruments over an extended period of time (longitudinal data). After the data sets (from Campbell 21X, HOBO, and UCB Comfort Program) were converted into MS Excel format, they were merged into one data file with a long data structure for analysis with STATA. In the long data structure set each participant had as many data records as there were measurements over time (Twisk, 2003).

3.5.2.1 Longitudinal data analysis

Longitudinal logistic regression techniques played a major role in the derivation of predictive window blind control models in this research. Logistic models have been used in previous research to explain control behavior for electric lights, windows, and blinds (Hunt & Crisp, 1978; Hunt, 1979, 1980; Love, 1998; Nicol, 2001; Reinhart, 2003).

A logistic model is appropriate because:

1. The estimated dependent variable lies in the range between zero and one (window blind either closed or opened).
2. The combined effect of several factors on window blind control behavior form an elongated S-shaped distribution.
3. The threshold value can be measured at $p = 0.5$.

The basic logistic model is expressed as:

$$P(X) = \frac{1}{1 + e^{-(\alpha + \sum \beta_i X_i)}} \quad (3.24)$$

where α and β are estimated regression coefficients

For continuous outcome variables, in addition to the standard regression analysis, longitudinal linear regression analysis was used to identify relationships between outcome variables and predictor variables. This was the case in the field study where the measurements were repeatedly taken from each participant over time.

The relationships between dependent variables (dichotomous and continuous) and independent variables were analyzed with Generalized Estimating Equations (GEE). GEE is an iterative procedure, using quasi-likelihood to estimate regression coefficients (Liang & Zeger, 1986; Hardin & Hilbe, 2003). With GEE the relationships between the variables of the model at different time-points are analyzed simultaneously.

The within-subject correlation is treated as a covariate variable (Kleinbaum & Klein, 2002). Therefore, the estimated regression coefficients reflect relationships between independent and dependent variables using all available longitudinal data (Twisk, 2003). The regression coefficients calculated with GEE analysis are considered as population averages (i.e. the average of the individual regression lines).

From the literature, it is assumed that GEE analysis is robust against a wrong choice of correlation matrix (Liang & Zeger, 1986). To simplify the calculation process, exchangeable correlation structure was specified as a working correlation structure. In this correlation structure, the correlations between subsequent measurements are assumed to be the same, irrespective of the length of the time interval. The details of GEE is beyond the scope of this dissertation and will not be discussed. An extensive explanation can be found in other literatures (Kleinbaum & Klein, 2002; Hardin & Hilbe, 2003).

Another technique that can be used to analyze longitudinal data is random coefficient analysis or random-effect GLS analysis. This method was initially developed in the social sciences, more specifically for educational research (Twisk, 2003). Random coefficient analysis allows regression coefficients to differ between subjects. The advantage of this method is that the data output includes the log-likelihood and the coefficients of determination (r^2), indications of the adequacy (or fit) of the model. This log likelihood value can be used in the likelihood ratio test (Homer & Slideshow, 1989; Kleinbaum, 1994) and to evaluate goodness-of-fit for model selection (Pan, 2001).

For continuous outcome variables such as the correlation between subjective discomfort responses and physical environmental data, GEE analysis and random coefficient analysis provide almost identical results. For logistic regression analysis, the

two approaches may produce different results (see Figure 3.31). Twisk (2003) suggested that GEE analysis will probably provide the most valid results if the goal of a study is to estimate the relationship between a dichotomous outcome variable and several other predictor variables. Therefore, the parameter estimates will be drawn from GEE analysis.

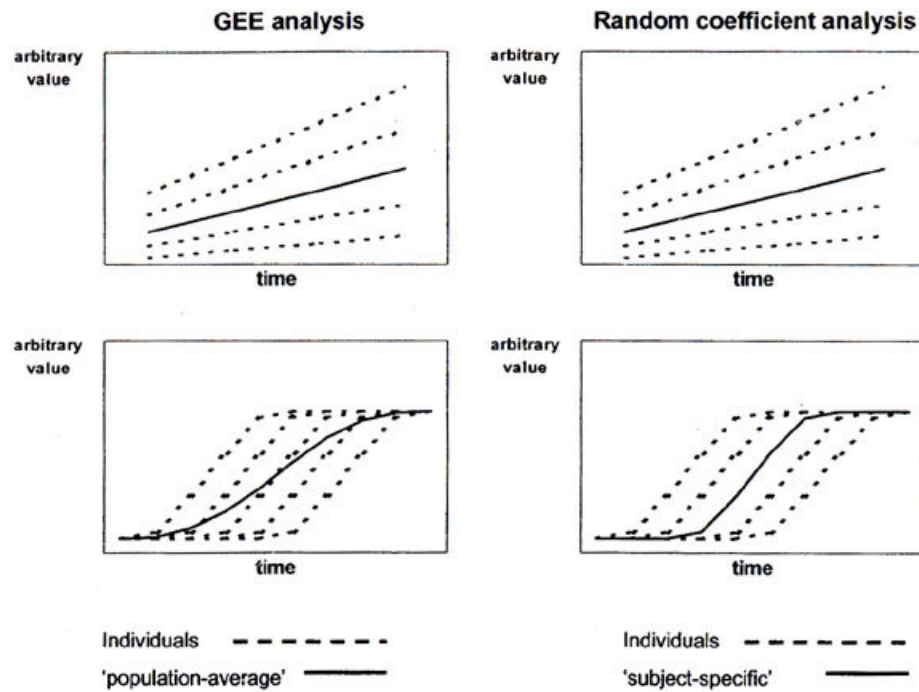

Figure 3.31 Illustration of the population average (GEE) and the subject specific approach (random coefficient analysis) for linear and logistic regression (from Twisk, 2003).

3.5.2.2 Typical GEE output

Figure 3.32 shows an example of a GEE analysis that was applied to investigate the relationship between the outcome variable *close* and four predictor variables *lg_{win}*, *T_{air}*, *lg_{sob}*, *bright*. The first line of the output indicates that a GEE analysis was performed. Number of observations, number of groups, and type of correlation structure are described. The names of variables are given in the first column.

For each of the predictor variables, the regression coefficient, the standard error of the coefficient and the corresponding p -value are given. The p -value is based on the Wald statistic, which is defined as the square of the ratio between the regression coefficient and its standard error (Twisk, 2003). This statistic follows a χ^2 distribution with n degree of freedom, where n equals the number of variable in the model.

Figure 3.32 Example of a GEE analysis output

```
GEE population-averaged model
Group variable:          subnum      Number of obs      =      73
Link:                   logit       Number of groups   =      23
Family:                 binomial    Obs per group: min =      1
Correlation:           exchangeable  avg               =      3.2
                                                max               =      4
                                                Wald chi2(4)      =      43.98
Scale parameter:       1            Prob > chi2        =      0.0000
                                (standard errors adjusted for clustering on subnum)
-----
```

		Semi-robust				
	close	Coef.	Std. Err.	z	P> z	[95% Conf. Interval]
	lgwin	2.153921	1.600877	1.35	0.178	-.9837415 5.291583
	tair	.273038	.3314798	0.82	0.410	-.3766506 .9227265
	lgsol	1.18583	.3525008	3.36	0.001	.4949406 1.876719
	bright	1.355132	.3383532	4.01	0.000	.6919723 2.018293
	_cons	-34.97767	26.12959	-1.34	0.181	-86.19072 16.23537

```
-----
Estimated within-subnum correlation matrix R:
      c1      c2      c3      c4
r1  1.0000
r2  0.0648  1.0000
r3  0.0648  0.0648  1.0000
r4  0.0648  0.0648  0.0648  1.0000
```

The odds ratio of each can be displayed by using the STATA function “eform” or taking the exponential of the regression coefficients on the second column for each variable. For example, the regression coefficient of variable $lgsol$ is 1.18 and the odds ratio is 3.27 ($e^{1.18}$). The odds ratio can be interpreted in two ways:

1. The cross-sectional interpretation is that a participant with a one-unit higher score for the predictor variable $lgsol$, compared to another participant, has 3.27 times higher odds of being in the highest group for the dichotomous outcome variable $close$.

2. The longitudinal interpretation is that an increase of one unit in predictor variable lg_{sol} within a participant over a certain time period is associated with 3.27 times higher odds of moving to the higher group of the dichotomous outcome variable *close*.

Finally, the within-subject covariate can be displayed by using the STATA function “xtcorr”.

3.5.2.3 Variable entry and model selection

In order to build regression models, this study used two techniques in which variables were added or removed in a series of steps. In the backward technique, the initial model included all of the independent variables. The parameters were estimated and any variables that did not exceed a pre-specified significance level ($p > 0.1$) were removed from the equation. The parameters were re-estimated until all remaining parameters exceeded the significance level ($p < 0.05$). The forward technique is the inverse of the backward technique. The initial model is small, and variables are added and tested for statistical significance.

For the linear and non-linear regression analysis, the models were ranked based on the coefficient of determination (r^2). For the logistic regression analysis, the models were preliminary evaluated with Akaike’s Information Criterion (AIC), calculated from the log likelihood values from standard logistic regression analysis. In choosing between models, the model with the smallest AIC criterion measure is preferred.

Additional model selection criteria included Nagelkerke’s r^2 , percentage of correct prediction, and area under the ROC curve.

CHAPTER 4

RESULTS

4.1 Introduction

This chapter presents results from the window blind usage survey and field study. The survey data were collected from 113 participants from 9 office buildings in Berkeley, California. The window blind usage pattern, measured by frequency of adjustment and level of occlusion, and window blind control reasons were examined by façade orientation and sky conditions.

The field study data were collected from 25 participants who occupied private offices in Berkeley, California between September 2004 and February 2005. Each participant was surveyed 1 to 4 times. A preliminary regression analysis showed that the correlation coefficients between subjective response and luminance data obtained from the Photolux system were higher than the coefficients obtained from the shielded luminance sensors on a free-standing pole. Therefore, this study focused on deriving regression and logistic models from Photolux luminance data only. The advantages and disadvantages of both methods will be described later.

The results from the window blind usage field study are divided into three sections. First, research participants and research sites are described. Second, the correlations between subjective response and physical environmental data are examined. Third, logistic models of window blind closing events are derived by using the standard logistic regression and Generalized Estimating Equation (GEE) methods.

4.2 Window blind usage survey

4.2.1 Descriptive information

Table 4.1 presents descriptive statistics of survey participants. Originally, a total of 188 building occupants completed the survey. However, only data from the occupants who sat within 15 feet from the window and had functional Venetian blinds were included in the analysis. Because survey participants had the flexibility to skip any questions at any time, skipped questions are reported as missing data.

The survey sample included 50 male and 63 female responses (44.2% and 55.8% respectively). Approximately 42% of the survey participants were under 40 years of age. The majority of survey participants faced a sidewall (44.2%), whereas one-fourth of the sample placed their computer against a window wall. A small number of participants stated that their seating orientation depended on the activities in which they were engaged (these were included in “Other”). The survey showed that approximately 10% of the participants occupied an office on the north façade, whereas 24% occupied an office on the south façade. Approximately 32% of the participants occupied an office on the east or west façade. Finally, almost 60% of the participants reported that they did not have effective external shading devices, and the majority of the participants (almost 70%) had an office with an air-conditioning system.

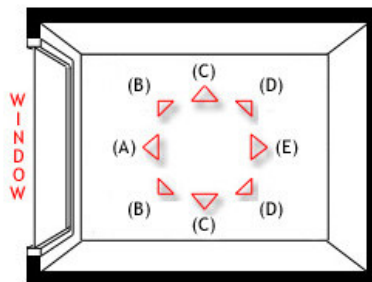

Figure 4.1 Plan view diagram of the workspace that was used in the window blind usage survey.

Table 4.1 Descriptive Statistics of Survey Participants (n = 113)

	Frequency	Percent
Gender		
Male	50	44.2
Female	63	55.8
Age		
Under 30	27	23.9
30-39	20	17.7
40-49	31	27.4
50-59	31	27.4
60 and above	3	2.7
Missing	1	0.9
Office Type		
Single private office	35	31.0
Shared private office	37	32.7
Open-plan office	41	36.3
Seating Orientation		
(A) Facing the window directly	10	8.8
(B) Facing window corner	19	16.8
(C) Facing sidewall	50	44.2
(D) Facing back wall corner	11	9.7
(E) Facing back wall	10	8.8
Other	13	11.5
Façade Orientation		
North	12	10.6
East	35	31.0
South	27	23.9
West	37	32.7
Missing	2	1.8
Glass Type		
Clear glass	78	69.0
Light-tinted glass	35	31.0
External Shading Device		
External Shading	48	42.5
No External Shading	65	57.5
Ventilation System		
Air-conditioned	76	67.3
Natural ventilation	37	32.7

Note. See Figure 4.1 for seating orientation description.

4.2.2 Why do people control their window blinds?

4.2.2.1 Window blind closing reasons

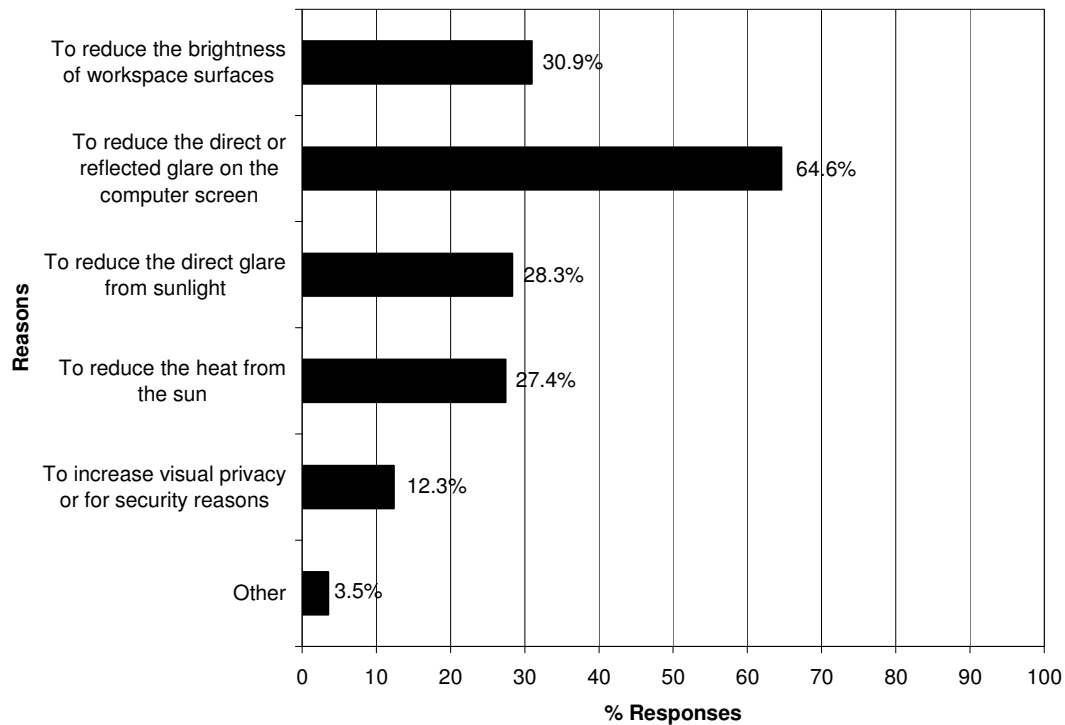

Figure 4.2 Window blind closing reasons.

Data from Figure 4.2 show that window blinds were primarily used to control brightness and glare in the workspace. The control of heat and glare from the sun and visual privacy were secondary reasons for closing window blinds. A small portion (3.5%) of survey participants gave other reasons for closing their blinds and were classified into the “Other” category in which they stated that the window blinds were used to control glare and heat.

Control of direct and reflected glare on the computer screen (hereafter referred to as the Visual Display Terminal [VDT]) was the most frequently mentioned reason for closing window blinds (65% of respondents). The sources of this glare included direct sunlight (88.9%), the window (48.5%), the wall or partition (27.3%), and the ceiling

(9.7%). Only 12.4% of the participants chose visual privacy as their closing reason. This finding confirms the hypothesis proposed in previous research that window blinds are used primarily to control direct sunlight and glare (Rubin et al., 1978, Rea, 1988; Lindsay & Littlefair, 1992; Pigg, 1996; Reinhart, 2001). This finding also partially agrees with Newsham's (1994) proposition that window blind control was based on thermal comfort.

The distributions of the approximate closing time for two reasons are shown in Figure 4.3. Because observations were not independent (participants were asked to choose all answers that applied), a Chi-square significance test could not be performed.

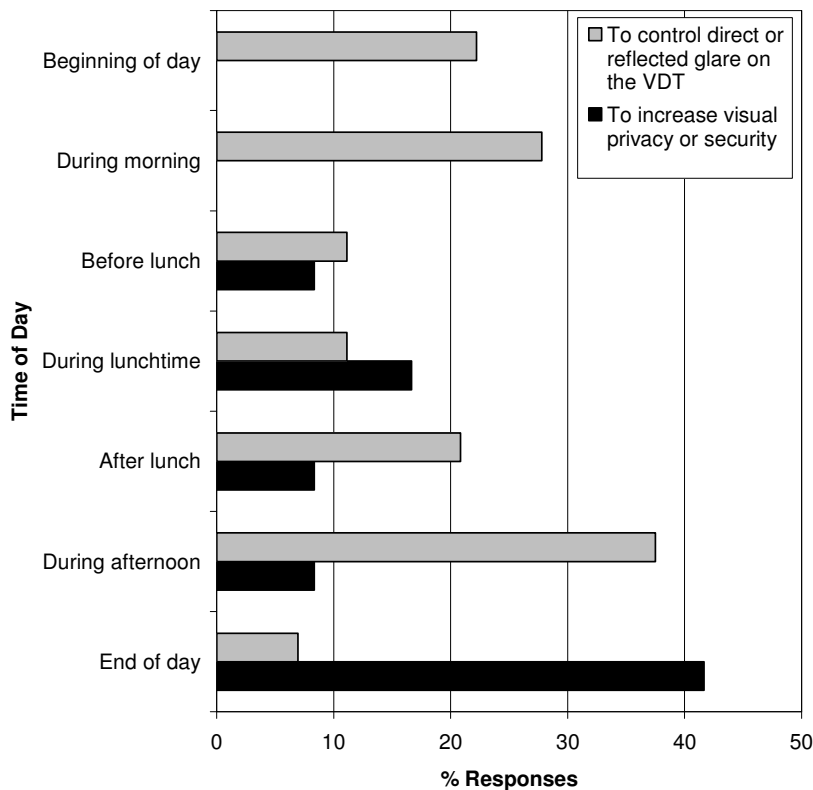

Figure 4.3 Comparison among approximate window blind closing times to control glare on the VDT and to increase visual privacy.

A preliminary visual analysis showed that building occupants primarily closed their window blinds to increase visual privacy or security at the end of the day,

irrespective of solar angle. However, the window blinds were closed throughout the day to control direct or reflected glare on the VDT.

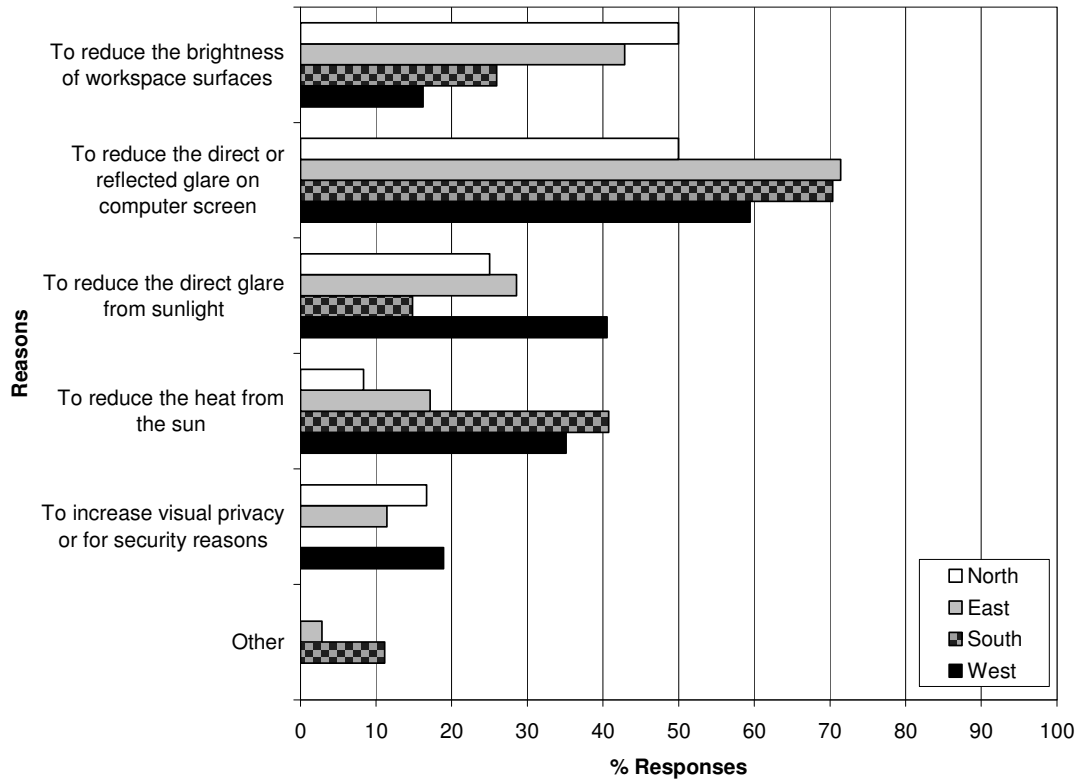

Figure 4.4 Window blind closing reasons by façade orientation.

Figure 4.4 describes window blind closing reasons by façade orientation. The examination of window blind usage by façade orientation suggests some interesting patterns:

1. Window blinds were primarily used to reduce glare on the VDT for all façade orientations.

2. Direct sunlight, which causes discomfort glare and overheating, was intercepted by participants in all façade orientations. For participants in the north façade

orientation, it could be implied that the participants close their window blinds in the summer time to avoid the low sun angle in early morning or late evening.

3. Participants on the north and east façade used window blinds to control the brightness of workspace surfaces, especially window brightness, more than those in the south and west façades.

4. Window blinds were used to control heat from the sun for participants on the south and west façades. Participants on the north and east façades used window blinds less often for this reason.

4.2.2.2 Window blinds opening reasons

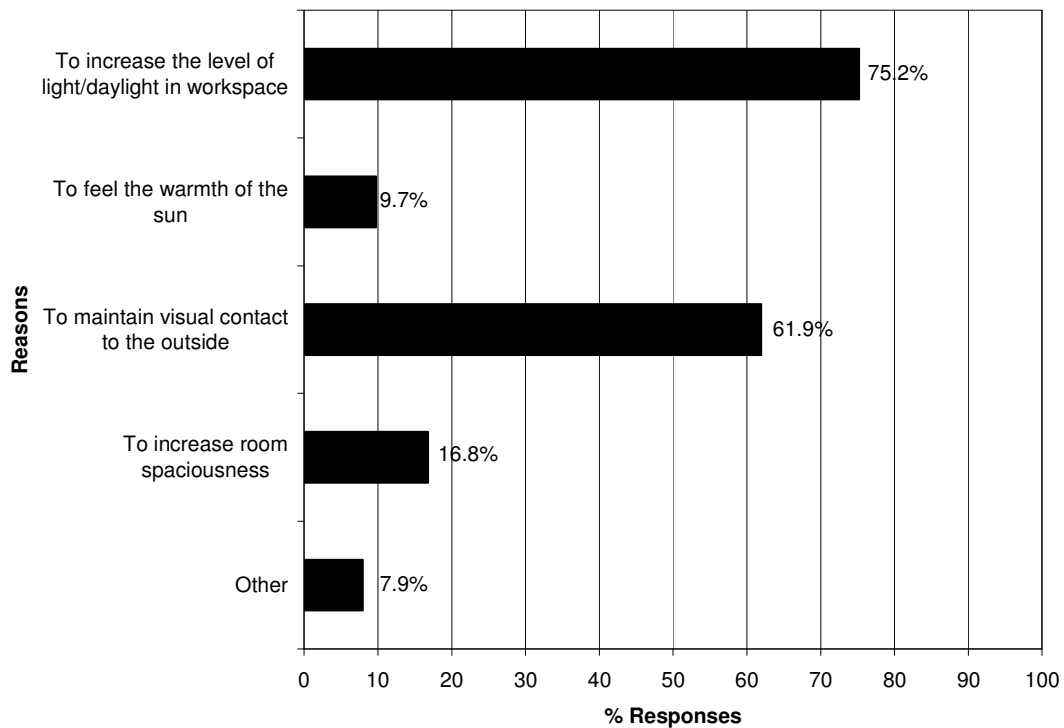

Figure 4.5 Window blind opening reasons.

Figure 4.5 displays descriptive statistics for window blind opening reasons. The results showed that participants opened their window blinds to increase the level of light

in their workspaces (75.2%) as well as to maintain visual contact to the outside (62.0%). To feel the warmth of the sun and to increase room spaciousness received many fewer votes (7.9 % and 16.8%, respectively) when compared with the first two reasons. The “Other” category included reasons such as keeping the window blinds open as a default state and providing natural light to inside workspaces.

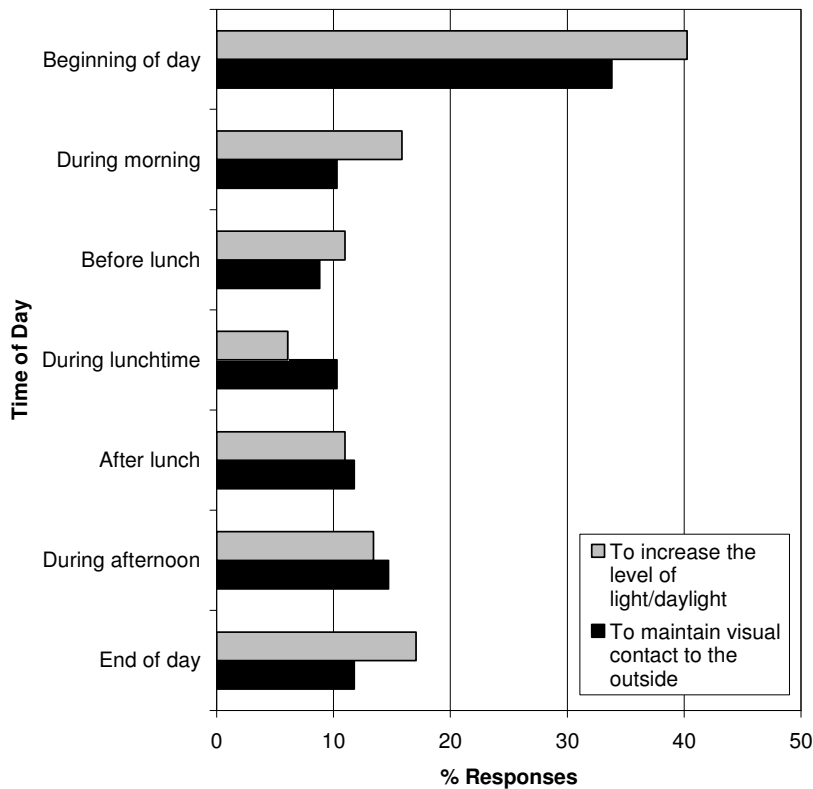

Figure 4.6 Approximate time of opening window blind to increase daylight level in a workspace and to maintain visual contact to the outside.

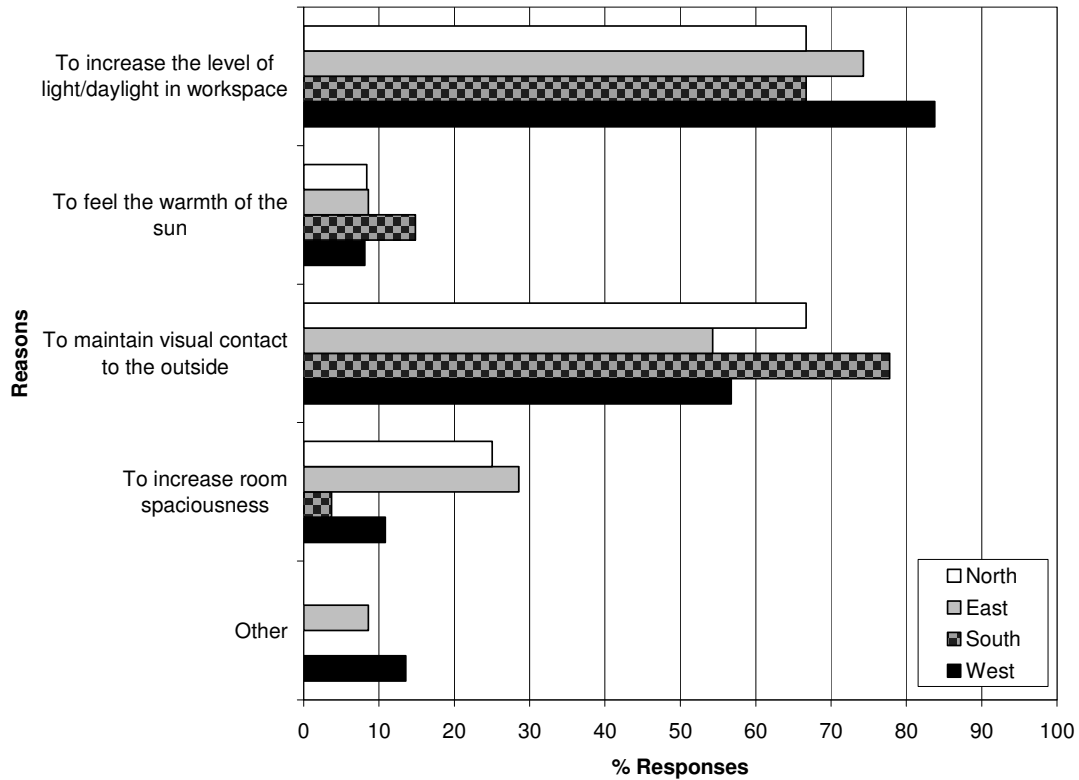

Figure 4.7 Window blind opening reasons by façade orientation.

The distribution of the approximate time of window blinds opening for two opening reasons are given in Figure 4.6. Figure 4.7 describes window blind opening reasons by façade orientation. The examination of window blind opening reasons suggests two interesting patterns:

1. The approximate window blind opening time between two opening reasons have similar distribution, i.e. for both reasons, window blinds are likely to be opened at the beginning of the day.
2. Window blinds were primarily opened to increase the level of light/daylight in workspace and to maintain visual contact to the outside for all façade orientations.

4.2.3 How do people control their window blinds?

4.2.3.1 Window blind positions by closing and opening reasons

In addition to the window blind closing and opening reasons, survey participants were asked to approximate the window blind position for each of the window blind adjustment reasons.

In order to compare the degree of occlusion for different closing and opening reasons, the average occlusion values for each reason were calculated by multiplying the pre-specified window blind closing position with the fractions of total responses. The average occlusion value is expressed as a number between 0 (fully opened) and 100 (fully closed). Distributions of the degree of occlusion and the average occlusion values (in parentheses) are shown in Figures 4.8 and 4.9.

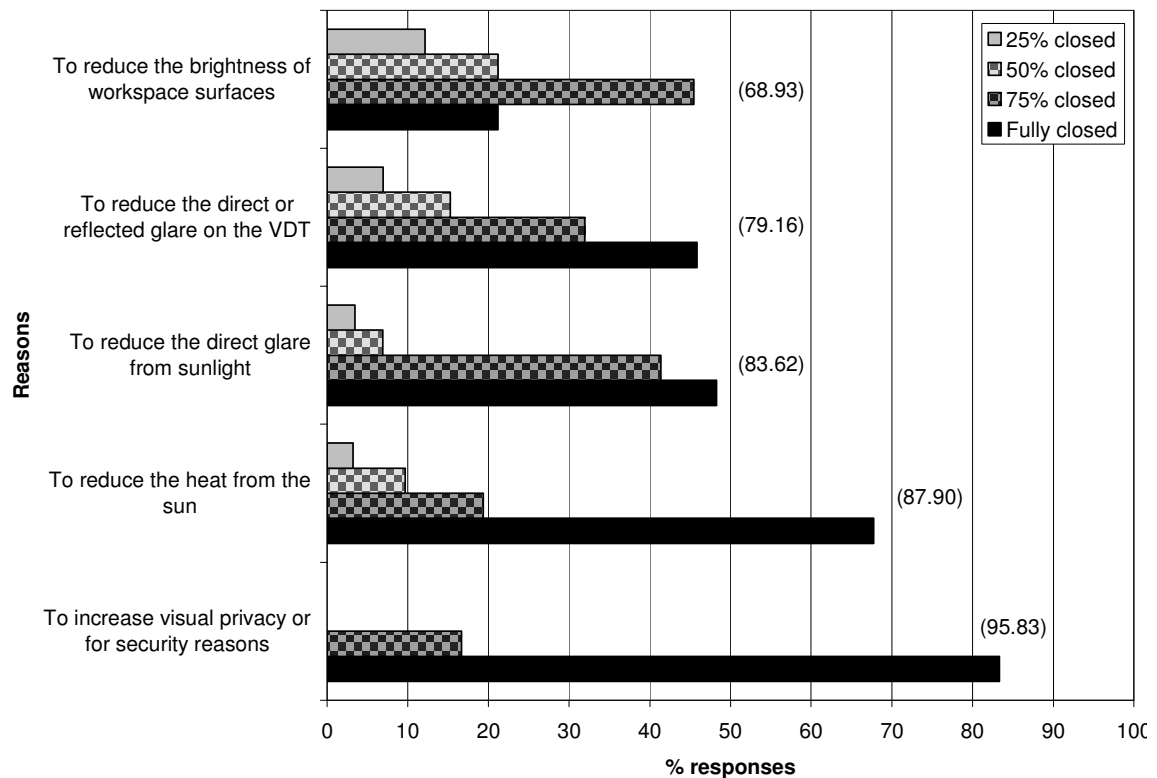

Figure 4.8 Window blind positions for each window blind closing reason.

The survey showed that approximately 83% of the window blinds were kept fully closed to increase visual privacy and for security reasons. A similar trend was found if the window blinds were closed to reduce heat from direct solar penetration. In this case, nearly 70% of the window blinds were kept fully closed. However, if the window blinds were closed as a means of reducing brightness and glare, only 21-45% of the window blinds were kept fully closed.

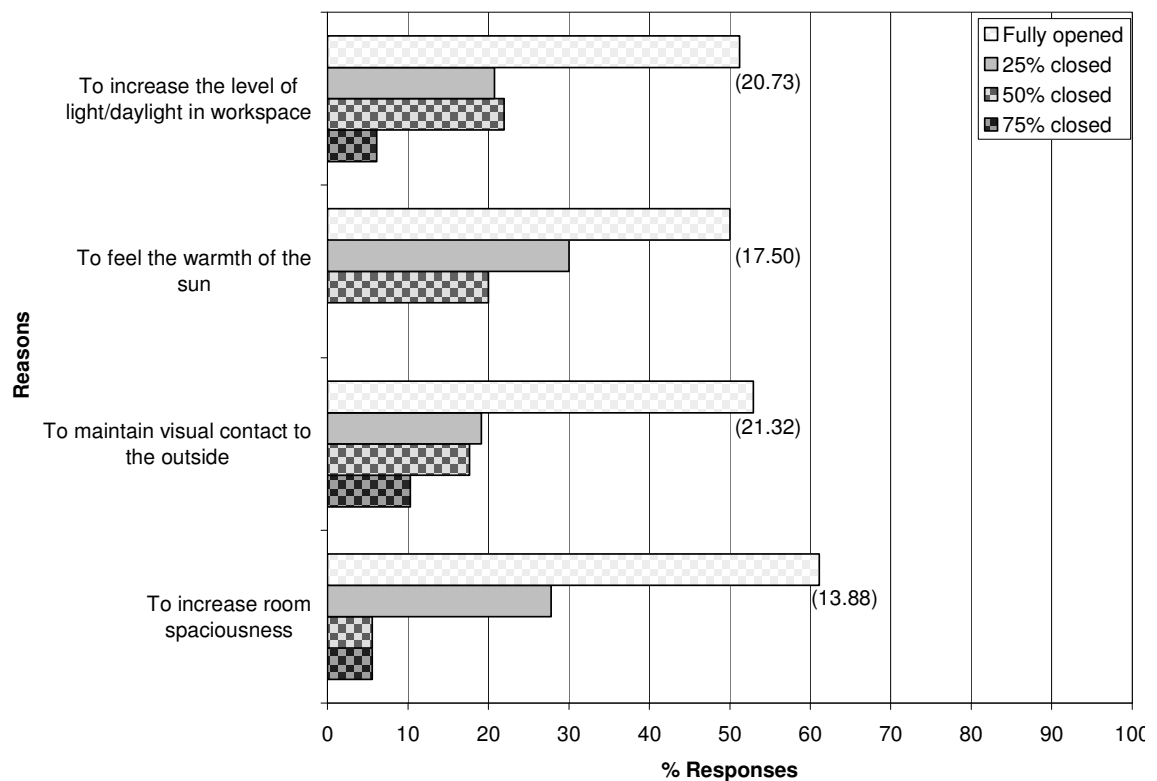

Figure 4.9 Window blind positions for each window blind opening reason.

Unlike closing reason positions, the opening reason position data showed that window blind positions across window blind opening reasons were quite similar. Approximately 50-60% of window blinds were set to fully open while about 20-30% of the window blinds were set to 25% closed.

4.2.3.2 Window blind positions on sunny and cloudy days

Figure 4.10 shows window blind positions on sunny versus cloudy days. The survey showed that window blinds were kept closed more often on a typical sunny day than on a cloudy day. The average occlusion index values for sunny days and cloudy days were 35.8 and 19.5, respectively. The sign test for two related samples was used to test statistical differences between the two sky conditions. The results showed that there were 46 survey participants who changed their window blind positions between sunny and cloudy conditions (45 negative differences and one positive difference) and 66 survey participants whose blind positions were the same between two sky conditions.

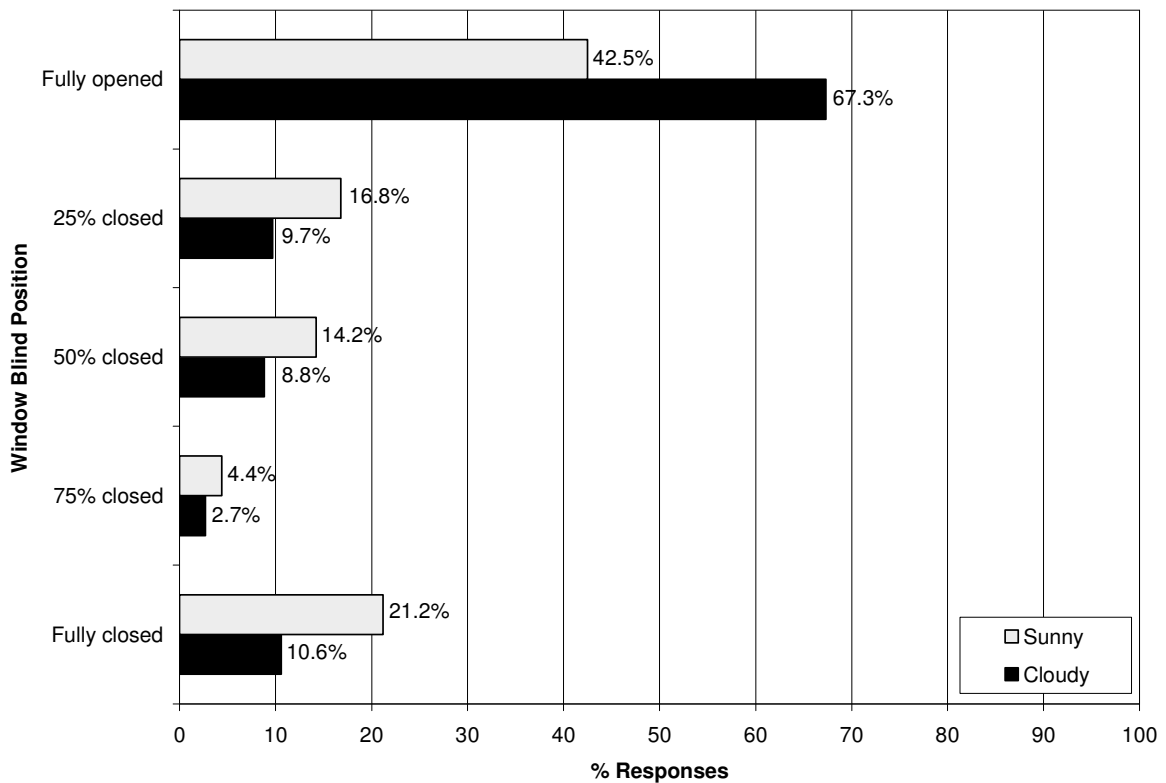

Figure 4.10 Window blind positions on sunny and cloudy days.

The sign test results show that the difference between a sunny and a cloudy day were statistically significant ($|z| = 6.3, p < .01$). This finding agrees with Rea's (1984) investigation of sky conditions and window blind occlusion. Therefore, it is concluded that sky conditions had an influence on the determination of window blind position by survey participants.

4.2.3.3 Frequency of slat angle adjustment on a sunny day

Table 4.11 shows the frequency of slat angle adjustment on a typical day. Window blind adjustment behaviors were categorized into three categories: Less than once per day, once per day, and more than one per day. The results showed that the majority of the sample (64.6%) adjusted their window blind slats less than once per day. Approximately 18% of the total sample adjusted their window blinds once per day, and another 18% adjusted them more than once per day.

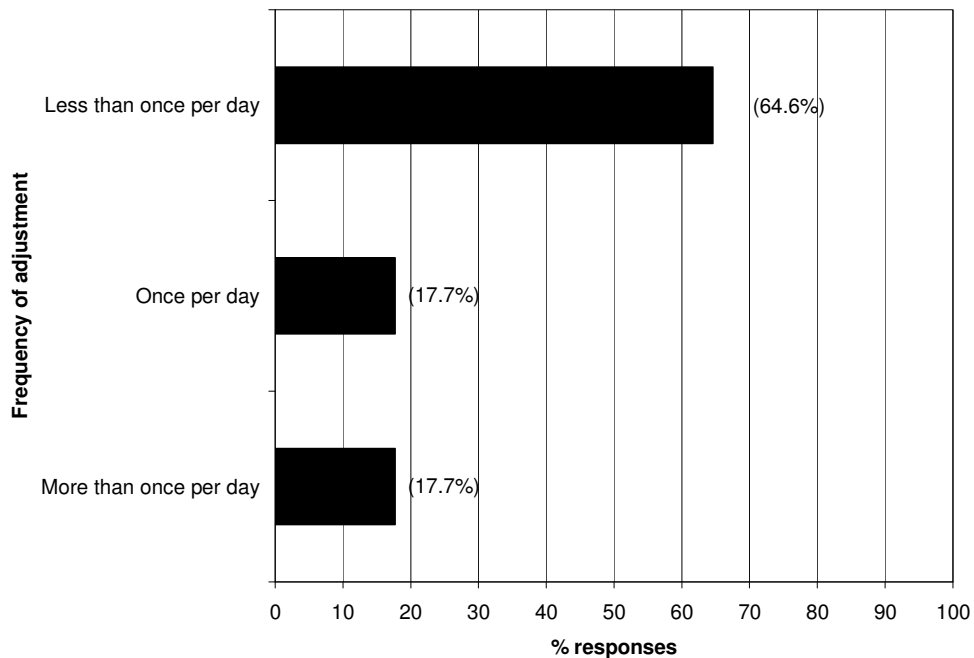

Figure 4.11 Frequency of window blind slat adjustment.

4.2.3.4 Frequency of adjustment on sunny and cloudy days

Figure 4.12 shows the frequency of blind height adjustment between sunny days and cloudy days. The results showed that approximately half of the survey participants adjusted their window blinds once or more on a sunny day. Window blind adjustment frequency decreased significantly on a cloudy day in which only 25% of the survey participants adjusted their window blinds once per day or more.

The sign test for two related samples was used to test for statistical differences between the two sky conditions. The results showed that there were 52 survey participants that report different rates of adjustment between sunny and cloudy sky conditions (48 negative differences and 4 positive differences). A total of 61 survey participants window blind rate of adjustment are the same between two sky conditions. The sign test showed that sky conditions influence the frequency of window blind adjustment ($|z| = 5.9, p < .01$). It is concluded that sky conditions had an influence on the frequency of window blind adjustments. In addition, the frequency of adjustment reported in this study agree with previous studies which found that building occupants rarely adjusted their window blinds during the course of a day, or from day to day (Rubins et al., 1978, Rea, 1988; Lindsey & Littlefair, 1992).

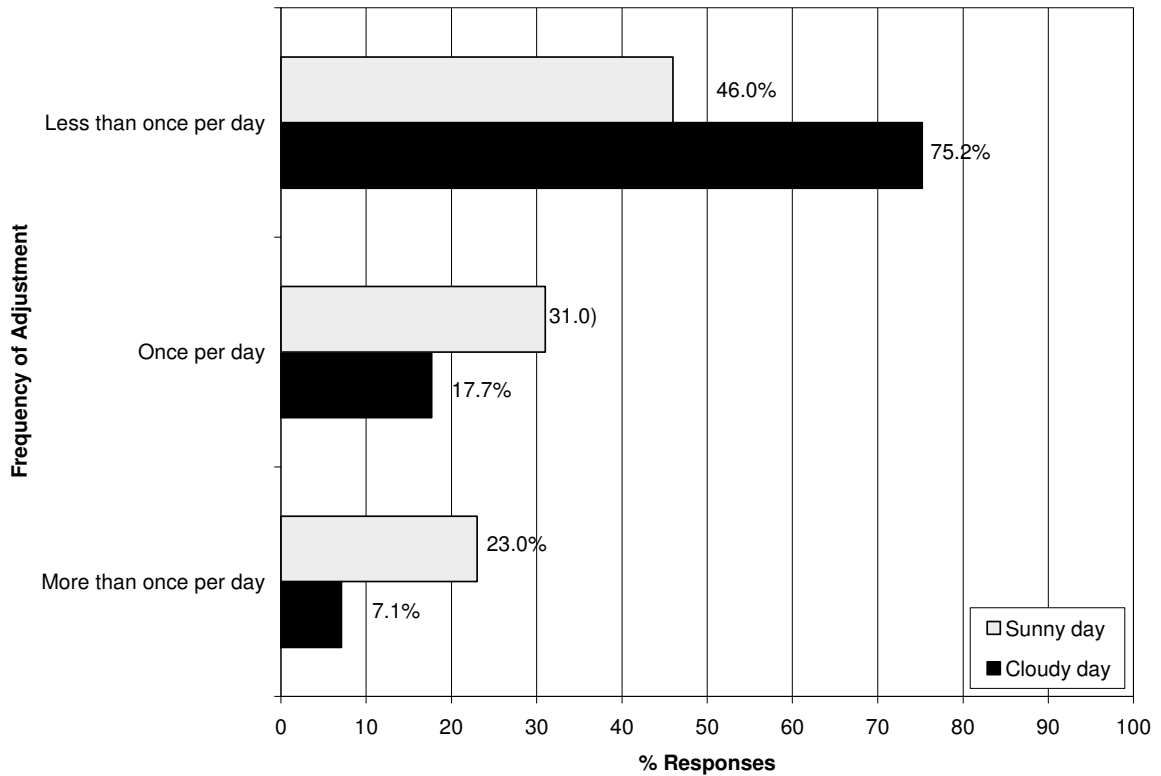

Figure 4.12 Comparison of window blind height adjustment frequency between sunny days and cloudy days.

4.2.3.4 Influences from other factors

One of the subsidiary hypotheses in this study was that contextual factors would influence window blind control behavior (frequency of adjustment and blind position). These contextual factors include glass type, external shading, and ventilation system. The results showed that only ventilation system differences influenced how survey participants set their window blind positions ($\chi^2 (4, N = 112) = 14.71, p < .05$). Comparison of average occlusion values for a typical day showed a 19-point difference between air-conditioned (AC) offices and naturally-ventilated (NV) offices (average occlusion values were 30 and 49, respectively).

Comparison of window blind positions for a typical day between AC offices and NV offices are shown in Figure 4.13. It was hypothesized that window blinds would be kept closed more often in NV offices than in AC offices because blinds are one of a few limited methods for NV offices to control temperature fluctuation, especially from direct sun.

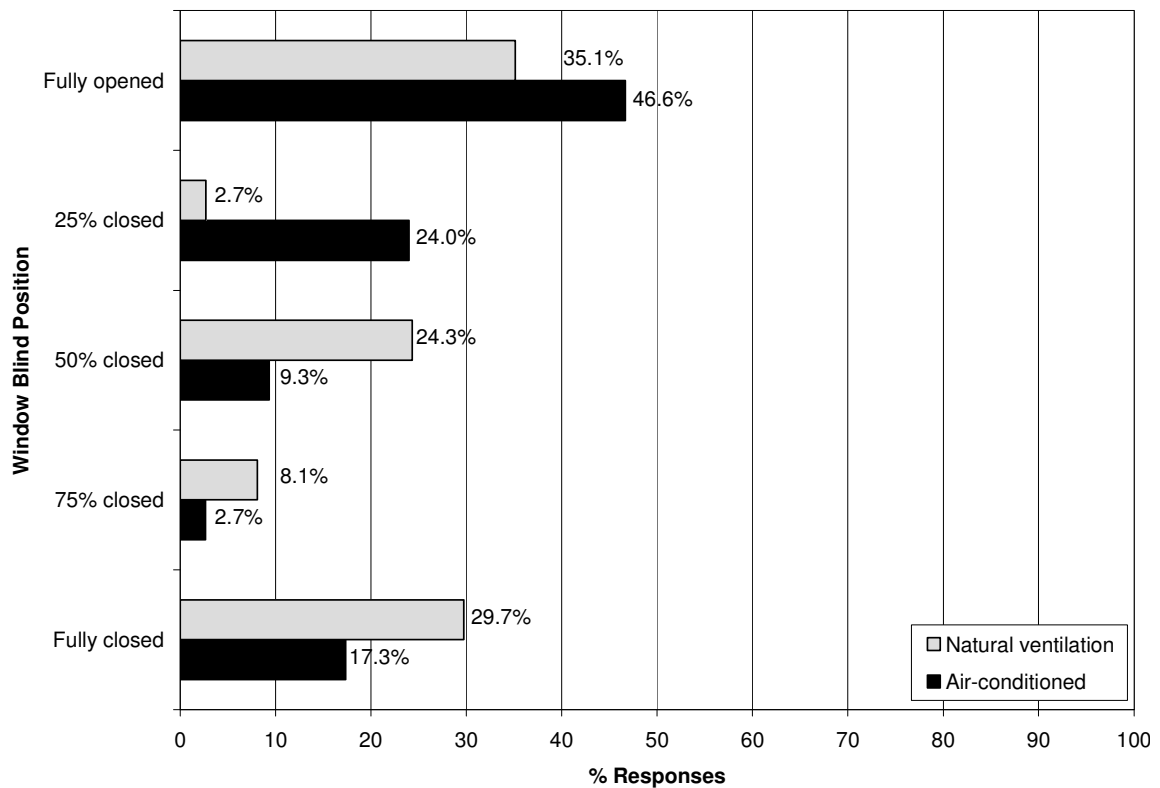

Figure 4.13 Comparison of window blind positions between naturally ventilated offices and air-conditioned offices.

4.2.4 Satisfaction with physical environment

Figures 4.14, 4.15, and 4.16 show descriptive statistics for occupants' satisfactions with overall window blind performance, lighting, and temperature conditions. The satisfaction vote ranged from -3 (least satisfied) to +3 (most satisfied). Overall, survey participants were satisfied with their window blinds ($M = 1.4$, $SD = 1.4$). Means for overall satisfaction with lighting and temperature were 1.1 ($SD = 1.6$) and -0.02 ($SD = 1.8$), respectively. These overall satisfaction values are similar to the values that were collected by the Center for Built Environment at UC Berkeley. In that study, overall satisfaction with lighting and temperature from 26,217 survey participants were 1.1 and -0.2 ($SDs \sim 1.6$) respectively (Zagreus, 2005).

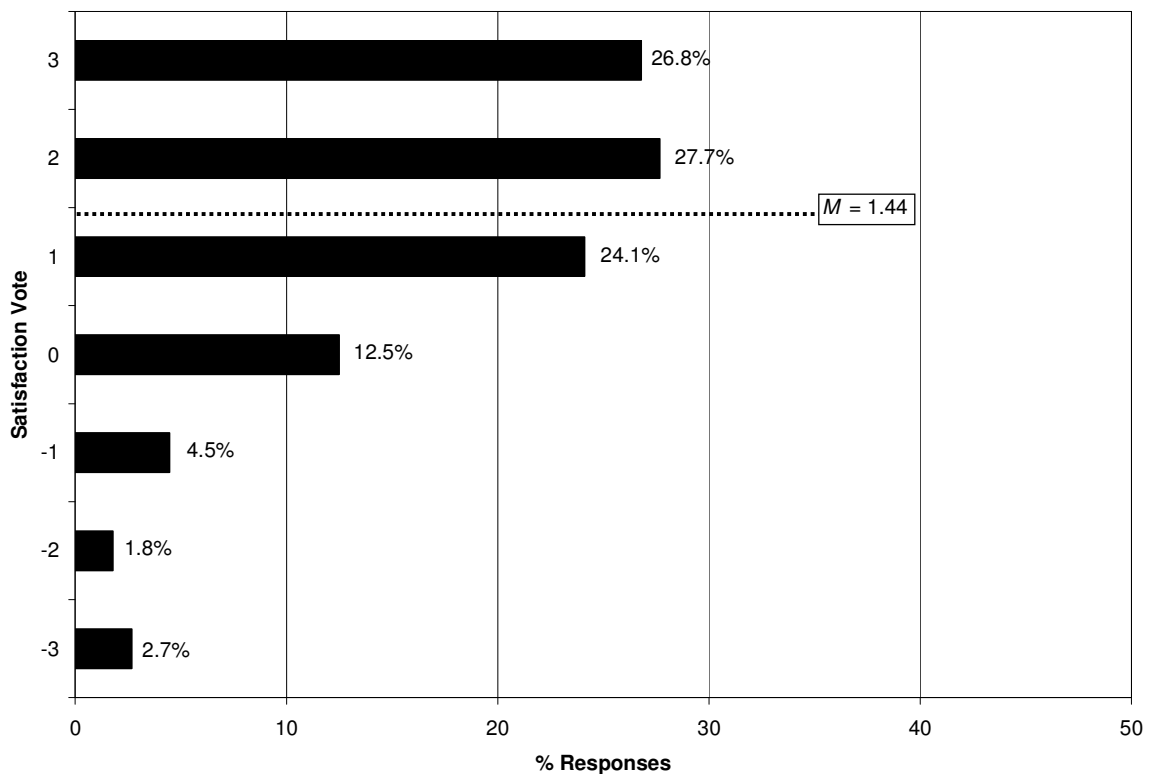

Figure 4.14 Distribution of satisfaction ratings of overall window blind performance.

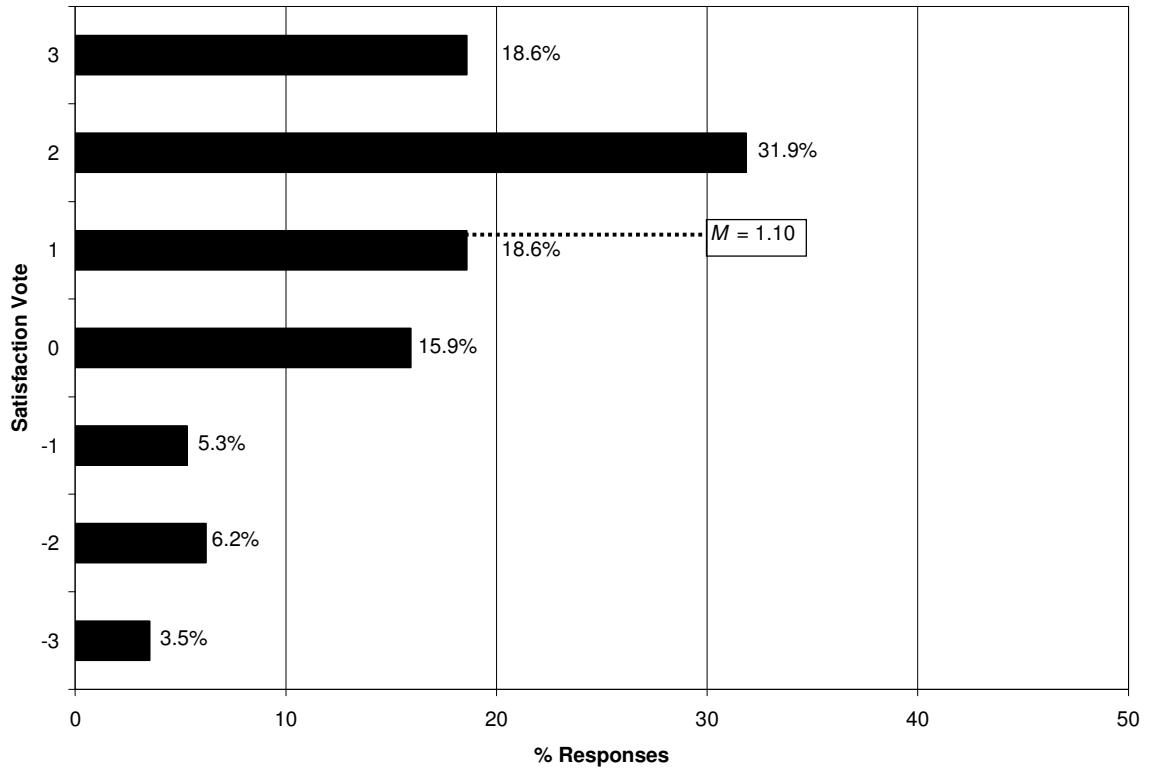

Figure 4.15 Distribution of satisfaction ratings of overall lighting.

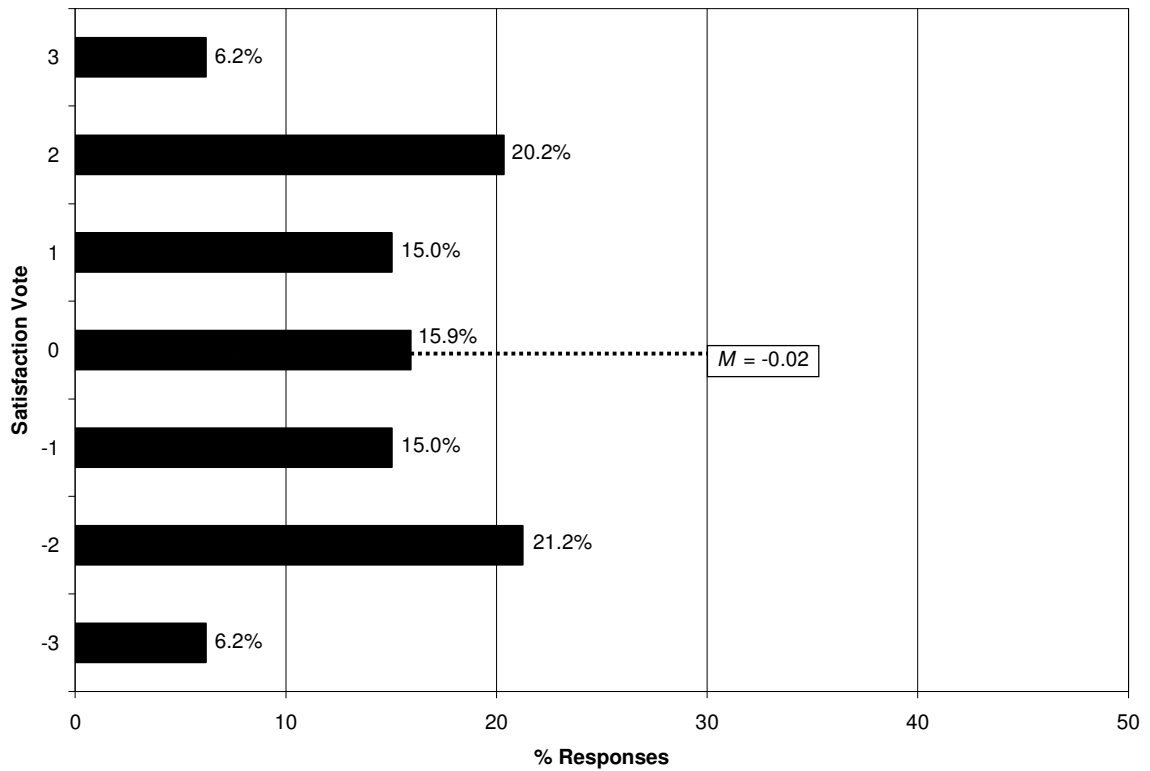

Figure 4.16 Distribution of satisfaction ratings of overall temperature.

4.2.5 Preference for the installation of an automated/intelligent window blind

Survey participants were asked if they preferred to have automated window blinds installed at their workspace. The survey showed that less than half of the participants (44.5%) preferred to have automated window blinds installed at their workspaces. Those participants who answered “yes” were also asked about the features that they would expect from an ideal automated/intelligent window blind system. The results indicated that glare protection was the most important feature. An ideal automated window blind should automatically reduce the level of glare while maintaining access to natural light and view. The second most important feature was related to usability features of the system, such as a user-override feature and a programmable feature. Lastly, an innovative control interface, such as voice-activated and remote control, should be incorporated into the ideal automated window blind system.

4.2.6 Summary of results from the window blind usage survey

The first part of this chapter examined the data from the window blind usage survey. The survey data confirmed window blind control characteristics from previous research and revealed a few characteristics that have not been covered in the previous literature:

1. Window blinds were closed for multiple reasons. The survey showed that window blinds were primarily closed to reduce glare on the VDT from sunlight and bright windows. Survey participants also specified other subsidiary reasons such as thermal comfort and visual privacy.

2. The majority of building occupants closed their window blinds to increase visual privacy or security at the end of the day. This control characteristic is driven by internal psychological factors rather than external physical factors (i.e. for the feeling of security rather than decreasing light and/or temperature).

3. Building occupants in offices with different façade orientations controlled window blinds for different closing reasons. For example, data in Figure 4.4 showed that building occupants on the north and east façades used window blinds primarily to reduce the brightness of workspace surfaces (walls, ceilings, and tables) but rarely closed window blinds to reduce heat from the sun. Based on this survey, temperature may not be a good window blind control predictor.

4. Building occupants opened their window blinds to increase the level of light/daylight in their workspaces and to maintain visual contact to the outside. The window blinds were likely to be opened at the beginning of the day. It was hypothesized that this control characteristic may be driven by internal psychological factors (sense of security) rather than external physical factors (light and heat).

5. The analysis of window blind positions by closing reasons showed that the degree of occlusion varied across different closing reasons. For example, when the window blinds were closed to increase visual privacy, the window blinds were kept at the fully closed position (occlusion index = 96; 83% at fully closed and 18% at 75% closed). On the contrary, when the window blinds were closed to reduce glare on the VDT, only 46% of the window blinds were kept at the fully closed position (occlusion index = 79.16; 31% at 75% closed, 15% at 50% closed, and 7% at 25% closed).

6. The survey results supported the hypothesis that sky conditions influence both the average occlusion and the frequency of adjustment of window blinds (Tables 4.2 and 4.3, respectively). These findings agree with the previous literature. Building occupants were likely to close their window blinds and to adjust their window blinds more often on sunny days than on cloudy days.

7. The majority of building occupants rarely adjusted their window blind positions and slat angles on a daily basis, i.e. only 23% of occupants adjust their window blinds more than once per day.

8. The level of satisfaction with lighting and temperature found in the current survey were comparable to those that were reported in a larger polling of office occupants (Zagreus, 2005). While the number of survey participants can not be directly compared between this current research and those from the database, it can be inferred that the results from this survey are representative of the opinion of a larger population.

9. Lastly, only 45% of the survey participants preferred to have an automated window blind installed at their workspace. A few key issues such as glare protection and system's usability were identified.

4.3 Window blind usage field study

The protocol of the field study was designed based on the window blind usage survey results. The survey data showed that typical building occupants usually kept their window blinds at fixed positions (mostly closed) and rarely adjusted them during the day. Because the driving factors for closing window blinds are not present when window blinds are closed, the field study protocol included opening the window blinds at occupants' workspaces to the fully opened position at the beginning of the test. After a brief period of adaptation to the raised blinds (5-10 minutes), research participants were asked if they wanted to close the window blinds, and if they did, they were asked for their reasons for closing the blinds.

The scheduling of this real-time assessment of lighting/temperature conditions session was approximately every two hours during normal work hours in which each participant was surveyed 1 to 4 times. This research design allowed a comparison between discomfort sensation, physical environmental condition and window blind closing preference, thus enabling the investigator to derive probability models of window blind control.

4.3.1 Descriptive information

Table 4.2 summarizes a few important characteristics of the field study participants. The field study data were collected from 11 male and 14 female participants (44% and 56%, respectively). The majority (68%) of the research participants were age 40 and above.

The field study data were collected in two buildings in Berkeley, California: the University of California Health Center (Tang) and the Lawrence Berkeley National Laboratory Administrative Building (LBNL) between September 2004 and February 2005.

Most of the participants at Tang sat facing a side wall, whereas most of the LBNL participants sat facing a window and wall corner. Only 20% of the total participants sat with their back against a window. In this study, the seating orientation variable was categorized into two major groups: facing window and facing wall.

Table 4.2 Summary of Field Study Participants' Descriptive Information

	Gender	Age	Building Number	Façade Orientation	Seating Orientation (<i>Divdt</i>)	Solid Angle (sr)	No. of Obs.	Bright Sensi (<i>L_{sen}</i>)	Temp. Sensi (<i>T_{sen}</i>)
1	M	<40	Tang	North	Side wall	2.61	4	5	6
2	F	≥40	LBNL	North	Window	0.93	4	6	6
3	F	<40	LBNL	North	Window	0.57	1	4	5
4	M	≥40	LBNL	North	Window	1.16	4	5	5
5	F	<40	LBNL	North	Window	1.02	2	4	6
6	F	≥40	LBNL	North	Side wall	1.00	4	2	5
7	F	<40	Tang	East	Side wall	1.06	4	7	4
8	M	≥40	LBNL	East	Window	0.52	3	5	2
9	F	≥40	LBNL	East	Side wall	0.92	1	4	4
10	M	≥40	LBNL	East	Side wall	0.9	4	6	4
11	F	≥40	LBNL	East	Window	0.97	4	5	4
12	F	≥40	Tang	South	Side wall	0.99	4	7	4
13	F	<40	Tang	South	Side wall	1.11	4	6	6
14	M	<40	Tang	South	Side wall	2.17	4	7	7
15	F	≥40	Tang	South	Side wall	0.49	4	4	4
16	F	≥40	LBNL	South	Window	1.20	4	7	5
17	M	<40	LBNL	South	Window	0.44	2	4	1
18	F	≥40	Tang	West	Side wall	1.39	4	7	4
19	M	<40	Tang	West	Side wall	0.76	1	2	5
20	F	≥40	Tang	West	Side wall	0.63	4	6	5
21	M	≥40	Tang	West	Side wall	1.93	3	3	2
22	F	≥40	LBNL	West	Side wall	0.76	4	5	2
23	M	≥40	LBNL	West	Window	1.25	3	3	3
24	M	≥40	LBNL	West	Side wall	0.70	3	6	2
25	M	≥40	LBNL	West	Side wall	0.73	4	2	2

In the current study, the size of the window is defined as the solid angle subtended at the eye of each participant which depends on the size of the window opening and the seating distance between the participant and the window. The average solid angle was 1.0 steradian (sr; $SD = 0.5$, $min = 0.4$ sr, $max = 2.6$ sr). The average self-reported brightness sensitivity (L_{sen}) and temperature sensitivity (T_{sen}) were 4.9 and 4.1, respectively (measured on a 7-point scale, where 1 = least sensitive and 7 = most sensitive). Approximately 64% of the total participants were surveyed 4 times and 12% of the total participants were surveyed only once.

Table 4.3 Window Blind Position by Façade Orientation

Façade orientation	Blind position preferences		Total
	Want no change	Want to close	
North	11	8	19
East	2	14	16
South	2	20	22
West	8	18	26
Total	23	60	83

Table 4.3 summarizes window blind position preferences by façade orientation. In the current study, workspaces were surveyed 83 times. After the window blinds were raised, research participants indicated that they would like to close the window blinds 60 times (72%). There were 23 times (28%) that research participants indicated that they prefer not to close the window blinds. The data showed that building occupants on the north façade are more likely to leave their blinds open than occupants on other façade orientations.

A Fisher Exact Test was used to determine the significance of difference closing preferences between north façade and other façade orientations. Table 4.4 showed that

distribution of closing preferences for North façade orientation was significantly different from the east and south façade orientation orientations (Fisher Exact $p < .05$) but not from the west façade orientation ($p > .05$). The distribution of closing preferences for east, south, and west façade orientation were found to be similar ($p > .05$).

Table 4.4 Summary of Chi-Square and Fisher’s Exact Test for Window Blind Position Preferences

Model	Fisher exact (p)	n
North x East	0.01	35
North x South	0.00	41
North x West	0.07	45
East x South	1.00	38
East x West	0.27	42
South x West	0.08	48

4.3.2 Correlation between subjective responses and physical data

The investigation of the physical environmental predictors that best represents participants’ visual and thermal comfort sensation is the first task in the analysis of the field study. This task was accomplished by selecting variables that were moderately correlated with participants’ subjective responses and then entering those variables into a regression analysis.

Table 4.5 presents descriptive statistics for each independent variable. The distributions of all of these variables were strongly skewed to the right, except for air temperature (T_{air}), Mean Radiant Temperature (MRT), and relative humidity (RH). Therefore, a log-transformation was applied to each skewed variable (see Figures 4.17 and 4.18 for an example). Intercorrelations among visual and thermal comfort variables are shown in Tables 4.6 and 4.7, respectively.

Table 4.5 Descriptive Statistics for Independent Variables

Variables	Obs.	Unit	Mean	SD	Minimum	Maximum
L_{glo1}	83	cd/m ²	577.9	558.1	125.9	2627.9
L_{win}	83	cd/m ²	2002.5	1235.1	269.7	5761.5
L_{mxwin}	83	cd/m ²	11099.4	7514.4	1066.6	34057.8
L_{glo2}	83	cd/m ²	415.2	412.6	105.2	2379.0
L_{mx60}	83	cd/m ²	410.2	1021.3	56.2	8065.2
L_{mx120}	83	cd/m ²	7810.2	7602.8	200.0	29014.2
E_{wrk}	60	lux	1595.6	2467.7	128.9	17764.5
SOL	73	W/m ²	74.8	86.3	3.4	356.8
T_{air}	75	°F	73.6	2.5	68.0	80.1
MRT	75	°F	73.7	3.3	64.2	82.9
RH	75	%	35.8	6.2	25.3	53.1
L_{glo3}	63	cd/m ²	462.3	526.9	46.09	2920.35
L_{win3}	63	cd/m ²	1538.1	1605.3	105.37	8746.70

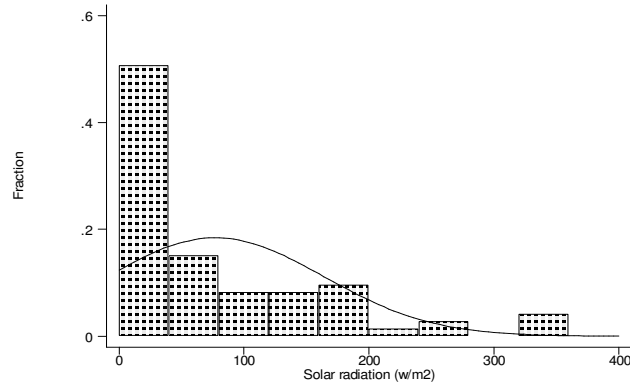

Figure 4.17 Distribution of vertical solar radiation before a log-transformation. Normal distribution curves are overlaid on the chart.

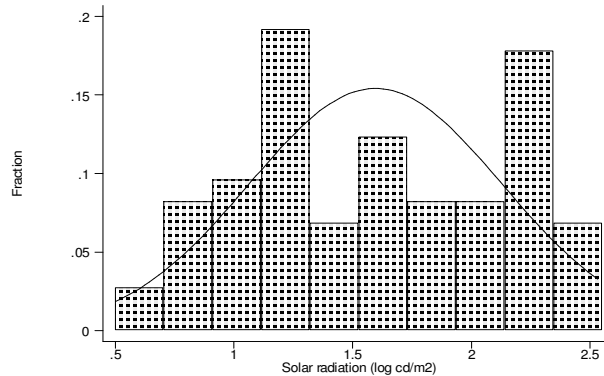

Figure 4.18 Distribution of vertical solar radiation after a log-transformation. Normal distribution curves are overlaid on the chart.

Table 4.6 Intercorrelations (r) among Visual Comfort Variables (n = 60)

	L_{mxwin}	L_{win}	SOL	L_{glo1}	L_{glo2}	L_{mx60}	L_{mx120}	L_{glo3}	L_{win3}	E_{work}
L_{mxwin}	1.00									
L_{win}	0.83	1.00								
SOL	0.68	0.77	1.00							
L_{glo1}	0.82	0.80	0.66	1.00						
L_{glo2}	0.72	0.72	0.60	0.92	1.00					
L_{mx60}	0.50	0.56	0.62	0.51	0.69	1.00				
L_{mx120}	0.58	0.43	0.44	0.64	0.73	0.57	1.00			
L_{glo3}	0.43	0.53	0.21	0.37	0.28	0.20	0.16	1.00		
L_{win3}	0.44	0.55	0.32	0.27	0.13	0.08	0.05	0.82	1.00	
E_{work}	0.16	0.15	0.19	0.15	0.02	0.08	0.04	0.46	0.35	1.00

Table 4.7 Intercorrelations (r) among Thermal Comfort Variables (n = 73)

	T_{air}	SOL	MRT
T_{air}	1		
SOL	0.49	1	
MRT	0.89	0.32	1

These correlations highlight some important characteristics. First, the luminance data obtained from the Photolux systems (L_{mxwin} , L_{win} , L_{glo1} , L_{glo2} , L_{mx60} and L_{mx120}) are strongly correlated with one another. Second, the correlations between luminance data obtained from the Photolux systems and from the shielded sensors (L_{win3} , L_{glo3}) were low to moderate in size. Third, workplane illuminance (E_{work}) had the weakest correlations with other visual comfort variables. Fourth, solar radiation (SOL) was moderately to strongly correlate with both visual and thermal comfort variables.

Intercorrelation analysis showed that luminance variables collected in this study were measuring similar constructs and the information in most of the variables is at least partially redundant with that in other variables. In order to overcome the colinearity problem, a stepwise regression technique (backward elimination and forward selection) was implemented. In addition, a few variables were removed from further regression analysis.

4.3.2.1 Visual comfort

One of the subsidiary hypotheses tested in the current research was that the sensation of discomfort would increase as the magnitude of each physical environmental predictor increased. The preliminary visual comfort predictors consisted of average window luminance (L_{win}), background luminance (L_{glo1} , L_{glo2}), maximum window luminance (L_{mxwin}), Daylight Glare Indices (DGI_h , DGI_f), average luminance within a 60° visual cone (L_{mx60}), and maximum luminance within a 120° visual cone (L_{mx120}). In addition, direct sun penetration ($Disun$), seating direction ($Divdt$), sky condition (SKY), and self-reported sensitivity to brightness (L_{sen}) were treated as confounding variables. In order to test the above hypothesis, the data were analyzed by using longitudinal regression analysis techniques: random-effects Generalized Least Squares (GLS) regression and Generalized Estimating Equations (GEE). Regression coefficients and p -values for each independent variable are presented in Table 4.8.

Table 4.8 Summary of Regression Analysis for Variables Predicting Discomfort Glare Sensation

Model No.	Variable	Standard Regression		Random-Effects GLS		GEE		r^2
		α	β	α	β	α	β	
V1	L_{mxwin}	0.19	0.31	0.15	0.34	0.14	0.34	0.29**
V2	L_{win}	0.25	0.35	0.12	0.45	0.12	0.46	0.27**
V3	SOL	1.54	0.19	1.48	0.19	1.49	0.19	0.23**
V4	L_{glo1}	0.57	0.28	0.29	0.39	0.29	0.39	0.23**
V5	L_{glo2}	0.65	0.28	0.28	0.42	0.28	0.42	0.20**
V6	L_{mx60}	1.26	0.16	1.09	0.18	1.11	0.18	0.13**
V7	L_{mx120}	1.53	0.09	0.80	0.16	0.83	0.16	0.07**
V8	L_{glo3}	1.64	0.11	1.22	0.16	1.21	0.16	0.04**
V9	L_{win3}	1.74	0.08	1.29	0.12	1.28	0.12	0.03*
V10	E_{work}^\dagger	3.48	-0.02	2.01	0.06	1.99	0.06	0.00†
DGI								
	DGI_f	-1.25	0.18	-2.24	0.22	-2.39	0.23	0.17**
	DGI_h	0.05	0.15	-0.51	0.10	-0.57	0.17	0.11**

† $p > .05$, * $p < .05$, ** $p < .01$

The data showed that the regression coefficients obtained from each longitudinal method (random-effects GLS and GEE) are comparable. The regression coefficients obtained from a standard regression method, however, could produce a significantly different comfort sensation estimates when compared to the coefficients obtained from longitudinal regression methods (see Figures 4.20 and 4.22). For example, the estimate window luminance levels that would produce intolerable glare sensation from the standard and longitudinal regression method are 5,900 and 4,700 cd/m^2 , respectively. The different was due to the within-subject covariates.

The results support the hypothesis that the sensation of discomfort increases as the magnitude of each physical environmental predictor increases. The magnitude of discomfort sensation (Ψ) was found to increase as a power function of the magnitudes of various stimuli (Φ).

Figures 4.19 to 4.22 show scatterplots of glare sensation as a function of maximum window luminance (L_{mxwin}), average window luminance (L_{win}), vertical solar radiation (SOL) and background luminance (L_{glol}), respectively. The regression curves from the standard regression and random-effects GLS regression methods are shown for comparison. Figures 4.23 to 4.24 show scatter plots of glare sensation as a function of DGI. The regression line from the random-effects GLS method is shown for comparison with the original glare criteria.

Subjective discomfort sensation could be estimated from these stimulus variables (except the *DGIs*) by applying the regression coefficient (β) and constant (α) from Table 4.8 to the following magnitude estimation equation:

$$\Psi = \alpha\Phi^\beta \quad (4.1)$$

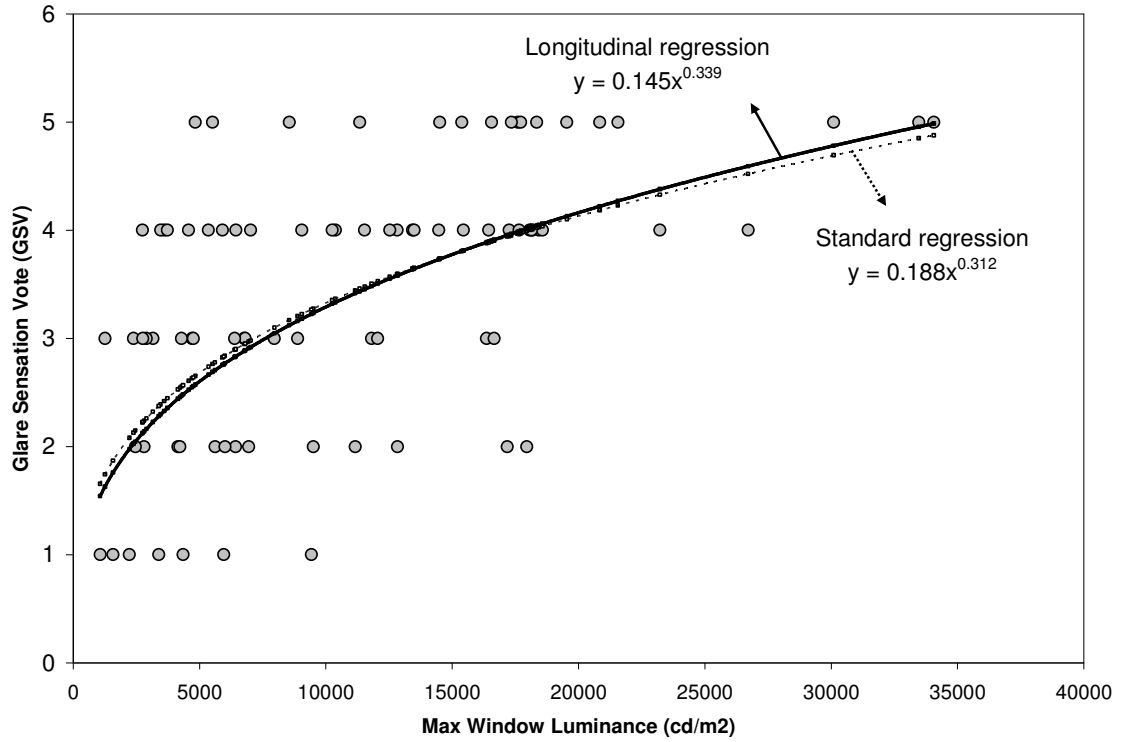

Figure 4.19 Scatterplot of glare sensation as a function of maximum window luminance (L_{mxwin}).

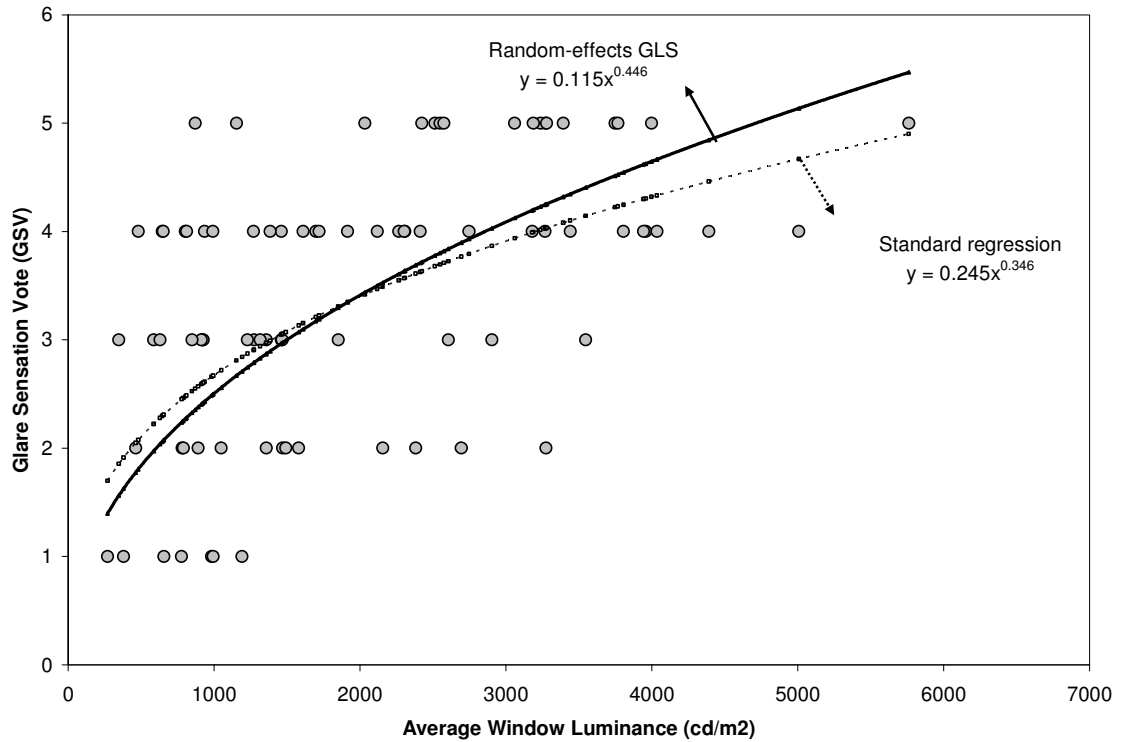

Figure 4.20 Scatterplot of glare sensation as a function of average window luminance (L_{win}).

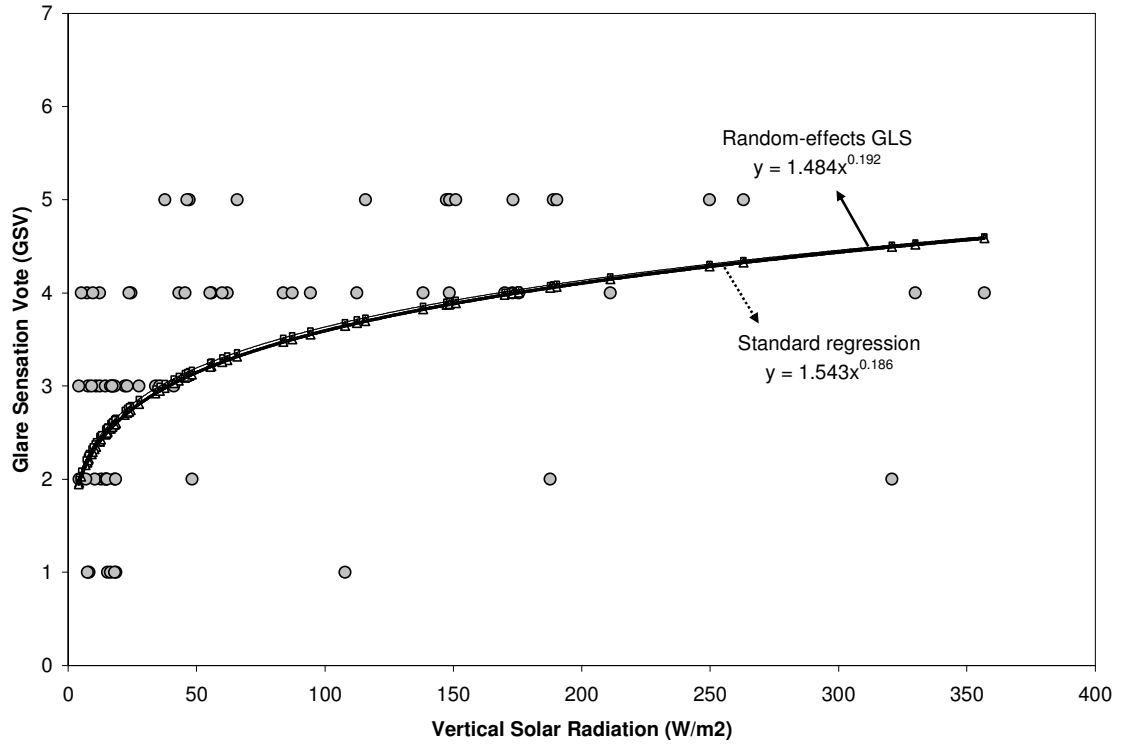

Figure 4.21 Scatterplot of glare sensation as a function of vertical solar radiation (SOL).

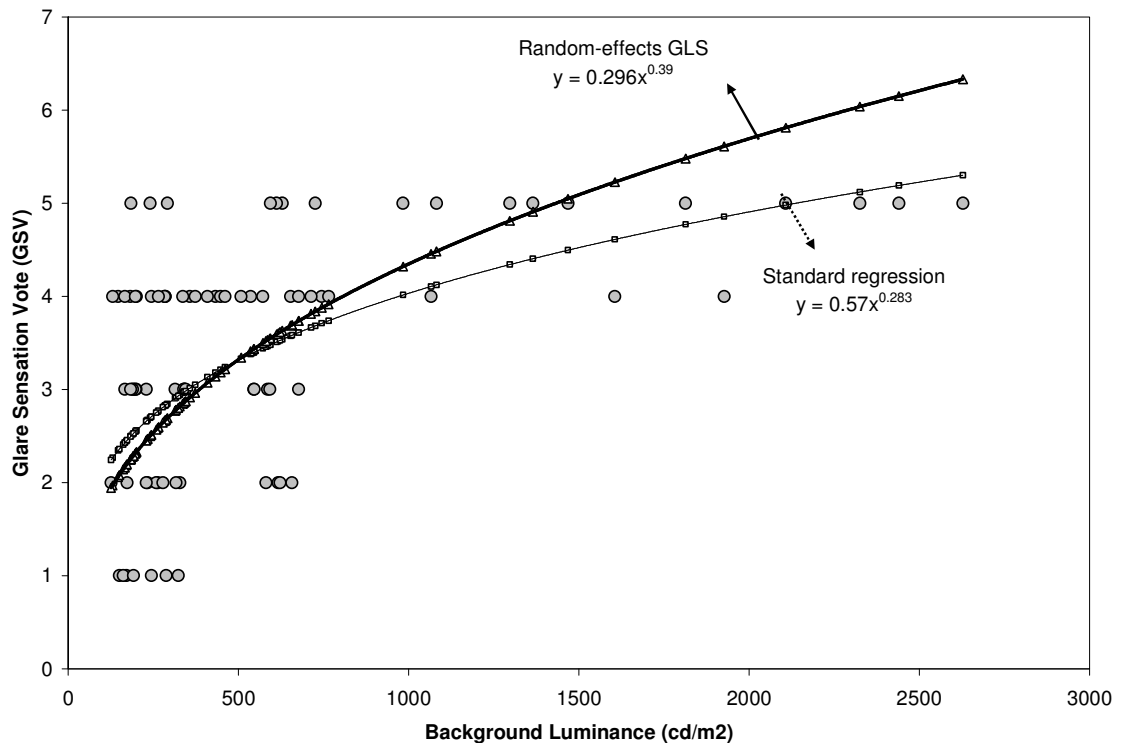

Figure 4.22 Scatterplot of glare sensation as a function of background luminance (L_{glo1}).

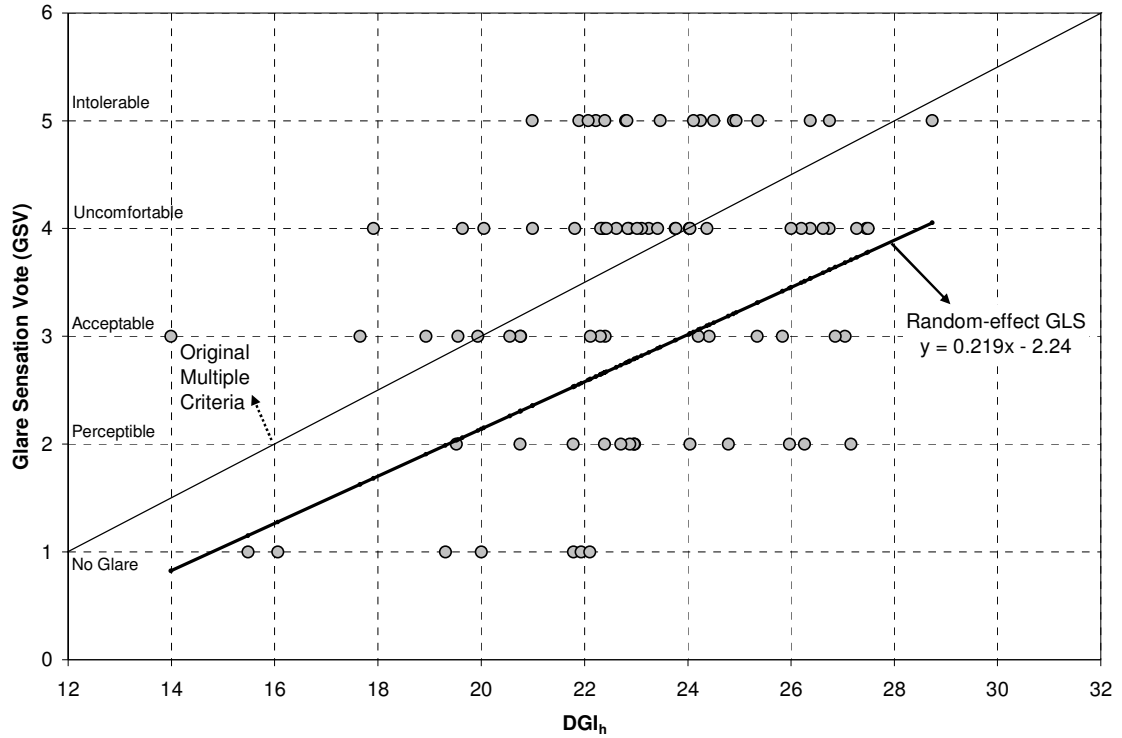

Figure 4.23 Scatterplot of glare sensation as a function of Daylight Glare Index (DGI_h; Hopkinson-Chauvel's formula).

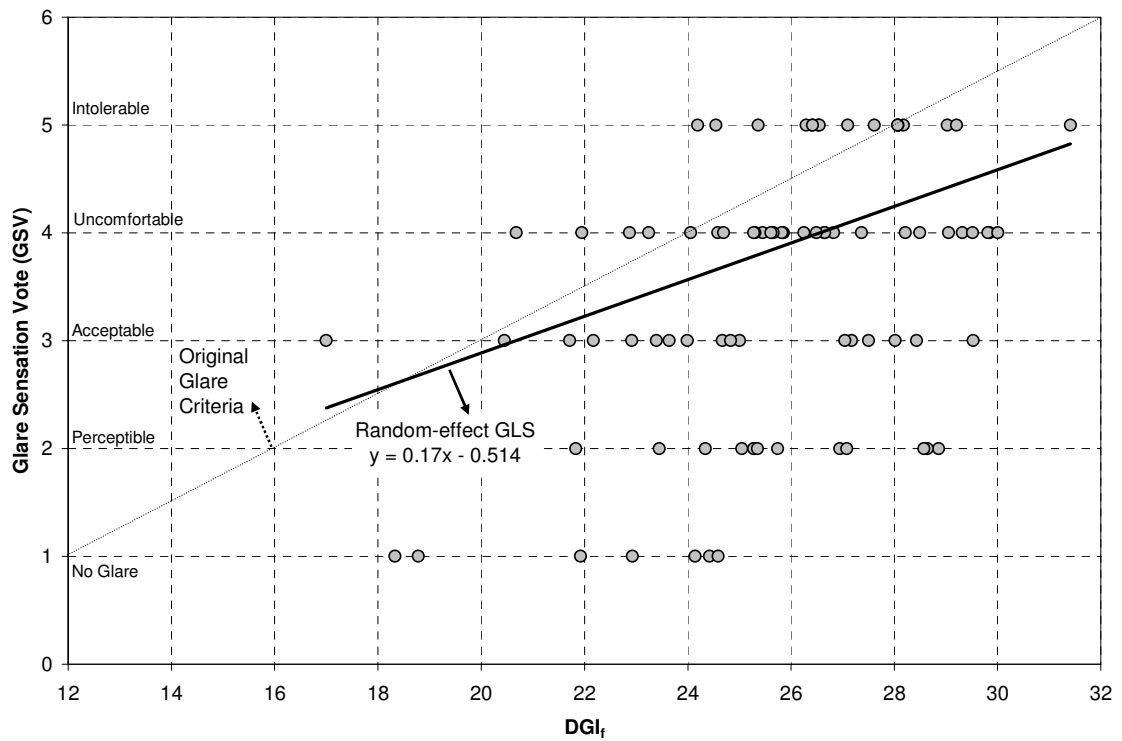

Figure 4.24 Scatterplot of glare sensation as a function of modified Daylight Glare Index (DGI_f; Fisekis et al., 2003).

For the Daylight Glare Index (DGI), the results show that the magnitude of discomfort sensation has a linear relationship with each variable and can be estimated by applying the regression coefficient (β) and constant (α) from Table 4.8 to the following equation:

$$\Psi = \alpha + \beta (\text{DGI}) \quad (4.2)$$

Data from Table 4.8 show that maximum window luminance (L_{mxwin}) and window luminance (L_{win}) have the highest correlations with discomfort ($r = 0.53$ and $r = 0.52$, respectively). Vertical solar radiation at the window (SOL) and background luminance from two viewpoints (L_{glo1} and L_{glo2}), were found to had somewhat lower correlation with subjective responses ($r = 0.48$, $r = 0.47$, and $r = 0.40$, respectively). The average luminance within 60° of the visual cone (L_{mx60}) and the maximum luminance within 120° of the visual cone (L_{mx120}) were weakly correlated with subjective responses ($r = 0.36$ and $r = 0.26$, respectively). Average window luminance (L_{win3}) and background luminance (L_{glo3}) measured by Li-Cor sensors were very weakly correlated with discomfort ($r = 0.20$ and $r = 0.17$, respectively). Finally, workplane illuminance (E_{wrk}) was not significantly correlated with discomfort ($r = 0.00$). The exponential value (β) ranged from 0.16 to 0.46 for all luminance related variables. These values are comparable to those reported from previous lighting research (Bodmann & La Toison, 1994; Osterhaus, 1998; Osterhaus & Bailey, 1992; Stevens, 1975).

Table 4.8 also presents the regression coefficients for Daylight Glare Indices from two formulae: the Hopkinson-Chauvel's formula (DGI_h) and the modified formula (DGI_f ; Fisekis et al., 2003). The results showed that the modified formula (DGI_f) is slightly better at explaining subjective glare sensation than the original Hopkinson-Chauvel's formula (DGI_h). Both DGIs have a weak but significant relationship with subjective discomfort (DGI_f : $r = 0.41$; DGI_h : $r = 0.33$).

As shown in Table 4.8, DGI explained only 11-17% of the variance in subjective glare sensation whereas the lower-order components of the DGI (average window luminance and background luminance) explained 20-30% of the variance in subjective glare sensation. This finding supports the proposition from previous research that glare sensation from a large source (window) could be predicted from a simpler predictor (Aries, 2003; Osterhaus, 1998; Osterhaus & Bailey, 1992).

The data were also analyzed with multiple regression techniques. A few multivariate models were derived. Table 4.9 shows the regression coefficients from three multivariate models from the random-effects GLS regression method. Models are ranked by the proportion of variance explained (R^2). Graphic representations of multivariate models are shown in Figures 4.25 to 4.27.

The results showed that the multivariate models explained subjective visual comfort only slightly better than the single-variable models (R^2 values ranged from 0.28 to 0.32). All models have background luminance for the VDT view (L_{glo2}) as one of the predictors.

Table 4.9 Summary of longitudinal multiple regression analysis for predicting visual comfort sensation.

Model No.	Variable	Coefficients	
		β, γ, α	R^2
VM1	<i>SOL</i>	0.09	0.32*
	<i>L_{glo2}</i>	0.30	-
	<i>Constant</i>	0.38	-
VM2	<i>L_{win}</i>	0.23	0.28*
	<i>L_{glo2}</i>	0.22	-
	<i>Constant</i>	0.12	-
VM3	<i>L_{mxwin}</i>	0.29	0.28*
	<i>L_{glo2}</i>	0.19	-
	<i>Constant</i>	0.11	-

* $p < .01$

Subjective discomfort sensation could be estimated by applying the regression coefficients (β, γ) and constants (α) from Table 4.9 to the following magnitude estimation equation:

$$\Psi = \alpha V_1^\beta V_2^\gamma \quad (4.3)$$

where

- Ψ Discomfort glare sensation
- V_1 First variable in the model
- V_2 Second variable in the model
- α constant
- β, γ Exponents for the first and second variable

Using model number VM1 as an example, the subjective discomfort glare sensation could be estimated as a function of vertical solar radiation at window (*SOL*) and background luminance (*L_{glo2}*) from the following equation:

$$\Psi = 0.38 \cdot SOL^{0.09} \cdot L_{glo2}^{0.3} \quad (4.4)$$

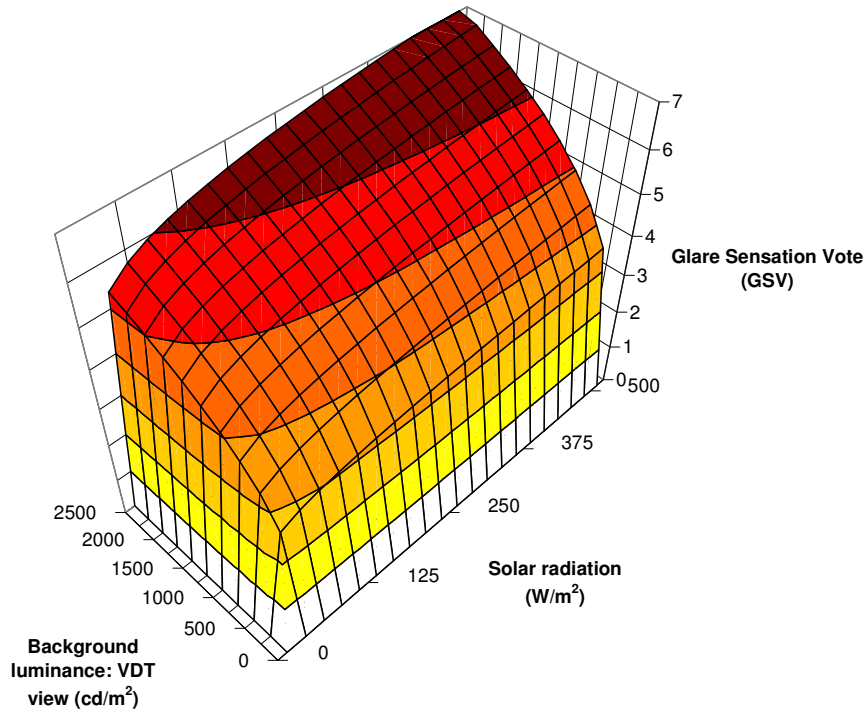

Figure 4.25 Multiple regression model of glare sensation as a function of background luminance (L_{glo2}) and solar radiation (SOL).

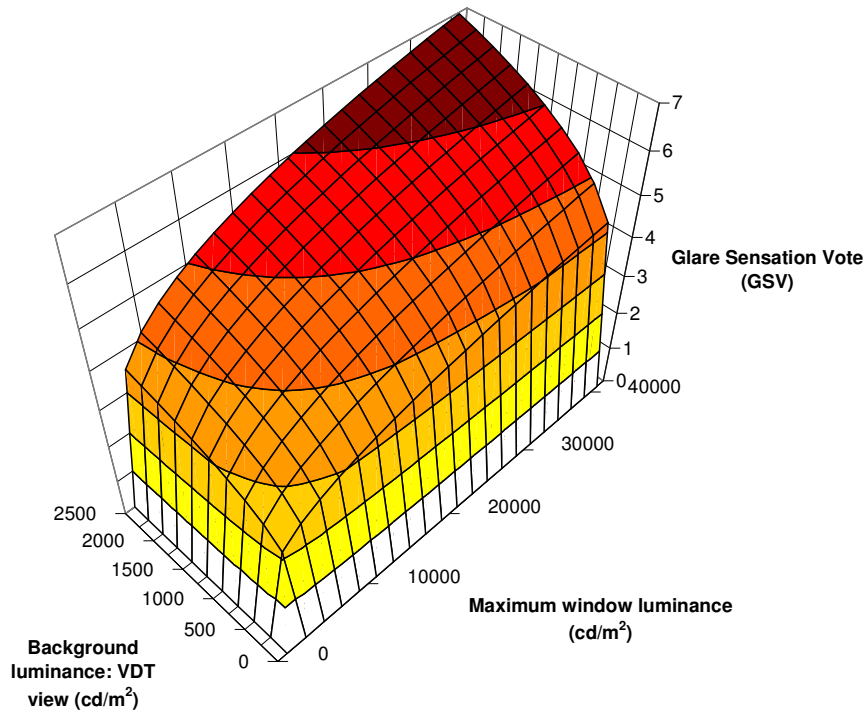

Figure 4.26 Multiple regression model of glare sensation as a function of background luminance (L_{glo2}) and Maximum window luminance (L_{mxwin}).

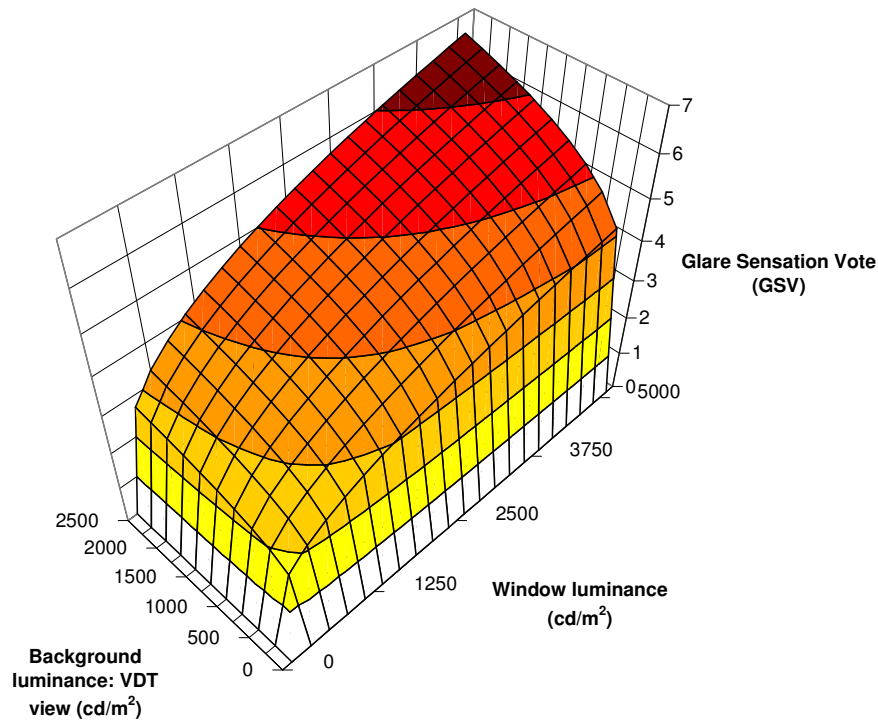

Figure 4.27 Multiple regression model of glare sensation as a function of background luminance (L_{glo2}) and window luminance (L_{win}).

Lastly, the results showed that all confounding factors which include direct sun penetration ($Disun$), Seating direction ($Divdt$), sky condition (SKY), and self-reported sensitivity to brightness (L_{sen}), were not statistically significant factors for the estimation of subjective discomfort glare sensation.

4.3.2.2 Thermal comfort

The perception of thermal discomfort increases as the magnitude of physical environmental predictors deviate from the thermal comfort zone, for example, extreme hot or cold temperature may cause thermal discomfort sensation. Because the air temperature (T_{air}) data collected were mostly above the comfort zone ($M = 73.6$ °F, $min = 68.0$ °F, $max = 80.1$ °F), therefore, this study only test the hypothesis that the sensation of

thermal discomfort will increase as the magnitude of physical environmental predictors increased.

The monitored variables were: air temperature (T_{air}), Mean Radiant Temperature (MRT) and solar radiation (SOL). Relative humidity (RH), direct sun penetration ($Disun$), and self-reported temperature sensitivity (T_{sen}) were treated as confounding factors. The results from each regression analysis are shown in Table 4.10. Models are ranked by proportion of variance explained (r^2).

Table 4.10 Summary of Regression Analysis for Variables Predicting Thermal Comfort Sensation

Model No.	Variable	Standard Regression		Random-effects GLS		GEE		r^2
		α	β	α	β	α	B	
T1	T_{air}	-20.59	0.28	-21.59	0.30	-21.82	0.30	0.42*
T2	SOL	-1.72	1.15	-1.52	1.04	-1.51	1.03	0.32*
T3	MRT	-12.00	0.16	-13.60	0.19	-14.03	0.19	0.26*

* $p < .01$

The best predictor for thermal comfort sensation was air temperature (T_{air}) which explained approximately 42% of the variance (see Figure 4.28). Solar radiation (SOL) and Mean Radiant Temperature (MRT) explained 32% and 26% of the thermal comfort sensation, respectively (see Figures 4.29 and 4.30). As before, the regression coefficients for the standard and longitudinal regression methods were comparable.

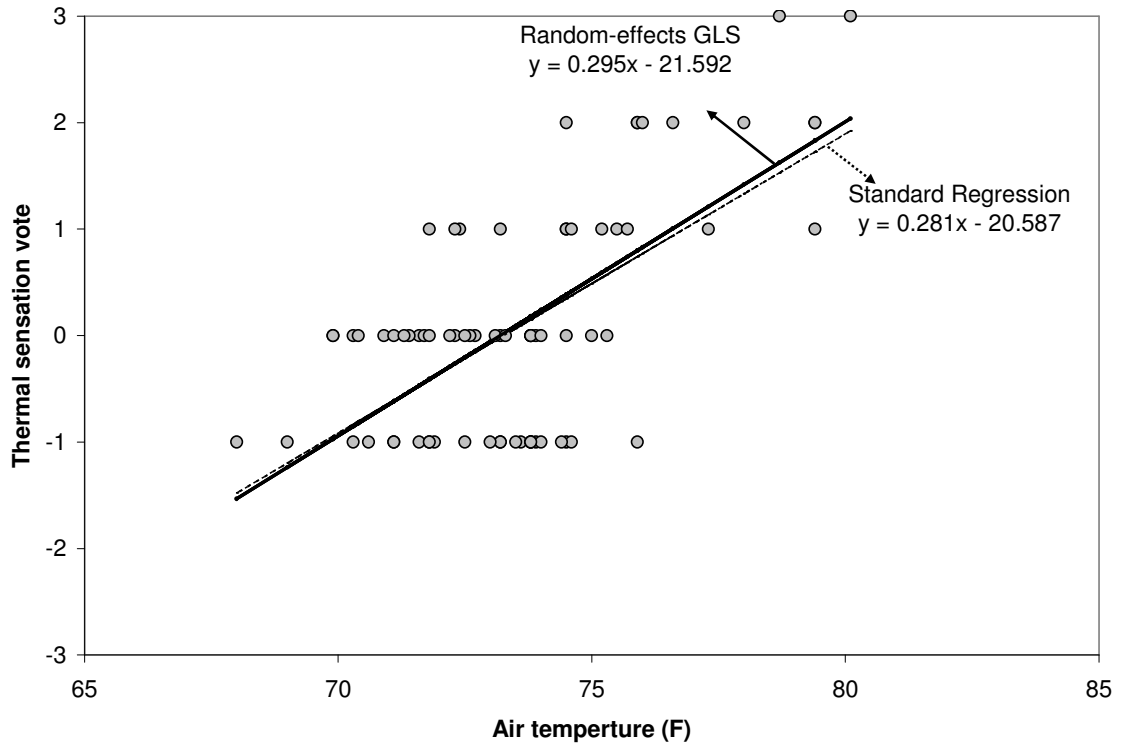

Figure 4.28 Scatterplot of thermal sensation as a function of air temperature (T_{air}).

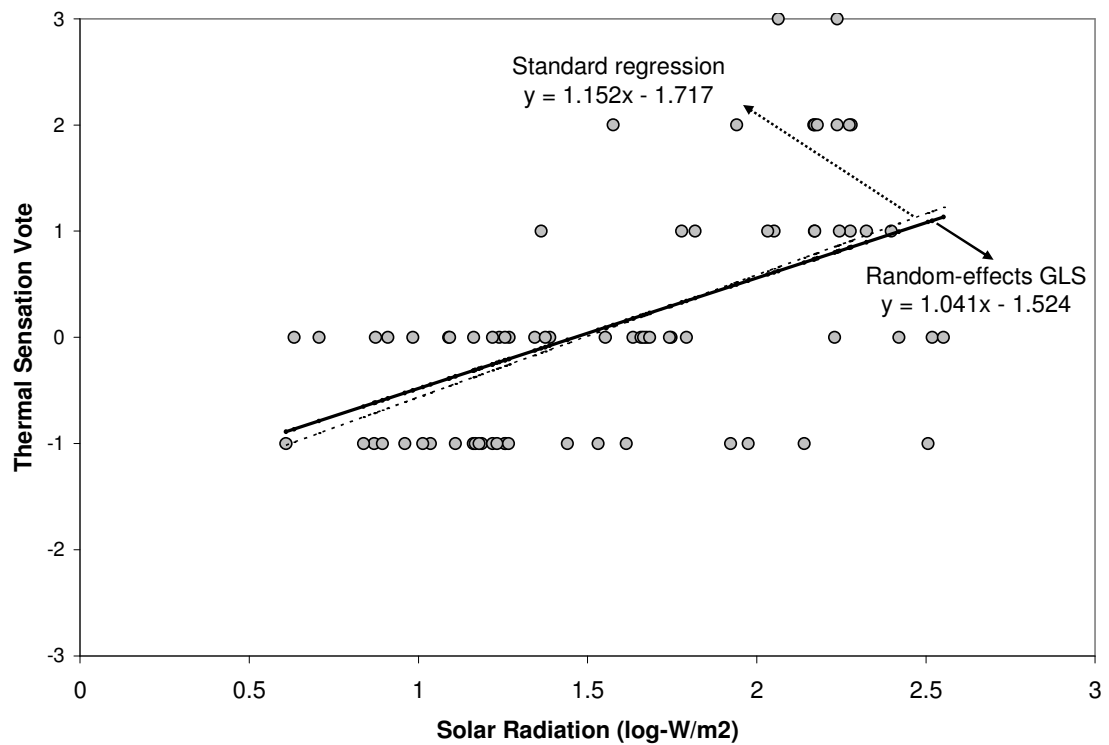

Figure 4.29 Scatterplot of thermal sensation as a function of vertical solar radiation at window ($SOL - \log W/m^2$).

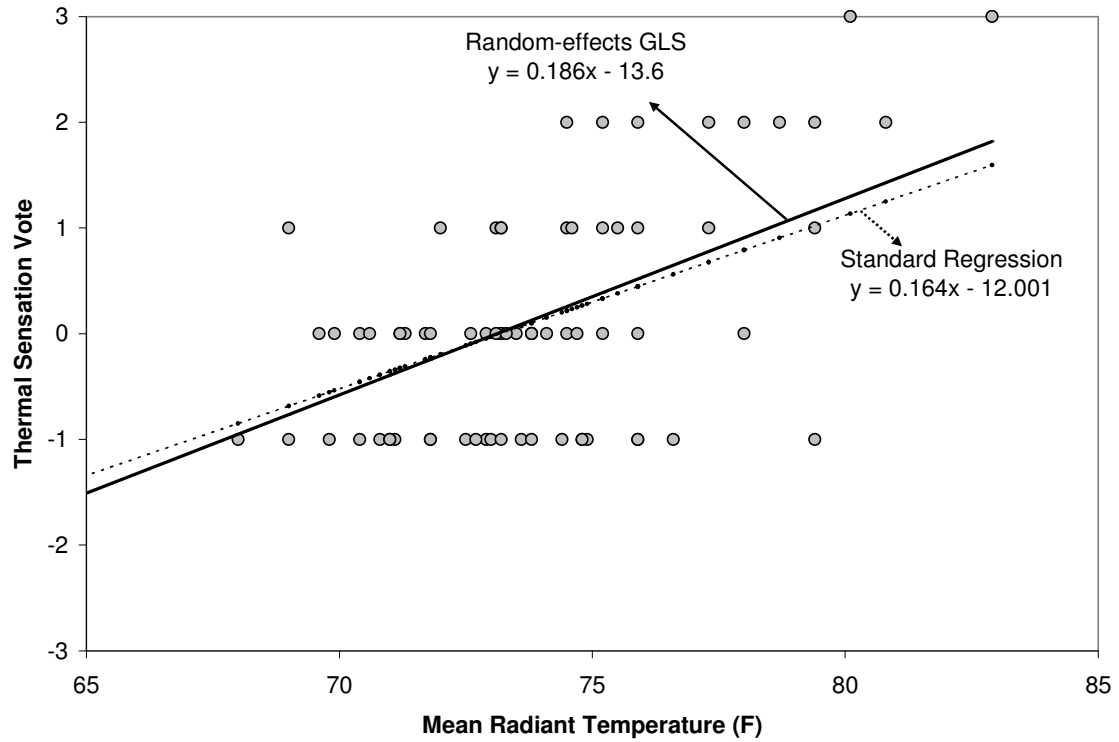

Figure 4.30 Scatterplot of thermal sensation as a function of Mean Radiant Temperature (*MRT*).

Table 4.11 Summary of Longitudinal Multiple Regression Analysis for Variables Predicting Thermal Comfort Sensation

Model No.	Variable	Coefficients α, β, γ	R^2
TM1	<i>SOL</i>	0.59	-
	<i>T_{air}</i>	0.22	-
	<i>Constant</i>	-16.86	0.51*
TM2	<i>T_{air}</i>	0.23	-
	<i>Disun</i>	0.59	-
	<i>Constant</i>	-17.19	0.48*
TM3	<i>SOL</i>	0.79	-
	<i>MRT</i>	0.14	-
	<i>Constant</i>	-11.12	0.44*
TM4	<i>MRT</i>	0.14	-
	<i>Disun</i>	0.83	-
	<i>Constant</i>	-10.34	0.42*

* $p < .01$

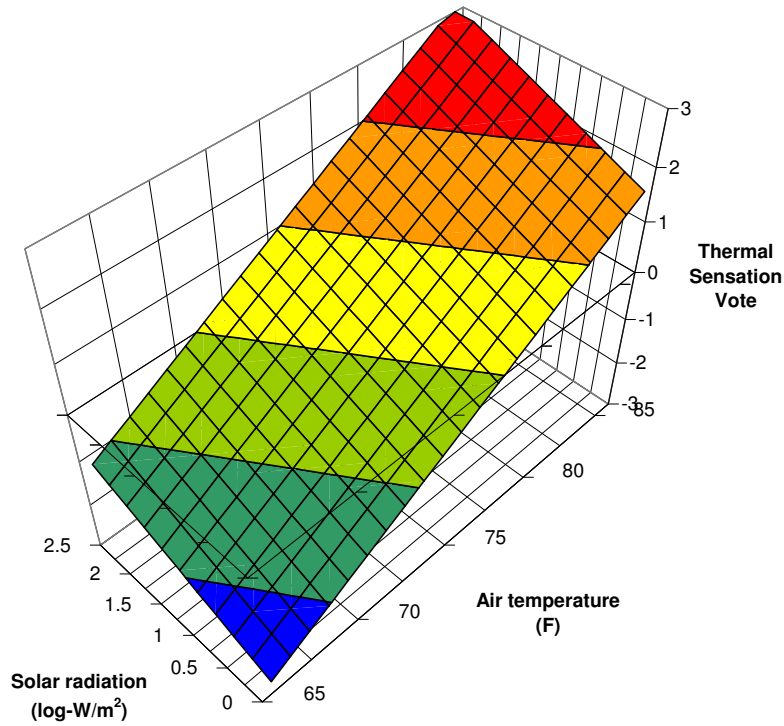

Figure 4.31 Multiple regression model of thermal sensation as a function of air temperature (T_{air}) and solar radiation (Sol).

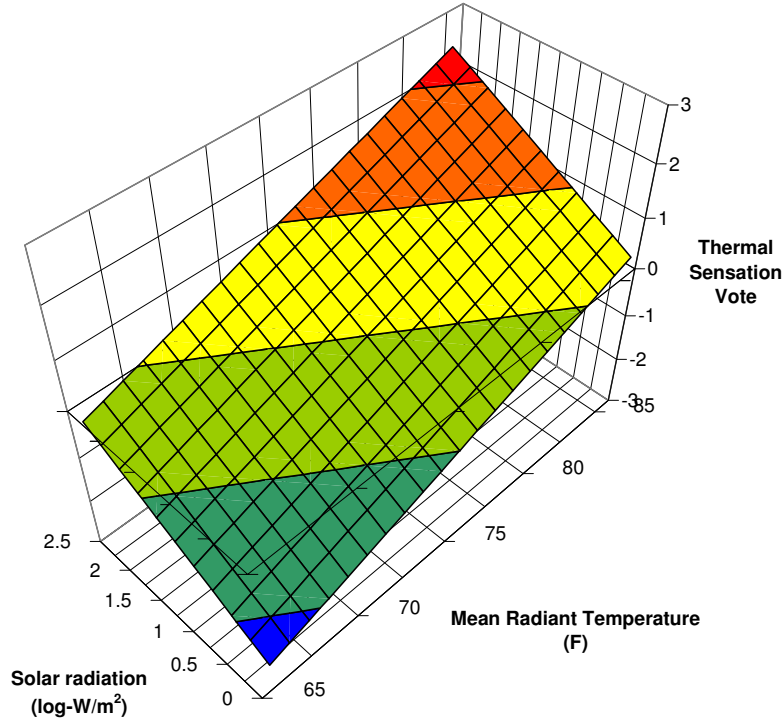

Figure 4.32 Multiple regression model of thermal sensation as a function of Mean Radiant Temperature (MRT) and solar radiation (Sol).

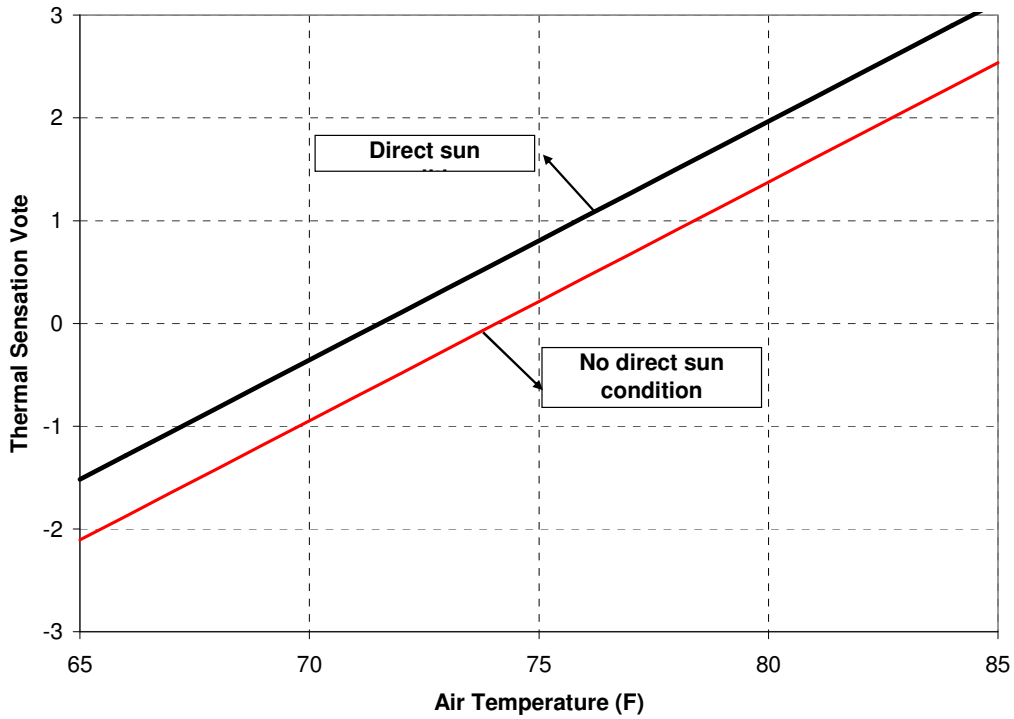

Figure 4.33 Regression model of thermal sensation as a function of air temperature (T_{air}) by direct solar penetration condition ($Disun$).

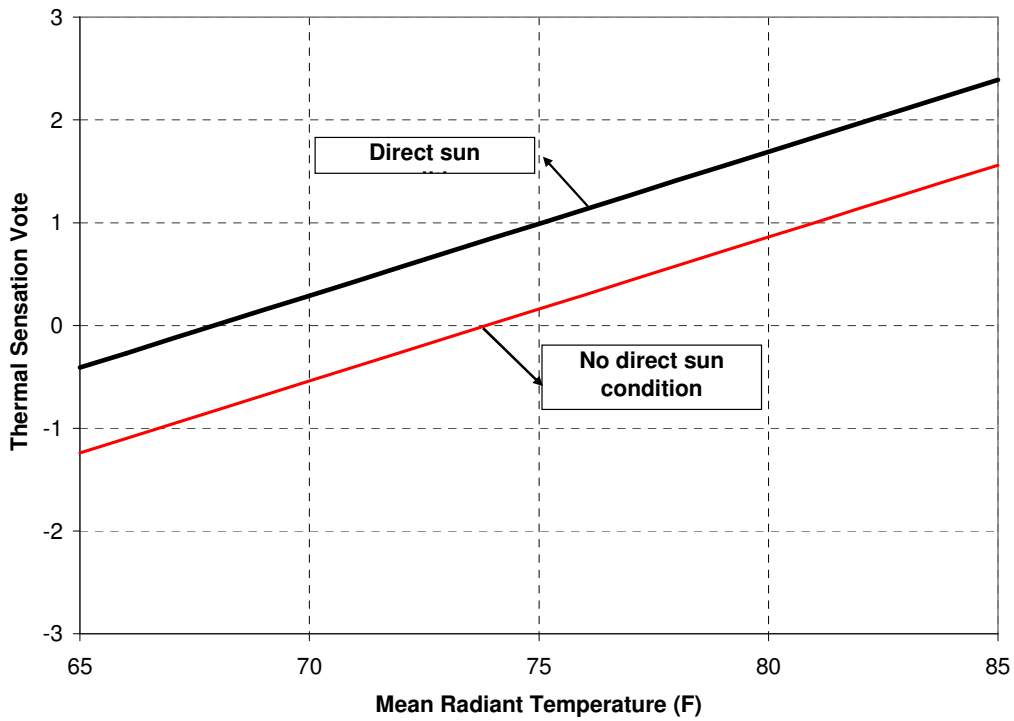

Figure 4.34 Regression model of thermal sensation as a function of MRT by direct solar penetration condition ($Disun$).

Table 4.11 shows four multivariate models for predicting thermal sensation. Models are ranked by the proportion of variance explained (R^2). The results showed that the multivariate models have higher correlation coefficients than the single variable models when the solar penetration predictor, either as a continuous variable (*SOL*) or a categorical variable (*Disun*), was added to the temperature predictor. The highest correlation coefficient occurred when air temperature (T_{air}) and solar radiation (*SOL*) were used as predictors (Multiple $R = .71$; Figure 4.31). Substitution of air temperature (T_{air}) with MRT in the model decreased the proportion of variance explained by 5% (see Figure 4.32).

When direct sun penetration (*Disun*) was added to the models (Model TM2 and TM4), thermal sensation was 0.59 to 0.83 points higher than when sun was not present under the same air temperature and MRT (see Figures 4.33 and 4.34).

4.3.3 Logistic window blind control models

The main hypothesis in this study was that window blind closing events could be predicted as a function of physical environmental conditions. To test this hypothesis and derive a window blind model, a longitudinal logistic regression was performed using physical environmental variables to predict window blind closing events.

4.3.3.1 Dependent variable: Window blind closing preference

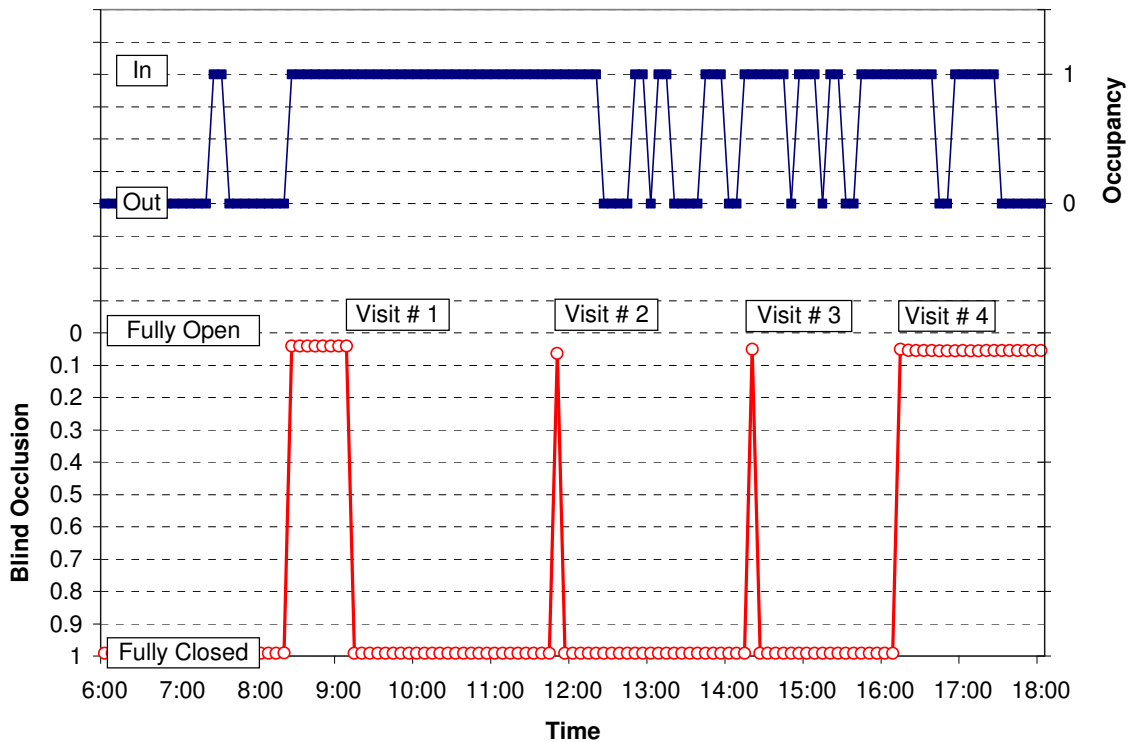

Figure 4.35 Example of window blind occlusion value and occupancy profile on day five of the field study.

Figure 4.35 shows an example of window blind occlusion value and occupancy data on day five of the field study, the real-time assessment of visual/thermal comfort, in which the participant was visited four times. The window blinds were raised to a fully open position at the beginning of each visit and participants were allowed to lower them after completing comfort assessment session. Analysis of the blind occlusion data showed that after each visit, most of the window blinds (94%) were lowered to a fully closed position, similar to the pattern shown in Figure 4.35. Only 6 % of the window blinds were closed half way. Analysis of window blind slat angle movement confirmed the survey results that the window blinds were rarely adjusted and most, if not all, of them were kept at a fully closed position (90 degree downward).

The chosen dependent variable for the window blind control logistic model was the window blind closing state (yes =1, no =0). To simplify the analysis process, if the occupants prefer to have their window blinds closed after the comfort assessment session, based on the occlusion data, it is assumed the window blinds and slat angle would be set to a fully closed position.

4.3.3.2 Selection of independent variables

The variable selection criteria were:

1) The variables should represent why building occupants close their blinds

The survey data showed that building occupants report that they control their window blinds primarily for visual comfort (luminance related) reasons. Therefore, thermal comfort variables such as air temperature and MRT were treated as confounding factors instead of as main predictors.

2) The variables should correlate moderately with subjective responses

Results from the regression analysis between subjective responses and physical data were presented in Section 4.3.2. The results showed that luminance data from the Photolux systems were better at explaining subjective visual comfort responses than luminance data from the Li-Cor illuminance sensors. Therefore, the luminance variables selected for the logistic regression model were: maximum window luminance (L_{mxwin}), average window luminance (L_{win}), and vertical solar radiation at window (SOL).

Results from Table 4.6 also showed that the background luminances measured from two viewpoints (looking at computer and looking at window) were highly correlated. In order to eliminate multicollinearity, only background luminance from

window view (L_{glo1}) which explains more variance in subjective responses, was included in the logistic regression analysis. Because of low correlations, luminance data from Li-Cor illuminance sensors (L_{glo3} , L_{win3}) and workplane illuminance (E_{work}) were not included in the logistic regression analysis.

3) The variables were suggested in previous research

The variables that were suggested in previous window blind research included two contextual factors: sky conditions (SKY) and direct solar penetration ($Disun$). In addition, based on the adaptive comfort theory, individual's self-reported sensitivity to brightness (L_{sen}) and temperature (T_{sen}) were included as confounding factors.

4) The variables should have Variance Inflation Factors (VIF) less than 10

Table 4.12 describes the multicollinearity diagnostics for the variables that were selected based on the above-mentioned criteria. All of the variables' VIFs were below the initial cut-off score of 10.

Table 4.12 Multicollinearity Diagnostics for Selected Predictor and Confounding Variables

Variable	VIF		VIF*
Predictors		Predictors	
L_{glo1}	5.66	L_{glo1}	5.34
L_{win}	6.99	L_{win}	7.32
L_{mxwin}	6.46	L_{mxwin}	6.44
$Solar$	3.58	$Solar$	3.57
Confounding factors		Confounding factors	
T_{air}	2.7	MRT	1.77
L_{sen}	1.68	L_{sen}	1.69
T_{sen}	1.85	T_{sen}	1.68
$Disun$	2.49	$Disun$	2.38
SKY	1.77	SKY	1.76
Mean VIF	3.69	3.69	3.55

* Substituted T_{air} with MRT

4.3.3.3 Descriptive information

Descriptive statistics for each of selected independent variables by window blind closing preference are summarized in Table 4.13. All variables except for air temperature (T_{air}) and MRT were transformed into log-scale. The t test for independent means was conducted and the results confirmed that each environmental condition was significantly higher (when blinds were fully opened) when participants wanted to close their blinds versus no change.

Table 4.13 Descriptive Statistics of Selected Independent Variables by Window Blind Closing Preference

Variable	Want no change				Want to close				t value
	Mean	SD	Min	Max	Mean	SD	Min	Max	
L_{glo1}	2.38	0.19	2.10	2.79	2.71	0.33	2.12	3.42	4.50**
L_{win}	2.97	0.26	2.43	3.43	3.30	0.27	2.68	3.76	5.03**
L_{mxwin}	3.61	0.29	3.03	4.11	4.05	0.28	3.39	4.53	6.37**
SOL	1.21	0.35	0.61	2.03	1.74	0.52	0.71	2.55	4.25**
T_{air}	72.13	1.87	68.00	75.30	74.10	2.47	70.30	80.10	3.29**
MRT	72.41	2.70	68.00	79.40	74.18	3.45	64.20	82.90	2.11*

* $p < .05$, ** $p < .01$

Table 4.14 Frequency of Window Blind Closing Preferences by Direct Sun Penetration Condition

Preference	Direct Sun Penetration Level		Total
	No direct sun	Direct sun	
No change	21	2	23
Want to close	30	13	60
Total	51	15	83

Table 4.15 Frequency of Window Blind Closing Preferences by Sky Condition

Preference	Sky Condition		Total
	Cloudy	Sunny	
No change	6	17	23
Want to close	7	53	60
Total	13	70	83

The same preferences were also examined under direct sun penetration and sky condition levels (see Tables 4.14 and 4.15). Table 4.14 shows that the frequencies of window blind position preference were not randomly distributed across each direct sun penetration category ($\chi^2 (1, n = 83) = 11.97, p < 0.001$; Fisher's Exact test $p < 0.001$). It can be interpreted that, for the field study sample, direct sun penetration influenced the window blind closing preference. Therefore, the direct sun penetration variable (*Disun*) was included in the logistic regression analysis.

The frequency distribution of window blind position preference, however, was not different between the two sky conditions ($\chi^2 (1, n = 83) = 2.62, p = 0.11$). These results disagree with Rea's (1984) findings as well as the survey results from the current study. This may be the result of limited data in the cloudy sky condition. Because weather could not be manipulated, the field study data were collected primarily during the sunny sky conditions. Due to these limitations, sky condition was dropped from further analysis.

4.3.3.4 Single variable models

The logistic regression coefficients for each predictor variable are summarized in Table 4.16. For the standard regression, Nagelkerke's r^2 , which is based on likelihood, is shown (Nagelkerke, 1991). The percentage of correct prediction, tallied from the model's estimates, is also shown for comparison. For the GEE models, the regression coefficients, the Wald statistic, the within-subject correlation (XTcorr), and the Akaike Information Criterion (AIC) value for each independent variable are shown.

The significance tests for each logistic regression model were based on the Wald statistic, which is defined as the square of the ratio between the regression coefficient and its standard error. This statistic follows a χ^2 distribution with one degree of freedom.

Support was found for the current study's main hypothesis that window blind closing events can be predicted as a function of physical environmental predictors. The results showed that window blind closing events increased as the luminance and vertical solar radiation levels increased. The logistic regression curves from the standard regression method (dash line) and the GEE method (solid line) are shown in Figures 4.36 to 4.39.

Data from Table 4.16 also showed that the logistic regression coefficients between two regression methods were comparable for luminance related variables and only slightly different for vertical solar radiation variables. Therefore, the Nagelkerke's r^2 and the percentage of correct prediction were also used to compare the model's goodness-of-fit.

Table 4.16 Summary of Logistic Regression Analysis for Variables Predicting Window Blind Closing Events

Variable	Standard Regression						GEE		
	β, α	LR	r^2	% correct	AIC	ROC Area	β, α	Wald	XTcorr
L1 <i>L_{mxwin}</i>	4.93	30.47*	0.44	80.7	71.5	0.86	4.69	28.63*	0.16
Constant	-17.95						-17.15		
L2 <i>SOL</i>	2.44	16.67*	0.29	72.6	73.0	0.78	2.59	22.65*	0.46
Constant	-2.58						-2.89		
L3 <i>L_{glo1}</i>	4.86	21.37*	0.33	78.3	80.6	0.80	4.95	15.79*	0.21
Constant	-11.29						-11.58		
L4 <i>L_{win}</i>	4.37	21.15*	0.33	73.5	80.8	0.80	4.36	23.12*	0.19
Constant	-12.75						-12.83		

* $p < .01$

Using the AIC measure, the results from Table 4.16 show that the model with maximum window luminance (L_{mxwin}) as a predictor (Model L1) has the smallest AIC criterion measure (71.5). Base on AIC, this model is considered to be the preferred single variable model for predicting window blind closing events. The model with the largest AIC criterion measure is Model L4 which use average window luminance (L_{win}) as a predictor (AIC = 80.8)

The model with maximum window luminance (L_{mxwin}) as a predictor (Model L1) also has the highest coefficient of determination ($r^2 = 0.44$) as well as the highest percentage of correct prediction (80.7%). The model with solar radiation (SOL) as a predictor (Model L2) has the lowest coefficient of determination ($r^2 = 0.29$) and the lowest percentage of correct prediction (72.6%).

The probability of window blind closing event could be estimated by applying the regression coefficient and constant from Table 4.16 to the following probability equation:

$$P(X) = \frac{e^{-(\alpha+\beta X)}}{1 + e^{-(\alpha+\beta X)}} \quad (4.5)$$

where

$P(X)$ Probability of window blind closing

α, β estimated regression coefficients

Using Model L2 as an example, the probability of window blind closing events could be estimated as a function of vertical solar radiation at window (SOL) from the following equation:

$$P(X) = \frac{e^{-(-2.89+[2.59 \cdot SOL])}}{1 + e^{-(-2.89+[2.59 \cdot SOL])}} \quad (4.6)$$

Graphical representation of this model is presented in Figure 4.37.

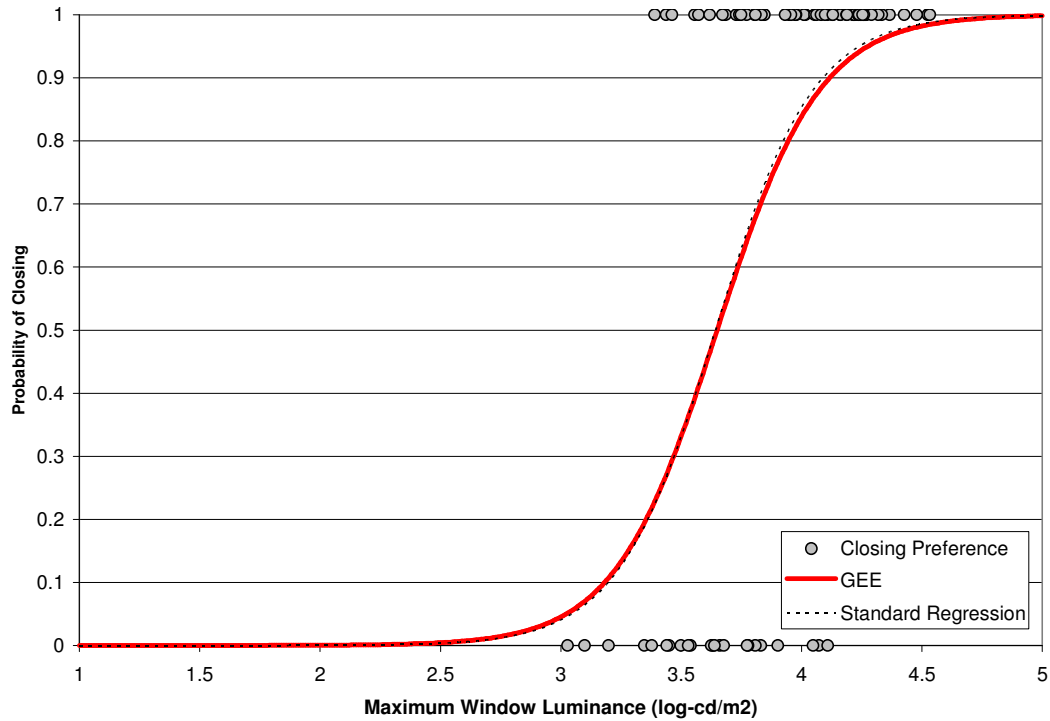

Figure 4.36 Model L1, logistic model of window blind closing events as a function of maximum window luminance (L_{mxwin} ; expressed in log scale).

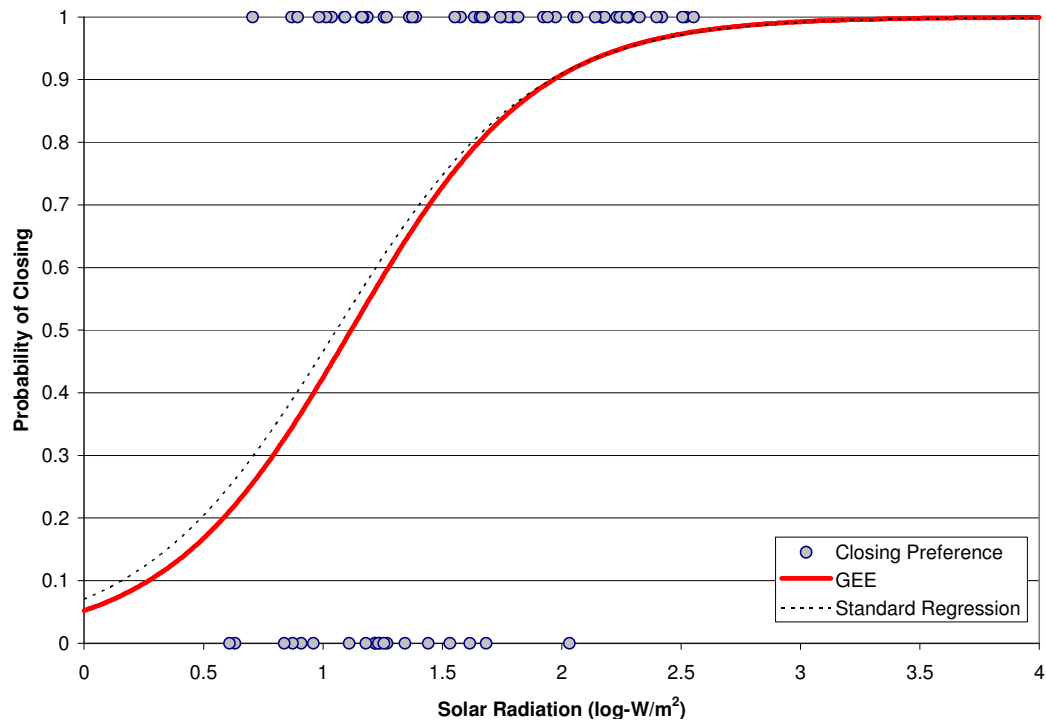

Figure 4.37 Model L2, logistic model of window blind closing events as a function of vertical solar radiation at the window (SOL ; expressed in log scale).

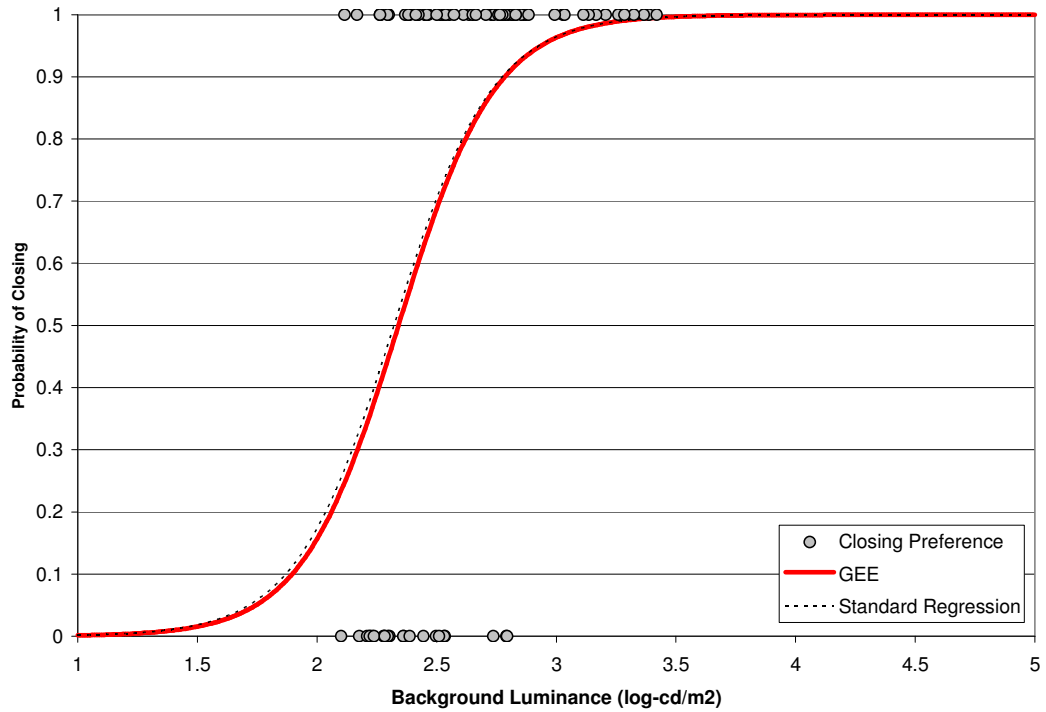

Figure 4.38 Model L3, logistic model of window blind closing events as a function of background luminance (L_{glo1} ; expressed in log scale).

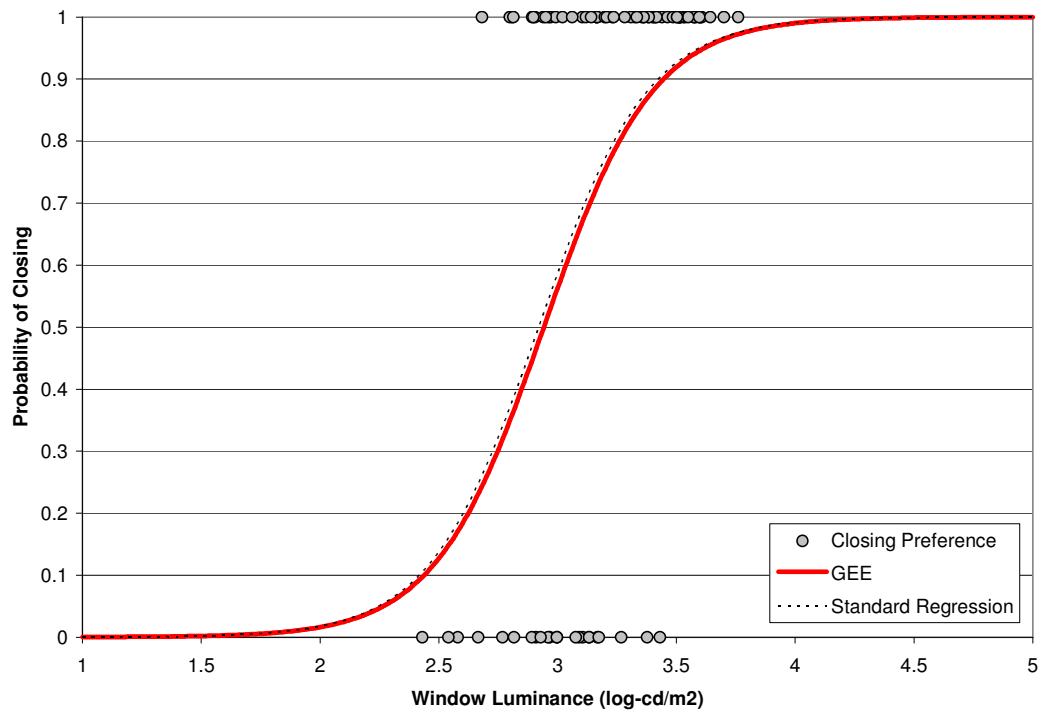

Figure 4.39 Model L4, logistic model of window blind closing events as a function of average window luminance (L_{win} ; expressed in log scale).

Table 4.17 shows the threshold luminance or vertical solar radiation values at probability of 0.5 (calculated from Equation 4.5 for each variable). These threshold values could be directly applied in predictive window blind control algorithms and energy simulation programs.

Table 4.17 Estimated Threshold Values (at $p = 0.5$) for Various Physical Environmental Predictors

Variable (unit)	Threshold Value
Maximum window luminance (cd/m^2)	4,466
Vertical solar radiation (W/m^2)	13
Background luminance (cd/m^2)	225
Average window luminance (cd/m^2)	890

4.3.3.5 Multivariate models

The survey results showed that window blind closing behavior was influenced by a combination of visual and thermal reasons. Therefore, multivariate models of window blind closing behavior were derived by using multiple logistic regression techniques.

In this research, air temperature (T_{air}) and direct sun penetration ($Disun$) were considered to be confounding factors. In addition, it was hypothesized that participants' self-reported sensitivity to brightness and temperature (L_{sen} and T_{sen} , respectively) would influence window blind closing behavior. These variables were entered to the existing single-variable regression models in a series of steps, adding or removing one variable at a time. Because coefficient of determination cannot be calculated with the GEE technique, the model's goodness-of-fit was measured by the Akaike Information Criterion (AIC) from standard regression technique.

Table 4.18 summarizes the results from the two multiple logistic regression techniques. Models are ranked by the AIC. A total of 9 multivariable logistic regression models were derived ($p < .01$). Model M1 was derived by the backward elimination technique. Models M2 to M9 were derived by the forward selection technique. Based on the AIC, window blind closing events are best predicted by the backward elimination model (Model M1; AIC = 48.2). In this model, the window blind closing events are predicted as a function of average window luminance (L_{win}), maximum window luminance (L_{mxwin}), vertical solar radiation at window (SOL) and participants' brightness sensitivity (L_{sen}).

Nagelkerke's r^2 and the percentage of correct prediction were also used to justify the model's goodness-of-fit. The backward elimination model (Model M1) has the highest Nagelkerke's R^2 (0.69) and the highest percentage of correct prediction (89%). Model M9 which predicts window blind closing events as a function of average window luminance (L_{win}) and direct sun penetration ($Disun$) was found to have the lowest Nagelkerke's R^2 (0.36) and the lowest percentage of correct prediction (73.5%).

The probability of window blind closing event could be estimated by applying the regression coefficient and constant from Table 4.18 to the following equation:

$$P(X) = \frac{e^{-(\alpha + \sum \beta_i X_i)}}{1 + e^{-(\alpha + \sum \beta_i X_i)}} \quad (4.7)$$

where

$P(X)$ Probability of window blind closing

α, β estimated regression coefficients

Using Model M2 as an example, the probability of window blind closing events could be estimated as a function of vertical solar radiation at window (SOL) and occupants' brightness sensitivity (L_{sen}) from the following equation:

$$P(X) = \frac{e^{-(-8.94+[3.22 \cdot SOL]+[1.22 \cdot L_{sen}])}}{1 + e^{-(-8.94+[3.22 \cdot SOL]+[1.22 \cdot L_{sen}])}} \quad (4.8)$$

Graphical representation of this model is shown in Figure 4.40.

Data in Table 4.18 support the hypothesis that participants' self-reported brightness sensitivity (L_{sen}), MRT, and direct sun penetration ($Disun$) influence window blind control behavior. Participants' temperature sensitivity (T_{sen}), however, was not found to be a significant confounding factor.

Figures 4.41 to 4.46 show a few more examples of these multivariable logistic models with luminance-related variables as the main predictors. The MRT, participants' brightness sensitivity, and direct sun penetration were used as confounding factors in these models respectively. Model M1 and M6 were too complex to present graphically and therefore were not shown in these examples.

Table 4.18 Summary of Multiple Logistic Regression Analysis Predicting Window Blind Closing Events

No.	Variable	Standard Regression						GEE		
		β, α	LR	R^2	% Correct	AIC	ROC Area	β, α	Wald	XT-Corr
M1	L_{win}	-5.76	47.48*	0.69	89.0	48.2	0.95	-5.82	58.67*	0.09
	L_{mxwin}	5.96						6.20		
	SOL	3.30						3.29		
	L_{sen}	1.22						1.22		
	Constant	-13.94						-14.66		
M2	SOL	3.09	40.90*	0.62	86.3	50.8	0.92	3.22	13.82*	0.14
	L_{sen}	1.22						1.22		
	Constant	-8.71						-8.94		
M3	L_{mxwin}	5.19	33.64*	0.53	84.0	61.3	0.89	4.87	21.77*	0.26
	MRT	0.25						0.25		
	Constant	-36.87						-35.92		
M4	L_{mxwin}	4.47	41.76*	0.57	84.3	62.2	0.89	4.76	31.33*	0.05
	L_{sen}	0.72						0.72		
	Constant	-20.25						-20.66		
M5	L_{glo1}	5.22	37.79*	0.53	84.3	66.2	0.88	5.31	20.02*	0.04
	L_{sen}	0.86						0.86		
	Constant	-16.11						-16.35		
M6	L_{win}	2.18	31.16*	0.52	86.7	68.8	0.88	2.44	20.68*	0.12
	$Disun$	1.98						1.89		
	L_{sen}	0.80						0.79		
	Constant	-10.07						-10.87		
M7	L_{win}	4.46	23.98*	0.40	76.0	70.9	0.84	4.45	14.49*	0.26
	MRT	0.21						0.23		
	Constant	-28.53						-30.31		
M8	L_{win}	3.57	32.53*	0.47	84.3	71.4	0.86	3.77	21.92*	0.09
	L_{sen}	0.68						0.68		
	Constant	-13.38						-14.04		
M9	L_{win}	3.45	23.82*	0.36	73.5	80.2	0.82	3.33	52.68*	0.23
	$Disun$	1.32						1.28		
	Constant	-10.18						-9.94		

* $p < .01$

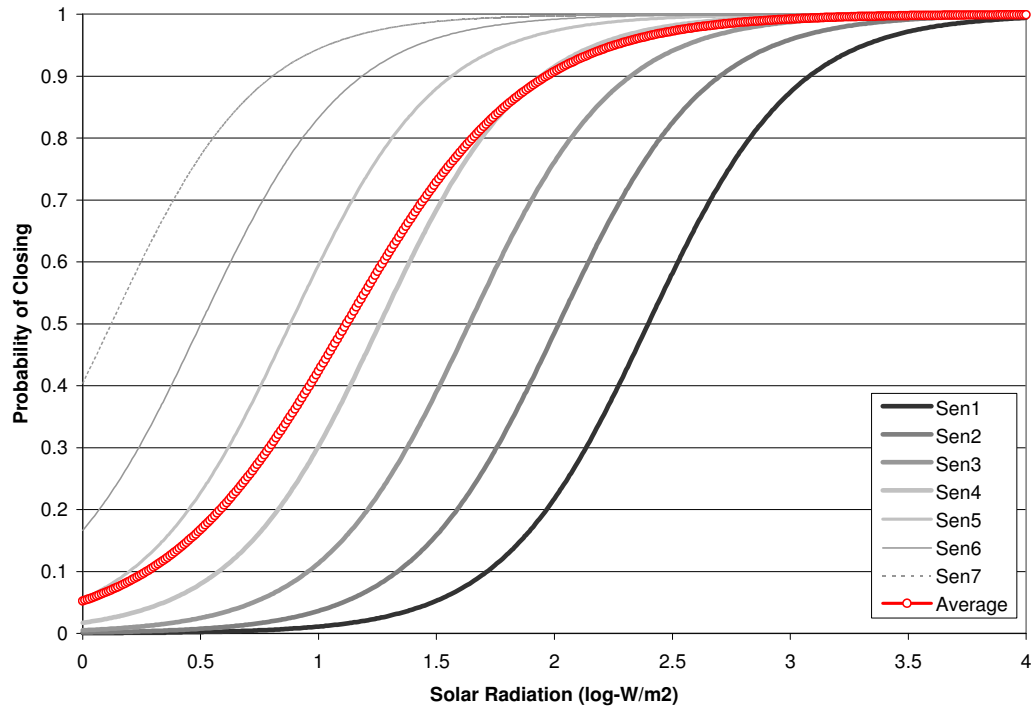

Figure 4.40 Model M2, logistic model of window blind closing as a function of vertical solar radiation (SOL) and brightness sensitivity (L_{sen}).

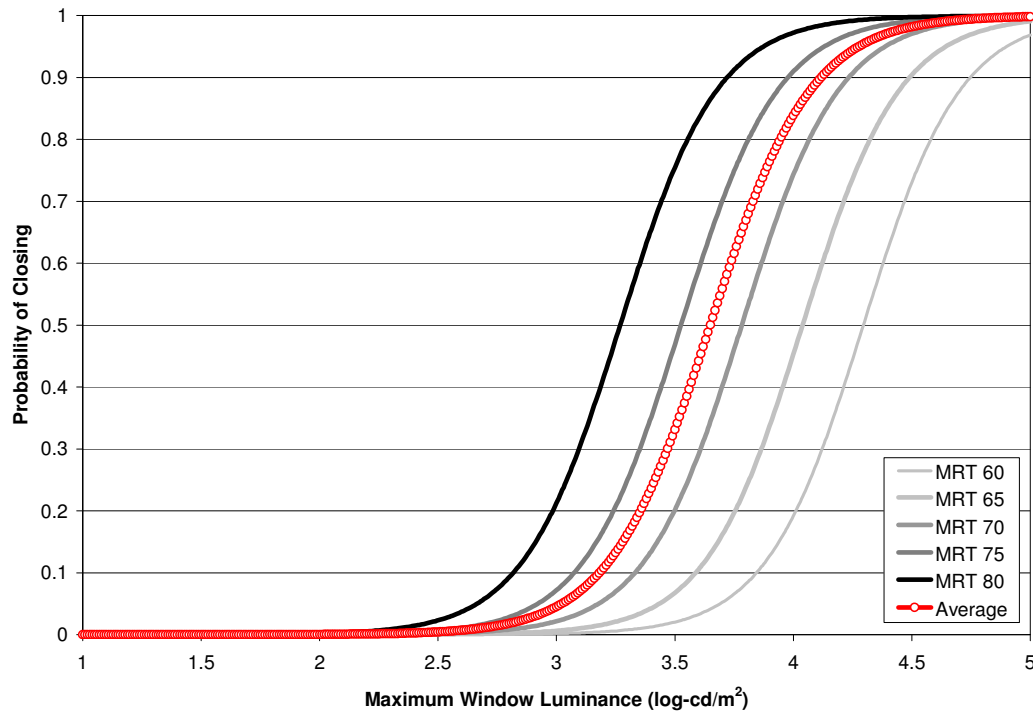

Figure 4.41 Model M3, logistic model of window blind closing as a function of maximum window luminance (L_{mxwin}) and Mean Radiant Temperature (MRT).

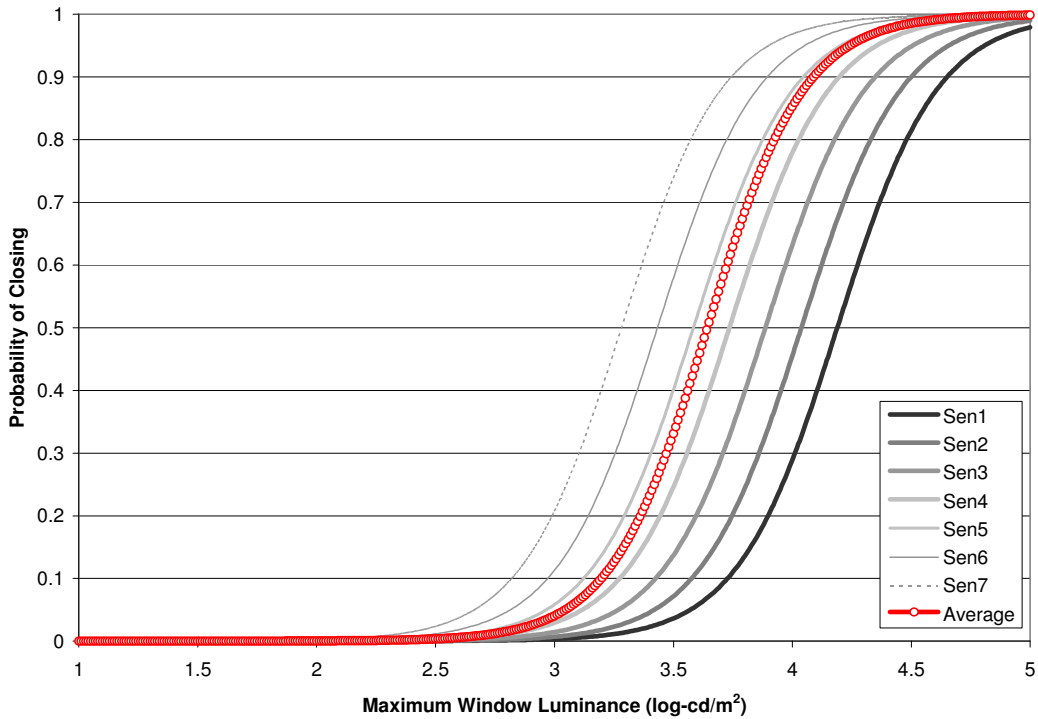

Figure 4.42 Model M4, logistic model of window blind closing as a function of maximum window luminance (L_{mxwin}) and brightness sensitivity (L_{sen}).

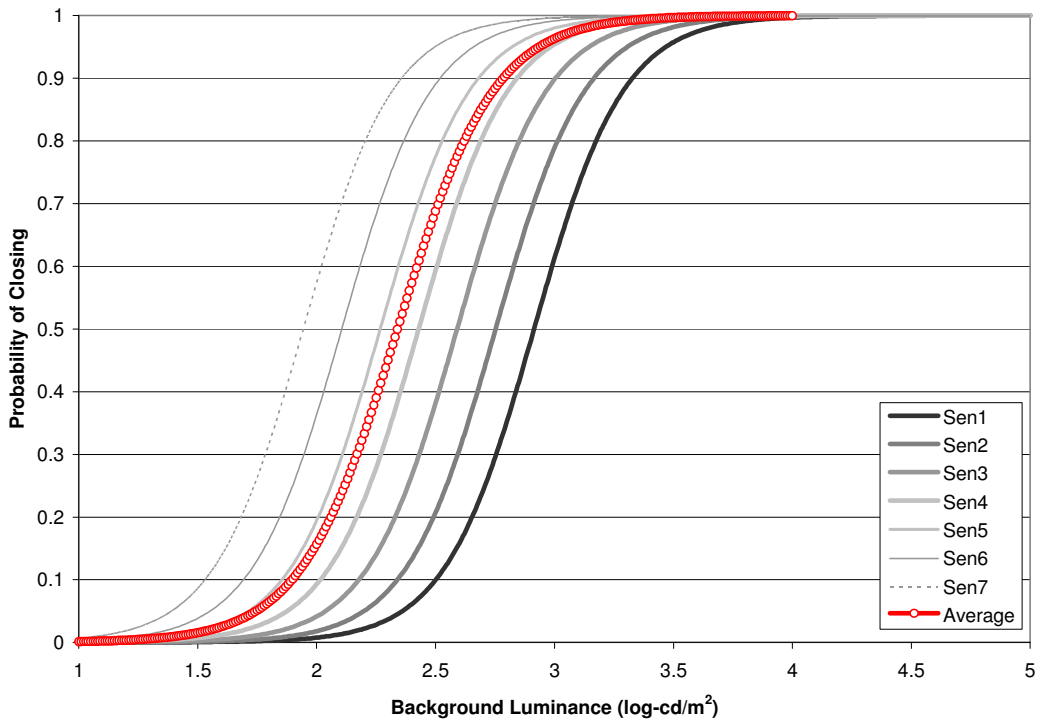

Figure 4.43 Model M5, logistic model of window blind closing as a function of background luminance (L_{glo1}) and brightness sensitivity (L_{sen}).

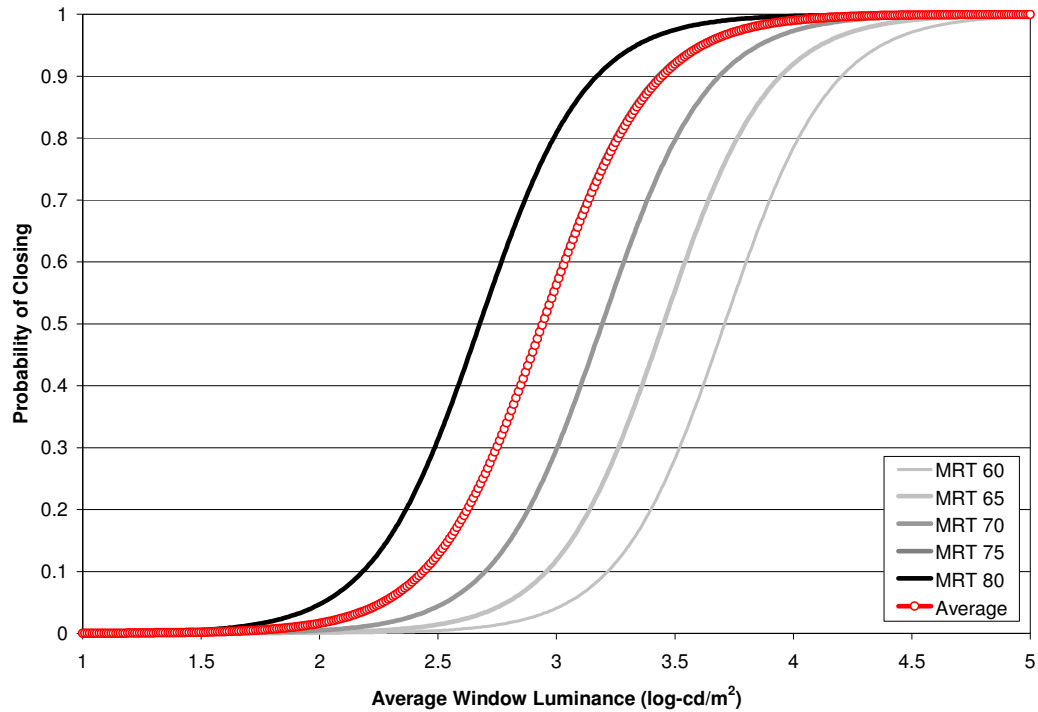

Figure 4.44 Model M7, logistic model of window blind closing as a function of average window luminance (L_{win}) and Mean Radiant Temperature (MRT).

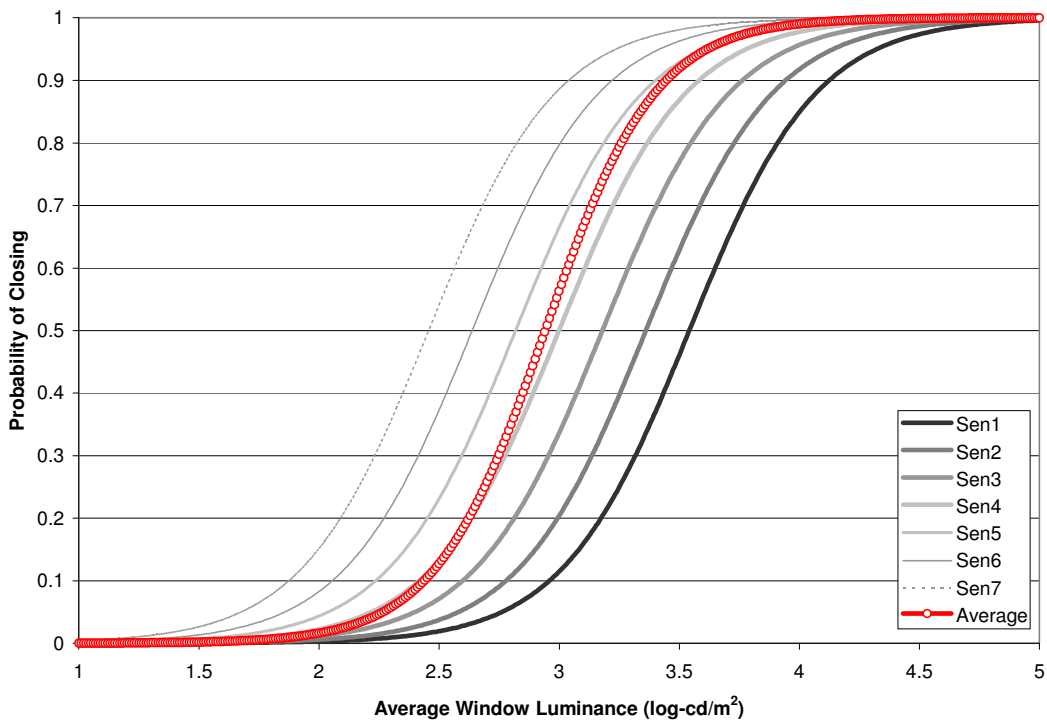

Figure 4.45 Model M8, logistic model of window blind closing as a function of window luminance (L_{win}) and brightness sensitivity (L_{sen}).

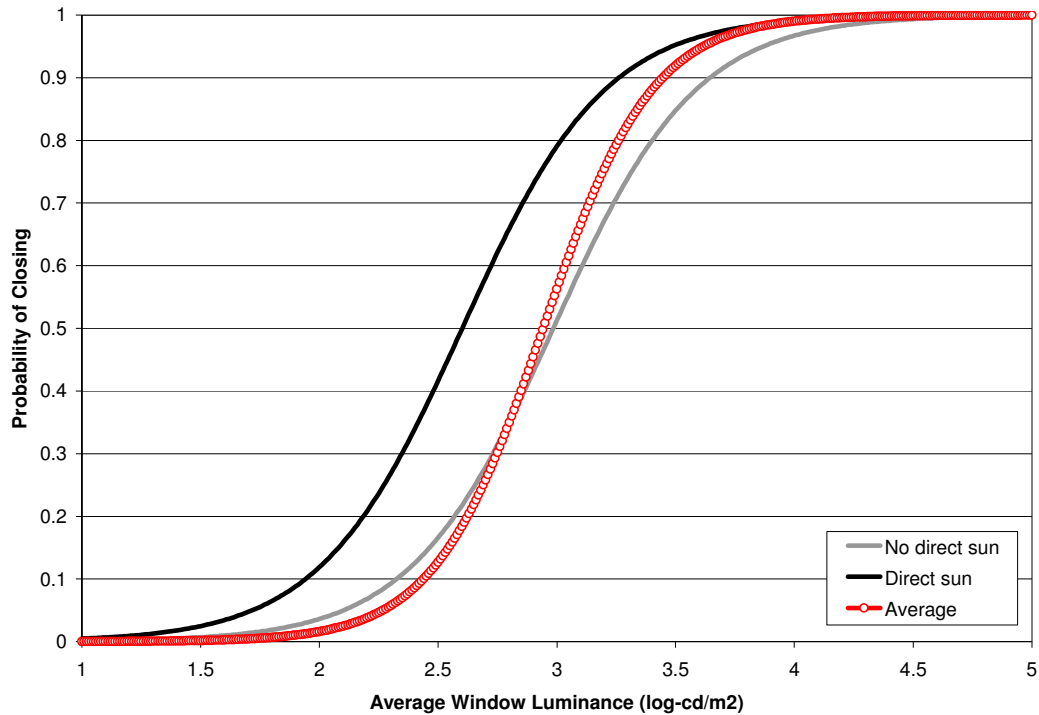

Figure 4.46 Model M9, logistic model of window blind closing as a function of average window luminance (L_{win}) and direct sun penetration ($Disun$).

Table 4.19 summarizes a few examples of estimated threshold values for various models with different levels of confounding factors. These threshold values were calculated from Equation 4.7. Alternatively, they can be extracted from Figures 4.40 to 4.46.

The data in Table 4.19 showed that for Models M2, M4, M5, and M8, the threshold values increase as the occupants' sensitivity to brightness decrease. Similar trend was found for Models M3 and M7, where the threshold values increase as the Mean Radiant Temperature (MRT) decrease. The explanation is simpler for Model M9 in which the threshold value was found to be higher when there is no direct sun penetration in the space.

Table 4.19 Estimated Threshold Values (at $p = 0.5$) for Different Levels of Confounding Factors

Confounding Factor x Main Predictor		Threshold Values						
M2	Brightness sensitivity	1	2	3	4	5	6	7
	Solar (W/m^2)	250	105	45	20	8	3.3	1.3
M3	Mean Radiant Temp. ($^{\circ}F$)			65	70	75	80	
	Max window lum. (cd/m^2)			10,950	6,165	3,380	1,860	
M4	Brightness sensitivity	1	2	3	4	5	6	7
	Max window lum. (cd/m^2)	15,480	10,950	7,760	5,495	3,800	2,750	1,920
M5	Brightness sensitivity	1	2	3	4	5	6	7
	Background lum. (cd/m^2)	810	560	389	269	185	130	90
M7	Mean Radiant Temp. ($^{\circ}F$)			65	70	75	80	
	Ave. window lum. (cd/m^2)			2,090	1,230	710	415	
M8	Brightness sensitivity	1	2	3	4	5	6	7
	Ave. window lum. (cd/m^2)	3,550	2,290	1,550	1,000	660	435	290
M9	Direct sun penetration	No direct sun			Direct sun			
	Ave. window lum. (cd/m^2)	980			410			

4.3.4 Summary of results from the window blind usage field study

The first stage of analysis in the field study involved testing whether visual and thermal comfort could be predicted from physical environmental conditions. The second stage involved testing whether window blind closing events could be predicted from physical environmental conditions. The results from the window blind usage field study can be summarized as follows:

1. Visual comfort sensation was moderately correlated with maximum window luminance (L_{mxwin}), average window luminance (L_{win}), background luminance (L_{glo1}), and transmitted vertical solar radiation at window (SOL). This finding agrees with previous visual comfort studies (Osterhaus & Bailey, 1991; Osterhaus, 1998; Loe et al., 2000; Aries, 2003; Fisekis et al., 2003). Single variable and multivariate models were derived in this study. The results showed that maximum window luminance (L_{mxwin}) and average window luminance (L_{win}) were the best visual comfort prediction models.

The best multivariate model, which predicted visual comfort sensation based on the vertical solar radiation at window (*SOL*) and background luminance VDT view (*L_{glo2}*), explains only slightly more variance than the best single-predictor model.

2. Thermal comfort sensation was moderately correlated with air temperature (*T_{air}*), Mean Radiant Temperature (*MRT*), and vertical solar radiation (*SOL*). The results showed that air temperature (*T_{air}*) was the best thermal comfort prediction model for the limited range of thermal conditions examined in this study. The multivariate model predicting thermal comfort sensation as a function of vertical solar radiation (*SOL*) and air temperature (*T_{air}*) explained thermal sensation variance 10% more than the best single variable model.

3. A comparison between glare predictions (Figure 4.24) from calculated *DGI_f* (the present field study) and the original glare criteria (laboratory studies conducted elsewhere) suggests that adaptation may influence how building occupants rate their level of glare sensation. The data suggested that building occupants can tolerate more glare from an actual large glare source (window) than from a simulated glare source. Previous research hypothesized that the effect may be due to the physiological and psychological adaptation (Humphreys & Nicol, 1998) and view content (Boubekri & Boyer, 1992). These hypotheses were not tested in this study.

4. The results supported the main hypothesis of the current research: the probability of window blind closing events is a function of physical environmental conditions. Based on the correlation coefficients from the present field study, survey results, and previous studies, a set of variables that influences the perception of comfort/discomfort were selected for logistic regression analysis.

The probability of window blind closing events was found to increase as the magnitude of visual and/or thermal discomfort sensation increased, which can be predicted based on the luminous and thermal environmental conditions. A total of four single variable and nine multivariate logistic models were derived for a limited range of visual and thermal conditions examined in this study.

5. The field study results showed that confounding factors such as Mean Radiant Temperature (MRT) and direct sun penetration could influence window blind control behavior. These confounding factors were integrated into the multivariable models through backward elimination and forward selection variable entry techniques.

6. The field study also confirmed the hypothesis that participants' self-reported sensitivity to brightness (L_{sen}) influences the window blind closing behavior. The participants' self-reported sensitivity to temperature (T_{sen}), however, was not found to be a statistically significant confounding factor.

7. Based on the comparison of Akaike Information Criterion (AIC) values, the model with the largest number of independent variables (Model M1) was ranked as being the best model. In this model, the window blind closing events are predicted as a function of average window luminance (L_{win}), maximum window luminance (L_{mxwin}), vertical solar radiation at window (SOL) and participants' brightness sensitivity (L_{sen}).

8. A comparison between standard and longitudinal techniques showed that the regression coefficients from the two techniques are comparable for the majority of regression and logistic regression models. The longitudinal techniques, however, provided different estimates for a few discomfort glare predictor variables such as average window luminance (L_{win}) and vertical solar radiation at window (SOL).

CHAPTER 5

DISCUSSION

This study investigated how and why building occupants control window blinds in private offices. The objectives of this study were to: explain building occupants' pattern of window blind usage with the emphasis on window blind closing behavior, determine whether variation in lighting and thermal environment influences the control behavior, and determine whether contextual factors and individual preferences influence the control behavior.

Data from the window blind usage survey and field study were collected from participants who occupied offices with Venetian blinds in Berkeley, California between September 2004 and February 2005. These data supported the research hypothesis that the probability of a window blind closing event is a function of physical environmental conditions that are related to the occupants' perception of indoor comfort.

In this dissertation, many predictive window blind control models were derived as a function of interior luminance characteristics, transmitted vertical solar radiation, temperature and direct solar penetration. In these models, the probability of window blind closing event was found to increase as the magnitude of visual and thermal discomfort sensations increase. These subjective visual and thermal discomfort sensations were found to correlate with the monitored physical environmental conditions. In addition, the field study data suggested that the internal psychological factor, the participants' self-reported brightness sensitivity, influence the window blind control behavior.

This chapter can be divided into four major sections. First, the chapter discusses the derived models with respect to model selection and model interpretation. Second, the similarities and differences between derived and existing window blind control models are discussed in the context of the implementation of window blind control models in energy simulation programs and in future automated blind systems. Third, this chapter examines the integration of physical and non-physical factors in the window blind control model. Lastly, this chapter discusses results from the visual comfort assessment.

5.1 Examination of window blind control models

5.1.1 Window blind control model selection

A total of 4 single variable and 9 multivariate window blind control models were derived in the current study. When there is more than one model to choose from, architects, engineers, and researchers often seek guidance in choosing an appropriate model for the automated window blind systems and energy simulation programs; The model selection process is discussed in this section.

Forster (2000) suggested that the underlying concept for all of the model selection methods is based on Occam's razor which states that one should not make more assumptions than needed. When multiple explanations are available for a phenomenon, the simplest version is preferred.

Occam's razor is reflected in the model-building principle of parsimony, which states that models should have no more parameters than are necessary to adequately represent the relationships. One reason for this is that simple models are easier to understand and interpret than complex models. Another reason is that the standard errors

(SE) of the regression coefficient tend to inflate when a model contains unnecessary variables. The inflation of standard errors could influence the precision of estimates (Agresti & Finlay, 1997). As a consequence, researchers usually make a compromise between a model's bias and variance (i.e. uncertainty) versus the number of estimated parameters in the model (Burnham and Anderson, 2002). A model with too many variables will have low precision whereas a model with too few variables will be biased.

In this study, the variables in the models were carefully selected to ensure that they correlate with subjective comfort sensations. Additional attention was given to decreasing the multicollinearity between variables. The models were derived through stepwise regression techniques (i.e. backward elimination and forward selection) and were validated by the likelihood ratio test or by Wald statistics. The null hypothesis was rejected if the p -value of the parameter and the model were less than .05.

5.1.1.1 Model selection criteria

The criteria that were used to compare and select models are described below.

1. Nagelkerke's r^2

Traditionally, the Pearson correlation coefficient (r) and the coefficient of determination (r^2) are used to describe the strength of association for relationships in standard least square regression. For logistic regression, a number of logistic R^2 measures have been proposed. This study reported Nagelkerke's r^2 , which is a further modification of the Cox and Snell coefficient to assure that the r^2 value varies from 0 to 1 (Nagelkerke, 1991). It should be noted that Nagelkerke's r^2 is not a goodness-of-fit test but rather an attempt to measure strength of association.

2. Percentage of correct prediction

Another approach to evaluate the model is to compare predicted group membership with observed group membership (Pampel, 2000). The correct and incorrect estimates are tallied from the 2 x 2 classification table. Using Model L2 as an example, an example of a classification table is shown in Table 5.1. In this table, the columns are the two predicted values while the rows are the two observed values of the dependent variables. For a perfect model, the percentage of correct predictions will be 100%. A failed model would do no better than chance, by correctly predicting 50% percent of the cases.

Table 5.1 Classification Table for Model L2

		Predicted		
		CLOSE		Percentage Correct (%)
Observed CLOSE	0	0	1	
	1	6	14	30.0
Overall Percentage		6	47	88.7
				72.6

3. Akaike's Information Criterion (AIC)

The coefficient of determination (r^2) was not included as a part of the output from the Generalized Estimating Equation technique. On the contrary, the Akaike's Information Criterion (AIC) value, a statistical model fit measure, can be estimated for each logistic model. Therefore, this study proposed to rank logistic models based on Akaike's Information Criterion (Akaike, 1973; Sakamoto, Ishiguro, & Kitagawa, 1986).

The Akaike's Information Criterion (AIC) value for each model was calculated from the log likelihood value from standard logistic regression analysis.

The AIC is defined as:

$$AIC = -2L + 2p \quad (5.1)$$

where

L Log likelihood value

p Number of parameter estimates in the model

Previous research (Forster, 2000; Miller, 2002) suggested that there are three advantages of using AIC instead of the classical hypothesis testing in model selection. First, the AIC can be applied to nested and non-nested models, whereas the classical hypothesis testing method does not extend straightforwardly to non-nested hypotheses. Second, the AIC effectively trades type I for type II errors where as the classical hypothesis testing methods trade goodness-of-fit for simplicity. Finally, the AIC can be applied in situations in which normality is not assumed, in which case the maximum likelihood fitting procedure may not be equivalent to least squares fitting.

In this study, the models were evaluated by three AIC-related values.

3.1 Direct comparison of AIC values. In itself, the value of the AIC for a given data set has no meaning. However, when the AIC value from one model is compared to a set of other models' AIC, the model with the lowest AIC is considered to be the "best" within a particular set (Hardin & Hilbe, 2003).

3.2 Delta AIC (Δ_i). Comparison of models can also be conducted with the delta AIC (Δ_i) which is a measure of each model relative to the best model (Burnham & Anderson, 2001). The delta AIC is calculated from the following equation:

$$\Delta_i = AIC_i - AIC_{\min} \quad (5.2)$$

The AIC_i is the AIC value for model i and AIC_{\min} is the AIC value of the best model. The Δ_i values are easy to interpret and allow a quick strength of evidence comparison and ranking of candidate models. The larger the Δ_i , the less plausible that fitted model i as being the best approximate model in the candidate set (Burnham & Anderson, 2001). As a general rule, models having $\Delta_i < 2$ have substantial support, those where $3 < \Delta_i < 7$ have considerably less support, while models having $\Delta_i > 10$ have essentially no support.

3.3 Akaike Weight (w_i). The measure of strength of evidence for each model can also be measured with the Akaike weight (w_i) which represents the ratio of Δ_i value for each model relative to the whole set of R candidate models (Burnham & Anderson, 2001). Akaike weight can be calculated from the following equation:

$$w_i = \frac{e^{(-\Delta_i / 2)}}{\sum_{r=1}^R e^{(-\Delta_r / 2)}} \quad (5.3)$$

Akaike weight (w_i) indicates the probability that the model is best among the whole set of candidate models. For example, an Akaike weight of 0.8 for a model indicates that it has a 80% chance of being the best model among a set of candidate models.

4. Area under the Receiver Operating Characteristic (ROC) curve. Based on the signal detection theory, this method was proposed by Swets (1988) to measure the accuracy of diagnostic systems. This method has been used in psychology and recently applied to other fields such as medical science and nutrition science.

Basically, this method uses information from the classification table. Because hits and misses are complementary events, as are correct rejections and false alarms, the window blind closing event can be expressed as a function of two independent responses rate: the probability of hit and the probability of false alarm. Such a curve is called a Receiver Operating Characteristic (ROC), in which the probabilities vary from 0 to 1 (see Figure 5.1). Table 5.2 describes the classification of model's accuracy based on the area under the ROC curve (Tape, n.d.).

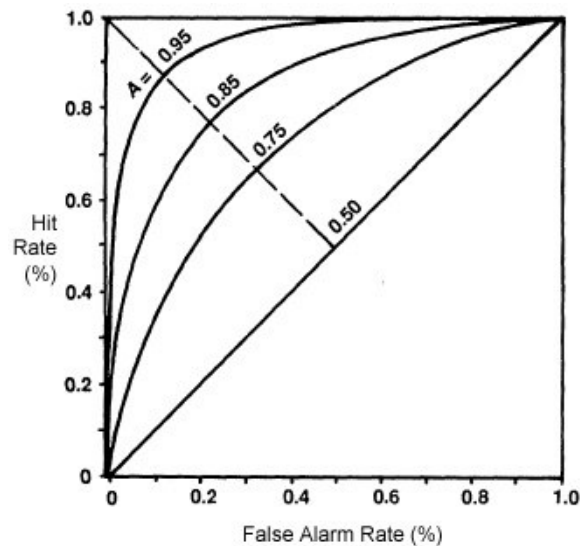

Figure 5.1 Idealized ROC Curves with the corresponding value of area under the ROC curve.

Table 5.2 Classification of Model's Accuracy Rating Based on the Area under the ROC Curve (Tape, 2005)

Area under ROC Curve	Rating
0.90-1	Excellent
0.80-0.90	Good
0.70-0.80	Fair
0.60-0.70	Poor
0.50-0.60	Fail

5.1.1.2 Model selection findings

Table 5.3 describes the AIC-related values, Nagelkerke R^2 , and percentage of correct predictions of the derived models. In addition, the area under the Receiver Operating Characteristics (ROC) and Standard Error (SE) are also given for each variable. The models are ranked based on the AIC value.

Data in Table 5.3 shows that the R^2 range from 0.30-0.69. The models derived in this study correctly predicted between 73-90% and the area under the ROC curve ranges between 0.80-0.95.

As expected, Model M1, which has four independent variables, has the lowest AIC (48.24), the highest R^2 (0.69), the highest percentage of correct predictions (89%) and has the largest area under the ROC curve (0.95). When ranked by AIC value, all four single variable models were in the bottom five. Model M9 was the only multivariate model that was ranked in the bottom five, below two other single variable models.

Overall, the AIC, R^2 , percentage of correct prediction, and area under ROC similarly rank the models with the exception of Model L2. Based on AIC alone, Model L2 was ranked above three other models which have higher R^2 , percentage of correct predictions and area under the ROC values. Further examination of the AIC calculation helps explain this disagreement.

Table 5.3 Summary of Model Selection Criteria

No.	Variable	AIC	Δ_i	w_i	R^2	% Correct	ROC Area	Coeff.	SE	z
M1	L_{win}	48.24	-	-	0.69	89.0	0.95	-5.82	1.75	-3.32
	L_{mxwin}							6.20	2.24	2.77
	SOL							3.29	0.80	4.09
	L_{sen}							1.22	0.36	3.37
M2	SOL	50.83	2.59	0.99	0.62	86.3	0.92	3.22	0.92	3.50
	L_{sen}							1.22	0.50	2.40
M3	L_{mxwin}	61.31	13.07	0.01	0.53	84.0	0.89	4.87	1.08	4.48
	MRT							0.25	0.12	2.04
M4	L_{mxwin}	62.21	13.97	0.00	0.57	84.3	0.89	4.76	0.98	4.84
	L_{sen}							0.72	0.24	2.98
M5	L_{glo1}	66.18	17.94	0.00	0.53	84.3	0.88	5.31	1.56	3.41
	L_{sen}							0.86	0.25	3.44
M6	L_{win}	68.81	20.57	0.00	0.52	86.7	0.88	2.44	1.05	2.31
	$Disun$							1.89	0.93	2.03
	L_{sen}							0.79	0.31	2.56
M7	L_{win}	70.96	22.72	0.00	0.40	77.3	0.84	4.51	1.18	3.80
	MRT							0.23	0.12	1.97
M8	L_{win}	71.44	23.2	0.00	0.47	84.3	0.86	3.77	0.89	4.22
	L_{sen}							0.68	0.26	2.63
L1	L_{mxwin}	71.5	23.26	0.00	0.44	80.7	0.86	4.69	0.87	5.35
L2	SOL	73.02	24.78	0.00	0.30	72.6	0.78	2.59	0.54	4.76
M9	L_{win}	80.15	31.91	0.00	0.36	73.5	0.82	3.33	1.11	3.01
	$Disun$							1.28	0.65	1.97
L3	L_{glo}	80.6	32.36	0.00	0.33	78.3	0.80	4.95	1.24	3.97
L4	L_{win}	80.82	32.58	0.00	0.33	73.5	0.80	4.36	0.90	4.81

The AIC value is calculated as a function of the maximum likelihood value (or the residual sum of squares), the sample size, and the number of parameters in the model. The AIC value for a model that has a high SE value (less precise) will tend to be higher than for those that have smaller SE values (more precise). An examination of the SE showed that Model L2 has the lowest SE value of the single variable models. Therefore, the AIC value of Model L2 was found to be smaller than the values of other single variable models. Thus, Model L2 was ranked above other models.

Examination of the Akaike weight showed that Model M2 has 99% chance of becoming the best model (compared with Model M1). Models that are ranked below Model M2 have no substantial support to be the best model (<1% chance).

Consideration of the area under the ROC curve for each model showed that Models M1 and M2 were rated as excellent. All other models were rated as good.

5.1.1.3 Selection of the best model

Based on the different evaluation criteria, this study suggests that window blind control models can predict blind closing events with varying degree of accuracy. To answer the question of which model is the best, the difference between explanatory and exploratory modes of model selection must be understood.

In exploratory research, the goal is simply to find a good set of predictors (Agresti & Finlay, 1997). On the other hand, in explanatory research, theory determines which variables are in the model in explanatory research. This dissertation was designed to be both exploratory and explanatory.

As exploratory research, a total of 13 logistic models were derived. Using the evaluative criteria described in section 5.1.1.1, the best model consists of 4 independent variables.

As explanatory research, limitations from the actual implementation will determine whether the models are appropriate for use. For example, models which have the self-reported brightness sensitivity as one of the predictors may not be suitable for use in energy simulation programs but will likely be very useful in future automated blind systems.

To answer the question of the best model, researchers must understand how the model will be used and what (or how many) parameters can or cannot be provided in the model. For example, while the model with four predictor variables (Model M1) is considered to be the best, the computational process in an actual automated window blind control algorithm may be expensive and time-consuming. The second best (Model M2), which consists of only two variables, could be substituted. The two-variable models will likely to take less computational time while providing a comparably high percentage of correct predictions. Alternatively, if the interaction effect of window brightness and temperature needs to be examined, model M8 should be used. Finally, researchers and manufacturers may consider using models with only one variable, which will be very easy to implement in current automated window blind control systems and energy simulation programs.

It should be noted that the model selection criteria in this study were calculated from standard logistic regression because the output from the Generalized Estimating Equation (GEE) technique does not include any criterion for the measurement of strength

or accuracy of the model other than the Wald statistics. Because the regression coefficients and Standard Errors (SE) between standard logistic and longitudinal regression techniques were comparable (Tables 4.16 and 4.18), this study proceeded on the assumption that the criterion measures calculated from the standard logistic regression can be used as substitutes for the criterion measures as if they were computed from the longitudinal regression technique.

5.1.2 Interpretation of logistic regression coefficients

The effects of the independent variables in logistic regression have multiple interpretations. This section discusses interpretations of logistic regression coefficients in terms of odds, probabilities and threshold value.

5.1.2.1 Odds

The odds is the ratio of the probability that an event will occur over the probability that the same event will not occur (Kleinbaum & Klien, 2002). The odds can be expressed by the following equation:

$$\text{Odds} = P(X) / [1-P(X)] \quad (5.4)$$

where $P(X)$ denotes the probability of the event of interest, which is equal to the logistic model as defined in Equation 3.24.

The interpretation of odds comes from transforming the logistic regression coefficients by taking the exponent or antilogarithm of the logistic regression coefficients and predictor variables.

Using Model M9 as an example, the odds of closing window blinds can be calculated if the window luminance level and direct solar penetration are specified. For example, a researcher might want to compare the odds between two conditions: when direct sun is present and when direct sun is not present at the average window luminance of 1000 cd/m² ($L_{win} = 3 \text{ log-cd/m}^2$). The odds for two conditions can be calculated by taking the exponent of the logistics regression coefficients ($\alpha = -9.94$, $\beta_1 = 3.33$, $\beta_2 = 1.28$) in model M9 through the following steps:

1. Write the model in logit form

$$\text{Logit (no sun)} = \alpha + \beta_1 L_{win} + \beta_2 \text{Disun} = -9.94 + 3.33(3) + 1.28(0) = 0.05$$

$$\text{Logit (sun)} = \alpha + \beta_1 L_{win} + \beta_2 \text{Disun} = -9.94 + 3.33(3) + 1.28(1) = 1.33$$

2. Take the exponential of the logit value, which is equal to the odds

$$\text{Odds}_{\text{no sun}} = e^{0.05} = 1.05$$

$$\text{Odds}_{\text{sun}} = e^{1.33} = 3.78$$

Because the odds have multiplicative rather than additive affects, this example shows that the presence of direct sun penetration increases the odds of closing blinds by a factor of 3.6 (which equals to $\text{Odds}_{\text{sun}}/\text{Odds}_{\text{nosun}}$ or the exponent of the regression coefficient for direct solar penetration ($e^{1.28}$).

An equivalent explanation is that the regression coefficient (β_i) represents the change in log odds that would result from a one-unit change in the variable i when other variables are fixed. By definition, a logit is a log odds, so that the difference between two

logits is the same as the difference between two log odds. The interpretation of log odds is particularly useful if one would want to summarize the odds of an event for a categorical variable such as direct solar penetration. This study found that when the direct sun is present, the chance of closing the blinds is 3.6 times higher than when there is no direct sun.

5.1.2.2 Probabilities

The second interpretation of the logistic model involves translating log odds or odds to probabilities. Since the relationships between independent variables and probabilities are non-linear and non-additive, they cannot be fully represented by a single coefficient (Pampel, 2000). The effects on probability have to be identified at a particular value (of an independent variable) or a set of values. The choice of values depends on the concerns of the researcher and the nature of data.

Using Model L2 ($\alpha = -2.89$, $\beta = 2.59$) as an example, researchers might want to examine the probability of window blind closing between two low and high vertical solar radiation values (e.g. 10 and 100 W/m² or 1 and 2 log-W/m²). The probability of window blind closing can be calculated by:

1. Writing the model in logit form

$$\text{logit}(X) = -2.89 + 2.59(SOL)$$

2. Converting the logit to odds

$$\text{Odds}(SOL_{\text{low}}) = e^{[-2.89 + 2.59(1)]} = 0.74$$

$$\text{Odds}(SOL_{\text{high}}) = e^{[-2.89 + 2.59(2)]} = 9.87$$

3. Calculating the probability from odds with the following equation:

$$P(X) = \text{odds}/(1 + \text{odds})$$

$$P(\text{Close}_{\text{low}}) = 0.74/(1 + 0.74) = 0.42$$

$$P(\text{Close}_{\text{high}}) = 9.87/(1 + 9.87) = 0.90$$

From the calculation above, at the vertical solar radiation value of 10 W/m^2 there is a probability of 0.42 that the window blind will be closed. At the vertical solar radiation value of 100 W/m^2 , the probability of window blind closing is 0.9.

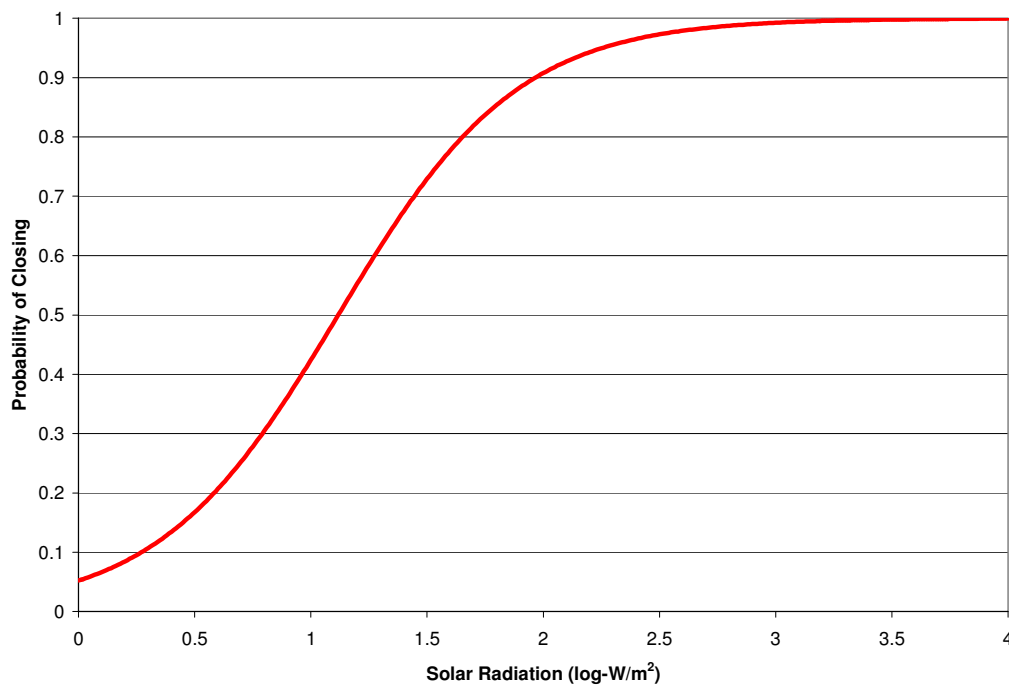

Figure 5.2 Logistic model of window blind closing events as a function of vertical solar radiation at the window.

Following this method, the probability of window blind closing can also be plotted as a function of vertical solar radiation, as shown in Figure 5.2. The logistic curve in Figure 5.2 shows that for a very low vertical solar radiation level, the probability of window blind closing is low. The data showed that the probability of window blind

closing increases as the level of vertical solar radiation increases. The probability reaches 100% at a very high vertical solar radiation level.

In this study, a few examples of window blind control models which express probability of closing as a function of predictor variables were shown in Chapter 4. By translating the regression coefficients into a probability curve, researchers can estimate a specific predictor value at a certain probability value (such as a threshold value) without complex calculations.

5.1.2.3 Threshold value

The last interpretation of the regression coefficients is threshold value. The threshold is a theoretical construct that indicates the particular stimulus value at which the binary variable goes from 0 to 1. Threshold is often defined as the stimulus value at the probability equal to 50% on the logistic function.

The threshold value for each window blind control model was defined as the value at which the probability function is equal to 50%. Estimated threshold values for a few window blind control models were described in Tables 4.17 and 4.29. For example, results from Model L2 suggest that window blinds shall be closed when vertical solar radiation at the window reaches 13 W/m^2 .

In addition, because the threshold value is defined as the value at a specific probability (50%), it can be inferred that when vertical solar radiation at the window reaches 13 W/m^2 , 50% of all window blinds will be closed (i.e. the average window blind occlusion value equal 50).

5.2 Comparison of model predictions with actual window blind occlusion data

To validate one of the derived window blind control models (Model L2), the window blind occlusion from the model was estimated and compared with the average window blind occlusion values from an actual building. Window blind occlusion data were gathered during the pilot study phase of this study, in which window blind operations were observed for a period of 9 days from September 24 to October 4, 2002 (weekends excluded). In this pilot study, the north, east, and south façades of an office building in Berkeley, California (Latitude 38°N) were digitally photographed four times each day at 9:00, 13:00, 16:00, and 18:00 (see Figures 5.3).

Figure 5.4 shows the window blind position categories from 0 (fully open) to 10 (fully closed) that was used during the pilot study. In total, the window blind positions of approximately 9,700 windows were identified through analysis of time-lapse digital photography. The average occlusion value for each façade orientation was calculated by averaging the window blind position for all windows in each façade at the time that the picture was taken.

Figure 5.5 summarizes the average window blind occlusion for three façade orientations. The photographs revealed two major window blind control characteristics. First, the window blind occlusion level changed only slightly on a day-to-day basis. Second, the photographic data showed that the average window blind occlusion values were greatly different between the north and the two other façade orientations. The average occlusion value for the north façade was approximately 53 while the value for the east and south façades was approximately 80.



North Façade

South Façade



East Façade

Figure 5.3 North, east, and south façades of the building that was monitored during the pilot study.

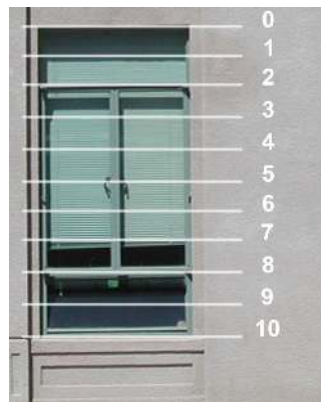

Figure 5.4 Categories used in identifying window blind positions during the pilot study.

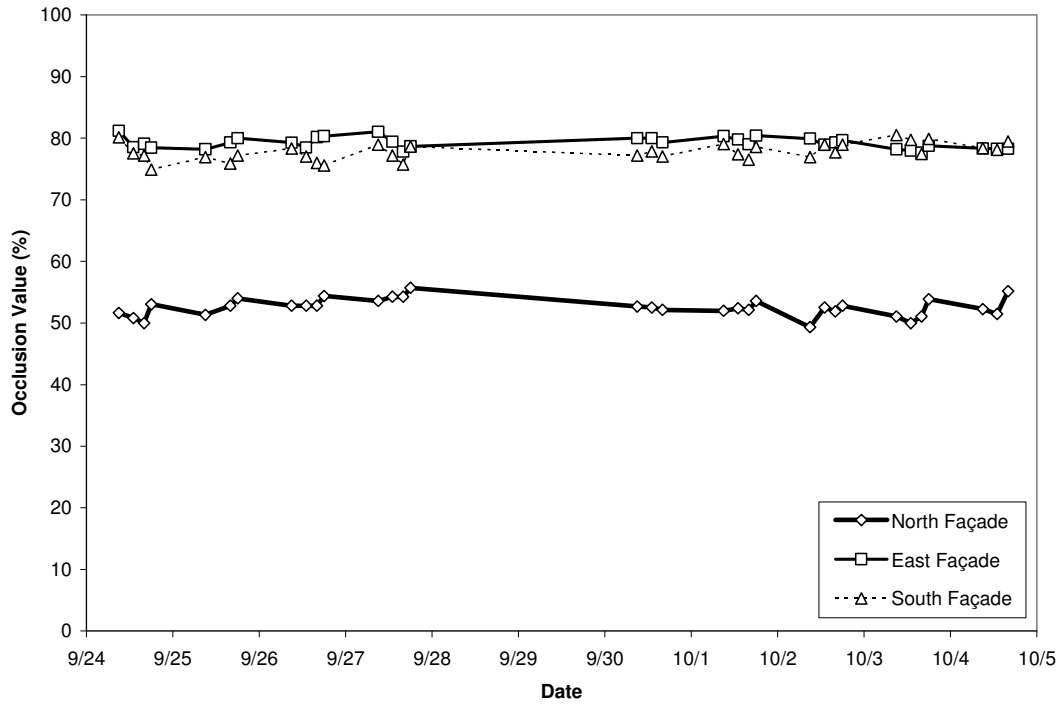

Figure 5.5 Average window blind occlusion value of three façade orientations.

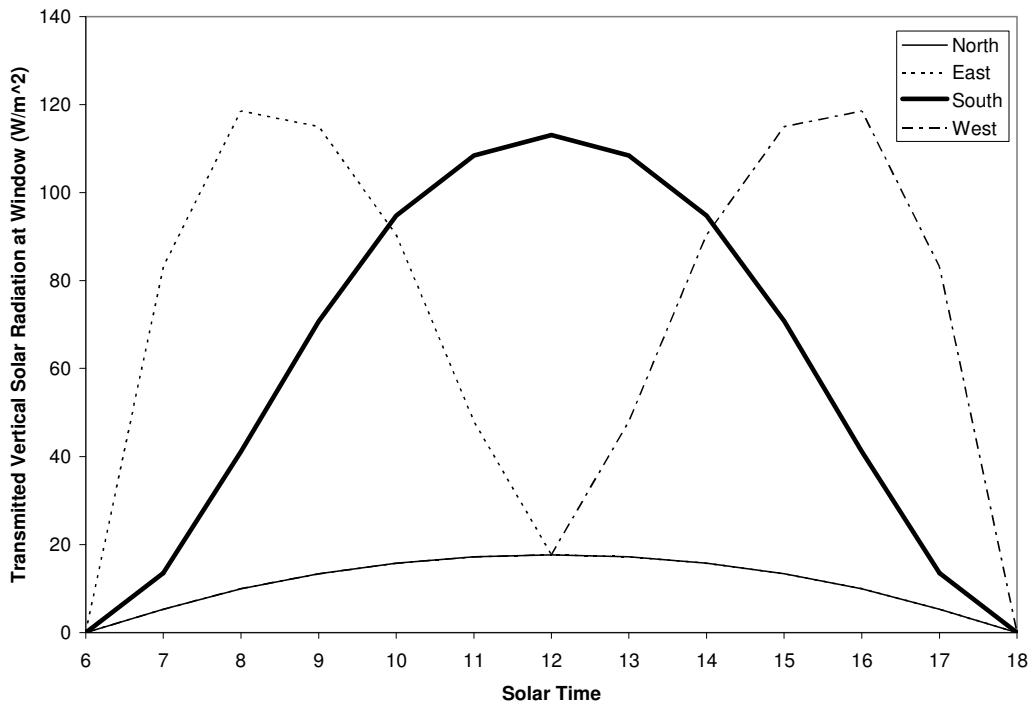

Figure 5.6 Calculated total transmitted vertical solar radiation at window for a building in Berkeley, CA (Latitude 38°N) on September 21 (Equinox condition).

The next step in the model comparison was to calculate the probability of window blind closing using the maximum transmitted vertical solar radiation (by assuming that building occupants will adjust their window blinds according to the worst case scenario).

Assuming that the building glass has a vertical solar transmission value of 0.5, the total transmitted vertical solar radiation for a typical building in Berkeley, CA on September 21 was calculated and shown in Figure 5.6. The maximum transmitted vertical solar radiation for north, east and south façades are 17, 118 and 113 W/m², respectively.

Using the calculation method described in section 5.1.2.3, the probability of window blind closing for the north, east, and south façades were found to be 0.57, 0.92, and 0.91, respectively, which are equal to the average occlusion values of 57, 92, and 91, respectively.

This study found that the predicted average occlusion value for the north façade was comparable to the actual value. However, the predicted value for the south and east façade were found to be 10 points higher than the actual value. Further analysis of the field study helps to explain the differences.

First, the case study building was naturally ventilated, in which the lower portion of the window swings inward to allow cross ventilation (Figure 5.7). On the south and east façades, the majority of window blinds were found to be lowered to the top of the hopper window (position #8). If the window blinds are lowered below this position, they create a rattling noise. Because the windows in this building were generally open as a means for cooling (Brager, Paliaga, & De Dear, 2004; Inkarojrit & Paliaga, 2004), this resulted in the average occlusion value of 80.

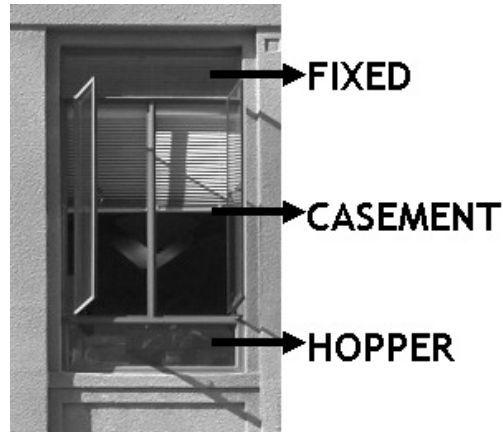

Figure 5.7 Configuration of a typical window in the pilot study.

Second, any predictive model is rarely a perfect representation. In the example window blind control model (Model L2), it was anticipated that the model would correctly predict 72% of actual behavior. Twelve points difference between predicted and actual average occlusion value could be due to this error term.

Taking these two factors into consideration, the predicted and estimated window blind occlusion values are considered to be comparable. It is concluded that the window blind control models can be used to predict how building occupants control window blinds in real office buildings.

5.3 Comparison of average occlusion value between empirical models

This section compares the predicted average occlusion values between two empirical window blind control models, the derived model and the Reinhart's model (Reinhart, 2001).

Because data collection procedures between two studies were different, direct comparison of all predicted values between models was not available. However, by using a vertical solar radiation at window value that was specified in Reinhart's model

(50 W/m^2) as an input, the average window blind occlusion between different models could be compared.

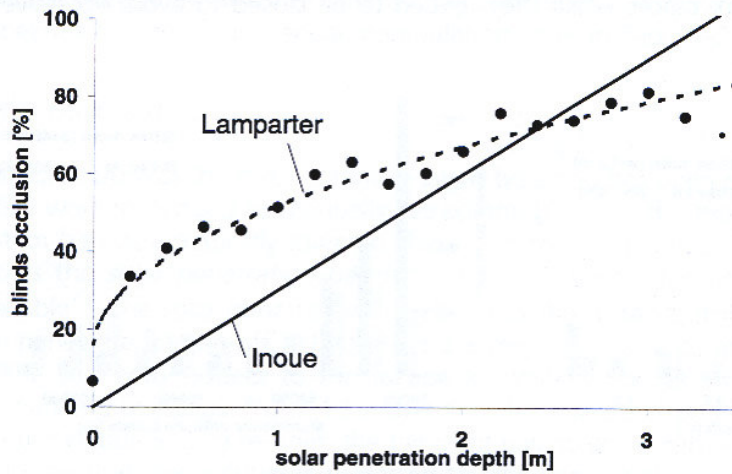

Figure 5.8 Average window blind occlusion for different solar penetration depths for the occupied time when the solar radiation at window was above 50 W/m^2 (after Reinhart, 2001, p. 82).

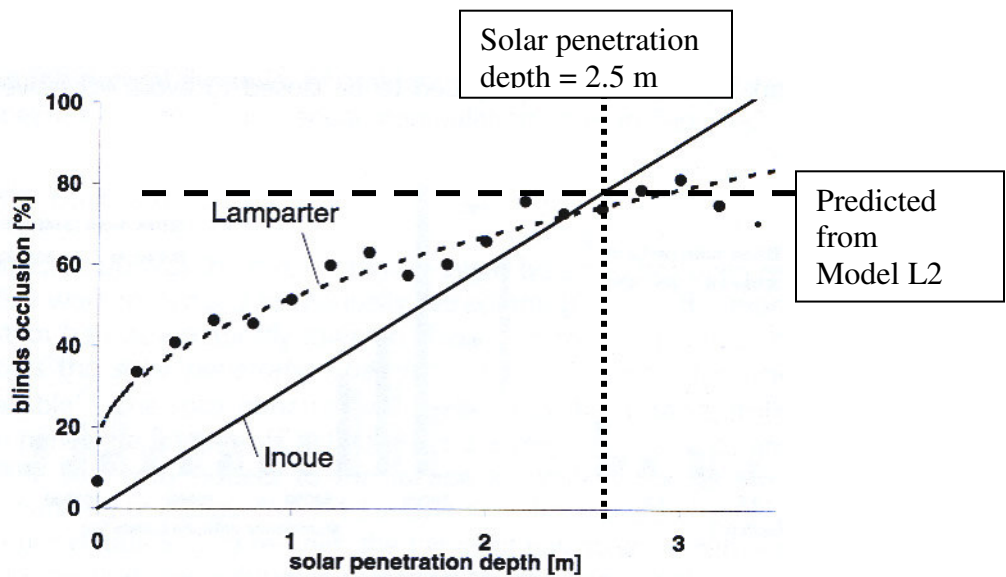

Figure 5.9 Average window blind occlusion prediction from Model L2 for vertical solar radiation at window of 50 W/m^2 .

Figure 5.8 showed the average window blind occlusion for different solar penetration depths from the Inoue et al. (1988) and Lamparter (Reinhart, 2001) studies.

Data in this figure showed that the average window blind occlusion increases as the solar penetration depth increases (at a fixed vertical solar radiation value of 50 W/m^2).

To compare predicted values, two pieces of information, the probability of closing the window blinds at 50 W/m^2 and the solar penetration depth during the data collection, were gathered. First, from Model L2 (Figure 5.2), the probability of closing a window blind is 0.8, which is equal to the average window occlusion value of 80. Second, because the data in this study were collected between September and February, the solar penetration depth was 2.5 m and higher (for east, south, and west façades). The level of probability and the solar penetration depth were overlaid on Figure 5.8 for comparison (see Figure 5.9).

The results showed that the predicted average occlusion values between derived and existing empirical models were comparable for a specific vertical solar radiation and solar penetration depth. Occlusion values from the derived model and from Reinhart's model were 80 and 75, respectively.

5.4 Implication in energy simulation programs: Comparison between existing and derived models

In the simulation of building performance, operable shading devices such as window blinds and shades, which are used by the building occupants to control daylight, sunlight and glare, can significantly impact the thermal, visual, and energy performance of buildings. Therefore, one of the goals of this study was to develop predictive manual control algorithms that can be used as a function in energy simulation programs.

The implementation of derived window blind control models is discussed in the context of two of the most widely used energy simulation programs: DOE-2 and EnergyPlus. The advantage of using DOE-2 and EnergyPlus in simulating commercial building energy performance is that researchers can incorporate the operation of window shading devices in the building simulation process. The discussion is divided into four parts. First, an overview of building energy calculation with DOE-2 and EnergyPlus is described. Second, a few examples of existing window blind control algorithms are reviewed. Third, the derived window blind control algorithms are described in terms of their input and output variables. Finally, a short hypothetical example will be given to demonstrate how the model can be used by architects and engineers to predict and compare engineering performance of commercial buildings with different glazing types and blind control strategies.

5.4.1 Overview of building energy simulation with DOE-2 & EnergyPlus

DOE-2 and EnergyPlus calculate building sensible and latent loads, and simulate HVAC systems and plant behavior for whole building thermal analysis. Thermal comfort indices can be calculated based on activity, dry bulb temperature, humidity and solar radiation. Advanced features such as operable window shades and electrochromic glazing can be included in the simulation.

In addition to thermal performance analysis, DOE-2 and EnergyPlus can also perform daylighting analysis. The daylighting analysis in these programs has three key stages. First, a pre-processor calculates a set of “daylight factors” for a grid of

standardized sun positions and sky conditions (clear and overcast). Secondly, an hourly daylight and glare calculation is performed to determine interior illuminance at a defined reference point. Lastly, either stepped or continuous dimming control of the electric lighting systems is simulated to calculate both electric lighting savings and the thermal impact of reduced lighting loads. In the future, the daylighting module will include an improved interior interreflection calculation and handling of complex fenestration systems such as blinds, lightshelves, roof monitors, etc. (Crawley et al., 2001).

5.4.2 Modeling window blind usage in DOE-2 and EnergyPlus

Basically, window blinds in DOE-2 and EnergyPlus can be controlled by three methods;

- 1. Scheduled Controls** - Fixed time schedules dictate when a shade is open or closed.
- 2. Threshold Controls** – Shades open or close depending on the conditions during the simulation
- 3. Probabilistic Control** - There is a probability that occupants respond correctly to conditions in the building (thresholds) and open or close shades accordingly.

Window systems in DOE-2 and EnergyPlus can have shading devices such as blinds, pull-down shades, or drapes. Currently, these shading devices are assumed to have perfectly diffused surfaces with optical properties independent of the angle of

incidence. Shades are entered in the simulation program as a separate interior or exterior layer characterized by solar and visible transmittance and front and back reflectance.

Shades can be fixed or movable. Movable shades can be controlled by specifying a schedule. In addition, the shade can be controlled to deploy if the trigger variable exceeds the set point. Allowed trigger variables (predictor variables) include:

1. Solar radiation incident on the window
2. Total horizontal solar radiation
3. Outside air temperature
4. Previous time-step room air temperature or cooling load.
5. Daylight glare index

The window blind control model is incorporated into the daylighting module of EnergyPlus (see Figure 5.10). At the outermost level, the simulation manager controls the interactions between all simulation loops from a sub-hour level up through the user selected simulation period. EnergyPlus uses a heat balance model for calculating building thermal zones. The fundamental assumption of heat balance models is that air in each thermal zone can be modeled as well-stirred with uniform temperature throughout (Crawley et al., 2001).

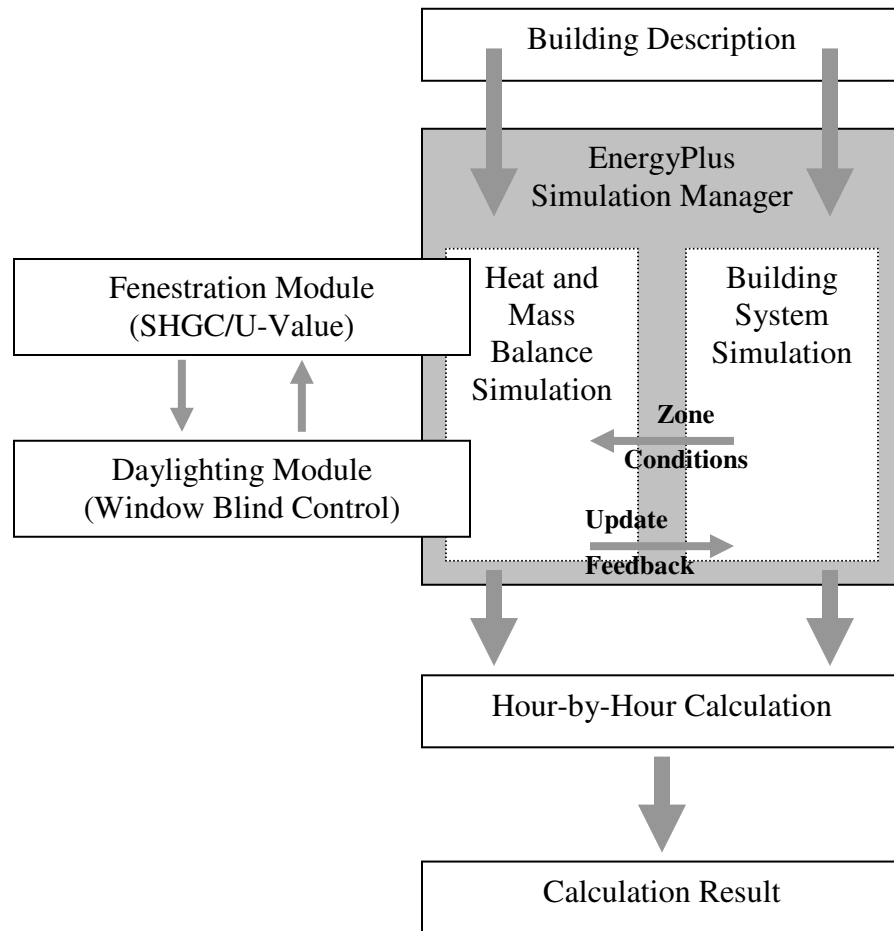

Figure 5.10 Simplified diagram of the EnergyPlus program structure (after Crawley et al., 2001).

The daylighting model, which handles complex fenestration systems, calculates electric lighting reduction for the heat balance module by estimated daylight illuminance for different blind positions and controls electric lighting accordingly. The property of window blinds at different positions can be retrieved from the fenestration module.

After the heat balance manager completes simulation for a time step, it calls the building system simulation manager, which controls the simulation of HVAC and electrical systems, equipment and components, and updates the zone-air conditions. Finally, output data such as annual cooling energy and lighting energy used are saved for subsequent reference and comparison.

5.4.3 Existing window blind control algorithms

A few examples of previous blind and shade control algorithms used in previous DOE-2 calculations and other independent simulation studies were summarized in section 2.3.4.

In summary, solar radiation incident on the window and daylight glare index were the most popular trigger variables in previous simulation studies. However, the threshold values were found to vary between studies. It was found that blinds and shades were lowered under the following conditions or objectives:

1. If vertical solar radiation through fenestration system exceeds predefined threshold values. This value ranges from 50 to 233 W/m².

2. If daylight glare index (DGI) exceeds predefined threshold values of 20 (Just acceptable) or 22 (Just uncomfortable).

3. To optimize workplane illuminance, to block direct sun, to control glare and to reduce thermal discomfort due to solar radiation, and to maximize louver openness. In this strategy, window blinds were controlled to maintain a stable workplane illuminance between 500 - 700 lux. This strategy involves window blind slat angle adjustment.

The literature offers little direct guidance on the issue of opening operation. While the blind opening mechanism was not specified in the first two examples, blinds and shades in the third example are assumed to be retracted once a day in the morning upon the building occupant's arrival.

5.4.4 Contribution to the building energy simulation

This study makes three major contributions to the building energy simulation.

1. The window blind control models were derived from empirical study. It is anticipated that by using the values from derived models, the window blind control behavior will be represented more accurately.

2. In addition to the threshold value, the window blind control rule can be expressed as a probability function. Using Model L2 as an example, all window blinds could be closed when the vertical solar radiation exceeds 15 W/m^2 . However, instead of closing all the window blinds, a researcher can specify, based on the probability function, that when the solar radiation exceeds 15 W/m^2 , only half of the window blinds are closed.

3. There are many alternative models to choose from in addition to those based only on solar radiation. As mentioned earlier, the percentage of correct predictions increases as the number of parameters in the model increases. Researchers may consider using models with more than one predictor variable to increase the simulation accuracy.

4. If the distribution of occupants' self-reported sensitivity to brightness is known, then differential control of blinds can be simulated, leading to more accurate prediction of energy usage.

5.5 Implementation of control models as the basis for future automated window blind systems

The major goal in this study was to provide a basis for the development of future automated shading systems that respond to the users' satisfaction and preferences. Through analysis, it can be seen that this goal can be realized by using the threshold values or probability functions that were derived from various window blind control models.

Existing automated window blind systems are controlled by simple control rules such as time of day or direct solar penetration. The threshold values in this study were derived from luminance, solar radiation, and temperature. This enables the window blinds to be adjusted according to changing environmental and climatic variations. The control rules can also be applied to workspaces on the north façade, where there is no direct solar penetration.

In addition, factors such as temperature and individual sensitivity to brightness could be integrated into the model. This integration addresses the interaction effect of the visual environment, thermal environment, and building occupant, which helps the automated window blinds to be controlled more accurately.

Another example of threshold value implementation is that the threshold value can be used in the procurement specification of automated window blind systems. Procurement specification is an approach to obtaining tailored technological solutions at competitive prices. These specifications detail performance requirements for all aspects of a technology and enable manufacturers to understand the full scope of their involvement on a project. For example, one of the goals specified in the procurement

specification for an automated window shade for the new New York Times Headquarters was to maintain a glare free environment (LBNL, 2005). To achieve this goal, the threshold value for the average luminance of the unobstructed portion of the window wall was set to 2000 cd/m². This value was established based on the results from a concurrent visual comfort study at the Lawrence Berkeley National Laboratory. This threshold value was set to reflect the IES 1:10 luminance ratio between task and remote surfaces.

Another approach to provide the basis for future automated shading systems is to express window blind control as a probability function. Review of literature in the area of intelligent window blind control systems showed that many studies utilize fuzzy control systems, Genetic Algorithms, and neural networks to the reduce energy consumption (Guillemin & Morel, 2001; Kolokotsa et al. 2001; Athienitis & Tzempelikos, 2002). In these studies, window blinds were controlled based on threshold values or on optimization of one or more of the following variables: window luminance, solar radiation, illuminance level, solar position, indoor temperature, and season (Guillemin & Molteni, 2002; Kolokotsa, 2003; Assimakopoulos et al., 2004; Park et al., 2004). Unfortunately, threshold values used in previous studies, especially for the luminance predictors, were not derived from empirical studies. The prediction results from these studies may have high error terms.

Because predictors in the abovementioned studies can be expressed as a threshold value or degree of membership (in fuzzy control theory), the models derived in the current study can be easily interpreted into many usable threshold values and cumulative distribution functions (e.g. logistic functions) and probability density functions (PDF) for use in fuzzy control systems.

5.6 Summary of derived window blind control models.

Table 5.4 summarizes inputs and outputs of existing and derived window blind control models in simulation programs.

Table 5.4 Comparison of Input and Output between Existing and Derived Window Blind Models in DOE-2/EnergyPlus

Variables		Existing Blind Control Models		Derived Blind Control Models
		DOE-2 and Energy plus	Independent Research	
Types of shade/blind		Perfectly diffused shade, shade and venetian blinds	Venetian blind	Venetian blind
Schedule		Blind close: absolute threshold from solar radiation and daylight discomfort glare Blind open: calculated on hourly basis based on specific threshold value	Blind close: absolute threshold from solar radiation Blind open: scheduled control -open once a day in the morning	Blind close: Scheduled control, absolute threshold control, probabilistic control Blind open: User defined
Input Variables	Vertical Solar radiation incident on the window	Blind close/open: Absolute threshold 63 W/m ² (Choi et al., 1984) 94.5 W/m ² (Lee et al., 2002)	Blind close: 233 W/m ² (Newsham, 1996), 12-58 W/m ² (Inoue et al., 1984), 50 W/m ² (Reinhart 2001)	13 W/m ² (at $p = 0.5$) **Varying threshold value depends on model.
	Workplane Illuminance	50 < workplane Illuminance < 70 fc	-	Found to be non-significant factor
	Outside air temperature	-	-	N/A
	Previous time-step room air temperature or cooling load.	-	-	N/A
	Daylight discomfort glare	Blind close: Absolute threshold DGI = 20 (Choi et al., 1984) DGI = 22 (Lee et al., 2002) Blind open: n/a	-	Yes Using luminance-based variables instead of calculated DGI
	Thermal comfort	-	80% PPD	MRT
	Additional input variables	-	-	- direct solar penetration - Individual sensitivity to brightness (future)
Output Variables	Blind position	Fully closed or fully open	Close/Open	Close/open
	Blind slat angle	15° incremental from ±75 from the horizontal position	-	Fully closed slat (point downward)

The derived models address the limitations of previous window blind control models and extend the prediction of window blind control behavior as follows:

1. The models were derived from empirical data.

In this study, the window blind control models were derived from field study data. Cross validation of the predicted window blind behavior agreed with the data from an actual building. Therefore, the models are likely to better represent how building occupants actually control window blinds.

2. The models have capability to address variation in blind usage.

A total of 13 predictive window blind control models were derived in this study; the models with a higher number of predictor variables were found to have a higher percentage of correct predictions. The predictor variables in the models are: average window luminance, maximum window luminance, background luminance, and transmitted vertical solar radiation at window. These variables can be easily implemented in the building energy simulation programs and provide the basis of future automated window blind control systems.

In addition, the models in this study integrate temperature, direct solar penetration, and individual sensitivity to brightness as confounding factors. This extension can be used to explain the window blind usage variation between different subgroups (i.e. by façade orientation or by individual sensitivity to brightness).

3. The models utilize probabilistic control.

In addition to controlling window blinds using a schedule and/or absolute threshold, the derived models have the capability to control window blinds based on probability (probabilistic control), which allows more variation in window blind usage

prediction. Based on the probability control, the models enable the control system to assign window blind positions to be in the intermediate state between fully open and fully closed instead of a binary state (open or close) as in previous studies.

4. The models use luminance-based variables as visual comfort predictors

Correlation analysis in this study suggested that various luminance-based variables such as average window luminance, background luminance and maximum window luminance had stronger correlation to the subjective visual comfort sensation than the traditional Daylight Glare Index. Therefore, the visual comfort sensation value in the model is represented through these luminance-based variables instead of DGI.

5.7 Integration of physical and non-physical factors in the window blind control models

From the field study data, many single-variable and multivariate logistic models were derived. In these logistic models, window blind closing behavior is determined by physical (luminous and thermal) environmental factors and internal psychological factor (self-reported sensitivity to brightness).

Review of literature and survey data suggested that non-physical factors, such as the need for privacy and view preference, also influence the control of window blinds. Unfortunately, it is not possible to examine all factors at once. This results in the derived window blind control models that are primarily based on physical environmental comfort.

To further assist future researchers and behavioral scientists in examining the interaction between human and physical environment, this research proposes a structural window blind control model that integrates physical and non-physical factors. This model is based on the Signal Detection Theory's two-stage process model.

5.7.1 A conceptual decision-making model

In this study, classic psychophysical experiments, especially from the Signal Detection Theory (Green & Swet, 1966) influenced the experiment design and analysis techniques. Signal Detection Theory (SDT) approaches the subject's behavior in detecting a threshold as a form of decision making in which nearly all reasoning and decision making takes place in the presence of some uncertainty. SDT proposes that stimulus events or decision detection are based on a two-stage process: an initial sensory process followed by a decision process that operates on the output of the sensory process (see Figure 5.11).

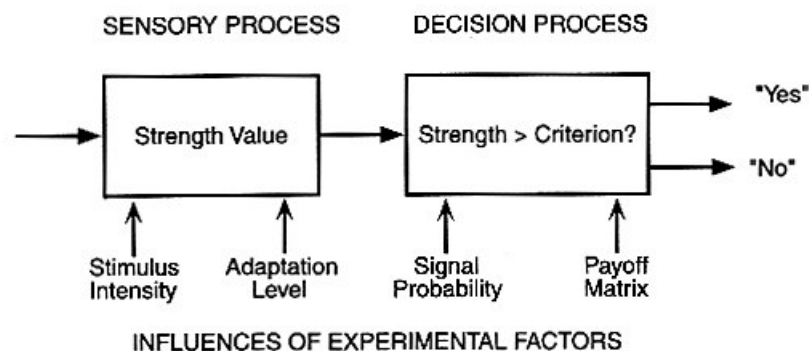

Figure 5.11 Two-stage process of Signal Detection Theory (from Palmer, 1999, p. 670).

For example in a signal detection "Yes-No" response experimental designs (Green & Swets, 1966), a respondent must make a yes-no decision as to whether a 'signal' is present on each of many independent trials. A Hit rate (the probability of 'Yes' when the signal is present) and a False Alarm rate (the probability of 'Yes' when the signal is absent) are computed.

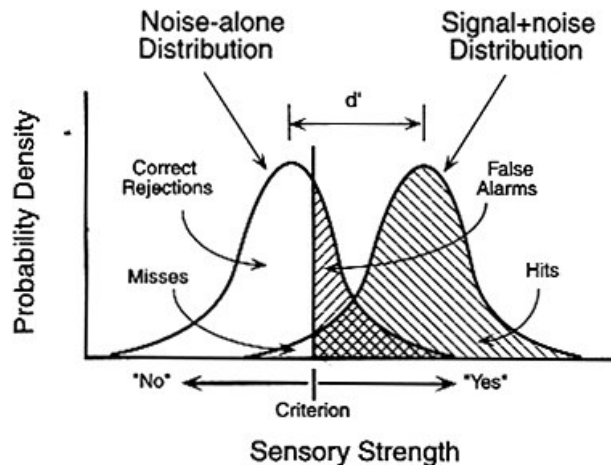

Figure 5.12 Deriving responses from signal + noise and noise-only distributions (from Palmer, 1999, p. 670).

Figure 5.12 shows response distributions from noise-only (left distribution) and signal + noise (right distribution). The horizontal axis represents the sensory strength. When a respondent has difficulty detecting the signal, the distance between the means of the distributions (d') may be small and the two distributions may overlap considerably. The Criterion indicates the minimum level of certainty that is necessary for the respondent to say 'Yes, the signal is present.' Two respondents may differ considerably in their criterion, even when they are equally sensitive (have the same d'). The signal detection model uses the relationship between Hit Rate and False Alarm Rate to estimate both sensitivity (d') and the Criterion.

5.7.2 Decision-making model based on the physical environmental criteria

Similar to the signal detection experiment, research participants in this study were presented with stimulus such as brightness, temperature, and direct sun, by opening window blind at their workspaces to a fully opened position. After exposure to the stimulus, participants were asked to respond whether they want to close the window blinds (yes = 1, no = 0). If they responded that they prefer to close their window blinds, participants were also asked to state their window blind closing reason(s). The data were summed up for each condition and analyzed with dichotomous logistic regression. The probability of a window blind closing event was then plotted as a function of stimulus intensity which was found to represent the participants' perception of visual and thermal discomfort. Ultimately, the threshold value for various stimuli, the stimulus intensity at which the average participant decides to close the window blind 50% of the time, was derived from a logistic function.

5.7.3 Integration of physical and non-physical criteria

The window blind control models derived in this study are based primarily on the physical as well as the internal psychological criteria. The apparent disadvantage of the derived models lies on the lack of the integration between all possible factors (physical and non-physical) that influence the control of window blinds.

To overcome this disadvantage, this study proposes that window blind control behaviors can be modeled based on the two-stage process model of SDT in which the experiment in this study was designed after.

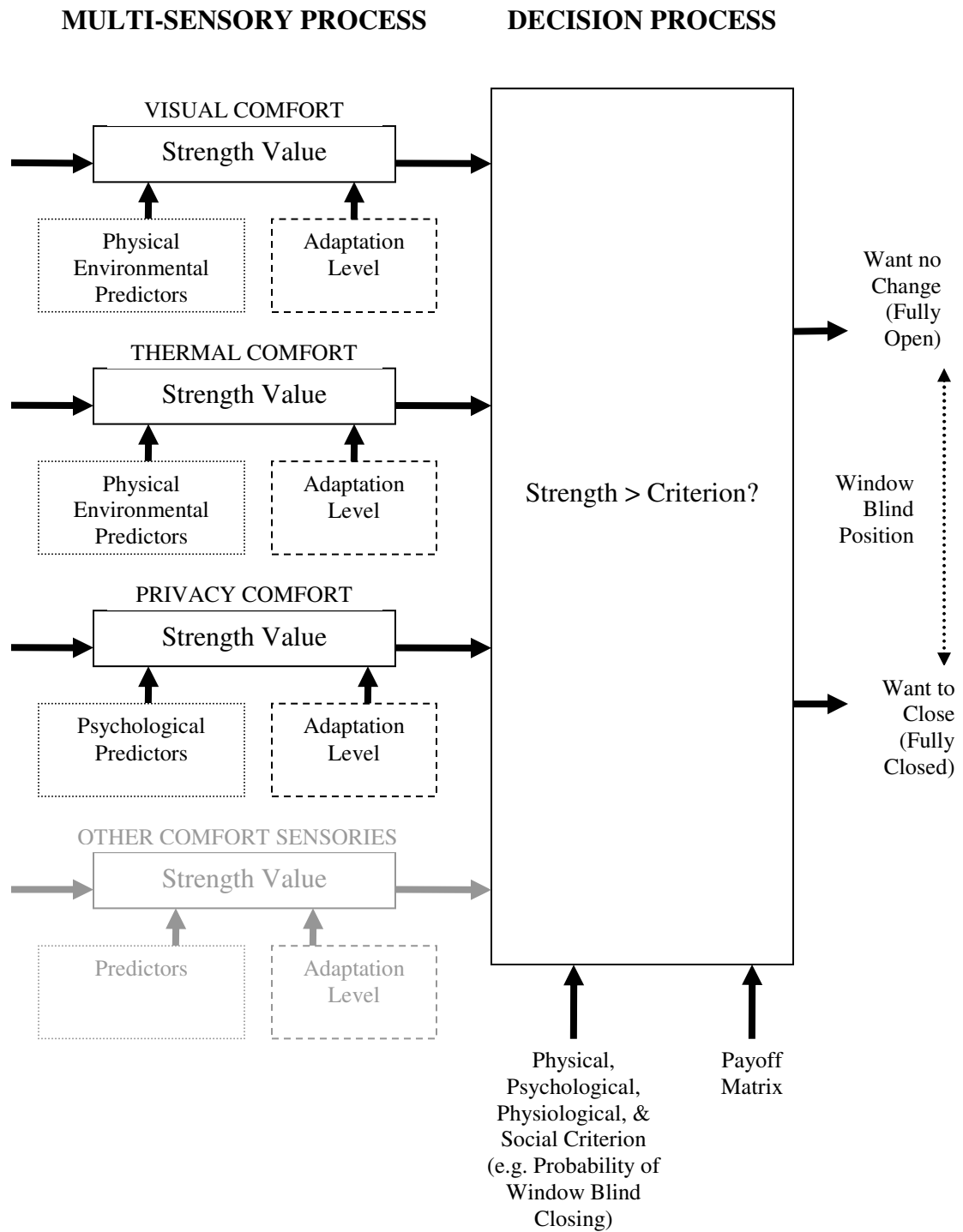

Figure 5.13 Two-stage process of window blind closing model modified from the two-stage process of Signal Detection Theory.

With the assumption that the initial state of a window blind is fully opened, in this modified model (see Figure 5.13), the window blind closing decision is based on a two-stage process: the initial multi-sensory process, which corresponds to the sub-systems of indoor comfort, followed by a decision process that operates on the output of the multi-sensory process. Based on the survey and field study data, only three sub-systems of indoor comfort (visual, thermal, and visual privacy) are highlighted. It is hypothesized that, if additional sub-systems of indoor comfort are found to influence the window blind control behaviors, they can be added to the multi-sensory process later.

For each sub-system of comfort, the intensity of the predictor stimulus as well as the adaptation level of an individual determines the strength value of signal that is sent to the decision process. Using visual comfort as an example, the predictor stimulus might consist of the maximum window luminance (Model V1 from Table 4.8). Age of a building occupant determines the adaptation level. In this example, the criterion for closing window blind could be based on a threshold value derived from Model M3 (from Table 4.18) which takes into account of the self-reported sensitivity to brightness (L_{sen} ; internal psychological criterion) in addition to the physical environmental criterion. The payoff matrix is defined as the costs and benefits of the final outcome, i.e. not closing the blind when it is bright outside leads to discomfort glare condition, closing the blind when it is bright outside leads to no glare condition, closing the blind when it is comfortable outside leads to a dark and gloomy interior environment, and not closing the blind when it is comfortable outside, the occupant can enjoy the view.

The data in this study showed that the self-reported sensitivity to brightness (L_{sen}) was not related to the estimation of discomfort glare sensation but was found to influence the window blind control behaviors. Therefore, it is suggested that the self-reported sensitivity to brightness should be considered as one of the criterion in the decision making process only.

5.7.4 Influence of local discomfort on global perception of comfort

Thus far, there is a lack of understanding on how multiple sub-systems of comfort influence the overall perception of comfort. However, recent thermal comfort and decision-making studies data (Hui, 2003; Cabanac et al., 2002; Pellerin et al., 2003) suggested that when modeling the brain's ranking of multiple (comfort) signals, more intense signal tends to overshadow less intense signals and the overall comfort correlated with local discomfort.

It seems logical to separate stimulus signals from various sub-system of sensory processes instead of having only one sensory process as in the original model and arrange the sub-system of sensory processes without any hierarchical order. With this arrangement, extreme discomfort sensation from one or more channels will trigger window blind closing events.

The investigator explored a few structural models that integrate physical and non-physical factors in the prediction of comfort and/or human behavior (Iwata et al., 1994; Elzeyadi, 2002). The structural model that represents most of the factors suggested in the literature and agrees with the survey and field study results is the two-stage process model (see Figure 5.13) that was modified from the Signal Detection Theory.

Nevertheless, the structure of the proposed window blind control model is not conclusive. Ultimately, the two-stage model is proposed as a hypothesis to be examined in future window blind control studies.

5.8 Discussion of visual comfort assessment

Lighting conditions in buildings are one of the most important factors affecting building occupants' comfort and well-being. While it is commonly agreed that daylighting strategies have significant potential to reduce energy consumption and produce better quality work environments, fundamental issues about glare from daylight have not been settled among lighting researchers. Because a part of this dissertation examined glare from daylight, a few issues that are related to the results and the assessment method are discussed below.

5.8.1 Discomfort glare prediction

Thus far, there are many predictive models for visual comfort. However, most of these models cannot be used to predict discomfort glare from windows with the exception of Hopkinson's Daylight Glare Index. Based on the hypothesis that building occupants primarily close window blinds for daylight glare protection, many luminance-based variables as well as the DGI were examined.

Regarding the hypothesis that the sensation of visual discomfort will increase as the magnitude of physical environmental predictors increase; the results (see Section 4.3.2.1) showed that the magnitude of discomfort sensation increased as a power function of the magnitudes of various stimuli. For the DGI, a linear relationship was found.

It was found that the coefficient of determinations (r^2) of the DGIs were lower than those of the luminance-based variables (see Table 4.10). This was consistent with previous studies (Osterhaus & Bailey, 1991; Osterhaus, 1998). While the window blind usage survey suggested that glare is the dominating factor in the closing of window blinds, the window blind control models were based on luminance variables instead of the DGIs.

In addition to the background luminance that was proposed in previous research as the discomfort glare predictor, this study found that the maximum window luminance, the average window luminance and the vertical solar radiation at window could also be used as discomfort glare predictors.

5.8.2 Multivariate models

All of the discomfort glare models (for small and large sources) share similar predictive equations which include luminance of the source (L_s), adaptation (or background) luminance (L_b), position of the source (p), and apparent size of the glare source (ω) (Boyce, 2003). All of these models can be expressed using the same general form:

$$G = \frac{L_s^a \cdot \omega_s^b}{L_b^c \cdot p^d} \quad (5.5)$$

Equation 5.4 suggests that the amount of glare increases with the luminance of the source and the solid angle subtended by the source, and decreases with increasing background luminance and deviation of the glare source from the line of sight. In this study, three multivariate models were derived for glare prediction. Background luminance served as a predictor in every model.

In contrast to Equation 5.4, it was found that the discomfort glare sensation increases with the luminance of the source and the background luminance (see Figure 4.25 to 4.27). One possible reason was that, in this study, the background luminance data, which was defined as the average luminance over the hemisphere of view, moderately correlated with the source variables (maximum window luminance and average window luminance). Therefore, the background luminance was related in part to the glare sources, unlike the calculation of glare from small sources, in which the background luminance is largely independent of the source luminance.

This finding agrees with previous studies which suggested that vertical luminance, which is equal to background luminance multiplied by Pi (π), may be used to predict discomfort glare (Osterhaus & Bailey, 1991; Osterhaus, 1998; Loe et al., 2000; Aries, 2003; Cuttle, 2003).

5.8.3 Contextual influences

Previous research suggested that the weak correlation between the predicted glare index and the reported glare sensation is due to the compounding influences of other visual and aesthetic factors such as view (Chauvel et al., 1982, Boubekri & Boyer, 1992). The results in this research (see Figure 5.14) includes evidence that supports this proposition.

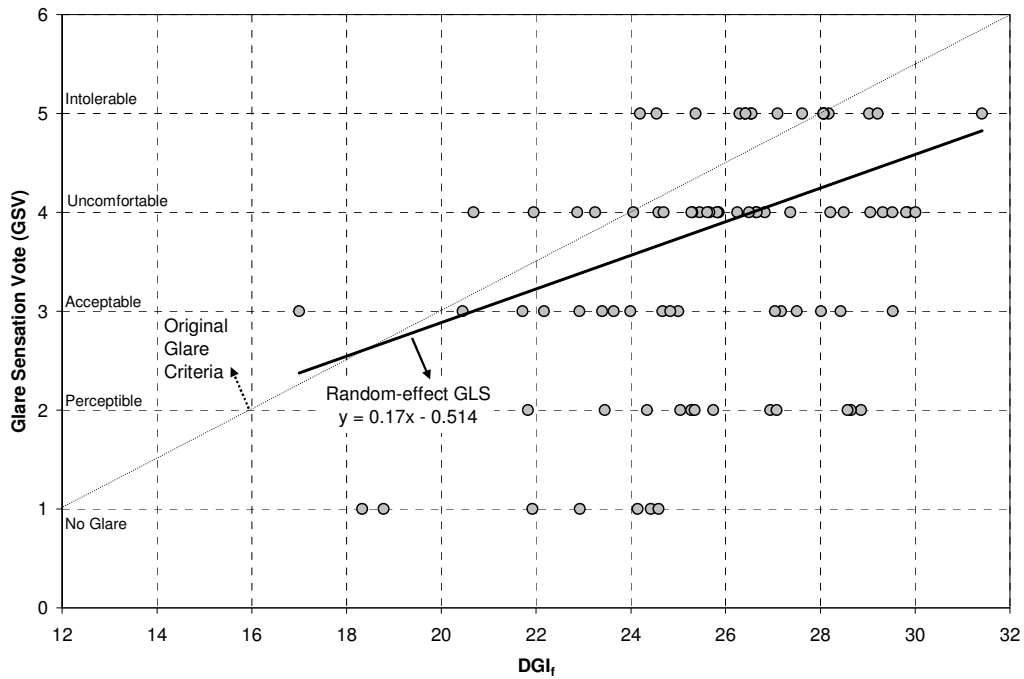

Figure 5.14 Scatterplot of glare sensation as a function of modified Daylight Glare Index.

Figure 5.14 shows that the slope of the observed glare sensation responses (dark line) is less steep than the slope of the original glare criteria (dotted line). It appears that the observed glare sensation may be affected by other contextual factors. This hypothesis remains to be tested.

CHAPTER 6

CONCLUSIONS

6.1 Recommendations for future work

6.1.1 Longitudinal analysis

Because of the limited number of participants, the project selected a longitudinal study as the primary data analysis method. In this method, within-subject covariates were taken into account. A comparison of models between standard and longitudinal regression showed that the majority of the models' regression coefficients were comparable. However, there were a few cases that the regression coefficients between models were distinctively different. For example, using background luminance as the glare predictor, the standard regression and the random-effect GLS models predicted that intolerable glare will be perceived at the background luminance values of 1,500 and 2,100 cd/m^2 respectively. Therefore, it is suggested that future research should use longitudinal data analysis if the data were repeatedly measured over time from a limited number of research participants.

6.1.2 Analysis of luminance characteristics

6.1.2.1 Recommended location for luminance measurements

In the current study, luminance characteristics were documented via two methods, digital camera (the Photolux system) and shielded luminance sensors. In the first method, the luminance characteristics were captured from the actual seating location of

the building occupants. On the other hand, shielded luminance sensors were placed at the back of the room, due to space limitations in the field setting.

The regression analysis in section 4.3.2.1 showed that the luminance data from the second method were weakly correlated to the subjective discomfort glare sensation. It was implied that luminance measurement for the assessment of visual comfort is location-dependent (see Figure 6.1). As Figure 6.1 shows, the Photolux digital pictures were taken from the actual seating location (Position A). The sensor poles were placed at the back of the room (Position B). The areas labeled C indicate the areas for which the luminance values were not included by the shielded luminance sensor in comparison with the Photolux system.

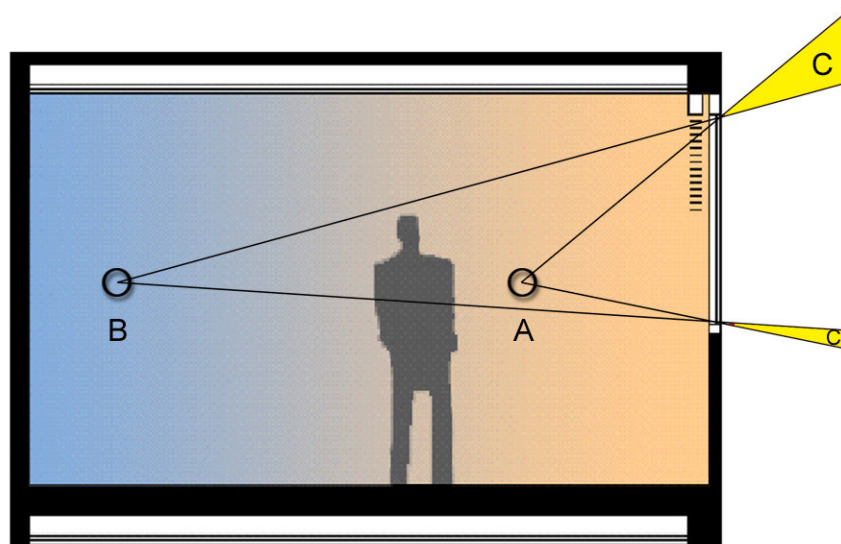

Figure 6.1 Limited registration of luminance values as a consequence of the luminance sensor position at the back of the room (Position B). The Photolux pictures were taken from the actual seating position (Position A). The areas labeled C indicates the area for which the luminance values were not included by the shielded luminance sensor.

The examination of luminance data shows that area C may cause discrepancies in data measurements because this study was conducted in actual office space in which the brightness of the window was not uniformly distributed, as it is in laboratory studies.

Vertically, area C may cover bright sky. Horizontally, area C may include bright reflection from buildings across the street. Therefore, it was suggested for the assessment of visual comfort, luminance data should be measured as close as possible to the actual seating location.

6.1.2.2 Second-generation digital luminance map program

The luminance maps in this study were generated with the Photolux Luminance Mapping System which was available as a licensed product (200 Euros/student license as of May 2004). While the luminance capturing capability of Photolux exceeds the traditional method of handheld luminance meters, there were a few disadvantages. For example, the size of the output luminance maps was too small, the luminance value per pixel could not be exported into a spreadsheet format, and, because it is not an open source program, many configurations, such as the false color legend bar could not be manipulated. Finally, the generation of luminance maps and the analysis of luminance characteristics must be done manually. Therefore, the analysis tended to be a tedious task.

Concurrent with this study, a second-generation luminance map program, Photosphere, is being developed. The program is developed by Greg Ward and available for free download at <http://www.anywhere.com>. This program eliminates some of the limitations of Photolux in that the luminance map output is large, luminance value per

pixel can be exported into a spreadsheet format, which enables detailed analysis of luminance characteristics to be conducted, and the luminance data can also be exported for use with other simulation programs such as Radiance and MATLAB for complex mathematical calculations. Finally, the luminance maps can be automatically generated with some programming. The only disadvantage is that the program is not suitable for novice users and usually requires some basic programming knowledge.

Despite the minor disadvantages, it is suggested that future visual comfort studies consider using Photosphere as the method to generate high-dynamic range images.

6.1.3 Additional window blind usage studies are needed

In addition to having a limited number of participants, data were collected in a particular geographical area during a particular climatic context. In this study, longitudinal data analysis techniques were used to ensure that the within-subject covariance was taken into consideration. While the research hypotheses were supported in this study, the results were population-averaged in which the interaction effects between independent variables were not examined in detail. The results only revealed a snapshot of window blind usage for a particular condition in which many factors were not examined in detail. This study found that there are many additional contextual and psychological factors that influence window blind control. Below are a few factors that should be investigated in future studies.

1. Brightness sensitivity

This research found that the self-reported brightness sensitivity of an individual influences window blind control behavior. The window blind control behavior of participants with different levels of self-reported brightness sensitivity should be systematically compared. It is anticipated that the percentage of a model's correct predictions will increase if the self-reported brightness sensitivity levels are carefully integrated in the model. This might include a study of window blind usage between two age groups of participants because older participants are likely to be more sensitive to light.

2. Magnitude of direct solar penetration and window brightness

In this study, it was found the magnitude of solar penetration and window brightness influence how building occupants control window blinds. For example, it was found that building occupants on the north façade usually leave their window blinds open or close the blinds down only to reduce glare from bright sky (and clouds). Therefore, comparison of window blind usage between levels of direct solar penetration (which varies with season, time, façade orientation, and glazing Solar Heat Gain Coefficient) and window brightness (which varies with glazing visible transmittance) could yield potentially different window blind control behaviors.

3. Background luminance

In daylight-linked lighting/blind control systems, overhead lights are often turned off or lowered when daylight is ample. In this study, the electric lighting usage (which provides background light level) was not controlled. The overhead lights were usually turned on during the field study. Because brightness adaptation plays a major role in the

determination of visual comfort, it would be beneficial to understand the psychological and physiological impact of brightness adaptation (from the presence of overhead lighting) on window blind control behaviors.

4. Task type and task luminance

Task type (paper-based and computer-based) and task luminance play a major role in the visual comfort perception and could influence the window blind control behaviors. In this study, the average task luminance from the VDT screen was 120 cd/m² (most of the field study participants had Cathode-Ray Tube). Based on the window blind control model, the average window luminance threshold value for closing window blinds was 890 cd/m². However, the results from a separate study (Clear et al., 2005), which monitored subjective responses to electrochromic windows, showed that the average window luminance threshold value was 2,000 cd/m². In that study, the average computer monitor (Liquid Crystal Display, LCD) brightness was 220 cd/m². Therefore, it was hypothesized that task type and task luminance may influence how building occupants control window blinds. It is suggested that future studies should address this issue in detail.

5. Shade type and window luminance

The results of this study showed that the average window luminance influences window blind control behavior. However, this study only asked if the building occupants would lower their venetian blinds if the blinds were fully raised. In actual settings, window blinds may be lowered half way down as an initial condition. The study of the interaction between building occupants and window blinds at intermediate positions

(between fully closed and fully open) will be beneficial in understanding window blind control behavior.

In addition, the current study examined only one type of interior shade: Venetian blinds. Currently there are many types of interior shade available, including fabric shades, vertical blinds, and highly reflective blinds. It is hypothesized that the control behavior for different interior shade types will be different due to their complex optical properties as well as occupants' preferences. Therefore, future research should look into this subject in detail.

6.1.4 Additional considerations for future automated blind systems

This study only reported the answer to how and why building occupants control window blinds. While the models can be directly applied to computer simulation programs, how future automated window blinds should be controlled in response to building occupants preferences was not fully investigated.

The survey data showed that building occupants were skeptical about automated window shading systems. Comments from survey respondents and the subsequent field study results suggested a few key issues that future automated window blind systems should incorporate. First, visual comfort is the main factor for closing window blinds in office setting. Optimization of window blinds to reduce glare while maintaining access to natural light and view should play a major role in the design of future automated window blind systems. Secondly, building occupants should be able to fine-tune an automated control system in real-time. At the most fundamental level, building occupants should be able to program and override the automated systems.

At a higher level, neural network control, which learns how building occupants control their window blinds, might be implemented.

6.2 Conclusions

The goal of this study was to develop predictive window blind control algorithms that can be used as a function in energy simulation programs, and to provide the basis for the development of future automated shading systems. To achieve this goal, a two-part study was conducted consisting of a window blind usage survey and a field study. A total of one hundred and thirteen building occupants in Berkeley, California, USA, participated in the window blind usage survey. Twenty-five occupants who participated in the survey were selected to participate in a detailed window blind usage field study, in which window blind movement and physical environmental conditions were unobtrusively monitored for a period of one week. On the last day of the field study, participants were surveyed multiple times for their window blind closing preferences. Measurements of physical environmental conditions were gathered simultaneously and cross-linked to the participants' assessment of visual and thermal comfort sensations.

Results from the window blind usage survey showed that window blinds were closed for multiple reasons, among which the reduction of glare from sunlight and bright windows was the primary closing reason. Thermal comfort and visual privacy were specified as subsidiary reasons. A preliminary hierarchical window blind control model, which consists of physical and psychological criteria, was proposed from the survey data for further analysis.

From the field study, a total of thirteen predictive window blind control models were derived. These window blind control models use only physical and psychological criteria in determining window blind control behavior. These models express window blind closing behavior as a probability function of physical environmental predictors and confounding factors which are related to the occupants' perception of visual and thermal comfort. As hypothesized, the probability of a window blind closing event increased as the magnitude of physical environmental and confounding factors increased. The main predictors are maximum window luminance, average window luminance, background luminance and vertical solar radiation transmitted through the window. The confounding factors include Mean Radiant Temperature, direct solar penetration, and self-reported sensitivity to brightness. The results show that the models correctly predict between 73 – 89 % of the actual window blind control behavior.

The significance of the derived predictive window blind control models is that the models were derived from empirical investigation instead of theoretical assumptions. The models can be easily implemented in energy simulation programs such as DOE-2 or EnergyPlus, as well as used as a basis for the development of future automated window blind systems. Unlike existing window blind control models, window blind control behavior can be predicted for all façade orientations. Most importantly, because the models are expressed as probability functions, window blinds can be controlled based on threshold values or probability values.

In addition to the window blind control models, a new method for assessing visual comfort sensation from daylight from digital luminance map was examined. This study found that sensation of discomfort glare from daylight was moderately correlated with the main predictors of the logistic model, mentioned above. The results suggested that luminance-based variables could be used as discomfort glare predictors as superior alternative to the existing Daylight Glare Index.

The results presented in this study are merely a snapshot of how building occupants control window blinds based on a specific group of participants in particular climatic and contextual conditions. Many factors that could potentially influence window blind control behaviors were considered in this study. This dissertation extends the knowledge of how and why building occupants manually control window blinds in private offices, and provides results that can be directly implemented in energy simulation programs. Future work is needed to develop control algorithms that maintain satisfaction while allowing the energy-saving potential of automated window blinds to be fully realized.

BIBLIOGRAPHY

- Agresti, A., & Finlay, B. (1997). *Statistical methods for the social science (3rd Ed.)*. Upper Saddle River, NJ: Prentice Hall.
- Aizlewood, M. (2001). *Appendix C: Assessment of glare in Veld, M., & Christoffersen, J. Monitoring procedures for the assessment of daylighting performance of buildings, A report of IEA SHC Task 21/ ECBCS Annex 29.*
- Akaike, H. (1973). Information theory and an extension of the maximum likelihood principle. In B.N. Petrov and F. Csaki (Eds.), *2nd International Symposium on Information Theory* (pp. 267-281). Budapest; Akademiai Kiado.
- American Psychological Association (2001). *Publication Manual of the American Psychological Association (5th Edition)*. Washington, DC: APA.
- American Society of Heating, Refrigerating and Air-Conditioning Engineers. (1992). *Thermal environmental conditions for human occupancy, ASHRAE Standard 55*, Atlanta, GA: ASHRAE.
- American Society of Heating, Refrigerating and Air-Conditioning Engineers (ASHRAE). (1997). *Handbook of Fundamentals*. Atlanta, GA: American Society of Heating Refrigerating and Air-Conditioning Engineers.
- American Society of Heating, Refrigerating and Air-Conditioning Engineers (ASHRAE). (2000). *ASHRAE Handbook of fundamentals*. Atlanta, GA: ASHRAE.
- American Society of Heating, Refrigerating and Air-Conditioning Engineers (ASHRAE). (2004). *Thermal environmental conditions for human occupancy, ASHRAE Standard 55*, Atlanta, GA: ASHRAE.
- Andersen, M. (2002). Light distribution through advanced fenestration systems. *Building Research & Information*, 30(4), 264-281.
- Andersen, M., Michel, L., Roecker, C., & Scartezzini, J-L. (2001). Experimental assessment of bi-directional transmission distribution functions using digital imaging techniques. *Energy and Buildings*, 33, 417-431.
- Andersen, M., Rubin, M., Powles, P., Scatezzini, J-L. (2005). Bi-directional transmission properties of venetian blinds: Experimental assessment compared to ray-tracing calculations. *Solar Energy*, 78, 187-198.
- Arasteh, D. (1996). *Advances in Window Technology: 1973-1993 (LBL-36891)*. Berkeley, CA: Lawrence Berkeley National Laboratory.

- Aries, M.B.C., Begemann, S.H.A., Tenner, A.D., & Zonneveldt, L. (2003). Retinal illuminance, a new design parameter? *Proceedings of the 25th Session of the CIE, San Diego, USA, D3* (52-55).
- Assimakopoulos, M.N., Tsangrassoulis, A., Guarracino, G., & Santamouris, M. (2004). Integrated energetic approach for controllable electrochromic device. *Energy and Buildings*, 36, 415-422.
- Athienitis A.K., & Tzempelikos, A. (2002). A methodology for simulation of daylight room illuminance distribution and light dimming for a room with a controlled shading device. *Solar Energy*, 72(4), 271-281.
- Babbie, E.R. (1979). *The Practice of Social Research* (2nd Edition). Belmont, CA: Wadsworth.
- Baker, N.V., & Steemers, K. (2002). *Daylight design of buildings*. London, UK: James & James.
- Banham, R. (1969). *The architecture of the well-tempered environment*. London, UK: Architectural Press.
- Baird, G. (2001). *The architectural expression of environmental control systems*. London, UK: Spon Press.
- Bennett, C.A. (1977). The demographic variables of discomfort glare. *Lighting Design and Applications*, 7(1), 22-24.
- Benton, C.C. (2003) Personal communication, January 22, 2003.
- Bodmann, H. W. (1967). Quality of interior lighting based on luminance. *Transaction of Illuminating Engineering Society (London)*, 32(1), 22-40.
- Bodmann, H. W., & La Toison, M. (1994). Predicted brightness - luminance phenomena. *Lighting Research and Technology*, 26, 135-143.
- Bordass, W., Bromley, K., & Leaman, A. (1993). User and occupant controls in office building. Proceedings of the Building Design, Technology and Occupant Well-being in Temperate Climates Conference.
- Bordass, B., Cohen, R., Standeven, M., & Leaman, A. (2001). Assessing building performance in use 2: Technical performance of Probe buildings. *Building Research and Information* 29(2), 103-113.
- Boubekri, M., & Boyer, L.L. (1992). Effect of window size and sunlight presence on glare. *Lighting Research and Technology*, 24(2), 69-74.

- Boyce, P.R. (2003). *Human factor in lighting* (2nd Ed.). New York, NY: Taylor & Francis.
- Brager, G. S., & De Dear, R. (1998). Thermal adaptation in the built environment: A literature review. *Energy and Buildings*, 27, 83-96.
- Brager, G.S., & De Dear, R.J. (2003). Historical and cultural influences on comfort expectations in Cole, R.J., & Lorce, R. (Eds.). *Buildings, Culture and Environment: Informing local and global practices* (pp. 177-201). Oxford, UK: Blackwell.
- Brager, G.S., Paliaga, G., & De Dear, R.J. (2004). Operable windows, personal control, and occupant comfort. *ASHRAE Transaction*, 110(1), 17-36.
- Breitenbach, J., Lart, S., Langle, I., & Rosenfeld, J.L.J. (2001) Optical and thermal performance of glazing with integral venetian blinds. *Energy and Buildings*, 33, 433-442.
- Bülow-Hübe, H. (2001). Energy-efficient window systems: Effects on energy use and daylight in buildings. Ph.D. Dissertation, Lunds University, Sweden.
- Burnham, K.P., & Anderson, D.R. (2001). Kullback-Leibler information as a basis for strong inference in ecological studies. *Wildlife Research*, 28, 111-119.
- Burrutto, V. (1997). Importance of wall illuminance on users satisfaction: Pilot study on 73 office workers. *Proceedings of the 8th European Lighting Conference*, Amsterdam, The Netherlands, 82-101.
- Cabanac, M., Guillaume, J., Balasko, M., & Fleury, A. (2002). Pleasure in decision-making situations. *BMC Psychiatry*, 2(7). Retrieved on May 30, 2005, from <http://www.biomedcentral.com/1471-244X/2/7>
- Carmody, J., Selkowitz, S.E., & Heschong, L. (1996). *Residential Windows: A Guide to New Technologies and Energy Performance*. New York, NY: W.W. Norton.
- Chauvel, P., Collins, J.B., Dogniaux, R. & Longmore, J. (1982). Glare from windows: Current views of the problem. *Lighting Research and Technology*, 14(1), 31-46.
- Christoffersen, J. (1995). *Daylight Utilization in Office Buildings*. Ph.D. Dissertation, Technical University of Denmark, Hørsholm, Denmark.
- CIBSE (1996). City Slicker. *CIBSE Journal*, 18(9), 20-24.
- Clear, R.D., Inkarojrit, V., & Lee, E.S. (2005). Subject responses to electrochromic windows. Article submitted to *Energy and Buildings*.

- Collins, B. L. (1975). *Windows and people: NBS Building Science Series 70*. Washington, DC: National Bureau of Standards.
- Collins, B. L. (1976). Review of the psychological reaction to windows. *Lighting Research and Technology*, 8(2), 80-88.
- Cook, T.D., & Campbell, D.T. (1979). *Quasi-Experimentation*. Chicago, IL: Rand McNally College Publication.
- Coutelier, B., & Dumortier, D. (2004). Luminance calibration of the Nikon Coolpix 990 digital camera. *Proceedings of the International Commission on Illumination (CIE) 2003 Conference, San Diego, CA*, D3-(56-59).
- Crawley, D.B., Lawrie, L.K., Winkelmann, F.C., Buhl, W.F., Huang, Y.J., Pedesen, C.O., Strand, R.K., Liesen, R.J., Fisher, D.E., Witte, M.J., & Glazer, J. (2001). EnergyPlus: Creating a new-generation building energy simulation program. *Energy and Buildings*, 33, 319-331.
- Crowley, J.E. (2001). *The Invention of Comfort: Sensibilities & Design in Early Modern Britain & Early America*. Baltimore, MD: The John Hopkins University Press.
- Cuttle, C. (2003). *Lighting by design*. Oxford, UK: Architectural Press.
- De Dear, R.J., & Brager, G.S. (1998). Developing an adaptive model of thermal comfort and preference. *ASHRAE Transactions*, 104(1), 145-167.
- Dubois, M-C. (2003). Shading devices and daylight quality: An evaluation based on simple performance indicators. *Lighting Research and Technologies*, 35(1), 61-76.
- Einhorn, H.D. (1969). A new method for the assessment of discomfort glare. *Lighting Research and Technology*, 1(4), 235-247.
- Einhorn, H.D. (1979). Discomfort glare: A formula to bridge differences. *Lighting Research and Technology*, 11(2), 90-94.
- Einhorn, H. D. (1998). Unified Glare Rating (UGR): Merits and application to multiple sources. *Lighting Research and Technology*, 30(2), 89-93.
- Eley Associates (2002). *Market Research Report: A Characterization of the Non-residential Fenestration Market*. San Francisco, CA: Eley Associates. Retrieved from <http://www.nwalliance.com> on February 14, 2003.
- Elliot, C.D. (1992). *Technics and Architecture*. Cambridge, MA: MIT Press.

- Elzeyadi, I. (2002). Designing for indoor comfort: A systematic model for assessing occupant comfort in sustainable office buildings. *Proceedings of the Solar 2002/31st ASES Annual Conference*. 485-497.
- Escuyer, S., & Fontoynt, M. (2001). Lighting controls: A field study of office workers' reactions. *Lighting Research and Technology*, 33(2), 77-96.
- Fanger, P.O. (1970). *Thermal comfort: Analysis and applications in environmental engineering*. New York, NY: McGraw-Hill.
- Fanger, P.O. (1982). *Thermal comfort*. Malabar, FL: Robert E. Krieger Publishing.
- Fanger, P.O., Breum, N.O., & Jerking, E. (1977). Can color and noise influence man's thermal comfort. *Ergonomics*, 20(1), 11-18.
- Fanger, P.O., & Langkilde, G. (1975). Interindividual differences in ambient temperature preferred by seated persons. *ASHRAE Transactions*, 81(2), 140-147.
- Fechner, G.T. (1860). *Elemente der Psychophysik*. Vol. I available in English translation as *Elements of psychophysics*. New York, NY: Rinehart and Winston, 1966.
- Fisekis, K., Davies, M., Kolokotroni, M., & Langford, P. (2003). Prediction of discomfort glare from windows. *Lighting Research and Technology*, 35(4), 360-371.
- Fisher, J.A., & Christie, A.W. (1965). A note on disability glare. *Vision Research*, 5, 565.
- Fitch, J.M. (1972). *American building: The environmental forces that shape it*. New York: Oxford University Press.
- Forster, M. R. (2000). Key concepts in model selection: Performance and generalizability. *Journal of Mathematical Psychology*, 44, 205-231.
- Foster, M., & Oreszczyn, T. (2001). Occupant control of passive systems: the use of Venetian Blinds. *Building and Environment* 36, 149-155.
- Fountain, M. E., & Huizenga, C. (1997). A thermal sensation prediction tool for use by the profession. *ASHRAE Transactions*, 103(2), 130-136.
- Gage, A.P., Fobelets, A.P., & Berglund, L. (1986). A standard predictive index of human response to thermal environment. *ASHRAE Transaction*, 92(2), 709-731.
- Green, D.M. & Swets, J. (1966). *Signal detection theory and psychophysics*. New York, NY: Wiley.
- Guillemin, A., & Molteni, S. (2002). An energy-efficient controller for shading devices self-adapting to user wishes. *Building and Environment*, 37, 1091-1097.

- Guillemin, A., & Morel, N. (2001). An innovative lighting controller integrated in a self-adaptive building control system. *Energy and Buildings* 33, 477-487.
- Guillemin, A., & Morel, N. (2002). Experimental results of a self-adaptive integrated control system in buildings a pilot study. *Solar Energy*, 72(5), 397-403.
- Hardin, J. W., & Hilbe, J.M. (2003). *Generalized estimating equations*. Boca Raton, FL: Chapman & Hall/CRC.
- Hawkes, D. (1996). *The environmental tradition: Studies in the architecture of environment*. London, UK: E & FN Spon.
- Hawkes, D. & Forster, W. (2002). *Architecture, engineering and environment*. London, UK: Laurence King Publication in association with Arup.
- Hawkes, D., McDonald, J., & Steemers, K. (2002). *The selective environment*. London, UK: Spon Press.
- Heerwagen, J.H. (1990). The psychological aspects of windows and window design. *Proceedings of the EDRA 21 Conference, Washington, DC*, 269-280.
- Heschong, L. (2002). Daylighting and human performance. *ASHRAE Journal*, 44(6), 65-68.
- Heschong, L., Wright, R. L., & Okura, S. (2002a). Daylighting impact on retail sales performance. *Journal of the Illuminating Engineering Society*, 31(2), 21-26.
- Heschong, L., Wright, R.L., & Okura, S. (2002b). Daylighting impacts on human performance in school. *Journal of the Illuminating Engineering Society*, 31(2), 101-115.
- Hopkinson, R.G. (1949). Studies of lighting and vision in school. *Transaction of the Illuminating Engineering Society (London)*, 14(8), 244-268.
- Hopkinson, R.G. (1950). The multiple criterion technique of subjective appraisal. *The Quarterly Journal of Experimental Psychology*, 2, 124.
- Hopkinson, R.G. (1963). *Architectural Physics: Lighting*. London, UK: Her Majesty's Stationery Office.
- Hopkinson, R.G. (1972). Glare from Daylighting in Buildings. *Applied Ergonomics*, 3(4): 206-215.
- Hopkinson, R.G., & Bradley, R.C. (1960). A study of glare from very large sources. *Illuminating Engineering*, 55(5), 288-294.

- Hopkinson, R.G., & Collins, W.M. (1963). An experimental study of the glare from a luminous ceiling. *Transaction of Illuminating Engineering Society (London)*, 28(4), 142-148.
- Hopkinson, R.G., & Collins, J.B. (1970). *The ergonomics of lighting*. London, UK: McDonald & Co.
- Hopkinson, R.G., Petherbridge, P., & Longmore, J. (1966). *Daylighting*. London, UK: Heinemann.
- Hosmer, D. W., & Lemeshow, S.L. (1989). *Applied logistic regression*. New York, NY: Wiley.
- Hui, Z. (2003). *Human Thermal Sensation and Comfort in Transient and Non-Uniform Thermal Environments*. Unpublished doctoral dissertation, University of California, Berkeley.
- Humphreys, M. A., & Nicol, J.F. (1998). Understanding the adaptive approach to thermal comfort. *ASHRAE Transactions*, x(x), 991-1004.
- Hunt, D.R.G. (1979). The use of artificial lighting in relation to daylight levels and occupancy. *Building and Environment*, 14, 21-33.
- Hunt, D.R.G. (1980). Predicting artificial lighting use – a method based upon observe pattern of behavior. *Lighting Research and Technology*, 12(1), 7-14.
- Hunt, D.R.G., & Crisp, V.H.C. (1978). Lighting controls: their current use and possible improvement. *Energy Research*, 2, 343-374.
- IBM (n.d.). *Healthy computing: Lighting*. Retrieved August 2, 2004, from <http://www.pc.ibm.com/ww/healthycomputing/vdt19.html>
- Illuminating Engineering Society (1947). *IES Lighting Handbook: The standard lighting guide*. New York, NY: Illuminating Engineering Society.
- Illuminating Engineering Society (1952). *IES Lighting Handbook: The standard lighting guide* (2nd Ed.). New York, NY: Illuminating Engineering Society.
- Illuminating Engineering Society (1959). *IES Lighting Handbook* (3rd Ed.). New York, NY: Illuminating Engineering Society.
- Illuminating Engineering Society of North America (1987). *IES Lighting Handbook* (1987 Application Volume). New York, NY: IESNA.

- Illuminating Engineering Society of North America. (1999). *Recommended practice of daylighting* (IESNA RP-5-99). New York, NY: IESNA.
- Illuminating Engineering Society of North America. (2000). *IESNA Lighting Handbook* (9th Edition). New York, NY: IESNA.
- Inkarojrit, V., & Paliaga, G. (2004). Indoor climatic influences on the operation of windows in a naturally ventilated building. In M.H. de Wit (Ed.), *Proceedings of the 21st Passive and Low Energy Architecture Conference: Vol. 1.* (pp. 427-431). Eindhoven, Netherlands: Technische Universiteit Eindhoven.
- Inkarojrit, V., Lee, E.S., & Clear, R.D. (2005). Visual quality assessment of office with Electrochromic glazing. LBNL unpublished raw data.
- Inoue T., Kawase, T., Ibamoto, T., Takakusa, S., & Matsuo, Y. (1988). The development of an optimal control system for window shading devices based on investigations in office building. *ASHRAE Transactions*, 104, 1034-1049.
- Inoue, T., & Itoh, K. (1989). Methodological study of dynamic evaluation of discomfort glare. *Journal of Architecture, Planning, and Environmental Engineering, Transaction of the Architects Institute of Japan*, 398, 9-19, cited in Iwata et al. (1998).
- International Commission on Illumination (CIE) (1983). *Discomfort Glare in the Interior Working Environment, Publication CIE No. 55 (TC-3.4)*. Paris: Commission Internationale de l'Eclairage.
- International Commission on Illumination (CIE) (1987). *Method of characterizing illuminance meters and luminance meters, Publication CIE No.69*. Paris: Commission Internationale de l'Eclairage.
- International Commission on Illumination (CIE) (1995). *Discomfort Glare in the Interior lighting, Publication CIE No. 117*. Paris: Commission Internationale de l'Eclairage.
- International Energy Agency (IEA) Solar Heating and Cooling Program (n.d.) *Task 31: Daylighting buildings in the 21st Century*. Retrieved January 27, 2003, from <http://www.iea-shc.org/task31>
- Iwata, T., Kimura, K., Shukuya, M. & Takano, K. (1990/1991). Discomfort caused by wide-source glare. *Energy and Buildings*, 15-16, 391-398.
- Iwata, T., Hatao, A., Shukuya, M., & Kimura, K. (1994). Visual comfort in the daylight luminous environment: Structural model for evaluation. *Lighting Research and Technology*, 26(2), 91-97.

- Iwata, T., & Tokura, M. (1998). Examination of the limitations of predicted glare sensation vote (PGSV) as a glare index for a large source. *Lighting Research and Technology*, 30(2), 81-88.
- Iwata, T., Tokura, M., Shukuya, M., & Kimura, K-I. (1993). A pilot experiment on a method for evaluating acceptability of a daylight luminous environment. *Journal of Thermal Biology*, 18(5/6), 555-559.
- Jain, P. (1998). *Occupant response to the automatic interior shading system at the new main San Francisco Public Library*. M.S. Thesis. University of California, Berkeley: 339.
- Japee, S. A. (1995). *A method for glare analysis*. Unpublished M.S. Thesis, University of Southern California, Los Angeles.
- Jones, N.N. (1941). The resuscitation of the venetian in Thomas French & Sons. *Venetian blinds*. Manchester, UK: Branch factory.
- Kim, I-K. (1997). *Subjective Responses to Daylight, Sunlight, and View in College Classrooms with Windows*. Unpublished Doctoral Dissertation. Texas A&M University.
- Kleinbaum, D. G., & Klein, M. (2002). *Logistic regression: A self-learning text* (2nd Ed.). New York, NY: Springer-Verlag.
- Klems, J.H., & Warner, J.L. (1997). Solar Heat Gain Coefficient of complex fenestrations with a venetian blind for differing slat tilt angles. *ASHRAE Transaction*, 103(1), 1026-1034.
- Kolokotsa, D. (2003). Comparison of the performance of fuzzy controllers for the management of the indoor environment. *Building and Environment*, 38, 1439-1450.
- Kolokotsa, D., Niachou, K., Geros, V., Kalaitzakis, K., Stavrakakis, G. S., & Santamouris, M. (2005). Implementation of an integrated indoor environment and energy management system. *Energy and Buildings*, 37, 93-99.
- Kolokotsa, D., Tsiavos, D., Stavrakakis, G.S., Kalaitzakis, K. & Antonidakis, E. (2001). Advanced fuzzy logic controllers design and evaluation for buildings' occupants thermal-visual comfort and indoor air quality satisfaction. *Energy and Buildings*, 33, 531-543.
- Laurentin, C., Berrutto, V., & Fontoynt, M. (2000). Effect of thermal conditions and light source type on visual comfort appraisal. *Lighting Research and Technology*, 32(4), 223-233.

- Lawrence Berkeley National Laboratory (2005). *Daylighting the New York Times Headquarters Building*. Retrieved May 9, 2005, from http://windows.lbl.gov/comm_perf/newyorktimes.htm
- Leaman, A., & Bordass, B. (1999). Productivity in buildings: The 'killer' variables. *Building Research and Information*, 27(1), 4-19.
- Lechner, N. (2001). *Heating, Cooling, Lighting: Design methods for architects* (2nd Ed.). New York, NY: John Wiley & Sons.
- Lee, E.S., & Selkowitz, S.E. (1995). The design and evaluation of integrated envelope and lighting control strategies for commercial buildings. *ASHRAE Transactions*, 101(1), 326-341.
- Lee, E.S., & Selkowitz, S.E. (1997). *Design and performance of an integrated envelope/lighting system* (LBNL-39729). Berkeley: Lawrence Berkeley National Laboratory.
- Lee, E.S., DiBartolomeo, D.L., Selkowitz, S.E. (1998). Thermal and daylighting performance of an automated venetian blind and lighting systems in a full-scale private office. *Energy and Buildings*, 29(1), 47-63.
- Lee, E.S., Zhou, L., Yazdani, M., Inkarojrit, V., Slack, J., Rubin, M., & Selkowitz, S.E. (2002). *Energy performance analysis of electrochromic windows in New York commercial office buildings*. (LBNL-50096). Berkeley, CA: Lawrence Berkeley National Laboratory.
- Leslie, R.P., Raghaven, R., Howlett, O., & Eaton, C. (2005). The potential of simplified concepts for daylight harvesting. *Lighting Research and Technologies*, 37(1), 21-40.
- Liang, K-Y., & Zeger, S.L. (1986). Longitudinal data analysis using generalized linear models. *Biometrika*, 73, 45-51.
- Lindsay, C.R.T., & Littlefair, P.J. (1993). *Occupant use of venetian blinds in offices* (PD 233/92). Watford: Building Research Establishment.
- Littlefair, P.J. (1999). *Solar shading of buildings*. London: Construction Research Communications by permission of Building Research Establishment.
- Loe, D. L., Mansfield, K.P., & Rowlands, E. (1994). Appearance of lit environment and its relevance in lighting design: Experimental study. *Lighting Research and Technology*, 26(3), 119-133.
- Love, J. A. (1998). Manual Switching Patterns in Private Offices. *Lighting Research and Technology*, 30(1), 45-50.

- Luckiesh, M. (1944). *Light, vision and seeing: A simplified presentation of their relationship and their importance in human efficiency and welfare*. New York, NY: D. Van Nostrand.
- Ludlow, A. M. (1976). The functions of windows in buildings. *Lighting Research and Technology*, 8(2): 57-68.
- Mahone, D. (1989). Hugh building prototype for large-scale daylighting design. *Architectural Lighting*, 3(4), 23-26.
- Manning, P. (Ed.). (1965). *Office Design: A Study of Environment*. Pilkington Research Unit, Department of Building Science, University of Liverpool, England.
- Marans, R. W., & Spreckelmeyer, K.F. (1982). Evaluating open and conventional office design. *Environment and Behavior*, 14(3), 333-351.
- Marans, R. W., & Yan, X. (1989). Lighting quality and environmental satisfaction in open and enclosed offices. *Journal of Architectural and Planning Research*, 6(2), 118-131.
- Markus, T. A. (1965). The significance of sunshine and view for office workers. Proceedings of the C.I.E. Intersessional Conference: Sunlight in Buildings, University of Newcastle-upon-Tyne.
- Markus, T.A. (1967). The function of windows: A reappraisal. *Building Science*, 2, 97-121.
- Marsden, A.M. (1969). Brightness – a review of current knowledge. *Lighting Research and Technology*, 1, 171-181.
- Marsden, A.M. (1970). Brightness-luminance relationships in an interior. *Lighting Research and Technology*, 2, 10-16.
- McIntyre, D.A. (1980). *Indoor climate*. London, UK: Applied Science Publishers.
- McIntyre, D.A. & Gonzalez, R.R. (1976). Man's thermal sensitivity during temperature changes at two levels of clothing insulation and activity. *ASHRAE Transactions*, 82(2), xx-xx.
- McKenna, S. (1997). The view of the new sky. *Glass Magazine*, 47(5), 98-102.
- Menard, S. (2002). *Applied logistic regression analysis*. Thousand Oaks, CA: Sage.
- Merriam-Webster's collegiate dictionary* (11th ed.). (2003). Springfield, MA: Merriam-Webster.

- Miles, J., & Shelvin, M. (2004). *Applying regression & correlation: A guide for students and researchers*. Thousand Oaks, CA: Sage.
- Miller, A. (2002). *Subset selection in regression* (2nd Ed.). Boca Raton, FL: Chapman & Hall/CRC.
- Moeck, M., Lee, E.S., Rubin, M.D., Sullivan, R., & Selkowitz, S.E. (1996). *Visual quality assessment of electrochromic and conventional glazings* (LBNL-35486). Berkeley, CA.: Lawrence Berkeley National Laboratory.
- Moore, T., Carter, D.J., & Slater, A.I. (2004). A study of opinion in offices with and without user controlled lighting. *Lighting Research and Technology*, 36(2), 131-146.
- Murdoch, J.B. (1994). *Illumination Engineering: From Edison's Lamp to the Laser*. York, PA: Visions Communications.
- Nagelkerke, N.J.D. (1991). A note on a general definition of the coefficient of determination. *Biometrika*, 78(3), 691-692.
- Nevins, R.G., Rohles, Jr., F.H., Springer, W.E., & Feyerherm, A.M. (1966). Temperature-humidity chart for thermal comfort of seated persons. *ASHRAE Transactions*, 72(1), 283.
- Navvab, M., & Altland, G. (1997). Application of CIE glare index for daylighting evaluation. *Journal of the Illuminating Engineering Society*, 115-128.
- Nazzal, A.A., & Chutarat, A. (2001). A new daylight glare evaluation method: A comparison of the existing glare index and the proposed method and an exploration of daylighting control strategies. *Architectural Science Review*, 44(1), 71-83.
- Nazzal, A. A. (2001). A new daylight glare evaluation method: Introduction of the monitoring protocol and calculation method. *Energy and Buildings*, 3, 257-265.
- Nicol, J.F. (2001). Characterizing occupant behavior in buildings: Towards a stochastic model of occupant use of windows, lights, blinds, heater and fans. *Proceedings of the Seventh International IBPSA Conference, Rio de Janeiro, Brazil, August 13-15, 2001*, 1073-1078.
- Nicol, J.F. & Humphreys, M.A. (2002). Adaptive thermal comfort and sustainable standards for buildings. *Energy and Buildings*, 34, 563-573.
- North, V.A. (1991). *Factor Influencing Workers' Impressions of Glare in Open Offices*. Unpublished Doctoral Dissertation. University of Michigan, Ann Arbor.

- Olgyay, V. (1963). *Design with Climate: Bioclimatic approach to architectural regionalism*. Princeton, NJ: Princeton University Press.
- Oscar Faber Associates (1992). *Occupancy Data for Thermal Calculations in Non-Domestic Buildings*. Building Research Establishment (BRD) Contract: F3/31158.
- Osterhaus, W.K.E. (1998). Brightness as a reliable and simple indicator for discomfort glare from large area glare sources. In International Commission on Illumination (CIE), *The First CIE Symposium on Lighting Quality* (pp. 113-124). Vienna, Austria: CIE.
- Osterhaus, W.K.E., & Bailey, I.L. (1992). Large area glare sources and their effect on visual discomfort and visual performance at computer workstations. *Proceedings of the 1992 IEEE Industry Applications Society Annual Meeting: Vol. II*. Houston, Texas: 1825-1829.
- Ozisik, N. & Schutrum, L.F. (1960). Solar heat gain factors for windows with drapes. *ASHRAE Transaction*, 66, 228.
- Paciuk, M. (1989). *The role of Personal Control of the Environment in Thermal Comfort and Satisfaction at the Workplace*. Unpublished Doctoral Dissertation. University of Wisconsin, Milwaukee.
- Palmer, S.E.(1999). *Vision science: Photons to phenomenology*. Cambridge, MA: MIT Press.
- Pampel, F. C. (2000). *Logistic regression: A primer*. Thousand Oaks, CA: Sage.
- Pan, W. (2001). Akaike's Information Criterion in Generalized Estimating Equations. *Biometrics*, 57, 120-125.
- Papamichael, K., & Beltran, L. (1993). Simulating the daylight performance of fenestration systems and spaces of arbitrary complexity: The IDC method (LBL Report 33945) *Proceedings of the Third International Conference of the International Building Performance Simulation Association*, Adelaide, Australia: 509-515.
- Park, C.-S., Augenbroe, G., Sadegh, N., Thitisawat, M., & Messadi, T. (2004). Real-time optimization of a double-skin facade based on lumped modeling and occupant preference. *Building and Environment*, 39, 939-948.
- Pellerin, N., A. Deschuyteneer, et al. (2003). Local thermal unpleasantness and discomfort prediction in the vicinity of thermoneutrality. *The 5th International Meeting on Thermal Manikin and Modeling*. Centre d'Etudes de Physiologie Appliquee, Strasbourg, France, September 29 – 30. Cited in Hui (2003).

- Pigg, S., Eilers, M., & Reed, J. (1996). Behavioral aspects of lighting and occupancy sensors in private offices: A case study of a university office building. *Proceedings of the 1999 ACEEE Summer Study on Energy Efficiency in Buildings: Vol. 8*, 8.161-8.171.
- Poulton, K. (1991). Fundamental of discomfort glare. *Proceedings of the First International Symposium on Glare*, Orlando, FL, October 24-25, 1991. New York: Lighting Research Institute, 33-54.
- Raja, I. A., Nicol, F., McCartney, K.J., & Humphreys, M.A. (2001). Thermal comfort: Use of controls in naturally ventilated buildings. *Energy and Buildings*, 33, 235-244.
- Rea, M. (1984). Window blind occlusion: a pilot study. *Building and Environment*, 19(2), 133-137.
- Reinhart, C.F. (2001). *Daylight availability and manual lighting control in office buildings: Simulation studies and analysis of measurement*. Ph.D. Dissertation, Technical University of Karlsruhe, Germany.
- Reinhart, C.F., & Voss, K. (2003). Monitoring manual control of electric lighting and blinds. *Lighting Research and Technologies*, 35, 243-260.
- Rheault, S., & Bilgen, E. (1990). Experimental study of full-size automated venetian blind windows. *Solar Energy*, 44(3), 157-160.
- Roche, L. (2002). Summertime performance of an automated lighting and blinds control system. *Lighting Research and Technology*, 34(1), 11-27.
- Rohles, F.H., Jr. (1973). The revised modal comfort envelope. *ASHRAE Transactions*, 79(2), 52.
- Rohles, F.H., Jr., Bennett, C.A., & Milliken, G.A. (1981). The effects of lighting, color and room décor on the thermal comfort. *ASHRAE Transaction*, 87, 511-527.
- Rohles, F.H., Jr., & Nevins, R.G. (1971). The nature of thermal comfort for sedentary man. *ASHRAE Transaction*, 77(1), 239.
- Rubin, A. I., Collins, B.L. & Tibbott, R.L. (1978). *Window blinds as a potential energy saver - A case study (NBS Building Science Series 112)*. Washington, DC: U.S. Department of Commerce, National Bureau of Standards.
- Rybczynski, W. (1986). *Home: A short history of an idea*. Harmondsworth: Penguin Books.

- Sakamoto, Y., Ishiguro, M., & Kitagawa, G. (1986). *Akaike Information Criterion Statistics*. Dordrecht: D. Reidel Publishing.
- Sander, P. A., & Collins, B.L. (1995). *Post-occupancy evaluation of the Forrestal building* (NISTIR 5591). Washington, DC: U.S. Department of Commerce.
- Schiller, G.E., Arens, E.A., Bauman, F.S., Benton, C.C., Fountain, M., & Doherty, T. (1988). A field study of thermal environments and comfort in office buildings. *ASHRAE Transactions*, 94(2), 280-308.
- Selkowitz, S.E. (2001). Integrating advanced facades into high performance buildings. *Proceedings of the Glass Processing Days Conference*.
- Siegel, S., & Castellan, N.J. (1988). *Non-Parametric Statistics for the Behavioral Sciences* (2nd Edition). New York, NY: McGraw-Hill.
- Stein, B., & Reynolds, J.S. (2000). *Mechanical and electrical equipment for buildings* (9th Ed.). New York: Wiley.
- Stephenson, D.G. (1964). *Principles of solar shading*. Retrieved November 22, 2004, from <http://irc.nrc-cnrc.gc.ca/cbd/cbd059e.html>
- Stevens, S.S. (1975). *Psychophysics: Introduction to its perceptual, neural, and social prospects*. New York, NY: Wiley.
- Stevens, S. (2001). Intelligent façades: Occupant control and satisfaction. *International Journal of Solar Energy*, 21, 147-160.
- Swets, J. A. (1988). Measuring the accuracy of diagnostic systems. *Science*, 240(4857), 1285-1293.
- Tape, T.G. (n.d.). The area under the ROC Curve in Interpreting Diagnostic Tests. Retrieved June 18, 2005, from <http://gim.unmc.edu/dxtests/ROC3.htm>
- Tiller, D. K., & Veitch, J.A. (1995). Perceived room brightness: Pilot study on the effect of luminance distribution. *Lighting Research and Technology*, 27(2), 93-101.
- Twisk, J. W. R. (2003). *Applied longitudinal data analysis for epidemiology: A practical guide*. Cambridge, UK: Cambridge University Press.
- Ullah, M. B., & Lefebvre, G. (2000). Estimation of annual energy-saving contribution of an automated blind system. *ASHRAE Transactions*, 106(2): 408-418.
- Van Wagene, R. K. (1990). *Writing a thesis: Substance and style*. Englewood Cliffs, NJ: Prentice Hall.

- Vartiainen, E., Peippo, K., & Lund, P. (1999). Daylight optimization of multifunctional solar facades. *Solar Energy*, 68, 223.
- Velds, M. (1999). *Assessment of Lighting Quality in Office Rooms with Daylighting Systems*. Doctoral Dissertation, Delft University of Technology: 209.
- Velds, M. (2002). User acceptance studies to evaluate discomfort glare in daylit rooms. *Solar Energy*, 73(2), 95-103.
- Vine, E., Lee, E. S., Clear, R., DiBartolomeo, D., & Selkowitz, S. E. (1998). Office worker response to an automated venetian blind and electric lighting system: a pilot study. *Energy and Building*, 28, 205-218.
- Viracon Inc. (2002). *Viracon: Performance Data*. Retrieved February 14, 2003, from <http://www.viracon.com>
- Vogt, W.P. (1999). *Dictionary of statistics & methodology: A nontechnical guide for the social sciences*. Thousand Oaks, CA: Sage.
- Vos, J. J. (2003). Reflections on Glare. *Lighting Research and Technology*, 35(2), 163-176.
- Waters, C.E. (1993). *Discomfort Glare from Sources of Non-Uniform Luminance*. Unpublished Ph.D. Dissertation, Department of Architectural Engineering, Pennsylvania State University.
- Waters, C.E., Mistrick, R.G., & Bernecker, C.A. (1995). Discomfort glare from sources of non-uniform luminance. *Journal of Illuminating Engineering Society*, 24, 73-85.
- Yamazaki, K., Nomoto, S., Yokota, Y., & Murai T. (1998). The effect of temperature, light, and sound on perceived work environment. *ASHRAE Transaction*, 104(1A), 711-720.
- Zagreus, L. (personal communication, April 5, 2005).
- Zagreus, L., Huizenga, C., Arens, E.A. (2004, June). *A web-based POE tool for measuring indoor environmental quality*. Paper presented at Closing the Loop: Post-Occupancy Evaluation the Next Steps, Windsor, UK.

**APPENDIX A: APPROVAL LETTER OF THE COMMITTEE FOR
PROTECTION OF HUMAN SUBJECTS: EXEMPTED PROTOCOL**

UNIVERSITY OF CALIFORNIA, BERKELEY

BERKELEY • DAVIS • IRVINE • LOS ANGELES • RIVERSIDE • SAN DIEGO • SAN FRANCISCO



SANTA BARBARA • SANTA CRUZ

OFFICE FOR PROTECTION
OF HUMAN SUBJECTS
101 WHEELER HALL, MC: #1340
BERKELEY, CA 94720-1340

(510) 642-7461 FAX: (510) 643-6272

Web Site: <http://cphs.berkeley.edu>
FWA#00006252

January 29, 2004

VORAPAT INKAROJIRIT (vorapat@berkeley.edu)
2110 Kittredge Street, #207
Berkeley, CA 94704

RE: "Occupants' Control of Window Blinds in Private Offices: A Pilot Study" - Dissertation Research -
School of Architecture

We have received your request of January 21, 2004, to make changes to your research protocol in the project referred to above. Since these changes do not substantially change the risks to subjects, you have our approval.

The study remains exempt and the project number remains 2002-11-42. Please continue to refer to this number in all future correspondence about the project.

If you have any questions about this matter, please contact Beth Mistretta of the CPHS staff at 642-7462, FAX 643-6272; Email bluemist@uclink.berkeley.edu.

A handwritten signature in black ink that reads "Jane Gilbert Mauldon".

Jane Gilbert Mauldon
Chair, Committee for Protection of Human Subjects
Associate Professor, Goldman School of Public Policy

JGM:mbm
Cc: Professor Charles Benton (crisp@socrates.berkeley.edu)
CPHS Agenda

**APPENDIX B: APPROVAL LETTER OF THE COMMITTEE FOR
PROTECTION OF HUMAN SUBJECTS: REVISED PROTOCOL**

UNIVERSITY OF CALIFORNIA, BERKELEY

BERKELEY • DAVIS • IRVINE • LOS ANGELES • RIVERSIDE • SAN DIEGO • SAN FRANCISCO



SANTA BARBARA • SANTA CRUZ

OFFICE FOR PROTECTION
OF HUMAN SUBJECTS
101 WHEELER HALL, MC: #1340
BERKELEY, CA 94720-1340

(510) 642-7461 FAX: (510) 643-6272

Web Site: <http://cphs.berkeley.edu>
FWA#00006252

October 20, 2004

VORAPAT INKAROJRIT (vorapat@berkeley.edu)
2110 Kittredge St. #207
Berkeley, CA 94704

RE: "Occupants' Control of Window Blinds in Private Offices" - Graduate Research - UC Energy Institute - Architecture

The project referred to above was granted approval in an expedited manner by the Committee for Protection of Human Subjects. This project met the criteria for expedited review under categories # 6 & 7.

The number of this approval is 2004-10-37. Please refer to this number in all future correspondence.

The expiration date is October 14, 2005. Approximately six weeks before the expiration date, we will send you a continuation/renewal request form. Please fill out the form and return it to the Committee according to the instructions. If you do not receive these forms in a timely manner, please contact the CPHS Office at (510) 642-7461, or visit our website at <http://cphs.berkeley.edu>.

Please note that even though the Committee has approved your project, you must bring promptly to our attention any changes in the design or conduct of your research that affect human subjects. If any of your subjects experience any untoward events in the course of this research, you must inform the Committee within ten (10) working days.

Please use the consent materials reviewed by the Committee (issued to you directly at the OPHS Office); the expiration date of the Committee's review of this form is noted in the bottom right hand corner. Please copy and use this stamped consent form for the coming year, and destroy any unsigned, out of date consent forms in your file.

If you have any questions about this matter, please contact Beth Mistretta of the CPHS staff at 642-7462; FAX 643-6272; E-mail: bluemist@uclink.berkeley.edu.

A handwritten signature in black ink that reads "Jane Gilbert Mauldon".

Jane Gilbert Mauldon
Chair, Committee for Protection of Human Subjects
Associate Professor, Goldman School of Public Policy

JGM:mbm

Cc: Professor CHARLES BENTON (crisp@socrates.berkeley.edu)
Graduate Assistant
Graduate Division (SID #14573368)
Chris Byrne/LBNL (cebyrne@lbl.gov)
Roslyn K/SPO (roslynk@berkeley.edu)

APPENDIX C: WINDOW BLIND USAGE SURVEY - GENERAL

Below is a copy of the window blind usage survey in paper format. The questions in the web-based version were nearly identical to the paper-based version. The differences between two versions are primarily due to the ‘branching’ capability of the web-based survey as well as the overall appearance. The term ‘shade’ was used instead of ‘blind’ because it was expected that the survey would be distributed to the general population, in which Venetian blind might not be the shading system that was installed in population offices.

WINDOW SHADE USAGE SURVEY

By

Vorapat Inkarojrit

Ph.D. Candidate

Department of Architecture

University of California, Berkeley

Tel. (510) 486-5002 (w)

Email: vorapat@berkeley.edu

INSTRUCTION

As part of this project, we would like you to answer the questions in this questionnaire. If there is any question you are unable to answer or do not want to answer, just skip it and go on to the next one. Try to answer all the questions based on your immediate impression. There are no right or wrong answers; it is only your opinions that are important.

There are two ways to answer the questions in this survey.

- Please mark **X** on appropriate answer, and
- Mark **X** on the scale provided, and

If there is any question that is not applicable to you, please mark **X** under the “N/A” box

The following are examples that show how each of the different questions should be answered.

EX1) What is your gender?

Male

Female

EX2) When you perform your work tasks, what is your preferred overall temperature in your workspace?

	Cold	Cool	Slightly cool	Moderate	Slightly warm	Warm	Hot	
	1	2	3	4	5	6	7	N/A
Temperature	<input type="checkbox"/>	<input type="checkbox"/>	<input type="checkbox"/>	<input checked="" type="checkbox"/>	<input type="checkbox"/>	<input type="checkbox"/>	<input type="checkbox"/>	<input type="checkbox"/>

Please turn the page when you are ready to begin the questionnaire.

PART A: BACKGROUND INFORMATION

A1) What is your gender?

- Male
- Female

A2) How old are you?

- Under 20
- 20-29
- 30-39
- 40-49
- 50-59
- 60 and over

A3) What is the type of office/workspace that you currently occupy?

- Private office
- Shared office (2-4 people share this office)
- Open-plan office

**A4) What are the primary work activities that you perform at your workspace?
(check all that apply)**

- Performing computer related task
- Reading and writing
- Interviewing and/or using telephone
- Other. Please specify _____

A5) When you perform work activities, what is your relationship with the window in your workplace? (Please refer to the orientation specified in the plan view diagram of the workspace below)

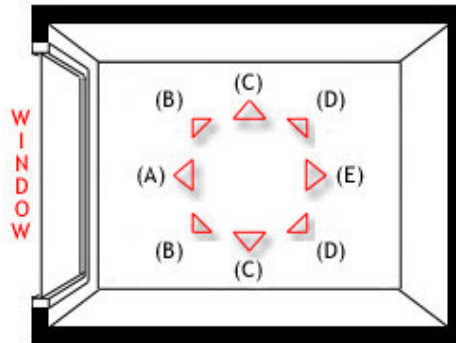

- I face the window directly
- I face partial window and wall (window corner)
- I face sidewall (window is to my left or right)
- I face back wall corner
- I face back wall (window is at my back)

A6) Which way does your window face? If you have corner office, please specify both orientations in the box provided below.

- North
- Northeast
- East
- Southeast
- South
- Southwest
- West
- Northwest
- Other. Please specify _____

A7) When you perform your work tasks, what is your preferred light level in your workspace?

- | | | | | | | | | |
|--------------------------|--------------------------|--------------------------|--------------------------|--------------------------|--------------------------|--------------------------|--------------------------|--------|
| Very | | | | Moderate | | | | Very |
| Low | | | | | | | | Bright |
| 1 | 2 | 3 | 4 | 5 | 6 | 7 | | |
| <input type="checkbox"/> | <input type="checkbox"/> | <input type="checkbox"/> | <input type="checkbox"/> | <input type="checkbox"/> | <input type="checkbox"/> | <input type="checkbox"/> | <input type="checkbox"/> | |

A8) Please rate the level of satisfaction with your view.

Very Satisfied			Moderate			Very Dissatisfied
1	2	3	4	5	6	7
[]	[]	[]	[]	[]	[]	[]

A9) The items below are meant to represent potentially negative attributes of your window view. What is the negative attribute that applies to your current window view? (check all that apply)

- I do not have a pleasant view.
- My view is too bright.
- My view is too dark.
- There are too many visual stimuli outside my window.
- I need more privacy. People can see into my office from the outside.
- Other. Please specify _____

A10) What type of glass do you have in your workspace?

- Clear glass
- Light-tinted glass (or glass with light-tinted window film)
- Dark-tinted glass (or glass with dark-tinted window film)
- Highly reflective glass (or glass with reflecting window film)
- Other. Please specify _____

A11) Do you have any exterior shading element (overhang, fin, louvers, or vegetation) that can effectively block unwanted daylight/sunlight at your workspace?

- Yes
- No

A12) What type of ventilation system do you have in your workspace?

- Air-conditioned
- Natural ventilation or Mixed-mode ventilation through operable windows

PART B: WINDOW SHADE USAGE

B1) Do you have control over your window shade?

- Yes
- No (*If you answer is NO, please go to question C1*)

B2) What type of window shade system do you have in your workspace? (If your answer is venetian blinds, please answer question 15-16, if else, please go to question 17)

- Venetian blind (i.e. horizontal blind)
- Window shade/roller shade (i.e. fabric shade)
- Vertical blind
- Drape
- Other. Please specify _____

B3) If you have venetian blind installed at your workspace, how often do you adjust the slat angle of the venetian blind?

- I rarely adjust the slat angle of venetian blind
- Once per day
- Occasionally (2-3 times per day)
- Often (more than 3 times per day)

B4) If you have venetian blind installed at your workspace, what are the primary reasons for adjusting your venetian blind slat angle?

- To increase the level of daylight in workspace
- To reduce glare/brightness from daylight/sunlight
- To feel the warmth of the sun
- To reduce the heat from the sun
- To maintain visual contact to the outside
- To increase visual privacy
- To increase room spaciousness
- To decrease the level of visual stimulus from the outside
- Other. Please specify_____

B5) On average, how often do you adjust your interior shade on a SUNNY day?

- I rarely adjust my shade on a sunny day.
- Once per day
- Occasionally (2-3 times per day)
- Often (more than 3 times per day)

B6) On average, how often do you adjust your interior shade on a CLOUDY/FOGGY day?

- I rarely adjust my shade on a sunny day.
- Once per day
- Occasionally (2-3 times per day)
- Often (more than 3 times per day)

B7) What are the top two reasons for opening/raising your window shade?

- To increase the level of light/daylight in workspace
- To feel the warmth of the sun
- To maintain visual contact to the outside
- To increase room spaciousness
- Other, Please specify _____

B8) What are the top two reasons for closing/lowering your window shade?

- To reduce the overall brightness of workspace
- To reduce the reflected glare on computer screen
- To reduce the heat from the sun
- To increase visual privacy
- To decrease the level of visual stimulus from the outside
- Other. Please specify _____

For each window blind opening and closing reasons that were chosen in question B7 and B8, the following branching questions were asked subsequently.

BX1) Are there any particular times of day when you open/close your window shade? (check all that apply)

- Beginning of day
- During morning
- Before lunch
- During lunchtime
- After lunch
- During afternoon
- End of Day
- Other. Please specify _____

BX2) When you open/close your window shade, what is the approximate position of your window shade?

- Window shade is fully opened
- Window shade is 75% opened
- Window shade is 50% opened
- Window shade is 25% opened
- Window shade is fully closed

PART C: SATISFACTION WITH OVERALL ENVIRONMENT

C1) Please rate the level of the overall satisfaction with your window shade system.

Very Satisfied			Moderate			Very Dissatisfied
1	2	3	4	5	6	7
[]	[]	[]	[]	[]	[]	[]

C2) How satisfied are you with the amount of light in your workspace?

Very Satisfied			Moderate			Very Dissatisfied
1	2	3	4	5	6	7
[]	[]	[]	[]	[]	[]	[]

C3) How satisfied are you with the visual comfort of the lighting (e.g., glare, reflections, contrast)?

Very Satisfied			Moderate			Very Dissatisfied
1	2	3	4	5	6	7
[]	[]	[]	[]	[]	[]	[]

C4) When you perform your work tasks, what is your preferred light level in your workspace?

Very Low	Low	Moderate	Bright	Very Bright
1	2	3	4	5
[]	[]	[]	[]	[]

C5) The items below are meant to represent potential negative attributes of your lighting environment. What is the attribute that applies to your current lighting environment in your current workspace? (check all that apply)

- Too dark
- Too bright
- Computer screen glare
- Too much daylight
- Too much electric light
- Not enough daylight
- Not enough electric light
- No task lighting
- No control over ceiling light
- Unpleasant colors of light
- Other. Please specify _____

C6) How satisfied are you with the temperature in your workspace?

Very Satisfied			Moderate			Very Dissatisfied
1	2	3	4	5	6	7
[]	[]	[]	[]	[]	[]	[]

C7) The items below are meant to represent potential negative attributes of your thermal environment . What is the attribute that applies to your current thermal environment in your current workspace? (check all that apply)

- Too hot
- Too cold
- Too dry
- Too humid
- Too drafty
- Too much air velocity
- Too stuffy
- No control over thermostats
- Temperature shifts too frequent
- Other. Please specify _____

C8) If an automated/intelligent shade system was available to you, would you like to have it installed at your workspace?

- Yes.
- No.

C9) Please add any additional comments about your personal workspace and/or any window shade usage issues that are not covered in this survey in the space provided below.

Thank you for participating in this Window Shade Survey.

APPENDIX D: WINDOW BLIND USAGE SURVEY - REPEATED SURVEY

Below is a copy of the window blind usage survey – repeated survey in paper format. This version of the survey was used during the passive observation period in the field study in which participants were asked to fill in the survey at least twice per day, preferably, once in the morning and once in the afternoon.

1) Please assign a rating from -3 to 3 with the following lighting/temperature condition at your workspace.

	Cold	Cool	Slightly cool	Neutral	Slightly warm	Warm	Hot	
	-3	-2	-1	0	1	2	3	N/A
Temperature	[]	[]	[]	[]	[]	[]	[]	[]
	Very dim	Dim	Slightly dim	Neutral	Slightly bright	Bright	Very bright	
	-3	-2	-1	0	1	2	3	N/A
Overall Light Level	[]	[]	[]	[]	[]	[]	[]	[]

2) Is this thermal sensation acceptable for you?

- Yes
 No, I would like to be cooler.
 No, I would like to be warmer.

3) Is this overall light level acceptable for you?

- Yes
 No

4) Please rate the level of glare.

	Not Perceptible 1	Perceptible 2	Acceptable 3	Uncomfor table 4	Intolerab le 5	N/A
Glare from the windows	[]	[]	[]	[]	[]	[]
Glare from the wall surface behind computer screen	[]	[]	[]	[]	[]	[]

5) Did you close your window blind during the last few hours? If so, why?

- Yes
 No

5A) REASONS FOR CLOSING (please check all that apply)

- To reduce the brightness of the surfaces (window, walls, and desk)
 To reduce the direct or reflected glare on computer screen
 To reduce direct glare from sunlight (the sun shines directly in my eyes)
 To reduce the heat from the sun
 To increase visual privacy or for security reasons
 Other (please specify) _____

5B) REASONS FOR OPENING (please check all that apply)

- To increase the level of light/daylight in workspace
 To feel the warmth of the sun
 To maintain visual contact to the outside
 To increase room spaciousness
 Other, Please specify _____

APPENDIX E: WINDOW USAGE SURVEY – REAL-TIME ASSESSMENT OF VISUAL AND THERMAL COMFORT

Below is a copy of the window blind usage survey – real-time assessment of visual and thermal comfort in paper format. This version of the survey was used on day five of the field study in which participants were asked to fill in the survey twice during each office visit, before and after the window blinds were opened for the assessment of visual and thermal comfort.

Before the window blinds were opened condition

A1) Please assign a rating from -3 to 3 with the following lighting/temperature condition at your workspace.

	Cold	Cool	Slightly cool	Neutral	Slightly warm	Warm	Hot	
	-3	-2	-1	0	1	2	3	N/A
Temperature	[]	[]	[]	[]	[]	[]	[]	[]
	Very dim	Dim	Slightly dim	Neutral	Slightly bright	Bright	Very bright	
	-3	-2	-1	0	1	2	3	N/A
Overall Light Level	[]	[]	[]	[]	[]	[]	[]	[]

A2) Is this thermal sensation acceptable for you?

- Yes
- No, I would like to be cooler.
- No, I would like to be warmer.

A3) Is this overall light level acceptable for you?

- Yes
- No

A4) Please rate the level of glare.

	Not Perceptible 1	Perceptible 2	Acceptable 3	Uncomfor table 4	Intolerab le 5	N/A
Glare from the windows	[]	[]	[]	[]	[]	[]
Glare from the wall surface behind computer screen	[]	[]	[]	[]	[]	[]

After the window blinds were fully opened

B1) Please assign a rating from -3 to 3 with the following lighting/temperature condition at your workspace.

	Cold	Cool	Slightly cool	Neutral	Slightly warm	Warm	Hot	
	-3	-2	-1	0	1	2	3	N/A
Temperature	[]	[]	[]	[]	[]	[]	[]	[]
	Very dim	Dim	Slightly dim	Neutral	Slightly bright	Bright	Very bright	
	-3	-2	-1	0	1	2	3	N/A
Overall Light Level	[]	[]	[]	[]	[]	[]	[]	[]

B2) Is this thermal sensation acceptable for you?

- Yes
 No, I would like to be cooler.
 No, I would like to be warmer.

B3) Is this overall light level acceptable for you?

- Yes
 No

B4) Please rate the level of glare.

	Not Perceptible 1	Perceptible 2	Acceptable 3	Uncomfor table 4	Intolerab le 5	N/A
Glare from the windows	[]	[]	[]	[]	[]	[]
Glare from the wall surface behind computer screen	[]	[]	[]	[]	[]	[]

**B5) With window blind fully open, would you like to lower your window blind?
If yes, why?**

- Yes
 No

B6) What are you reasons for closing window blinds? (Please check all that apply)

- To reduce the brightness of the surfaces (window, walls, and desk)
 To reduce the direct or reflected glare on computer screen
 To reduce direct glare from sunlight (the sun shines directly in my eyes)
 To reduce the heat from the sun
 To increase visual privacy or for security reasons
 Other (please specify)_____

APPENDIX F: WINDOW USAGE SURVEY – EXIT SURVEY

The following questions were asked after the last visual and thermal comfort assessment session of the field study. The questions include self-reported sensitivity to brightness, usability of the study, and overall experience with the experiment.

Please assign a rating from 1 to 7 for your sensitivity to the following items, with 1 being not sensitive, 3 being moderately sensitive, and 7 being very sensitive.

	Rating							N/A
	Least sensitive		Moderately sensitive			Most sensitive		
	1	2	3	4	5	6	7	
Glare	[]	[]	[]	[]	[]	[]	[]	[]
Temperature	[]	[]	[]	[]	[]	[]	[]	[]
Noise	[]	[]	[]	[]	[]	[]	[]	[]
Visual distraction	[]	[]	[]	[]	[]	[]	[]	[]

QUESTIONNAIRE USABILITY & RESEARCH PROCEDURE

Please help us improve the questionnaire and research protocol by giving your comments and suggestions in the following categories:

- Overall Experience
- Questionnaire usability (issues that were not address in the questionnaire, understanding of questions, etc.)
- Experiment procedure

APPENDIX F: OPINIONS ON AN IDEAL AUTOMATED/INTELLIGENT WINDOW BLIND SYSTEM

Below are the unedited responses to the last question of the window blind usage survey (Appendix C) which asked: If an automated/intelligent window shading system was available to you, what are the features that you would expect from an ideal automated/intelligent window shading system? (For example, think about the user interface features - how do you want the shade to be controlled, how it affects the view, etc.)

- Most important is to monitor the amount of natural light such that it creates a warm atmosphere but does not create glare. lighting that is indirect but natural is preferred.
- A knob that I can control to let a particular amount of light in.
- Allow bright light without causing glare
- Remote control Light-Dark options Color options Screen option Transparent shades with various patters Timer (i.e. on, off, up , down, etc.)
- I don't know much about the interface options.... My main goal would be to maximize daylight and visibility to the outside while minimizing the glare on my computer monitor.
- Should try to equalize the apparent brightness of the room at all times of day, esp. the glare on the computer screen.
- Auto adjust to the shade into the room. If there is too much glare then to sell adjust. If there is not enough light in the room, to shelf adjust.
- Keep shade open during the day, except when daylight will produce glare or make the room too hot. Close shade at night for privacy. It should be possible for the user to set a policy like this.

- I can't see how it would work for multi-person offices, if it isn't combined with per-desk control of lighting via spotlights.
- The shade should detect direct sunlight and lower itself just enough to eliminate glare, especially into people's eyes. (Glare on the computer screen is a secondary problem, not the big one.)
- Clap to open/close etc. or voice activated.
- Glare protection based on amount of light coming through window. I would want it to go up once the direct light has passed.
- It would be really cool if it simply learned to anticipate what I wanted to do with the shade. Otherwise, I'd like it to be designed so that, without too much work from me, it would automatically keep open as far as possible without getting too much glare or direct sunlight. A simple dial to adjust the level of glare/direct sunlight to be allowed might be good.
- For me, computer work is very important. something that could sense / deal with glare would be important.
- Not sure
- No user intervention needed
- Timed or sensitive to direct light, so that it would close to avoid light in my eyes but open in the afternoon/end of the day.
- Ability to easily raise and lower the shade. It would also be nice to be able to raise and lower the bottom part of the shade as well as the top part. That would let us see the sky while still blocking the sun (it is a south facing window).
- Programmable based on predicted glare. I think my officemates and I all prefer open shades (even if we're just staring at the side of Etcheverry), but we usually block most of the light in order to reduce glare on the monitors.
- Degree of screening (for example, block 20% of light or 50% of it).
- It should allow me to set my preferred level of light in the room and automatically open or close the shade to maintain that level. A time-based system would not be as good, since my big problem is glare, and that varies throughout the year. It should have multiple lighting sensors that I could place where the lighting conditions were most critical. The sensors should be wireless. Perhaps it could be integrated with the lighting system so that the shades and lights worked in concert to maintain optimal lighting conditions.

- I'm sharing one big window with my co-worker and our cubicles are separated by a panel, so it's inconvenient for me to open and close the blind on my side. It would be great if I can just open the corner of the blind on my side.
- I would like the shade system used manually and automatically. Because I have no set times for meetings that required privacy. I would like it automatic based on the lighting from the outside world.
- I don't care about the view, I'm at work to work. If I needed to think about something before I coded it and wanted to look out the window while I thought, it would be nice to be able to raise the shade, but staring at the ceiling works too. I'm also not too concerned about the UI. I assume that it can't be too complicated, and even if it is, I can figure it out. I would likely just put it in one position and leave it there most of the time. The worry I have is that multiple people get light from the windows and have different desires about the amount of light and the view.
- I would like the shade fully open unless there is direct sunlight/glare. Perhaps mecho shades would be better than blinds. It provides glare control without blocking out all the vision.
- Automatic ... with user override It should change based on the amount of light
- Controlled via how much light is let through and how it keeps the room temperature consistent.
- Reliability User friendly
- Programed to block direct sunlight, otherwise maximize visibility and light (not quite the same, works best with a slight upward tilt to increase light and keep a view).
- It should be programmable to meet my needs.
- Operable from chair/desk. ergonomic ease. minimal(time)interruption. maximum ambient light while minimum glare.
- Control amount of light entering room
- Control glare on computer monitor
- Soften direct sunlight
- To block out strong sunlight and reduce heat, to allow enough light to come in. To be able to override the system if I want more or less light or more or less view.

- I wouldn't want it to affect the view out, but if it could filter the sun slightly on extremely bright days and not shade at all on overcast days, that would be great.
- There is no view from above so the optimal qualities would be ease of closing for those who don't like the light--now a roller shade does that job but it is manual operation
- I would only like the system if I was able to override it... for example, open the shades even though it might be too bright, etc. The electrical lighting is very poor, and I really appreciate being able to control my view/natural lighting.
- Keep the sun out of my eyes
- One where I could adjust the controls to the various and changing conditions.
- No worry about the view. Would like to have automated system adjust to amount of light coming through the window. Automatically let less light in during the morning, a bit more during the afternoon. Compliment with dim office lighting.
- The system should adjust to external atmospheric conditions whether it is too sunny or cloudy causing it to be too bright or too dark inside and adjust to external temperatures causing it to be too warm or too cold inside.
- Not a window expert, hard to articulate what I would. Perhaps the blind should be able to sense brightness and darkness at certain level and adjust itself.
- I do not know what an automatic / intelligent shade is
- In the early morning, when the sun shines directly into my workspace, it would be nice if either the shades automatically lowered, or if the glass was able to darken enough to cut out the the brightness (kinda like the eyeglasses that were popular in the '80s, that lightened/darkened depending on the enviroment the wearer was in).
- Manual over-ride, light-sensitive
- Something to filter out the sun glare.
- View is not an issue for me, as I am at work. I would want it to provide complete coverage of the window area when needed, adjusting to control temperature based on uv/heat. Perhaps an internal thermostat that would activate a sill mounted exhaust fan to remove excessive heat.
- I like the idea of installing a window shading system w/manual. I would like to be able to adjust the shades according to the amount of sunlight and/or temperature.

- The only time I don't like the shades open is in the morning when the sun is shining directly on the computer screen. An ideal system would be able to tell when the sun is past my screen and then open.
- I can see windows about 20 feet away which shows sun only in the a.m. The windows come from the ceiling down about 3 feet. I would like to see more of the outside and have more natural light.
- Close completely to cut glare. Open smoothly on command. It's difficult to close the open venetian blinds. They are too light weight and do not fall.
- Programmable to adjust automatically based on a temperature and/or brightness factor that the user could input when first set-up
- Right now I have blinds which I never/rarely touch. I'm always open to new innovative technologies which may improve my working environment. I would probably keep these shades just like I have the blinds - unobstructing my views and slightly higher than my head when I'm sitting in my chair.
- Some automatic but some user-controlled functions Not too dark, ability to block direct sunlight but still allow natural light in,
- Not sure
- Decrease glare in the room but bring in light, decrease heat but use passive solar to heat when temperature is low. I have no ventilation in the room, so exterior air is all. View is excellent and outdoor feeling helps the office.
- I would have to use it at the large window behind my desk, which is located between my workspace and another office (with windows facing the street side of the building). Naturally, a motorized system with complete control of the amount of light filtered through would be ideal, but probably too costly.
- If the system is automated, I would like to have the ability to override the system for manual adjustments. Remote control would be nice. It would be great if the shade automatically and continuously opened throughout the day for maximum light and openness, without causing glare on the computer screen. The shade should have better coverage than my existing vertical blinds, so light can't peek through and reflect on my computer screen. If the blinds were installed on tracks and made of sturdy material, it probably wouldn't make noise and blow around as much from the wind, allowing me to open the blinds for better ventilation, cooling and openness. An ideal window shading system would be quiet and undistruptive or distracting.
- Shade control by remote, having settings so that when the direct sun hits the window the shade moves to block the sun but keep a view of outside, or when it

becomes cloudy to open the blind at a certain degree of darkness. Most venetian blinds have the wands to control the slats but the wand is often not easily accessible.

- Well, I don't know much about automated/intelligent window shading, but in my imagination mine would respond to temperature (open when below a designated temp; close when above), yet with the ability to be manually operated if a change in view is desired.
- To control how much direct sun comes in through window, opening up if it's a cloudy or foggy day, closing if it's too bright.
- Primarily for it to be heat sensitive and to "know" when to close so it can block heat from building up as much in the office.
- I am most affected by heat and glare, so I would want it to respond to those two things, with me choosing the tolerable (or intolerable) levels)
- To control the temp and control the lighting
- As the sun moves from the east to the west, it would be great if the shading system could make an adjustment to the sun's glare so I can open the blinds and look out the widow without being blinded in the process.
- I would want it to be quiet.
- Able to be programmed based on user need. Shade could sense temp changes like a thermostat or understand needs for light at various times of the day of when in a meeting versus using the computer. Voice activated would be a big plus as well.
- I would prefer a shade screen type that would allow me to view the outside, let in light but keep the direct sunlight out.
- Personal control of light and heat; system should not block view from window. System should not take very longer to adjust the heat or light from the window.
- I want consistent temperature, brightness, and maximum view. So at 70 degrees, and moderately light I wouldn't have ANY shades! I want the shading increased as the light level increases so that a constant brightness is maintained. If the temperature at the window increases then it should factor in with the light intensity to maintain as much light without being too bright or hot.