

1969

## Basic Educational Experiences Program Utilizing Individualized Instruction in Auditory and Visual Perception Phase II

Peggy L. Stapleton  
*Central Washington University*

Follow this and additional works at: <https://digitalcommons.cwu.edu/etd>

 Part of the [Disability and Equity in Education Commons](#), [Educational Methods Commons](#), [Elementary Education and Teaching Commons](#), and the [Health and Physical Education Commons](#)

---

### Recommended Citation

Stapleton, Peggy L., "Basic Educational Experiences Program Utilizing Individualized Instruction in Auditory and Visual Perception Phase II" (1969). *All Master's Theses*. 1171.  
<https://digitalcommons.cwu.edu/etd/1171>

This Thesis is brought to you for free and open access by the Master's Theses at ScholarWorks@CWU. It has been accepted for inclusion in All Master's Theses by an authorized administrator of ScholarWorks@CWU. For more information, please contact [scholarworks@cwu.edu](mailto:scholarworks@cwu.edu).

BASIC EDUCATIONAL EXPERIENCES PROGRAM UTILIZING  
INDIVIDUALIZED INSTRUCTION IN AUDITORY  
AND VISUAL PERCEPTION  
PHASE II



A Thesis  
Presented to  
the Graduate Faculty  
Central Washington State College



In Partial Fulfillment  
of the Requirements for the Degree  
Master of Education



by  
Peggy L. Stapleton  
October , 1969

LD  
5771.31  
S8  
Spec.  
Coll.

179823

**Library**  
**Central Washington**  
**State College**  
**Ellensburg, Washington**

APPROVED FOR THE GRADUATE FACULTY

---

Dohn A. Miller, COMMITTEE CHAIRMAN

---

J. Wesley Crum

---

William D. Floyd

## TABLE OF CONTENTS

| CHAPTER   | PAGE |
|---|------|
| I. THE PROBLEM. . . . .                               | 1    |
| Need for the Study . . . . .                          | 1    |
| Purpose of the Study . . . . .                        | 2    |
| Organization of the Study. . . . .                    | 3    |
| Background Information . . . . .                      | 3    |
| Definition of Terms. . . . .                          | 5    |
| II. REVIEW OF THE LITERATURE . . . . .                | 7    |
| III. THE PROGRAM. . . . .                             | 13   |
| Introduction to the Program . . . . .                 | 13   |
| Structure of the Program . . . . .                    | 15   |
| Purposes and Guidelines . . . . .                     | 19   |
| Beginning Group Activity. . . . .                     | 20   |
| Jumpboard . . . . .                                   | 26   |
| Balance Beam. . . . .                                 | 35   |
| Eye-Hand Coordination . . . . .                       | 45   |
| Pencil-Paper Tasks and Chalkboard Activities. . . . . | 53   |
| Auditory Awareness and Discrimination . . . . .       | 60   |
| Visual Memory. . . . .                                | 66   |
| Stepping Stones. . . . .                              | 71   |
| Final Group Activity . . . . .                        | 74   |
| Experience Units . . . . .                            | 75   |
| The Circle. . . . .                                   | 76   |
| The Square. . . . .                                   | 78   |

|   |     |
|---|-----|
| The Rectangle . . . . .   | 78  |
| The Triangle . . . . .  | 80  |
| The Diamond . . . . .   | 82  |
| All Shapes . . . . .  | 86  |
| IV. PROGRAM INDIVIDUALIZED FOR STUDENT NEEDS . . . . .  | 88  |
| Characteristics of the Five Visual Perceptual<br>Abilities Relevant to Classroom Learning and<br>Suggested Training Areas . . . . . | 89  |
| Perceptual Motor Survey - An Inventory of<br>Individual Programming . . . . .   | 93  |
| V. SUMMARY, CONCLUSIONS, RECOMMENDATIONS, , . . . . .   | 94  |
| BIBLIOGRAPHY. . . . .   | 98  |
| APPENDIX A - Letter to Dr. Newell C. Kephart. . . . .   | 101 |
| APPENDIX B - Reply. . . . .   | 102 |

## ACKNOWLEDGMENTS

The writer wishes to express sincere appreciation to Dr. Dohn Miller for his valuable assistance and guidance. Appreciation is also expressed to the other two committee members, Dr. J. Wesley Crum and Dr. William Floyd.

The writer is grateful for the opportunity of exploring this field and for the encouragement in writing this paper given by Dr. Richard Mould, Executive Director of Student Personnel Services for Yakima Public Schools. Valuable assistance was also given by Mrs. Delores Brackett, perceptual consultant for Yakima Public Schools.

The deepest appreciation is expressed for the writer's family for their continued support and enthusiasm in this effort.

CHAPTER I



## CHAPTER I

### THE PROBLEM

#### Need for the Study

In 1963 statistical data in the standardization sample of over 2100 unselected nursery school and public school children tested with the Marianne Frostig Developmental Test of Visual Perception (13) showed that visual perception disturbances were common symptoms. It appeared that these symptoms contributed to learning difficulties. (14).

"Visual perception is one of the paramount psychological functions and developmental tasks of young children. Studies indicate that inadequate visual perception skills may hinder a early school success and lead to inattention, misbehavior, lack of cooperation, and generally poor adjustment in the classroom" (22:16).

At least twelve per cent of the primary children in Yakima Public Schools have been found in need of perceptual training as a result of psychological evaluations completed each year by the Student Personnel Services staff. Therefore, Phase I of a Basic Educational Experience Program (6) has been developed. It was then necessary to fit the individual needs of each child as a follow up to this program.

Phase II contained individualized sequential perceptual activities including gross and fine motor control. Experiences

designed to strengthen and extend the child to his fullest potential provided opportunities for discovery and enrichment in learning. The initial understanding of the five basic shapes as a culminative theme matched the components of the following Experience Unit areas: beginning group, jumpboard, balance beam, eye-hand coordination, pencil-paper and chalkboard tasks, auditory discrimination, visual memory, stepping stones and final group activity.

#### Purpose of the Study

The purpose of this study was to develop Phase II in the Basic Educational Experiences Program, Phase I (6) of which was already in use in Yakima's Elementary Schools. Phase I was a minimal program in motor-sensory development. Phase II was a program in sequential perceptual activities contributing to and supporting the perceptual needs of the individual child through personal involvement in its activities.

The intent was that first graders, upon completion of Phase I, who were in need of additional help would be included in Phase II. Referrals from other primary grades would benefit from its activities if adequate personnel were available to include them.

### Organization of the Study

Chapter two contains a review of the relevant literature concerned with perceptual development and its relation to the individual, his self-concept and personal success. It provides a background of information and gives purpose to the program's contents.

Chapter Three presents the program. A station-rotation program was developed and maintained within the following six Experience Units: (1) the circle, (2) the square, (3) the rectangle, (4) the triangle, (5) the diamond, and (6) culmination and recall of all five shapes.

Developmental areas within each unit are: beginning group, jumpboard, balance beam, eye-hand coordination, pencil-paper and chalkboard tasks, auditory discrimination, visual memory, stepping stones and final group activity.

The program is individualized to student needs in Chapter Four. Characteristics of the five visual perceptual abilities relevant to classroom learning, suggested training areas, and a perceptual motor survey are included.

Chapter Five summarizes and presents implications of the Phase II program.

### Background Information

According to Dr. Newell C. Kephart, in an address delivered at Seattle, March 15, 1968 to the Washington State Council for Exceptional Children, it is not until purposeful systemized

differentiation takes place that purposeful and functional response develops. From functional activities the interaction of environment is purposeful. The figure-ground relationship comes first in such areas as sorting and differentiating. A structured organism then begins to determine information, to concentrate on parts and to take masses of information and experiences.

He indicated that contact of learning to control the environment is made systematically and predictably. There is a control in the course of information while complex programming of output and input integrates information that is being gathered by the organism. Perceptual motor matching, which is watching hands correlate with visual, tactual and kinesthetic coordination or the matching of perceptual information to motor information, develops only in this order. Form constancy comes from this perceptual to motor matching.

Kephart said that then the organism is able to lay a plan, monitor its development and predict the results after this previous development has taken place. He listed in the following manner how the organism integrates:

1. Intersensory - auditory and visual information mean the same thing.
2. Sensory motor - manipulation of things and of his own body in relation to things - matching sensory data to motor data.
3. Inclusive - response to the total visual stimulation with all senses involved.

In the perceptual learning aspect Kephart related that the development of exploration with vision forms an awareness of similarity and differences making possible a single response with all elements and all elements are manipulated in their relationship.

He continued by pointing out the first approach to abstraction is in similarities and categorization of large masses of information was attributed to perceptual-conceptual learning or the last stage of learning. Here the distortions and alterations attending to perceptions are found and then the prediction of responses evolves.

In conclusion Kephart stated that, "When we teach the child with a learning disability we program the computer to responses. We create a valid model in the face of inadequate machinery and we must manipulate the model to become autogenous. The majority of our problems were with us when we were born. We must determine where the learning broke down or where the stitch was dropped."

#### Definitions of Terms

Auditory discrimination. This is hearing likenesses and differences in sounds of speech as well as in other sounds.

Cognitive. That operation of the mind by which we become aware of objects of thought or perception, including understanding and reasoning.

Directionality. The projection outside the organism of the laterality which has been developed within oneself is referred to in this way.

Self-concept. A variety of meanings were used for self-concept. The interpretation by Combs (1964) listed (a) adequacy, (b) acceptability to others, (c) acceptability of peers, (d) acceptability of adults, and (e) freedom and adequacy of emotional expression. Borislow (1962) limited self-concept as the students' conception of themselves as students. Powell (1964) used self-concept in terms of social desirability, while Watson (1965) correlates the term with self-awareness. Scott (1968) discusses maturity of self-concept, or the immaturity of it, as directly related to social and emotional success or ills.

Kinesthetic. "The sense of perception gained from the feelings created by one's own movements and bodily tensions" (25:134).

Laterality. This term is used in reference to an internal awareness of the two sides of the body and their differences.

Perception. The ability to interpret accurately objects in terms of time and space in the environment.

Station-rotation. The process of taking part in one activity at a given area, as the jumpboard, and then, at a signal, moving to the next activity area.

CHAPTER I I

## CHAPTER II

### REVIEW OF RELATED LITERATURE

This chapter contains a review of relevant literature concerned with auditory and visual perceptual development.

Visual perception does not refer to eyesight, the images focused on the retina of the eye, but to the brain's interpretation of the incoming visual stimulus. The eye sees lines and surfaces but the brain perceives them as specific objects and shapes and their relationship in space.

The tactual, visual, auditory and kinesthetic organization develop at an early age. A gap in any of these areas may cause a difficulty in the information process.

Even when children are of average or above average intelligence, they may have unaccountable difficulties with writing, reading, or motor coordination. Figures and letters may appear distorted, jumbled or confused so that keeping up with work for their grade level is most difficult.

"Five visual perceptual abilities that seem to have the greatest relevance to academic development are: (1) perception of position in space, (2) perception of spatial relationships, (3) perceptual constancy, (4) visual-motor coordination, and (5) figure-ground perception, as stated by Frostig (14:10).

The perception of position in space relates to the way in which an object is oriented and the way it looks to the observer.



Letters may be reversed or confused with other letters and in the same shape with various positions as "b", "d", "p", and "q".

Difficulty in perception of spatial relationships may make it impossible for a child to perceive the sequence of letters in a word. In attempting to solve arithmetic problems, children may be unable to remember the sequence of processes involved in mathematical or related fields. This involves the ability to perceive the position of objects in relation to each other as well as to the observer. A lag in this area has direct relationship upon learning to read, spell and achieve simple every day tasks as well as the understanding of processes in sequence.

Constancy in visual perception requires recognition of an object no matter from what angle or direction it is viewed. Children having difficulty within this area might fail to recognize a word already known if presented in a different color, size or content.

Children having difficulty in visual-motor coordination find tasks involving eye-hand movements as writing letters and numbers confusing.

Figure-ground perception is the ability to perceive an object as distinct from its surroundings. Seemingly careless children may just not be able to pick out relevant details or missing parts in a given area or may change the order of words because of a lack of development in this area.

Perceptual disturbances are hidden and often not discovered so the learning process is slowed accordingly.

Integration of language as perceptual experiences is necessary and advantageous. Preparation for reading depends upon the use of visual and auditory skills. From such experiences meaningful language usage develops. As imagery and verbal descriptions are introduced, the child's insight and realization of his part in a world of communication increases.

Accurate auditory and visual perceptual abilities enable children to undertake better recognition and reproduction of visual symbols, the major areas of school work on which achievement is based. The ability to read is foremost of these. The positive development of a skills program in visual perception will enable children to receive a good, reliable head start in learning.

In order to progress in understanding the learning processes as they are presented, children need to recognize and interpret visual stimuli by correlating them with previous experiences and to establish and maintain the organized imposition of rhythm upon auditory stimuli.

In a summary of a study by Sterrit and Rudnick (1966) it was concluded that the ability to transpose from auditory-temporal to auditory spatial patterns is related to reading in a way not fully accounted for by general intelligence.

If the potential motor abilities of children are to be developed so that a reliable and consistent body image will be realized, children having such difficulties will require a program planned for their learning process. Children's abilities to appropriately apply movements in relation to time and space available to them has a bearing on their abilities to cope with learning problems.

If they have not acquired the ability to recognize and interpret visual stimuli by correlating them with previous experiences, there is a delay in the transferring of printed or written words to the mind.

By observation of movement of parts of the body and the relationship of one part of the body to the other parts, working together or separately as the task confronted may involve, children become aware of their total body. Finding adequate space in a selected area of obstacles for movement of body parts becomes an involved task for children who do not have an accurate or well developed body image. It is often impossible for children in this case to move one part without the supporting movement of the other. The basis for good visual motor control comes from well established large motor control.

Cruickshank (1963) emphasizes that unless a child has a coordinated and coherent understanding of the body schema, learning tasks required in the classroom do not take place or are behind the expected growth pattern. The control and adjustment to the environment is dependent upon efficiency of movement.

Radler and Kephart (26:24) point out that all behavior is a kind of movement and "the movements made by a developing child constitute learning units that contribute to this total store of knowledge."

Kephart (1960) relates that a child must be able to distinguish between his right and left side and to control the two sides of his body separately and simultaneously before he can begin

a task such as drawing a square. Laterality is learned only by experimentation with the two sides of the body and their relationship of one to the other, both their similarities and differences.

According to Kephart (18:45) "The development of laterality is extremely important since it permits us to keep things straight in the world around us." He goes on to cite that the only difference between a "b" and "d" is laterality.

Laterality leads to directionality where an awareness of the right and left sides of the body can be directed into spatial relationships to the child himself and an object and then from one object to another object. Control of the eyes, matching of kinesthetic information with information from outside, and translation of the subjective directions involved in crossing the midline are directly related according to Kephart (1960).

"In order to maintain objective directions of the movement without confusion, therefore, the child must learn three procedures and learn them with extreme precision. (1) He must learn where the midline of his body is. (2) He must learn how to reverse the translation at the midline without interrupting the continuous external movement. (3) He must learn to always reverse when the midline is crossed," states Kephart (18:45).

Only through a reliable and consistent body image can the child develop a reliable and consistent point of origin for either perceptions or motor responses. From the experiences obtained in the motor area, a child develops laterality or the inner feeling or awareness in the differences in the sides of the body.

Directionality or movement into space in relationship to right and left is a requirement in environmental adjustment. With the establishment of laterality and directionality, a child is ready to cope with learning processes presented to him in school.

"Teaching should be directed toward the total activity of the child in any given task. The total activity includes all four processes: input, integration, output, and feedback," Kephart (18:64). In reinforcement to this statement he continues by insisting that the perceptual and motor processes of the child cannot be separated and teaching must meet this integration.

Barsch (3:167-168) suggests that the dynamics of perception can be answered "only with reservations and qualifications" and synthesizes 20 theorists. He concludes, "The elusive mother lode is yet obscured." He states that, "Since perception is dynamic, continuous and multiple, it becomes an impossible task to label each perception with a separate name," (3:175). He confirms a fused relationship in usage of the terms perception or cognition.

Watson (29:177) adds to this by using the two terms together as perception is "originally dependent on sensory development" and "concept is attained when he can make the appropriate response to stimuli he has not previously observed." He further states that "Perceptions and conceptions come about as a result of learning" (3:179).

As Kephart (18:55) has pointed out, "a closed system, involving a feedback control, is operative in the perceptual process."

Getman and Kane (15:56) state "No child KNOWS a line is straight or curved just because some adult says so. He KNOWS it is straight or curved when he experiences and checks it through his own machinery. The child's own ability to experience and produce an action is his real and final authority."

In further emphasis of this statement Radler and Kephart (26:25) say, "having determined the shape and limits of the world within his own skin and having related this learning to the form in the world around him, the child can move on to an awareness of the vast space outside himself."

CHAPTER III

## CHAPTER III

### THE PROGRAM

#### Introduction to the Program

The following program was designed for small group application to maximize the learning potential of children with perceptual-motor impariments on the basis of individual learning patterns. As Phase II in the Basic Educational Experiences Program it was aimed at providing motor activities and guides promoting an awareness of body parts, how they function in space and what they can do. Provisions were established for auditory and visual discrimination, visual-motor perceptual development, muscular strength and dynamic balance.

This developmental program was planned for first graders needing additional training after their involvement in the Basic Educational Experiences Program as well as second and third graders who have been identified as manifesting a perceptual dysfunction.

Children are better prepared to meet their classroom responsibilities with self-confidence that is gained by successful experiences within their area or areas of difficulty. Increasing sensory perception so that children are vitally aware of the impressions senses bring to them enhances their learning attitudes and aptitudes. The achievement of simple sensory tasks or discovering, classifying and experiencing concepts of size, shape, content, texture and movement gives strong satisfaction and prepares new contacts for learning.



The developmental sequence of the activities was based upon research, experiences and observations of children in classrooms, participating in the Basic Educational Experiences Program and in individual perceptual programs.

The following guidelines and procedures were arranged in sequential experience units. The five shapes: circle, square, triangle, rectangle and diamond were used as a culminative theme. The developmental sequence of the activities was based upon the accumulation and synthesis of related subject matter and the author's experiences in working with children involved in the learning processes.

It was planned that high school students who have been student leaders in the Basic Educational Experiences Program, Phase I, (6) would be further trained to work in Phase II activities. A team of students would be assigned to an elementary school and there to one, two or a maximum of three children specifically. An adult within the building would be available as a guidance and clearing coordinator for special needs, communication, materials and questions.

These student leaders would be involved in Phase II for one period of their school day five days a week and would be given one credit per semester in continuation with the previous program. Monday would remain a seminar day with the perceptual consultant in preparation for the Tuesday through Friday building schedule and procedures.

By limiting the number of activities in the Phase II program and by adapting those presented to each specific shape,

preparation of student leaders became more realistic and reinforcement of children's needs became more effective.

Each experience unit was designed to be used for a period of two to four weeks according to the needs of the children involved, taking into consideration the number of days in a week the program was carried out within a building and the amount of time devoted to the program each day. In an ideal situation children would receive about 40 minutes a day in Phase II activities.

Time allowance for each activity will need to be determined by the total amount of time for the daily program, the areas to be covered, the area of greatest difficulty for the individual child and his progress and success. Program procedures would be reviewed and determined by the student leader and the perceptual consultant in cooperation with the classroom teacher.

Because the program's structure is based upon individualization, a daily limitation or expectancy of achievement cannot be stated. The following plans were concerned with an over-all approach with suggested folders and boxes for each child's learning tools and worksheets, establishing a sense of security and independency.

An important aspect of the entire program was the provision for children being guided in activities where they had a part in planning and construction of the necessary materials to be used.

#### Structure of the Program

Suggested activity areas in this guide were: jumpboard, balance beam, eye-hand coordination, pencil-paper tasks, auditory,

visual memory and stepping stones with provision for a beginning total group warmup and a short total group conclusion.

Because of differences in schools, facilities and children's needs, some activities may not be as applicable to a situation, individual or group. In these instances the utilization of review in any difficult learning area or a routine particularly geared to the child's problems could be planned. Consultants would be available.

Since children would be in stocking feet for jumpboard and balance beam activities, shoe areas and a quiet return to these areas should be established before beginning the program.

The program paralleled classroom activities with emphasis on perceptual motor matching experiences, using success as a prime goal as a reinforcement to the learning and coordinating adjustment needs of a child. Supplementary activities in the classroom are encouraged whenever possible.

When several small sets of leaders and children are working in the same room, the rate of progression from one experience unit to the next may vary. All children could benefit from the introduction of the new form correlated in the beginning group activity. It would serve to stimulate interest and enthusiasm. However, since this program was designed to build self-concept and self-improvement, every effort should be made to avoid any feeling of competition between groups or individuals.

The child was provided with a shoe box with his name on it in which he could keep his learning tools, objects and shapes that

he had cut out. He also developed his own inventiveness of ways to use these shapes and materials. Thus he was readily equipped for the work that was expected of him.

A folder for his completed work as well as for future assignments helped him in projecting his thoughts to planning for work ahead as well as reviewing what he had accomplished.

### Purposes and Guidelines

In order to fully understand each activity as to intent, values and suggested methods of approach and development, a section of purposes and guidelines will be stated for the following areas:

Beginning Group Activity

Jumpboard

Balance Beam

Eye-Hand Coordination

Pencil-Paper Tasks and Chalkboard Activities

Auditory Awareness and Discrimination

Visual Memory

Stepping Stones

Final Group Activity

## BEGINNING GROUP ACTIVITY

The purpose of the beginning group activity is to develop muscular strength, dynamic balance and to provide a warm-up period to prepare the child for tasks and skills he will meet in various stations or activity areas. The child will learn to put his body into directed action while working towards more effective use of the space available. A more efficient use of locomotor body movements is presented. Total daily time for this activity should be about 5 minutes. From here children will go into their individual programs with their assigned leaders.

An opportunity to explore and to develop an awareness of self-importance within a group experience is reinforced by individual participation in closing a continual formation of the intended symbol or shape being introduced. Children begin their activities in this group by forming the intended shape as designated verbally, by visual signal or by hand signal given by the leader.

As the shape is formed, its name should be stated in realization of what is expected, as "We're forming a square". Guide lines or string, yarn or tape may be helpful in maintaining the shape. (Check with building principal before putting tape on floors.)

Talk about the shape as the line of children join to form it. Face the center of the shape, then face the outside area of the shape. To reinforce the form the following activities might be carried out over a period of several days or weeks.

1. Start walking around the shape.
2. Start hopping, first with both feet together, then on one foot around the boundaries of the shape.

3. Make yourself as small as possible and keep walking.
4. Make yourself as tall as possible and continue walking.
5. Walk with stiff knees.
6. All-four's walk - on hands and feet continuing in the formation of the shape...watching for corners in all but the circle.
7. Take giant steps.
8. Walk on tiptoe.
9. Stamp your feet as you walk.
10. Walk as though you are on a cloud.

For the first week or desired amount of time begin movements in the right side orientation. Then begin movements to the left when the right concept is realized. When right and left movements are smoothly established, combinations of the two might be carried out as: taking giant steps to the right; stop; walk as on a cloud to the left.

Further variance in movement can become more effective by changing the force with a lighter or heavier foot or hand movement emphasis as: right foot stamp; left foot soft. Some activities may be carried out by doing them with eyes closed.

## PROCEDURES AND GUIDELINES

BEGINNING GROUP ACTIVITY

The following activities might be carried out on different days following the line formation of the shape involved:

1. Toss a ball from one to the other in consecutive movement around the desired shape.
2. Ball bouncing routines, games or records for marching.
3. Rabbit hop beginning in squat position. Extend arms in front; hands on floor. Child jumps up to hands. Repeat.
4. Cat walk bending over and placing both hands on the floor. Walk softly on hands and feet like a cat.
5. March in place in an exaggerated fashion raising knees high while swinging arms freely flexed at the elbows. The right arm should be forward as the left knee is raised.
6. Lame dog placing both hands and one foot on the floor, movement is obtained by walking along on hands and hopping on the one foot. Encourage child to hold up the lame foot as high as possible. Alternate lame foot.
7. Fox and squirrel using a ball and bean bag toss procedure. A soft fleece ball works well at first.
  - a. The "fox" is the ball and the "squirrel" is the beanbag. On signal, "go" both objects are started around, the fox trying to catch the squirrel.
  - b. The fox may change direction at any time. The squirrel must change direction only to avoid being caught.



8. Beat the bunny using two balls of different sizes.
- a. The bunny (small ball) is started first and is passed from child to child around the circle or shape. When the bunny is half way around, the farmer (large ball) is started.
  - b. If the farmer catches the bunny, the farmer wins. If the bunny catches the farmer, the bunny wins.

## EXPERIENCE UNIT SIX

BEGINNING GROUP ACTIVITY

Show by symbol the desired shape the group or individual child should form as a culmination and realization of form constancy to the five shapes presented in the previous weeks' activities. Individuals may form the shape by sky writing, chalkboard writing or by walking its lines.

According to the number of children in the group, activities might include:

1. Form one line and then make a circle.
2. Form three lines and then make a triangle.
3. Form one line and then make a square.
4. Form four lines and then make a square.
5. Form four lines, two equally short and two equally long, and then make a rectangle.
6. Form two lines, one short and the other long, and then make one big circle and one little circle.

"Sky write" the shapes in various positions in relation to the body as:

1. Write a circle around your feet.
2. Write a square on the right side of your body.
3. Write a triangle in front of yourself.
4. Write a diamond high in the air.
5. Write a big circle high in the air and a little circle low by your knees.

Directions for these and other activities can be shown by visual symbol, picture or form, rather than continual verbal signal.

Pretend you're a train by forming a line of children as a working unit. Vary movements around the desired shape serving as the "track". Try speeding over the tracks, approaching a town, leaving the station or going up a hill.

Animal walks and stunts in Purpose and Guidelines for BEGINNING GROUP ACTIVITY, page 22, may be adapted following the same "tracks" as for the train.

Using the names of the shapes separated into syllables as number keys, children respond to movement activity directions:

1. Jump, both feet together and say "square" (one jump).
2. Jump, both feet together and say "rec-tan-gle" (three jumps).
3. Hop on the right foot and say "cir-cle" (two hops).
4. Bend over and tap ankles and say "tri-an-gle" (three taps).
5. Hop on the left foot backwards and say "dia-mond" (two hops).

## JUMPBOARD

The techniques for the use of the jumpboard were designed to reveal the child's knowledge of his own body and how to control its parts. During the jumpboard activities children will experience an awareness of balance and existence in the space provided for them. In order to perform at an acceptable level, the child discovers combinations of movements involved in balance thus learning visual directions of the total body. Shoes should be removed to obtain full feeling of this activity.

Before beginning any of the suggested activities: (1) determine the correct approach to the board, (2) establish the direction for leaving the board, (3) plan the return to the beginning place, (4) explain use of wall targets for the eye focal point, (5) let the child walk across the boards to get the feel of them, and (6) practice using the rug at the beginning and end of the board as a signal for starting and stopping activities.

Eye targets should be placed within easy viewing of all children. They can be constructed from brightly colored paper and should be from ten to fourteen inches in size. Shape, color, size and content of the targets, that is numbers or letters that may be put on them, should be changed frequently increasing visual awareness. Responsibility for making these targets could be a most valuable activity for the eye-hand coordination tasks.

Whenever possible boards should be faced at various positions within the room such as to the east one day and the west another.

Boards may be placed to form the shape of a square or triangle when those shapes are the unit experience. The child should also begin activities at opposite ends of the boards.

Activities for the board are presented in the same sequence as in the BEEP, (Basic Educational Experience Program), (6) and each set was intended for one week's time in that program. Allow enough time for the child to progress at his own speed in Phase II since the intent is to fit each child's program, not that of a group.

Directions for jumpboard construction are found on page 34. The leader or child should first demonstrate an activity. Establish eye targets in front, behind, at the left and right before beginning.

1. a. Jump across the board in small jumps, both feet together, forward to the opposite end of the board. Watch the eye targets.
- b. Jump with both feet together backward to the opposite end of the board.
- c. Eyes closed. Jump forward across the board, feet feeling the rug for beginning and ending.
- d. Eyes closed. Jump backward across the board.
- e. Jump three jumps, both feet together, forward; two backward, and then forward to the end of the board. Any combination of jumps may be designated by the leader. Claps from the leader may regulate jump pattern. Hand signals for forward and backward directions encourage self response.
- f. Have children jump as high as they can go.

2. a. Locate the center of the board with children. Jump both feet together (small jumps) to the center of the board, turn completely around by jumping both feet together in quarter turns. Continue jumping forward to the end of the board. Use signals to designate turns such as big circle, green circle, little circle, red circle, big circle.
  - b. Repeat pattern by starting the jumps backward, turn in the center in complete turn and continue to opposite end jumping backward.
  - c. Repeat forward and backward patterns above with eyes closed.
  - d. Do jumping jacks at the center of the board after a quarter turn has been made so ample foot spread is possible.
3. a. Both feet together, jump to the middle of the board, jump forward and backward staying in the center. Jump to the end of the board.
  - b. Repeat starting with backward jump from the beginning of the board.
  - c. Both feet together, jump vertically (small jumps) to the middle of the board, turn one quarter turn to be horizontal with the board. Child holds arms out, jumps sideways right and left staying in the center of the board. (Leader clapping or beating drum to keep jumps together is helpful.) Turn, jump both feet together to the end of the board.

- d. Repeat above starting backwards and jumping to the center.
  - e. Repeat "c" and "d" with eyes closed.
  - f. Review jumping jacks.
- 4.
- a. Jump small jumps to the center of the board, both feet together, right arm extended. Jump quarter turns using "right" as well as the name of the right designated eye target name for direction on jumps.
  - b. Repeat starting backward, still emphasizing "right".
  - c. Pendulum swing: Jump, both feet together, forward to the center of the board. Hop on left foot while swinging right leg and arm forward and backward. Then jump, both feet together, to the end of the board.
  - d. Hop, right foot, forward and backward, number of hops determined by leader's direction. Again, using numbers on cards or fingers to show number of hops along with words or hand signals for forward and backward direction, the auditory signal is matched to a visual stimulus.
  - e. Repeat "a", "b", "c", or "d" with eyes closed reinforcing right in directionality.
- 5.
- a. Hop across board, hopping on right foot only, right hand over head. The right side might be marked in various manners as to reinforce the side intended. Some methods of marking might be rolling up the right

- sleeve or pantleg, putting a clothes pin on the right sock, holding a ball or small article in the right hand or tying a string around the right arm or leg.
- b. Begin hop backwards across board, right foot hop only, right hand over head.
  - c. Jump to the center of the board, both feet together, jump quarter turns with child tapping his right leg with right hand and saying "right" as he jumps right in quarter turns.
  - d. Repeat "c" starting backwards.
  - e. Right knee touch is carried out in the center of the board. Child raises his right knee and touches it with his right hand as he jumps in the center of the board on the count of one. On the count of two child bends forward at the waist, extending his right leg behind him and right arm forward. Repeat from starting position. Say "right" when touching the right knee.
  - f. Repeat "a", "b", "c", "d", or "e" with eyes closed.
6. a. Jump small jumps to the center of the board, both feet together, left arm extended. Jump quarter turns using "left", and the name of the target to reinforce directional understanding.
- b. Repeat "a" starting backwards, still emphasizing left.
  - c. Pendulum swing: Jump, both feet together, forward to the center of the board. Hop on right foot, while swinging left arm and leg forward and backward and then jump, both feet together, to the end of the board.



- d. Hop, left foot, forward and backward, number of hops determined by the leader's direction. Again using numbers on cards or show of fingers to show number of hops while using words "forward" and "backward" or hand signals reinforces visual with auditory content.
  - e. Repeat "a", "b", "c", or "d" with eyes closed.
- 7.
- a. Hop across board, hopping on left foot only, left hand over head.
  - b. Begin hop backwards across the board, left foot hop only, left hand over head.
  - c. Jump to the center of the board, both feet together. Jump quarter turns with the child tapping his left leg with left hand and saying "left" as he jumps to the left in quarter turns.
  - d. Repeat "c" starting backwards across the board.
  - e. Left knee touch is carried out in the center of the board. Child raises his left knee and touches it with his left hand as he jumps in the center of the board on the count of one. On the count of two the child bends forward at the waist, extending his left leg behind him and left arm forward. Repeat the activity from the starting position. Say "left" when touching the left knee
- 8.
- a. Right and left knee touch is carried out as the leader alternates which leg is to be touched. The leader varies the number of times hops are carried out as three times on the right foot, two times on

the left foot. Right knee touch directions are in 5 "e", page 30. Left knee touch is found in 7 "e" page 31.

- b. Using a review of the jumpboard activities presented thus far, the leader gives directions to children. Watch for smoothness in reverse patterns or in a change of activity.
9.
    - a. Jump to the center of the board, both feet together. Jump quarter turn left; three jumps sideways left; three jumps sideways right; quarter turn right and jump to the end of the board. Use variations of the number of jumps.
    - b. Hop to the center of the board on the right foot; hold up the left arm. Change to the left foot when child reaches the center; hold up the right arm and continue hopping to reach the end of the board.
    - c. Hop to the center of the board on the left foot; right arm held up causing a cross lateral pattern. At the center of the board change to the right foot; left arm held up and continue hopping to reach the end of the board.
    - d. Do "a", "b", and "c" starting backwards or with eyes closed.
    - e. Jump as high as possible in center of board for ten jumps.
    - f. Jump as softly as a bunny jumping in the snow across the board.

- c. Hop across the board on the right foot with the left hand up. Hop across the board on the left foot with the right hand up. Vary this activity by having the child stop in the center to hop forward and backward.
  - d. Repeat "a", "b", and "c" starting backwards or with eyes closed.
12. In place of jump board activities, jumping rope may be substituted or included. Each child in the group should have his own individual rope whenever possible. Group rope activities and games could also be utilized. Music and rhythms work well with jump rope routines.

## Jump Board

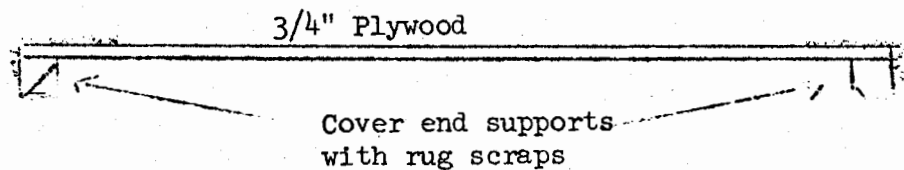
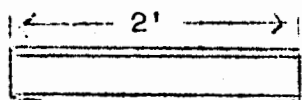
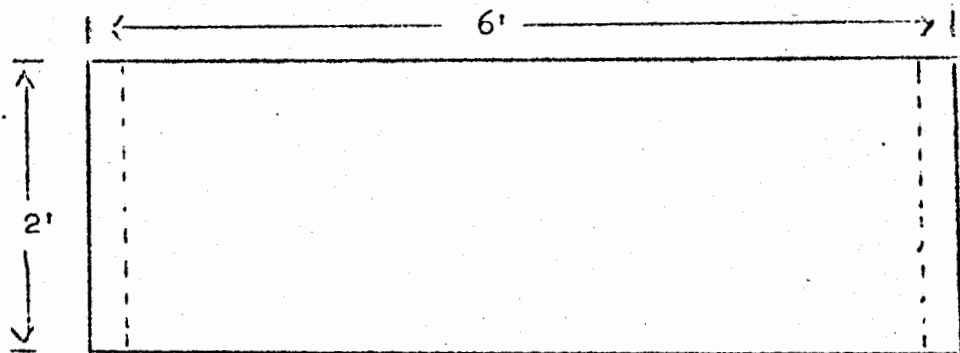
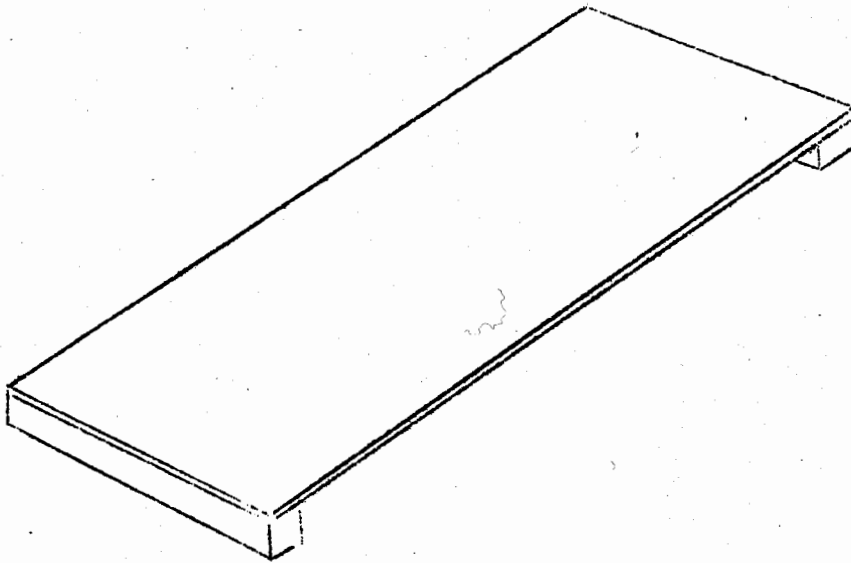
Materials Needed

1. 3/4" plywood - 2' x 6'
2. 4 x 6 - 24" long - bevel inside edges
3. Rug scraps
4. Glue
- \* 5. Cement nails or screws
6. oil stain or paint

## BALANCE BEAM

The purposes of the balance beam are "to have children explore and develop the interrelationships of the sides of their bodies and the combinations of involved movements in balance; to have children visually direct their movements for better balance and coordination." (15:33) If there is a mirror in the room, the child might further observe his own reactions and his body relationships in an awareness of balance and existence in the space provided him.

Sequences in this area were planned to challenge the more proficient child and to reinforce the child having balance difficulty. Removal of shoes is necessary for all of the balance beam activities.

Balance beam activities should begin on the four inch side. When the child is feeling secure and is demonstrating adequate balancing skills, give him experience in using the two inch side. As abilities develop, the leader may choose to introduce a new activity on the four inch side for two days and then change to the two inch width, providing more variety and challenge.

The use of eye targets should be encouraged as soon as the child is able to focus on them. (Eye targets are discussed in relation to jumpboard activities on page 26). First steps may include the child looking at his feet, then sighting the end of the beam, then to eye or hand level of the leader and finally to the wall target. This will progress according to the degree of difficulty and security of the individual.

Activities for the beam are presented in the same sequence as in the BEEP, Basic Educational Experiences Program, (6) and each set was intended for one week's time in that program. Allow enough time for the child to progress at his own speed in Phase II since the intent is to fit each child's program, not that of a group. Directions for beam construction are found on page 84.

Whenever possible boards should be faced at various positions within the room such as to the east one day and the west another. Boards may be placed to form the shape of a square or triangle when those shapes are the unit experience. The child should also begin activities at opposite ends of the boards.

1. a. Walk forward across the beam: Child should walk straight with good posture, arms relaxed, feet straight on the beam walking heel to toe stepping position.
  - b. Walk backward across the beam: Head up, feet with toes, feet straight on the beam toe to heel stepping position.
  - c. Alternate forward and backward walk: Leader designates starting position. At the change command or hand signal the child stops, turns, and continues walking the beam in the opposite direction.
- 
2. a. Pony trot: Walk forward across beam bringing right knee up in tuck position, hold position maintaining balance, continue by bringing left knee up in tuck position.

- b. Pony trot: Walk backward across the beam using tuck position and pausing for an instant at each tuck.
    - c. Turns: Locate center of beam, walk to center, turn on balls of feet and walk back to beginning point. Be sure child finds eye target after each turn.
    - d. Run forward across beam in small steps.
  3. a. Toe Balance: Walk forward to center of beam, raise up on toes (arms extended to side, legs straight, head up), hold balance. Leader may count for balance time or use hand signal -- then continue walking to end of beam.
  - b. Toe Balance: Walk backward to center of beam and balance on toes. Eyes on target.
  - c. Squat Balance: Walk to center, pick up object from the floor as a ball by squatting down to reach it. Try to keep back straight, bend knees. After object has been successfully picked up, continue walking to end of beam.
  - d. Squat Balance: Walk backward, pick up an object as described in "c" above. Leader should give the experience placing article on either side of the beam at the center point.
4. a. Ball Toss: Use fleece balls, if available, or soft bean bags. While child walks across beam, leader or partner throws ball directly at child. Child must try and catch the ball, maintain his balance

- and throw the ball back continuing to walk to end of beam. Eyes should be on the ball.
- b. Repeat Ball Toss: Using the procedure in "a" above, walk backwards.
  - c. Slide Right: Child faces side of beam and extends right arm out at side while holding a fleece ball, building block, eraser or some object in the right hand as reinforcement of right. Step right, slide the left foot up to the right. Repeat across the beam. Child says "right" as the right foot slides.
  - d. Repeat Slide: Start at the opposite end of the beam and slide right to the other end. Child must determine how he should face so that the right foot is leading.
5. Right: At this point, if the right pant leg of the boy is rolled up or the wrist of the girl marked with yarn, it would serve as a reminder or right.
- a. Right Side Extensions: Walk to center of board. While standing on left leg, extend right arm forward and the right leg backward, maintaining balance. Continue walking to end of board.
  - b. Repeat Right Side Extensions: Start walking the beam in backward position. Repeat 5 "a" on preceding page. Leader or child might count length of center balance time.
  - c. Right Turn: Walk to center of beam, extend right arm out at side. Turn right, saying "right", and



continue walking back to starting point. Repeat activity starting at opposite end of beam. Complete half turn is made.

- d. Quarter Turn Right - Slide Right: Walk to center of beam, extend right arm out at side. Turn right in a quarter turn and continue walking with a right slide, step left as outlined in 4 "c" on the preceding page.
6. a. Slide Left: Child faces side of beam, extends left arm out at side while holding fleece ball or other object in the left hand as reinforcement. Step left, slide right foot up to the left. Child says "left" as he steps.
  - b. Repeat Slide Left: Start at opposite end of the beam and repeat 6 "a".
  - c. Left Side Extension: Walk to center of beam. While standing on right leg, extend left arm forward and the left leg backward, maintaining balance. Then continue to the end of beam.
  - d. Repeat Left Side Extension: Start walking the beam in backward position. Repeat 6 "c". Leader or child may count length of balance time.
7. Left: At this point, if the left pant leg of the boy is rolled up or the ankle of the girl is tied with yarn, it would serve as a reminder of left.

- a. Left Turn: Walk to center of beam, extend left arm out at side. Turn left "saying "left", and continue walking back to end of beam. Complete half turn is made. Repeat starting at the opposite end of the beam.
  - b. Quarter Turn Left - Slide Left: Walk to center of beam, extend left arm out at side. Turn left one quarter turn. Continue walking sideways, slide left, step right to end of beam. Refer to 6 "a" above for directions.
  - c. Repeat quarter turn left: Repeat "b" starting backwards across beam.
  - d. Ball Toss: See 4 "a" for directions, page 39. May vary the activity by having child walk sideways to the left while catching the ball.
8. a. Squat Balance: Child walks to center of beam and picks up object which has been placed by leader on either right or left side of beam. Child should identify which side the object is on. Encourage child to bend knees and keep back fairly straight while picking up object.
- b. Dip Step Right: Child walks forward slowly, swings the right foot toward the floor, left knee slightly flexed. Continue forward and repeats swing, saying "right" when he swings leg.
  - c. Dip Step Left: Repeat "b" above swinging the left leg.

- d. Review: Use slide step right and slide step left in previous lessons starting at opposite end of beam. Leader may choose from any of these activities, but should give experience using both left and right sides.
9. a. Cross over step: Child faces side of beam, steps right, crosses left foot over right and repeats this pattern across beam. Repeat this activity at the opposite end of the beam.
- b. Right arm - left leg extension: Walk to center of beam. While balancing on right leg, extend right arm forward, left leg backward. Head should be up. Then continue walking to end of beam. Repeat activity starting backwards.
- c. Two Step: Take two steps on the beam, step both feet off the beam on the right side. Take two steps on the floor; step back on the beam for two steps. Step off the beam on the left side; take two steps on the floor; step back on the beam. Begin this activity over starting with the right side step off again. This must be a slow moving activity. Child should vocalize "right" or "left" when stepping to the floor.
10. a. Cross Over Step: Child faces side of beam. Step left, cross right and continue to the end of the beam. Repeat starting at the opposite end of the beam.

- b. Left Arm - Right Leg Extension: Walk to center of beam while maintaining balance on left leg. Extend left arm forward, right leg backward. Head should be up and eyes should be on target.
11. a. Slide - Step - Arm Raise: As child slide steps to the right he extends his left arm out at the side. He drops arm to side position when feet come together. Slide - step right - right arm out - return foot and arm to starting position. Progress in this manner to end of beam.
- b. Repeat Slide-Step-Arm Raise: Repeat "a" above stepping left and raising right arm. Give child experience in starting both "a" and "b" at opposite ends of the board calling for the right or left foot to lead off. Child must then decide how to approach the beam.
- c. Bean Bag Balance: The child walks across the beam while balancing a bean bag on a yardstick. The leader may vary the position of the yardstick and the type of foot movement across the beam as:
- ..Both hands holding yardstick out in front while balancing the bean bag on the end of the stick.
  - ..Right or left hand holding yardstick out in front while balancing bean bag on the end.
  - ..Hold the yardstick in either hand balancing a bean bag on the end of it while slide stepping sideways across the board.

..Hold yardstick at each end with both hands across the front of the body while varying type of movement across the board as small running steps, pony trot or crossover step.

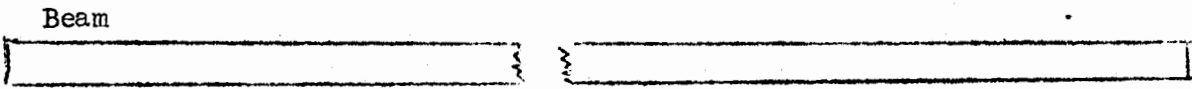
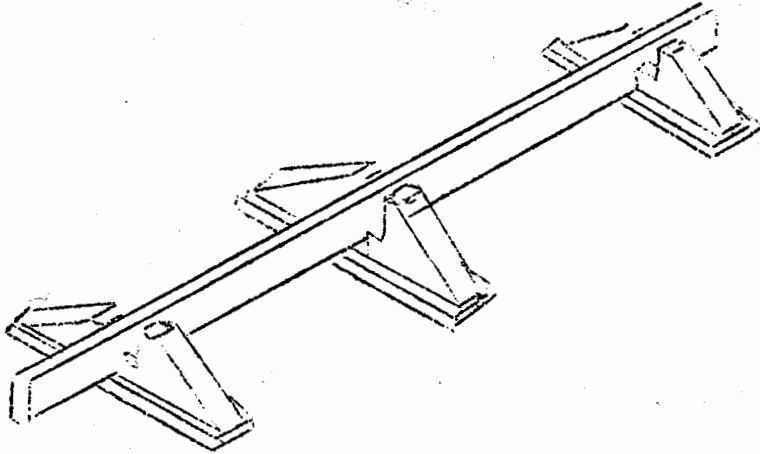

standard 2 x 4  
10" long

beam support  
(3 needed)

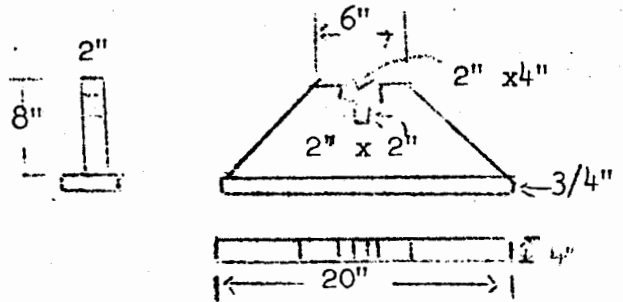

Materials Needed

1. 2 x 4 10' long
2. 2 x 8 5' long (3 pieces 20" long needed)
3. 3/4 plywood 4" x 60" (3 pieces 20" long needed)
4. glue
5. cement nails or screws
6. oil stain or paint

## EYE - HAND COORDINATION

The smooth accomplishment of our learning depends upon adequate eye-motor coordination in control and accuracy of eye movements. Visual-tactual opportunities give a basis to learn that hands work together as a pair or function separately as the task requires. Interpretations and manipulations with the following experiences encourage a child to perform tasks independently, depending upon his own resources of self-discipline to discover the implications of materials provided for him.

If a child is unable to distinguish between shapes, it is important to know if his difficulty is in the term itself or recognizing visual differends. Additional help should be provided so he feels secure in his effort and confident in his challenge.

An attempt should be made to review that particular shape or shapes by exploring all possible avenues of understanding. The child might form the shape from coiled clay or cut it from rolled clay and have it fired and glazed for permanency. He might "squirt" the shape or letter onto a graham cracker with a frosting mix for a delicious reminder. He might use a special marking pencil or crayon and toy with the symbol over and over in a pleasing design for repetition. Every possible opportunity should be given him to further relate any activities of the previous experience units. He should be offered elements of surprise to create a feeling of confidence in his ability to succeed.

Manipulative equipment lets a child see relationships of patterns allowing him decisions and judgments both of which are

important in academic tasks. It prepares him for future planning and organization of assignments.

1. Stepping Stones: Cut out 20 "stones" about six inches in area using the appropriate shape for the unit in progress or to be introduced. Ten stones should be of one color as red for the right foot. Ten should be of another color as lavender for the left foot. Cutting these stones should be an activity of the child before placing them.
2. Shape Book: This could be a collection of pictures and drawings of the actual form in varied sizes, positions and colors and its inclusion in every day living as in buildings, home, school, nature, industry, communication, travel and space.
3. Form manipulation with puzzles: These help the child become more familiar with the structure of shapes and interlocking patterns. Use sources from the building and the perceptual consultant.
4. Pegboards: Leader provides patterns in pegs for matching which could include one shape, two separate shapes and two or more interlocking shapes. Encourage experimentation by the child in forming a design for another child to duplicate.

Other experiences might include:

- a. Walk the same patterns out on the floor with the pegs as a "map" or "trail".



- b. Draw the same pattern on paper or on a chalkboard.
5. Bean Bag Toss Games: Toss targets can be cut from colored paper in the desired shape or colored for staying within lines. Shapes can be set on the floor for the tossing. Shapes can also be cut into the side of a cardboard box. Vary the distances in throwing to offer challenge and assure success.
6. Concentration or Fish: (This activity is also excellent for visual memory.) Matching required concentration and attention. Turned into a game constructed by the child himself, it assures complete involvement.
- a. From tagboard have the child cut circles of the intended shape about two inches in area. Let him arrange these in pairs. Give him the opportunity to draw identical marks on each pair. Ten to fifteen pairs is adequate in the beginning. By using letters or words giving the child difficulty in spelling, reading or writing, attention is reinforced to an added goal.
- b. Work in partners or small groups. Turn the shapes over to the blank side and spread out on a table so they are not touching. A child then turns over two shapes and puts them back on the table, marked side up, in the same place so others in the game might see them. If they do not match, the child turns each over, face side down, keeping them in the same

place so all players can concentrate on the positions. The game continues with the next player turning over two cards and following the same procedure. The object of the game is to see who can find the most matched pairs.

The intended shapes may be cut from paint chart samples and the players then try to match colors. Older children might match words that start with the same letter or words that rhyme.

7. Sewing Cards: These can be made by using the basting stitch on a sewing machine upon an index card or by poking holes through the card with a needle. A child may sew the outlined shape with needle and thread. Size of the intended shape can be varied on a card and the designs can be overlapped.
8. Sorting: Quantitative relationships between numbers and objects as well as between types of objects can be of value. Label muffin tins or small boxes with content name. The number of each can also be included, if this is a desired concept as: six marbles, four rocks, ten tacks, twelve rubber bands. Older children may use combinations as; five and four paperclips or ten minus two pencils.
9. Stuffed Shapes: Cut out of paper two identical shapes and staple 3 of the sides together. Stuff with crumpled paper and continue to staple until the shape is closed.

These shapes can also be holiday symbols as: stars, Christmas trees, shamrocks, hearts, pumpkins or animals.

10. Targets: Providing targets for the jumpboard, balance beam or bean bag toss and other equipment to be used in games makes a meaningful objective for children's activities in this station.
  
11. Colorful Handprints: Children trace their own handprints and cut them out of colored paper. It is helpful to have each child choose a color of his own for his handprints. Mount these with tape in various positions on a board or table top so children can match left and right hand positions. Arrange some of the prints so they require crossing over one another for matching of pairs.
  
12. Shape Cages: Use butcher paper and help the child trace around himself as he sits within the borders of the intended shape. This should be about 36 inches in area. A pattern will need to be provided for a guide. The hula hoop provides an adequate circle.
  - a. Have the child perform some of his pencil-paper tasks while he is confined within this cage. He might build with blocks or work on a sewing card of the same shape while he is confined to it.
  - b. On another day have the child work around the outside boundary of the shape drawing around the outside edge again. He should use a heavy crayon or felt tip pen in a continuous movement and crawl along with the tool. He might then cut out the shape.

- c. On the following days the child might perform the beginning group activity, stunts or animal walks around the outside or within the boundaries of the shape itself.
  - d. Other possible activities could be:
    - ..Run a small car around the edge.
    - ..Put the car in the middle of the shape.
    - ..Stand in the middle of the shape.
    - ..Walk around the outside edge of the shape.
    - ..Jump into the middle of the shape.
    - ..Build a fence of blocks around the shape.
13. Building Blocks: Constructing, manipulating and match-form or object position are valuable. Leader might build a pattern for the child to reproduce.
14. Pouring: The concept of quantity in pouring the same amount of water into various sized containers requires constant visual response in judging the flow and content.
15. Balero Bottle: A plastic bleach bottle with a ball attached with a string provides practice in catching a ball in a container. Children might work in partners so that one child can also toss a fleece ball or bean bag into the same container.
- Directions for the ball are:
- a. Plastic bleach bottle, 1 gallon or  $\frac{1}{2}$  gallon size.
  - b. A two or two and a half inch brightly colored rubber ball.

- c. Heavy twine or cord cut to two and one half feet.
- d. Cut bottom out of the bottle.
- e. Insert string through ball and secure with sturdy knot.
- f. Attach cord through bottle and fasten on opposite side of handle. (See diagram below.)

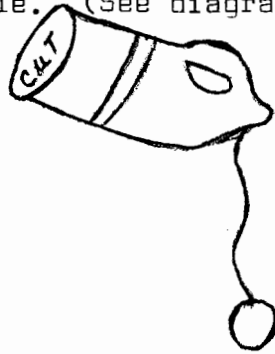

- 16. Braiding: Three old nylon hose knotted at the toe end and secured to a chair or table leg make excellent braiding material. (This makes a cat or lion tail or can be used for a wig for Halloween or a play costume.)
- 17. Tracing: Use onion skin or tracing paper in the reproduction of a given shape to be then cut out, colored in or arranged on a specific sheet.
- 18. Paper Sculpture and Folding: Books and directions for various designs are available from libraries. This is an excellent source of providing real reason for listening to and following directions.
- 19. Folding the Shape and Use of Parts: Fold the desired shape into parts as the circle into four parts. Make pictures in each part starting with a letter that the child may need extra work on such as m or d. The parts

could be cut apart and pieced together again as a puzzle. The shape could be folded into two parts and activities might be directed to the top and bottom of the shape or the left and right side.

20. Commercial Games and Materials: Many of these are available in the perceptual development area of learning. Check with each building and with the perceptual consultant to see what is supplied and how they may be utilized.

## PURPOSES AND GUIDELINES

PENCIL - PAPER TASKS AND CHALKBOARD ACTIVITIES

Being able to recognize likenesses and differences between objects or symbols quickly and accurately is essential to word recognition and to success in total school tasks.

Working with templates, Frostig sheets and related worksheets is designed to provide a realization of size, variance, over-lapping and joining of shapes and placement of symbols and figures.

The sampling of work suggested in the Experience Units utilizing Frostig sheets is taken out of content for the purpose of giving a child participation in all five areas of the Frostig developmental program. It is most important that the child feel a sense of satisfying achievement. Those having difficulty in any area should be provided with the beginning sheets for that specific ability and follow them in sequential outline as provided in the Frostig Manual (14).

A continuation of this work in the child's classroom may be helpful since an entire battery of Frostig sheets is detailed and too lengthy for adequate coverage during Phase II.

"In all of learning and perception the first awareness is of the total situation, and as essential elements come to the fore, the behavior is made aware of his need for each part. All behavior is a type of problem solving related to the individual's ability to perceive new or different aspects of a complex situation." (11:117).

In relation to this theory, whenever possible precede all pencil-paper tasks with actual involvement with the child and the situation. Positioning himself in relation to the diagrams presented or the task at hand assures his personal relationship relevant to the assignment.

For example in the Frostig sheet for figure-ground 14 involving lines and stairs, the child should first walk up and down stairs if they are found in the building. With help he may also do this with his eyes closed. He then could build stairs with blocks and "walk" up them with his fingers. This sheet then becomes meaningful and purposeful when a pencil is to outline stairs.

1. Worksheet Procedures:

- a. Begin by drawing the intended shape for the week, as the circle or square, in a corner or at the top or bottom of a Frostig or other worksheet. Direct the child to put his name by this shape as, "Put your name by the circle at the top left hand corner of the page."
- b. Have the child locate this same area on his next sheet and ask him to put his name in the same place without the shape as a guide.
- c. Have the child tell where he is going to put his name as, "I am going to put my name on the upper right hand corner of the paper", and let him carry out his own direction.



- d. A variation might be to put three circles, or intended shapes, on the paper and have him put his name in a certain shape as, "Put your name in the circle farthest to the right".
- e. Make a page filled with rows of the intended shape

arranged in this manner:



..Put an X in the circle in the lower right hand corner.

..Outline the circle next to the last circle in the second row.

..Color the third circle in row three green.

..Have the child identify placement of a circle and tell how he is going to identify this circle.

2. Templates: Templates are forms cut from heavy tag-board or cardboard. They may be used in shape recognition, reinforcement and smooth construction practice on both the chalkboard and paper.

"All Templates should be used to guide the child's preferred hand at first. As skill is acquired, the nonpreferred hand should also hold the chalk. This switching of hands emphasizes the kinesthetic (muscle sense) and proprioceptive (movement). Skill and fluidity of movements are desired for both hands, but no attempt should be made to alter a child's hand preference." (15:5)

In developing basic form comprehension, a child must be able to perceive the relationships of size, shape, differences,

likenesses and contour that are important to future interpretations of symbols. Form recognition reinforced by motor-response activities in coordinated eye-hand movements is in direct relationship to classroom learning.

Templates should be turned in varied positions, overlapped in forms as circles over circles or squares over circles until the final Experience Unit Six is introduced. Then all the forms can be overlapped upon one another. Use of one color of crayon or felt pen for each complete closure of form helps the child realize its individual position within an overlap design. By tracing these over and over with his finger, following a designated color line, he further realizes one shape and its relationship on the page and total design.

3. Templates and Ocular Pursuit: A child needing practice in smooth eye movements can work with these templates in the following manner:
  - a. Feel the outline of the shape in its continuous outline with a finger. Watch the finger movement while the outline is being traced. Template is set on a table during this time.
  - b. Take the finger away and follow the shape's continuous outline with only eye movements. Reverse movement.
  - c. Feel the outline of the shape in its continuous outline watching finger movement while the template is held up in front of the child. Reverse the movement.

d. Take the finger away and follow the object's continuous shape with eye movements only. Be certain template is in a position so as to look directly into the glare of a window or light.

4. Chalkboard: "Chalkboard activities provide the child an opportunity to learn that hands work together as a pair, in support of each other, and in various degrees of unity. (14:43). They also provide an excellent means for developing better visual motor skills so necessary in classroom skills. The leader would be alert for jerky, rough, or tight movement patterns. Encourage smooth and free movements.

The child should stand comfortably erect, 12 to 14 inches from the chalkboard. Both feet should be on the floor, slightly separated. His posture should be one of relaxed erectness, so arms and hands can move freely. He must not stand in a crooked or one sided position.

It will be necessary to demonstrate the correct procedure for holding the chalk. It is not held like a pencil but rather in the bend of fingers with the thumb supporting the chalk. Large chalk broken in half and not held too tightly produces the most effective movement.

Specific instruction and teaching suggestions for a complete sequential series of chalkboard activities can be found in BEEP, Basic Educational Experiences Program. (6:7-9) Because of the time element in Phase II, a child would not be able to follow the

entire program as structured in that program. It may be beneficial, however, to provide various chalkboard activities as:

- a. Tracing Forms: Child traces around the intended experience unit form using templates as a guide. The preferred hand is actively working towards accurate visual motor control and smooth continuous motion. Only when satisfactory circular motion can be maintained should the leader signal change in direction.

A midline drawn vertically on the board in front of the child is a helpful guideline in maintaining his position at the chalkboard. With this as a guideline, the child might trace shapes in various placements to the midline as: to the right or left, on the midline itself, or high or low on a given side. The child should not change his body position but be encouraged to reach when crossing the midline.

The retracings might be termed "trip" and their number counted by the leader or child.

- b. Chase the Dot: Children may work in partners or with the leader. One child (or leader) places a dot on the chalkboard; the other places his chalk on the dot. He continues to chase or draw straight lines to hit the other dots being placed on the board. The child should not take his chalk from the board during the chase and the leader must wait until the child has drawn his line before placing the next dot.

The dots would be placed at random, however, within easy reach of the child. Vary the position of the dots so the child experiences drawing lines up, down, and across his midline. Encourage the child to really look and hit the dot.

### AUDITORY AWARENESS AND DISCRIMINATION:

It is felt that many of the problems of auditory span, temporal order in a series of information and the like may be related to weaknesses in ability to establish and/or maintain rhythm patterns. "Research shows us that no words are read without being silently sounded. Better readers are better listeners." (23:9)

These activities help a child establish a reason and purpose for listening for and talking about what he hears by offering a variety of experiences in a supportive atmosphere. They provide a limitless scope to express his feelings and a chance to become actively involved in his own learning. As spontaneous verbal responses that clarify and extend information are encouraged, a child's sensory awareness and communication sensitivity are stimulated.

Listening to a child and enjoying and approving of what he is saying stimulates him to try new words and descriptions. The activity leader is in a prime position to give tremendous opportunities for self-expression as well as for auditory discrimination and awareness.

"Listening instruction should be based on the total listening process and provide for training in: auditory awareness, auditory discrimination, association of sound in sequence with meaning and development of thoughtful, discriminatory responses." (20:1)

1. Ball Bouncing Patterns: At first the leader begins by bouncing a ball twice in front of himself, then says his name and tosses the ball up in front of himself catching it each time. The ball is tossed to the child

who then tries to repeat the bounce-toss pattern and to put his own name in between. Pattern may be varied in the development of a new sequence for repetition.

Other routines might include bouncing the ball behind, to either side or in front for a certain number of times. Bounce, catch, foot tap sequences may later be developed. The incentive to listen becomes greater when the child also has an opportunity to create his own patterns that others must reproduce.

Development of a too complicated pattern is soon discouraged by setting a procedure that the "leader" presenting the pattern must also repeat it once for others to study before passing on the ball. This helps build confidence in expressing ideas and reason for remembering given sequences and actions.

2. Hand Clapping Patterns: Present a patterns of claps combined with placement of hands in relation to the body as over the head, behind the back or by the feet. Vary patterns not only by the number of claps and hand positions but also by loudness, softness and speed.

Have the child turn his back to the leader. Leader gives a clap code or pattern. The child "sends" it back by repeating what he has heard and remembered.

Leader established a pattern of hand claps for a certain number of times between names in a category or sequence. For example: Clap, clap, Monday, clap, clap, Tuesday, clap clap and so on with the days of the week. This could apply to months of the year, numbers, spelling of a word or listing of farm animals.

3. High and Low Tone Response: Listen to high, low and in-between notes on tone blocks, the piano or bells. Child responds by reaching high or low according to the note. Have him repeat the activity with his eyes closed. When stairs are near and he can respond by climbing or descending stairs corresponding with note positions, total body movement is in response to sound.
4. Listening for Sounds: Listen, with eyes closed, to all the sounds in the room as a clock, ball bouncing, hand clapping or paper tearing. Identify the sound according to what or who made it and from which part of the room it came.
5. Remembering: Directions are given to a child and are to be responded to in the same sequence as given. For example: "Find a circle, bring it to me, sit down on the floor and cover your eyes." Increase the number of directions as the child is able to successfully remember them.
6. Verbal Drum Beats: Repeat drum beats verbally after they are first tapped out on a drum. Show emphasis in voice where it has been put in the drum beat as: ta, ta, ta-ta-ta.
7. Spatial Dot Patterns: Have dot rhythms on paper or plan them with the child as they are tapped. Tap out a rhythm and match it to the dot pattern. For example:



(1) .. ... (2) ..... (3) .. .. (4) . .. .

The blank spaces indicate pauses.

Have the child listen with his eyes closed and then pick out the dot pattern that was tapped.

8. Paper Plate Rattlers: Put a number of the same objects in a paper plate such as seven marbles. Glue another paper plate on top of this plate. Label the surface of one of the plates with the name of its contents.

Continue "stuffing" plates with the same number of other objects as paper clips in one, marbles in another and seven pieces of paper in another. Label each with the name of its contents.

Turn the plates over so that the labels cannot be seen. The leader picks each one up, one at a time and shakes it. The child tries to determine the contents by sound. If he needs additional help, let him shake it to feel the weight.

9. What Made the Sound: Have the child turn his back to the leader or another child. Make sounds as scissors cutting, paper tearing, a bell ringing, a bottle of water shaking, pencil tapping, hands clapping or leaf crunching. Have him try to identify the sound.

Plan a series of three or more sounds and have him identify what he heard in the order he heard it.

Have him tell how many times he heard the pencil tapping or the scissors cutting as this sound is inserted several times within a grouping of other sounds.

Have him close his eyes and listen to a sound. Then open his eyes and repeat the same sound by using the same object. Special attention should be called to the loudness, softness, length of time or speed with which the sound was presented.

10. Listening for Directions: Give the child a blank piece of paper cut in the intended shape concentration for the particular session. A special crayon or felt tip pen for marking gives additional incentive.

Begin directions as: (1) put an X in the middle of the page, (2) put your last name below the X, (3) put a big circle (or the intended shape) at the top of the page, (4) fold the paper in half, and (5) make a picture of something shaped like a circle (or intended shape) in the bottom half of the shape.

11. Spotting (Regular and Irregular Sequence): On a large chart make the intended shape in columns. Have the child focus on one shape according to direction as: "Look at the black circle with tiny white circle in the center." Wait for the child to focus on this circle and count to a certain number, as three, while he maintains focus at this point. He is to hold his head still and move only his eyes.

Have him move to the next shape and maintain focus for a counted or tapped number. Change the speed of focus and vary the sequence of order.

A child might make his own spotting chart by drawing, cutting, pasting, coloring or tracing for complete involvement in form constancy.

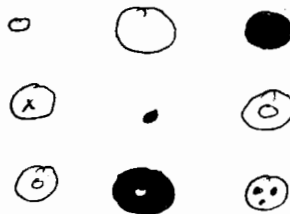

12. Use Learning Time with Language Experience for Young Children: Additional listening activities are listed in this book. (28)

## VISUAL MEMORY:

By developing a greater awareness in likenesses and differences in color, size and shape and being able to perceive these visually, recognize them tactually and describe them verbally, a child gains meaningful information for future academic use. Many of the Frostig materials in the pencil-paper tasks deal with this process. Other procedures for a child needing concentrated training in this area might include:

1. Objects and Pictures: Matching real objects to pictures for form identification regardless of size, color, background, angle of viewing, position or texture. This could include having the child participate by bringing an object such as a toy truck along with a picture of a truck. These might be added to a collection of objects and pictures for future matching activities.

Put the real objects in a sack or box. Have the child reach in and identify them by touch. Then he should take the object out of the container to be matched with the picture.

With this as his background information, he should be presented with a sheet or page in a book showing a truck or other objects in the collection. Ask him to point out the given object and tell something about it.

The final step of this process comes when the child has a paper on the desk and is asked to identify the truck or other object by circling it or drawing a line under it or some other means according to the leader's direction.

2. Object Classification: Provide a variety of objects including sharp, soft, hard, smooth and so forth.

Have a sack marked for each classification and let the child determine where each object belongs.

Have the child feel the objects in each sack, without looking at them. As he decides what it is, he takes the object out. He continues this until the sack is empty.

Put objects into a sack without the child's seeing them. By touching them have him decide into which classification sack it belongs and place it there.

3. Pattern Reproduction: Show a pattern built with blocks or beads. Let the child study it carefully and then let him reproduce the identical pattern.

Have the child build the same pattern on a piece of paper using cut out shapes in place of the blocks or beads. He could trace around the needed shapes that would be provided by the leader and cut them out himself before arranging them.

Have a child build his own pattern and present it to another child to reproduce. This provides an opportunity and purpose to think, plan, execute, evaluate and share his ideas.

4. What's on Stage: Take the top and bottom out of a cardboard box. Set it on one side. String a curtain across one end for a "stage". Place objects or shapes behind the curtain for the child to reach through and identify.

Encourage language usage. For a child who finds verbal expression difficult, put a finger or hand puppet on the hand not being used for object feeling. Let the puppet "sit" on top of the box and tell what is being felt.

5. Furniture Arrangement: Pretend "box house" can serve as a room for the arrangement of doll house furniture. Arrange it and have the child study the plan and then turn around. Change one piece of furniture to a different position and see if the child can return it to the original arrangement. Children could take turns in a small group with this activity. Let them arrange and change the positions of furniture for other group members. Number of articles changed at a time depends upon the success of the children in being able to rearrange the furniture.
  
6. Who Moved? Have several children sit in a certain order. Let one child leave the group and turn his back to them. Have the remaining children scramble positions. See if the child can place everyone back into original order.

Have one child hide his eyes. One child leaves the group and goes out of the room. The child hiding his eyes tries to determine who left and to tell something about what they were wearing.

7. What's in Your Hand? Place an object in a child's hands that are held behind him. Write down the words that he uses to describe the object as he tries to guess what it is. Encourage his exploration of descriptive words. Guide his language experimentation with new terms or phrases as he carefully inspects the object, first tactually in his hands behind him and then visually as the object is in front of him.
8. Perceptamatic or Tachistoscope: (This is available by loan from the perceptual consultant. This machine provides stimuli for visual memory response and eye contact development.) (23)
9. What's on Your Back? Write shapes, letters or numbers on the back of a child. Have him repeat the same symbol on your back and say what it is as identification.
10. Sequential Series: Present numbers, shapes, letters or words in a sequential series. Take a letter or number out and leave a blank space for the child to supply the missing item. A child's phone number, alphabetical or numerical order, months of the year, days of the week or word lists related to the child's class work may be utilized.
11. Slides or Film Strips in Story Development: Use slides or film strips in a darkened area of the room. Encourage vocabulary expression, sequence in development of

details, comparisons and interpretations. Security in the darkness matched with interest in the film offers the child having difficulty in verbal communication more freedom for expression.



### STEPPING STONES:

By stimulating a child to move according to a required direction he is reacting to controlled movements and he is developing eye-foot coordination. This develops a child's ability to change control of his legs and trunk under conditions which demand irregular performances and prepare him for future movements within and outside of classroom activities.

Cut twenty "stones", about six inches in area, from construction paper. These should be in the shape of the form for the unit being stressed. Cutting of the "stones" and placing them in position on the floor might be an activity of the children who are to be involved in performing upon them. Their placement, as well as their shape, reinforce the form.

One color, as red, might signify the right foot and one color, as lavender, might signify left.

Cross-over patterns allow for balance and coordination challenge and adjustment. Suggestions for such placements are found under Stepping Stones for each Experience Unit: circle, page 77; square, page 79; rectangle, page 81; triangle, page 83, and the diamond, page 85.

Variance in activity might come by emphasizing one leg with more force than the other, freezing in position at a given signal, and going fast or slow. By stopping at designated intervals, the child "freezes" or "statues" his body in maintained position to a given count of time. Hand signals might be used to show "freezing" and "thawing time" indicating the stopping and starting time of the activity.

By accenting one foot with corresponding arm movements, additional skills are introduced. The right hand might slap the right leg or right shoulder as a step is taken on the right foot.

Only the most capable child will be able to develop a cross-lateral pattern with the right foot and left arm in one action. This should not be introduced until a smooth relationship with one sided movement is established.

The following activities are taken from BEEP, Basic Educational Experiences Program (6), and should be adapted according to each child's needs and the program's emphasis.

1. Child jumps with two feet together from one circle, or shape, to the next. Increase speed. Watch for ease in changing direction.
2. Continue jumping both feet together. Vary jumping from soft to heavy, high to low or fast to slow.
3. Child walks around stones matching correct foot to color and saying "right when he steps right or "left" as he steps left.
  - a. When stepping right, raise right hand.
  - b. When stepping right, clap hands in front.
  - c. When stepping right, thrust right hand forward.
  - d. When stepping right, clap hands behind back and say "right".
4. Repeat the activities in 3 above emphasizing the left foot.

5. After the child is at ease in the unilateral patterns suggested in 3 and 4, the following cross-lateral steps can be introduced.
  - a. Child walks around stones placing correct foot on corresponding color, saying "left" and "right" naming each step as he takes it. Have the child increase speed, but the leader must be alert for any confusion of right and left and correct color match.
  - b. Step left, hop right, step left, hop right.
  - c. Hop left, step right, hop left, step right.
  - d. Play freeze or statues with the child holding a body position and balance as the signal is called until the given signal to continue is directed.
  
6. Child walks around steps starting at the opposite end of the shape with right foot leading, crossing the left. The leader should be alert to see that the child has matched correct color and foot. Child should verbalize which foot is being used. Vary speed and activities as time allows.

FINAL GROUP ACTIVITY:

At the end of the designated daily time there should be a last minute final group activity. It is designed to be a pace setter for smooth return to classrooms in readiness for work. Children are dismissed from their last station to his final group activity.

Once again there is a quiet reinforcement formation of the shape being stressed for the period. This should follow the procedure establish in the beginning group activity as is found on page 20. Personal involvement in the formation of the shape and continuity of the group are realized. Children are then dismissed to classrooms.

### Experience Units

The basic purposes and guidelines for each activity may be applied to each of the following Experience Units:

The Circle

The Square

The Rectangle

The Triangle

The Diamond

All Shapes

## THE CIRCLE:

The formation of the circle involves constant direction and continual rhythm of hand movement to complete the closure. Reversal in this movement offers visual inspection and realization of its continual pattern.

Beginning Group: Review PURPOSES and GUIDELINES on page 20-24. Plan appropriate activities in relation to the number of individuals participating and the intended shape.

Jumpboard: Check the PURPOSES and GUIDELINES, page 26-34 for introduction and jumpboard procedures.

Balance Beam: Check the PURPOSES and GUIDELINES, pages 35-44, for introduction and procedures.

Eye-Hand Coordination: Choose activities from the procedures suggested on pages 45-52. Form a circle with yarn dipped in liquid starch and mount on paper. Have the child keep materials in his box or folder.

Pencil-Paper Tasks: Read over the PURPOSES and GUIDELINES on page 53-54. Correlate the use of the following Frostig sheets: Visual Motor 28, 30, 52, 58, 60, 61, 84; Figure Ground 61, 65, 65a, 65b; Perceptual Constancy 6, 8, 18, 22, 31, 34, 42, 54, 57, 67, 68, 69; Spatial Relations 8, 18, 25, 26, 27, 65, 66; Position in Space 8, 19. Use the Frostig Teacher's Guide, (14), for specific directions.

Auditory: Read through the PURPOSES and GUIDELINES on pages 60-65 and prepare for procedures to be developed during this unit.

Visual Memory: Read over the PURPOSES and GUIDELINES on pages 66-70. Adapt activities in consideration of materials readily available until others can be provided or constructed by the leader with the help of the child involved.

Stepping Stones: Placement of the stones around a circle according to the diagram below:

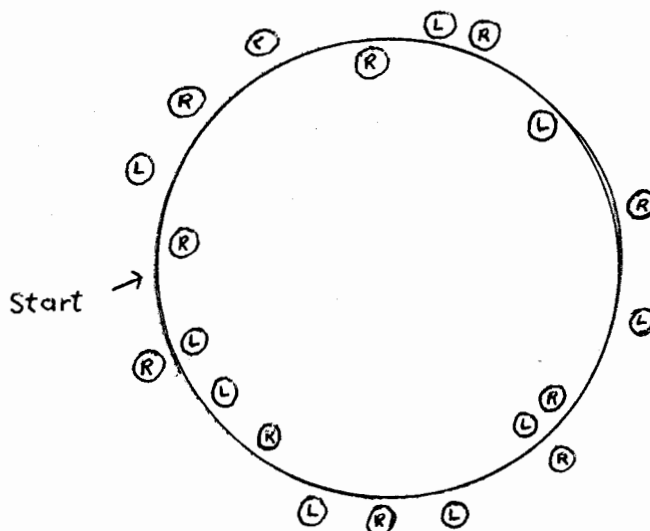

This should cover about a ten foot area.

See PURPOSES and GUIDELINES, pages 71-73.

Final Group Activity: Refer to page 74.

## THE SQUARE:

The square demands stopping the hand movement at a designated point and starting the line sequence in a different direction to achieve the necessary sharp corner. The concept of equality in line formation must be made meaningful.

Beginning Group: Review PURPOSES and GUIDELINES on pages 20-24. Plan appropriate activities in relation to the number of individuals participating and the intended shape.

JUMPBOARD: If four boards are available, arrange them in a square and continue activities in sequence across all four boards, pausing at each corner. Eye targets should be squares.

Balance Beam: If four beams are available, arrange them in a square and continue activities in sequence across all four boards, pausing at each corner.

Eye-Hand Coordination: Choose activities from the procedure suggested on pages 45-52. Adjust activities according to the child's needs and the unit's purpose for maximum effectiveness in manipulative skills. Construct this form with toothpicks and glue onto paper. Have the child keep materials in his box or folder.

Pencil-Paper Tasks: Consult pages 53-59. Correlate Frostig sheets: Visual Motor 78; Perceptual Constancy 1, 16, 17, 23, 29, 33, 43, 44, 50, 56; Position in Space 26, 27, 28, 29, 30, 31, 32,



33, 34, 35, 36; Spatial Relations 1, 31, 32, 67, 68. Use the Frostig Teacher's Guide, (14), for specific directions.

Auditory: Continue the routines established in the previous weeks adding new activities varied to meet the intended purpose of this unit wherever possible.

Visual Memory: Read over the PURPOSES and GUIDELINES on pages 66-70. Adapt activities in consideration of materials readily available until others can be provided or constructed by the leader with the help of the child involved. Include activities with the circle already presented.

Stepping Stones: Placement of "stones" around a square to cover about a 6 foot area. Check directions according to pages 71-73.

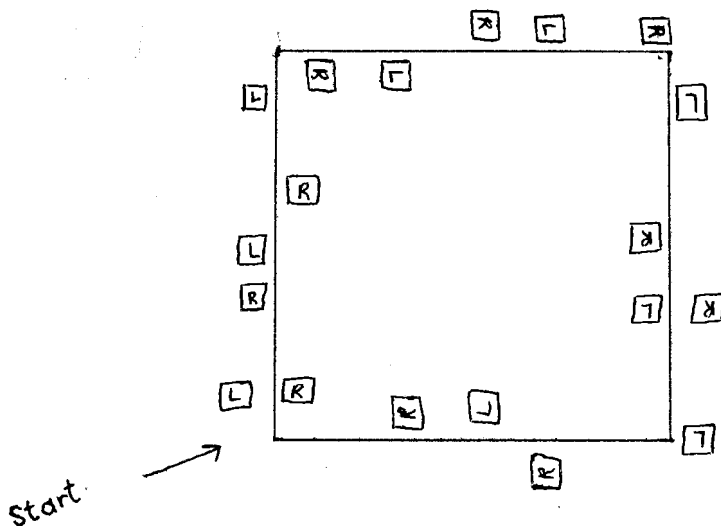

Final Group Activity: Refer to page 74.

### THE RECTANGLE:

The rectangle introduces proportionate relationship of parallel sides to the stopping and starting closure completion of the square.

Beginning Group: Review PURPOSES and GUIDELINES on pages 20-24. Plan appropriate activities in relation to the number of individuals participating and the intended shape.

Jumpboard: Three boards might be arranged with two together representing the longer parallel side of a rectangle and one board by itself representing the shorter side. The concept of a square as a rectangle is not advisable at this time. Continue activities in sequence. Eye targets should be rectangles.

Balance Beam: If three beams are available, two together end to end would represent the longer parallel side of a rectangle and one board by itself would represent the shorter side. Continue activities.

Eye-Hand Coordination: Refer to pages 45-52 and adjust activities according to the child's needs and the unit's purpose for maximum effectiveness in manipulative skills. Have the child keep materials in his box or folder. Construct this form with toothpicks and glue onto paper.

Pencil-Paper Tasks: Consult pages 53-59. Correlate Frostig sheets: Visual Motor 71, 79, 82, 83; Figure Ground 3, 4, 33, 42,

58; Perceptual Constancy 19, 20, 28, 32, 55, 61, 62, 64, 66;  
 Position in Space 12, 13, 14, 20; Spatial Relations 69, 80, 81.  
 Use the Frostig Teacher's Guide, (14), for specific directions.

Auditory: Continue the routines established in the previous weeks adding new activities varied to meet the intended purpose of this unit wherever possible.

Visual Memory: Read over the PURPOSES and GUIDELINES on pages 66-70. Adapt activities in consideration of materials readily available until others can be provided or constructed by the leader with the help of the child involved. Include activities with the circle and square already presented.

Stepping Stones: Placement of "stones" around a rectangle to cover about a 6 foot area. Check directions according to pages 71-73.

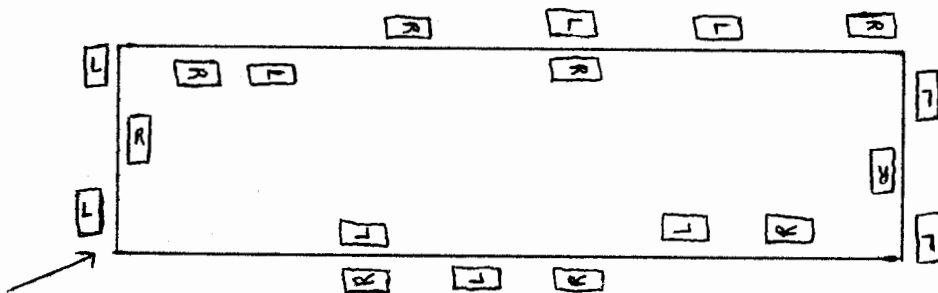

Final Group Activity: Refer to page 74.

### THE TRIANGLE:

The triangle combines diagonal lines with a horizontal base line still including the previous factor of stopping and starting at corners as for the square and rectangle.

Beginning Group: Review PURPOSES and GUIDELINES on pages 20-24. Plan appropriate activities in relation to the number of individuals participating and the intended shape.

Jumpboard: If three boards are available, arrange them in a triangle shape observing the diagonal approach at each corner. Continue activities in sequence around all three boards, pausing at each corner. Eye targets should be triangles.

Balance Beam: If three beams are available, arrange them in a triangle shape observing the diagonal approach at each corner. Continue activities in sequence around all three beams, pausing at each corner.

Eye-Hand Coordination: Construct this form with toothpicks and glue onto paper. Choose activities from the procedures suggested on pages 45-52. Have the child keep materials in his box or folder. Adjust activities according to the child's needs and the unit's purpose for maximum effectiveness in manipulative skills.

Pencil-Paper Tasks: Consult page 53-59. Correlate Frostig sheets: Visual Motor 70, 80, 81, 85; Figure Ground 27,

32, 34; Perceptual Constancy 2, 5, 7, 15, 25, 26, 30, 35, 36, 37, 45, 60; Position in Space 1, 7, 11, 22, 25; Spatial Relations 9, 33, 51, 61, 72. Use the Frostig Teacher's Guide, (14), for specific directions.

Auditory: Continue the routines established in the previous weeks adding new activities varied to meet the intended purpose of this unit wherever possible.

Visual Memory: Read over the PURPOSES and GUIDELINES on pages 66-70. Adapt activities in consideration of materials readily available until others can be provided or constructed by the leader with the help of the child involved. Include some activities with the circle, square and rectangle that have already been introduced.

Stepping Stones: Placement of "stones" around a triangle in this manner covering about a 10 foot area. Check directions according to pages 71-73.

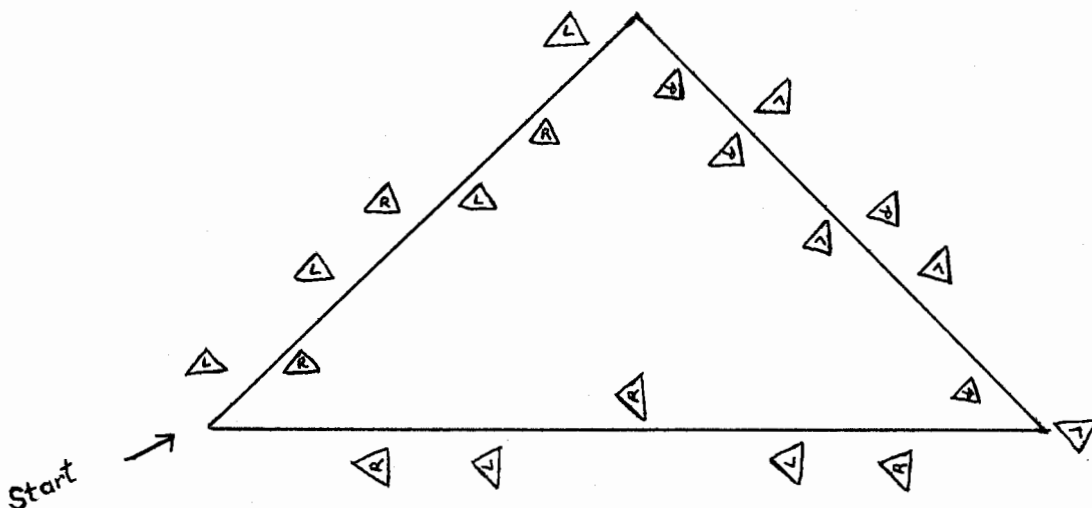

Final Group Activity: Refer to page 74.

## THE DIAMOND:

The diamond develops the transfer of changes in directionality and the awareness in differences from horizontal to vertical strengthening closure continuity.

Beginning Group: Review PURPOSES and GUIDELINES on pages 20-24. Plan appropriate activities in relation to the number of individuals participating and the intended shape.

Jumpboard: If four boards are available, arrange them in a diamond shape observing the diagonal approach to each corner. Continue activities in sequence around all four boards, pausing at each corner. Eye targets should be diamonds.

Balance Beam: If four beams are available, arrange them into a diamond observing the diagonal approach to each corner. Continue activities in sequence around all four boards, pausing at each corner.

Eye-Hand Coordination: Refer to pages 45-52 and adjust activities according to the child's needs and the unit's purpose for maximum effectiveness in manipulative skills. Have the child keep materials in his box or folder. Construct this form with toothpicks and mount on paper.

Pencil-Paper Tasks: Consult pages 53-59. Correlate Frostig sheets: Visual Motor 64; Perceptual Constancy 51, 52, 53, 59; Position in Space 2; Spatial Relations 77, 78, 79. Use the Frostig Teacher's Guide, (14), for specific directions.

Auditory: Continue the routines established in the previous weeks adding new activities varied to meet the intended purpose of this unit wherever possible.

Visual Memory: Consider the introduction of new activities or increase the scope of those already presented as the child responds and accomplishes the tasks presented to him. Adapt #3, page to include the circle, square, rectangle, and triangle along with the diamond.

Stepping Stones: Placement of "stones" around a diamond to cover about a 6 foot area.

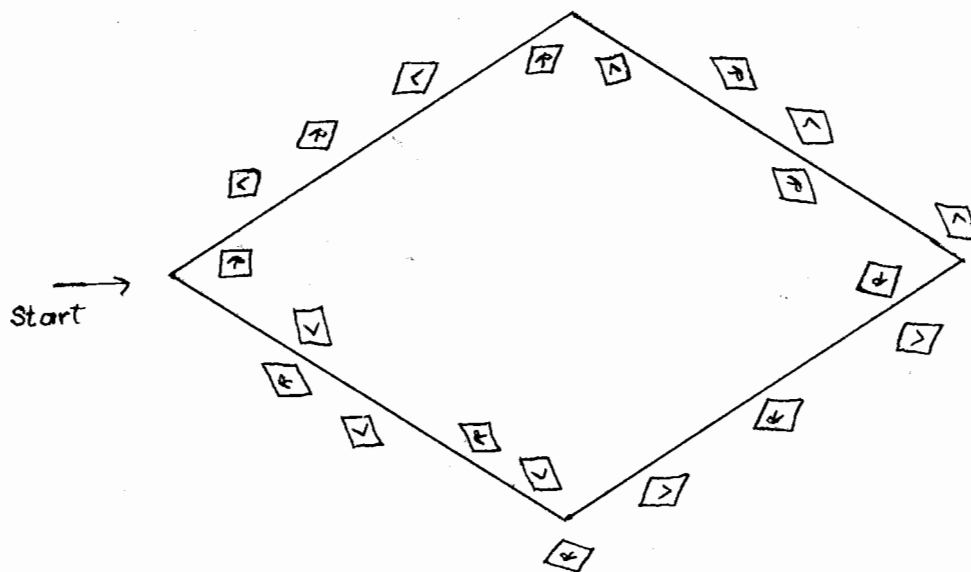

Final Group Activity: Refer to page 74.

ALL SHAPES:

A culmination of all geometric forms presented allows adaptation of form concept input to be applied to various related tasks.

Beginning Group: Suggested procedures on pages 20-24.

Jumpboard: Incorporate planning with the intended child to determine his ideas on the activities that should be repeated.

Balance Beam: Review any of the planned activities or introduce jumping rope.

Eye-Hand Coordination: Consult pages 45-52. Verbal review of Shape Book, #2, page 46 if this was carried out. Encourage the child to talk about all things that have accumulated in his box and folder. See interlocking forms, #6, page 47. Review other activities relating each to all shapes presented.

Pencil-Paper Tasks: Correlate Frostig sheets: Figure Ground 6, 10, 19, 40, 52; Perceptual Constancy 4, 21, 38, 39, 40, 41, 46, 47, 48, 49, 58, 63, 65, 70; Spatial Relations 10, 18, 19, 20, 22, 23, 24, 29, 36, 41, 42, 43, 44, 45, 46, 47, 48, 49, 50, 54, 59, 73, 82, 83, 84; Position in Space 6, 10, 24. Use the Frostig Teacher's Guide (14) for specific directions.

Auditory: Adapt #10, page 64, to include all forms. Adapt #11, page 64, to include all forms by using them in different sizes and colors.



Visual Memory: Continue #1 on page 66 including all variations. Disk is available reviewing these forms for #8, page 69. Try all shapes in #10, page

Stepping Stones: Placement of stones may vary as well as the shape of the stones. Children may cut the five shapes from construction paper as for other stepping stone activities.

Children may experiment with activities presented in the stepping stones calling out the shape while matching the right foot with the color designated for it and the left foot in its designated place.

Children may find a real learning experience in placing the stones in different patterns and then trying the plan to see if it will or will not work when being stepped out and discovering why.

Final Group Activity: Formation of all shapes presented in reaction to both verbal and visual stimuli.

CHAPTER IV

## CHAPTER IV

### PROGRAM INDIVIDUALIZED FOR STUDENT NEEDS

"Learning is a personal matter which involves a change in perception" (11:110). The necessary factor in visual training is the arrangement for the conditions of this learning. We have to know what the conditions for each individual are before structuring the learning situation to meet these needs. Visual perception disabilities will be reflected in a child's work and in his behavior because of his many failures.

By observation of the child as he performed tasks presented to him during the thirteen weeks of BEEP, Basic Educational Experiences Program, (6), a teacher gained insight as to his position in basic learning skills and perception needs. In addition to this, the following test results further indicated individual needs of pupils: (1) Primary Mental Abilities Test, (2) Frostig Test of Visual Perception, and (3) Winterhaven Geometric Form Evaluation. The intent was to provide useful screening tools to the classroom teacher, principal, perceptual, consultant and student leader in identifying children needing training provided in the Experience Units of Phase II.

A close examination of the current learning level of the child was compiled as a Perceptual Motor Survey sheet. (See page 97.) With this information along with any available test results, a desired direction could be indicated so that training would be planned accordingly.

All of the activities within a given Experience Unit would not be appropriate for every child taking part in the program. Because of individual differences in needs depending upon the area of learning adjustment, the following descriptions of operationally defined perceptual skills serve as a guidance key for individualized programming.

A child's prescribed training is most meaningful when the intended pencil-paper task is preceded by personal body involvement and understanding of the relationship to the task. Manipulative materials and body movement activities directed towards the performance expected provide the child an awareness and functional background for successful achievement.

Characteristics of the Five Visual Perceptual Abilities  
Relevant to Classroom Learning  
and  
Suggested Training Areas

1. Visual-Motor Coordination: "Visual-motor coordination is the ability to coordinate vision with movements of the body or with movements of a part or parts of the body. Whenever a sighted person reaches for something, his hands are guided by his vision." (14:16)

This control is prerequisite for the development of printing, writing, and drawing skills. The ability to coordinate hand and eye movements with speed as well as accuracy is important in pencil-paper task achievement.

Children having defective or poorly developed visual-motor coordination often have difficulty in running, jumping, stepping over things, carrying objects and even performing the simple daily tasks of dressing or getting in and out of familiar areas. Because of many failures this child is likely to have a poor self-concept and learning ability.

A lag in visual-motor control may be aided by pencil and paper tasks, along with coloring, cutting and pasting activities. The two dimensional operational processes, however, should be preceded by gross motor control activities as found in the following areas: balance beam, beginning group activity, stepping stones, jumpboard, eye-hand manipulative tasks and chalkboard opportunities.

2. Figure-ground: "A child with poor figure-ground discrimination characteristically appears to be inattentive and disorganized. This is because his attention tends to jump to any stimulus that intrudes upon him...to something that moves or glitters or is brightly colored, for instance...no matter how irrelevant it may be to what he should be doing" (14:20).

If he cannot perceive an object in different surroundings, which is basic to figure-ground perception, he may have trouble in games and sports. In reading or writing the child may change the position of a word or lose his place because the word does not stand out. His letter attempts are incorrect, he skips and confuses familiar problems seeming to be careless.

Training in this area should include: beginning group activities, eye-hand coordination and manipulative procedures,

pencil-paper tasks (particularly those designed in the figure-ground area), and visual memory. The jumpboard, balance beam, stepping stones, and auditory discrimination should be included. The training sessions on one particular area should be kept short and lengthened gradually to maintain attention and strengthen the span of concentration.

3. Perceptual Constancy: "Perceptual constancy is the ability to perceive an object as possessing invariant properties, such as shape, position, and size, in spite of the variability of the impression on the sensory surface" (14:34). In order for the child to be successful he must thus recognize the object no matter what the position or distance viewed, the color, size, style of print, or the varied context in which it might be presented.

Words well known in one list may be foreign when found in new content. Learning to read or to work with symbols becomes discouraging. Exercises are needed to develop the child's ability to generalize with regard to visual material.

A well-developed program for perceptual constancy should include: eye-hand manipulative materials concentrating on matching with varying sizes and colors of the same article, word or object; building a pattern from a given plan; pencil-paper tasks in the perceptual constancy activities as well as chalkboard experiences with provision for active participation in gross motor control activities as those outlined in the beginning group along with

some gross motor involvement. Auditory discrimination and visual memory suggestions should be included.

4. Perception of Position in Space: "Perception of position in space may be defined as perception of the relationship of an object to the observer. Spatially, at least, a person is always the center of his own world and perceives objects as being behind, before, above, below, or to the side of himself" (14:40).

A child having difficulty here may reverse numbers and letters. Body awareness is often lacking. He may be clumsy or hesitant and not be able to balance himself in a given position. This is an important ability in art and handcraft activities.

The program for children needing training in the position in space should include: beginning group activities, jumpboard, balance beam, stepping stones, manipulative tasks and pencil-paper tasks especially those involving position in space.

5. Perception of Spatial Relationships: "The perception of spatial relationships is the ability of an observer to perceive the position of two or more objects in relation to himself and in relation to each other" (14:74). This helps the child's ability to perceive positional relationships like the order of letters in a word, digits in a number, or the arrangement of material on a page. This ability has a direct bearing on the child's performance in reading, especially with longer words, and in computations since he must remember the arrangement of numbers.

It is recommended that a child having difficulty in this area be assigned to: beginning group activities, eye-hand manipulative tasks, pencil-paper tasks (particularly involving spatial relationships, stepping stones and auditory discrimination.)

Perceptual Motor Survey - An Inventory of Individual Programming

The following PERCEPTUAL MOTOR SURVEY, (see page 97) was designed to provide a guideline in inventoring a child's needs. With this information individual programs can be planned for the child involved in Phase II of the Basic Educational Experiences Program.



## CHAPTER V

## SUMMARY, CONCLUSIONS AND RECOMMENDATIONS

Summary

The guidelines and procedures in this program were written with the intent that teachers, principals, specialists and student leaders might better understand the perceptual needs of children. The program was planned to provide the best possible individual learning situations for each child and his needs. "The goal of all teachers must be to provide the learner with those opportunities and experiences which will enable him to transport himself physically and cognitively, in comfort and ease so as to promote his optimal survival. . . he is a space traveler seeking the route to competency. . . as are we all." (2:333)

The program was applied to the total learning situation and more specifically to the perceptual development of children. Detailed suggestions were outlined in sequential experience units of perceptual organization including gross and fine motor control activities.

Conclusion

As children referred from the first three grades in school took part in Phase II of the Basic Educational Experiences Program, it was hoped that the scope of body movement experiences and self-realization activities was broadened. Thus they were provided with opportunities to explore and adjust to the phases of their

immediate needs and future challenges. Since behavior is reasonable and purposeful, the individual would use better or more ways in reacting or behaving if he knew them. "We must know how each individual perceives his situation subjectively, not objectively. The concern here is to understand the field of operation and all of its interrelationships." (11:187)

It was hoped that children would gain a smoother, more accurate approach to learning situations, an understanding of skills necessary to successful achievement and a higher degree of motivation to function efficiently and confidently in their total environment. "When visual steering, coordinated bilateral motor actions, audition, touch and speech are integrated, elaborated, reinforced and repeated, the children are being physiologically prepared for the world of school. This is readiness in action!" (15:40)

### Recommendations

Working with classroom teachers in the perceptual program revealed a need for more information to be provided in teacher orientation and education in this area of learning. Districts are beginning to provide in-service training but the basic awareness should come from the teacher training institutions.

The inclusion of perceptual training within the total curriculum planning would ease the decisions of the classroom teacher in justifying a time for this activity. A further study in the values of auditory and visual perception programs in the primary grades in curriculum development would help to determine its place.

The utilization of high school students as student leaders in the Basic Educational Experience Programs produced the following problems: (1) lack of communication between the classroom teachers and the student leaders because of a limited time element, and (2) transportation difficulties of students going to and from the elementary schools. Coordination of the elementary school's program to a high school curriculum plan demanded full attention.

Relationships that developed between student leaders and the children as well as between student leaders and the total school personnel were most beneficial for all concerned. The student leaders received limitless training and opportunities that gave them a total new outlook on themselves within a possible professional vocation.

The entire area of older students helping younger students should be more fully explored and studied as to open all possible avenues of learning for both sets of students.

PERCEPTUAL MOTOR SURVEY

Date \_\_\_\_\_

Child's Name \_\_\_\_\_ Age \_\_\_\_\_ Grade \_\_\_\_\_ School \_\_\_\_\_

Teacher \_\_\_\_\_

Merely estimate how you feel this child is doing in I and II below. It is not anticipated that you will retest them in any of these skills. Place an X in the appropriate column.

|  | O.K. | Needs Help | Poor |
|--|------|------------|------|
| <b>I. Gross Motor Skills</b>   |      |            |      |
| 1. Balance and Posture<br>(Walking Beam & Jump Board)                          |      |            |      |
| 2. Body Image and Differentiation<br>(Identifies Body Parts & Stepping Stones) |      |            |      |
| 3. Perceptual-Motor Match<br>(Chalkboard & classroom observations)             |      |            |      |
| 4. Ocular Control<br>(As observed in Ocular Pursuits & in classroom)           |      |            |      |
| 5. Form Perception<br>(Classroom observation of drawing, writing, etc.)        |      |            |      |
| 6. Right-left orientation<br>(Reversals - writing, reading)                    |      |            |      |
| 7. Listening Skills<br>(Attentional controls)                                  |      |            |      |
| <b>II. Fine Motor Skills</b>   |      |            |      |
| 1. Visual Memory<br>(Copies accurately from board)                             |      |            |      |
| 2. Spatial Relationships<br>(Can write on line)                                |      |            |      |
| 3. Figure Ground<br>(Not distracted by unrelated pictures, sounds, etc.)       |      |            |      |

III. Have the child draw a picture of a person and attach it to this sheet. To be interpreted by Student Personnel Services staff.

IV. Attach the seven geometric drawings also. To be interpreted by S.P.S. staff.  
(Available from Student Personnel Services)

B I B L I O G R A P H Y

## BIBLIOGRAPHY

1. American Educational Research Association. Department of the National Education Association. Encyclopedia of Educational Research, Third Edition. New York: The MacMillan Company pages 701 - 705, 941 - 945, 1960.
2. Barsch, Ray H. Achieving Perceptual-Motor Efficiency. Seattle: Special Child Publications, 1967.
3. Barsch, Ray H. A Moviogenic Curriculum. Yakima: Yakima County for Cooperative Program for Special Education, 46 pages, August 1967.
4. Bloom, Benjamin S. Stability and Change in Human Characteristics. New York: John Wiley and Sons, Incorporation, 1964.
5. Borislow, B. "Self-evaluation and Academic Achievement," Journal of Counseling Psychology, pages 246 - 254, 1962.
6. Brackett, Delores and Stapleton, Peg. Basic Educational Experiences Program. Yakima: Yakima Public Schools, January 1968.
7. Brownlee, Philip and Banks, Elaine. "Organizing to Learn", Pasco Program of Organized Motor Learning. Pasco: Pasco School District Number 1, 1968.
8. Combs, C. F. "Perception of Self and Scholastic Underachievement in the Academically Capable," Personnel and Guidance Journal, pages 43, 47-51, 1964.
9. Coombs, A. and Snygg D. Individual Behavior, Revised Edition. New York: Harper and Row, Publishers, Incorporation, 1959.

10. Cruickshank, William M. Psychology of Exceptional Children.  
New Jersey: Prentice Hall, 1963.
11. Dinkmeyer, Don. Child Development: The Emerging Self.  
New Jersey: Prentice Hall, 1965.
12. Elind, David. "Piaget and Montessori", The Education Digest.  
Ann Arbor Michigan: Prakken Publications, Inc.,  
pages 43-46, March 1968.
13. Frostig, Marianne; Lefever, Welty and Whittlesey, John R.  
Administration and Scoring Manual - Marianne Frostig  
Developmental Test of Visual Perception. Palo Alto:  
Consulting Psychologists Press, 1964.
14. Frostig, Marianne and Horne, David. Teacher's Guide, The  
Frostig Program for the Development of Visual Perception.  
Chicago: Follett Publishing Company, 1964.
15. Getman, G. N. and Kane, Elmer R. The Physiology of Readiness.  
Minneapolis: Programs to Accelerate School Success, 1964.
16. Getman, G. N. Kane E. R.; Halgran, Marvin R. and McKee, Gordon  
W. Developing Learning Readiness - Teacher's Manual.  
St. Louis: Webster Division, McGraw-Hill Book Company, 1968.
17. Jenkins, Gladys G.; Shacter, Helen S., and Bauer, William W.  
These Are Your Children. Palo Alto: Scott, Foresman and  
Company, pages 1 - 153, 1966.
18. Kephart, Newell C. The Slow Learner in the Classroom. Columbus  
Charles E. Merrill Books, Inc., 1960.
19. Kephart, Newell C. An address to the Council for Exceptional  
Children, Seattle, March 15, 1968.
20. Miner, Adah. "Teaching Listening in the Elementary School"  
Shoreline Curriculum Guide. Seattle: Shoreline Public  
Schools, 4 pages, 1964.
21. Mould, Richard W. An Evaluation of the Effectiveness of a  
Special Program for Retarded Readers Manifesting Distributed  
Visual Perception. Washington State University: A thesis  
submitted in partial fulfillment of the requirements for  
the degree of Doctor of Education, 1965.
22. Norton, M. Scott. "After Project Head Start - What Next?"  
The Elementary School Journal. Chicago: The University  
of Chicago Press, January 1967.
23. Percepta-Matic. Perceptual Organization and the Teacher.  
Portland: Percepta-Matic, 1964.

24. Piaget, Jean. The Origins of Intelligence in Children. New York: International Universities Press, 1966.
25. Powell, Marion B. "The Social Desirability Aspect of Self-concept in Relation to Achievement and Creativity", Dissertation Abstracts, 25 (3), 2054, 1964.
26. Radler, D. H., and Kephart, Newell C. Success Through Play. New York: Harper and Brothers, 1960.
27. Sterritt, Graham and Rudnick, Mark. "Auditory and Visual Rhythm Perception in Relation to Reading Ability in Fourth Grade Boys", Perceptual and Motor Skills. 22:859-64, 1966.
28. Scott, Louise Binder. Learning Time with Language Experiences for Young Children. St. Louis: Webster Division, McGraw-Hill Book Company, 1968.
29. Watson, Robert I. Psychology of the Child. New York: John Wiley and Sons, Incorporation, Second Edition, 1965.
30. Winter Haven Lions Club. Perceptual Forms. Winter Haven; The Star Press, 1963.



23 Henry Drive  
Yakima, Wa. 98902  
August 10, 1968

Dr. Newell C. Kephart  
Department of Psychology  
Purdue University  
Purdue, Indiana

Dear Dr. Kephart:

As I took notes during your presentation in Seattle on March 15 of this year, I did not fully realize the personal impact of the information. I am a perceptual training teacher for Yakima Public Schools with Dr. Richard Mould's Student Personnel Services Department.

I am now involved in writing a program in sequential perceptual activities that will be developed as a follow-up to the Basic Educational Experience Program written by myself and Mrs. Delores Brackett. Phase II of this program, which I am writing in correlation with a Master's Program at Central Washington State College, will contribute to and support the perceptual needs of the individual child. Phase I is a minimal basic program.

In reviewing the literature in gathering material and information for this program, I keep coming back to your speech and always to your publications, particularly to The Slow Learner in the Classroom. I feel before I can adequately begin the thesis content that Chapter I would not be complete without the information you presented.

It is so difficult to listen and capably quote at the same time and it has been 5 months since this meeting. I have written the material in the manner you see enclosed. Would you grant permission for its usage in this thesis?

I would value any corrections or additions and would appreciate any comments.

I surely hope that you will soon be back in the Pacific Northwest area so that those of us who were privileged to hear you can do so again and those who were not able to do so, may have the opportunity.

Sincerely yours,

Mrs. Peg Stapleton

*Glen Haven Achievement Center*

Post Office Box 2153  
Fort Collins, Colorado 80521

August 27, 1968

Mrs. Peg Stapleton  
23 Kenny Drive  
Yakima, Washington 93902

Dear Mrs. Stapleton:

Your letter concerning the use of material from my presentation in Seattle in your thesis has been forwarded to me. I have gone over this material and have made some corrections as you will note on the enclosed. It is quite satisfactory for you to use this material in your thesis.

Since my visit to Seattle, I have terminated my affiliation with Purdue University in order to establish a clinical facility for children with learning disabilities in Fort Collins, Colorado. The enclosed brochure will describe for you the program at the Glen Haven Achievement Center.

Thank you very much for your interest in our work and in our publications.

Cordially yours,

N. C. Kephart, Ph.D.  
Director

Please note:

Signature has been removed due to security concerns