

## BEAM PHASE MEASUREMENT OF STORED BUNCH

Takashi Ohshima\*, Akihiro Yamashita, JASRI/SPring-8, Hyogo, Japan  
 Masamichi Yoshioka, SPring-8 Service co., Ltd., Hyogo, Japan

### Abstract

We developed a system to measure synchronous phase angles for all bunches in the storage ring using an oscilloscope with high sampling rate. Precise phase measurement of specific bunch is required from the synchrotron radiation (SR) users, especially from the time resolved spectroscopy users. In a pump and probe experiment, the trigger timing for pumping laser should be precisely adjusted to the probe SR light. The timing of the SR light is affected by gap positions of insertion devices, filling pattern, bunch currents and so on. At the SPring-8, the bunch currents and the synchronous phase angles for all stored bunches are measured within 10seconds. The precision of the phase angle is about 5pico seconds. Combining this system with an averaged synchronous phase measurement system, we are now preparing to deliver the information of the synchronous phase angle to the SR users.

### INTRODUCTION

The SPring-8 is a third generation X-ray source. One of its unique features is almost constant bunch current with top-up operation [1]. Another one is very low impurity for single bunch. Owing to these features pump and probe experiments with high precision are done at the SPring-8. In those experiments precise trigger signals are required for pumping lasers, which have to be set at a strict timing relative to the probing X-ray beam timing. The timing of the X-ray is subject to the parameters such as gap positions of insertion devices (ID). So we have to measure the synchronous phase angle for specific bunch used for the experiment.

The bunch length of the stored beam is about 40ps. So the aimed precision for the monitor system is about 5ps, which corresponds to about 1 degree of 508.58MHz RF phase. As for the acquisition time of the monitor system, it should be less than 4seconds. The synchronous phase angles are determined by the ratio of the RF accelerating voltage and the energy loss per turn. The RF voltage is constant during the user operation time. The energy loss by the bending magnets is constant and is 9.2MeV/turn. The energy loss by IDs is depending on their gap positions and maximum loss is about 2MeV/turn. The movement of the gap position is done by mechanical way so they have a time constant of the order of several seconds. We observed the change of the beam phase by 7degrees in 30 seconds just before starting the user time, when the gap positions of IDs were moved to minimum values to check their functions. So the required acquisition time is about 4 seconds to monitor the change of the synchronous phase angle of 1 degree. In the

\*ohshima@spring8.or.jp

following shows the measurement setup and achieved performance of the detector.

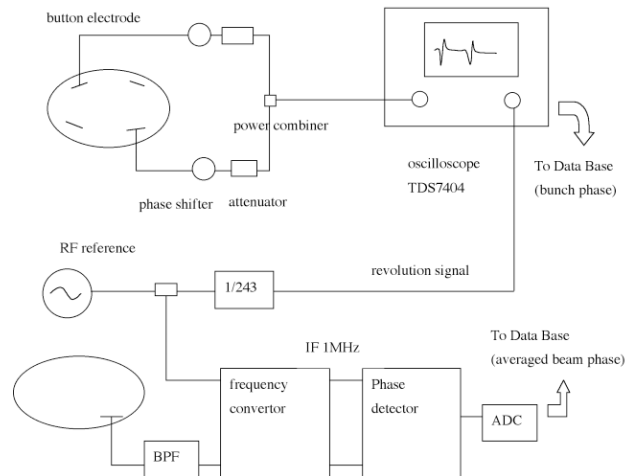

Figure 1. Measurement setup for the beam phase.

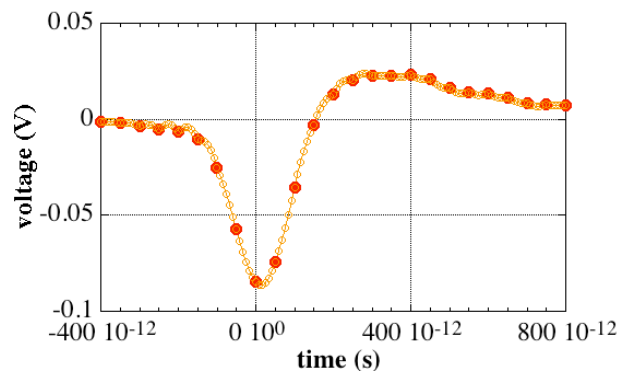

Figure 2. An example of pickup signal measured by an oscilloscope TDS7404B.

### MEASUREMENT CONFIGURATION

The beam current monitor was developed for injection control with a top-up operation [2]. Its precision is better than 1%. It consists from button pickup electrodes and an oscilloscope with high sampling rate as shown in Fig. 1. It can be also utilized to measure both the bunch current and synchronous phase angle for each bunch (bunch phase monitor). The peak voltage of the signal induced by the bunch at the pickup electrode is proportional to the bunch current and the timing at the peak of the signal corresponds to the synchronous phase angle. We also prepared another synchronous phase measurement system, which is used to measure the phase angle averaged over whole stored bunch (averaged beam phase monitor).

At the averaged beam phase monitor, the signal from a button pickup electrode is passing through a narrow band

pass filter whose centre frequency is 508.58MHz and bandwidth is 1MHz. The pickup signal and the RF reference are down converted to intermediate frequency of 1MHz. Then the signal is detected by a phase detector. The bandwidth of the phase detector is 100 kHz, which is lower than the revolution frequency of the ring 208 kHz. The phase angle is stored to data base system every one second.

At the bunch current and phase monitor, the signal from another button electrode is directly fed to an oscilloscope. To minimize the effect from beam motions in transverse directions, the beam signals from electrodes attached to the vacuum chamber in diagonal position are summed up. The analogue bandwidth of the scope TDS7404B is 4GHz and the sampling rate is 20Gs/s. The revolution signal is generated by a synchronous counter, which continuously counts the 508.58MHz RF clock to the harmonic number of the ring 2436, and the signal is used for the trigger of the scope. The revolution time of the storage ring is about 4.8 $\mu$ s so the number of data points is about 100k points. The data is averaged out for 100 times on the oscilloscope to improve the vertical resolution because that of the oscilloscope is only 8bit. An example of the pulse signal induced by the beam is shown in Fig. 2. Its pulse width is about 300ps, which is determined by the capacitance of the pick up electrode. The sampling rate of 20Gs/s is not enough to evaluate the minimum voltage of the peak. The peak may be lost from the sampling. So we make interpolation by using  $\sin(x)/x$  function and the equivalent sampling rate becomes 120Gs/s. Fig. 2 also shows both the measured points (filled circle) and interpolated points (open circle). The peak voltage of the signal is almost proportional to the bunch current and the timing of the peak is considered as a bunch phase. The bunch phase is recorded as a deviation from the bunch spacing determined by the RF frequency. These calculations are done by the cpu inside the oscilloscope and bunch currents and beam phases are transferred to the data base system through Ethernet. One measurement is done within about 10seconds.

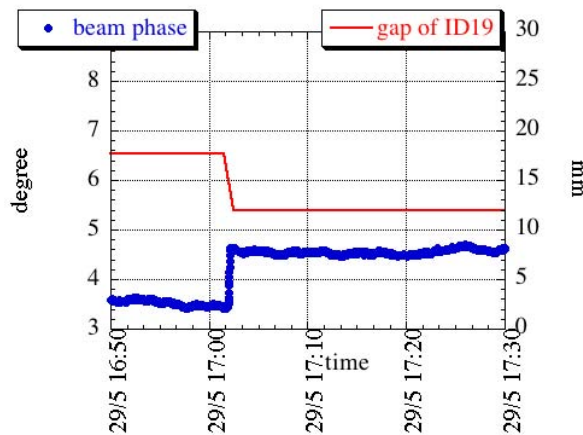

Figure 3. The averaged beam phase and a gap position of ID19.

## RESULTS

The synchronous phase angle is affected by the energy loss by the insertion devices. Because SR users at the SPring-8 can freely change the gap positions, we cannot know when the energy loss will be changed. This causes fluctuation of the timing for the pump and probe experiment. Fig. 3 shows an example of change of synchronous phase angle averaged over all bunches at a user time. According to the change of a gap position of ID19 the angle is changed about 1.2 degree, in this case.

The synchronous phase angle is also affected by a filling pattern. There are many kinds of filling patterns for user operation at the SPring-8. Fig. 4 shows an example of synchronous phase angles for the 203 equally spaced filling pattern measured by using the bunch phase monitor. The bunch current is about 0.5mA and the bunch phases are almost constant near 0 degree. In this case the bunch phases have almost same value to the averaged one. Fig. 5 shows another example at a filling pattern of 18 single bunches and successive 232 bunch train. The bunch currents of the singles are 1.5mA and those for bunch train are about 0.3mA. The beam phases are varied for about 10 degrees because the acceleration voltage is reduced at the bunch train section by the heavy beam loading and the voltage is gradually recovered at the single bunches section. At this filling pattern the timing of probing X-ray (synchronous phase angle) is depending on which bunch is used for the SR experiment and maximum phase deviation is about 10 degrees.

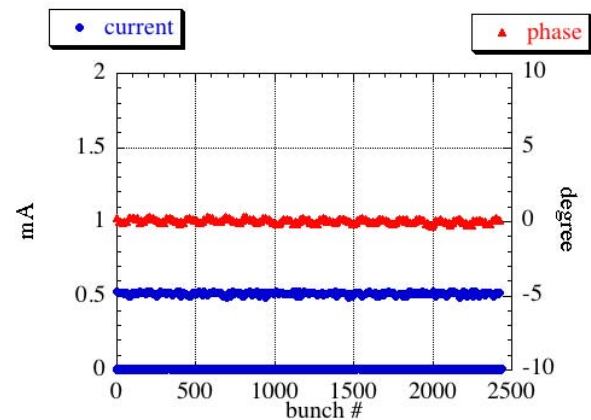

Figure 4. Bunch current and bunch phase for 203 equally spaced filling.

Two phase measurement systems, averaged beam phase monitor and bunch phase monitor, have merit and demerit. The bunch phase monitor has a relatively long acquisition time of 7 seconds. And the resolution of the bunch phase monitor is about one degree. The averaged phase monitor has better resolution around 0.2degree and short data acquisition time less than 1ms. So we are preparing a timing distribution system shown in Fig. 6. The revolution signal and RF signal are fed to the experimental hatch through optical fibre or hard wire. And the beam phase is transfer through data base system, where the bunch phase data is used as an offset and the averaged beam phase data

is used for compensation of the RF phase fed to the laser timing controller in the pump and probe experiment.

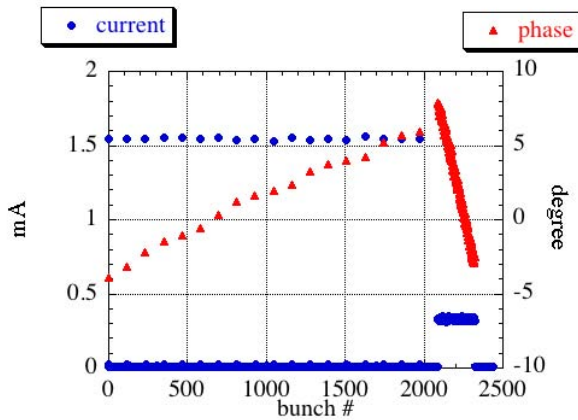

Figure 5. Bunch current and bunch phase for a filling pattern of 18 singles and 232 bunch trains.

There are some problems in our timing distribution system. One thing is drift of the phase due to temperature variation. The averaged beam phase monitor uses frequency down converters and a narrow band pass filter. And they have dependence on the ambient temperature of about 1 degree per 1 Kelvin. We are planning to introduce a temperature control system to keep the monitor temperature constant.

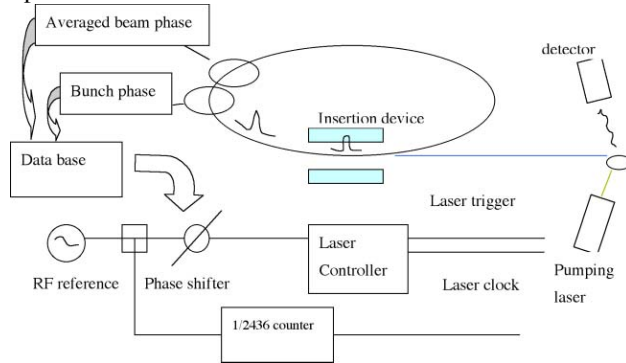

Figure 6. Timing driver system for pump and probe user.

An attempt was tried to store the beam with the energy of 4GeV instead of nominal energy of 8GeV [3, 4]. In this case the damping time becomes long and longitudinal instabilities are observed. To overcome this instability, a modulation of accelerating voltage was applied; where acceleration voltage of 3MV was produced with nominal RF frequency while 1MV was applied with nominal RF frequency plus one revolution frequency. The RF voltage is modulated in one turn and the synchrotron frequency is changed according to the bunch address. Applying this RF modulation we could successfully accumulate 100mA beam current.

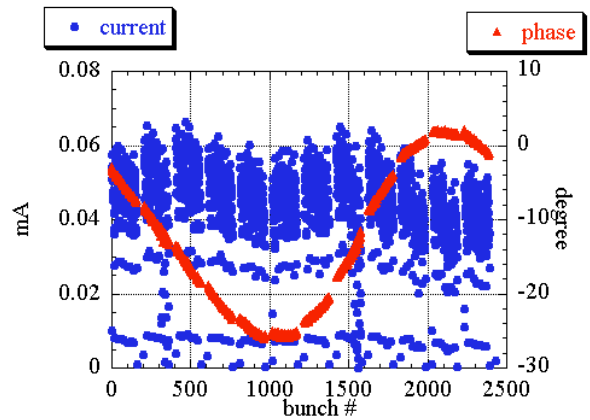

Figure 7. Bunch current and bunch phase with RF voltage modulation at 4GeV operation.

### SUMMARY

We developed a bunch current and phase measurement system. The measured current is used for injection at top up operation. The beam phase is measured with a resolution of 1 degree. The averaged beam phase is also measured and both the bunch phase and averaged beam phase will be informed to the SR user and will be utilized for their experiment.

### ACKNOWLEDGEMENTS

The authors thank to Dr T. Masuda for his work to communicate between the oscilloscope and the database. They also thank to Y. Tanaka, Y. Fukuyama and J. Kim for their useful discussion on user's needs of timing signal. They thank to T. Ohata and T. Hirono for their help on communication between the accelerator control LAN and the beam line control LAN.

### REFERENCES

- [1] H. Tanaka, et. al., "Top-up Operation of SPring-8 Storage Ring with Low Emittance Optics", this conference.
- [2] T. Ohshima, et. al., "Top-up injection control using bunch current monitor at SPring-8", Proceedings of Particle Accelerator Society of Japan, Saga, Japan, Jul. 2005.
- [3] K. Soutome, et. al., "Present Status of Low-Energy Test Operation at SPring-8", to be presented on Particle Accelerator Society of Japan, Sendai, Japan, Aug. 2006.
- [4] T. Nakamura et. al., "Cure of Longitudinal Instability by Acceleration Voltage Modulation by Revolution", to be presented on Particle Accelerator Society of Japan, Sendai, Japan, Aug. 2006.