

Beyond DCG: User Behavior as a Predictor of a Successful Search

Ahmed Hassan¹, **Rosie Jones**², and **Kristina Klinkner**³

¹University of Michigan Ann Arbor



²Yahoo! Labs



³Carnegie Mellon University



User Satisfaction

“ If you cannot measure it,
you cannot improve it.”

William Thomson, Lord Kelvin
(1824-1907)



Which is Better?

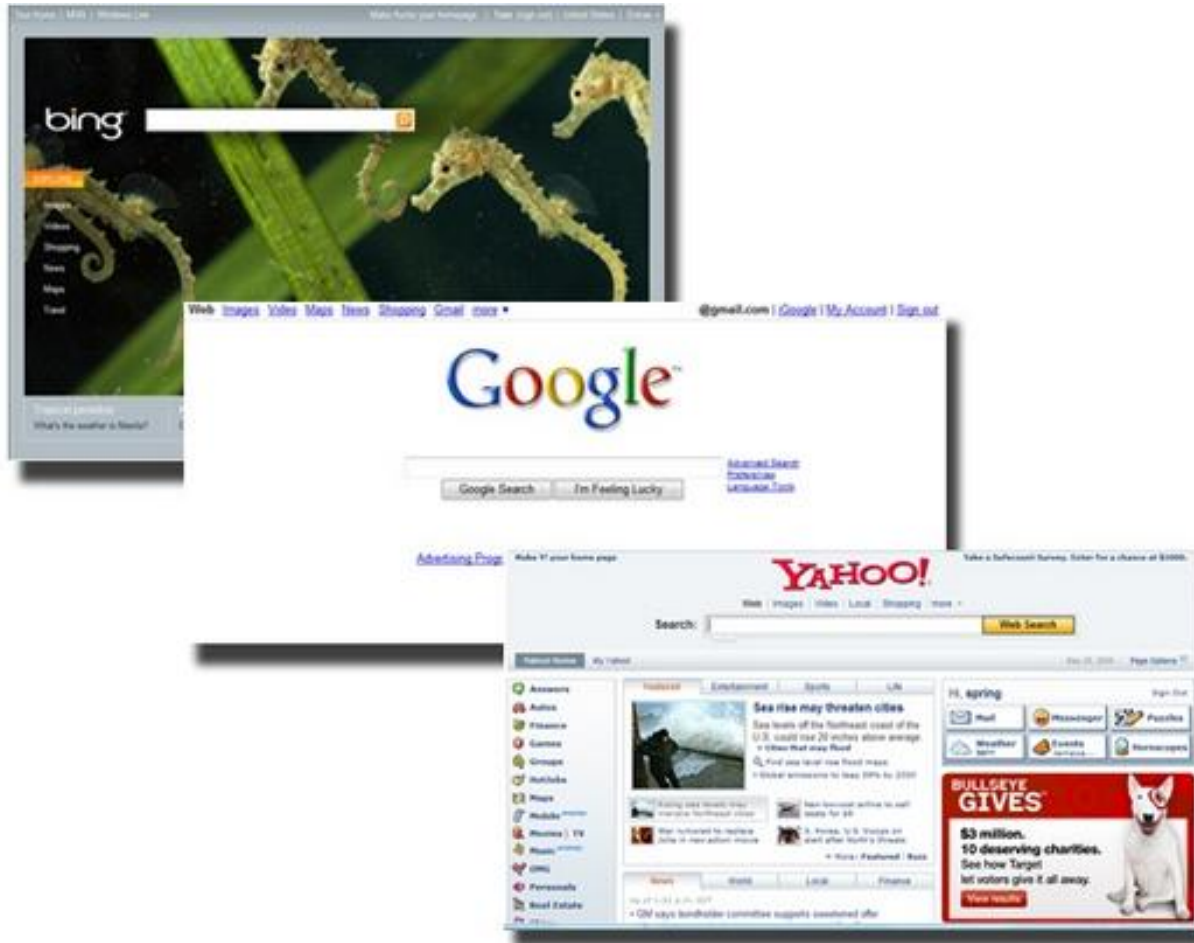

New vs. Old

Web Images Videos Maps News Shopping Gmail more ▾

Google Search [Advanced Search](#)

Web [Show options...](#)

Results 1 - 10 of about 21,700,000 for playoffs. (0.27 seconds)

News results for playoffs



TV ratings up for first day of NFL playoffs - 27 minutes ago
The first day of the NFL playoffs drew the best preliminary television ratings in a decade. The Cowboys' 34-14 win over the Eagles on NBC on Saturday night ...

[BusinessWeek](#) - 1738 related articles »

The Jets Can Only Hope You Remain Bored By The NFL Playoffs -

[New York Magazine](#) - 71 related articles »

Ring on the Jets - 50 [Bolt Report](#) - 133 related articles »

NFL 2009 Playoff Race - CBSsports.com

During the regular season, the seeds reflect how the playoffs would stand if the season ended ... The NFL playoffs are not based on a pure bracket system. ...

[www.cbssports.com/nfl/standings/playoffrace/seeds](#) - [Cached](#)

NFL Schedule Playoffs

Playoff Picture Wild-Card Round Sat.-Sun., Jan. 9-10; AFC: Sat., Jan. 9

N.Y. Jets: Cincinnati Sun., Jan. 10, 1:00 p.m. ET CBS ...

[www.nfl.com/schedule?seasonType=POST](#) - [Cached](#) - [Similar](#)

Sponsored Links

[NFL Playoff Schedule](#)

Go Inside the 2010 NFL Playoffs w/ Schedules, Scores, & Predictions. [Fanhouse.com](#)

[NFL Playoff Schedule](#)

NFL Playoff Schedule & More! 100,000 Stores. Deals. Reviews. [shopping.yahoo.com](#)

[NFL Playoff Schedule](#)

Search for NFL Playoff Schedule. Find NFL playoff schedule.

Google

Search

About 21,600,000 results (0.30 seconds)

[Advanced search](#)

Everything

Videos

News

Images

Blogs

Updates

Books

Maps

Shopping

Forums

Less

News for playoffs



The Jets Can Only Hope You Remain Bored By The NFL Playoffs - 34 minutes ago

Of the eight teams left in the playoffs, six of them are openly offense-oriented, and considering the two that aren't, the Jets and Ravens, ...

[New York Magazine](#)

After Patriots blow out of playoffs, has Boston's title reign ended? - [SI.com](#)

Cowboys' Jones exercises demons of playoffs past - [Washington Post](#)

Latest results for playoffs - [Pause](#)

Making these lists have made me realize that there are a lot of Tweeps who disappeared right before the MLB playoffs.

[@seeshiz](#) - [twitter.com](#) - 1 minute ago

[@whatsthe](#) 2 years? Love is gone after next year if no playoffs! Bears need rebuilding everywhere!

[@cheapsports](#) - [twitter.com](#) - 1 minute ago

Miss some of the action this weekend, catch up with Rex's NFL Playoffs update from...

Sponsored links

[NFL Playoff Schedule](#)

NFL Playoff Schedule & More! 100,000 Stores. Deals. Reviews. [shopping.yahoo.com](#)

[NFL Playoff Schedule](#)

Find the Best Results for NFL Playoff Schedule. Ask.com! [www.Ask.com](#)

See your ad here »

Web Search is Interactive

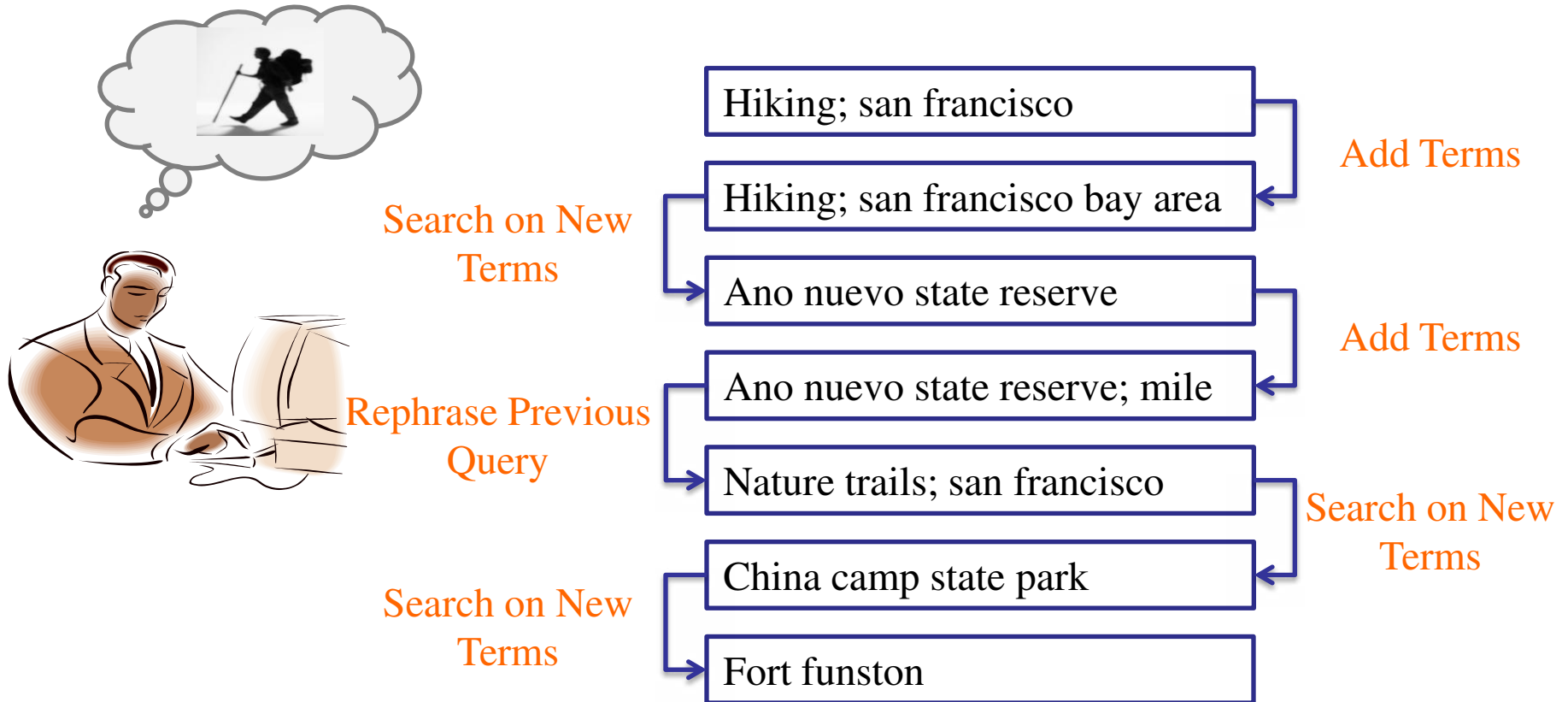

Web Search is Interactive



Hiking; san francisco	Red
Hiking; san francisco bay area	Green
Ano nuevo state reserve	Red
Ano nuevo state reserve; mile	Green
Nature trails; san francisco	Red
China camp state park	Green
Fort funston	Green

Web Search is Interactive



Hiking; san francisco

Hiking; san francisco bay area

Ano nuevo state reserve

Ano nuevo state reserve; mile

Nature trails; san francisco

China camp state park

Fort funston

**Learned about
three hiking areas**

Web Search is Interactive



Hiking; san francisco

Hiking; san francisco bay area

TASK AS CONTEXT

Ano nuevo state reserve

Ano nuevo state reserve; mile

PREDICT TASK SUCCESS

Nature trails; san francisco

China camp state park

Fort funston

Clickstream Data

Web | [Images](#) | [Video](#) | [Local](#) | [Shopping](#) | [more](#) ▾

[Options](#) ▾ [Customize](#) ▾

YAHOO!

1 - 10 of 832,000,000 for guess (About) - 0.03 s | SearchScan^{BETA} On

Also try: [guess watches](#), [guess clothing](#), [guess who](#), [More...](#)

SPONSOR RESULTS

[GUESS® Official Site](#)

Get The Hottest New Apparel In The 2009 GUESS® Collection.
[GUESS.com](#)

[Guess@' Macy's](#)

Find the Latest Collection of Designer Clothing Online at Macy's.
[Macy's.com/guess](#)

[GUESS: Home](#)

GUESS is about sexy, adventurous, trendsetting apparel and accessories. ... © GUESS, Inc. 2009 All Rights Reserved. [Privacy Policy](#) - [Terms & Conditions](#) ...
[shop.guess.com](#) - 553k - [Cached](#)

Stores	Gift Cards
Shopping Bag	Customer Services
Guess	My Wish List
Customer Care	Track Order

[more results from shop.guess.com »](#)

SPONSOR RESULTS

[Guess Brand Shoes at Low Prices](#)

Find a great deal on a stlyish new pair of shoes at Become today!
[Guess.Become.com/Shoes](#)

[Guess on Sale](#)

Save on **Guess** \$5, \$10, or \$15 Off (Select Stores).
[RetailBerry.com/guess](#)

[The Guess at Amazon](#)

Low prices on new & used music. Qualified orders over \$25 ship free.
[Amazon.com/music](#)

Actions: Q 4s

Clickstream Data

Web | [Images](#) | [Video](#) | [Local](#) | [Shopping](#) | [more](#) ▾

[Options](#) ▾ [Customize](#) ▾

YAHOO!

1 - 10 of 832,000,000 for guess (About) - 0.03 s | SearchScan^{BETA} On

Also try: [guess watches](#), [guess clothing](#), [guess who](#), [More...](#)

SPONSOR RESULTS

[GUESS® Official Site](#)
Get The Hottest New Apparel In The 2009 GUESS® Collection.

[Guess@' Macy's](#)
Find the Latest Collection of Designer Clothing Online at Macy's.
[Macys.com/guess](#)

[GUESS: Home](#)
GUESS is about sexy, adventurous, trendsetting apparel and accessories. ... © GUESS, Inc. 2009 All Rights Reserved. Privacy Policy - Terms & Conditions ...
[shop.guess.com](#) - 553k - [Cached](#)

[Stores](#) [Gift Cards](#)
[Shopping Bag](#) [Customer Services](#)
[Guess](#) [My Wish List](#)
[Customer Care](#) [Track Order](#)

[more results from shop.guess.com »](#)

SPONSOR RESULTS

[Guess Brand Shoes at Low Prices](#)
Find a great deal on a stlyish new pair of shoes at Become today!
[Guess.Become.com/Shoes](#)

[Guess on Sale](#)
Save on **Guess** \$5, \$10, or \$15 Off (Select Stores).
[RetailBerry.com/guess](#)

[The Guess at Amazon](#)
Low prices on new & used music. Qualified orders over \$25 ship free.
[Amazon.com/music](#)

Pattern: Q 4s RL 1s

Clickstream Data

Web | Images | Video | Local | Shopping | more ▾

guess watches Options ▾ Customize ▾

YAHOO!

1 - 10 of 47,400,000 for guess watches (About) - 0.03 s | SearchScan^{BETA}

Also try: [men's guess watches](#), [guess watches singapore](#), [More...](#)

GUESS® Watches  SPONSOR RESULTS
Get The Hottest New **Watches** In The 2009 GUESS® Collection.
[GUESS.com](#)

[Women's Guess Watches - Huge Sale](#)
Compare prices on all name brand **watches**. Compare - Shop - Save.
[Guess.Become.com/watches](#)

[Guess Watch at Amazon.com®](#)
Large Selection Of **Watches** In Stock. Free Shipping On Orders Over \$25.
[www.amazon.com/watches](#)

[Guess Watches](#)
Includes product information, webcams, a global clock, web postcards, and more.
[www.guesswatches.com](#) - [Cached](#)

[Guess Watches - BizRate.com](#)
Find **Guess Watches** at bargain prices. Comparison shop for the lowest prices, check store ratings & read product reviews before you buy.
[www.bizrate.com/watches/brand--guess/products__att259--257458-.html](#)

[Guess Watches - NexTag.com](#)
Compare Cheap Prices for **Guess Watches** at NexTag.com. Find Bargain Fashions and the Latest Styles from Name-Brand Designers of Clothing, Jewelry, and Accessories.
[www.nextag.com/Guess--2702409/brand-html](#)

[Guess Watches](#)
Compare Prices and Save at SHOP.COM.
[www.SHOP.com](#)

[Guess Watch](#)
Get the best deals on all **guess watch**.
[shopbig.com/watches](#)

[Guess Watch](#)
Bid on **Guess Watch** now! Find **Watches**.
[www.eBay.com](#)

[Guess Watch](#)
Shop for **Watches**. Compare Prices, Buy & Save Online.
[BottomDollar.com/watches](#)

[Guess Gold Watches](#)
Save Up To 80% Off **Guess Gold**

Pattern: Q 4s RL 1s SR 53s

Clickstream Data

Web | Images | Video | Local | Shopping | more ▾

guess watches Search Options ▾ Customize ▾

YAHOO!

1 - 10 of 47,400,000 for guess watches (About) - 0.03 s | SearchScan^{BETA}

Also try: [men's guess watches](#), [guess watches singapore](#), [More...](#)

GUESS® Watches  SPONSOR RESULTS
Get The Hottest New Watches In The 2009 GUESS® Collection.
[GUESS.com](#)

[Women's Guess Watches - Huge Sale](#)
Compare prices on all name brand watches. Compare - Shop - Save.
[Guess.Become.com/watches](#)

[Guess Watch at Amazon.com®](#)
Large Selection Of Watches In Stock. Free Shipping On Orders Over \$25.
[www.amazon.com/watches](#)

[Guess Watches](#)
Includes product information, webcams, a global clock, web postcards, and more.
[www.guesswatches.com](#) - [Cached](#)

[Guess Watches - BizRate.com](#)
Find **Guess Watches** at bargain prices. Comparison shop for the lowest prices, check store ratings & read product reviews before you buy.
[www.bizrate.com/watches/brand--guess/products__att259--257458-.html](#)

[Guess Watches - NexTag.com](#)
Compare Cheap Prices for **Guess Watches** at NexTag.com. Find Bargain Fashions and the Latest Styles from Name-Brand Designers of Clothing, Jewelry, and Accessories.
[www.nextag.com/Guess--2702409/brand.html](#)

[Guess Watches](#)
Compare Prices and Save at SHOP.COM.
[www.SHOP.com](#)

[Guess Watch](#)
Get the best deals on all **guess watch**.
[shopbig.com/watches](#)

[Guess Watch](#)
Bid on **Guess Watch** now! Find **Watches**.
[www.eBay.com](#)

[Guess Watch](#)
Shop for **Watches**. Compare Prices, Buy & Save Online.
[BottomDollar.com/watches](#)

[Guess Gold Watches](#)
Save Up To 80% Off **Guess Gold**

Pattern: Q 4s RL 1s SR 53s SR 118s END

Clickstream Data

- Action sequence \rightarrow Graph.

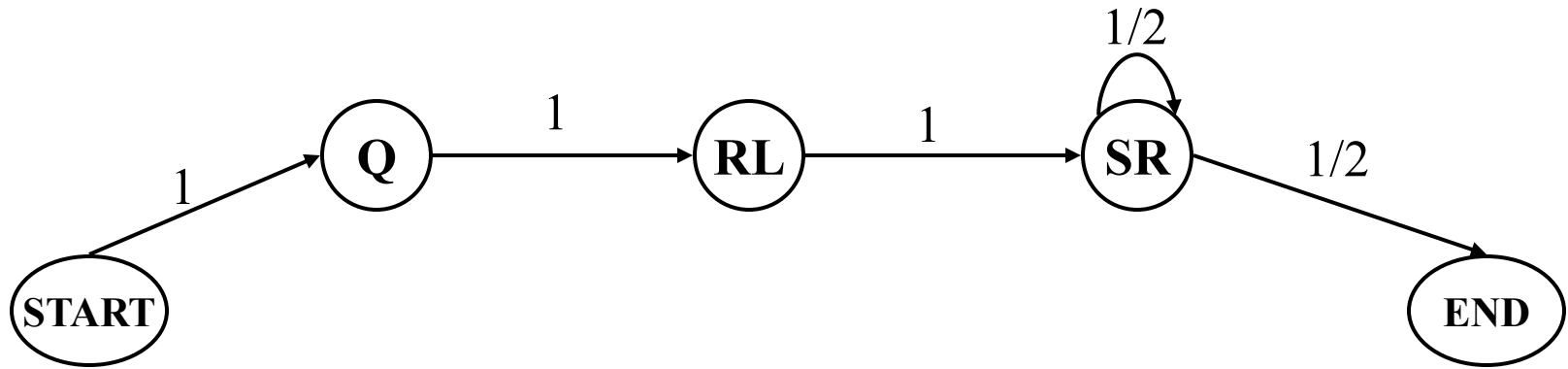

Goal 1: Q 4s RL 1s SR 53s SR 118s END

Clickstream Data

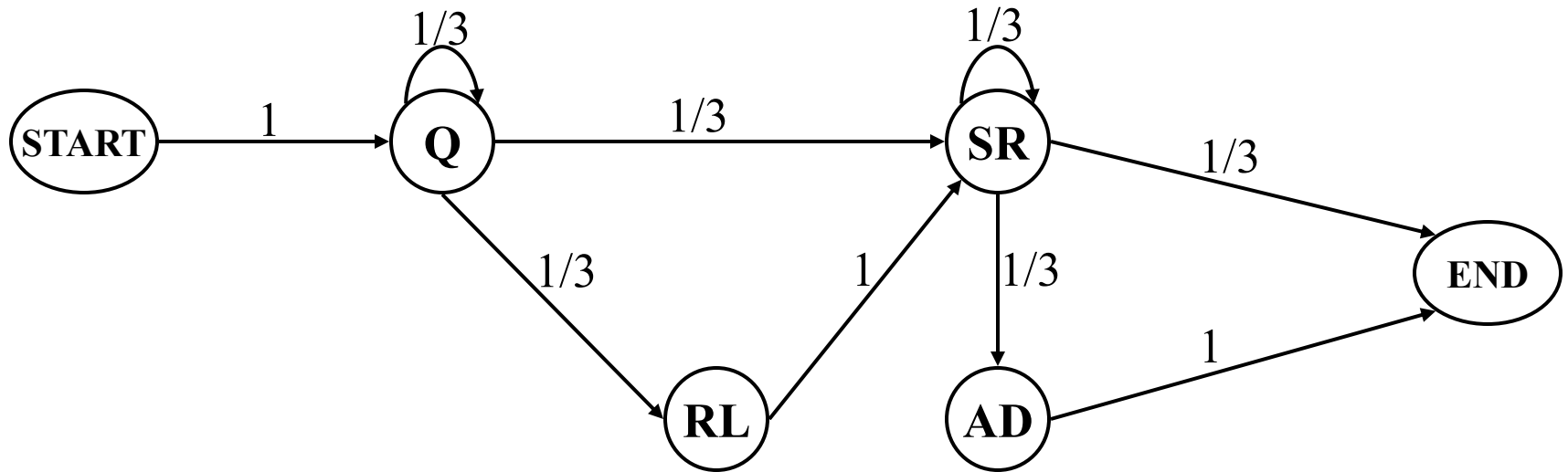

Goal 1: Q 4s RL 1s SR 53s SR 118s END

Goal 2: Q 3s Q 5s SR 10s AD 44s END

Modeling User Sessions

- Each set of goals may be represented by a first order Markov Model:

Goal₁: Q 4s RL 1s SR 53s SR 118s END
 Goal₂: Q 3s Q 5s SR 10s AD 44s END
 Goal₃: Q 4s RL 1s SR 53s SR 118s END
 Goal₄: Q 3s Q 5s SR 10s AD 44s END

 Goal_n: Q 4s RL 1s SR 53s SR 118s END
 Goal_{n-1}: Q 3s Q 5s SR 10s AD 44s END

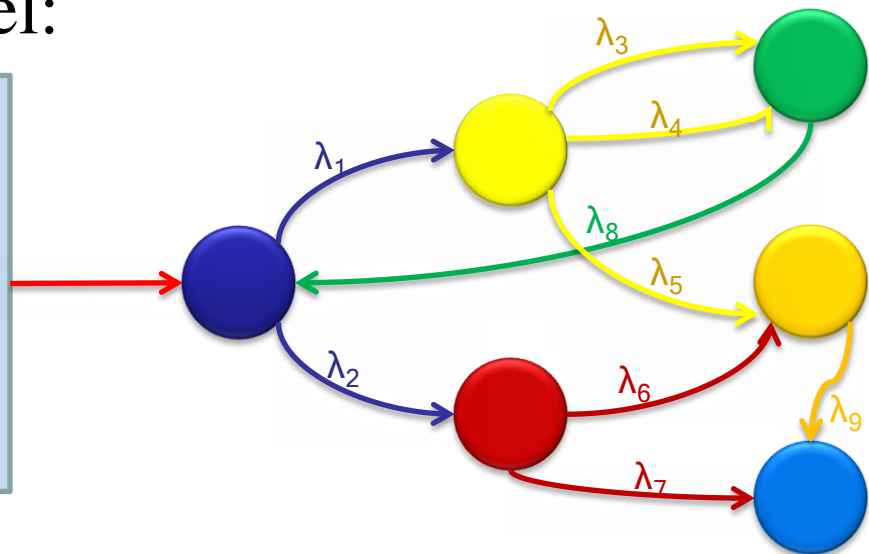

- Small state space: $\{Q, SR, AD, SC, RL, SP, OTH\}$
- Transition Probabilities: $\Pr(i, j) = \frac{Q_{i,j}}{Q_i}$

Markov Model

- Build two models:

Successful Goals

Goal 1: Q 4s RL 1s SR 53s SR 118s END
Goal 2: Q 3s Q 5s SR 10s AD 44s END
Goal 3: Q 4s RL 1s SR 53s SR 118s END
Goal 4: Q 3s Q 5s SR 10s AD 44s END
.....
Goal n: Q 4s RL 1s SR 53s SR 118s END
Goal n-1: Q 3s Q 5s SR 10s AD 44s END

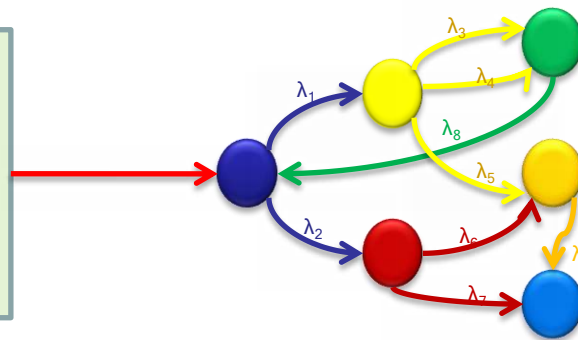

Unsuccessful Goals

Goal 1: Q 4s RL 1s SR 53s SR 118s END
Goal 2: Q 3s Q 5s SR 10s AD 44s END
Goal 3: Q 4s RL 1s SR 53s SR 118s END
Goal 4: Q 3s Q 5s SR 10s AD 44s END
.....
Goal n: Q 4s RL 1s SR 53s SR 118s END
Goal n-1: Q 3s Q 5s SR 10s AD 44s END

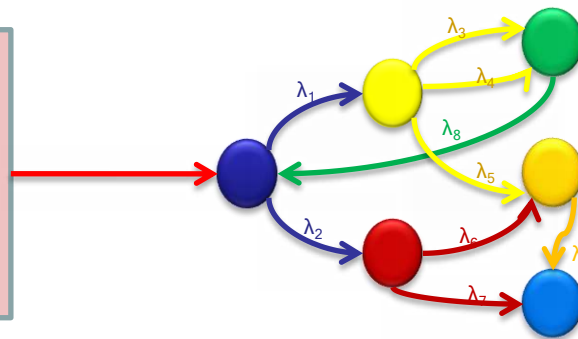

Classifying New Goals

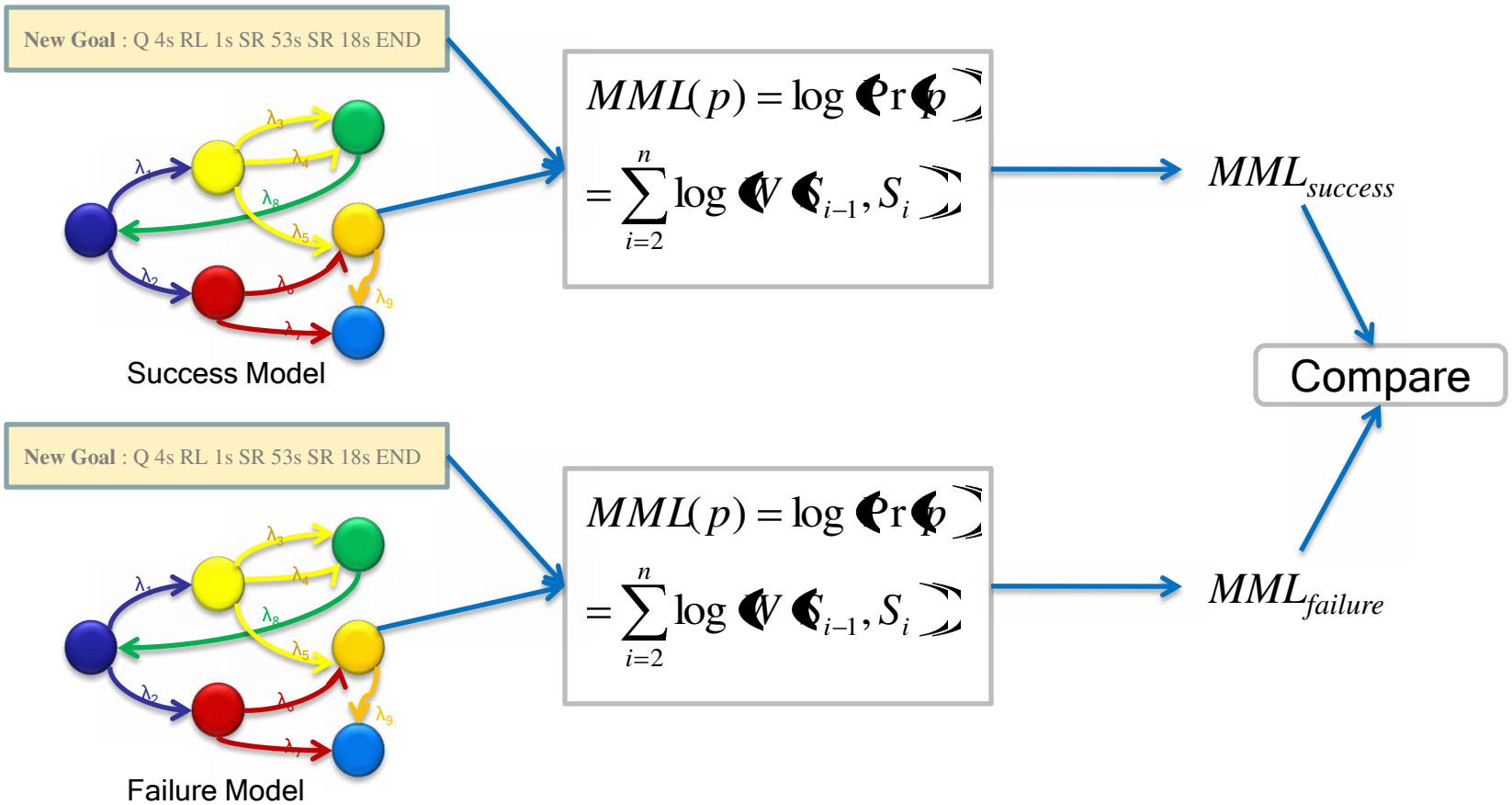

Modeling Time

- Attach a time distribution to each transition in the Markov chain.

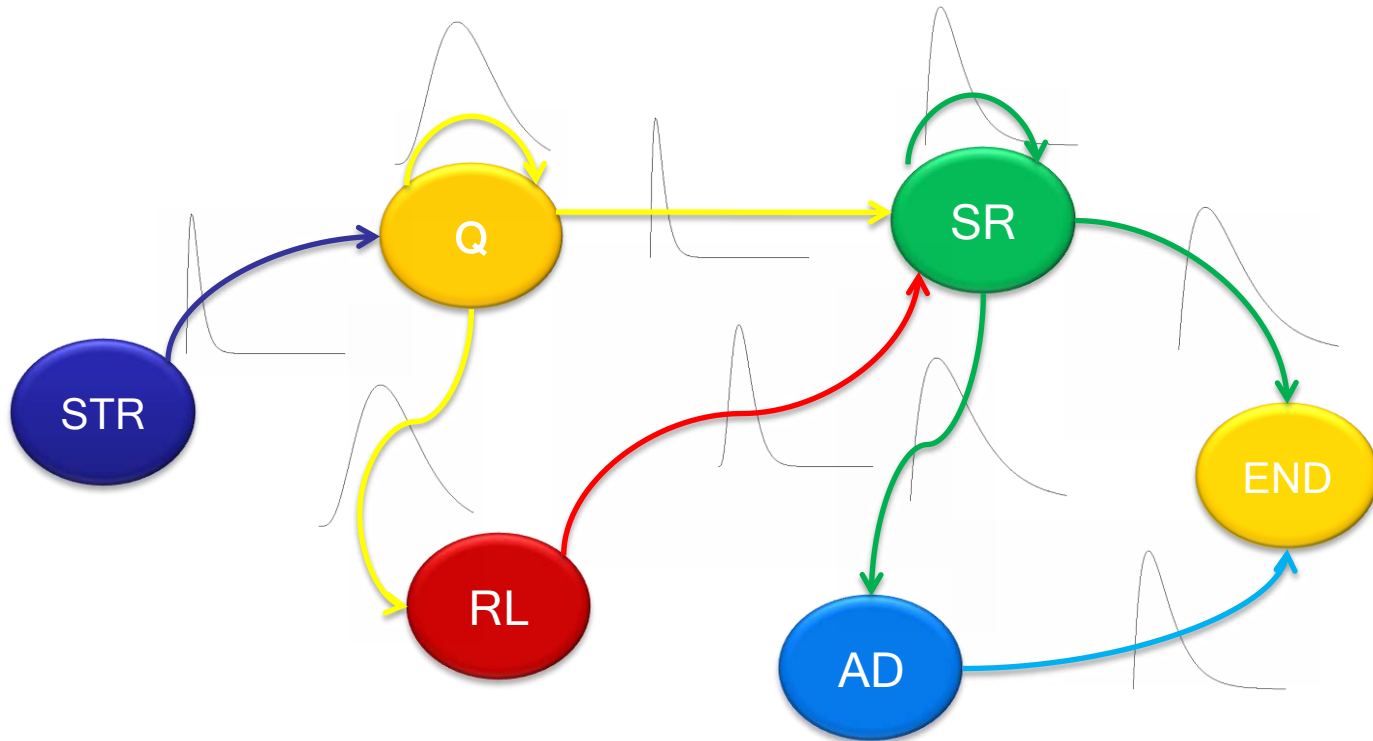

Markov Models Do Much Better Than Baseline

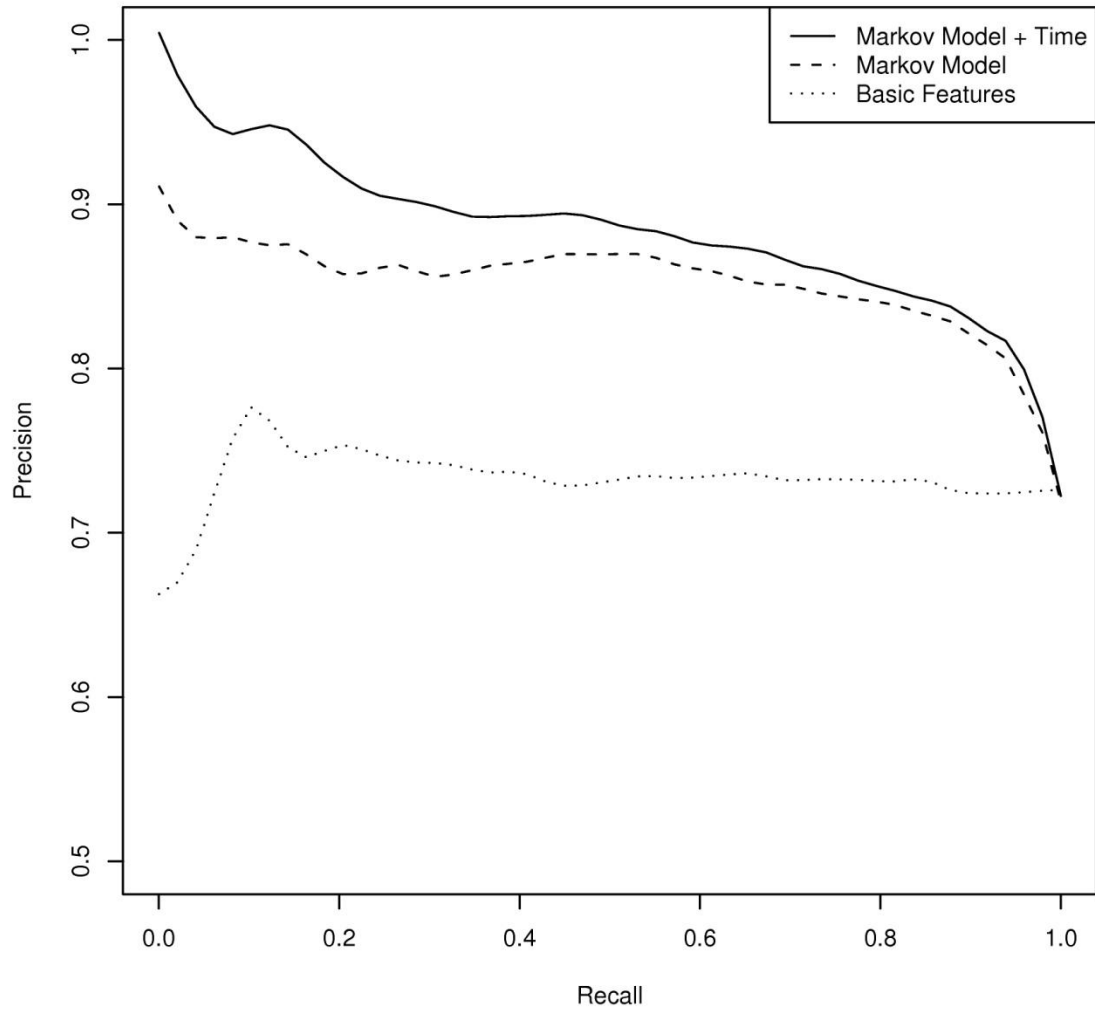

User Behavior Outperforms Relevance based Prediction

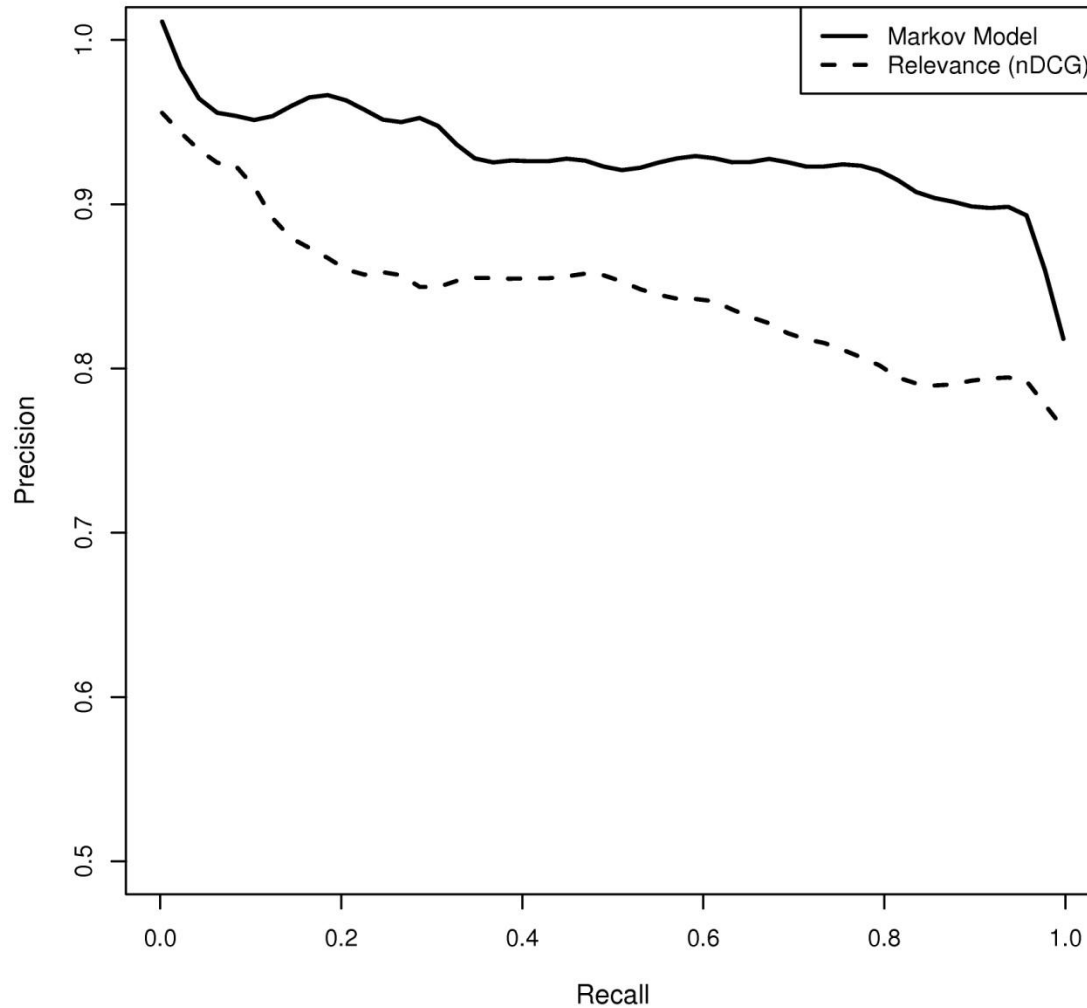

Successful Goals More Likely to Use Shortcuts

Action following query		Odds-ratio
SC	Shortcut	2.0
SR	Search result	1.8
RL	Also-Try	1.2
SP	Spell-correction	0.9
Q	Query	0.5
END	End of goal	0.1

Odds-ratio of transitions from query to other actions in successful goals, compared to unsuccessful goals.

Highly Probable Successful Paths

Highly probable successful paths
Q SR END
Q SR SR END
Q SR SR SR END
Q SR SR SR SR END
Q AD END
Q SC END
Q SR Q SR SR END

Highly Probable Unsuccessful Paths

Highly probable unsuccessful paths
Q END
Q Q END
Q OTH END
Q SR Q END
Q Q Q END
Q RL END
Q Q SR Q SR Q END

Conclusions and Future Work

- Predict success using a Markov model that captures user behavior
- We can predict goal success with 82% accuracy
- The Markov model outperforms relevance based models
- Build other predictive models for sessions

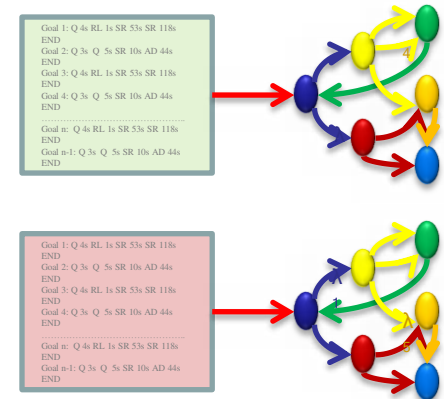

Questions?

Ahmed Hassan

hassanam@umich.edu