



LUND UNIVERSITY

Bicycle Dynamics and Control

Åström, Karl Johan; Klein, Richard E.; Lennartsson, Anders

Published in:
Control Systems Magazine

DOI:
[10.1109/MCS.2005.1499389](https://doi.org/10.1109/MCS.2005.1499389)

2005

[Link to publication](#)

Citation for published version (APA):

Åström, K. J., Klein, R. E., & Lennartsson, A. (2005). Bicycle Dynamics and Control. *Control Systems Magazine*, 25(4), 26-47. <https://doi.org/10.1109/MCS.2005.1499389>

Total number of authors:
3

General rights

Unless other specific re-use rights are stated the following general rights apply:

Copyright and moral rights for the publications made accessible in the public portal are retained by the authors and/or other copyright owners and it is a condition of accessing publications that users recognise and abide by the legal requirements associated with these rights.

- Users may download and print one copy of any publication from the public portal for the purpose of private study or research.
- You may not further distribute the material or use it for any profit-making activity or commercial gain
- You may freely distribute the URL identifying the publication in the public portal

Read more about Creative commons licenses: <https://creativecommons.org/licenses/>

Take down policy

If you believe that this document breaches copyright please contact us providing details, and we will remove access to the work immediately and investigate your claim.

LUND UNIVERSITY

PO Box 117
221 00 Lund
+46 46-222 00 00

Bicycle Dynamics and Control

By Karl J. Åström,
Richard E. Klein, and
Anders Lennartsson

Adapted bicycles for
education and research



This article analyzes the dynamics of bicycles from the perspective of control. Models of different complexity are presented, starting with simple ones and ending with more realistic models generated from multibody software. We consider models that capture essential behavior such as self-stabilization as well as models that demonstrate difficulties with rear wheel steering. We relate our experiences using bicycles in control education along with suggestions for fun and thought-provoking experiments with proven student attraction. Finally, we describe bicycles and clinical programs designed for children with disabilities.

The Bicycle

Bicycles are used everywhere—for transportation, exercise, and recreation. The bicycle's evolution over time has been a product of necessity, ingenuity, materials, and industrialization. While efficient and highly maneuverable, the bicycle represents a tantalizing enigma. Learning to ride a bicycle is an acquired skill, often obtained with some difficulty; once mastered, the skill becomes subconscious and second nature, literally just “as easy as riding a bike.”

Bicycles display interesting dynamic behavior. For example, bicycles are statically unstable like the inverted pendulum, but can, under certain conditions, be stable in forward motion. Bicycles also exhibit nonminimum phase steering behavior.

Bicycles have intrigued scientists ever since they appeared in the middle of the 19th century. A thorough presentation of the history of the bicycle is given in the recent book [1]. The papers [2]–[6] and the classic book by Sharp from 1896, which has recently been reprinted [7], are good sources for early work. Notable contributions include Whipple [4] and Carvallo [5], [6], who derived equations of motion, linearized around the

LOUIS MCCLELLAN/THOMPSON-MCCLELLAN PHOTOGRAPHY

vertical equilibrium configuration, based on Lagrangian dynamics. The book [8] and its third edition [9] give a broad engineering perspective. Rankine, Klein, and Sommerfeld analyze bicycles in [2] and [10]. Papers appear regularly in the scientific literature [11]–[23]. The first publications that used differential equations to describe the motion of an idealized bicycle appeared toward the end of the 19th century. During the early 20th century, several authors studied the problems of bicycle stability and steering. Neimark and Fufaev [24] derived a comprehensive set of linearized models by approximating potential and kinetic energy by quadratic terms and applying Lagrange’s equations to these expressions. The analysis in [24], which modeled wheels both as ideal disks and pneumatic tires, is elaborated in [25].

Modeling bicycles became a popular topic for dissertations in the latter half of the last century [26]–[32]. One of the first computer simulations of a nonlinear bicycle model was presented in [33]. Nonlinear models are found in [23] and [34]–[36], in which the dynamic order ranges 2–20, depending on the assumptions made. Simple models of bicycle dynamics are given in the textbooks [37]–[39]. Early models were derived by hand calculations. Software for multibody systems [40]–[45] simplifies modeling significantly and permits more detailed modeling, as described in the dissertations [46], [47].

Bicycles share many properties with motorcycles [49]. The high-order motorcycle models in [50] and [51] also include tire slip and frame elasticity. Rider models are used to study handling characteristics [28], [18]. A comprehensive discussion of motorcycle models is given in [52], which provides a detailed treatment of tire-road interaction. A high fidelity model of motorcycle dynamics that includes vibrational modes is given in [53], and models based on multibody software are found in [54] and [55].

Several attempts have been made to develop autopilots for bicycles and motorcycles. In particular, [56] describes a complete controller for a motorcycle, including results from practical tests. Autopilots are also described in [34], [35], and [57]–[59].

The bicycle provides an ideal venue for illustrating modeling, dynamics,

stabilization, and feedback. This system also illustrates the fundamental limitations on control caused by poles and zeros in the right-half plane. These limitations can be demonstrated by simple experiments. In fact, special bicycles with highly spectacular properties can be designed, making the bicycle well suited to activities for K–12 education, open houses, and demonstrations. Adaptive bicycles for teaching children with disabilities to ride bicycles have also been developed in [60] and [61] (see “Adapted Bicycles for Teaching Children with Disabilities”).

Modeling

When modeling a physical object, it is important to keep the purpose of the model in mind. In this article, we develop bicycle models and use them to analyze balancing and steering problems.

A detailed model of a bicycle is complex because the system has many degrees of freedom and the geometry is intricate. Some important aspects to consider are the choice of bicycle components to include in the model, the treatment of elasticity of the bicycle parts, the modeling of tire-road interaction, and the complexity of the rider model. Successful control and maneuvering of a bicycle depend critically on the forces between the wheels and the ground. Acceleration and braking require longitudinal forces, whereas balancing and turning depend on lateral forces. A good understanding of these forces is necessary to make appropriate assumptions about valid models of the rolling conditions.

We assume that the bicycle consists of four rigid parts, specifically, two wheels, a frame, and a front fork with handlebars. The influence of other moving parts, such as pedals, chain, and brakes, on the dynamics is disregarded. To include the rider in the analysis, the rider’s upper body is modeled as a point mass that can move laterally with respect to the bicycle frame. The rider can also apply a torque to the handlebars.

When a rigid wheel rolls without sliding on a rigid surface, forces between the wheel and the ground are transferred without losses. In reality, the tire is deformed due to



the forces acting between ground and wheel. Since we do not consider extreme conditions and tight turns, we assume that the bicycle tire rolls without longitudinal or lateral slippage. Control of acceleration and braking is not considered explicitly, but we often assume that the forward velocity is constant. To summarize, we simply assume that the bicycle moves on a horizontal plane and that the wheels always maintain contact with the ground.

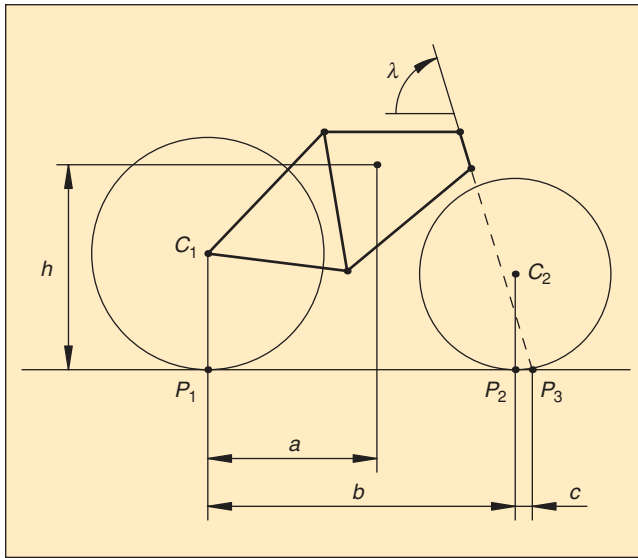

Figure 1. Parameters defining the bicycle geometry. The points P_1 and P_2 are the contact points of the wheels with the ground, the point P_3 is the intersection of the steer axis with the horizontal plane, a is the distance from a vertical line through the center of mass to P_1 , b is the wheel base, c is the trail, h is the height of the center of mass, and λ is the head angle.

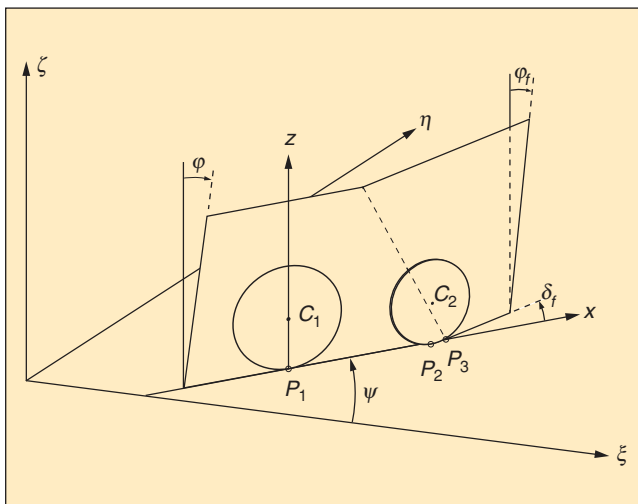

Figure 2. Coordinate systems. The orthogonal system $\xi\eta\zeta$ is fixed to inertial space, and the ζ -axis is vertical. The orthogonal system xyz has its origin at the contact point of the rear wheel with the $\xi\eta$ plane. The x axis passes through the points P_1 and P_3 , while the z axis is vertical and passes through P_1 .

Geometry

The parameters that describe the geometry of a bicycle are defined in Figure 1. The key parameters are wheelbase b , head angle λ , and trail c . The front fork is angled and shaped so that the contact point of the front wheel with the road is behind the extension of the steer axis. Trail is defined as the horizontal distance c between the contact point and the steer axis when the bicycle is upright with zero steer angle. The riding properties of the bicycle are strongly affected by the trail. In particular, a large trail improves stability but makes steering less agile. Typical values for c range 0.03–0.08 m.

Geometrically, it is convenient to view the bicycle as composed of two hinged planes, the frame plane and the front fork plane. The frame and the rear wheel lie in the frame plane, while the front wheel lies in the front fork plane. The planes are joined at the steer axis. The points P_1 and P_2 are the contact points of the wheels with the horizontal plane, and the point P_3 is the intersection of the steer axis with the horizontal plane (Figure 1).

Coordinates

The coordinates used to analyze the system, which follow the ISO 8855 standard, are defined in Figure 2. There is an inertial system with axes $\xi\eta\zeta$ and origin O . The coordinate system xyz has its origin at the contact point P_1 of the rear wheel and the horizontal plane. The x axis is aligned with the line of contact of the rear plane with the horizontal plane. The x axis also goes through the point P_3 , which is the intersection between the steer axis and the horizontal plane. The orientation of the rear wheel plane is defined by the angle ψ , which is the angle between the ξ -axis and the x -axis. The z axis is vertical, and y is perpendicular to x and positive on the left side of the bicycle so that a right-hand system is obtained. The roll angle φ of the rear frame is positive when leaning to the right. The roll angle of the front fork plane is φ_f . The steer angle δ is the angle of intersection between the rear and front planes, positive when steering left. The effective steer angle δ_f is the angle between the lines of intersection of the rear and front planes with the horizontal plane.

Simple Second-Order Models

Second-order models will now be derived based on additional simplifying assumptions. It is assumed that the bicycle rolls on the horizontal plane, that the rider has fixed position and orientation relative to the frame, and that the forward velocity at the rear wheel V is constant. For simplicity, we assume that the steer axis is vertical, which implies that the head angle λ is 90° and that the trail c is zero. We also assume that the steer angle δ is the control variable. The rotational degree of freedom associated with the front fork then disappears, and the system is

left with the roll angle φ as the only degree of freedom. All angles are assumed to be small so that the equations can be linearized.

Top and rear views of the bicycle are shown in Figure 3. The coordinate system xyz rotates around the vertical axis with the angular velocity $\omega = V\delta/b$, where b is the wheel base. An observer fixed to the coordinate system xyz experiences forces due to the acceleration of the coordinate system relative to inertial space.

Let m be the total mass of the system. Consider the rigid body obtained when the wheels, the rider, and the front fork assembly are fixed to the rear frame with $\delta = 0$, let J denote the moment of inertia of this body with respect to the x -axis, and let $D = -J_{xz}$ denote the inertia product with respect to the xz axes. Furthermore, let the x and z coordinates of the center of mass be a and h , respectively. The angular momentum of the system with respect to the x axis is [62]

$$L_x = J \frac{d\varphi}{dt} - D\omega = J \frac{d\varphi}{dt} - \frac{VD}{b} \delta.$$

The torques acting on the system are due to gravity and centrifugal forces, and the angular momentum balance becomes

$$J \frac{d^2\varphi}{dt^2} - mgh\varphi = \frac{DV}{b} \frac{d\delta}{dt} + \frac{mV^2h}{b} \delta. \quad (1)$$

The term $mgh\varphi$ is the torque generated by gravity. The terms on the right-hand side of (1) are the torques generated by steering, with the first term due to inertial forces and the second term due to centrifugal forces. The model is called the inverted pendulum model because of the similarity with the linearized equation for the inverted pendulum.

Approximating the moment of inertia as $J \approx mh^2$ and the inertia product as $D \approx mah$, the model becomes

$$\frac{d^2\varphi}{dt^2} - \frac{g}{h}\varphi = \frac{aV}{bh} \frac{d\delta}{dt} + \frac{V^2}{bh} \delta.$$

The model (1), used in [37] and [21], is a linear dynamical system of second order with two real poles

$$p_{1,2} = \pm \sqrt{\frac{mgh}{J}} \approx \pm \sqrt{\frac{g}{h}} \quad (2)$$

and one zero

$$z = -\frac{mVh}{D} \approx -\frac{V}{a}. \quad (3)$$

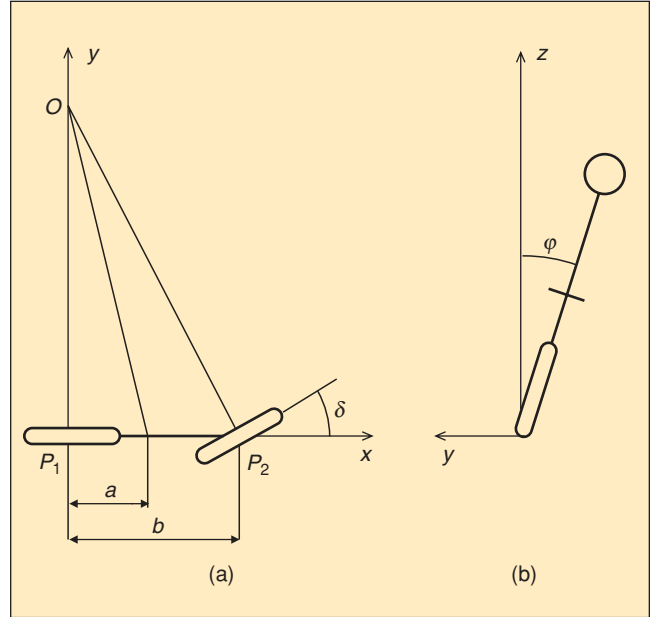

Figure 3. Schematic (a) top and (b) rear views of a naive ($\lambda = 0$) bicycle. The steer angle is δ , and the roll angle is φ .

It follows from (1) that the transfer function from steer angle δ to tilt angle φ is

$$\begin{aligned} G_{\varphi\delta}(s) &= \frac{V(Ds + mVh)}{b(Js^2 - mgh)} \\ &= \frac{VD}{bJ} \frac{s + \frac{mVh}{D}}{s^2 - \frac{mgh}{J}} \approx \frac{aV}{bh} \frac{s + \frac{V}{a}}{s^2 - \frac{g}{h}}. \end{aligned} \quad (4)$$

Notice that both the gain and the zero of this transfer function depend on the velocity V .

The model (4) is unstable and thus cannot explain why it is possible to ride with no hands. The system (4), however, can be stabilized by active control using the proportional feedback law

$$\delta = -k_2 \varphi, \quad (5)$$

which yields the closed-loop system

$$J \frac{d^2\varphi}{dt^2} + \frac{DVk_2}{b} \frac{d\delta}{dt} + \left(\frac{mV^2hk_2}{b} - mgh \right) \varphi = 0. \quad (6)$$

This closed-loop system is asymptotically stable if and only if $k_2 > bg/V^2$, which is the case when V is sufficiently large.

The Front Fork

The design of the front fork has a major impact on bicycle dynamics. The simple model (1) does not capture this effect because of the assumptions of zero trail $c = 0$ and head angle $\lambda = 90^\circ$; see Figure 1. To take the front fork into account, we define the torque applied to the handlebars, rather than the steer angle, as the control variable. The contact forces between the tire and road exert a torque on the front fork assembly when there is a tilt. Under certain conditions, this torque turns the front fork toward the lean. The centrifugal force acting on the bicycle then counteracts the lean and can, under certain circumstances, stabilize the system.

To model the front fork, we first observe that the steer angle also influences the tilt angle. For small angles the front fork roll angle is then

$$\varphi_f = \varphi - \delta \cos \lambda, \quad (7)$$

and the effective front fork angle is

$$\delta_f = \delta \sin \lambda. \quad (8)$$

We model the front fork simply by a static torque balance. Let N_f and F_f be the vertical and horizontal components of the forces acting on the front wheel at the ground contact. Neglecting dynamics and gyroscopic effects, we have $N_f = amg/b$ and

$$F_f = \frac{amV^2}{b^2} \delta_f = \frac{amV^2 \sin \lambda}{b^2} \delta.$$

Letting T be the external torque applied to the handlebars and neglecting the weight of the front fork assembly, the static torque balance of the front fork becomes

$$T - (F_f + N_f \varphi_f) c \sin \lambda = 0.$$

Introducing the expressions for F_f , N_f , δ_f , and φ_f yields

$$T - \frac{acmg \sin \lambda}{b} \varphi - \frac{acm \sin \lambda}{b^2} (V^2 \sin \lambda - bg \cos \lambda) \delta = 0. \quad (9)$$

Notice that the sign of the term proportional to δ is negative if $V > V_{sa}$, where

$$V_{sa} = \sqrt{bg \cot \lambda} \quad (10)$$

is the self-alignment velocity.

The torque balance for the front fork assembly (9) can be written as

$$\delta = k_1(V)T - k_2(V)\varphi, \quad (11)$$

where

$$k_1(V) = \frac{b^2}{(V^2 \sin \lambda - bg \cos \lambda)mac \sin \lambda} \quad (12)$$

and

$$k_2(V) = \frac{bg}{V^2 \sin \lambda - bg \cos \lambda}. \quad (13)$$

When $k_2(V)$ is positive and sufficiently large, it follows from (6) that the feedback generated by the front fork stabilizes the bicycle.

The model (11) can be verified qualitatively by determining the torque applied to the front fork when biking in a straight path. Leaning the body toward the left causes the bicycle frame to tilt to the right, which corresponds to positive φ . A positive (counterclockwise) torque is required to maintain a straight path. The steady-state parameters of the model can be experimentally determined from measurements of the torque and the tilt at different velocities.

Self-Stabilization

The frame model (1) changes because of the geometry of the front fork. The steering angle δ is replaced by the effective steering angle δ_f given by (8). The center of mass of the frame is also shifted when the steering wheel is turned, which gives the torque

$$T_\delta = -\frac{mgac \sin \lambda}{b} \delta.$$

The angular momentum balance for the frame given by (1) then becomes

$$J \frac{d^2 \varphi}{dt^2} - mgh \varphi = \frac{DV \sin \lambda}{b} \frac{d\delta}{dt} + \frac{m(V^2 h - acg) \sin \lambda}{b} \delta. \quad (14)$$

Inserting the expression (11) for steer angle δ into (14) gives

$$\begin{aligned} J \frac{d^2 \varphi}{dt^2} + \frac{DVg}{V^2 \sin \lambda - bg \cos \lambda} \frac{d\varphi}{dt} + \frac{mg^2(bh \cos \lambda - ac \sin \lambda)}{V^2 \sin \lambda - bg \cos \lambda} \varphi \\ = \frac{DVb}{acm(V^2 \sin \lambda - bg \cos \lambda)} \frac{dT}{dt} + \frac{b(V^2 h - acg)}{ac(V^2 \sin \lambda - bg \cos \lambda)} T. \end{aligned} \quad (15)$$

This system is stable if

$$V > V_c = \sqrt{bg \cot \lambda} \quad (16)$$

and

$$bh > actan \lambda. \quad (17)$$

Under these assumptions, the critical velocity V_c is equal to the self-aligning velocity V_{sa} given by (10).

Taking the action of the front fork into account, the bicycle is described by (14) and (11). The front fork model (11) provides a negative feedback from tilt to steering angle, as illustrated in Figure 4, which shows that the bicycle can be regarded as a feedback system. The tilt angle φ influences the steer angle δ as described by the frame model (14), and the front wheel angle δ influences the tilt angle φ as described by the front fork model (11). Notice that there is no self-stabilization if the trail c is zero and if the head angle is 90° . Such a bicycle is called neutral.

The model given by (14) and (11) gives a correct qualitative explanation for self-stabilization. There are, however, severe deficiencies in the model. The stabilizing action of the front fork is delayed when the dynamics of the front fork model is considered, and the critical velocity is then larger than predicted by the static front fork model (16). Gyroscopic effects also have an influence. These effects can be included in more detailed linearized models developed using software for multibody systems.

Manual Control

The significant difference between the cases considered above is due to the change in control input from steer angle to steer torque. A practical consequence, realized by skilled riders, is that the self-stabilizing action of the front fork is best achieved by lightly gripping the handlebars. When teaching children to bike, it is important to remind them that they should not hold the handlebars too stiffly. This nuance is difficult for children with learning difficulties, since fear often induces an involuntary rigidity of the body (see “Adapted Bicycles for Teaching Children with Disabilities”).

The rider controls the bicycle by leaning and by applying a torque to the handlebars. The effects of manual steering torques can be seen from (11). A simple model of rider behavior is to assume that the rider acts as a proportional controller by applying a steer torque proportional to bicycle lean, that is, $T = -k\varphi$. Inserting this relation into (11) yields

$$\delta = -(kk_1(V) + k_2(V))\varphi.$$

The rider thus adds to the value of the parameter $k_2(V)$ in (11) through the term $kk_1(V)$. A more complex model of

rider behavior accounts for the neuromuscular delay of humans. A study of motorcycles in [28] gives a neuromuscular delay of 0.1 s for applying steering torque and 0.3 s for upper body lean.

Gyroscopic Effects

The gyroscopic action of the rotation of the front wheel can be included in the model of the front fork. Replacing (11) by

$$\delta = k_1(V)T - k_2(V)\varphi - k_3(V)\frac{d\varphi}{dt}$$

shows that gyroscopic effects give rise to derivative feedback. The parameter $k_3(V)$ is proportional to the angular momentum of the front wheel, and thus also to the velocity.

Rear-Wheel Steering

Standard bicycles have rear-wheel drive and front-wheel steering. Rear-wheel steering has been suggested for recumbent bicycles, for which front-wheel drive is a natural configuration. There are, however, difficulties with rear-wheel steering, as summarized in [8].

Many people have seen theoretical advantages in the fact that front-drive, rear-steered recumbent bicycles would have simpler transmissions than front-driven recumbents and could have the center of mass nearer the front wheel than the rear. The U.S. Department of Transportation commissioned the construction of a safe motorcycle with this configuration. It turned out to be safe in an unexpected way: No one could ride it.

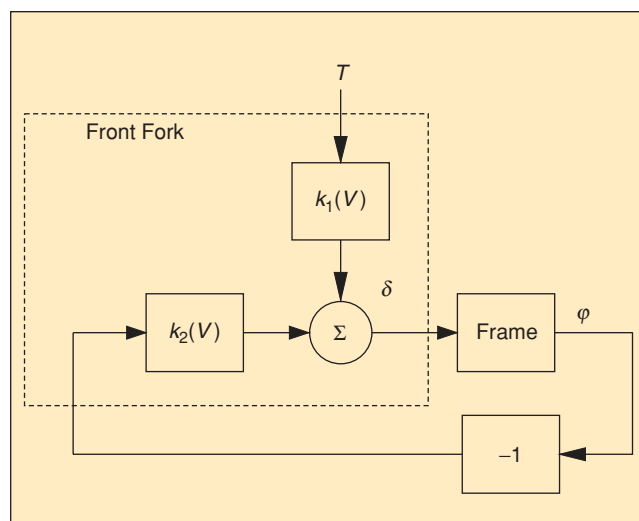
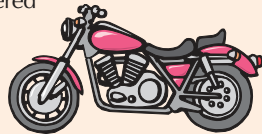

Figure 4. Block diagram of the bicycle with a front fork. The steer torque applied to the handlebars is T , the roll angle is φ , and the steer angle is δ . Notice that the front fork creates a feedback from the roll angle φ to the steer angle δ , which can stabilize the system.

The NHSA Rear-Steered Motorcycle

The U.S. National Highway Safety Administration (NHSA) funded a project aimed at developing a safe motorcycle in the late 1970s. The key ideas included having a low center of mass, a long wheel base, and separation of steering and braking. The last requirement leads naturally to a design with rear-wheel steering, since the front wheel provides the major contribution to the braking force. Rear-wheel steering combined with a long wheel base also makes it possible to have a low center of mass. A contract to analyze a motorcycle with rear-wheel steering and to build a test vehicle was given to South Coast Technology in Santa Barbara, California, with Robert Schwarz as principal investigator.

A theoretical study was performed by taking the mathematical model developed by Sharp [50] and simply reversing the sign of the wheel-angular velocity. A derivation based on first principles showed that reversing the sign does indeed give the correct model. The model was linearized, and the eigenvalues were investigated. Two complex pole pairs and a real pole representing weave, wobble, and capsize dominate the dynamics. A range of geometrical configurations was investigated. The eigenvalues were plotted as functions of velocity for each configuration. The real part of the unstable poles typically covered 4–12 rad/s for speeds of 3–50 m/s. It was concluded that the instability was too fast to be stabilized by a human rider.



The result was reported to NHSA with a recommendation that it was pointless to build a prototype because the motorcycle could apparently not be ridden. NHSA was of a different opinion based on an in-house study, and they insisted that a prototype should be built and tested. The tests showed conclusively that the motorcycle was unrideable, even by the most skilled riders.

The outriggers were essential; in fact, the only way to keep the machine upright for any measurable period of time was to start out down on one outrigger, apply a steer input to generate enough yaw velocity to pick up the outrigger, and then attempt to catch it as the machine approached vertical. Analysis of film data indicated that the longest stretch on two wheels was about 2.5 s. [77]

The story behind this quote, which is elaborated in “The NHSA Rear-Steered Motorcycle,” illustrates that it is possible to design systems that have many desirable static properties but are practically useless because of their dynamics.

A model for a bicycle with rear-wheel steering is obtained simply by reversing the sign of the velocity of models with forward-wheel steering. Consider, for example, the model of a bicycle with zero trail ($c = 0$) and head angle $\lambda = 90^\circ$ whose transfer function from steer angle to tilt is given by (4). Reversing the sign of the velocity gives the transfer function

$$\begin{aligned} G_{\phi\delta}(s) &= \frac{-VDs + mV^2h}{b(Js^2 - mgh)} \\ &= \frac{VD}{bJ} \frac{-s + \frac{mVh}{D}}{s^2 - \frac{mgh}{J}} \approx \frac{aV}{bh} \cdot \frac{-s + V/a}{s^2 - g/h}, \end{aligned} \quad (18)$$

which has one pole and one zero in the right-half plane. Such a system is difficult to control robustly when the pole and zero are too close [63], [64].

Attempting to stabilize the system with the transfer function (18) using the proportional feedback (5), we find that the closed-loop system is

$$J \frac{d^2\phi}{dt^2} - \frac{DVk_2}{b} \frac{d\delta}{dt} + \left(\frac{mV^2hk_2}{b} - mgh \right) \phi = 0. \quad (19)$$

The closed-loop system is unstable for all positive velocities and values of the feedback gain k . Furthermore, difficulties remain even if an arbitrarily complex control law is used, since there are fundamental problems in controlling a system with poles and zeros in the right-half plane. Specifically, robust control of such systems requires that the ratio between the right-half-plane zero z and the right-half-plane pole p be large [63], [64]. For the system (18) we have

$$\frac{z}{p} = \frac{mVh}{D} \sqrt{\frac{J}{mgh}} \approx \frac{V}{a} \sqrt{\frac{h}{g}}.$$

As the velocity increases, this ratio also increases, which improves the robustness of the closed-loop system.

The zeros of a system depend on the interconnections between sensors, actuators, and states. Zeros change when sensors are changed, and all zeros disappear when all state variables are measured. Problems caused by right-half-plane zeros can thus be eliminated by introducing more sensors. For the rear-steered bicycle, the prob-

lem caused by the right-half-plane zero can be eliminated by introducing tilt and yaw rate sensors. As discussed in “Alleviating Problems with Zeros in the Right-Half Plane,” the problem cannot be alleviated by using an observer.

Maneuvering

Having obtained some insight into the stabilization problem, we now turn to the problem of maneuvering. A central problem is to determine how the torque on the handlebars influences the path of the bicycle. The first step is to investigate how the steer torque T influences the steer angle δ . For the bicycle model (1) with the stabilizing front fork modeled by (11), the transfer function from steer torque to steer angle is given by

$$G_{\delta T}(s) = \frac{k_1(V)}{1 + k_2(V)G_{\phi\delta}(s)},$$

where $G_{\phi\delta}(s)$ is given by (4); see Figure 4. Hence

$$G_{\delta T}(s) = \frac{k_1(V) \left(s^2 - \frac{mgh}{J} \right)}{s^2 + \frac{k_2(V)DV}{bJ}s + \frac{k_2(V)V^2mh}{bJ} - \frac{mgh}{J}}, \quad (20)$$

which shows that the poles of the transfer function $G_{\phi\delta}$ appear as zeros of the transfer function $G_{\delta T}$.

To determine how the bicycle’s path is influenced by the steer angle, we use the coordinate system in Figure 2. Assuming that the angle ψ is small and linearizing around a straight line path along the ξ axis yields

$$\begin{aligned} \frac{d\eta}{dt} &= V\psi, \\ \frac{d\psi}{dt} &= \frac{V}{b}\delta. \end{aligned}$$

The transfer function from steer angle δ to path deviation η is thus

$$G_{\eta\delta}(s) = \frac{V^2}{bs^2}.$$

Combining $G_{\eta\delta}(s)$ with (20) gives the transfer function from steer torque T to η , which has the form

$$G_{\eta T}(s) = \frac{k_1(V)V^2}{b} \frac{s^2 - \frac{mgh}{J}}{s^2 \left(s^2 + \frac{k_2(V)VD}{bJ}s + \frac{mgh}{J} \left(\frac{V^2}{V_c^2} - 1 \right) \right)}. \quad (21)$$

Alleviating Problems with Zeros in the Right-Half Plane

The problem with right half-plane zeros can be eliminated by introducing extra sensors and actuators. Consider the standard linear system

$$\begin{aligned} \frac{dx}{dt} &= Ax + Bu, \\ y &= Cx, \end{aligned}$$

where $x \in \mathbb{R}^n$, $u \in \mathbb{R}^p$, and $y \in \mathbb{R}^q$. The invariant zeros of the system are the values of s for which the matrix

$$\begin{pmatrix} sI - A & B \\ C & 0 \end{pmatrix}$$

loses rank. A system has no invariant zeros if either B or C has rank n .

The difficulties with the rear-steered bicycle can thus be eliminated by introducing a feedback system with a rate gyro and a tilt sensor. However, the system then becomes critically dependent on sensing and actuation, which implies that control is mission critical [78].

It also follows that a system has no zeros if the matrix B has rank n . Hence, the problem caused by right half-plane zeros can alternatively be eliminated by using additional actuators. Maneuvering of bicycles is a typical example. By using both steer torque and rider lean, the zero in the transfer function (21) can be eliminated. In fact, skilled riders frequently use variations in forward speed as an additional control variable, since centrifugal forces can be altered to some extent.

When the tilt dynamics of the bicycle is stabilized by the front fork, the maneuvering dynamics have a zero in the right-half plane at $s = \sqrt{mgh/J}$, which imposes limitations on the maneuverability.

Figure 5 shows the path of a bicycle when a positive torque-step input is applied to the handlebars. Notice that the path deviation η is initially positive but later becomes negative. This inverse response behavior, which is typical for a system with a right-half-plane zero, can be explained as follows. When a positive steer torque is applied, the bicycle’s contact points with the ground initially track in the direction of the applied torque. This motion generates a reaction force that tilts the bicycle around the positive x axis. In turn, this tilt generates a

Wilbur Wright on Counter-Steering

Wilbur Wright owned a bicycle shop with his brother Orville. Wilbur had an amazing ability to intuitively understand complex, technical problems, as illustrated by the following:

I have asked dozens of bicycle riders how they turn to the left. I have never found a single person who stated all the facts correctly when first asked. They almost invariably said that to turn to the left, they turned the handlebar to the left and as a result made a turn to the left. But on further questioning them, some would agree that they first turned the handlebar a little to the right, and then as the machine inclined to the left they turned the handlebar to the left, and as a result made the circle inclining inwardly. [79, p. 170]

Wilbur's understanding of dynamics contributed strongly to the Wright brothers' success in making the first airplane flight.

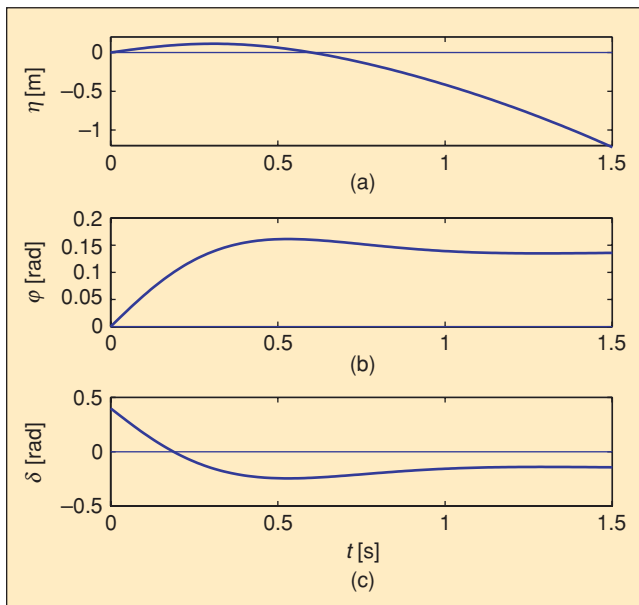
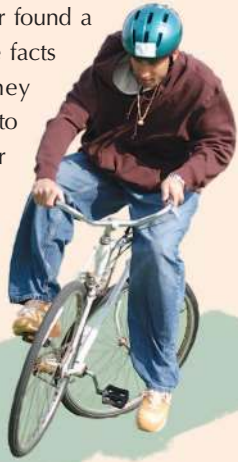

Figure 5. Simulation of the bicycle with a constant positive steer torque. The plots show the time histories of (a) the path deviation η , (b) the tilt angle ϕ , and (c) the steer angle δ . Notice the reverse response in the path η .

torque on the front fork, due in large part to the upward action of the ground supporting the front wheel, which rotates the front fork in the negative direction. Thus, both the lean angle and the steer angle tend to be, as the bicycle's transient decays, in the direction opposite to the torque applied to the handlebars. Recall again that the roll angle ϕ of the rear frame is positive when leaning to the right. In Figure 5, the lean angle settles to $\phi = 0.14$ rad, whereas the steer angle settles to $\delta = -0.14$ rad. Given the curves in Figure 5, it is straightforward to give a physical explanation, although it is difficult to apply causal reasoning directly because of the closed-loop nature of the system. The physical argument also indicates a remedy because the centrifugal force can be opposed by gravitational forces if the biker leans his or her upper body relative to the frame. This motion is precisely what experienced riders do automatically.

The inverse nature of the response to steer torque has contributed to a number of motorcycle accidents. To explain this phenomenon, visualize a motorcycle driven along a straight path and assume that a car suddenly appears from the right. The intuitive reaction is to try to steer left, away from the car. The motorcycle initially does so when the steer torque is applied to the left, but, because of the nature of the maneuvering dynamics, the motorcycle ultimately steers into the car as indicated in Figure 5. A significant number of motorcycle accidents are caused by novice riders who fail to counter-steer. The remedy is to simultaneously lean and counter-steer, which consists of applying a torque to the handlebars in the opposite direction of the intended travel. Counter-steering establishes a lean, which aids in turning the motorcycle away from the obstacle that has appeared in front of the rider. Leaning without counter-steering suffices in many normal traveling conditions, such as routine lane changes. Counter-steering is necessary for fast lane changes since the dynamics of leaning alone have a long response time. It is interesting that Wilbur Wright was fully aware of these advantages, as illustrated in "Wilbur Wright on Counter-Steering."

Effects of Rider Lean

In terms of model development, it has been assumed that the rider sits rigidly on the bicycle without leaning. A simple way to describe the effect of leaning is to consider the rider as composed of two rigid pieces, the lower body and the upper body, where the upper body can be rotated as illustrated in Figure 6.

Let ϕ denote the upper body lean angle relative to a plane through the bicycle. The linearized momentum balance given by (1) is then replaced by

$$J \frac{d^2 \phi}{dt^2} + J_r \frac{d^2 \phi}{dt^2} = mgh\phi + m_r g h_r \phi + \frac{DV}{b} \frac{d\delta}{dt} + \frac{mV^2 h}{b} \delta, \quad (22)$$

where J_r is the moment of inertia of the upper body with respect to the x axis, m_r is the mass of the upper body, and h_r is the distance from the center of mass of the upper body to its turning axis. Combining (22) with the static model of the front fork (11) gives a model of the bicycle with a leaning rider, which has the form

$$\begin{aligned} J \frac{d^2 \varphi}{dt^2} + \frac{DVk_2(V)}{b} \frac{d\varphi}{dt} + \left(\frac{mV^2hk_2(V)}{b} - mgh \right) \varphi \\ = \frac{DVk_1(V)}{b} \frac{dT}{dt} + \frac{mV^2k_1(V)}{b} T - J_r \frac{d^2 \phi}{dt^2} + m_r g h_r \phi. \end{aligned} \quad (23)$$

The dynamics relating steer angle to steer torque and lean is a second-order dynamic system. The difficulties associated with the right-half-plane zero in (20) can be avoided because the system has two inputs; namely, steering and leaning. By proper coordination of handlebar torque and upper body lean, it is possible to alleviate problems occurring when using only handlebar torque for steering. This technique is what we normally do intuitively when biking. The system theoretic interpretation is that the right-half-plane zero is eliminated by introducing an additional control variable (see “Alleviate Problems with Zeros in the Right-Half Plane”).

More Complicated Models

The simple models used so far shed insight but are not detailed enough to give accurate answers to some interesting questions, such as how the critical velocity depends on the geometry and mass distribution of the bicycle. There are physical phenomena that warrant investigation in greater depth, such as gyroscopic effects and tire-road interaction. A nonlinear model can be used to analyze straight line forward motion as well as continuously turning maneuvers.

Most bicycle models are linear because they were developed before adequate computer tools were available. Today it is feasible to develop complex multibody models using general object-oriented software such as Modelica [65]. A mechanical system can be viewed as an interconnection of subsystems, which are described in an object oriented manner. Equations for each subsystem are given as balances of mass, momentum, and energy, together with constitutive equations. Component libraries can be built, and modeling is performed conveniently by dragging and dropping graphical objects.

A Modelica library for multibody systems, described in [45], gathers all equations for subsystems and interconnections and uses symbolic computations to eliminate redundant equations. The resulting equations are

The bicycle’s evolution has been a product of necessity, ingenuity, materials, and industrialization.

then transformed into ordinary differential equations or differential-algebraic equations, which are then integrated numerically. Linearized equations are obtained as a side product. Special purpose software for multibody systems [40]–[44] can also be used. The nonlinear model analyzed in the following is derived with a multibody software described in [46] and [66]. A similar approach is used in [47].

A Linear Fourth-Order Model

A simple second-order model of the bicycle consists of a dynamic torque balance for the frame (1) and a static momentum balance for the front fork assembly (11). A natural extension is to replace the static front fork model with a dynamic model, which yields the fourth-order model

$$M \begin{pmatrix} \ddot{\varphi} \\ \ddot{\delta} \end{pmatrix} + CV \begin{pmatrix} \dot{\varphi} \\ \dot{\delta} \end{pmatrix} + (K_0 + K_2 V^2) \begin{pmatrix} \varphi \\ \delta \end{pmatrix} = \begin{pmatrix} 0 \\ T \end{pmatrix}, \quad (24)$$

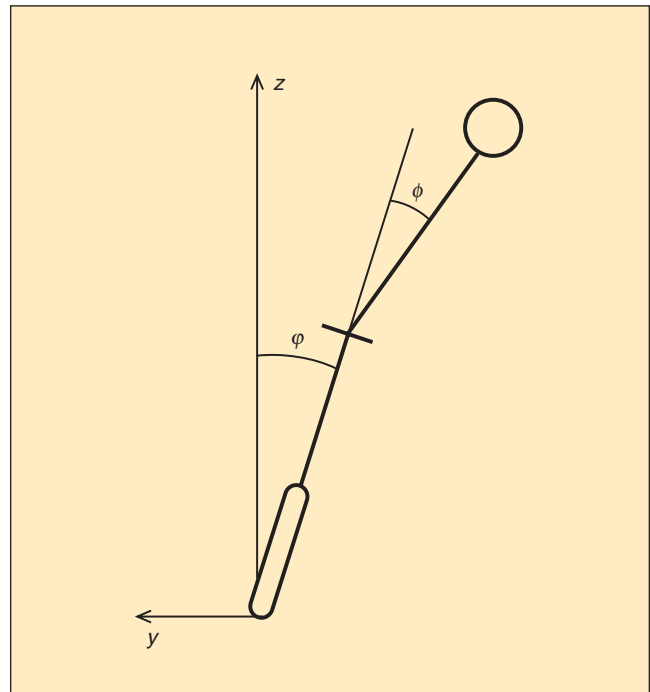

Figure 6. Rear view of the bicycle with a leaning rider. The bicycle roll angle is φ , while the rider lean relative to the bicycle is ϕ .

where V denotes the forward speed, and the elements of the matrices depend on the geometry and mass distribution of the bicycle. The model was derived by Whipple [4] in 1899 and elaborated in [24], [25], [27], and [67]. The model is compared with numerical linearization of nonlinear models obtained from two multibody programs in [48], where the bicycle is described by 23 parameters; namely, wheel base $b = 1.00$ m, trail $c = 0.08$ m, head angle $\lambda = 70^\circ$, wheel radii $R_{rw} = R_{fw} = 0.35$ m, and parameters that characterize the mass distribution. The parameters listed in Table 1, with $g = 9.81$ m/s², yield the following numerical values

$$\begin{aligned} M &= \begin{pmatrix} 96.8 (6.00) & -3.57(-0.472) \\ -3.57 (-0.472) & 0.258 (0.152) \end{pmatrix}, \\ C &= \begin{pmatrix} 0 & -50.8 (-5.84) \\ 0.436 (0.436) & 2.20 (0.666) \end{pmatrix}, \\ K_0 &= \begin{pmatrix} -901.0 (-91.72) & 35.17 (7.51) \\ 35.17 (7.51) & -12.03 (-2.57) \end{pmatrix}, \\ K_2 &= \begin{pmatrix} 0 & -87.06 (-9.54) \\ 0 & 3.50 (0.848) \end{pmatrix}. \end{aligned} \quad (25)$$

The values in parentheses are for a bicycle without a rider. This model is well suited for the design of autopilots for bicycles.

The momentum balance for the roll axis is similar to the simple model (1), but there is an additional inertia term $m_{12}d^2\delta/dt^2$ due to the shift of the mass when the front fork is turned. The model (24) gives the self-alignment velocity of the front fork as $V_{sa} = \sqrt{7.51/2.57} = 1.74$ m/s, which can be compared with the value 1.89 m/s given by (10).

	Rear Frame	Front Frame	Rear Wheel	Front Wheel
Mass m [kg]	87 (12)	2	1.5	1.5
Center of Mass				
x [m]	0.492 (0.439)	0.866	0	b
z [m]	1.028 (0.579)	0.676	R_{rw}	R_{fw}
Inertia Tensor				
J_{xx} [kg-m ²]	3.28 (0.476)	0.08	0.07	0.07
J_{xz} [kg-m ²]	-0.603 (-0.274)	0.02	0	0
J_{yy} [kg-m ²]	3.880 (1.033)	0.07	0.14	0.14
J_{zz} [kg-m ²]	0.566 (0.527)	0.02	J_{xx}	J_{xx}

A Fourth-Order Nonlinear Model

For more detailed investigations of bicycle dynamics, we use the nonlinear model in [46], which was generalized so that bicycles with toroidal wheels could be analyzed. The model was developed using Sophia [66], which is a package of Maple procedures for symbolic representation of multibody dynamics. The dynamical equations have the form

$$\begin{aligned} \mathcal{M}(\varphi, \delta) (\dot{u}_\varphi \dot{u}_\delta \dot{\omega})^T &= \mathcal{F}(\varphi, \delta, u_\varphi, u_\delta, \omega, T), \\ (\dot{\varphi} \dot{\delta})^T &= (u_\varphi u_\delta)^T, \end{aligned} \quad (26)$$

where \mathcal{M} is a 3×3 symmetric matrix, u_φ is the roll angle velocity, u_δ is the steer angle velocity, and ω is the angular velocity of the front wheel projected onto its axis. The term \mathcal{F} is a vector of generalized forces, which are functions of the state and externally applied forces and torques. In our case, only gravitation is considered. The equations are much too long to publish in text form, since all components are complicated functions of variables and parameters defining the geometry and the mass distribution. Because of the nonholonomic rolling constraints, the number of coordinates differs from the number of generalized velocities in a minimal description. The dynamical system has dimension five, but energy is preserved if the applied forces are conservative, and the dynamics are of fourth order. Linearization of (26) by symbolic methods gives the linear model (24).

The bifurcation diagram in Figure 7 yields fixed points of a bicycle with a rider rigidly attached to the rear frame and illustrates the complex behavior of the nonlinear model. These fixed points are characterized by $u_\varphi = u_\delta = 0$, $\mathcal{F} = 0$, and $\omega \neq 0$. Apart from the zero solution $\varphi = 0$ and $\delta = 0$, there are continuously turning solutions and several saddle-node bifurcations. All of these turning solutions are unstable.

Although the fourth-order model captures many aspects of the bicycle, there are effects that are neglected. Several extensions of the model are of interest. Frame elasticity is noticeable in conventional bicycles with diamond-shaped frames and even more so in frames for women, not to mention mountain bikes with front and rear suspension springs. The elasticity of pneumatic tires can also be considered, as in [25] and [50]. Furthermore, the effects of the interaction between the tires and the road can be considered. Finally, it is interesting to have a more realistic model of the rider.

Stability of an Uncontrolled Bicycle

The simple second-order model (11), (14) indicates that a bicycle is self-stabilizing provided that the velocity is sufficiently large. Self-stabilization will now be explored using the fourth-order linear model (24). Figure 8 shows the root locus of the model (24) with matrices given by (25) for the bicycle with a rider. When the velocity is zero, the system has four real poles at $p_{1,2} = \pm 3.05$ and $p_{3,4} = \pm 9.18$, marked with circles in Figure 8. The first pair of poles corresponds to the pendulum poles, given by (2). The other pole pair corresponds to the front fork dynamics. As the velocity increases, the poles p_2 and p_4 meet at a velocity that is close to the self-alignment velocity and combine to a complex pole pair. The real part of the complex pole-pair decreases as the velocity increases. Following [50] this mode is called the weave mode. The weave mode becomes stable at the critical velocity $V_c = 5.96$ m/s. The pendulum pole p_1 remains real and moves toward the right with increasing velocity. It becomes unstable at the velocity $V = 10.36$ m/s, where the determinant of the matrix $K_0 + V^2 K_2$ vanishes. This mode has little

influence on practical rideability, since it can easily be stabilized by manual feedback. The pole p_3 moves to the left as velocity increases. For large V , it follows from (24) that one pole approaches zero, and three poles are asymptotically proportional to the velocity, specifically, $p = (-0.65 \pm 1.33i)V$, and $-1.40V$.

The bicycle can be used to illustrate a wide variety of control concepts such as modeling, nonlinear dynamics, and codesign of process and control.

The velocity range for which the bicycle is stable is more clearly visible in Figure 9, which shows the real part of the poles as functions of velocity. The values for negative velocities correspond to a rear-steered bicycle. Figure 9 shows that the poles for a rear-steered bicycle have positive real parts for all velocities.

The nonlinear model reveals even more complex behavior. There is a stable limit cycle for velocities

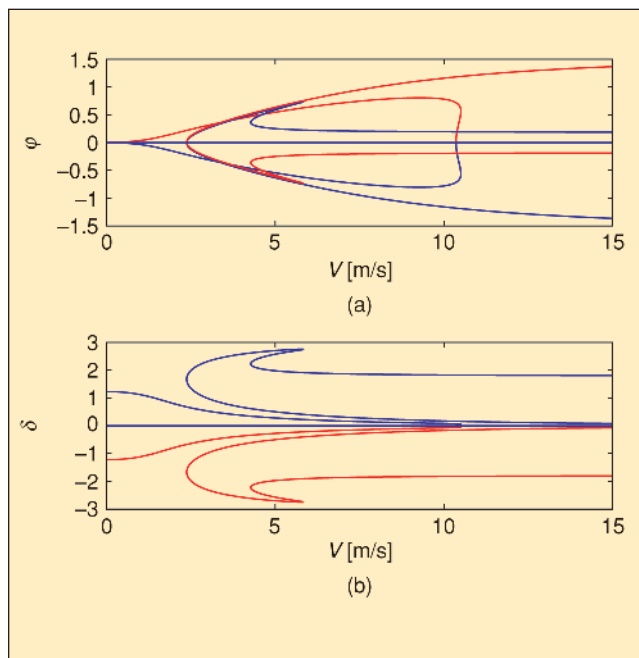

Figure 7. Bifurcation diagram for a nonlinear model of the bicycle with a rider. The upper curve shows equilibria of the tilt angle φ as a function of velocity V , while the lower curves show corresponding equilibria of the steering angle δ . Notice that there are many equilibria. The equilibrium $\varphi = 0$, $\delta = 0$ is stable for $5.96 \text{ m/s} \leq V \leq 10.36 \text{ m/s}$.

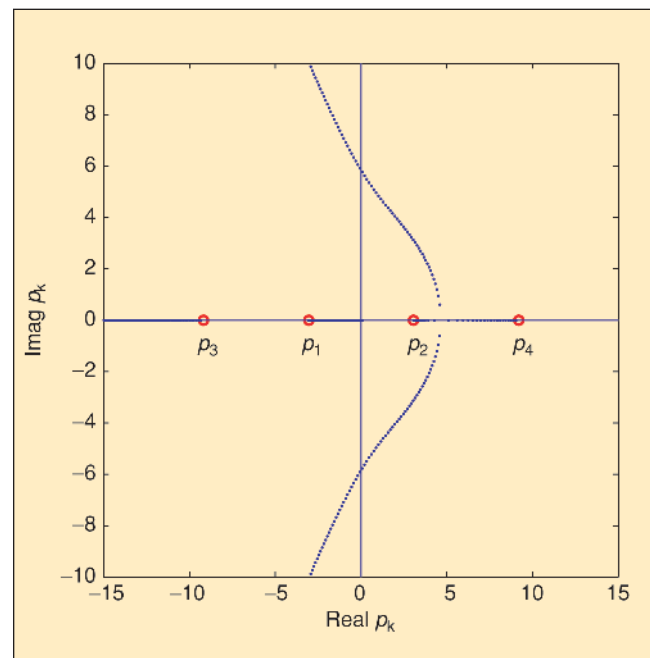

Figure 8. Root locus for the bicycle with respect to velocity. The model is given by (24) with parameters given by (25). The poles at zero velocity, marked with red o, are symmetric with respect to the imaginary axis. The poles p_1 and p_2 are the pendulum poles given by (2), and the poles p_3 and p_4 are the front fork poles.

below the critical velocity, as illustrated in Figure 10, which shows trajectories for a bicycle without a rider for initial velocities above and below the critical velocity. The stable periodic orbit is clearly visible in the figure. There is period doubling when the velocity is reduced

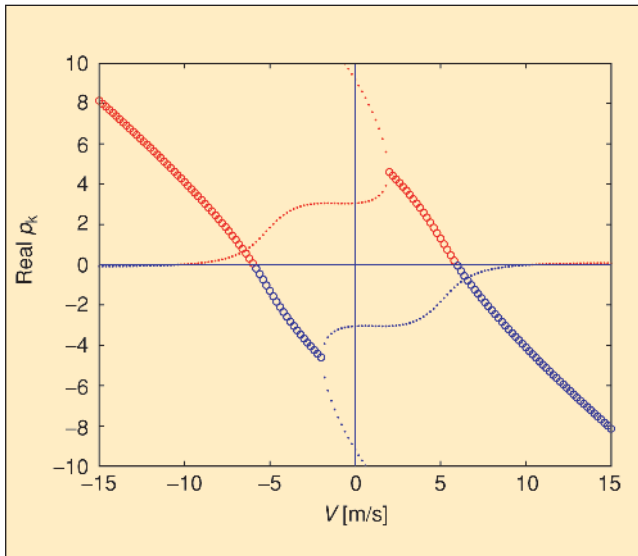

Figure 9. Real parts of the poles for a bicycle with a rider as a function of velocity. Real poles are indicated by a dot, complex poles by o, unstable poles are red, and stable poles are blue. The figure shows that the bicycle is self-stabilizing for $5.96 \text{ m/s} \leq V \leq 10.36 \text{ m/s}$.

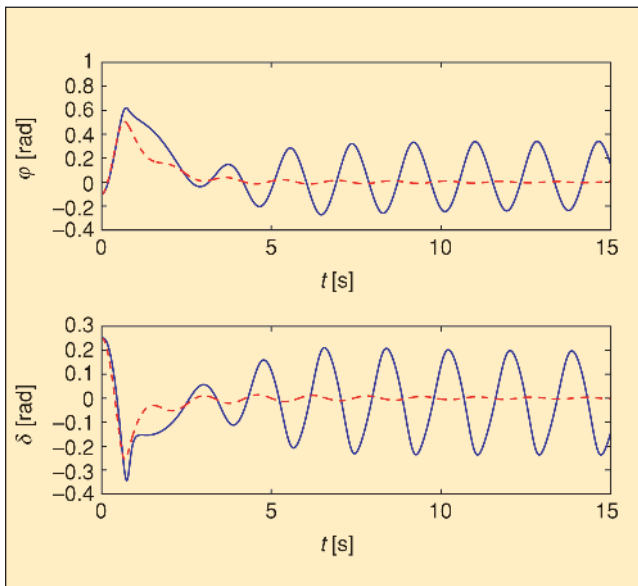

Figure 10. Simulation of the nonlinear model (26) of a bicycle with a rigid rider. The solid lines correspond to initial conditions below the critical velocity, while the dashed lines correspond to initial conditions slightly above the critical velocity. The figure shows that there is a stable limit cycle for certain velocities.

further. The periodic orbit can be observed in carefully executed experiments.

Gyroscopic Effects

A frequent question is to what extent gyroscopic effects contribute to stabilization of bicycles [69]. This question was raised by Klein and Sommerfeld [10]. Sommerfeld summarizes the situation as follows:

That the gyroscopic effects of the wheels are very small compared with these (centrifugal effects) can be seen from the construction of the wheel; if one wanted to strengthen the gyroscopic effects, one should provide the wheels with heavy rims and tires instead of making them as light as possible. It can nevertheless be shown that these weak effects contribute their share to the stability of the system. [68]

Jones [13] experimentally determined that gyroscopic action plays a relatively minor role in the riding of a bicycle at normal speeds. Jones wanted to design an unridable bicycle, and he investigated the effects of gyroscopic action experimentally by mounting a second wheel on the front fork to cancel or augment the angular momentum of the front wheel.

This creation, “Unridable Bicycle MK1,” unaccountably failed; it could easily be ridden, both with the extra wheel spinning at high speed in either direction and with it stationary. Its “feel” was a bit strange, a fact I attribute to the increased moment of inertia about the front forks, but it did not tax my (average) riding skill even at low speed. [13]

Klein and students at the University of Illinois at Urbana-Champaign (UIUC) conducted a number of precession canceling and altering experiments in the 1980s based on two experimental bicycles that are similar except for the front fork geometries. The bicycle in Figure 11 has an unaltered steering head and a positive trail. Similar to Jones’ results, this precession-canceling bicycle is easily rideable. The bicycle in Figure 12 has an altered



Figure 11. A UIUC bicycle with precession canceling. This bicycle is used to illustrate that gyroscopic effects have little influence on rideability.

LOUIS MCCLELLAN/TOMPSON-MCCLELLAN PHOTOGRAPHY

frame, thereby accommodating a vertical steering head and front fork, as well as zero trail. This bicycle, called the *naïve bicycle*, has no predisposition for the handlebars to turn when the bicycle leans. While the naïve bicycle is modestly wobbly when ridden, it is indeed rideable.

The effects of precession, which are more pronounced for riderless bicycles, can be explored by calculating the closed-loop poles for different moments of inertia of the wheels. The moments of inertia are varied from 0 to 0.184 kg m^2 , corresponding to the case in which all of the mass is located at the perimeter of the wheel. The results are given in Figure 13, showing that the velocity interval for which the bicycle is stable is shifted toward lower velocities when the front wheel inertia is increased. This effect is validated by experiments using bicycles of the type shown in Figure 14. Notice in the figure that the velocity at which the capsizing mode becomes unstable is inversely proportional to the square of the moments of inertia of the wheels. This dependence suggests that there is a simple formula for the velocity limit, which remains to be found. For asymptotically low moments of inertia, it appears that the ratio of the velocities is constant.

The difficulties in manually controlling unstable systems can be expressed in terms of the dimensionless quantity $p\tau$, where p is the unstable pole and τ is the neural delay of the human controller expressed in seconds. A system with $p\tau > 2$ cannot be stabilized at all. In [64], it is shown that comfortable stabilization requires that $p\tau < 0.2$. A crude estimate of the neural delay for bicycle steering is $\tau = 0.2 \text{ s}$ [28]. A bicycle can thus be ridden comfortably so long as the unstable pole has a real part that is less than 1 rad/s .

Wheels

Many bicycles have thin tires whose tube diameter is an order of magnitude smaller than the wheel radius. The crowned rollers used in bicycles for children with disabilities change the dynamics significantly (see “Adapted Bicycles for Teaching Children with Disabilities”). This effect is illustrated in Figure 15, which shows the poles for an adapted bicycle with a rider. The bicycle has a rear wheel with a crowned roller having a lateral radius of 0.4 m and the height of the center of the mass is 0.4 m . The weave mode becomes stable at 3.9 m/s , and the capsizing mode remains stable for all velocities. The dynamics of the system are also slower as predicted by (27) in “Adapted Bicycles for Teaching Children with Disabilities.”

Bicycles in Education

Bicycles are simple, inexpensive, and highly attractive for use in education. In addition, most students ride bicycles and have some feel for their behavior. The bicycle can be used to illustrate a wide variety of control



LOUIS MCCLELLAN/THOMPSON-MCCLELLAN PHOTOGRAPHY

Figure 12. The UIUC naïve bicycle with precession canceling. This bicycle is used to demonstrate that a bicycle is rideable even when there are no gyroscopic effects. The bicycle is similar to the bicycle in Figure 11 but has a vertical front fork ($\lambda = 90^\circ$) and zero trail ($c = 0$, see Figure 1), which means that the front fork does not turn when the bicycle is tilted.

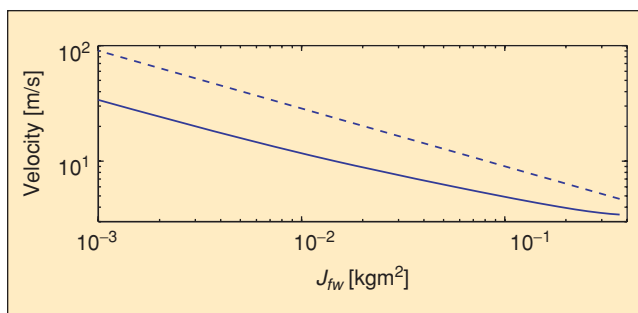

Figure 13. Critical velocities as functions of the moment of inertia of the front wheel. The solid line shows the velocity at which the bicycle becomes stable, while the dashed line shows the velocity at which the capsizing mode becomes unstable. The figure shows that the gyroscopic effect of the front wheel modifies the parameters but not the qualitative behavior of the bicycle. Notice that the scales are logarithmic.



ROLF BRAUN

Figure 14. The Lund University bicycle. This bicycle has a weighted front wheel to exaggerate gyroscopic effects and an elastic cord attached to a neck on the front fork to enhance self-stabilization.

concepts such as modeling, dynamics of nonlinear non-holonomic systems, stabilization, fundamental limitations, the role of right-half-plane poles and zeros, the role of sensing and actuation, control design, adaptation, and codesign of process and control. The bicycle is also well suited to activities for K–12 education and for the general public. Self-stabilization of conventional bicycles and the counterintuitive properties of rear-steered bicycles are useful in this context. A few experiments will be presented in this section.

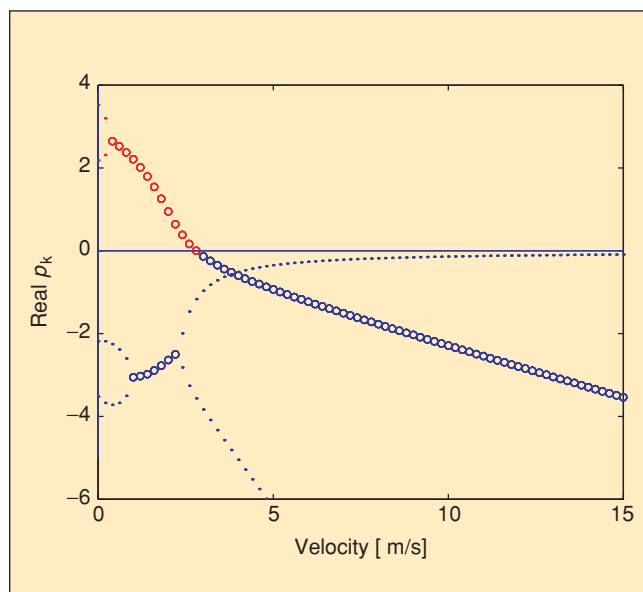

Figure 15. Real parts of the poles for an adapted bicycle with a rider. The bicycle has a crowned roller (see Figure 21) with lateral radius 0.3 m at the rear and a heavy front wheel. A comparison with Figure 9 shows that the behavior is qualitatively the same as for an ordinary bicycle but that the real parts of the poles are numerically smaller, thus making the adapted bicycle easier to ride.



Figure 16. The handlebar of the instrumented UCSB bicycle. Steer torque is measured using a strain gauge on the right. The box on the left contains a display for speed and switches for data logging.

Pioneering work on the use of the bicycle in education was done at Cornell University [67] and at the UIUC [70]–[72]. An adaptive controller for a bicycle was designed at the Department of Theoretical Cybernetics at the St. Petersburg State University [57]. Several universities have incorporated bicycles into the teaching of dynamics and controls, for example, Lund University, the University of California Santa Barbara (UCSB), and the University of Michigan.

Instrumentation

There are many simple experiments that can be conducted with only modest instrumentation. A basic on-board instrumentation system can provide measurements of wheel speed, lean angle, relative lean angle of the rider, front fork steer angle, and steer torque. Gyros and accelerometers give additional information, as do video cameras on the ground, on the frame, and on the handlebars. Examples of on-board instrumentation are given in Figures 16 and 17.



Figure 17. Rear part of the instrumented UCSB bicycle. A potentiometer is used to sense rider lean. The boxes contain a data logger and a power pack.



Figure 18. Klein's original unridable rear-steered bicycle. This bicycle shows the difficulties of controlling a system with poles and zeros in the right-half plane. There is a US\$1,000 prize for riding this bicycle under specified conditions.

Control Is Important for Design

Engineering systems are traditionally designed based on static reasoning, which does not account for stability and controllability. An advantage of studying control is that the fundamental limitations on design options caused by dynamics can be detected at an early stage. Here is a scenario that has been used successfully in many introductory courses.

Start a lecture by discussing the design of a recumbent bicycle. Lead the discussion into a configuration that has a front-wheel drive and rear-wheel steering. Have students elaborate the design, then take a break and say, “I have a device with this configuration. Let’s go outside and try it.” Bring the students to the yard for experiments with the rear-steered bicycle, and observe their reactions. The riding challenge invariably brings forth willing and overly courageous test riders who are destined to fail in spite of repeated attempts. After a sufficient number of failed attempts, bring the students back into the classroom for a discussion. Emphasize that the design was beautiful from a static point of view but useless because of dynamics. Start a discussion

about what knowledge is required to avoid this trap, emphasizing the role of dynamics and control. You can spice up the presentation with the true story about the NHSA rear-steered motorcycle. You can also briefly mention that poles and zeros in the right-half plane are crucial concepts for understanding dynamics limitations. Return to a discussion of the rear-steered bicycle later in the course when more material has been presented. Tell students how important it is to recognize systems that are difficult to control because of inherently bad dynamics. Make sure that everyone knows that the presence of poles and zeros in the right-half plane indicates that there are severe difficulties in controlling a system and also that the poles and zeros are influenced by sensors and actuators.

This approach, which has been used by one of the authors in introductory classes on control, shows that a basic knowledge of control is essential for all engineers. The approach also illustrates the advantage of formulating a simple dynamic model at an early stage in a design project to uncover potential problems caused by unsuitable system dynamics.

The Front Fork

The front fork is essential for the behavior of the bicycle, particularly the self-stabilization property. A simple experiment is to hold the bicycle gently in the saddle and lean the bicycle. For a bicycle with a positive trail, the front fork will then flip towards the lean. Repeating the experiment while walking at different speeds shows that the front fork

aligns with the frame when the speed is sufficiently large. Another experiment is to ride a bicycle in a straight path on a flat surface, lean gently to one side, and apply the steer torque to maintain a straight-line path. The torque required can be sensed by holding the handlebars with a light fingered grip. Torque and lean can also be measured with simple devices as discussed below. The functions



Figure 19. Klein’s rideable rear-steered bicycle. This bicycle is rideable because the rider has a high center of gravity and because the vertical projection of the center of mass of the rider is close to the contact point of the driving wheel with the ground.



Figure 20. The UCSB rear-steered bicycle. This bicycle is rideable as demonstrated by Dave Bothman, who supervised the construction of the bicycle. Riding this bicycle requires skill and dare because the rider has to reach high speed quickly.

$k_1(V)$ and $k_2(V)$ in (11) can be determined by repeating the experiment at different speeds.

Most students are astonished to realize that in many no-hands riding conditions, one initiates a turn by leaning into the turn, but the matter of maintaining the steady-state turn requires a reverse lean, that is, leaning opposite to

the direction of turn. This realization is a good illustration of the bicycle's counterintuitive nature associated with its nonminimum phase properties.

Quantitative data can be obtained by measuring four variables, namely, steer torque, rider lean angle relative to the frame, steer angle, and forward velocity. In the

Adapted Bicycles for Teaching Children with Disabilities

While it is an intellectual challenge to design unridable bicycles, it is more useful to design bicycles that are easy to ride. Klein and colleagues have developed a program and a methodology to permit children to ride bicycles more easily [60], [61]. This program, which has been successful in teaching children with disabilities to ride bicycles, is based on knowledge of bicycle dynamics, rider perceptions, and limitations. Children who are fearful of riding, or children who have yet to learn to ride, typically fear speed and thus timidly pedal in anticipation of falling. The low speed, compounded by rigidity of the child's tense body and previous exposure to training wheels tend to make the experience uncomfortable and erratic for the child. In particular, the children cannot benefit from the self-stabilizing property that occurs when the critical speed is exceeded.

When placing timid children on a bicycle, it is desirable to provide stability augmentation and slower dynamics. These modifications make the bicycle more forgiving and easier to ride. Experience from behavior studies indicates that people, including children with disabilities, can learn, refine, and encode motor tasks as long as they have some success [75]. By adapting the bicycle, it is possible to create conditions so that children, including those with developmental challenges, can develop riding skills.

By making a bicycle more stable and easier to ride, we necessarily diminish maneuverability and thus restrict controllability in a system-theoretic sense. Getting a fearful first-time rider to be successful in staying upright while on a bicycle takes precedence over maneuverability. Thus, the program uses special bicycles with properties of enhanced stability and slower dynamics. Moreover, pedagogical methods have also been developed to use these bicycles to teach children with an array of disabilities and handicaps. The key is to design bicycles that behave like ordinary bicycles but with more benign dynamics.

The simple model given by (1) shows that the bicycle has an unstable mode with a pole approximately at $\sqrt{g/h}$ (2). The unstable mode can be made slower by replacing

the ordinary wheels with crowned rollers as shown in Figure 21, where the rocking radius R is the radius of the lateral curvature of the rollers. To model the system, we observe that the gravity term mgh in (1) is replaced by $mg(h - R)$. A bicycle with crowned rollers is stable if $R > h$, and unstable for $R < h$. The unstable pole

$$p = \sqrt{\frac{mg(h - R)}{J}} \approx \sqrt{\frac{(1 - R/h)g}{h}} \quad (27)$$

can be made arbitrarily slow by making R sufficiently close to h . The critical velocity also decreases with increasing h . By using crowned rollers and changing the gearing, it is possible to design bicycles that behave much like an ordinary bicycle, but which can be pedaled at a slower forward speed while maintaining its self-stabilizing ability.

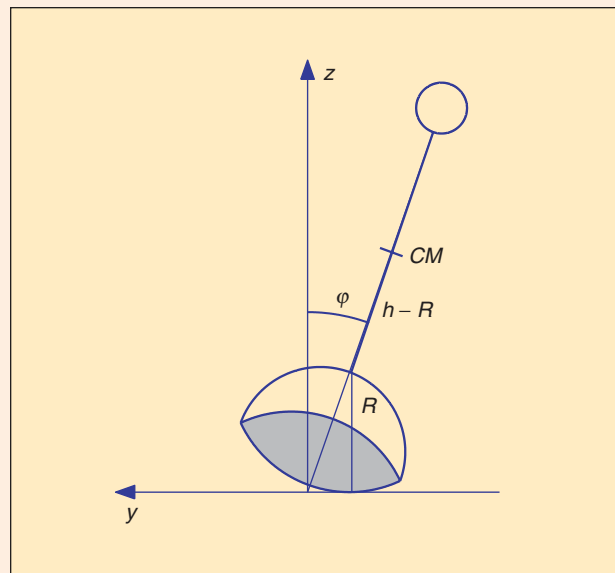

Figure 21. Schematic rear view of a bicycle with crowned rollers. The center of mass is CM, the lateral radius of the rollers is R , and h is the distance from the bottom of the roller to the center of mass. The horizontal displacement of the center of mass when the bicycle is tilted is $(h - R) \sin \phi$.

UIUC experiments, steer torque is measured using a torque wrench. Rider lean angle is measured using a potentiometer pivoted to the rear of the seat, attached to a vertical rod, and then attached to a vest worn by the rider. A dc voltage calibrated to rider lean angle is indicated by a voltmeter mounted on the handlebars in

view of the rider. Steer angle is also measured in a similar way. Velocity is measured using a common bicycle speedometer.

An experiment that can be conducted with basic instrumentation is to ride in a circle marked on the ground; a radius of 10 m is a good value. The objective of

The bicycle dynamics are adjusted by changing the rocking radius R of the rollers. For a timid child, we start with nearly flat rollers, which make the bicycle statically stable (see Figure 22). The rollers are replaced to make the open-loop capsized pole unstable but slow. The capsized pole is then successively made faster as the child acquires improved balance and riding skills. Some adapted bicycles have front and rear rollers, whereas more advanced adapted bicycles only have a rear roller (see Figure 23). When trained instructors observe that the child is participating in steering by turning into the direction of the lean, we advance the child onto bicycles that are more like conven-

tional bicycles but still retain some modifications. This approach helps children learn to ride conventional two wheelers. The approach is similar to the wind-surfer approach to adaptive control proposed in [76].

This therapy has been effective in over a dozen U.S.-based clinics for children and adults with a wide array of disabilities, including Down syndrome, autism, mild cerebral palsy, and Asperger's syndrome. The therapy has been applied to about 600 children from six to 20 years of age. The children typically enjoy the adapted bicycle program, and smiles abound. More details on the adapted bicycling program are available at <http://losethetrainingwheels.org>.



STEVE SMITH/DECKER'S STUDIO

Figure 22. A child on an entry-level adapted bicycle. The wheels are replaced with crowned rollers. Virtually all children love the idea of being independent bicycle riders. This child rides comfortably because the bicycle is stable. As the child becomes more proficient, we substitute rollers with more crown (smaller R in Figure 21) and eventually transition the children to conventional bicycles.



STEVE SMITH/DECKER'S STUDIO

Figure 23. A child on an adapted bicycle with a crowned roller on the rear wheel and a regular front wheel. The child is participating in steering by gently turning the handlebars into the direction of tilt.

the experiment is to use lean angle as the primary input, while steer torque is nulled to be maintained close to zero. Small adjustments of steer torque are required to maintain stability and the desired circular path. Another experiment is to keep the relative rider lean angle at 0° while applying the steer torque required to maintain the steady state turning. The experiment should be conducted at a

The front fork is essential for the behavior of the bicycle, particularly the self-stabilization property.

constant forward speed. The behavior of the system is different for speeds below and above the critical speed.

Stabilization

Many experiments can be done to illustrate instability and stabilization of riderless bicycles in various configurations. Start by holding the bicycle still and upright, and then release it to get a feel for the time constant of the basic instability of the stationary bicycle as an inverted pendulum. Then walk forward holding the bicycle in the saddle, observe the behavior of the front fork as the velocity is changed, and determine the self-alignment velocity (16).

The next sequence of experiments can be done on an open surface with a gentle down slope. One person starts the bicycle rolling with a firm initial push. Another person positioned downhill hits the bicycle sideways with a hand as the riderless bicycle passes. The impact causes a brief transient and then the self-stabilizing action restores the bicycle to a straight upright position, although the path of travel will be at a different angle. Give the bicycle a push downhill, and observe its self-stabilizing behavior. The downhill slope and initial speed should be sufficient so that the critical velocity is exceeded. Tests at different speeds combined with side impulse jabs will give a feel for the critical velocity. When the velocity is subcritical, a bicycle oscillates with growing amplitude when jabbed. Conversely, the oscillation is damped when the velocity is above the critical speed. Next, it is useful to see how critical velocity varies with trail and then with the addition of mass to the front wheel. A simple way to increase the mass of the front wheel is to wrap a lead cable or chains around the rim secured in place with tape around the circumference of the rim and tire (see Figure 14). This increased mass increases the gyroscopic action on the front wheel substantially and lowers the critical velocity.

Yet another experiment is to arrange a destabilizing torque spring to the front fork by attaching a rubber cord

between the steering neck stem and the seat post (see Figure 14). Although the rubber cord destabilizes the bicycle at zero velocity, stability improves at higher velocities because the front wheel reacts faster to the lean.

The Rocket Bike

A riderless bicycle is provided with a model rocket attached to one side of the handlebars so that it can create a torque on the front fork. In the experiment, the bicycle is pushed off in a straight direction. The rocket is ignited remotely. The startling counterintuitive result is that the path of travel resembles the one in Figure 5. Spectators are frequently astonished to see that the bicycle ends up turning in the opposite direction of the applied torque. This demonstration presents convincing empirical evidence that the bicycle is counterintuitive, aptly demonstrating the nonminimum phase character of the bicycle. Moreover, when pushed off, the bicycle either remains stable in a turn when its velocity is above the critical value, or it falls inward in an increasingly tighter turn if its velocity is below the critical value. The experiments can be combined with stability augmentation such as weighted wheels and differing trail configurations as described previously.

Rear-Wheel Steering

A bicycle with rear-wheel steering has many pedagogical uses. Almost everyone who tries to ride such a bicycle is surprised to find that a seemingly familiar device can exhibit such strange behavior. The rear-steered bicycle never fails to arouse interest in observers, young students as well as senior engineers, and provides an ideal tool for motivating students to study dynamics and control. A rear-steered bicycle can be used to illustrate the importance of integrated process and control design, the effects of poles and zeros in the right-half plane, and the fundamental limitations caused by bad system dynamics. Furthermore, a rear-steered bicycle can also lead into discussions about the role of sensors and actuators. An example is provided by the scenario given in "Control Is Important for Design."

A rear-steered bicycle built by Klein is shown in Figure 18. A regular bicycle can be converted to this configuration with a moderate effort. Trying to ride a rear-steered bicycle is a direct way to experience the difficulties of controlling a system with poles and zeros in the right-half plane. The bicycle in Figure 18 is unrideable as is a similar bicycle built in Lund. The simple analysis based on the second-order model (18) gives insight into what is required to ride a rear-steered

bicycle. The right-half-plane pole is fixed at $p \approx \sqrt{g/h}$, whereas the right-half-plane zero at $z \approx V/a$ depends on the velocity. The zero, which is at the origin at zero velocity, moves to the right with increasing velocity. To have good separation between the pole and the zero, it is desirable to have a large velocity V , a large height h , and a small distance from the contact point of the front wheel and the projection of the center of mass on the ground a . A bicycle with these properties has been built by Klein (see Figure 19) and can indeed be ridden successfully. The rear-steered UCSB bicycle in Figure 20 is designed to be rideable under certain conditions. One way is to start by leaning forward (making a small) and standing up on the pedals (making h large) and then pedaling rapidly to quickly reach a high speed. This skill takes fortitude, but several students and one faculty member, Roy Smith, have mastered the technique.

Conclusions

Control is becoming ubiquitous with an increasing number of applications in widely different areas. One reason for this success is the huge potential benefits of feedback: to reduce effects of disturbances and parameter variations, to change the dynamic behavior of systems, and to stabilize an unstable system. Another reason is the ease of implementation of control. An understanding of control is also essential for understanding the behavior of natural and man-made systems. The wider range of potential uses of feedback offers challenges to control. A recent panel for assessment of the field made the following recommendation:

The Panel believes that control principles are now a required part of any educated scientist's or engineer's background, and we recommend that the community and funding agencies *invest in new approaches to education and outreach for the dissemination of control concepts and tools to nontraditional audiences.* [73], [74]

When teaching control to students from a broader spectrum of disciplines, it is essential to strive for a balance between theory and application. This balance can be achieved by relating the abstract concepts to concrete and familiar systems. The bicycle allows us to help students understand dynamic behavior and to model and design control systems.

In this article, we have approached the bicycle from the point of view of control. By using models of different complexity, we explored interesting properties, for example, that the front fork creates feedback, which under certain circumstances stabilizes a bicycle, and

that rear-steered bicycles are difficult to ride. These properties can be explained qualitatively using simple models. More elaborate models that give quantitative results are also given. A number of experiments that can be performed with modest equipment have been described. Insights into dynamics and control have been used to develop adapted bicycles for children

Learning to ride a bicycle is an acquired skill, often obtained with some difficulty; once mastered, the skill becomes subconscious and second nature, literally just "as easy as riding a bike."

with cognitive and motor developmental disabilities. Clinical experiences from using adapted bicycles are also presented.

Acknowledgment

We would like to thank the reviewers for many useful suggestions on form and content.

References

- [1] D.V. Herlihy, *Bicycle—The History*. New Haven, CT: Yale Univ. Press, 2004.
- [2] W.J.M. Rankine, "On the dynamical principles of the motion of velocipedes," *Engineer*, vol. 28, pp. 79, 129, 153, 175, 1869.
- [3] C. Bourlett, *Traité des Bicycles et Bicyclettes*. Paris: Gauthier-Villars, 1898.
- [4] F.J.W. Whipple, "The stability of the motion of a bicycle," *Quart. J. Pure Appl. Math.*, vol. 30, no. 120, pp. 312–348, 1899.
- [5] E. Carvallo, "Théorie du mouvement du monocycle et de la bicyclette," *J. de L'Ecole Polytechnique*, vol. 5, pp. 119–188, 1900.
- [6] E. Carvallo, "Théorie du mouvement du monocycle. part 2: Theorie de la bicyclette," *J. d l'Ecole Polytechnique*, vol. 6, pp. 1–118, 1901.
- [7] A. Sharp, *Bicycles & Tricycles: A Classic Treatise on Their Design and Construction*. New York: Dover, 2003.
- [8] F.R. Whitt and D.G. Wilson, *Bicycling Science*, 2nd ed. Cambridge, MA: MIT Press, 1982.
- [9] D.G. Wilson, *Bicycling Science*, 3rd ed., with contributions by Jim Papadopoulos. Cambridge, MA: MIT Press, 2004.
- [10] F. Klein and A. Sommerfeld, *Über die Theorie des Kreisels*, vol. Heft IV. Leipzig, Germany: Teubner, 1910, pp. 863–884.
- [11] A.M. Letov, "Stability of an automatically controlled bicycle moving on an horizontal plane," *Appl. Math. Mechanics*, vol. 23, no. 4, pp. 650–655, 1959.

- [12] H. Fu, "Fundamental characteristics of single-track vehicles in steady turning," *Bull. Japanese Soc. Mech. Eng.*, vol. 9, no. 34, pp. 284–293, 1966.
- [13] D.E.H. Jones, "The stability of the bicycle," *Phys. Today*, vol. 23, pp. 34–40, Apr. 1970.
- [14] A.I. Krauter, "Steady-state cornering of two-wheeled vehicles," *J. Appl. Mechan.*, pp. 819–821, Sept. 1973.
- [15] S.S. Wilson, "Bicycle technology," *Sci. Amer.*, vol. 228, pp. 81–91, Mar. 1973.
- [16] T.R. Kane, "Fundamental kinematical relationships for single-track vehicles," *Int. J. Mech. Sci.*, vol. 17, no. 8, pp. 499–504, 1975.
- [17] J. Liesegang and A.R. Lee, "Dynamics of a bicycle: Non-gyroscopic effects," *Amer. J. Phys.*, vol. 46, no. 2, pp. 130–132, 1978.
- [18] D.H. Weir and J.W. Zellner, "Lateral directional motorcycle dynamics and control," Amer. Soc. Automotive Eng. SAE Paper 780304, 1978.
- [19] D. Kirshner, "Some non-explanations of bicycle stability," *Am. J. Phys.*, vol. 48, no. 1, pp. 36–38, 1980.
- [20] M. Kondo, "Experimental study on the stability and control of single-track vehicles," *Proc. Japan Soc. Mech. Eng.*, vol. 58, pp. 827–833, 1955.
- [21] J. Lowell and H.D. McKell, "The stability of bicycles," *Amer. J. Phys.*, vol. 50, no. 12, pp. 1106–1112, 1982.
- [22] Y. Le Henaff, "Dynamical stability of the bicycle," *Eur. J. Phys.*, vol. 8, no. 3, pp. 207–210, July 1987.
- [23] G. Franke, W. Suhr, and F. Rieß, "An advanced model of bicycle dynamics," *Eur. J. Phys.*, vol. 11, no. 2, pp. 116–121, 1990.
- [24] I.U.I. Neĭmark and N.A. Fufaev, "The stability of noncontrolled and controlled bicycles and motorcycle," *J. Mech. Solids*, vol. 2, no. 2, pp. 7–14, 1967.
- [25] I.U.I. Neĭmark and N.A. Fufaev, *Dynamics of Nonholonomic Systems*. Providence, Rhode Island: American Mathematical Society, 1972.
- [26] D.V. Singh, "Advanced concepts of the stability of two-wheeled vehicles—application of mathematical analysis to actual vehicles," Ph.D. dissertation, Univ. Wisconsin, Madison, WI, 1964.
- [27] R.S. Hand, "Comparisons and stability analysis of linearized equations of motion for a basic bicycle model," Masters thesis, Cornell Univ., Ithaca, NY, 1988.
- [28] D.H. Weir, "Motorcycle handling dynamics and rider control and the effect of design configuration on response and performance," Ph.D. dissertation, UCLA, 1972.
- [29] D.J. Eaton, "Man-Machine Dynamics in the Stabilization of Single-Track Vehicles," Ph.D. dissertation, Univ. Michigan, Ann Arbor, MI, 1973.
- [30] L.H. Laiterman, "Theory and applications of rear-wheel steering in the design of man-powered land vehicles," B.S. thesis, MIT, Cambridge, MA, 1977.
- [31] C. Koenen, "The dynamic behaviour of a motorcycle when running straight ahead and when cornering," Ph.D. thesis, Technische Hogeschool Delft, The Netherlands, 1983.
- [32] B.C. Mears, "Open loop aspects of two wheeled vehicle stability characteristics," Ph.D. thesis, Univ. Illinois, Urbana-Champaign, IL, 1988.
- [33] R.D. Roland, *Computer Simulation of Bicycle Dynamics*. New York: ASME, 1973.
- [34] N.H. Getz, "Control of balance for a nonlinear nonholonomic non-minimum phase model of a bicycle," in *Proc. Amer. Control Conf.*, Baltimore, MD, 1994, pp. 148–151.
- [35] N.H. Getz and J.E. Marsden, "Control for an autonomous bicycle," in *Proc. IEEE Conf. Robotics Control*, Nagoya, Japan, 1995, pp. 1397–1402.
- [36] W.S. Koon and J.E. Marsden, "The Hamiltonian and Lagrangian approaches to the dynamics of nonholonomic systems," *Rep. Math. Phys.*, vol. 40, no. 1, pp. 21–62, 2000.
- [37] S. Timoshenko and D.H. Young, *Advanced Dynamics*. New York: McGraw Hill, 1948, p. 239.
- [38] J.P. Den Hartog, *Mechanics*. New York: Dover, 1961, p. 328.
- [39] A.E. Bryson, *Applied Linear Optimal Control: Examples and Algorithms*. Cambridge, U.K.: Cambridge Univ. Press, 2002.
- [40] R.E. Roberson and R. Schwertassek, *Dynamics of Multibody Systems*. Berlin: Springer, 1988.
- [41] Anon., "Autosim 2.5+," Mechanical Simulation Corp., Tech. Rep., Ann Arbor, MI, 1998.
- [42] R. Von Schwerin, *Multibody System Simulation: Numerical Methods, Algorithms and Software*. Berlin: Springer, 2000.
- [43] M. Coutinho, *Dynamic Simulation of Multibody Systems*. Berlin: Springer, 2001.
- [44] A. Ahmed, *Dynamics of Multibody Systems*. Cambridge, U.K.: Cambridge Univ. Press, 2003.
- [45] M. Otter, H. Elmqvist, and S. Mattsson, "The new Modelica multi-body library," in *Proc. 3rd Int. Modelica Conf.*, Linköping, Nov. 3–4, 2003, pp. 311–330.
- [46] A. Lennartsson, "Efficient multibody dynamics," Ph.D. dissertation, Royal Inst. Tech., Stockholm, Sweden, 1999.
- [47] A.L. Schwab, "Dynamics of flexible multibody systems," Ph.D. dissertation, Delft Univ. Tech., Delft, Netherlands, 2002.
- [48] A.L. Schwab, J.P. Meijaard, and J.M. Papadopoulos, "Benchmark results on the linearized equations of motion of an uncontrolled bicycle," in *Proc. 2nd Asian Conf. Multibody Dynamics*, Aug. 1–4, 2004, Seoul, Korea, 2004, pp. 143–151.
- [49] D.J.N. Limebeer and R.S. Sharp, "Bicycles, motorcycles and models," submitted for publication.
- [50] R.S. Sharp, "The stability and control of motorcycles," *J. Mech. Eng. Sci.*, vol. 13, no. 5, pp. 316–329, 1971.
- [51] R.S. Sharp, "The dynamics of single track vehicles," *Vehicle Syst. Dynam.*, vol. 5, no. 1, pp. 67–77, 1975.
- [52] H.B. Pacejka, *Tyre and Vehicle Dynamics*. London, U.K.: Butterworth, 2002.
- [53] R.S. Sharp, "Vibrational modes of motorcycles and their design parameter sensitivities," in *Vehicle NVH and Refinement, Proc. Int. Conf. Birmingham Mech. Eng. Publ. London*, 1994, pp. 107–121.
- [54] R.S. Sharp and D.J.N. Limebeer, "A motorcycle model for stability and control analysis," *Multibody Syst. Dynam.*, vol. 6, no. 2, pp. 123–142, 2001.

- [55] R.S. Sharp, S. Evangelou, and D.J.N. Limebeer, "Advances in the modelling of motorcycle dynamics," *Multibody Syst. Dynam.*, vol. 12, no. 3, pp. 251–283, 2004.
- [56] P.A.J. Ruijs and H.B. Pacejka, "Research in the lateral dynamics of motorcycles," in *Proc. 9th IAVSD Symp. Dynamics Vehicles Roads Tracks*, 1996, pp. 467–478.
- [57] V.N. Fomin, A.L. Fradkov, and V.A. Yakubovich. *Adaptive Control of Dynamics Plants* (in Russian). Moscow: Nauka, 1981, pp. 14–22, pp. 257–268.
- [58] S. Lee and W. Ham, "Self stabilizing strategy in tracking control of an unmanned electric bicycle with mass balance," in *Proc. IEEE Conf. Intelligent Robots Systems*, Lausanne, Switzerland, 2002, pp. 2200–2205.
- [59] Y. Tanaka and T. Murakami, "Self sustaining bicycle robot with steering controller," in *Proc. IEEE Int. Workshop Advanced Motion Control AMC 2004*, Kawasaki, Japan, 2004, pp. 193–197.
- [60] R.E. Klein, L. Lieberman, P. DiRocco, and E. McHugh, "Adapted bikes deliver new independence," *Exceptional Parent*, vol. 32, no. 10, pp. 64–66, 2002.
- [61] R.E. Klein, E. McHugh, S.L. Harrington, T. Davis, and L. Lieberman, "Adapted bicycles for teaching riding skills," *Teaching Exceptional Children*, vol. 37, no. 6, 2005.
- [62] H. Goldstein, *Classical Mechanics*. Reading, MA: Addison-Wesley, 1953, p. 145.
- [63] S. Skogestad and I. Postlethwaite, *Multivariable Feedback Control: Analysis and Design*. Chichester, UK: Wiley, 1996.
- [64] K.J. Åström. "Limitations on control system performance," *Eur. J. Control*, vol. 6, no. 1, pp. 2–20, 2000.
- [65] H. Elmqvist, S.E. Mattsson, and M. Otter, "Modelica a language for physical system modeling, visualization and interaction," in *Proc. 1999 IEEE Symp. Computer-Aided Control Syst. Design, CACSD'99*, Hawaii, Aug. 22–27, 1999. [Online]. Available: <http://www.modelica.org>
- [66] M. Lesser, *The Analysis of Complex Nonlinear Mechanical Systems, a Computer Algebra Assisted Approach, of World Scientific Series on Nonlinear Science—Series A*. Singapore: World Scientific, 1995, vol. 17.
- [67] J.M. Papadopoulos, "Bicycle steering dynamics and self-stability: A summary report on work in progress," Cornell Bicycle Project, Cornell Univ., Ithaca, NY, Tech. Rep., 1987.
- [68] A. Sommerfeld, *Mechanics*. New York: Academic, 1952.
- [69] K.I.T. Richardson, *The Gyroscope Applied*. London: Hutchinson, 1954.
- [70] R.E. Klein, "Novel systems and dynamics teaching techniques using bicycles," in *Preprints Joint Amer. Control Conf. (JACC)*, Atlanta, GA, 1988, vol. 2, pp. 1157–1160.
- [71] R.E. Klein, "Using bicycles to teach system dynamics," *IEEE Control Syst. Mag.*, vol. 6, no. 4, pp. 4–9, 1989.
- [72] R.E. Klein, "The University of Illinois bicycle project," in *Proc. IFAC Workshop Advances Control Education*, Boston MA, Jun. 1991, pp. 133–138.
- [73] R.M. Murray, K.J. Astrom, S. Boyd, R.W. Brockett, and G. Stein, "Future directions in control in an information-rich world," *IEEE Control Syst. Mag.*, vol. 23, no. 2, pp. 20–33, 2003.
- [74] R.M. Murray, *Control in an Information Rich World—Report of the Panel on Future Directions in Control, Dynamics, and Systems*. Philadelphia, PA: SIAM, 2003.
- [75] G. Martin and J. Pear, *Behavior Modification; What It Is and How to Use It*. Englewood Cliffs, NJ: Prentice Hall, 2003, p. 123.
- [76] W.S. Lee, B.D.O. Anderson, I.M.Y. Mareels, and R. Kosut, "On some key issues in the windsurfer approach to adaptive robust control," *Automatica*, vol. 31, no. 11, pp. 1619–1636, 1995.
- [77] R. Schwarz, "Accident avoidance characteristics of unconventional motorcycle configurations," Warrendale, PA, SAE Paper 790258, 1979.
- [78] G. Stein, "Respect the unstable," *IEEE Control Syst. Mag.*, vol. 23, no. 4, pp. 12–25, 2003.
- [79] T.D. Crouch, *The Bishop's Boys—A Life of Wilbur and Orville Wright*. New York: Norton, 1989.

Karl J. Åström (kja@control.lth.se) received his M.Sc. in engineering physics in 1957 and his Ph.D. in control and mathematics in 1960 from the Royal Institute of Technology in Stockholm, Sweden. After graduating, he worked five years for IBM Research. In 1965, he became professor at Lund Institute of Technology/Lund University, where he built the new Department of Automatic Control. He is now emeritus at Lund University and part-time visiting professor at University of California in Santa Barbara. He is a Life Fellow of the IEEE. He has broad interests in control and its applications. He has received many awards, including the IEEE Medal of Honor and the Quazza medal from IFAC. He can be contacted at the Department of Automatic Control, Lund Institute of Technology, Box 118, SE-221 00 Lund, Sweden.

Richard E. Klein received his B.S. and M.S. degrees in mechanical engineering from Pennsylvania State University in 1964 and 1965, respectively. He received his Ph.D. from Purdue University, West Lafayette, in 1969. He served on the faculty of the University of Illinois in Urbana-Champaign, where he was instrumental in developing a teaching and research program related to bicycle dynamics. He is a Life Member of the IEEE. In 1998, he and his wife Marjorie created a program called *Lose the Training Wheel*, with emphasis on teaching children with disabilities to ride conventional bicycles (<http://www.losethetrainingwheels.org>).

Anders Lennartsson received his M.Sc. degree in aeronautical engineering in 1991 and his Ph.D. in mechanics in 1999, both from the Royal Institute of Technology, Stockholm. His thesis covered methods for describing models of mechanical systems using computer algebra and the conversion of symbolic equations of motion for numerical analysis; of particular interest were stability properties of fixed points and periodic orbits. He currently works at the Swedish Defense Research Agency, FOI, Stockholm, Sweden. His interests include inertial navigation, autonomous systems, submersibles, and non-holonomic mechanics.

