



MIT Open Access Articles

BiDirectional optical communication with AquaOptical II

The MIT Faculty has made this article openly available. **Please share** how this access benefits you. Your story matters.

Citation	Doniec, Marek, and Daniela Rus. "BiDirectional Optical Communication with AquaOptical II." IEEE International Conference on Communication Systems 2010 (ICCS). 390–394. © Copyright 2010 IEEE
As Published	http://dx.doi.org/10.1109/ICCS.2010.5686513
Publisher	Institute of Electrical and Electronics Engineers (IEEE)
Version	Final published version
Citable link	http://hdl.handle.net/1721.1/72543
Terms of Use	Article is made available in accordance with the publisher's policy and may be subject to US copyright law. Please refer to the publisher's site for terms of use.

BiDirectional Optical Communication with AquaOptical II

Marek Doniec, Daniela Rus
Computer Science and Artificial Intelligence Lab
Massachusetts Institute of Technology
Cambridge, MA 02139, USA
Email: {doniec, rus}@csail.mit.edu

Abstract—This paper describes AquaOptical II, a bi-directional, high data-rate, long-range, underwater optical communication system. The system uses the software radio principle. Each AquaOptical II modem can be programmed to transmit user defined waveforms and record the received waveforms for detailed analysis. This allows for the use of many different modulation schemes. We describe the hardware and software architecture we developed for these goals. We demonstrate bi-directional communication between two AquaOptical II modems in a pool experiment. During the experiment AquaOptical II achieved a signal to noise ration of 5.1 over a transmission distance of 50 m at pulse widths of 1 μ sec, 500 ns, and 250 ns. When using discrete pulse interval modulation (DPIM) this corresponds to a bit-rate of 0.57 Mbit/s, 1.14 Mbit/s, and 2.28 Mbit/s.

I. INTRODUCTION

Our goal is to develop persistent long-term ocean observatories that can monitor and survey underwater habitats. To this end, we are developing underwater sensor networks [1], [2], [3]. An underwater sensor network integrates computation, communication, sensing, and supporting algorithms. Both hardware and software components of the system have to address the characteristics of the sub-sea environment. A critical component of an underwater observatory is its ability to transmit data collected in-situ from sensors. Traditionally, underwater data transfers rely on acoustic communications, which achieve long-distance broadcast at slow data rates with high-power consumption. Two examples are the commercially available WHOI acoustic modem [4] and the Benthos modem [5].

In this paper, we investigate optical communication as an alternative to acoustic systems for communication underwater. Optical communication underwater achieves much higher data transfer rates than an acoustic communication system at significantly lower power consumption, simpler computational complexity, and smaller packaging. However, they operate in a point-to-point communication setting, where both the receiver and the transmitter are usually directional and require alignment for the communication to work effectively. Further, their range and scope is affected by the water clarity, water light absorption, and power loss due to propagation spherical spreading. We believe that an effective method for large-scale data transfers (which are required when uploading the data collected by an underwater sensor network) is to optical data



Fig. 1. Two AquaOptical II modems.

muling. In optical data muling, a robot equipped with an optical modem visits each node of the sensor network and uploads its data while hovering within optical communication range. In our previous work [1], we described an underwater sensor network system capable of uni-directional optical data muling. However, the performance of the optical modems was low. This paper describes a second generation optical communication system that is bi-directional and improves over the previous version in data rate, range, power use, and capability.

II. RELATED WORK

There has been a significant amount of research on underwater optical communication since the appearance of high powered blue-green lasers and LEDs. A number of studies explored the theory of optical transmission in water and suggested possible optical modem designs [6], [7], [8], [9]. Tsuchida *et al.* reported an early underwater analog communication system for wirelessly monitoring crayfish neuronal activity in [10]. Schill *et al.* presented an underwater optical system based on blue-green LEDs and conventional photodiodes combined with an IrDA physical layer [11]. Hanson and Radic demonstrated the use of waveguide modulated optical lasers for high speed optical communication [12]. The device is, however, directional, very bulky and expensive due to the difficulty in directly modulating green laser at high speed. Farr *et al.* presented the results of an early prototype optical communication system for sea floor observatories [13]. More

recently, they reported full-duplex optical underwater communication using separate optical wavelength channels [14]. Communication using separate optical wavelengths requires a separate receiver for every wavelength and is thus hard to expand beyond two modems. Their system operates at depths of at least 1000m where there is little or no ambient light present.

We reported the first use of short-range optical communication for underwater networking in [1], [3]. We presented the details of our hybrid short and long range optical modem system called AquaOptical in [15]. This paper presents improvements to AquaOptical in hardware and software.

III. SYSTEM DESIGN

A. Software defined radio approach

Two AquaOptical II modems can be seen in Figure 1. We designed this version of AquaOptical II specifically with a software defined radio approach in mind. This means that we can generate arbitrary transmission waveforms within the constraints of the LED drive circuitry and that the received waveform is digitized and stored as a whole, with little or no pre-processing. The software defined radio design allows us to test different encoding and decoding algorithms and to switch these on the fly in the field. Since such an approach generates significant amounts of data (up to 60 MB/sec for this receiver) it can limit the throughput of the modem (while the base bandwidth stays unaffected). However, we can directly implement encoding schemes such as Digital Pulse Interval Modulation (DPIM) inside the FPGA located in the modem, as demonstrated in the previous version of AquaOptical, which offered less computational power. We designed AquaOptical II for theoretical operation of up to 10 MBit/sec in the case that the encoder and decoder are located entirely inside the FPGA.

B. Hardware

Figure 2 shows the hardware components of AquaOptical II and Figure 3 gives presents a system overview. AquaOptical II is designed as a bidirectional communication device where each unit can both send and received data. Each modem is contained inside a water-tight tube of 8 cm diameter and 35 cm length and weights 2000 g. The transmitter and receiver are both housed at the front part of the tube, which is made from Aluminum for heat dissipation. The remaining part of the tube contains the electronics and a power source. To protect the internal components from water damage all seals have been designed using two o-rings each.

The transmitter consists of an array of 18 Luxeon Rebel LEDs that emit 470 nm light. The total light output in radiant flux is 10 W¹. We measured the LEDs operational range at up to 5 MHz with a minimum pulse length of 100 ns. An ARM7 processor, together with a Field-Programmable Gate Array (FPGA), and an additional drive stage are used to control the

¹Each LED is driven at 600 mA and outputs approximately 35lm at 470nm [16]. $18LEDs \cdot 35lm/LED \cdot 16mW/lm \approx 10W$

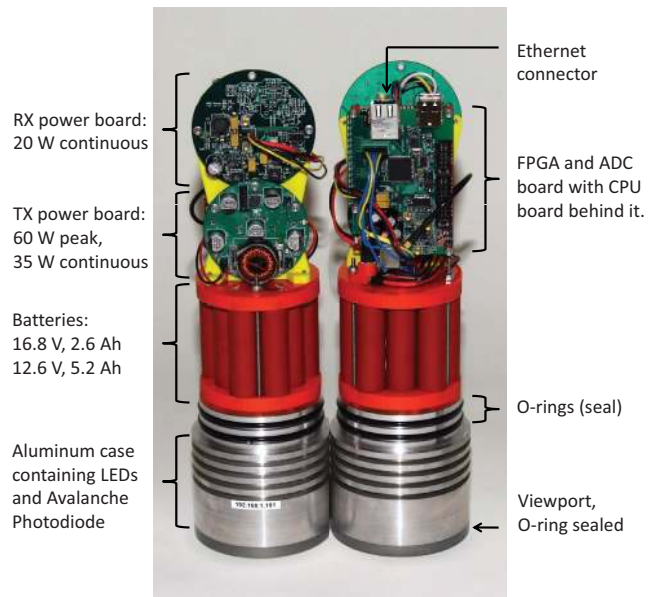

Fig. 2. Two AquaOptical II modems with the acrylic housing removed.

LEDs. The processor is used to encode user data to be sent and forwards a raw discrete (on/off) waveform to the FPGA. The FPGA buffers the waveform while it waits for the medium to be free (no light pulses detected for a preset amount of time). It then outputs the waveform onto the LEDs. Waveforms can be output at a rate of up to 40 Mega samples per second allowing for a fine-grained resolution of pulse positions within the signal. The waveforms buffer is written by the CPU using a Serial Peripheral Interface (SPI) running at 9 MHz.

The receiver consists of an Avalanche Photo-diode, which includes a low-noise amplifier and is thermoelectrically cooled. An analog-to-digital converter (ADC) converts the resulting signal into a stream of 12-bit words by sampling at up to 40 Mega samples per seconds. The digitized data stream is then analyzed the the same FPGA used for transmission. The FPGA uses a matched filter to detect single pulses. If a train of a preset number of pulses is detected, the FPGA records up to 12,288 samples into a buffer. This buffer is then transmitted to the CPU processor for decoding using a 16 Bit parallel bus running at 1 MHz.

C. Software

The AquaOptical II software is divided into two parts: (1) The software inside the FPGA which controls the transmission and sampling timing as well as packet detection and (2) the software inside the CPU which provides an interface to the user through the User Datagram Protocol (UDP).

The software inside the FPGA forms the heart of the system. It handles the following tasks:

- 1) Checking if the medium is busy to avoid packet collisions. This is done using a matched filter with an expected pulse shape that can be programmed attached to a pulse detector. After every pulse the medium is marked as busy for a preset time.

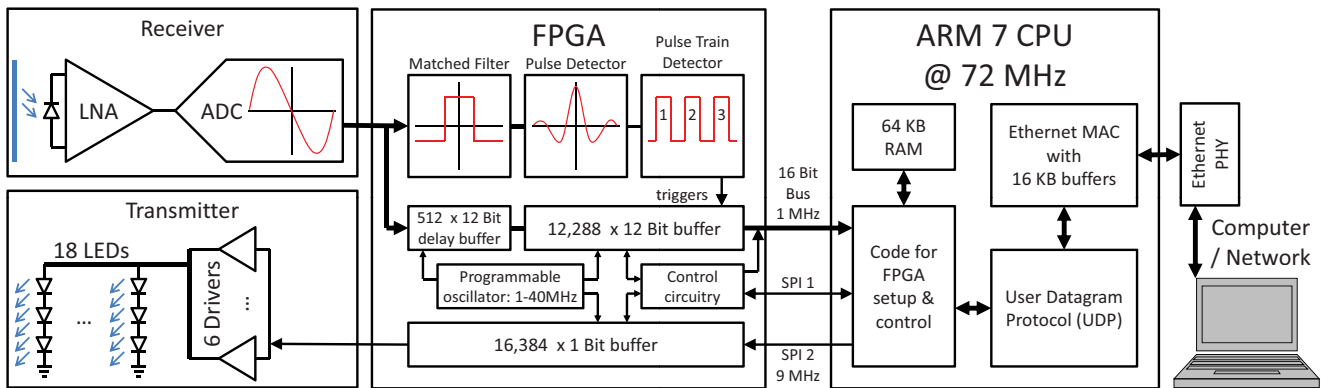

Fig. 3. Overview of the AquaOptical II hardware and software. The hardware consists of a transmitter and a receiver module, and FPGA, and a CPU. The hardware is described in detail in section III-B. The software modules are located inside the FPGA and CPU and are described in section III-C.

- 2) Detecting new data transfers (packets). A counter is used to count pulses that occur within a preset distance of each other. The detection of such a pulse train will trigger the receiving buffer to record data. This prevents single pulse detections caused by noise to trigger unnecessary recordings.
- 3) Buffering and transmitting waveforms at a preset sample rate when the medium becomes free. A 16,384 Bit long buffer is used for this purpose. It can be written to by the CPU using a 9 Mbit/sec SPI bus. Once the data is marked as valid by the CPU the FPGA will wait for the medium to become available and will immediately start transmitting the waveform.
- 4) Continuously pre-buffering the signal so that when a packet is detected the waveform is recorded including samples ahead of the packet. This serves to compute the amplitude of the noise and to possibly detect pulses that we missed by the FPGA internal detector. A 512 sample deep buffer is used to continuously delay the incoming signal before it reaches the record buffer.
- 5) Record the waveform upon packet detection. The waveform is recorded into a 12,288 sample deep buffer. The buffers size is limited by the memory available inside the FPGA.

The software inside the CPU provides an interface to the user through the use of UDP. It handles the following tasks:

- 1) Receive commands over the network to set configuration values inside the FPGA, such as the oscillator to a desired frequency. This will affect the sample rate for transmission and reception. Further configuration parameters are the desired matched filter shape, the number of pulses needed to trigger a recording, and the ability to shut down the receiver to reduce energy consumption².
- 2) Receive commands to transmit a waveform. The waveform is first cued inside the CPU and sent to the FPGA as soon as its transmit buffer becomes available (i.e. the

²The transmitter circuitry consumes no significant amounts of energy when not transmitting and has thus no option to shut it down.

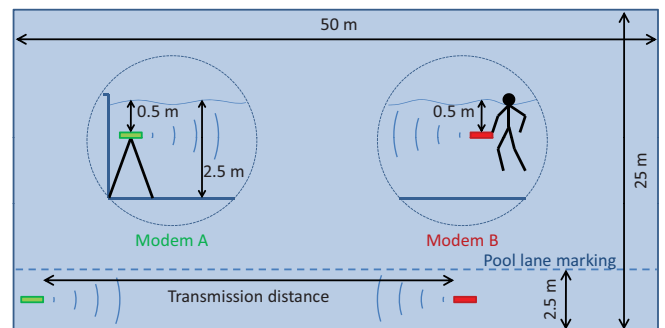

Fig. 4. Experimental Setup: Top view of the Olympic size pool (50 m x 25 m) with side views in the dotted circles. Modem A (green, left) was mounted on a tripod. Modem B (red, right) was held by a swimmer. See section IV-A for details.

previous waveform was sent).

- 3) Transmit received waveforms over UDP back over the network to the host machine. The host machine is determined by remembering the IP address of the last machine that sent a configuration packet.

IV. EXPERIMENTS

We designed an experiment to test two aspects of AquaOptical II simultaneously: (1) The ability to send and receive packets bi-directionally and (2) the signal to noise ratio (SNR) at distances up to 50m.

A. Experimental Setup

Figure 4 shows the experimental setup. We performed the experiment in a 50m long side lane of an Olympic size pool. The lane was 2.5 m wide and 2.5 m deep and the modems were positioned at approximately 0.5 m depth. We mounted the first modem (modem A) on a tripod at the left end of the lane. It was pointing towards the right end of the lane. A swimmer held the second modem (modem B) and pointed it towards modem A. Two Ethernet cables fitted with underwater connectors connected the modems to an Ethernet switch. We used a laptop computer running connected to the same switch

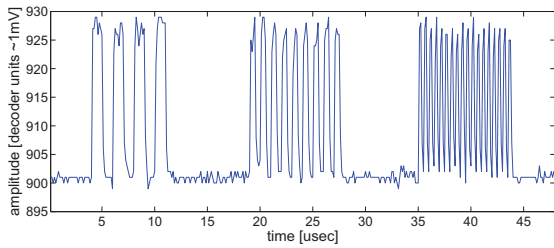

Fig. 5. Sample waveform transmitted by modem A and recorded by modem B. The x-axis shows the time in microseconds. The y-axis indicates the recorded APD output in decoder units (roughly 1 mV). The signal was sampled at 8 Mega samples per second. The width of the pulses for the three groups are, from left to right: 1 μ sec (0.5 MHz), 500 nsec (1 MHz), 250 nsec (2 MHz).

to setup and control the modems. For the purpose of this experiment we wrote a user interface in Java that sent 10 test waveforms every seconds from each modem and recorded all received waveforms. We sent waveforms composed of 1 μ s, 500 ns, and 250 ns long pulses spaced at different intervals and sampled at 8 MHz. A sample waveform sent by one modem and recorded by the other can be seen in Figure 5. When using discrete pulse interval modulation (DPIM) with 2 bits per pulse (4 different intervals) these pulse widths corresponds to average bit-rates of 0.57 Mbit/s, 1.14 Mbit/s, and 2.28 Mbit/s. The three pulse trains visible in Figure 5 encode one, two, and four zero-bytes data respectively when decoded using DPIM.

During the experiment the swimmer positioned himself above pool lane markers spaced every 2.5m along side the entire lane. At each marker we collected several hundred waveforms. The first waveforms were collected at a transmission distance of 7.5 m and the last at a transmission distance of 50 m.

B. SNR Computation

We used the collected waveforms to compute the signal strength and noise levels for each tested transmission distance. We defined the noise level as the standard deviation of the waveform parts where no pulses were present. We used a matched filter together with a pulse detector and counter identical to the one used in the FPGA to detect pulse trains. We then analyzed each waveform containing a pulse train as follows:

- We used the mean value of all sensor readings in the waveform to threshold between data points that represented a pulse reading and data points that represented readings where no pulse was present.
- We defined the noise level as the standard deviation of all waveform samples where no pulse was present.
- We defined the signal strength as the difference between the mean of all samples where and pulse was present and the mean of all samples where no pulse was present.
- For each measured transmission distance we averaged all noise levels and signal strengths to get one noise level and one signal strength for that particular distance.

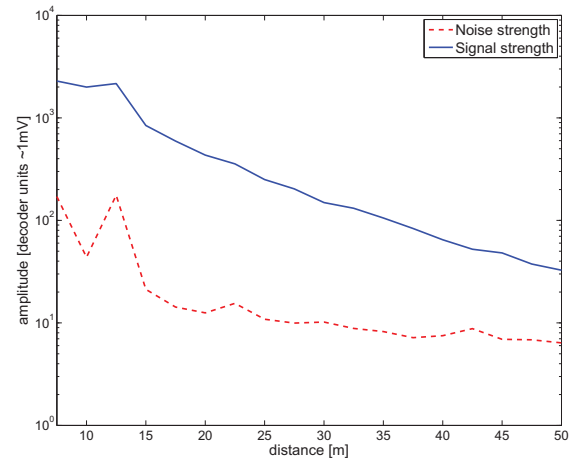

Fig. 6. Signal Strength vs Noise Strength. The x-axis indicates the transmission distance. The y-axis is logarithmic and indicates signal and noise strength in decoder units (roughly 1 mV). The blue line indicated signal strength and the red line noise levels. The beginning of the signal strength curve is capped at about 2,300 because the sensor was saturated. This is also the reason for increased noise at short distances.

- We computed the SNR for each distance by dividing the signal strength by the noise levels for that particular distance.

C. Results

The modems both successfully transmitted and received all waveforms at distances up to 21 m. This shows that AquaOptical II is capable of bi-directional communication, in particular that it successfully avoids packet collisions. At the 21 m one of the receivers unexpectedly shut down due to a software bug and we continued the experiment with a single receiver active up to a distance of 50 m to compute the SNR.

Figure 6 shows the results for the computed noise levels (red dotted line) and signal strengths (blue solid line). The low noise amplifier of the Avalanche Photodiode operates at a range of 0-3.3 V. The ambient light in the pool resulted in an offset of 1.1 V. This capped the signal strength at a maximum of 2.2 V as is visible for measurements at 12.5 m and below. Further when the amplifier is saturated it begins to oscillate. This is the reason for increased noise levels for measurements at 12.5 m and below.

We measured the best SNR of 45 at 15 m and the worst SNR of 5.1 at a distance of 50 m. Across the entire range the signal was always strong enough to decode all bits.

Assuming perfect spherical spreading of the signal we compute an e-folding length of 36 m. An e-folding length is the distance it takes for the signal to drop to $1/e$ of its original value. For clear water and a wavelength of 470 nm this should lie within 20 - 50 m. Matlab performed this fit with a 95% confidence bound and an R-square value of 0.97.

V. CONCLUSION AND FUTURE WORK

We presented both the hardware and the software of AquaOptical II. We performed experiments to show that it is capable of bi-direction communication at up to 50m. We could not perform measurements for transmission distances beyond 50 m because of pool size limitations. However given a SNR of 5.1 at 50m and the computed e-folding factor of 36 m we can predict a SNR of 2.7 at a transmission distance of 60 m and 1.1 at 75 m. Further the SNR for our experiment can be increased by sampling the signal at 40 MHz instead of 8 MHz and averaging the values which will reduce the noise level.

Because we designed AquaOptical II as a 'software defined radio' optical modem it will allow for testing and direct comparison of different modulations techniques. This is further aided by interfacing the modem via Ethernet.

We are currently working on implementing an Ethernet bridge using AquaOptical II. This will allow us to wirelessly control fleets of underwater robots while sending back video and measurement data. In the long term we envision a wireless underwater communication network similar to WiFi.

ACKNOWLEDGMENT

This work was supported by the DSTA, Singapore, and the MURI Antidote project. The authors are grateful for this support. The authors would like to thank Sareena Avadhany, Mark Guttag, and Wil Selby for their assistance.

REFERENCES

- [1] I. Vasilescu, K. Kotay, D. Rus, M. Dunbabin, and P. Corke, "Data collection, storage, and retrieval with an underwater sensor network," in *SensSys*, 2005, pp. 154–165.
- [2] I. Vasilescu, C. Detweiler, M. Doniec, D. Gurdan, S. Sosnowski, J. Stumpf, and D. Rus, "Amour v: A hovering energy efficient underwater robot capable of dynamic payloads," *International Journal of Robotics Research (IJRR)*, 2010.
- [3] C. Detweiler, I. Vasilescu, and D. Rus, "An underwater sensor network with dual communications, sensing, and mobility," in *OCEANS*, Aberdeen, Scotland, June 2007.
- [4] L. Freitag, M. Grund, S. Singh, J. Partan, P. Koski, and K. Ball, "The whoi micro-modem: an acoustic communications and navigation system for multiple platforms," in *Proc MTS/IEEE OCEANS*, Washington, DC, Sept. 2005.
- [5] (2010) Undersea, geophysical equipment, survey sonar and rov. [Online]. Available: <http://www.benthos.com>
- [6] M. A. Channey, "Short range underwater optical communication links," Master's thesis, North Carolina State University, 2005.
- [7] J. Smart, "Underwater optical communications systems part 1: variability of water optical parameters," in *Military Communications Conference*, 2005, pp. 1140–1146 Vol. 2.
- [8] B. Cochenour, L. Mullen, A. Laux, and T. Curran, "Effects of multiple scattering on the implementation of an underwater wireless optical communications link," in *OCEANS*, Boston, MA, Sept. 2006.
- [9] J. Giles and I. Bankman, "Underwater optical communications systems. part 2: basic design considerations," *Military Communications Conference*, pp. 1700–1705 Vol. 3, Oct. 2005.
- [10] Y. Tsuchida, H. N., and T. M., "An optical telemetry system for underwater recording of electromyogram and neuronal activity from non-tethered crayfish," *Journal of Neuroscience Methods*, vol. 137, pp. 103–109, 2004.
- [11] F. Schill, U. R. Zimmer, and J. Trunpf, "Visible spectrum optical communication and distance sensing for underwater applications," in *Australasian Conference on Robotics and Automation*, Canberra, Australia, 2004.
- [12] F. Hanson and S. Radic, "High bandwidth underwater optical communication," *Appl. Opt.*, vol. 47, no. 2, pp. 277–283, 2008.
- [13] N. Farr, A. Chave, L. Freitag, J. Preisig, S. White, D. Yoerger, and F. Sonnichsen, "Optical modem technology for seafloor observatories," in *OCEANS*, Boston, MA, Sept. 2006.
- [14] N. Farr, A. Bowen, J. Ware, and C. Pontbriand, "An integrated, underwater optical / acoustic communications system," in *Proc MTS/IEEE OCEANS*, Seattle, WA, Sept. 2010.
- [15] M. Doniec, C. Detweiler, I. Vasilescu, M. Chitre, M. Hoffmann-Kuhnt, and D. Rus, "Aquaoptical: A lightweight device for high-rate long-range underwater point-to-point communication," *Marine Technology Society Journal*, vol. 44, no. 4, pp. 55–65, July/August 2010.
- [16] (2010) LUXEON Rebel Direct Color data sheet. [Online]. Available: <http://www.philipslumileds.com/uploads/36/DS65-pdf>