

Bimolecular Fluorescence Complementation (BiFC) Analysis as a Probe of Protein Interactions in Living Cells

Tom K. Kerppola

Howard Hughes Medical Institute and Department of Biological Chemistry, University of Michigan Medical School, Ann Arbor, Michigan 48109-0650; email: kerppola@umich.edu

Annu. Rev. Biophys. 2008. 37:465–87

First published online as a Review in Advance on March 26, 2008

The *Annual Review of Biophysics* is online at biophys.annualreviews.org

This article's doi:
10.1146/annurev.biophys.37.032807.125842

Copyright © 2008 by Annual Reviews.
All rights reserved

1936-122X/08/0609-0465\$20.00

Key Words

fluorescence imaging, subcellular localization, visualization of molecular complexes, multicolor BiFC analysis

Abstract

Protein interactions are a fundamental mechanism for the generation of biological regulatory specificity. The study of protein interactions in living cells is of particular significance because the interactions that occur in a particular cell depend on the full complement of proteins present in the cell and the external stimuli that influence the cell. Bimolecular fluorescence complementation (BiFC) analysis enables direct visualization of protein interactions in living cells. The BiFC assay is based on the association between two nonfluorescent fragments of a fluorescent protein when they are brought in proximity to each other by an interaction between proteins fused to the fragments. Numerous protein interactions have been visualized using the BiFC assay in many different cell types and organisms. The BiFC assay is technically straightforward and can be performed using standard molecular biology and cell culture reagents and a regular fluorescence microscope or flow cytometer.

Contents

INTRODUCTION.....	466	Fluorescence	
VISUALIZATION OF PROTEIN		Complementation.....	474
INTERACTIONS.....	467	APPLICATIONS OF BiFC	
An Abbreviated History of		ANALYSIS.....	475
Complementation Assays.....	467	Subcellular Localization	
Comparison of the BiFC Approach		of Protein Complexes.....	475
and Other Complementation		Signal Transduction Networks....	476
Assays.....	468	Protein Interactions Associated	
Comparison of BiFC Analysis		with Cytokinesis.....	476
with Alternative Visualization		Interactions on Scaffolds.....	476
Methods.....	469	Visualization of Interactions	
DESIGN OF BiFC		in Living Organisms.....	477
EXPERIMENTS.....	470	Interaction Screens Using	
Choice of Fluorescent Protein		BiFC Analysis.....	477
Fragments.....	470	SIMULTANEOUS	
Conditional Association of		VISUALIZATION OF	
Fluorescent Protein		MULTIPLE PROTEIN	
Fragments.....	470	INTERACTIONS.....	477
Steric Constraints to the		Comparison of the Distributions	
Association of the Fluorescent		of Multiple Protein Complexes	
Protein Fragments.....	471	in the Same Cell.....	477
Detection of Transient		Comparison of the Efficiencies of	
and Weak Complexes.....	471	Complex Formation Between	
Controls.....	472	Alternative Interaction	
INTERPRETATION OF BiFC		Partners.....	478
EXPERIMENTS.....	472	Design of Multicolor BiFC	
Effects of Fusions on Protein		Experiments.....	479
Functions.....	472	Applications of Multicolor BiFC	
Dynamics of Bimolecular		Analysis.....	479
Fluorescent Complexes.....	473	SUMMARY AND FUTURE	
The Efficiency of Bimolecular		PROSPECTS.....	479

INTRODUCTION

Many proteins have different functions in various cell types and in response to distinct extracellular signals. The effects of the cellular environment on protein functions are often mediated by interactions with different partners under different conditions. Protein interactions also integrate signals from different signaling pathways and developmental programs and coordinate regulatory mechanisms in the cell. Studies of protein interac-

tions in living cells can provide insights into these functions, as interactions with different partners may occur in different cells, at different times, and in different subcellular locations. The visualization of interactions in individual cells also enables analysis of differences among different cells in the population. Studies in intact cells also avoid the possibility of changes in protein interactions as a result of cell lysis and mixing of the contents of different cellular compartments. Consequently,

the direct visualization of protein complexes in living cells provides a valuable complement to other methods for the study of protein interactions.

VISUALIZATION OF PROTEIN INTERACTIONS

Several methods enable the visualization of protein interactions in living cells. Most of these methods require either elaborate instrumentation and complex data processing, or staining with exogenous fluorophores or dyes. The bimolecular fluorescence complementation (BiFC) assay enables simple and direct visualization of protein interactions in living cells (44). The BiFC approach is based on the formation of a fluorescent complex when two proteins fused to nonfluorescent fragments of a fluorescent protein interact with each other (Figure 1). The interaction between the fusion proteins facilitates the association between the fragments of the fluorescent protein. This approach enables visualization of the subcellular locations of specific protein complexes in the normal cellular environment. The BiFC approach can be used for the analysis of interactions between many types of proteins and does not require information about the structures of the interaction partners. It can be performed using a standard epifluorescence microscope and does not require staining of the cells with exogenous fluorophores or dyes.

An Abbreviated History of Complementation Assays

Protein complementation has now been studied for about half a century. Fragments of many proteins can associate with each other to form a functional complex. Complementation between enzyme fragments was originally observed by Richards (96) using subtilisin-cleaved bovine pancreatic ribonuclease. Genetic complementation between different alleles of the same gene was characterized by Ullmann, Jacob, and Monod (113–115), who

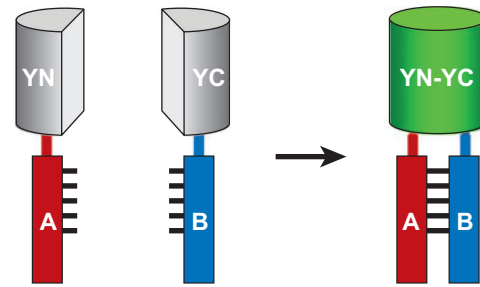

Figure 1

Schematic representation of the principle of the BiFC assay. Two non-fluorescent fragments (YN and YC) of the yellow fluorescent protein (YFP) are fused to putative interaction partners (A and B). The association of the interaction partners allows formation of a bimolecular fluorescent complex.

used β -galactosidase mutants that conferred growth on lactose when coexpressed in the same cell. Subsequently, fragments of many proteins have been shown to spontaneously associate to form a functional complex.

Of particular significance for the study of protein interactions was the demonstration that the association between some protein fragments could be facilitated by fusion of the fragments to specific interaction partners as first demonstrated for fragments of ubiquitin in yeast by Johnsson & Varshavsky (50). Subsequently, conditional complementation between fragments of β -galactosidase was visualized by Blau and coworkers (97) in intact mammalian cells. Conditional complementation by fragments of dihydrofolate reductase was reported by Michnick and colleagues (87).

Complementation between fragments of a green fluorescent protein (GFP) variant was first detected in *Escherichia coli* by Regan and coworkers (33) using fusions to artificial, interacting peptides. Fragments of the yellow fluorescent protein (YFP) were shown to produce fluorescent complexes in mammalian cells when fused to calmodulin and the M13 calmodulin binding peptide by the Miyawaki laboratory (74). Conditional complementation between fragments of YFP in mammalian cells was demonstrated by Hu in my laboratory (44). Fragments of several other proteins have been used in conditional complementation assays (Table 1) (55). Each

Table 1 Comparison of complementation methods using fragments of different proteins

Protein	Detection	Spatial resolution ^a	Time resolution ^a	Experimental systems ^a	Reference
Ubiquitin	Ub-protease coupled reporters	Cell population	Day	Yeast	(97)
β-galactosidase	FDG hydrolysis	Cellular	Hours	Cultured cells, <i>Drosophila melanogaster</i>	(50)
Dihydrofolate reductase	Fl-MTX binding	Sub-cellular	Minutes	Cultured cells, plants	(87)
GFP variants	Intrinsic fluorescence	Sub-cellular	Minutes–hours	Cultured cells, plants, fungi, bacteria	(33, 44)
<i>Synechocystis</i> dnaE intein	Reporter ligation	Cell population	Hours	Cultured, implanted cells	(79)
β-lactamase	CCF2/AM hydrolysis	Cellular	Minutes	Cultured cells, primary neurons	(32, 104, 121)
Firefly luciferase	Luciferin hydrolysis	Cell population	Hours	Cultured, implanted cells	(85)
<i>Renilla</i> luciferase	Coelenterazine luminescence	Cell population	Minutes–hours	Cultured, implanted cells	(84)
<i>Gaussia</i> luciferase	Coelenterazine luminescence	Cell population	Minutes	Cultured cells	(94)
TEV protease	Coupled reporters	Cellular	Minutes	Cultured cells	(120)

^aThe spatial and temporal resolution as well as the experimental systems used reflect those reported in publications using these approaches are not intended to represent the limits of performance of these methods.

complementation approach has specific advantages and limitations. This chapter focuses on complementation between fragments of fluorescent proteins.

The structures of the complexes formed by complementation have not been determined. However, it is likely that the structures resemble those of the intact proteins because they reproduce many of their functions (**Figure 2**). Proteins with a variety of structures can be reconstituted from fragments. However, only a few of the peptide bonds in any particular protein can be broken to produce fragments that can associate to form a functional complex. This limitation may reflect the folding pathways of the respective proteins. Greater insight into the folding pathways of complexes formed by the protein fragments would be valuable for understanding the factors that determine which protein fragments can associate to produce a functional complex.

Comparison of the BiFC Approach and Other Complementation Assays

The advantage of the BiFC approach compared to other complementation methods is that the assembled complex has strong intrinsic fluorescence that allows direct visualization of the protein interaction. The interaction can therefore be detected without exogenous fluorogenic or chromogenic agents, avoiding potential perturbation of the cells by these agents. This also avoids potential problems caused by uneven distributions of the chromogenic or fluorogenic substrates or ligands. Using the BiFC approach, living cells can be observed over time and the possibility that experimental manipulations alter the result can be minimized. Moreover, as described below, multiple protein interactions can be visualized in parallel using spectrally distinct bimolecular fluorescent complexes.

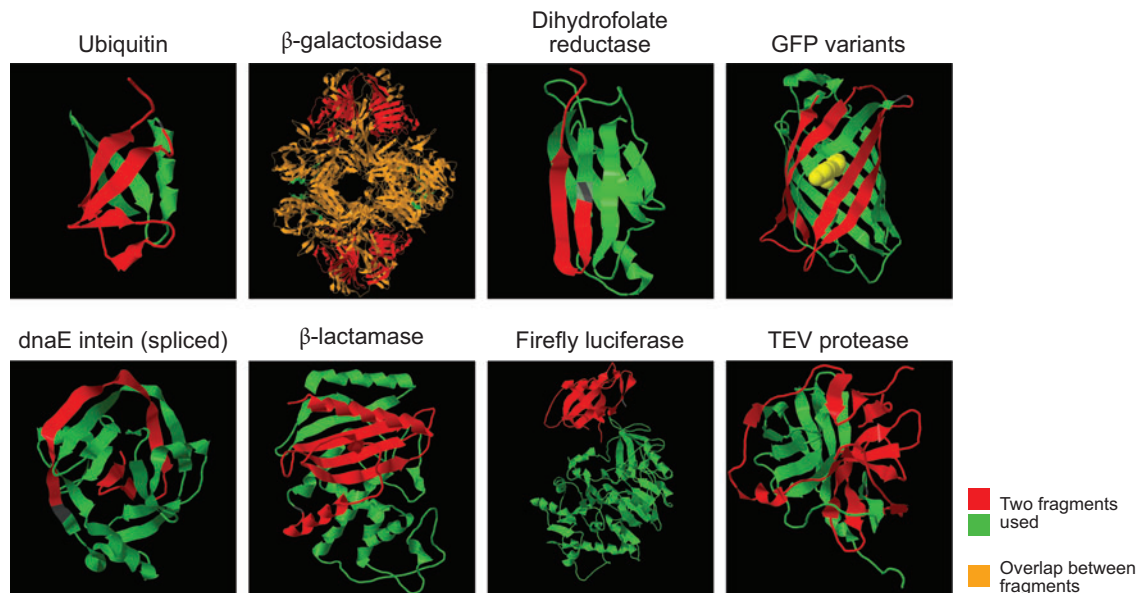

Figure 2

Structures of proteins that have been used to study protein interactions using complementation approaches. The two fragments that have been used are shown in red and green based on the X-ray crystal structures of the intact proteins. In β -galactosidase, the overlap between the fragments is shown in orange. The images were generated using Jmol.

One limitation of the BiFC approach is that there is a delay between when the fusion proteins interact with each other and when the complex becomes fluorescent (44). This delay is due to the slow rate of the chemical reactions required to produce the fluorophore. The length of the delay depends on the sensitivity of the detection method, as it is not necessary for all complexes to become fluorescent in order to observe the interaction. Nevertheless, the BiFC approach does not enable real-time detection of complex formation. In addition, formation of some bimolecular fluorescent complexes is irreversible at least *in vitro* (44). These characteristics limit the BiFC assay to detection of the average efficiencies of complex formation over relatively long times (minutes to hours). Despite these limitations, the BiFC assay has been useful for the investigation of interactions among a variety of structurally diverse proteins in many different cell types and organisms (56). Thus, the BiFC assay is gener-

ally applicable for the visualization of a variety of protein complexes in living cells and organisms.

Comparison of BiFC Analysis with Alternative Visualization Methods

Several methods have been developed to study protein interactions in living cells. One of the most commonly employed methods is FRET analysis (42, 59, 61, 68, 72, 102, 110). FRET analysis is based on the use of two fluorophores, either chemically linked or genetically fused to two proteins whose interaction is to be examined. Compared to the BiFC assay, FRET analysis generally requires higher levels of protein expression to detect energy transfer. Also, structural information, or a great deal of luck in the case of proteins of moderate to large size, is required to place the two fluorophores within 100 Å of each other. This is the maximum distance over which significant energy transfer between fluorescent

proteins can be detected. The fraction of proteins that form complexes must also be high enough to produce a sufficient change in the donor and acceptor fluorescence intensities. To exclude alternative interpretations of the results, numerous controls must be performed and the fluorescence intensities must be measured with high quantitative accuracy. Despite these limitations, FRET has been successfully used for the analysis of many protein interactions in living cells. A great advantage of FRET over BiFC analysis is that the complexes are in principle at equilibrium, allowing real-time detection of complex formation and dissociation.

Several characteristics of the BiFC assay make it valuable for many studies of protein interactions. First, it enables direct visualization of protein interactions and does not depend on detection of secondary effects. Second, the interactions can be visualized in living cells, eliminating potential artifacts associated with cell lysis or fixation. Third, the proteins are expressed in their normal cellular context, ideally at levels comparable to their endogenous counterparts. Thus, they are predicted to reflect the properties of the corresponding native proteins, including the effects of any posttranslational modifications. Fourth, the BiFC assay does not require complex formation by a large fraction of the proteins but can detect interactions between subpopulations of each protein. Fifth, multicolor BiFC analysis allows simultaneous visualization of multiple protein complexes in the same cell and enables analysis of the competition between alternative interaction partners for complex formation with a shared subunit. Finally, BiFC analysis does not require specialized equipment, apart from an inverted fluorescence microscope equipped with objectives that allow imaging of fluorescence in cells. The direct detection of bimolecular complex fluorescence requires no postacquisition image processing for interpretation of the data. In sum, BiFC is a powerful tool for cell biologists seeking to understand protein interactions in intact cells.

DESIGN OF BiFC EXPERIMENTS

BiFC analysis is based on enhancement of the association between fluorescent protein fragments by fusion of the fragments to proteins that interact with each other. This will only occur under some conditions. Thus, experiments that make use of the BiFC assay must be designed to take into account parameters that affect the association of the fluorescent protein fragments.

Choice of Fluorescent Protein Fragments

We have identified several combinations of fluorescent protein fragments that can be used for bimolecular fluorescence complementation (44, 45). The combinations of fluorescent protein fragments recommended for BiFC analysis are listed in **Table 2**. For most purposes, fragments of YFP truncated at residue 155 (YN155, N-terminal residues 1–154 and YC155, C-terminal residues 155–238) are recommended, as they produce relatively bright fluorescence signals in complexes formed by many interaction partners but produce low fluorescence when fused to proteins that do not interact with each other under appropriate conditions (see below). Fragments of YFP truncated at residue 173 (YN173, N-terminal residues 1–172 and YC173, C-terminal residues 172–238) as well as fragments of other fluorescent proteins can also be used (45). Fragments of the Venus fluorescent protein often produce brighter fluorescence in BiFC analysis (90, 101). However, these fragments can also produce a higher level of fluorescence when fused to proteins that do not normally interact with each other. Homologous fragments of related fluorescent proteins can also be used in BiFC analysis (48), although their properties have not been characterized in similar detail.

Conditional Association of Fluorescent Protein Fragments

The interaction between the proteins fused to the fluorescent protein fragments must

Table 2 Combinations of fluorescent protein fragments recommended for BiFC analysis

Fusions ^a	Purpose	Excitation filter(s)	Emission filter(s)
A-YN155 B-YC155	A-B interaction	500/20 nm	535/30 nm
A-YN173 B-YC173	A-B interaction	500/20 nm	535/30 nm
A-CN155 B-CC155	A-B interaction	436/10 nm	470/30 nm
A-YN155 B-CN155 Z-CC155	Concurrent visualization of A and B interaction with Z	500/20 nm and 436/10 nm	535/30 nm and 470/30 nm

^aYN155 corresponds to residues 1–154 of EYFP. YC155 corresponds to residues 155–238 of EYFP. YN173 corresponds to residues 1–172 of EYFP. YC173 corresponds to residues 173–238 of EYFP. CN155 corresponds to residues 1–154 of ECFP. CC155 corresponds to residues 155–238 of ECFP.

produce a sufficiently large increase in the efficiency of association between the fluorescent protein fragments to be detectable under the experimental conditions to be used. The association between the fluorescent protein fragments is thought to depend on their local concentrations. Many fluorescent protein fragments can associate with each other independently when expressed at sufficiently high concentrations (13). It is therefore generally advantageous to express the fusion proteins at the lowest levels that permit detection of fluorescence complementation. Ideally, the fusion proteins should be expressed at the same levels as their endogenous counterparts. The tendency of the fluorescent protein fragments to associate is also often reduced when they are fused to proteins that do not associate with each other. It is essential to test the effects of mutations that are predicted to reduce or eliminate the interaction on fluorescence complementation.

Steric Constraints to the Association of the Fluorescent Protein Fragments

The association of the fluorescent protein fragments does not require that the interaction partners position the fragments in the correct relative orientation for association. However, the fragments of the fluorescent proteins must have sufficient freedom of mo-

tion in the complex to allow them to collide with each other sufficiently frequently to facilitate bimolecular fluorescent complex formation. It is generally not possible to predict the arrangement of the fluorescent protein fragments that will produce maximal signal. Fusion proteins that produce optimal signal must therefore be identified by empirical testing of several combinations of fusion proteins. For true interaction partners, it is almost always possible to find a combination of fusion proteins that produces a detectable signal. Unless it is known that fusions to one end of the protein are likely to be nonfunctional or that topological constraints are likely to preclude the association between the fragments in some fusions, it is recommended that fusions to both the N- and C-terminal ends of the proteins under investigation be tested. Schematic diagrams of the different permutations of fusion proteins that can be used for BiFC analysis are shown in **Figure 3**. The fluorescent protein fragments should be fused to the interaction partners using flexible linker sequences to allow maximal mobility of the fragments after complex formation.

Detection of Transient and Weak Complexes

Because BiFC analysis is based on the association between fluorescent protein fragments, and this association is likely to

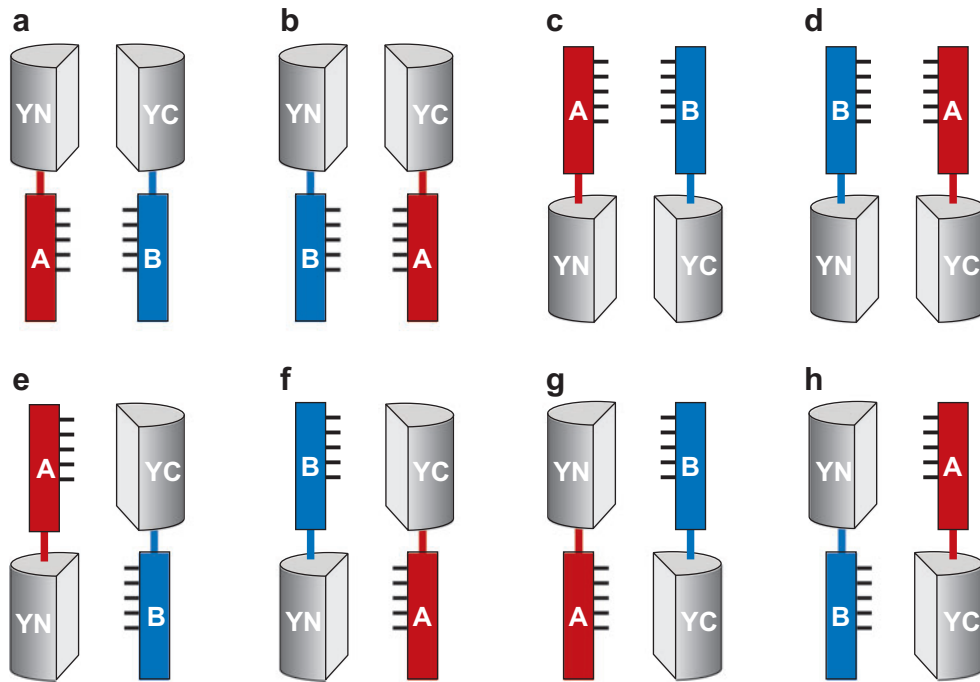

Figure 3

Multiple combinations of fusion proteins should be tested for bimolecular fluorescence complementation. N- and C-terminal fusions can be used to test eight distinct combinations (*a–h*).

stabilize interactions between many proteins (see below), it is possible to detect transient and weak interactions using BiFC analysis. The interaction partners do not need to form a complex with a long half-life because transient interactions can be trapped by the association of the fluorescent protein fragments. It is also not necessary for a large proportion of the interaction partners to associate with each other because the fragments that do not form a complex are invisible in the assay. The high sensitivity of BiFC analysis requires many controls to demonstrate that signal detected in this assay reflects a specific protein interaction.

Controls

To establish whether fluorescence observed in the BiFC assay reflects a specific protein interaction, it is essential to include negative controls in each experiment. The validity of results from BiFC analysis must be confirmed by

examining fluorescence complementation by fusion proteins in which the interaction interface has been mutated (36, 44, 45). The mutant protein should be fused to the fluorescent protein fragments in a manner identical to the wild-type protein. The level of expression and the localization of the mutant protein should be compared with those of the wild-type protein by Western blot and indirect immunofluorescence analyses.

INTERPRETATION OF BiFC EXPERIMENTS

Effects of Fusions on Protein Functions

The potential effects of the fluorescent protein fragment fusions on the functions of the proteins of interest should be tested using assays that measure all known functions of the proteins. Ideally, these functions should be

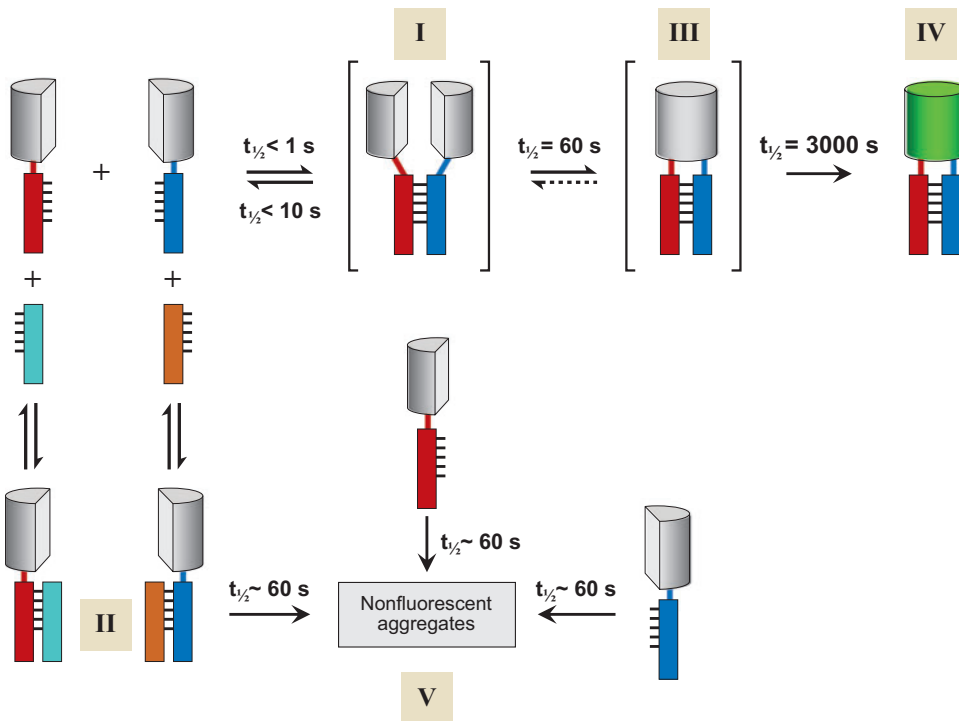

Figure 4

Pathway for formation of bimolecular fluorescent complexes. The pathway for fluorescent complex formation has been deduced based on *in vitro* studies of the dynamics of bimolecular fluorescence complementation using purified proteins (44). See the text for a description of the steps in this pathway.

measured under the same conditions used to visualize the protein interactions. It is particularly important to examine potential consequences of the stabilization of protein interactions by association of the fluorescent protein fragments.

Dynamics of Bimolecular Fluorescent Complexes

The dynamics of BiFC complexes have been investigated *in vitro* to elucidate the pathway for fluorescent complex formation (Figure 4) (44). The initial association between the fusion proteins (Figure 4, complex I) is mediated by the interaction partners. Results from competition studies in which proteins lacking fluorescent protein fragment fusions were added to the mixture of fusion proteins indicate that the initial association between the

fusion proteins can be displaced to form complexes containing only one fluorescent protein fragment (Figure 4, complexes II). The efficiency of this competition decreases with a half-time of 1 min after mixing of the fusion proteins, suggesting that the complex isomerizes to form an irreversible association between the fusion proteins (Figure 4, complex III). The increase in fluorescence displays sigmoidal kinetics, consistent with an initial lag corresponding to the time required for association of the fluorescent protein fragments, followed by maturation with a half-time of 50 min to produce the fluorescent BiFC complex (Figure 4, complex IV). The fluorophores of all GFP variants are formed via autocatalytic reactions after folding of the polypeptide, a process known as maturation. The rate of maturation of BiFC complex fluorescence was equivalent to the rate of

maturation of the corresponding intact fluorescent protein.

The fluorescent protein fragments that do not associate with a complementary fragment become trapped in a form that is not competent for subsequent association (Figure 4, complex V). This loss of competence for association is likely to be significant for the specificity of BiFC analysis because it results in a kinetic barrier to the association of fluorescent protein fragments that are fused to proteins that do not normally interact with each other. This model based on *in vitro* studies can account for many of the results observed in cells, including the requirement for a specific interaction between the proteins fused to the fluorescent protein fragments for efficient BiFC complex formation.

Fragments of a different GFP derivative conjugated to nucleic acid interaction partners can produce fluorescence with more than 100-fold-faster kinetics *in vitro* (22) than the fusion proteins originally investigated (44). These results may reflect chemical maturation of the fluorescent protein fragments during expression or purification, possibly assisted by the intein cleavage or biotin conjugation reactions. The fluorescence intensity of BiFC complexes produced by these fragments was reduced under conditions predicted to destabilize the nucleic acid interaction (22). These results are consistent with rapid fluorescent complex formation and dissociation by the fluorescent protein fragments, suggesting that BiFC analysis can be used for nearly real-time visualization of some interactions under the *in vitro* conditions used in these experiments.

The differences in the dynamics of BiFC complex fluorescence in these experiments may reflect differences in the experimental conditions, the fluorescent protein fragments used, or the interactions studied. Because these studies were performed *in vitro*, a significant question is whether BiFC complexes exhibit rapid fluorescent complex formation and dissociation in cells. Several studies of interactions between various proteins have re-

ported rapid changes in fluorescence intensity observed in BiFC analysis in response to stimuli predicted to affect the interactions (38, 66, 98). However, it is difficult to exclude the possibility that changes in the cellular environment or variations in protein turnover affect the fluorescence intensity measured in these experiments. Further studies of the dynamics of BiFC complexes in living cells are needed to address this issue.

The Efficiency of Bimolecular Fluorescence Complementation

The fluorescence intensity produced by bimolecular fluorescence complementation varies widely for interactions between different partners and for different fusions to the same partners. The fluorescence intensity produced by BiFC complexes in living cells is generally less than 10% of that produced by expression of an intact fluorescent protein. Nevertheless, because autofluorescence in the visible range is extremely low in most cells, the signal from bimolecular fluorescence complementation is often orders of magnitude higher than background fluorescence.

The efficiency of fluorescence complementation is defined as the fluorescence intensity produced by bimolecular fluorescent complex formation when a specific level of fusion proteins is expressed in the cell. The efficiencies of bimolecular fluorescence complementation produced by structurally unrelated proteins cannot be used to determine the efficiencies of complex formation because many factors unrelated to the efficiency of complex formation influence the efficiency of bimolecular fluorescence complementation. Nevertheless, in situations in which all these factors are predicted to be identical, such as in the case of wild-type and mutated interactions partners, differences in the efficiencies of bimolecular fluorescence complementation can provide information about the relative efficiencies of complex formation. Thus, the effects of single amino acid substitutions that do not alter the level of protein expression or

its localization can be examined by comparing the efficiencies of fluorescence complementation by the wild-type and mutated proteins (44, 45).

To compare the relative efficiencies of fluorescence complementation between different partners, it is necessary to include internal controls in the experiments to correct for differences in the efficiencies of transfection and the levels of protein expression in individual cells (Figure 5). For this purpose, cells can be co-transfected with plasmids encoding the two fusion proteins and with a plasmid encoding a full-length fluorescent protein with distinct spectral characteristics (e.g., cyan fluorescent protein, CFP). The fluorescence intensities derived from both bimolecular fluorescence complementation (e.g., YN-YC) and the internal control (e.g., CFP) are measured in individual cells. The ratio of YN-YC to CFP fluorescence is a measure of the efficiency of bimolecular fluorescence complementation. The relative ratios for different combinations of fusion proteins reflect the relative efficiencies of complex formation.

APPLICATIONS OF BiFC ANALYSIS

The BiFC assay has been used for visualization of interactions among a variety of proteins in different subcellular locations and in several organisms. These studies have demonstrated the broad applicability of the BiFC assay, which is likely suitable for studies in any aerobically grown cell and organism that can be genetically modified to express the fusion proteins.

Subcellular Localization of Protein Complexes

Identification of the subcellular localization of protein complexes is perhaps the most general application of BiFC analysis beyond the simple determination whether two proteins can interact in living cells. BiFC complexes

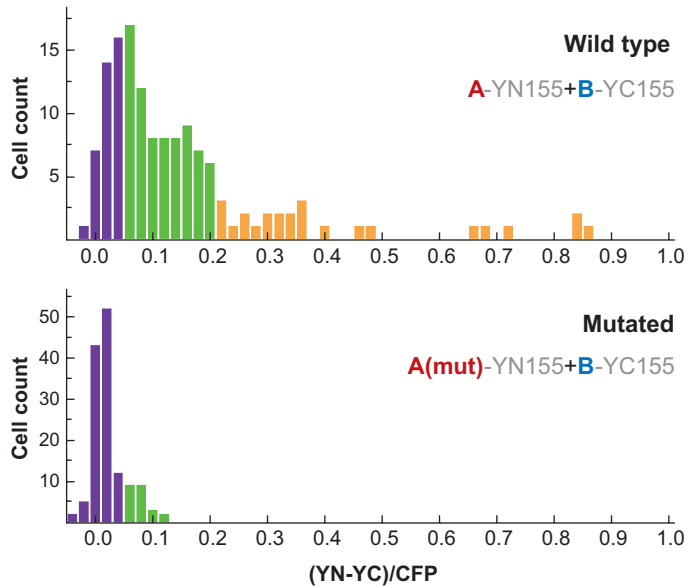

Figure 5

The effects of mutations that prevent the association of the interaction partners should be tested to determine the specificity of the bimolecular fluorescence complementation (data adapted from Reference 44). Plasmids encoding a wild-type interaction partner, B, and either the wild-type (*upper panel*) or mutated (*lower panel*) forms of an interaction partner, A, fused to the fluorescent protein fragments were transfected into cells together with an internal reference encoding CFP. The fluorescence intensities produced by bimolecular fluorescence complementation (YN-YC) and the internal reference (CFP) were measured in individual cells. The distribution of ratios between the fluorescence intensities in individual cells is plotted in each histogram.

have been visualized in all major subcellular compartments of mammalian cells, including numerous subnuclear structures (23, 30, 31, 36, 37, 44, 45, 49, 52, 83, 91, 99, 126), lysosomes (30), the plasma membrane (34, 38, 47, 60, 64, 71, 93, 124), lamellipodia (21), Golgi (76), the endoplasmic reticulum (4, 7, 77, 78, 79, 107), mitochondria (108), viral particles (10), and lipid droplets (35). It has provided special insight into the regulation of complex localization including nuclear translocation (29, 39, 44, 63, 75, 109). These results confirm that BiFC complexes can form in the varied environments of different cellular compartments. In these studies, it is essential to determine if the association of fluorescent protein fragments affects the localization of the protein complex.

One strategy to accomplish this is to determine the localization of one interaction partner in the presence of an overexpressed partner lacking the fluorescent protein fragment (36). In addition to numerous interactions involving soluble proteins, BiFC analysis has also been used to study interactions involving integral membrane proteins (21, 64), demonstrating that the topological constraints of these proteins do not prevent the use of BiFC analysis.

Signal Transduction Networks

Many proteins interact with a large number of different partners. The sum of these interactions produces a complex network of connections where signals impinging on a single node (protein) can be propagated throughout the network. Visualization of individual interactions within this network can provide insight into the relationships between a specific interaction within the network and the signals that modulate its localization and efficiency. Numerous interactions involving both diffusible components of such networks (2, 19, 20, 28, 41, 46, 95, 98, 118) and membrane receptors (16, 21, 64) have been visualized using BiFC analysis. Interactions between cytoplasmic and nuclear signal transduction components (3, 119) have enabled tracking of signal transduction between different cellular compartments.

Protein Interactions Associated with Cytokinesis

Interactions that occur in a cell cycle-regulated manner are particularly interesting and challenging subjects for imaging studies. This is because the complexes are transient, placing special requirements on the efficiency and rate of complex detection. Faithful representation of the cell cycle-regulated formation of these complexes also requires that the methods used for imaging them do not distort the temporal regulation of complex for-

mation and dissociation or degradation. BiFC analysis has been used to visualize the complex formed by Grr1 and Hof1 (8). Grr1 interacts with Hof1 specifically in the bud neck between the mother and daughter cells during the G2-M stage of the cell cycle. This association results in degradation of Hof1, which is required for efficient contraction of the actin ring closing the bud neck and cytokinesis. Interactions between the p0071 catenin family member with the RhoA small GTPase and the Ect guanine nucleotide exchange factor have also been visualized using BiFC analysis at the midbody, a structure located at the site of cytokinesis during telophase in mammalian cells (54). These results demonstrate the detection of spatially and temporally restricted complex formation by BiFC analysis.

Interactions on Scaffolds

Many proteins can be brought in proximity to each other by binding to the same interaction partner that can serve as a scaffold for the assembly of multiprotein complexes. Such scaffolds are not limited to proteins but include nucleic acids, carbohydrates, and other cellular macromolecules. Simultaneous binding by two proteins in the vicinity of each other on the same scaffold can be detected by BiFC analysis. This principle has been used to detect RNA binding by fusing the fragments of the fluorescent protein to two RNA binding proteins (90). It has also been used to visualize RNA export complexes in the nucleus and to measure the turnover rate of such complexes (99). By designing fusion proteins that can bind to a single type of RNA molecule, this approach has been used to track RNA inside living cells (80). Similar fusion proteins with a designed binding specificity for DNA display fluorescence complementation *in vitro* upon binding to a specific DNA oligonucleotide (105). One concern regarding this general strategy is that the fluorescent complex assembled on the scaffold might remain fluorescent following dissociation from the scaffold.

Visualization of Interactions in Living Organisms

The BiFC assay has been applied to studies in a variety of unicellular and multicellular organisms. Many interactions have been visualized in *E. coli* (6, 33, 67, 73), *Agrobacterium tumefaciens* (15, 111), and *Bacillus subtilis* (75, 103). Among fungi, BiFC analysis has been extensively used in *Saccharomyces cerevisiae* (Baker's yeast) (8, 53, 82), and also in *Acremonium chrysogenum* (43), *Aspergillus nidulans* (9), and *Magnaporthe grisea* (125). Among higher eukaryotic organisms, BiFC analysis has been used to visualize numerous interactions in many plant species (1, 5, 11, 12, 14, 17, 18, 24, 25, 40, 51, 57, 58, 62, 65, 69, 70, 81, 86, 88, 92, 100, 106, 112, 116, 117, 122, 123). Virtually all these studies have been performed by transient expression using heterologous expression vectors, suggesting that the expression of the fusion proteins is unlikely to reflect their normal tissue-specific patterns. BiFC analysis has also been used to visualize interactions between *Caenorhabditis elegans* proteins (75).

Interaction Screens Using BiFC Analysis

The BiFC assay can be used as a screening tool to identify potential interaction partners as well as modifiers of known interactions (26, 93). The challenge of implementing a screen for interaction partners is that the levels of expression of different fusion proteins in a library are likely to vary over a large range and may not reflect the levels of expression of the corresponding endogenous proteins. Thus, differences in BiFC signal are likely affected by a variety of factors unrelated to the efficiency of the protein interaction. Nevertheless, several novel interaction partners have been identified using this strategy (26, 93).

BiFC analysis can also be used to screen for small-molecule modulators (66). There are numerous mechanisms whereby small molecules could influence the fluorescence in-

tensity produced in BiFC assays. Nevertheless, because many of these mechanisms could also influence the endogenous proteins, this provides a useful strategy for the identification of small molecules that alter specific protein complexes in living cells. Comparison of the effects of specific small molecules on a panel of BiFC complexes can provide an indication of the degree of specificity of their effects.

SIMULTANEOUS VISUALIZATION OF MULTIPLE PROTEIN INTERACTIONS

Many proteins have a large number of potential interaction partners. Often these interactions are mutually exclusive, such that only one protein can interact with a particular protein molecule at any one time. This results in competition for shared interaction partners in cells that express several alternative partners. The multicolor BiFC assay enables visualization of interactions between multiple combinations of proteins in the same cell (45). This assay is based on the formation of fluorescent complexes with different spectra through the association of fragments of different fluorescent proteins fused to alternative interaction partners (Figure 6). The multicolor BiFC assay enables comparison of the subcellular distributions of several protein complexes in the same cell and allows analysis of the competition between mutually exclusive interaction partners for binding to a common partner.

Comparison of the Distributions of Multiple Protein Complexes in the Same Cell

Complexes formed by a protein with different interaction partners often have different functions. These functional differences can be reflected in differences between the subcellular distributions of the protein complexes. The subcellular distributions of different protein complexes can be compared by identifying a marker that has the same distribution as one or the other complex and comparing the distribution of the second complex with that of the

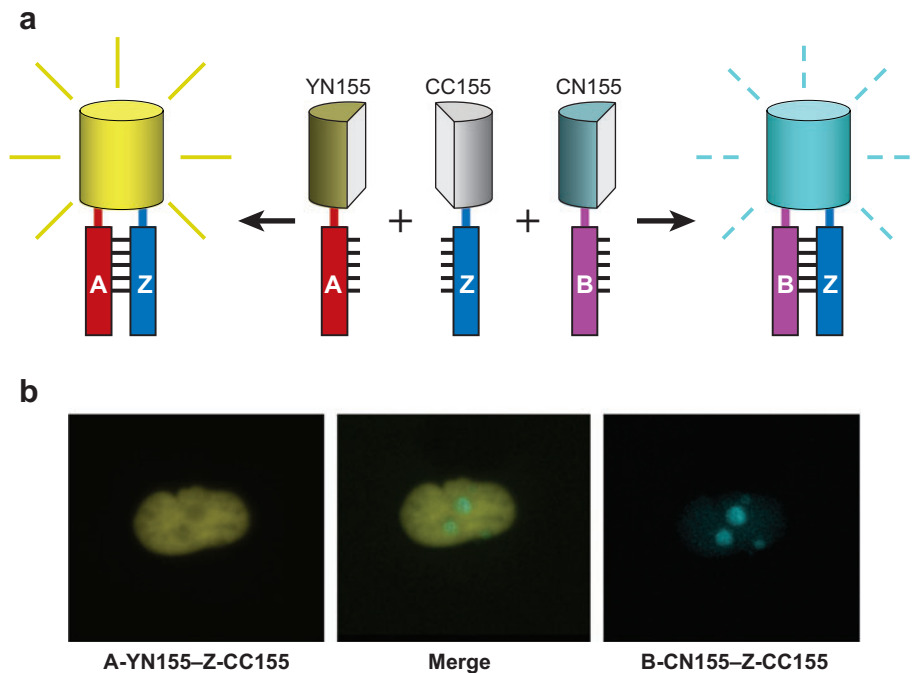

Figure 6

Concurrent visualization of multiple protein complexes using multicolor fluorescence complementation analysis. (a) Two alternative interaction partners, A and B, are fused to fragments of different fluorescent proteins (YN155 and CN155, respectively). These fusions are coexpressed in cells, with a shared interaction partner, Z, fused to a complementary fragment (CC155). Complexes formed by A-YN155 and Z-CC155 can be distinguished from complexes formed by B-CN155 and Z-CC155 because of differences between their fluorescence spectra. (b) Schematic representation of the visualization of multiple protein complexes in the same cell (A-YN155-Z-CC155, cytoplasmic and perinuclear; B-CN155-Z-CC155, nuclear and perinuclear).

marker in a different cell. However, it is often difficult to find markers that have distributions identical to specific protein complexes. It is therefore desirable to compare the distributions of different protein complexes in the same cell. The multicolor BiFC assay enables comparison of the distributions of two or more protein complexes in the same cell.

Comparison of the Efficiencies of Complex Formation Between Alternative Interaction Partners

The multicolor BiFC assay can also be used to compare the efficiencies of complex formation by different proteins with a shared interaction partner (36, 45). Quantitative analysis of the

relative efficiencies of complex formation using multicolor BiFC analysis is valid only in cases in which the efficiencies of association between the fluorescent protein fragments are identical for both complexes being studied. This is generally true only in the case of interactions between structurally related proteins to which the fragments have been fused in an identical manner. To determine if the identities of the fluorescent protein fragments fused to each interaction partner affect the relative efficiencies of complex formation, it is essential to exchange the fragments between the fusion proteins and to repeat the experiments using the reciprocally exchanged fusions. It is also essential to develop a calibration standard that allows determination of the relative

fluorescence intensities produced by the spectrally distinct complexes when fused to interaction partners that form complexes with the same efficiency. This calibration standard can be generated by fusing the fluorescent protein fragments to the same interaction partners (36, 45).

The relative efficiencies of complex formation in the multicolor BiFC assay are affected by the levels of protein expression, which must be considered when interpreting the results of such experiments. The efficiencies of complex formation measured in the multicolor BiFC assay reflect numerous factors in addition to intrinsic binding affinity. These factors include the subcellular distributions of the interaction partners and the effects of any cellular factors that can facilitate or hinder an interaction, including posttranslational modifications and the network of alternative partners. Moreover, in many cases, BiFC complex formation is irreversible after association of the fluorescent protein fragments. Thus, changes in cellular conditions after the time of complex formation may not be reflected in the relative efficiencies of complex formation. Nevertheless, because the rate of association of the fluorescent protein fragments is likely to be slower than the rate of exchange between many alternative interaction partners, the interactions between the alternative fusion partners will likely reach equilibrium prior to complex fixation by association of the fluorescent protein fragments.

Design of Multicolor BiFC Experiments

Multicolor BiFC analysis requires fusion of the alternative interaction partners to fragments of fluorescent proteins that produce complexes with different spectra (**Table 2**). Because the two complexes can be imaged sequentially, spectral overlap is generally not a problem since different excitation and emission wavelengths can be used to visualize the complexes. Although this is not strictly simultaneous, alternate imaging of the two com-

plexes can be performed to confirm that the delay of a few seconds between acquisition of the images does not allow time for relocalization of either complex. Ideally, the two complexes should have fluorescence intensities of the same order of magnitude in order to avoid the possibility that differences in the signal-to-background ratio produce the appearance of differences in distribution. However, such background signal and any cross-talk between the two fluorophores can be corrected for by imaging cells that express only one combination of fusion proteins. The fusion proteins should be expressed at levels comparable to the endogenous proteins to establish that the distributions are not affected by the levels of expression of the proteins. As in the analysis of a single protein interaction using BiFC analysis, it is critical to determine if mutations that eliminate each interaction individually also eliminate the corresponding BiFC signal.

Applications of Multicolor BiFC Analysis

The multicolor BiFC assay has been applied to analysis of the relative efficiencies of complex formation between several families of nuclear transcription regulatory proteins (36, 45) as well as the large family of cytoplasmic small G protein subunits (27, 71). The results of these experiments have shown that the efficiencies of interactions with proteins that are closely related in both sequence and structure can differ substantially in the cell. The reasons for these differences are generally unknown.

SUMMARY AND FUTURE PROSPECTS

The BiFC assay has become a standard approach for the visualization of protein interactions. When appropriate controls are performed, BiFC analysis has proved to be a reliable tool for the detection of protein interactions in living cells. False positives can be avoided by ensuring that the fusion proteins are expressed at levels comparable to the

corresponding endogenous proteins, and by performing appropriate controls to determine if mutations that eliminate an interaction also eliminate the fluorescence signal. Anecdotal evidence suggests that false negatives are occasionally encountered. However, these can often be corrected by more comprehensive testing of multiple combinations of fusions to the same interaction partners.

The BiFC assay is finding new applications at an accelerating rate and it is being adapted for new purposes on the basis of the general principle that the association of the fluorescent protein fragments can be enhanced when they are brought in proximity to each other and provided the dynamic flexibility necessary for them to collide with each other. Some of the limitations of the BiFC assay identified in the original description (44) of this approach remain to be solved. The association between the fluorescent protein fragments stabilizes the association between the interaction partners. This stabilization can result in essentially irreversible complex formation and can potentially alter the function or activity of the complex. A better understanding of the folding and dynamics of the bimolecular complex formed by the fluorescent protein fragments could help provide strategies to solve this problem.

The fluorescent protein fragments also have the capacity to associate with each other to form a fluorescent complex even if the proteins to which they are fused do not normally interact with each other. This propensity varies depending on the proteins to which the fragments are fused, and the intrinsic tendency of the fragments alone to associate is generally reduced by fusion of the fragments to proteins that do not interact with each other. Nevertheless, identification of fragments of fluorescent proteins with a reduced tendency to associate with each other spontaneously, but an undiminished ability to associate when present in the same macromolecular complex, would be of significant benefit. Mutational engineering of full-length GFP family members has produced proteins with an astounding range of photophysical and photochemical characteristics. It is therefore virtually guaranteed that future efforts to engineer fragments of fluorescent proteins for BiFC analysis will produce improved versions. It is also likely that fragments that are optimal for a particular purpose will not be ideal for all purposes. It is therefore important to perform comparative analysis of BiFC assays using different fluorescent protein fragments to evaluate their relative merits.

DISCLOSURE STATEMENT

The author is not aware of any biases that might be perceived as affecting the objectivity of this review.

ACKNOWLEDGMENTS

I thank Changdeng Hu for his contributions to the implementation of the BiFC assay and members of the Kerppola laboratory for extending the BiFC assay to new applications.

LITERATURE CITED

1. Abe M, Kobayashi Y, Yamamoto S, Daimon Y, Yamaguchi A, et al. 2005. FD, a bZIP protein mediating signals from the floral pathway integrator FT at the shoot apex. *Science* 309:1052–56
2. Adolph D, Flach N, Mueller K, Ostareck DH, Ostareck-Lederer A. 2007. Deciphering the cross talk between hnRNP K and c-Src: The c-Src activation domain in hnRNP K is distinct from a second interaction site. *Mol. Cell. Biol.* 27:1758–70

3. Ahmed KM, Dong SZ, Fan M, Li JJ. 2006. Nuclear factor-kappa B p65 inhibits mitogen-activated protein kinase signaling pathway in radioresistant breast cancer cells. *Mol. Cancer Res.* 4:945-55
4. Anderie I, Schulz I, Schmid A. 2007. Direct interaction between ER membrane-bound PTP1B and its plasma membrane-anchored targets. *Cell. Signal.* 19:582-92
5. Aparicio F, Sanchez-Navarro JA, Pallas V. 2006. In vitro and in vivo mapping of the Prunus necrotic ringspot virus coat protein C-terminal dimerization domain by bimolecular fluorescence complementation. *J. Gen. Virol.* 87:1745-50
6. Atmakuri K, Ding ZY, Christie PJ. 2003. VirE2, a type IV secretion substrate, interacts with the VirD4 transfer protein at cell poles of *Agrobacterium tumefaciens*. *Mol. Microbiol.* 49:1699-713
7. BelAiba RS, Djordjevic T, Petry A, Diemer K, Bonello S, et al. 2007. NOX5 variants are functionally active in endothelial cells. *Free Radic. Biol. Med.* 42:446-59
8. Blondel M, Bach S, Bamps S, Dobbelaere J, Wiget P, et al. 2005. Degradation of Hof1 by SCFGrr1 is important for actomyosin contraction during cytokinesis in yeast. *EMBO J.* 24:1440-52
9. Blumenstein A, Vienken K, Tasler R, Purschwitz J, Veith D, et al. 2005. The *Aspergillus nidulans* phytochrome FphA represses sexual development in red light. *Curr. Biol.* 15:1833-38
10. Boyko V, Leavitt M, Gorelick R, Fu W, Nikolaitchik O, et al. 2006. Coassembly and complementation of Gag proteins from HIV-1 and HIV-2, two distinct human pathogens. *Mol. Cell* 23:281-87
11. Bracha-Drori K, Shichrur K, Katz A, Oliva M, Angelovici R, et al. 2004. Detection of protein-protein interactions in plants using bimolecular fluorescence complementation. *Plant J.* 40:419-27
12. Burch-Smith TM, Schiff M, Caplan JL, Tsao J, Czymmek K, Dinesh-Kumar SP. 2007. A novel role for the TIR domain in association with pathogen-derived elicitors. *PLoS Biol.* 5:e68
13. Cabantous S, Terwilliger TC, Waldo GS. 2005. Protein tagging and detection with engineered self-assembling fragments of green fluorescent protein. *Nat. Biotechnol.* 23:102-7
14. Canto T, Uhrig JF, Swanson M, Wright KM, MacFarlane SA. 2006. Translocation of Tomato bushy stunt virus P19 protein into the nucleus by ALY proteins compromises its silencing suppressor activity. *J. Virol.* 80:9064-72
15. Cascales E, Atmakuri K, Liu Z, Binns AN, Christie PJ. 2005. *Agrobacterium tumefaciens* oncogenic suppressors inhibit T-DNA and VirE2 protein substrate binding to the VirD4 coupling protein. *Mol. Microbiol.* 58:565-79
16. Chen CD, Oh SY, Hinman JD, Abraham CR. 2006. Visualization of APP dimerization and APP-Notch2 heterodimerization in living cells using bimolecular fluorescence complementation. *J. Neurochem.* 97:30-43
17. Chen SB, Tao LZ, Zeng LR, Vega-Sanchez ME, Umemura K, Wang GL. 2006. A highly efficient transient protoplast system for analyzing defence gene expression and protein-protein interactions in rice. *Mol. Plant Pathol.* 7:417-27
18. Citovsky V, Lee LY, Vyas S, Glick E, Chen MH, et al. 2006. Subcellular localization of interacting proteins by bimolecular fluorescence complementation in planta. *J. Mol. Biol.* 362:1120-31
19. Cole KC, McLaughlin HW, Johnson DI. 2007. Use of bimolecular fluorescence complementation to study in vivo interactions between Cdc42p and Rdi1p of *Saccharomyces cerevisiae*. *Eukaryot. Cell* 6:378-87

20. de Bie P, de Sluis B, Burstein E, Duran KJ, Berger R, et al. 2006. Characterization of COMMD protein-protein interactions in NF-kappa B signalling. *Biochem. J.* 398:63-71
21. de Virgilio M, Kiosses WB, Shattil SJ. 2004. Proximal, selective, and dynamic interactions between integrin alpha II beta 3 and protein tyrosine kinases in living cells. *J. Cell Biol.* 165:305-11
22. Demidov VV, Dokholyan NV, Witte-Hoffmann C, Chalasani P, Yiu HW, et al. 2006. Fast complementation of split fluorescent protein triggered by DNA hybridization. *Proc. Natl. Acad. Sci. USA* 103:2052-56
23. Deppmann CD, Thornton TM, Utama FE, Taparowsky EJ. 2003. Phosphorylation of BATF regulates DNA binding: a novel mechanism for AP-1 (activator protein-1) regulation. *Biochem. J.* 374:423-31
24. Diaz I, Martinez M, Isabel-LaMoneda I, Rubio-Somoza I, Carbonero P. 2005. The DOF protein, SAD, interacts with GAMYB in plant nuclei and activates transcription of endosperm-specific genes during barley seed development. *Plant J.* 42:652-62
25. Ding YH, Liu NY, Tang ZS, Liu J, Yang WC. 2006. *Arabidopsis* GLUTAMINE-RICH PROTEIN23 is essential for early embryogenesis and encodes a novel nuclear PPR motif protein that interacts with RNA polymerase II subunit III. *Plant Cell* 18:815-30
26. Ding ZY, Liang JY, Lu YL, Yu QH, Zhou SY, et al. 2006. A retrovirus-based protein complementation assay screen reveals functional AKT1-binding partners. *Proc. Natl. Acad. Sci. USA* 103:15014-19
27. Dupre DJ, Robitaille M, Ethier N, Villeneuve LR, Mamarbachi AM, Hebert TE. 2006. Seven transmembrane receptor core signaling complexes are assembled prior to plasma membrane trafficking. *J. Biol. Chem.* 281:34561-73
28. Dupre DJ, Robitaille M, Richer M, Ethier N, Mamarbachi AM, Hebert TE. 2007. Dopamine receptor-interacting protein 78 acts as a molecular chaperone for G gamma subunits before assembly with G beta. *J. Biol. Chem.* 282:13703-15
29. Fan M, Ahmed KM, Coleman MC, Spitz DR, Li JJ. 2007. Nuclear factor-kappa B and manganese superoxide dismutase mediate adaptive radioresistance in low-dose irradiated mouse skin epithelial cells. *Cancer Res.* 67:3220-28
30. Fang DY, Kerppola TK. 2004. Ubiquitin-mediated fluorescence complementation reveals that Jun ubiquitinated by Itch/AIP4 is localized to lysosomes. *Proc. Natl. Acad. Sci. USA* 101:14782-87
31. Farina A, Hattori M, Qin J, Nakatani Y, Minato N, Ozato K. 2004. Bromodomain protein Brd4 binds to GTPase-activating SPA-1, modulating its activity and subcellular localization. *Mol. Cell. Biol.* 24:9059-69
32. Galarneau A, Primeau M, Trudeau LE, Michnick SW. 2002. Beta-lactamase protein fragment complementation assays as in vivo and in vitro sensors of protein protein interactions. *Nat. Biotechnol.* 20:619-22
33. Ghosh I, Hamilton AD, Regan L. 2000. Antiparallel leucine zipper-directed protein re-assembly: application to the green fluorescent protein. *J. Am. Chem. Soc.* 122:5658-59
34. Giese B, Roderburg C, Sommerauer M, Wortmann SB, Metz S, et al. 2005. Dimerization of the cytokine receptors gp130 and LIFR analysed in single cells. *J. Cell Sci.* 118:5129-40
35. Granneman JG, Moore HPH, Granneman RL, Greenberg AS, Obin MS, Zhu ZX. 2007. Analysis of lipolytic protein trafficking and interactions in adipocytes. *J. Biol. Chem.* 282:5726-35
36. Grinberg AV, Hu CD, Kerppola TK. 2004. Visualization of Myc/Max/Mad family dimers and the competition for dimerization in living cells. *Mol. Cell. Biol.* 24:4294-308

37. Guo HX, Cun W, Liu LD, Dong SZ, Wang LC, et al. 2006. Protein encoded by HSV-1 stimulation-related gene 1 (HSRG1) interacts with and inhibits SV40 large T antigen. *Cell Prolif.* 39:507-18
38. Guo YJ, Rebecchi M, Scarlata S. 2005. Phospholipase C beta(2) binds to and inhibits phospholipase C delta(1). *J. Biol. Chem.* 280:1438-47
39. Gwozdz T, Dutko-Gwozdz J, Nieva C, Betanska K, Orłowski M, et al. 2007. EcR and Usp, components of the ecdysteroid nuclear receptor complex, exhibit differential distribution of molecular determinants directing subcellular trafficking. *Cell. Signal.* 19:490-503
40. Hackbusch J, Richter K, Muller J, Salamini F, Uhrig JF. 2005. A central role of *Arabidopsis thaliana* ovate family proteins in networking and subcellular localization of 3-aa loop extension homeodomain proteins. *Proc. Natl. Acad. Sci. USA* 102:4908-12
41. Hausser A, Link G, Hoene M, Russo C, Selchow O, Pfizenmaier K. 2006. Phospho-specific binding of 14-3-3 proteins to phosphatidylinositol 4-kinase III beta protects from dephosphorylation and stabilizes lipid kinase activity. *J. Cell Sci.* 119:3613-21
42. Hink MA, Borst JW, Visser AJ. 2003. Fluorescence correlation spectroscopy of GFP fusion proteins in living plant cells. *Methods Enzymol.* 361:93-112
43. Hoff B, Kuck U. 2005. Use of bimolecular fluorescence complementation to demonstrate transcription factor interaction in nuclei of living cells from the filamentous fungus *Acremonium chrysogenum*. *Curr. Genet.* 47:132-38
44. Hu CD, Chinenov Y, Kerppola TK. 2002. Visualization of interactions among bZIP and Rel family proteins in living cells using bimolecular fluorescence complementation. *Mol. Cell* 9:789-98
45. Hu CD, Kerppola TK. 2003. Simultaneous visualization of multiple protein interactions in living cells using multicolor fluorescence complementation analysis. *Nat. Biotechnol.* 21:539-45
46. Hynes TR, Mervine SM, Yost EA, Sabo JL, Berlot CH. 2004. Live cell imaging of G(s) and the beta(2)-adrenergic receptor demonstrates that both alpha(s) and beta(1)gamma(7) internalize upon stimulation and exhibit similar trafficking patterns that differ from that of the beta(2)-adrenergic receptor. *J. Biol. Chem.* 279:44101-12
47. Hynes TR, Tang LN, Mervine SM, Sabo JL, Yost EA, et al. 2004. Visualization of G protein beta gamma dimers using bimolecular fluorescence complementation demonstrates roles for both beta and gamma in subcellular targeting. *J. Biol. Chem.* 279:30279-86
48. Jach G, Pesch M, Richter K, Frings S, Uhrig JF. 2006. An improved mRFP1 adds red to bimolecular fluorescence complementation. *Nat. Methods* 3:597-600
49. Jang MK, Mochizuki K, Zhou MS, Jeong HS, Brady JN, Ozato K. 2005. The bromodomain protein Brd4 is a positive regulatory component of P-TEFb and stimulates RNA polymerase II-dependent transcription. *Mol. Cell* 19:523-34
50. Johnsson N, Varshavsky A. 1994. Split ubiquitin as a sensor of protein interactions in vivo. *Proc. Natl. Acad. Sci. USA* 91:10340-44
51. Kaminaka H, Nake C, Epple P, Dittgen J, Schutze K, et al. 2006. bZIP10-LSD1 antagonism modulates basal defense and cell death in *Arabidopsis* following infection. *EMBO J.* 25:4400-11
52. Kanno T, Kanno Y, Siegel RM, Jang MK, Lenardo MJ, Ozato K. 2004. Selective recognition of acetylated histones by bromodomain proteins visualized in living cells. *Mol. Cell* 13:33-43
53. Kass G, Arad G, Rosenbluh J, Gafni Y, Graessmann A, et al. 2006. Permeabilized mammalian cells as an experimental system for nuclear import of geminiviral karyophilic proteins and of synthetic peptides derived from their nuclear localization signal regions. *J. Gen. Virol.* 87:2709-20

54. Keil R, Wolf A, Huttelmaier S, Hatzfeld M. 2007. Beyond regulation of cell adhesion: local control of RhoA at the cleavage furrow by the p0071 catenin. *Cell Cycle* 6:122–27
55. Kerppola TK. 2006. Complementary methods for studies of protein interactions in living cells. *Nat. Methods* 3:969–71
56. Kerppola TK. 2006. Visualization of molecular interactions by fluorescence complementation. *Nat. Rev. Mol. Cell Biol.* 7:449–56
57. Krichevsky A, Gutgarts H, Kozlovsky SV, Tzfira T, Sutton A, et al. 2007. C2H2 zinc finger-SET histone methyltransferase is a plant-specific chromatin modifier. *Dev. Biol.* 303:259–69
58. Lacroix B, Vaidya M, Tzfira T, Citovsky V. 2005. The VirE3 protein of *Agrobacterium* mimics a host cell function required for plant genetic transformation. *EMBO J.* 24:428–37
59. Larson DR, Ma YM, Vogt VM, Webb WW. 2003. Direct measurement of Gag–Gag interaction during retrovirus assembly with FRET and fluorescence correlation spectroscopy. *J. Cell Biol.* 162:1233–44
60. Lee SK, Boyko V, Hu WS. 2007. Capsid is an important determinant for functional complementation of murine leukemia virus and spleen necrosis virus Gag proteins. *Virology* 360:388–97
61. Li HY, Ng EK, Lee SM, Kotaka M, Tsui SK, et al. 2001. Protein-protein interaction of FHL3 with FHL2 and visualization of their interaction by green fluorescent proteins (GFP) two-fusion fluorescence resonance energy transfer (FRET). *J. Cell. Biochem.* 80:293–303
62. Li JX, Krichevsky A, Vaidya M, Tzfira T, Citovsky V. 2005. Uncoupling of the functions of the *Arabidopsis* VIN protein in transient and stable plant genetic transformation by *Agrobacterium*. *Proc. Natl. Acad. Sci. USA* 102:5733–38
63. Liu H, Deng XH, Shyu YJ, Li JJ, Taparowsky EJ, Hu CD. 2006. Mutual regulation of c-Jun and ATF2 by transcriptional activation and subcellular localization. *EMBO J.* 25:1058–69
64. Lopez-Gimenez JF, Canals M, Padiani JD, Milligan G. 2007. The alpha(1b)-adrenoceptor exists as a higher-order oligomer: Effective oligomerization is required for receptor maturation, surface delivery, and function. *Mol. Pharmacol.* 71:1015–29
65. Loyter A, Rosenbluh J, Zakai N, Li JX, Kozlovsky SV, et al. 2005. The plant VirE2 interacting protein 1. A molecular link between the *Agrobacterium* T-complex and the host cell chromatin? *Plant Physiol.* 138:1318–21
66. MacDonald ML, Lamerdin J, Owens S, Keon BH, Bilter GK, et al. 2006. Identifying off-target effects and hidden phenotypes of drugs in human cells. *Nat. Chem. Biol.* 2:329–37
67. Magliery TJ, Wilson CGM, Pan WL, Mishler D, Ghosh I, et al. 2005. Detecting protein-protein interactions with a green fluorescent protein fragment reassembly trap: scope and mechanism. *J. Am. Chem. Soc.* 127:146–57
68. Majoul I, Straub M, Duden R, Hell SW, Soling HD. 2002. Fluorescence resonance energy transfer analysis of protein-protein interactions in single living cells by multifocal multiphoton microscopy. *J. Biotechnol.* 82:267–77
69. Maple J, Aldridge C, Moller SG. 2005. Plastid division is mediated by combinatorial assembly of plastid division proteins. *Plant J.* 43:811–23
70. Marrocco K, Zhou YC, Bury E, Dieterle M, Funk M, et al. 2006. Functional analysis of EID1, an F-box protein involved in phytochrome A-dependent light signal transduction. *Plant J.* 45:423–38

71. Mervine SM, Yost EA, Sabo JL, Hynes TR, Berlot CH. 2006. Analysis of G protein beta gamma dimer formation in live cells using multicolor bimolecular fluorescence complementation demonstrates preferences of beta(1) for particular gamma subunits. *Mol. Pharmacol.* 70:194–205
72. Miyawaki A. 2003. Visualization of the spatial and temporal dynamics of intracellular signaling. *Dev. Cell* 4:295–305
73. Morell M, Espargaro A, Aviles FX, Ventura S. 2007. Detection of transient protein-protein interactions by bimolecular fluorescence complementation: the Abl-SH3 case. *Proteomics* 7:1023–36
74. Nagai T, Sawano A, Park ES, Miyawaki A. 2001. Circularly permuted green fluorescent proteins engineered to sense Ca²⁺. *Proc. Natl. Acad. Sci. USA* 98:3197–202
75. Nakahara S, Hogan V, Inohara H, Raz A. 2006. Importin-mediated nuclear translocation of galectin-3. *J. Biol. Chem.* 281:39649–59
76. Niu TK, Pfeifer AC, Lippincott-Schwartz J, Jackson CL. 2005. Dynamics of GBF1, a brefeldin A-sensitive Arf1 exchange factor at the Golgi. *Mol. Biol. Cell* 16:1213–22
77. Nyfeler B, Michnick SW, Hauri HP. 2005. Capturing protein interactions in the secretory pathway of living cells. *Proc. Natl. Acad. Sci. USA* 102:6350–55
78. Ozalp C, Szczesna-Skorupa E, Kemper B. 2005. Bimolecular fluorescence complementation analysis of cytochrome p450 2c2, 2e1, and NADPH-cytochrome p450 reductase molecular interactions in living cells. *Drug Metab. Dispos.* 33:1382–90
79. Ozawa T, Kaihara A, Sato M, Tachihara K, Umezawa Y. 2001. Split luciferase as an optical probe for detecting protein-protein interactions in mammalian cells based on protein splicing. *Anal. Chem.* 73:2516–21
80. Ozawa T, Natori Y, Sato M, Umezawa Y. 2007. Imaging dynamics of endogenous mitochondrial RNA in single living cells. *Nat. Methods* 4:413–19
81. Park JH, Oufattole M, Rogers JC. 2007. Golgi-mediated vacuolar sorting in plant cells: RMR proteins are sorting receptors for the protein aggregation/membrane internalization pathway. *Plant Sci.* 172:728–45
82. Park K, Yi SY, Lee CS, Kim KE, Pai HS, et al. 2007. A split enhanced green fluorescent protein-based reporter in yeast two-hybrid system. *Protein J.* 26:107–16
83. Park M, Yong YY, Choi SW, Kim JH, Lee JE, Kim DW. 2007. Constitutive RelA activation mediated by Nkx3.2 controls chondrocyte viability. *Nat. Cell Biol.* 9:287–98
84. Paulmurugan R, Gambhir SS. 2003. Monitoring protein-protein interactions using split synthetic *Renilla* luciferase protein-fragment-assisted complementation. *Anal. Chem.* 75:1584–89
85. Paulmurugan R, Umezawa Y, Gambhir SS. 2002. Noninvasive imaging of protein-protein interactions in living subjects by using reporter protein complementation and reconstitution strategies. *Proc. Natl. Acad. Sci. USA* 99:15608–13
86. Pazhouhandeh M, Dieterle M, Marrocco K, Lechner E, Berry B, et al. 2006. F-box-like domain in the poliovirus protein P0 is required for silencing suppressor function. *Proc. Natl. Acad. Sci. USA* 103:1994–99
87. Pelletier JN, Campbell-Valois FX, Michnick SW. 1998. Oligomerization domain-directed reassembly of active dihydrofolate reductase from rationally designed fragments. *Proc. Natl. Acad. Sci. USA* 95:12141–46
88. Peng MS, Hannam C, Gu HL, Bi YM, Rothstein SJ. 2007. A mutation in NLA, which encodes a RING-type ubiquitin ligase, disrupts the adaptability of *Arabidopsis* to nitrogen limitation. *Plant J.* 50:320–37

89. Petry A, Djordjevic T, Weitnauer M, Kietzmann T, Hess J, Gorch A. 2006. NOX2 and NOX4 mediate proliferative response in endothelial cells. *Antioxid. Redox Signal.* 8:1473–84
90. Rackham O, Brown CM. 2004. Visualization of RNA-protein interactions in living cells: FMRP and IMP1 interact on mRNAs. *EMBO J.* 23:3346–55
91. Rajaram N, Kerppola TK. 2004. Synergistic transcription activation by Maf and Sox and their subnuclear localization are disrupted by a mutation in maf that causes cataract. *Mol. Cell. Biol.* 24:5694–709
92. Reidt W, Wurz R, Wanieck K, Chu HH, Puchta H. 2006. A homologue of the breast cancer-associated gene BARD1 is involved in DNA repair in plants. *EMBO J.* 25:4326–37
93. Remy I, Michnick SW. 2004. Regulation of apoptosis by the Ft1 protein, a new modulator of protein kinase B/Akt. *Mol. Cell. Biol.* 24:1493–504
94. Remy I, Michnick SW. 2006. A highly sensitive protein-protein interaction assay based on *Gaussia* luciferase. *Nat. Methods* 3:977–79
95. Remy I, Montmarquette A, Michnick SW. 2004. PKB/Akt modulates TGF-beta signalling through a direct interaction with Smad3. *Nat. Cell Biol.* 6:358–65
96. Richards FM. 1958. On the enzymic activity of subtilisin-modified ribonuclease. *Proc. Natl. Acad. Sci. USA* 44:162–66
97. Rossi F, Charlton CA, Blau HM. 1997. Monitoring protein-protein interactions in intact eukaryotic cells by beta-galactosidase complementation. *Proc. Natl. Acad. Sci. USA* 94:8405–10
98. Schmidt C, Peng BL, Li ZK, Sclabas GM, Fujioka S, et al. 2003. Mechanisms of proinflammatory cytokine-induced biphasic NF-kappa B activation. *Mol. Cell* 12:1287–300
99. Schmidt U, Richter K, Berger AB, Lichter P. 2006. In vivo BiFC analysis of Y14 and NXF1 mRNA export complexes: preferential localization within and around SC35 domains. *J. Cell Biol.* 172:373–81
100. Shimizu H, Sato K, Berberich T, Miyazaki A, Ozaki R, et al. 2005. LIP19, a basic region leucine zipper protein, is a fos-like molecular switch in the cold signaling of rice plants. *Plant Cell Physiol.* 46:1623–34
101. Shyu YJ, Liu H, Deng XH, Hu CD. 2006. Identification of new fluorescent protein fragments for bimolecular fluorescence complementation analysis under physiological conditions. *Biotechniques* 40:61–66
102. Sorkin A, McClure M, Huang F, Carter R. 2000. Interaction of EGF receptor and grb2 in living cells visualized by fluorescence resonance energy transfer (FRET) microscopy. *Curr. Biol.* 10:1395–98
103. Soufo HJD, Graumann PL. 2006. Dynamic localization and interaction with other *Bacillus subtilis* actin-like proteins are important for the function of MreB. *Mol. Microbiol.* 62:1340–56
104. Spotts JM, Dolmetsch RE, Greenberg ME. 2002. Time-lapse imaging of a dynamic phosphorylation-dependent protein-protein interaction in mammalian cells. *Proc. Natl. Acad. Sci. USA* 99:15142–47
105. Stains CI, Porter JR, Ooi AT, Segal DJ, Ghosh I. 2005. DNA sequence-enabled reassembly of the green fluorescent protein. *J. Am. Chem. Soc.* 127:10782–83
106. Stolpe T, Susslin C, Marrocco K, Nick P, Kretsch T, Kircher S. 2005. In planta analysis of protein-protein interactions related to light signaling by bimolecular fluorescence complementation. *Protoplasma* 226:137–46
107. Szczesna-Skorupa E, Kemper B. 2006. BAP31 is involved in the retention of cytochrome P450C2 in the endoplasmic reticulum. *J. Biol. Chem.* 281:4142–48

108. Takahashi Y, Karbowski M, Yamaguchi H, Kazi A, Wu J, et al. 2005. Loss of Bif-1 suppresses Bax/Bak conformational change and mitochondrial apoptosis. *Mol. Cell. Biol.* 25:9369–82
109. Tong EHY, Guo JJ, Huang AL, Liu H, Hu CD, et al. 2006. Regulation of nucleocytoplasmic trafficking of transcription factor OREBP/TonEBP/NFAT5. *J. Biol. Chem.* 281:23870–79
110. Tsien RY. 2003. Imagining imaging's future. *Nat. Rev. Mol. Cell Biol.* Suppl:SS16–21
111. Tsuchisaka A, Theologis A. 2004. Heterodimeric interactions among the 1-amino-cyclopropane-1-carboxylate synthase polypeptides encoded by the *Arabidopsis* gene family. *Proc. Natl. Acad. Sci. USA* 101:2275–80
112. Tzfira T, Vaidya M, Citovsky V. 2004. Involvement of targeted proteolysis in plant genetic transformation by *Agrobacterium*. *Nature* 431:87–92
113. Ullmann A, Jacob F, Monod J. 1967. Characterization by in vitro complementation of a peptide corresponding to an operator-proximal segment of the beta-galactosidase structural gene of *Escherichia coli*. *J. Mol. Biol.* 24:339–43
114. Ullmann A, Jacob F, Monod J. 1968. On the subunit structure of wild-type versus complemented beta-galactosidase of *Escherichia coli*. *J. Mol. Biol.* 32:1–13
115. Ullmann A, Perrin D, Jacob F, Monod J. 1965. Identification par complémentation in vitro et purification d'un segment peptidique de la β -galactosidase d'*Escherichia coli*. *J. Mol. Biol.* 12:918–23
116. Voelker C, Schmidt D, Mueller-Roeber B, Czempinski K. 2006. Members of the *Arabidopsis* AtTPK/KCO family form homomeric vacuolar channels in planta. *Plant J.* 48:296–306
117. Walter M, Chaban C, Schutze K, Batistic O, Weckermann K, et al. 2004. Visualization of protein interactions in living plant cells using bimolecular fluorescence complementation. *Plant J.* 40:428–38
118. Wang KZQ, Wara-Aswapati N, Boch JA, Yoshida Y, Hu CD, et al. 2006. TRAF6 activation of PI 3-kinase-dependent cytoskeletal changes is cooperative with Ras and is mediated by an interaction with cytoplasmic Src. *J. Cell Sci.* 119:1579–91
119. Wang T, Hu YC, Dong SZ, Fan M, Tamae D, et al. 2005. Co-activation of ERK, NF-kappa B, and GADD45 beta in response to ionizing radiation. *J. Biol. Chem.* 280:12593–601
120. Wehr MC, Laage R, Bolz U, Fischer TM, Grünewald S, et al. 2006. Monitoring regulated protein-protein interactions using split TEV. *Nat. Methods* 3:985–93
121. Wehrman T, Kleaveland B, Her JH, Balint RF, Blau HM. 2002. Protein-protein interactions monitored in mammalian cells via complementation of beta-lactamase enzyme fragments. *Proc. Natl. Acad. Sci. USA* 99:3469–74
122. Xu XM, Moller SG. 2006. AtSuffE is an essential activator of plastidic and mitochondrial desulfurases in *Arabidopsis*. *EMBO J.* 25:900–9
123. Yano A, Kodama Y, Koike A, Shinya T, Kim HJ, et al. 2006. Interaction between methyl CpG-binding protein and Ran GTPase during cell division in tobacco cultured cells. *Ann. Bot.* 98:1179–87
124. Ye HH, Choi HJ, Poe J, Smithgall TE. 2004. Oligomerization is required for HIV-1 nef-induced activation of the Src family protein-tyrosine kinase, Hck. *Biochemistry* 43:15775–84
125. Zhao XH, Xu JR. 2007. A highly conserved MAPK-docking site in Mst7 is essential for Pmk1 activation in *Magnaporthe grisea*. *Mol. Microbiol.* 63:881–94
126. Zhu LQ, Tran T, Rukstalis JM, Sun PC, Damsz B, Konieczny SF. 2004. Inhibition of Mist1 homodimer formation induces pancreatic acinar-to-ductal metaplasia. *Mol. Cell. Biol.* 24:2673–81

Contents



Annual Review of
Biophysics

Volume 37, 2008

Frontispiece	
<i>Robert L. Baldwin</i>	xiv
The Search for Folding Intermediates and the Mechanism of Protein Folding	
<i>Robert L. Baldwin</i>	1
How Translocons Select Transmembrane Helices	
<i>Stephen H. White and Gunnar von Heijne</i>	23
Unique Rotary ATP Synthase and Its Biological Diversity	
<i>Christoph von Ballmoos, Gregory M. Cook, and Peter Dimroth</i>	43
Mediation, Modulation, and Consequences of Membrane-Cytoskeleton Interactions	
<i>Gary J. Doberty and Harvey T. McMahon</i>	65
Metal Binding Affinity and Selectivity in Metalloproteins: Insights from Computational Studies	
<i>Todor Dudev and Carmay Lim</i>	97
Riboswitches: Emerging Themes in RNA Structure and Function	
<i>Rebecca K. Montange and Robert T. Batey</i>	117
Calorimetry and Thermodynamics in Drug Design	
<i>Jonathan B. Chaires</i>	135
Protein Design by Directed Evolution	
<i>Christian Jücker, Peter Kast, and Donald Hilvert</i>	153
PIP ₂ Is A Necessary Cofactor for Ion Channel Function: How and Why?	
<i>Byung-Chang Sub and Bertil Hille</i>	175
RNA Folding: Conformational Statistics, Folding Kinetics, and Ion Electrostatics	
<i>Shi-Jie Chen</i>	197
Intrinsically Disordered Proteins in Human Diseases: Introducing the D ² Concept	
<i>Vladimir N. Uversky, Christopher J. Oldfield, and A. Keith Dunker</i>	215
Crowding Effects on Diffusion in Solutions and Cells	
<i>James A. Dix and A.S. Verkman</i>	247

Nanobiotechnology and Cell Biology: Micro- and Nanofabricated Surfaces to Investigate Receptor-Mediated Signaling <i>Alexis J. Torres, Min Wu, David Holowka, and Barbara Baird</i>	265
The Protein Folding Problem <i>Ken A. Dill, S. Banu Ozkan, M. Scott Shell, and Thomas R. Weikl</i>	289
Translocation and Unwinding Mechanisms of RNA and DNA Helicases <i>Anna Marie Pyle</i>	317
Structure of Eukaryotic RNA Polymerases <i>P. Cramer, K.-J. Armache, S. Baumli, S. Benkert, F. Brueckner, C. Buchen, G.E. Damsma, S. Dengl, S.R. Geiger, A.J. Jasiak, A. Jawhari, S. Jennebach, T. Kamenski, H. Kettenberger, C.-D. Kubn, E. Lehmann, K. Leike, J.F. Sydow, and A. Vannini</i>	337
Structure-Based View of Epidermal Growth Factor Receptor Regulation <i>Kathryn M. Ferguson</i>	353
Macromolecular Crowding and Confinement: Biochemical, Biophysical, and Potential Physiological Consequences <i>Huan-Xiang Zhou, Germán Rivas, and Allen P. Minton</i>	375
Biophysics of Catch Bonds <i>Wendy E. Thomas, Viola Vogel, and Evgeni Sokurenko</i>	399
Single-Molecule Approach to Molecular Biology in Living Bacterial Cells <i>X. Sunney Xie, Paul J. Choi, Gene-Wei Li, Nam Ki Lee, and Giuseppe Lia</i>	417
Structural Principles from Large RNAs <i>Stephen R. Holbrook</i>	445
Bimolecular Fluorescence Complementation (BiFC) Analysis as a Probe of Protein Interactions in Living Cells <i>Tom K. Kerppola</i>	465
Multiple Routes and Structural Heterogeneity in Protein Folding <i>Jayant B. Udgaonkar</i>	489

Index

Cumulative Index of Contributing Authors, Volumes 33–37	511
---	-----

Errata

An online log of corrections to *Annual Review of Biophysics* articles may be found at <http://biophys.annualreviews.org/errata.shtml>