

Biointegrated and Wirelessly Powered Implantable Brain Devices: A Review

Rupam Das , *Member, IEEE*, Farshad Moradi , *Senior Member, IEEE*, and Hadi Heidari , *Senior Member, IEEE*

Abstract—Implantable neural interfacing devices have added significantly to neural engineering by introducing the low-frequency oscillations of small populations of neurons known as local field potential as well as high-frequency action potentials of individual neurons. Regardless of the astounding progression as of late, conventional neural modulating system is still incapable to achieve the desired chronic *in vivo* implantation. The real constraint emerges from mechanical and physical differences between implants and brain tissue that initiates an inflammatory reaction and glial scar formation that reduces the recording and stimulation quality. Furthermore, traditional strategies consisting of rigid and tethered neural devices cause substantial tissue damage and impede the natural behavior of an animal, thus hindering chronic *in vivo* measurements. Therefore, enabling fully implantable neural devices requires biocompatibility, wireless power/data capability, biointegration using thin and flexible electronics, and chronic recording properties. This article reviews biocompatibility and design approaches for developing biointegrated and wirelessly powered implantable neural devices in animals aimed at long-term neural interfacing and outlines current challenges toward developing the next generation of implantable neural devices.

Index Terms—Biocompatibility, biointegration, implantable neural device, mechanical flexibility, wireless power transfer.

I. INTRODUCTION

ADVANCES in neural engineering and related experimental methods improved our understanding of the brain. As for an example, progress in fMRI (functional magnetic resonance imaging) technologies expanded our insight of neuronal circuits and help us to understand how specific brain activity linked to different neural circuits [1]. However, size and portability limit the use of such neuroimaging tools to explore brain activity during daily living [2]. Furthermore, another crucial constraint of fMRI in brain research is the low spatiotemporal resolution.

Manuscript received July 28, 2019; revised September 27, 2019 and December 14, 2019; accepted January 11, 2020. Date of publication January 15, 2020; date of current version March 27, 2020. This work was supported in part by the European Union's Horizon 2020 Hybrid Enhanced Regenerative Medicine Systems (HERMES) Project under Grant Agreement no. 824164, in part by EPSRC, U.K., Reference no. EP/R511705/1, in part by the Scottish Research Partnership in Engineering (SRPe) Funder Reference no. PEER1718/03, and in part by FM supported by STARDUST Project under Grant Agreement no. 767092. (Corresponding author: Hadi Heidari.)

R. Das and H. Heidari are with Microelectronics Lab (meLAB), School of Engineering, The University of Glasgow, G12 8QQ Glasgow, U.K. (e-mail: rupam.das@glasgow.ac.uk; hadi.heidari@glasgow.ac.uk).

F. Moradi is with the Integrated Circuits and Electronics Lab (ICELab), Electrical Engineering Department, Aarhus University, Aarhus 8200, Denmark (e-mail: moradi@eng.au.dk).

Color versions of one or more of the figures in this article are available online at <https://ieeexplore.ieee.org>.

Digital Object Identifier 10.1109/TBCAS.2020.2966920

In contrary, portable surface electroencephalography (EEG) permits the uninterrupted monitoring and evaluation of brain activity macroscopically for a long period of time [3], [4]. However, same as with fMRI, the low spatiotemporal resolution of EEG sabotages the accuracy of measurement and is incompatible with neuroscience studies on scenarios such as single-neuron resolution. Individual neurons constitute the morphological as well as operational units of the brain and their spatiotemporal recordings are key to properly understand the brain function. Nowadays, to record extracellular activities, including action potentials and local field potentials (LFPs), implantable neural devices are most commonly used [5], [6].

These invasive and implantable neural interfacing devices are widely applied in different clinical scenarios for example, peripheral, and spinal nerve interfaces for monitoring epilepsy, cochlear and retinal implants, and as deep brain stimulators [7]–[11]. Like most of the implantable devices, the exceedingly dynamic and corrosive condition of the biological tissue is antagonistic to implants. The vulnerability originates due to mechanical and physical mismatch linking the implants and brain tissues which causes scar formation and introduces neuroinflammatory response, thus, gradually degrades the recorded neural signal [12]–[14]. As a result, implantable neural devices are required to be bioinert, physically soft and small enough to complement those of brain tissues. The goal is then developing neuron-like, multifunctional neural engineering platforms or neuroprostheses interfaces that enforce significantly low constraints on the normal environments of the brain and incites negligible inflammatory responses.

Implantable neural devices based on tethered and rigid devices initiate considerable tissue damage and disturbance with the normal behaviour of animals, thereby hampering chronic *in vivo* operations [15]–[18]. The mechanical mismatch and micro-motion introduced by the interconnection that links the neural implant placed near the brain and skull-mounted connector (i.e., tether), can be minimized by using a wireless power system. The most commonly used wireless power technologies used are electromagnetic, photovoltaic, and ultrasound [15], [18]. The ultrasound-based power transfer method uses ultrasound to vibrate an energy harvester based on implantable piezoelectric. On the other hand, photovoltaic wireless power harvesting is based on the conversion of light into electricity by using photovoltaic cells. Although innovative, these wireless solutions are limited due to the complex circuitry and low power transfer distance. As a result, the electromagnetic based wireless power transfer, which working principle is the electromagnetic induction,

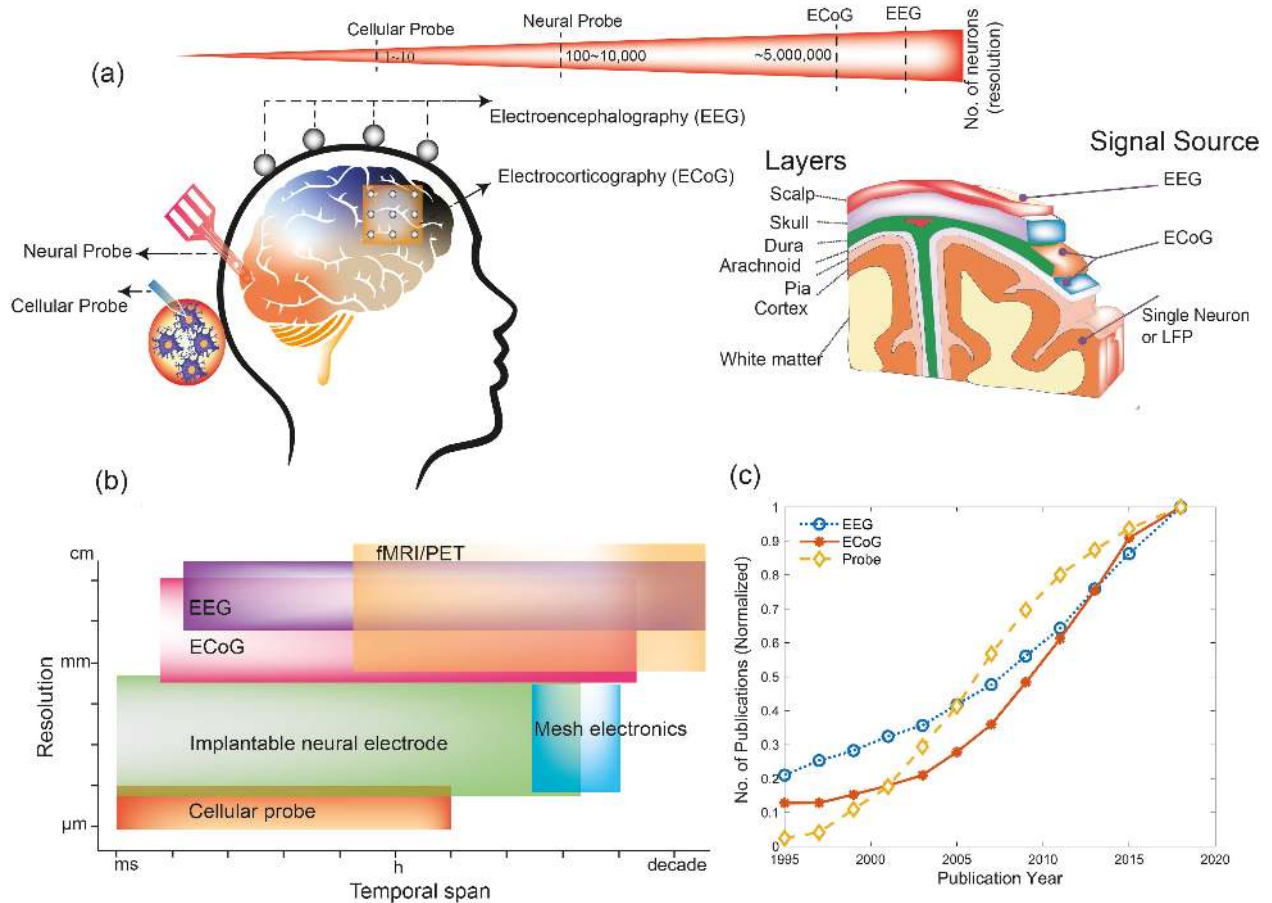

Fig. 1. Examples of neural recording systems. (a) EEG probes are placed non-invasively on the brain scalp to record the neuronal activity. ECoG electrodes enable recording of neural activity on the cortical surface and implanted either inside (subdural) or outside (epidural) the dura mater. Implantable neural or cellular electrodes facilitates recording/stimulation from small numbers of neurons or individual neurons by penetrating the cortex and. (b) Fundamental principles and anatomical limitations of neural recording methods. Illustrate the trade-off and indicates an interrelation between the amount of temporal dynamics of neural technology and the spatiotemporal resolution that can be attained. (c) Demonstrate the current research trend on neural interfaces. The data were collected from the Web of Science by searching keywords such as EEG, ECoG, and implantable neural probe. To show the relative comparison of the research rate from 1995 to 2018 among these technologies, the number of publications is normalized for each case.

still the most popular choice to realize the fully implantable, wirelessly powered, and miniaturized neural devices for chronic implantation [15], [16], [18].

This paper studies novel design approaches for developing soft, flexible and wireless interfaces of implantable neural devices by manifesting physical and mechanical consistency with brain tissues. The review starts by considering different neural interfaces, incorporating key parameters to consider for implantable neural probes. Following sections highlights the challenges and progress in implantable probe biointegration using circuit analysis of the probe/tissue interface. In Section III, most of the common wireless power modalities for implantable neural interface have been addressed including electromagnetic, ultrasound, and solar. Finally, there is a conclusion section, followed by the discussion on the state of the implantable neural interface suggesting scopes for future studies.

II. NEURAL DEVICE INTERFACES

Implantable neural probe (or electrode/device) defines as the interface between brain-machine interface (BMI) system

and neurons—the electroactive cells of the nervous system. Basically, implantable neural devices were evolved as a fundamental neuroscience tool to enhance the understanding of physiological processes [19]–[22], and in BMI neural interfaces occupy exceptional ability to substitute for function of the various neurological disorders such as paralysis, epilepsy, other forms of motor dysfunction, or limb loss. The motivation behind developing neural devices is to provide adequate neural stimulation and/or to record the high quality neural signal from a few individual neurons, named action potentials [14].

Brain signals may be categorized into EEG [23], electrocorticogram (ECoG) [24], [25], LFPs [26], and action potential [27], based on the location of the recorded signal. A correlation between the position and quality of the acquired signal among different neural technologies is displayed in Fig. 1(a). EEG (scalp recordings) is the most basic, non-invasive technique to record brain activity, which has found application in the treatment of seizure or epilepsy. EEG also helps to monitor sleep, enables a better understanding of language perception and psychological function of the brain [28]–[31]. However, due to several interfering LFPs, EEG is unable to offer nearby

data concerning a specific brain region, and suffers from low transfer rates e.g., 5–25 bit/s [32], [33]. Furthermore, brain tissues are lossy and packed densely, and other brain layers such as skin and cranium function as obstacles that attenuate recorded EEG signal to the surface electrode, thereby limiting the spatiotemporal resolution [34]. In contrast, current researches have evaluated the application of invasive BMI such as ECoG (epidural/subdural recordings). As compared to the EEG, ECoG reduces the noise interference and allows to record higher frequency neural signal with higher accuracy. This is due to the fact that the ECoG electrodes are implanted within the cortex, thus accommodating lower tissue interference between the neurons and the electrodes [35]. Still, however, ECoG just records neural signals from superficial locales of the brain and unable to collect activity from individual neurons. Gathering signals from individual neurons and accuracy in spatiotemporal resolution over a particular neuron population is fundamental to facilitate a more profound understanding of the human sensory and cognitive system. Consequently, a more invasive method using implantable neural probes collect the LFPs signal from the deep brain region. The recording of LFPs signifies local neural activities which are obtained from specific neuronal densities and comprises action potentials as well as additional membrane potential fluctuations, and provides noteworthy details about the measured brain area [36].

Fundamentally, the idea of neural recording relies upon the application that we are focusing on. For an identical activity of the brain, the recorded signal is varied depending on the interfacing technique and recorded signal location. According to Fig. 1(b), EEG or fMRI help us to examine neural activity from the identical subject for a longer period with a low resolution, whereas an implantable neural probe can achieve neuronal scale resolutions with a short temporal span. From the historical perspective, the field of neural interfaces has shown an upward trend as evidenced in Fig. 1(c). This study is based on the number of publications (normalized) in the field of neural interfaces since the early 1990s. Among these, the current research trend indicates a significant development towards the implantable neural probe compared to the EEG and ECoG. Ongoing investigations proposed single-neuron activity enables us to guide and better comprehend the wiring of the cerebrum and its connection to discernment, movement, and memory. Nowadays, implantable neural device utilized for confining epileptogenic regions and treating Parkinson's disease. As compared to EEG and ECoG, the implantable neural device is considered to generate the most valuable control signals for neural interfacing [35], [36]. These findings crave more breakthroughs in implantable device technologies to have more higher resolution, spatiotemporal span, and multiplexed functionality for neural recordings and stimulations.

Recent progress in the field of materials science, stimulation types, system engineering, and mechanical design can facilitate long term in vivo recordings in freely moving animals by using implantable neural probes [5], [16]. Some key system parameters for designing implantable neural probes appear in Fig. 2. In all scenarios, a critical objective is to design a fully implantable, miniaturize, flexible, biointegrated, and wireless platforms [15],

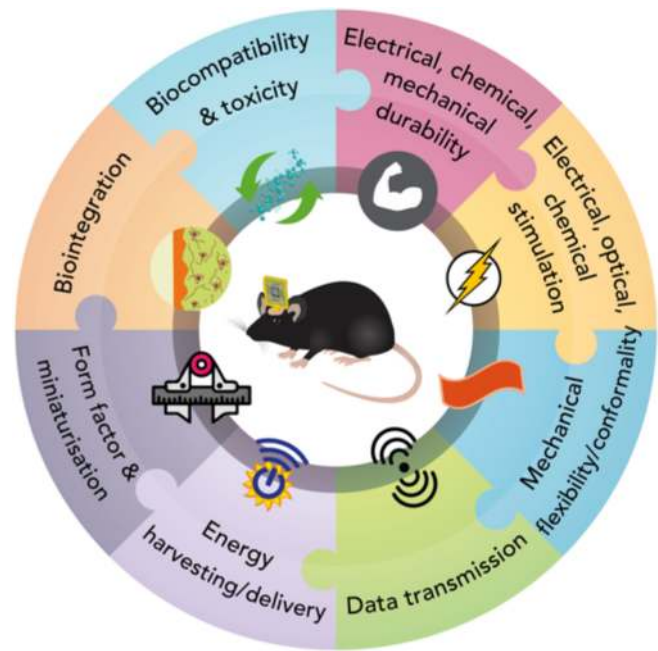

Fig. 2. Schematic illustration of the key parameters in neuroscience research for implantable device. Examples of emerging tools include biointegration, biocompatibility, device miniaturization, wireless power and data transmission, stimulation types, mechanical flexibility, and electro-chemical durability.

[17], [18], [37]–[40]. Use of biocompatible material plays an important role both chemically and mechanically, and prerequisite to permit a durable, least invasive operation of the brain [41]. Along with the critical importance of the biocompatibility, mechanical flexibility as well as conformality to the desired tissues forms the foundation of a long-term biointegration [42]. Furthermore, wireless power transfer (WPT) to the neural implant ensures tether-free, highly mobile social connections or recordings in naturalistic situations for the tested animals [15], [17], [18]. In summary, reducing the size and weight is an inevitable engineering prospect [5].

III. RECENT TREND IN PROBE/TISSUE BIOINTEGRATION

A. Equivalent Circuit Analysis of the Probe/Tissue Interface

Neural recordings using implanted devices can detect a change in the extracellular field because of ion fluxes in the nearby condition, which permits recording of the small population activity as LFPs ($< \sim 350$ Hz), and, in certain situations, the spiking action or action potentials of single-neuron (\sim kHz). The impedance is defined as the resistance to the current that flows between the implanted probe and interface of the tissue. The impedance estimates the capacity to record the pathological and physiological neural sign or for neural stimulation. By making use of the equivalent circuit model illustrated in Fig. 3(a), the probe/tissue effective impedance can often be modelled, understood, and optimized. Here, V_e is the signalling in the neuron and accepted as a low-impedance voltage source. R_{spread} (or, R_{media}) indicates the impedance of the extracellular space and is dictated by the implanted device geometry. Besides, R_e is the

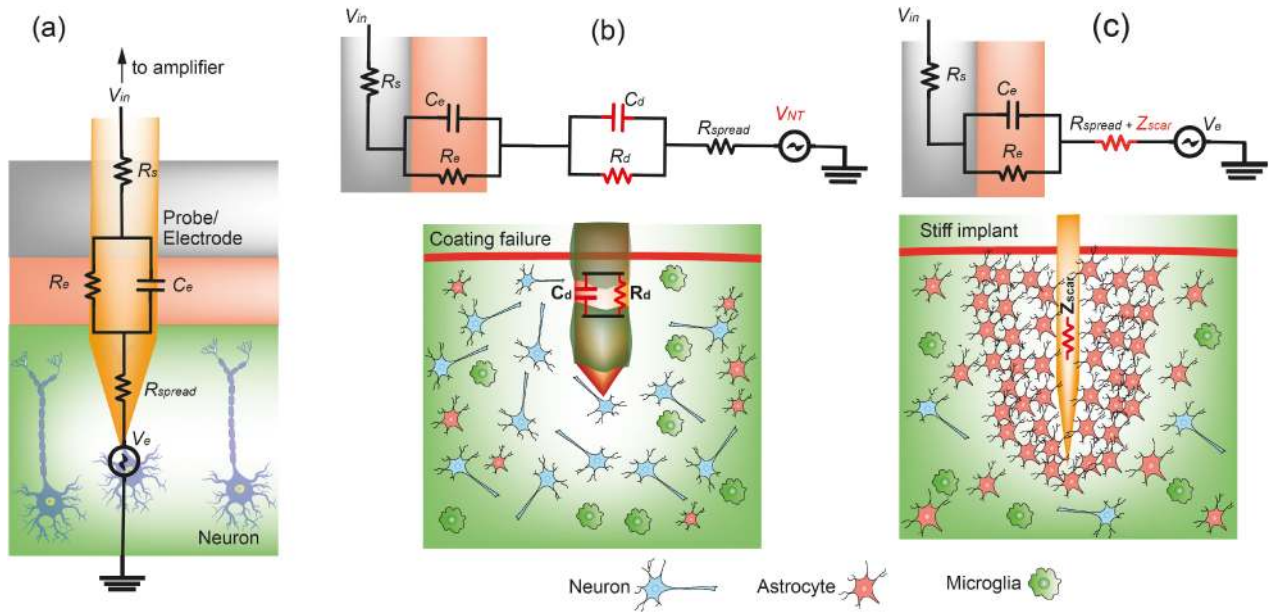

Fig. 3. (a) Probe/tissue interface equivalent circuit. For simplicity, recording is assumed where, neurons operate like a voltage source (V_e). Nonetheless, stimulation circuit can also be represented similarly. (b) Schematic of the encapsulation failure of the implantable neural device and corresponding equivalent circuit. (c) Graphical illustration of the foreign-body response to a stiff implant in the brain and associated equivalent circuit.

leakage resistance of the electrode and C_e characterizes the capacitance of the probe/tissue interface. Finally, R_s defines the resistance that exists in case of higher-level hardware, for example amplifiers. The magnitude of R_s can be negligible or significant depending on the interconnection used to record/transmit signals [43], [44]. In general, a lower impedance probe/tissue interface is desired and permits us to “see” the neural signal (V_e) more promptly. Like recording, implantable neural device stimulation is strengthened with a low probe/tissue interface resistance as well and results in a significant charge injection. Hence, having a low impedance interface is crucial in μm -scale electrodes for neural recording/stimulation. As both recording and stimulation circuits are identical to Fig. 3(a), a ms -scale biphasic current stimulation introduces a momentary voltage incorporating rapid step, because of R_{spread} , and initiates a capacitive charging due to C_e [45]. Consequently, a small value of C_e facilitates the significant potential drops at the neural interface. This may introduce electrolysis of water, degradation of electrode, as well as tissue damage.

Recent advancement in the microelectronics manufacturing promoted the development of patterned, micromachined, and rigid probes [46]. Nowadays, the state-of-the-art devices like Michigan-style probes [47] and Utah arrays [48] are commercially available and has been utilized in neuroscience research. Furthermore, emerging Silicon-based implantable probe technologies such as Neuropixels for high-density neural recordings [49], multifunctional probe [50], as well as 3D probe for recording of coordinated brain activity from large population of neurons [51] have enriched us with new insights to study the brain. Regardless of numerous triumphs and creative revelations in neuroscience (from the disclosure of spot and framework cells to mapping and motor cortex stimulation), still implantable neural devices face numerous limitations that circumscribe their

chronic implementation. Owing to the rigid nature of the implanted devices, it frequently prompts insulation failure and limits the recording/stimulating ability [52]. Accordingly, recording quality, stimulation limit, and life expectancy of an implantable neural device can be condensed down to its capacity to oppose or defeat increments in electrical impedance. Due to the surgical procedure of the implantable neural device, it presents both intense (acute) and constant (chronic) tissue damage, notwithstanding, there are more spotlights on the probe/tissue biointegration and lifetime instead of the impact on neurological function [35]. In the following subsections some of the critical aspects of the implant/tissue biointegration will be addressed in terms of electrical viewpoint along with the approaches to alleviate these issues.

B. Interruption in Probe/Tissue Circuit Due to Implantation Failures

Poor encapsulation, material defects, and/or potentially unintended mechanical stresses causes cracking and delamination of the device [53]. Encapsulation failure, which occurs in between a week or a month after implantation, may expose the metallic interconnects. Insulation damage introduces additional resistive and capacitive pathways for current to flow (R_d and C_d in Fig. 3(b)). This results in a false neural signal (or, noise) V_{NT} from undesired cells [54], [55]. In addition, the amplitude of the neural recording is diminished due to the low impedance shunting pathways of the neighbourhood condition. Likewise, these equivalent shunt pathways may divert current and stimulate non-target cells, decreasing stimulation ability.

Corrosion due to chemical deterioration of the material used in the electrode presents a twofold negative impact. First, it destroys the conductive properties of the metallic interconnects

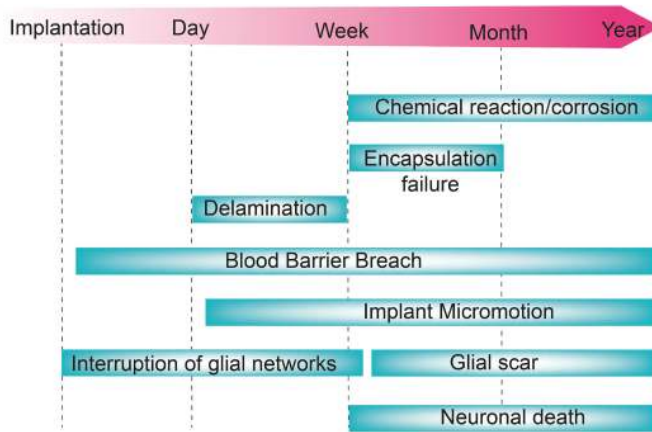

Fig. 4. Failure modes of neural device include chemical reaction or corrosion, encapsulation failure, delamination or cracking of insulation. Failures related to biology include blood barrier breach, implant micromotion, interruption of glial networks, formation of glial cells and neuronal death, recreated from [55].

(thus, expanding R_s as well as diminishing C_e) and secondly, accommodating brain with harmful toxic ingredients, subsequently, expanding the immune response or causes cell death [35]. Careful materials choice and/or synthesis are vital in realizing a chemically stable and properly insulated implantable neural electrode.

Though acute tissue damage because of the implanted neural probe in the brain could expeditiously recuperate, it is the long haul tissue response, and consequent inflammation at the implant site, that effectively adds to debasing the probe/tissue biointegration [56], [57]. The neuroinflammatory reaction within the central nervous system of the brain is defined as the reaction of the immune system and is made from a blend of cellular and biochemical reactions, which detaches foreign components (for example, an implanted probe) from the tissue. During the acute stage, the surface of the implanted device attracts and activates microglia (central nervous system immune cell), which releases pro-inflammatory factors. Shortly thereafter, a thick astrocyte wraps the implanted neural device and the response advances to a chronic stage, where a scar (astrogliosis) is formed, as visualized in Fig. 3(c). This chronic reaction, which is responsible for distancing the neuron from the implantation site can be caused by several factors [58]. In accordance with electrical interfacing, astrogliosis and the distancing of neurons near the implanted sites are in charge of (i) the introduction of additional impedance (Z_{scar}) and (ii) diminishing the amplitude of the neural recordings since living neurons are less and remotely away from the implant site (Fig. 3(c)). According to the both theory and experiments, the most extreme permissible separation between the probe and the cell membrane for a steady recording extends somewhere in the range of 50 and 100 μm [58]. An overview of the different failures upon the implantation of a probe into the intracortical tissue is illustrated in Fig. 4.

C. Recent Advancement in Probe/Tissue Biointegration

Biocompatibility of the neural interface can be evaluated quantitatively based on the estimation of the neuron population

as a function of the distance from the implant. Furthermore, the spread of the neuroinflammation [59] and causes of neural interfacing failure can be examined by either electrochemical impedance spectroscopy [60] or optical analysis [61]. To enhance the biointegration of the implantable neural probe, biocompatibility holds the key.

Biological compatibility or biocompatibility depends on the material properties (*e.g.*, chemical, mechanical and physical) of the implant. In general, biocompatibility is characterized as the capacity of a biomaterial to fulfil its ideal operation regarding a medicinal treatment, without inspiring any bothersome local or systematic effects in the recipient, yet producing the most proper cell or tissue reaction in that specific circumstance, and enhancing the clinically applicable presentation of that treatment [62]. Thus, a few methodologies have been proposed to improve the biocompatibility, for instance, enhanced device encapsulations can beat the electrical impacts from scar formations, and a decrease in device corrosion can limit the initiated neuroinflammatory responses. However, mechanical discrepancy between probe/tissue interface affects the long-term biocompatibility of the implanted neural device.

Lack of mechanical uniformity between the brain and implanted device and micromotions are both associated with scar formation. A mechanically compliant device to the neural tissue is expected to enable the implanted device to pursue the movements of the brain. Bending stiffness and Young's modulus are the two physical quantities that are normally used to depict inflexibility or the protection from a twist or deformation. In identifying the amount of mechanical incompatibility, the bending stiffness of a specific implantable neural device is more critical than Young's modulus [55], [63]. Fig. 5(a) represents the scope of Young's moduli of different neural devices and neural tissue. To add more, the compelling bending stiffness estimations of traditional and emergent neural devices [64]–[69] alongside that of a 20–100 μm thick slice of brain tissue [70], are plotted in Fig. 5(b). Consequently, the mitigation of mechanical mismatch can be approached from two directions. Firstly, making polymer based flexible neural device as polymers such as Parylene C, polyimide, or SU-8 are softer than bulk Si and metals. Recently, S. Guan *et al.* introduced the Neurotassel probe based on polyimide comprising of numbers of flexible and high-aspect ratio microelectrode filaments, which can provide chronic recordings 3–6 weeks after implantation [71]. However, polymer based neural devices are still significantly stiffer than tissue. Shifting to increasingly agreeable materials, for example, Polydimethylsiloxane (PDMS) or hydrogel coatings shuts this gap [35], [42], as in Fig. 5(a). Implantable neural probes based on the elastomeric substrate (*e.g.*, PDMS) can be stretchable and enable chronic multimodal neuromodulation applications [72]. The second method recommends stiff materials such as polymers, metals, and semiconductor can be utilized if the characteristics dimensions of the implanted probes are in subcellular scale (1 to 10 μm) to take into account mechanical consistency [35].

Fig. 5(c) shows the some of the current research trends in designing the biointegrated implantable neural probe. Most of the recent neural devices based on ultra-small carbon [68], [73], polyimide [65] and elastomer-based 'e-dura' probes [72], as

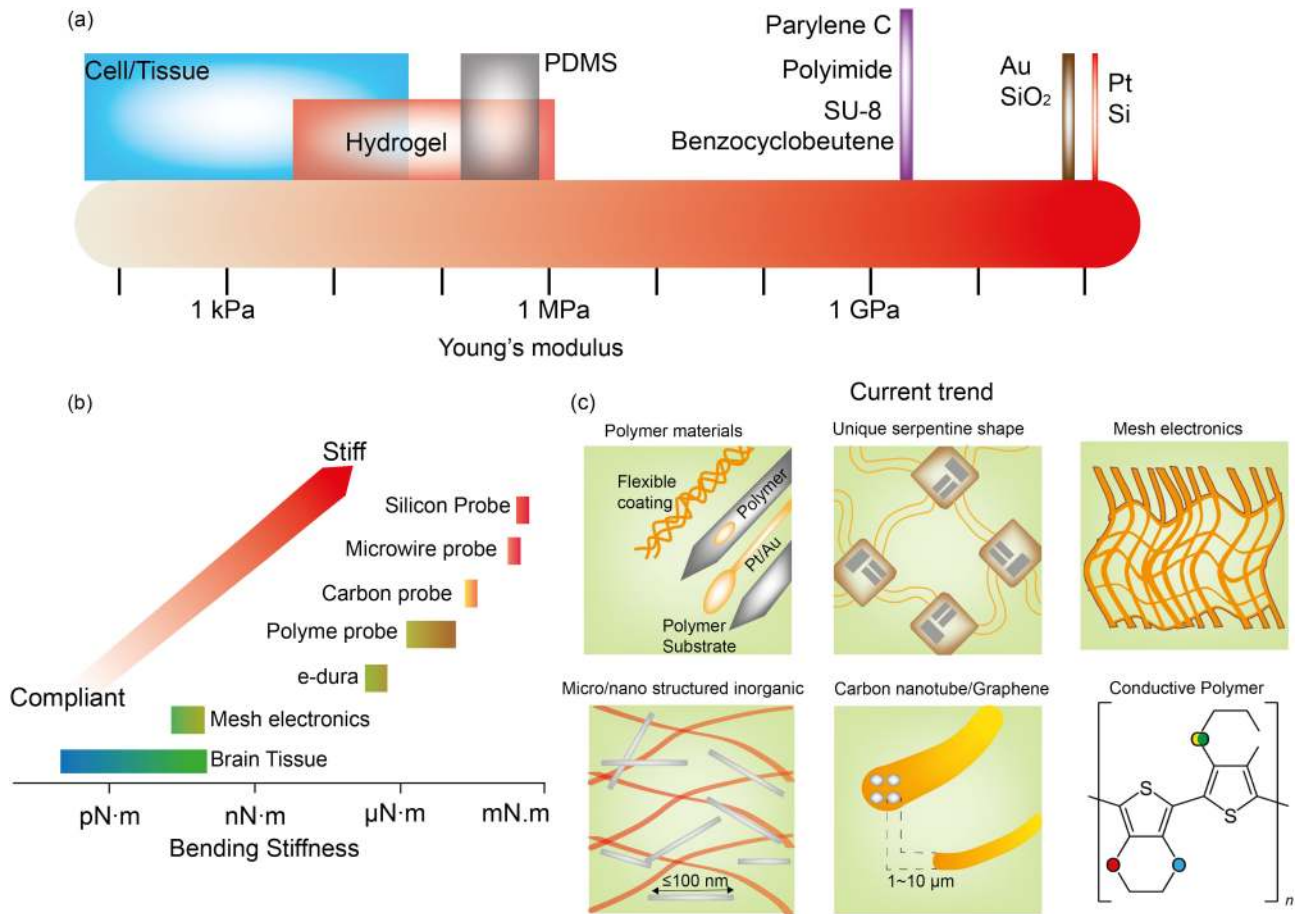

Fig. 5. (a) Schematic illustration of Young's modulus of common materials and tissue demonstrate the mechanical compatibility between the rigid materials (metals, Si, oxides; left), against the elastomers like PDMS (middle) (b) Comparison of bending stiffness among traditional and recent implantable neural devices. (c) Current trend in implantable neural device designing includes use of biocompatible polymers, unique serpentine structure, mesh electronics, conductive polymer, and nanostructures.

well as traditional microwire and Michigan-type silicon devices are still considerably stiffer than the brain tissue. Moreover, probe/tissue biointegration often requires stretch ability (a low-modulus, elastic reaction to huge strain distortions) and this can be accomplished with characteristically resilient materials or through introducing deterministic, composite shapes utilizing serpentine structures, and wavy structures. To promote the neuronal attachment, extracellular matrix, which is a passive covalent attachment can also be used. As for an example, fixed astrocyte extracellular matrix offers more reduction in microglial activation as compared to the individual extracellular matrix components such as laminin or fibronectin [74]–[76]. By exploiting the reliance of bending stiffness on implanted device size, only the mesh electronics associated with compelling mechanical properties practically identical to that of neural tissue (Fig. 5(b)).

The chronic performance of the neural devices mostly depends on their dimensions, stability of their material and functionalities, proper encapsulations, and mechanical properties to reduce the foreign body response. Glial scar formation and displacement of tissue can be diminished by miniaturizing the size of the device, which can be achieved by reducing the

cross-sectional area to decrease the stiffness of the device. As a result, reduction of implant dimensions to below several microns increase the bendability of neural devices, which results in less displacement and glial scar [77]–[79]. The application of emerging materials such as carbon fibre (7 μm in diameter) for long-term recording of neural activities has induced minor gliosis and neuron loss [80]. However, developing carbon fibre arrays is a difficult task and one electrode site per fibre limits the carbon fibre array configuration. On the other hand, recently a mesh electronics array configuration called neuron-like electronics (NeuE) has been proposed with features sizes analogous to the neuron axon and attunes extremely low bending forces, which results in minimum inflammation and foster implant-neuron interaction [81]. Consequently, such mesh electronics are chronically stable for recording up to 3 ~ 8 months [5], [35], [81]. However, the trade-off remains as a syringe is required to inject the mesh electronics without having the precise control over the implantation [66]. Furthermore, neuron-scale devices are yet to showcase their length of service to confirm the applicability in larger animals.

To reduce mechanical discrepancy between the brain tissue and the implantable device, a hot topic of research is the

use of a soft and flexible [82]–[84] or stretchable [85]–[88] system for implantable neural device. Although flexible and stretchable/elastic implants have achieved minimum foreign body response when implanted chronically, thorough and outright correlation in performance for chronic recording between flexible and conventional silicon/metal devices is required to be investigated. On the other hand, such flexible and soft devices also introduce complexities in implanting the device inside the brain. To this end, these problems are managed by using encapsulation approaches such as silk [89], carboxymethyl cellulose [90], syringe injection shuttles [66], [91], or magnetic insertion [92]. As current trends are progressing towards making these devices smaller and more flexible, more advanced and durable biocompatible materials are desirable. Then again, ultra-small and flexible devices are susceptible to material and physical failure due to their geometry. Thin encapsulation is another essential criterion for these devices. Most commonly used flexible polymers (e.g., Polyimide and Parylene C) for ultrathin ($<1 \mu\text{m}$) encapsulations have difficulties in chronic stability and reliability [93], expressing the need of further improvement on insulation materials/methods. Upon stretching/flexing, materials require to exhibit both conductivity as well as flexibility. A promising advancement in elastic conductors has been revealed through nanoconfinement effect [94]. The application of such materials for implantable neural implants is yet to be explored.

The impedance of the electrode increases, if its size is minimized to record or stimulate single or small numbers of neurons. There is a well-known trade-off between the electrode area and impedance. While averaging over a big population of neurons, in general, bigger regions decrease R_{spread} and add to the capacitance, C_e . In any case, the need to quantify action potentials of individual neurons with a high-resolution proportion has prompted a staggering spotlight on augmenting C_e while minimizing the implantable device size. Surface alteration of the electrode by strategies, for example, nanostructured coatings and including composite films made of carbon nanomaterials have been broadly explored [95]. Nanostructured coatings permit a critical increment in the surface area of the probe/tissue interface and are regularly utilized for multielectrode arrays. An indistinguishable methodology has been taken with carbon nanostructures (carbon nanotubes and graphene) [96], [97] as well as their composites, and results in an identical results [98]. Carbon nanotubes (CNT) based Magnetic Resonance Imaging (MRI) compatible neural probes have also been developed to combine functional MRI (fMRI) studies across entire brain regions without any electrode interferences [99]. Likewise, conductive polymers present another unique option to improve the performance of the electrode. Conductive polymers such as poly(3,4-ethylenedioxythiophene) (PEDOT) and Polypyrrole can give a mix of ionic infiltration and adequate pathways for electronic conduct, which yield remarkable increment in capacitance per unit geometric surface area than normal metallic electrodes and, therefore, improve both recorded signal strength and stimulation capacity [45]. Conductive polymers can be promptly functionalized through physical ensnarement and covalent cross-connecting with biomolecules and cells, which can viably dim the biotic/abiotic interface and improve biointegration [44], [95], [100], [101]. Additionally,

to ease the functionality and improve the stability, advanced conductive polymers have been investigated in dopants for neural recording [78], [102] and drug delivery [103]. These novel polymer coatings enable more reduction in dimension for implantable neural devices.

The aforementioned strategies improve the mechanical and physical properties of the implanted neural devices to promote biocompatibility for probe/tissue biointegration. However, the recorded signal quality is affected due to miniaturized device size, number of channels, high signal-to-noise ratio, or less invasive approaches [104]. As a result, in addition to softness and biocompatibility of the device, further design methods and traits are also necessary. However, a detailed discussion on these topics is beyond the scope of this review. Table I summarizes and compares different properties of emerging electrode technologies.

D. Stimulation and Closed-Loop Implantable Neural Devices

For stimulation, electrical or focal brain stimulation is the conventional technique used in BMI. For instance, epilepsy is now treated by electrical stimulation of vagus nerve. However, electrical stimulation of undesired neurons introduces shortness of breath, cough, throat pain, thereby restricting the extent of this approach [105]. This method has also been applied for motor control in patients having stroke and spinal cord injury to excite the paralyzed muscles [106]. Such stimulation of the paralyzed muscles, nevertheless, wear out the muscle strength due to the disorganized enlisting of unwanted motor elements [107], and unable to confine muscle contractions in spasticity.

Recently, optogenetics [108], [109], where light is used to stimulate the genetically modified neurons, has enlighten with another unique option for neuromodulation. This genetic modification of neurons is engineered by using light-responsive proteins named as opsins to realize light-based stimulations or inhibition. Light-sensitive proteins such as *Channelrhodopsin 2 (ChR2)* initiates action potential, whereas *Halorhodopsin (Halo)* triggers neuron inhibition, and *Archaeorhodopsins (Arch)* prompts action potential inhibition. Upon light stimulation (blue), the ChR2 depolarizes the targeted neuron by opening the cation channel. Then again, upon yellow light illumination, another protein NpHR (Halo) results in an inhibitory effect due to injection of chloride ions into the neuron. Optogenetics enables cell specificity [110] as this method can inhibit [111], [112] and/or stimulate cells [113] and capable of treating brain diseases such as nerve injury [114] and neuropathic pain [115] to name a few. In addition, light-based neural modulations can be carried out effortlessly as it is free of electromagnetic interference. Furthermore, as compared to electrical stimulation, light-based stimulation can be confined to only genetically modified neurons, as illustrated in Fig. 6. As a result, optogenetics ensures immaculate manoeuvre of neural modulations, which has also been another key challenge. However, optogenetics is still in the development phase, mostly tested on animals, and requires genetic modifications.

Simultaneous capability of neural recording and stimulation is actively pursued to ensure versatile and long-term recording and stimulation implantable neural systems [116], [117].

TABLE I
NOVEL NEURAL PROBE TECHNOLOGIES

Emerging Technology	Scale and Features	Long-term chronic reliability	Functionalities	Reference (s)
Neurotassels	1024 microelectrode filaments, each with a cross-sectional footprint of $3 \times 1.5 \mu\text{m}^2$	3-6 weeks after implantation	Neural activity recordings for behavioral training in mice. Can be integrated with optical fiber for simultaneous stimulation and recording.	[71], 2019
Neuropixels	Silicon Probe, 960 channels on a single, 10-mm long, non-tapered shank with $70 \times 20\text{-}\mu\text{m}$ cross-section	Up to 60 days	Simultaneous neural activity recording from multiple brain regions to address the relationship of behavior to activity distributed across the brain	[49], 2017
Neurogrid	120–256 channels; electrodes are $10 \times 10 \mu\text{m}^2$ with $30\text{-}\mu\text{m}$ interelectrode spacing, use of PEDOT: PSS as interface material	10 days	Recording large-scale neural activities such as LFP and AP in the dorsal cortical surface	[102], 2015
NeuE (Mesh Electronics)	$\sim 0.9 \mu\text{m}$ in total thickness flexible polymer probe, comparable to Axon	Up to 3 months	Stable single-neuron recording of individual cells and holds promise as a transplantation-free regenerative medicine.	[81], 2019
Multifunctional probe	Silicon probe, electrical recording, optical stimulation, fluidic delivery, $128 \mu\text{m}$ in width $40 \mu\text{m}$ in thickness each shank	2 weeks	Can be used in complex brain circuit studies where three or more brain regions are connected	[50], 2019
e-Dura mater	Elastomeric substrate (PDMS), $120 \mu\text{m}$ in thickness, stretchable, multifunctional	6 weeks	Rehabilitation and therapeutic application for spinal cord injury	[72], 2015
MRI compatible flexible probe	CNT fiber based, fiber minimum diameter $5 \mu\text{m}$.	6-12 weeks	Soft and MRI compatible neural electrodes enable stable chronic electrophysiological measurements and anatomical or functional MRI studies of the entire brain	[99], 2019
3D probe	Silicon based, 1024 electrodes per 0.6mm^3	Possible but not evaluated	Recording of coordinated activity of large populations of neurons distributed across the brain	[51], 2016

MRI-Magnetic Resonance Imaging; LFP-Local Field Potential; AP- Action Potential.

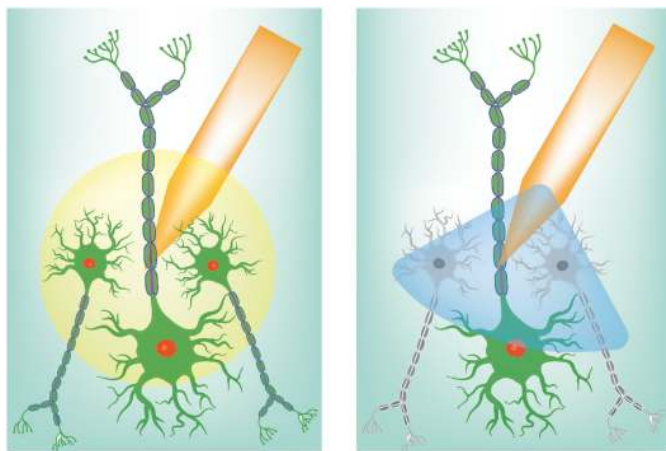

Fig. 6. (Left) Electrical stimulation will excite all the neurons in a given region without sparing the non-targeted neurons. (Right) Optogenetic stimulation excite only genetically engineered neurons (using protein ChR2, depicted green neuron) excluding the non-targeted neurons, shown as grey neuron.

Such closed-loop neuromodulation system, in general, may include a power management system, recording electrodes, signal processing core, electrophysiology unit as well as stimulation system that can be either optogenetics or electrical as shown in Fig. 7. Optogenetics modulation offers less interference with

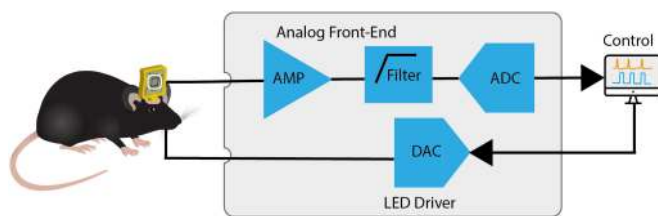

Fig. 7. Schematic of a head stage closed loop neural modulation system.

simultaneous electrical recordings and optical stimulation than does electrical stimulation. However, a typical complication associated with electrical recordings and optogenetics is undesirable electrodes' response to the light [118]. This is due to the fact that in case the light strikes a metal electrode, it introduces an artefact due to the photovoltaic or Becquerel effect. The amplitude of these artefacts can be significant and long-lasting, causing potential data loss and/or distorts recorded neuronal signal. Therefore, electrode recordings during optogenetic stimulation are complicated for neural modulation. Recently, several artefact-free closed-loop battery-powered optogenetics/opto-electrophysiology systems have been introduced [119]–[124]. Some of the strategies that can reduce light artefacts are using graphene electrodes [119], covering the electrode with opaque

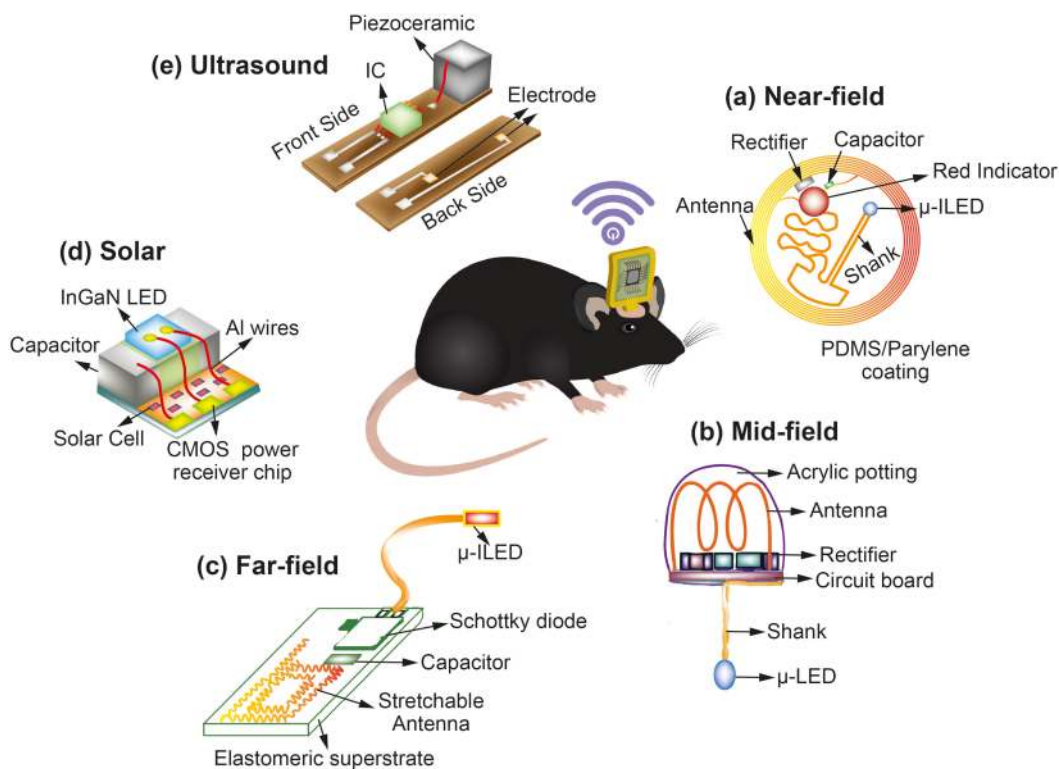

Fig. 8. Numerous wireless solutions demonstrate the various scale of the implants including electromagnetic (near-field, mid-field, and far-field), solar, and ultrasound.

polyimide [120], or reducing photopotential [121]. Additionally, the battery-powered head-mounted optogenetics closed-loop devices permits majority of the system to stay outside the body. As a result, these systems provide the options for modification to perceive diverse multi-modal platforms with less restrictions on size and scale, powering methods, and electronic designs. Nevertheless, due to the relative bulkiness and size, this method limits its application for chronic implantation and is more susceptible to physical injury due to the external mass. In the next section, fully implantable wireless neural devices will be discussed.

IV. FULLY IMPLANTABLE WIRELESS NEURAL DEVICE

Traditional methods for optogenetics depend on stiff and battery-powered systems to transfer power to the brain from outside power supplies [125]. Such method harms the normal tissue environment due to the micro-motion introduced by these systems. For optogenetics, recent researches have focused on reducing mechanical stress and damage of tissue by minimizing implant size by applying SU-8 waveguides coupled with small laser diode and integrated silicon devices based on microscale inorganic light-emitting diodes (μ -LEDs) [126]–[129]. Nonetheless, their rigid mechanisms still misaligned with the soft tissue of the brain [130], which institutes substantial tissue trauma and swelling as time goes by, as described before. Other approaches to address this issue made use of biocompatible flexible polymers [131], [132], which also rely on wired or tethered systems with external sources and cause excessive mechanical

pressure and continuous annoyance in freely moving rodents by obstructing their normal behaviour. In recent years, thanks to the wireless power engineering, significant advancements have been achieved by integrating wireless methodologies to enable chronic in vivo implantable neural device in freely moving animals. Ultrasonic or induction based power supplies for signal and/or power communication [88], [133]–[136] are some of the most commonly used techniques for wireless interface. Integrating these wireless implantable devices with multichannel and/or optofluidic channel, while challenging, may enable simultaneous neural recording and stimulation or drug delivery. These elusive combinational wireless technologies will enable to study long-term progression and recognize future therapeutic interventions for psychiatric and neurological conditions such as schizophrenia or Parkinson's disease. Although relatively new, there is a recent surge in developing wireless implantable neural system and the potential benefits of wireless devices are tremendous. In the following subsection, progress in wireless system for both conventional electrical stimulation and optogenetics will be discussed.

A subset of wireless solutions for development of an implantable neural device will be explored, as illustrated in Fig. 8. These wireless technologies mainly include ultrasound, electromagnetic, and solar. The thought for choosing the suitable wireless innovation incorporates propagation characteristics, implant size, and power adequacy. In view of this, we give a correlation in Fig. 9 between the diverse wireless power transfer schemes.

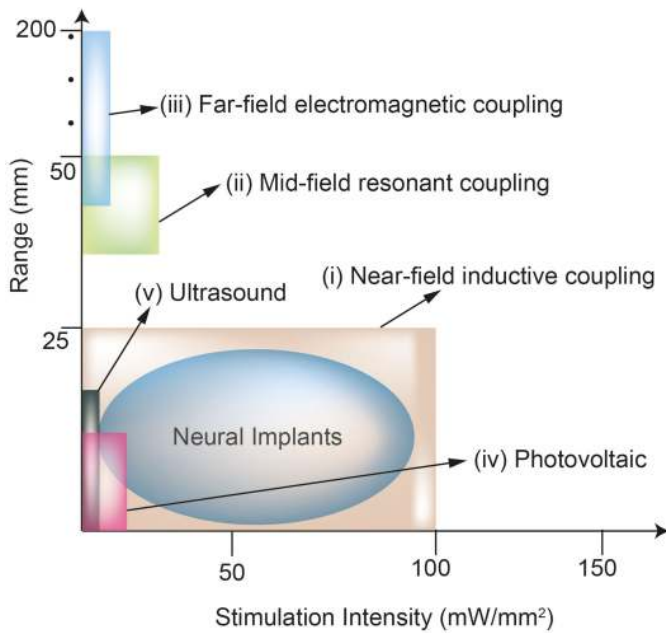

Fig. 9. Comparison among different wireless power transfer scheme in terms of stimulation intensity and power transfer distance.

A. Electromagnetic Near-Field Based Wireless System

Proposed device in [137] consists of a spiral coil for wireless power, impedance matching capacitor, a chip mounted on the surface for control, a rectification circuit, and a μ -LED to realize the optogenetic stimulation (Fig. 8(a)). PDMS and Parylene C insulations were also provided to prevent shorting between the wireless receiving circuit and subdermal fluid. Near field communication (NFC \sim 13.56 MHz), based on the electromagnetic induction is the underlying principle of the energy harvesting circuit. The coil occupies a total volume of $9.8 \times 60 \times 18 \mu\text{m}^3$. For a successful operation, this wireless system requires transmitter with loop antennas aligned properly to the receiver circuit implanted in the brain to transfer power efficiently. Applying the NFC method for optogenetic stimulation and wireless power enables an in-expensive and comparatively simple way regarding wireless implantable neural systems. In addition, this methodology of wireless powering utilizes low-frequency near-field domain and generates less specific absorption rate in tested animals in comparison with far-field systems and provides smaller loss than high-frequency band. Although the size of the implanted device is smaller than other related designs for neural modulations, larger coil size (diameter of 9.8 mm) limits the implantation of multiple devices.

B. Electromagnetic Mid-Field Based Wireless System

To stimulate the spinal cord, brain, and peripheral nerve, a completely implantable wireless system based on optogenetics is presented by Ada poon *et al.* [134]. They made use of evanescent signals emanating from a metallic resonant cavity, and mice are positioned on the top of this resonator to receive power wirelessly to steer a blue LED. In their previous research they demonstrated that due to the difference in dielectric properties

between the tissue and free space, permits electromagnetic energy to be confined to the mice body. This method also alleviates the requirement of an additional tracking mechanism generally applied to assure consistent wireless power. The wireless power transmission was composed of a wireless power receiving coil (diameter 1.6 mm), rectifier, circuit board and the metallic RF cavity resonator (Aluminium, 21 cm diameter, 15 cm height) resonated at midfield band of 1.5 GHz. The entire implant including a blue μ -LED is demonstrated in Fig. 8(b) and measures about 20–50 mg and accommodates a volume of 10–25 mm^3 . For optogenetics excitation, the optimum efficiency of the μ -LED (light emitted/power input) is 19%. This level of power is more than enough to radiate the optical density of 1–20 mW/mm^2 for optogenetics stimulation. Due to the stiff structure and as this wireless operations needs a big metallic resonator that transmits radio-frequency power to supervise the implant, this method applicable in a regulated lab scenario and not for chronic cases.

C. Electromagnetic Far-field Based Wireless Power System

As compared to the stiff implant of Montgomery *et al.* [134], advancement in soft and flexible electronics empowered to develop an energy harvesting system, which is stretchable, flexible (PDMS encapsulated), and fully implantable [88], as shown in Fig. 8(c). The implant consists of four key parts: a power harvester, rectifier circuit along with a voltage multiplier, and a very small 470 nm LED. PDMS encapsulation of the implant ensures not only protection from the adjacent tissues but also forms a physical and mechanical alliance with the tissue. Due to smaller size ($6 \times 3.8 \times 0.7 \text{ mm}^3$) and lightweight (16 mg), the device is available to implant subdermally in numerous crucial areas of peripheral and central nervous systems to support *in vivo* optogenetics. By reducing the thickness of the PDMS encapsulation, the implant can achieve lighter, slimmer, and bendable profile to facilitate the biointegration with tissue. A stretchable antenna having a miniaturized surface area of $3 \times 3 \text{ mm}^2$, resonating at 2.3 GHz with a 200 MHz bandwidth, is a key component of this device to harvest the RF energy. Due to the significant higher bandwidth than the traditional patch antenna, this type of receiver antenna can enhance the energy harvesting efficiency. The transmitted RF signal is generated by another antenna from the base station. Identical RF signals are applied to energy harvesting as well as control signalling to power the LED. Despite the unique characteristics, the resonant frequency of the stretchable antenna may change due to deformity caused by the animal motions, and therefore, requires further optimization. Furthermore, the footprint of the device is too big to recognize a large-scale distributed optogenetics system. Recently, this work is further developed to a thinner and lighter device to steer up to four channels using a modified antenna [138].

D. Solar-Powered Wireless System

Photovoltaic energy harvesting from light [139]–[142] is another enthralling tool to wirelessly power the implantable devices. In [139], to replace the batteries for uninterrupted functioning of implants, an implantable device made of tiny, thin solar cells (gallium arsenide, 5 mg) along with a wireless

logical control module based on RF signal to activate μ -LEDs, was introduced and depicted in Fig. 8(d). The wireless control of this device was enabled by using a rectifier circuit that converts the RF signal to direct current to drive a low-power logic circuit, which is integrated with solar cells and LEDs. As compared to the identical system without photovoltaics, this combination of solar and RF wireless system improves the wireless power transfer range capability (~ 3 m) and simultaneously lower the RF power requirements substantially (almost by a factor of 10). As a result, this system significantly reduces electromagnetic exposure to animals as well as enabling free, natural behaviour in animals. This is a head-mounted wireless system, where the solar cells are placed on top of the head of a rat.

In another work [143], a photovoltaic wireless power transfer system based on CMOS (complementary metal-oxide semiconductor) applicable for tiny (≤ 1 – 2 mm) implantable electronic devices is introduced. To integrate the photovoltaic cells, the implant contains a CMOS power receiver chip having surface area of 1.25×1.25 mm². By using the infrared light, this implant successfully powered a blue LED. Then, the CMOS chip as well as a few off-chip parts were integrated to develop an implantable optogenetics device (1 mm³). However, light sources nature, proximity, and direction limits the solar cells wireless powering ability for implantable neural devices.

F. Ultrasound Based Wireless System

Among others, Maharbiz *et al.* studied the ultrasound based wireless neural implants as evidenced through their Neural Dust [144] and Stim Dust [145]. In one of the most recent studies [133], they developed a 0.8 mm³ ultrasonically powered miniaturized wireless neural implant. The size of the recording IC is 0.25 mm² only and for both power and data transmission a single piezoceramic resonator was used, as pictured in Fig. 8(e). This small device with wireless power capability can minimize tissue damage, scar formation, and neuroinflammatory response. The device can operate at a depth of 5 cm, allowing neural recording from the deep brain regions and most peripheral nerves. The implants achieved simultaneous power and data delivery with an inexpensive unfocused single-element transducer placed externally. This allows for maximized working depth and optimum frequency thereby improving the spatiotemporal resolution in a distributed recording environment.

Another work, STARDUST project envisions the implementation of an implant, which is going to be used primarily for optogenetics, and later as a recording device with a drug-delivery system. The first version of this optogenetic device (i.e., dust) to be used only for optogenetics has been fabricated and tested, which includes a PZT cube of $560 \times 560 \times 490$ μ m³, a μ -LED of $280 \times 180 \times 100$ μ m³ and an active rectifier with the size of 300×300 μ m² [129]. The vision of this project is to develop a Dust with the same dimensions for other applications including recording and drug-delivery leading a full system in micro-scale dimension for freely moving animals for Parkinson's disease treatment. Ultrasound based wireless systems enables low signal attenuation in biological tissue, minimized geometry, and can be used safely with human. However, complicated circuitry and

complexity in addressing the ultrasound frequency remain the two main bottlenecks. In addition, ultrasound-based wireless systems have low data rate (e.g., Kb/s), has a signal is greatly attenuated by the skull and needs an intermediate transceiver based on electromagnetic coupling beneath the skull.

So far, some of the most common forms of wireless power system for implantable neural devices are discussed and summarized in Table II. Apart from these, there are emerging technologies which combines multiple stimulation options and optofluidic channel [146], [147], uses innovative approach to achieve an ultra-miniaturized implant [148], introduces scalable and distributed wireless neural platform [149], [150], wireless optoelectronic photometer for dynamic mapping of the brain [151], simultaneous multichannel optogenetics stimulation and multichannel electrical recording system [152].

Fig. 9 shows the comparison among different power transfer schemes with respect to the power transfer range to achieve the power requirement for the neural implants. In terms of device miniaturization and signal propagation, ultrasound allows better wireless solution than the solar and electromagnetic based technologies. To add more, the ultrasound energy has low propagation loss in biological tissues. In accordance with to FDA (Food and Drug Administration), the ultrasound exposure to the human tissue is limited to 720 mW/cm², whilst RF is 10 mW/cm². Manufacturing complexity is the main obstacle of ultrasound technology. On the other hand, with increasing frequency, the antenna size can be miniaturized thus application of electromagnetic approaches more appealing for device miniaturization. As it is expected that the next-generation implants will require less power, lower size and form factor, the resonant coupling based on mid-field and far-field based wireless power transfer would be beneficial. In addition to power transfer, simultaneous data transmission is another crucial parameter to remotely control and monitor the activities. Among all power transfer systems, only the ultrasound and near-field methods have the capability to enable simultaneous power and data transfer. As a result, the near-field inductive-coupling scheme still can meet the power requirements by the most commonly used implantable devices. In conclusion, implantable neural device design must consider specific types of power transfer schemes depending on the application for superior performance.

In one of the most recent studies, a fully implantable wireless closed loop optogenetics system has been introduced that can monitor and control bladder function through a smart device [153]. The schematic of this closed loop system is given in Fig. 10. The authors use a soft elastomeric material (PDMS), which shows negligible inflammatory response after 7 days of implantation. The implant/smart device user interface was developed though a software using XCode to log the recording data and to provide systematic stimulations. Such system can be easily adapted to address several application scenarios beyond the bladder control. Furthermore, the sensing module could be modified to associate different biophysical (e.g., temperature, pressure) and/or biochemical (e.g., metabolites, proteins) sensors, as well as can be integrated with numerous actuators (e.g., pharmacological) to allow the appropriate modulation, all utilizing control given by the wireless module through developing

TABLE II
COMPARISON OF THE RECENT FULLY IMPLANTABLE WIRELESS POWERING TECHNOLOGIES

Powering Scheme	Scale and Features	Frequency	Encapsulation	Range	SAR/Heating	Reference (s)
Near-Field	Implant Diameter: 9.8mm Thickness < 1.3 mm Weight~ 30 mg	13.56 MHz	Parylene C	~0.1 m	<20 mW/kg	[137], 2017
Mid-Field	Implant volume: 10-25 mm ³ Weight: 20-50 mg	1.5 GHz	Light-cure acrylic	~0.03 m	<1 °C	[134], 2015
Far-Field	Implant size: 0.7 mm × 3.8 mm × 6 mm Weight: 16 mg	2.3 GHz	PDMS	~0.2 m	~69 mW/kg	[88], 2015
Solar Powered	Implant size: 1-1.7 mm ³ Weight: 2.3 mg	N/A	N/A	N/A	N/A	[143], 2018
Ultrasound	Implant size: 0.8 mm ³	1.78 MHz	Parylene C	~0.03-0.05 m	N/A	[133], 2019

N/A: Not Applicable.

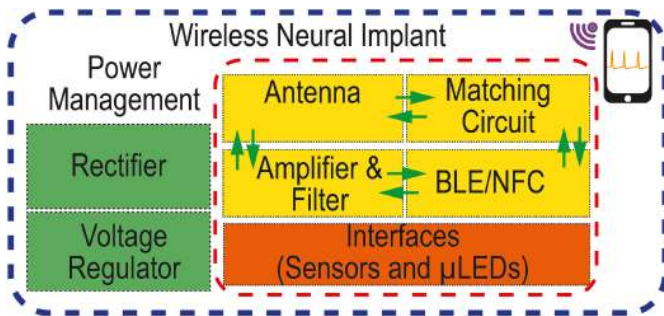

Fig. 10. Schematic of a futuristic fully wireless implantable neural system that can be interfaced through a smart device for versatile neural modulation control.

a proper user interface. These wireless closed loop technologies may act as a platform to realize the futuristic vision by integrating the wireless optogenetics system into smart healthcare using mobile and electronic technology for better diagnosis of the brain diseases, improved treatment, and enhanced quality of lives.

V. CONCLUSION

Research on implantable neural device/tissue interface is one of the most fundamental components for neural engineering. The discussion portrayed here represents state-of-the-art strategies for implantable neural probe that are now available. While certainly enchanting, such device strategies introduce additional demands on device durability and material stability due to mechanical mismatch and neuroinflammatory response. One of the most significant challenges are making these devices scale down to the dimension of a typical neuron and interfacing them to particular types of neuron. A combinatorial approach will require to realize an ideal neural device, which incorporates advanced materials and biomimetics as well as fabrication to seamlessly integrate with the nervous system for proper biointegration. On the other hand, communication and powering these devices emerge another challenge while considering the side effects that

can occur to the brain. As a result, newly developed wireless technologies allow several benefits over their head-mounted or tethered predecessors. Realizing the development of wireless implants at the nano/microscale could be a significant step forward to future neurotechnologies for connecting engineering to medicine that addresses important challenges for treating neurological diseases.

REFERENCES

- [1] N. K. Logothetis, "What we can do and what we cannot do with fMRI," *Nature*, vol. 453, no. 7197, pp. 869–878, Jun. 2008.
- [2] M. Lee, H. J. Shim, C. Choi, and D. H. Kim, "Soft high-resolution neural interfacing probes: Materials and design approaches," *Nano. Lett.*, vol. 19, no. 5, pp. 2741–2749, May 2019.
- [3] A. J. Casson, S. Smith, J. S. Duncan, and E. Rodriguez-Villegas, "Wearable EEG: What is it, why is it needed and what does it entail?," in *Proc. 30th Annu. Int. Conf. IEEE Eng. Med. Bio. Soc.*, 2008, vol. 1–8, pp. 5867–5870.
- [4] X. Zhou, Q. Li, S. Kilsgaard, F. Moradi, S. L. Kappel, and P. Kidmose, "A wearable Ear-EEG recording system based on dry-contact active electrodes," in *Proc. IEEE Symp. Vlsi Circuits*, 2016, pp. 1–2.
- [5] G. S. Hong and C. M. Lieber, "Novel electrode technologies for neural recordings," *Nat. Rev. Neurosci.*, vol. 20, no. 6, pp. 376–376, Jun. 2019.
- [6] P. K. Campbell, K. E. Jones, R. J. Huber, K. W. Horch, and R. A. Normann, "A silicon-based, three-dimensional neural interface: Manufacturing processes for an intracortical electrode array," *IEEE Trans. Biomed. Eng.*, vol. 38, no. 8, pp. 758–768, Aug. 1991.
- [7] A. Jackson and J. B. Zimmermann, "Neural interfaces for the brain and spinal cord-restoring motor function," *Nat. Rev. Neurol.*, vol. 8, no. 12, pp. 690–699, Dec. 2012.
- [8] A. Kan, "Improving speech recognition in bilateral cochlear implant users by listening with the better ear," *Trends Hear.*, vol. 22, Apr. 2018, Art. no. 2331216518772963.
- [9] M. L. Kringelbach, N. Jenkinson, S. L. F. Owen, and T. Z. Aziz, "Translational principles of deep brain stimulation," *Nat. Rev. Neurosci.*, vol. 8, no. 8, pp. 623–635, Aug. 2007.
- [10] W. C. Stacey and B. Litt, "Technology insight: Neuroengineering and epilepsy - Designing devices for seizure control," *Nat. Clin. Pract. Neurol.*, vol. 4, no. 4, pp. 190–201, Apr. 2008.
- [11] E. Zrenner, "Will retinal implants restore vision?," *Science*, vol. 295, no. 5557, pp. 1022–1025, Feb. 2002.
- [12] T. D. Y. Kozai *et al.*, "Mechanical failure modes of chronically implanted planar silicon-based neural probes for laminar recording," *Biomaterials*, vol. 37, pp. 25–39, Jan. 2015.

- [13] P. Moshayedi *et al.*, "The relationship between glial cell mechanosensitivity and foreign body reactions in the central nervous system," *Biomaterials*, vol. 35, no. 13, pp. 3919–3925, Apr. 2014.
- [14] V. S. Polikov, P. A. Tresco, and W. M. Reichert, "Response of brain tissue to chronically implanted neural electrodes," *J. Neurosci. Methods*, vol. 148, no. 1, pp. 1–18, Oct. 2005.
- [15] S. Balasubramaniam, S. A. Wirdatmadja, M. T. Barros, Y. Koucheryavy, M. Stachowiak, and J. M. Jornet, "Wireless communications for optogenetics-based brain stimulation: Present technology and future challenges," *IEEE Commun. Mag.*, vol. 56, no. 7, pp. 218–224, Jul. 2018.
- [16] P. Gutruf and J. A. Rogers, "Implantable, wireless device platforms for neuroscience research," *Current Opinion Neurobiol.*, vol. 50, pp. 42–49, Jun. 2018.
- [17] R. Jegadeesan, S. Nag, K. Agarwal, N. V. Thakor, and Y. X. Guo, "Enabling wireless powering and telemetry for peripheral nerve implants," *IEEE J. Biomed. Healthcare*, vol. 19, no. 3, pp. 958–970, May 2015.
- [18] R. Qazi, C. Y. Kim, S. H. Byun, and J. W. Jeong, "Microscale inorganic LED based wireless neural systems for chronic in vivo optogenetics," *Frontiers Neuroscience*, vol. 12, p. 764, Oct. 2018.
- [19] H. Grundfest and B. Campbell, "Origin, conduction and termination of impulses in the dorsal spino-cerebellar tract of cats," *J. Neurophysiol.*, vol. 5, no. 4, pp. 275–294, Jul. 1942.
- [20] H. Grundfest, R. W. Sengstaken, W. H. Oettinger, and R. W. Gurry, "Stainless steel micro-needle electrodes made by electrolytic pointing," *Rev. Sci. Instrum.*, vol. 21, no. 4, pp. 360–361, 1950.
- [21] J. J. Pancrazio and P. H. Peckham, "Neuroprosthetic devices: How far are we from recovering movement in paralyzed patients?," *Expert Rev. Neurotherapeutics*, vol. 9, no. 4, pp. 427–430, Apr. 2009.
- [22] B. Renshaw, A. Forbes, and B. R. Morison, "Activity of isocortex and hippocampus: Electrical studies with micro-electrodes," *J. Neurophysiol.*, vol. 3, no. 1, pp. 74–105, Jan. 1940.
- [23] G. Pfurtscheller and F. H. L. da Silva, "Event-related EEG/MEG synchronization and desynchronization: Basic principles," *Clin. Neurophysiol.*, vol. 110, no. 11, pp. 1842–1857, Nov. 1999.
- [24] K. Y. Kwon, B. Sirowatka, A. Weber, and W. Li, "Opto- μ ECoG Array: A hybrid neural interface with transparent μ ECoG electrode array and integrated LEDs for optogenetics," *IEEE Trans. Biomed. Circuits Syst.*, vol. 7, no. 5, pp. 593–600, Oct. 2013.
- [25] E. C. Leuthardt, G. Schalk, J. R. Wolpaw, J. G. Ojemann, and D. W. Moran, "A Brain-Computer Interface Using Electrocorticographic Signals In Humans," *J. Neural Eng.*, vol. 1, no. 2, pp. 63–71, Jun. 2004.
- [26] C. M. Lopez *et al.*, "A neural probe with up to 966 electrodes and up to 384 configurable channels in 0.13 μ m SOI CMOS," *IEEE Trans. Biomed. Circuits Syst.*, vol. 11, no. 3, pp. 510–522, Jun. 2017.
- [27] J. T. Robinson, M. Jorgolli, A. K. Shalek, M. H. Yoon, R. S. Gertner, and H. Park, "Vertical nanowire electrode arrays as a scalable platform for intracellular interfacing to neuronal circuits," *Nat. Nanotechnol.*, vol. 7, no. 3, pp. 180–184, Mar. 2012.
- [28] C. Babiloni *et al.*, "Cortical EEG alpha rhythms reflect task-specific somatosensory and motor interactions in humans," *Clin. Neurophysiol.*, vol. 125, no. 10, pp. 1936–1945, Oct. 2014.
- [29] M. Kutas and K. D. Federmeier, "Electrophysiology reveals semantic memory use in language comprehension," *Trends Cogn. Sci.*, vol. 4, no. 12, pp. 463–470, Dec. 2000.
- [30] J. J. S. Norton *et al.*, "Soft, curved electrode systems capable of integration on the auricle as a persistent brain-computer interface," *Proc. Nat. Acad. Sci.*, vol. 112, no. 13, pp. 3920–3925, Mar. 2015.
- [31] S. J. M. Smith, "EEG in the diagnosis, classification, and management of patients with epilepsy," *J. Neurol. Neurosurgery Psychiatry*, vol. 76, pp. 2–7, Jun. 2005.
- [32] N. Birbaumer, "Brain-computer-interface research: Coming of age," *Clin. Neurophysiol.*, vol. 117, no. 3, pp. 479–483, Mar. 2006.
- [33] M. A. Kramer and A. J. Szeri, "Quantitative approximation of the cortical surface potential from eeg and ecog measurements," *IEEE Trans. Biomed. Eng.*, vol. 51, no. 8, pp. 1358–1365, Aug. 2004.
- [34] M. Wang, G. J. Mi, D. Shi, N. Bassous, D. Hickey, and T. J. Webster, "Nanotechnology and nanomaterials for improving neural interfaces," *Adv. Functional Mater.*, vol. 28, no. 12, Mar. 2018, Art. no. 1700905.
- [35] J. Rivnay, H. L. Wang, L. Fenno, K. Deisseroth, and G. G. Malliaras, "Next-generation probes, particles, and proteins for neural interfacing," *Sci. Adv.*, vol. 3, no. 6, Jun. 2017, Art. no. e1601649.
- [36] M. Lee, H. J. Shim, C. Choi, and D. H. Kim, "Soft high-resolution neural interfacing probes: Materials and design approaches," *Nano Lett.*, vol. 19, no. 5, pp. 2741–2749, May 2019.
- [37] B. Fan and W. Li, "Miniaturized optogenetic neural implants: A review," *Lab Chip*, vol. 15, no. 19, pp. 3838–3855, 2015.
- [38] T. I. Kim *et al.*, "Injectable, cellular-scale optoelectronics with applications for wireless optogenetics," *Science*, vol. 340, no. 6129, pp. 211–216, Apr. 2013.
- [39] M. M. Maharbiz, R. Muller, E. Alon, J. M. Rabaey, and J. M. Carmena, "Reliable next-generation cortical interfaces for chronic brain-machine interfaces and neuroscience," *Proc. IEEE*, vol. 105, no. 1, pp. 73–82, Jan. 2017.
- [40] S. M. Won, E. M. Song, J. N. Zhao, J. H. Li, J. Rivnay, and J. A. Rogers, "Recent advances in materials, devices, and systems for neural interfaces," *Adv. Mater.*, vol. 30, no. 30, Jul. 2018, Art. no. 1800534.
- [41] S. W. Hwang *et al.*, "A physically transient form of silicon electronics," *Science*, vol. 337, no. 6102, pp. 1640–1644, Sep. 2012.
- [42] J. W. Jeong, G. Shin, S. Il Park, K. J. Yu, L. Z. Xu, and J. A. Rogers, "Soft materials in neuroengineering for hard problems in neuroscience," *Neuron*, vol. 86, no. 1, pp. 175–186, Apr. 2015.
- [43] M. E. J. Obien, K. Deligkaris, T. Bullmann, D. J. Bakkum, and U. Frey, "Revealing neuronal function through microelectrode array recordings," *Frontiers Neurosci.*, vol. 8, p. 423, Jan. 2015.
- [44] M. Jorfi, J. L. Skousen, C. Weder, and J. R. Capadona, "Progress towards biocompatible intracortical microelectrodes for neural interfacing applications," *J. Neural Eng.*, vol. 12, no. 1, Feb. 2015, Art. no. 011001.
- [45] S. Venkatraman *et al.*, "In vitro and in vivo evaluation of PEDOT microelectrodes for neural stimulation and recording," *IEEE Trans. Neural Sys. Rehabil.*, vol. 19, no. 3, pp. 307–316, Jun. 2011.
- [46] K. Scholten and E. Meng, "Materials for microfabricated implantable devices: A review," *Lab Chip*, vol. 15, no. 22, pp. 4256–4272, 2015.
- [47] G. H. Kim *et al.*, "Recent progress on microelectrodes in neural interfaces," *Materials*, vol. 11, no. 10, p. 1995, Oct. 2018.
- [48] K. D. Wise, "Silicon microsystems for neuroscience and neural prostheses," *IEEE Eng. Med. Biol. Mag.*, vol. 24, no. 5, pp. 22–29, Sep./Oct. 2005.
- [49] J. J. Jun *et al.*, "Fully integrated silicon probes for high-density recording of neural activity," *Nature*, vol. 551, no. 7679, pp. 232–236, Nov. 2017.
- [50] H. Shin *et al.*, "Multifunctional multi-shank neural probe for investigating and modulating long-range neural circuits in vivo," *Nat. Commun.*, vol. 10, Aug. 2019, Art. no. 3777.
- [51] G. Rios, E. V. Lubenov, D. Chi, M. L. Roukes, and A. G. Siapas, "Nanofabricated neural probes for dense 3-D recordings of brain activity," *Nano Lett.*, vol. 16, no. 11, pp. 6857–6862, Nov. 2016.
- [52] P. K. Campbell, K. E. Jones, R. J. Huber, K. W. Horch, and R. A. Normann, "A silicon-based, three-dimensional neural interface: Manufacturing processes for an intracortical electrode array," *IEEE Trans. Biomed. Eng.*, vol. 38, no. 8, pp. 758–768, Aug. 1991.
- [53] D. Prodanov and J. Delbeke, "Mechanical and biological interactions of implants with the brain and their impact on implant design," *Frontiers Neuroscience*, vol. 10, p. 11, Feb. 2016.
- [54] K. Woeppel, Q. Yang, and X. T. Cui, "Recent advances in neural electrode-tissue interfaces," *Current Opinion Biomed. Eng.*, vol. 4, pp. 21–31, Dec. 2017.
- [55] R. Chen, A. Canales, and P. Anikeeva, "Neural recording and modulation technologies," *Nature Rev. Mater.*, vol. 2, no. 2, Feb. 2017, Art. no. 16093.
- [56] A. Prochazka, "Neurophysiology and neural engineering: A review," *J. Neurophysiol.*, vol. 118, no. 2, pp. 1292–1309, Aug. 2017.
- [57] R. Caldwell *et al.*, "Neural electrode resilience against dielectric damage may be improved by use of highly doped silicon as a conductive material," *J. Neurosci. Method*, vol. 293, pp. 210–225, Jan. 2018.
- [58] S. F. Lempka, M. D. Johnson, M. A. Moffitt, K. J. Otto, D. R. Kipke, and C. C. McIntyre, "Theoretical analysis of intracortical microelectrode recordings," *J. Neural Eng.*, vol. 8, no. 4, Aug. 2011, Art. no. 045006.
- [59] E. Patrick, M. E. Orazem, J. C. Sanchez, and T. Nishida, "Corrosion of tungsten microelectrodes used in neural recording applications," *J. Neurosci. Method*, vol. 198, no. 2, pp. 158–171, Jun. 2011.
- [60] L. A. Geddes and R. Roeder, "Criteria for the selection of materials for implanted electrodes," *Ann. Biomed. Eng.*, vol. 31, no. 7, pp. 879–890, Jul. 2003.
- [61] D. Scaini and L. Ballerini, "Nanomaterials at the neural interface," *Current Opinion Neurobiol.*, vol. 50, pp. 50–55, Jun. 2018.
- [62] D. F. Williams, "On the mechanisms of biocompatibility," *Biomaterials*, vol. 29, no. 20, pp. 2941–2953, Jul. 2008.
- [63] S. P. Lacour, G. Courtine, and J. Guck, "Materials and technologies for soft implantable neuroprostheses," *Nature Rev. Mater.*, vol. 1, no. 10, Oct. 2016, Art. no. 16063.

- [64] D. A. Schwarz *et al.*, "Chronic, wireless recordings of large-scale brain activity in freely moving rhesus monkeys," *Nature Methods*, vol. 11, no. 6, pp. 670–676, Jun. 2014.
- [65] P. J. Rousche, D. S. Pellinen, D. P. Pivin, Jr., J. C. Williams, R. J. Vetter, and D. R. Kipke, "Flexible polyimide-based intracortical electrode arrays with bioactive capability," *IEEE Trans. Biomed. Eng.*, vol. 48, no. 3, pp. 361–371, Mar. 2001.
- [66] J. Liu *et al.*, "Syringe-injectable electronics," *Nature Nanotechnol.*, vol. 10, no. 7, pp. 629–636, Jul. 2015.
- [67] H. Lee, R. V. Bellamkonda, W. Sun, and M. E. Levenston, "Biomechanical analysis of silicon microelectrode-induced strain in the brain," *J. Neural Eng.*, vol. 2, no. 4, pp. 81–89, Dec. 2005.
- [68] T. D. Kozai *et al.*, "Ultrasmall implantable composite microelectrodes with bioactive surfaces for chronic neural interfaces," *Nature Mater.*, vol. 11, no. 12, pp. 1065–73, Dec. 2012.
- [69] T. M. Fu, G. Hong, R. D. Viveros, T. Zhou, and C. M. Lieber, "Highly scalable multichannel mesh electronics for stable chronic brain electrophysiology," *Proc. Nat. Acad. Sci.*, vol. 114, no. 47, pp. E10046–E10055, Nov. 2017.
- [70] W. J. Tyler, "The mechanobiology of brain function," *Nature Rev. Neurosci.*, vol. 13, no. 12, pp. 867–878, Dec. 2012.
- [71] S. Guan *et al.*, "Elastocapillary self-assembled neurotassels for stable neural activity recordings," *Sci. Adv.*, vol. 5, no. 3, Mar. 2019, Art. no. eaav2842.
- [72] I. R. Mineev *et al.*, "Biomaterials. Electronic dura mater for long-term multimodal neural interfaces," *Science*, vol. 347, no. 6218, pp. 159–163, Jan. 2015.
- [73] G. Guitchounts, J. E. Markowitz, W. A. Liberti, and T. J. Gardner, "A carbon-fiber electrode array for long-term neural recording," *J. Neural Eng.*, vol. 10, no. 4, Aug. 2013, Art. no. 046016.
- [74] J. Tanaka, K. Toku, M. Sakanaka, and N. Maeda, "Morphological differentiation of microglial cells in culture: Involvement of insoluble factors derived from astrocytes," *Neurosci. Res.*, vol. 34, no. 4, pp. 207–215, Sep. 1999.
- [75] F. Vitale *et al.*, "Biomimetic extracellular matrix coatings improve the chronic biocompatibility of microfabricated subdural microelectrode arrays," *PLoS One*, vol. 13, no. 11, 2018, Art. no. e0206137.
- [76] B. Wang, P. Yang, Y. Ding, H. Qi, Q. Gao, and C. Zhang, "Improvement of the biocompatibility and potential stability of chronically implanted electrodes incorporating coating cell membranes," *ACS Appl. Mater. Interfaces*, vol. 11, no. 9, pp. 8807–8817, Mar. 2019.
- [77] M. Kang *et al.*, "Subcellular neural probes from single-crystal gold nanowires," *ACS Nano*, vol. 8, no. 8, pp. 8182–8189, Aug. 2014.
- [78] T. D. Kozai *et al.*, "Chronic in vivo evaluation of PEDOT/CNT for stable neural recordings," *IEEE Trans. Biomed. Eng.*, vol. 63, no. 1, pp. 111–119, Jan. 2015.
- [79] L. Luan *et al.*, "Ultraflexible nanoelectronic probes form reliable, glial scar-free neural integration," *Sci. Adv.*, vol. 3, no. 2, Feb. 2017, Art. no. e1601966.
- [80] T. D. Y. Kozai *et al.*, "Ultrasmall implantable composite microelectrodes with bioactive surfaces for chronic neural interfaces," *Nature Mater.*, vol. 11, no. 12, pp. 1065–1073, 2012.
- [81] X. Yang *et al.*, "Bioinspired neuron-like electronics," *Nature Mater.*, vol. 18, no. 5, pp. 510–517, May 2019.
- [82] F. Vitale, S. R. Summerson, B. Aazhang, C. Kemere, and M. Pasquali, "Neural stimulation and recording with bidirectional, soft carbon nanotube fiber microelectrodes," *ACS Nano*, vol. 9, no. 4, pp. 4465–4474, 2015.
- [83] B. J. Kim *et al.*, "3D parylene sheath neural probe for chronic recordings," *J. Neural Eng.*, vol. 10, no. 4, Aug. 2013, Art. no. 045002.
- [84] A. J. Teo, A. Mishra, I. Park, Y.-J. Kim, W.-T. Park, and Y.-J. Yoon, "Polymeric Biomaterials for Medical Implants and Devices," *ACS Biomaterials Sci. Eng.*, vol. 2, no. 4, pp. 454–472, 2016.
- [85] Z. J. Du *et al.*, "Ultrasoft microwire neural electrodes improve chronic tissue integration," *Acta Biomaterials*, vol. 53, pp. 46–58, Apr. 2017.
- [86] L. Guo, M. Ma, N. Zhang, R. Langer, and D. G. Anderson, "Stretchable polymeric multielectrode array for conformal neural interfacing," *Adv. Mater.*, vol. 26, no. 9, pp. 1427–1433, Mar. 2014.
- [87] G. Liang, G. S. Givanasen, L. Xi, C. Tuthill, T. R. Nichols, and S. P. DeWeerth, "A PDMS-based integrated stretchable microelectrode array (Ismea) for neural and muscular surface interfacing," *IEEE Trans. Biomed. Circuits Syst.*, vol. 7, no. 1, pp. 1–10, Feb. 2013.
- [88] S. I. Park *et al.*, "Soft, stretchable, fully implantable miniaturized optoelectronic systems for wireless optogenetics," *Nature Biotechnol.*, vol. 33, no. 12, pp. 1280–1286, Dec. 2015.
- [89] F. Wu, L. W. Tien, F. Chen, J. D. Berke, D. L. Kaplan, and E. Yoon, "Silk-backed structural optimization of high-density flexible intracortical neural probes," *J. Microelectromech. Syst.*, vol. 24, no. 1, pp. 62–69, 2014.
- [90] T. D. Kozai *et al.*, "Chronic tissue response to carboxymethyl cellulose based dissolvable insertion needle for ultra-small neural probes," *Biomaterials*, vol. 35, no. 34, pp. 9255–9568, Nov. 2014.
- [91] S. H. Felix *et al.*, "Insertion of flexible neural probes using rigid stiffeners attached with biodegradable adhesive," *JOVE-J VIS EXP*, no. 79, 2013, Art. no. e50609.
- [92] I. D. Dryg, M. P. Ward, K. Y. Qing, H. Mei, J. E. Schaffer, and P. P. Irazoqui, "Magnetically inserted neural electrodes: Tissue response and functional lifetime," *IEEE Trans. Neural Syst. Rehabil. Eng.*, vol. 23, no. 4, pp. 562–571, Jul. 2015.
- [93] H. Fang *et al.*, "Ulthra-thin, transferred layers of thermally grown silicon dioxide as biofluid barriers for biointegrated flexible electronic systems," *Proc. Nat. Acad. Sci.*, vol. 113, no. 42, pp. 11682–11687, 2016.
- [94] J. Xu *et al.*, "Highly stretchable polymer semiconductor films through the nanoconfinement effect," *Science*, vol. 355, no. 6320, pp. 59–64, 2017.
- [95] U. A. Aregueta-Robles, A. J. Woolley, L. A. Poole-Warren, N. H. Lovell, and R. A. Green, "Organic electrode coatings for next-generation neural interfaces," *Frontiers Neuroeng.*, vol. 7, no. 15, pp. 1–18, 2014.
- [96] E. W. Keefer, B. R. Botterman, M. I. Romero, A. F. Rossi, and G. W. Gross, "Carbon nanotube coating improves neuronal recordings," *Nature Nanotechnol.*, vol. 3, no. 7, pp. 434–439, Jul. 2008.
- [97] D. Kuzum *et al.*, "Transparent and flexible low noise graphene electrodes for simultaneous electrophysiology and neuroimaging," *Nature Commun.*, vol. 5, Oct. 2014, Art. no. 5259.
- [98] X. Luo, C. L. Weaver, D. D. Zhou, R. Greenberg, and X. T. Cui, "Highly stable carbon nanotube doped poly(3,4-ethylenedioxythiophene) for chronic neural stimulation," *Biomaterials*, vol. 32, no. 24, pp. 5551–5557, Aug. 2011.
- [99] L. L. Lu *et al.*, "Soft and MRI compatible neural electrodes from carbon nanotube fibers," *Nano Lett.*, vol. 19, no. 3, pp. 1577–1586, Mar. 2019.
- [100] P. Fattahi, G. Yang, G. Kim, and M. R. Abidian, "A review of organic and inorganic biomaterials for neural interfaces," *Adv. Mater.*, vol. 26, no. 12, pp. 1846–1885, Mar. 2014.
- [101] R. Green and M. R. Abidian, "Conducting polymers for neural prosthetic and neural interface applications," *Adv. Mater.*, vol. 27, no. 46, pp. 7620–7637, Dec. 2015.
- [102] D. Khodagholy *et al.*, "Neurogrid: Recording action potentials from the surface of the brain," *Nature Neurosci.*, vol. 18, no. 2, pp. 310–315, Feb. 2015.
- [103] C. L. Weaver, J. M. LaRosa, X. Luo, and X. T. Cui, "Electrically controlled drug delivery from graphene oxide nanocomposite films," *ACS Nano*, vol. 8, no. 2, pp. 1834–1843, Feb. 2014.
- [104] M. Lee, H. J. Shim, C. Choi, and D. H. Kim, "Soft high-resolution neural interfacing probes: Materials and design approaches," *Nano Lett.*, vol. 19, no. 5, pp. 2741–2749, May 2019.
- [105] R. Terry, "Vagus nerve stimulation: A proven therapy for treatment of epilepsy strives to improve efficacy and expand applications," in *Proc. IEEE Conf. Eng. Med. Biol. Soc.*, 2009, vol. 2009, pp. 4631–4634.
- [106] W. M. Grill, S. E. Norman, and R. V. Bellamkonda, "Implanted neural interfaces: Biochallenges and engineered solutions," *Annu. Rev. Biomed. Eng.*, vol. 11, pp. 1–24, 2009.
- [107] K. Singh, F. J. Richmond, and G. E. Loeb, "Recruitment properties of intramuscular and nerve-trunk stimulating electrodes," *IEEE Trans. Rehabil. Eng.*, vol. 8, no. 3, pp. 276–285, Sep. 2000.
- [108] K. Deisseroth, "Optogenetics," *Nature Methods*, vol. 8, no. 1, pp. 26–29, Jan. 2011.
- [109] K. L. Montgomery, S. M. Iyer, A. J. Christensen, K. Deisseroth, and S. L. Delp, "Beyond the brain: Optogenetic control in the spinal cord and peripheral nervous system," *Sci. Translational Med.*, vol. 8, no. 337, May 2016, Art. no. 337rv5.
- [110] C. Towne, K. L. Montgomery, S. M. Iyer, K. Deisseroth, and S. L. Delp, "Optogenetic control of targeted peripheral axons in freely moving animals," *PLoS One*, vol. 8, no. 8, 2013, Art. no. e72691.
- [111] S. M. Iyer *et al.*, "Virally mediated optogenetic excitation and inhibition of pain in freely moving nontransgenic mice," *Nature Biotechnol.*, vol. 32, no. 3, pp. 274–278, Mar. 2014.
- [112] H. Liske *et al.*, "Optical inhibition of motor nerve and muscle activity in vivo," *Muscle Nerve*, vol. 47, no. 6, pp. 916–921, Jun. 2013.
- [113] F. B. Carr and V. Zachariou, "Nociception and pain: Lessons from optogenetics," *Frontiers Behav. Neurosci.*, vol. 8, no. 69, pp. 1–6, 2014.

- [114] N. Li *et al.*, "Optogenetic-guided cortical plasticity after nerve injury," *Proc. Nat. Acad. Sci.*, vol. 108, no. 21, pp. 8838–8843, May 2011.
- [115] S. M. Iyer *et al.*, "Optogenetic and chemogenetic strategies for sustained inhibition of pain," *Sci. Rep.*, vol. 6, Aug. 2016, Art. no. 30570.
- [116] T. Ativanichayaphong, J. W. He, C. E. Hagains, Y. B. Peng, and J. C. Chiao, "A combined wireless neural stimulating and recording system for study of pain processing," *J. Neurosci. Methods*, vol. 170, no. 1, pp. 25–34, May 2008.
- [117] J. Xu, H. Guo, A. T. Nguyen, H. Lim, and Z. Yang, "A bidirectional neuromodulation technology for nerve recording and stimulation," *Micromachines*, vol. 9, no. 11, p. 538, Oct. 2018.
- [118] D. W. Park *et al.*, "Graphene-based carbon-layered electrode array technology for neural imaging and optogenetic applications," *Nature Commun.*, vol. 5, Oct. 2014, Art. no. 5258.
- [119] X. Liu, Y. C. Lu, E. Iseri, Y. H. Shi, and D. Kuzum, "A compact closed-loop optogenetics system based on artifact-free transparent graphene electrodes," *Frontiers Neurosci.*, vol. 12, p. 132, Mar. 2018.
- [120] G. Gagnon-Turcotte, I. Keramidis, C. Ethier, Y. De Koninck, and A. B. Gosselin, "A wireless electro-optic headstage with a 0.13- μm CMOS custom integrated DWT neural signal decoder for closed-loop optogenetics," *IEEE Trans Biomed Circuits Syst.*, vol. 13, no. 5, pp. 1036–1051, Oct. 2019.
- [121] A. E. Mendrela *et al.*, "A high-resolution opto-electrophysiology system with a miniature integrated headstage," *IEEE Trans. Biomed. Circuits Syst.*, vol. 12, no. 5, pp. 1065–1075, Oct. 2018.
- [122] J. P. Newman, M. F. Fong, D. C. Millard, C. J. Whitmire, G. B. Stanley, and S. M. Potter, "Optogenetic feedback control of neural activity," *Elife*, vol. 4, Jul. 2015, Art. no. e07192.
- [123] T. K. Nguyen *et al.*, "Closed-loop optical neural stimulation based on a 32-channel low-noise recording system with online spike sorting," *J. Neural Eng.*, vol. 11, no. 4, Aug. 2014, Art. no. 046005.
- [124] C. Armstrong, E. Krook-Magnuson, M. Oijala, and I. Soltesz, "Closed-loop optogenetic intervention in mice," *Nature Protocols*, vol. 8, no. 8, pp. 1475–1493, Aug. 2013.
- [125] D. R. Sparta, A. M. Stamatakis, J. L. Phillips, N. Hovelso, R. van Zessen, and G. D. Stuber, "Construction of implantable optical fibers for long-term optogenetic manipulation of neural circuits," *Nature Protocols*, vol. 7, no. 1, pp. 12–23, Dec. 2011.
- [126] R. Scharf, T. Tsunematsu, N. McAlinden, M. D. Dawson, S. Sakata, and K. Mathieson, "Depth-specific optogenetic control in vivo with a scalable, high-density μLED neural probe," *Sci. Rep.*, vol. 6, 2016, Art. no. 28381.
- [127] M. Schwaerzle, O. Paul, and P. Ruther, "Compact silicon-based optrode with integrated laser diode chips, SU-8 waveguides and platinum electrodes for optogenetic applications," *J. Micromech. Microeng.*, vol. 27, no. 6, 2017, Art. no. 065004.
- [128] F. Wu, E. Stark, P.-C. Ku, K. D. Wise, G. Buzsáki, and E. Yoon, "Monolithically integrated μLEDs on silicon neural probes for high-resolution optogenetic studies in behaving animals," *Neuron*, vol. 88, no. 6, pp. 1136–1148, 2015.
- [129] A. Rashidi, K. Laursen, S. Hosseini, and F. Moradi, "An ultrasonically powered optogenetic microstimulators with power-efficient active rectifier and charge reuse capability," in *Proc. IEEE Int. Symp. Circuits and Syst.*, 2019, pp. 1–5.
- [130] J. Y. Sim, M. P. Haney, S. I. Park, J. G. McCall, and J. W. Jeong, "Microfluidic neural probes: In vivo tools for advancing neuroscience," *Lab Chip*, vol. 17, no. 8, pp. 1406–1435, Apr. 2017.
- [131] A. Canales *et al.*, "Multifunctional fibers for simultaneous optical, electrical and chemical interrogation of neural circuits in vivo," *Nature Biotechnol.*, vol. 33, no. 3, pp. 277–284, Mar. 2015.
- [132] H. Cao, L. Gu, S. Mohanty, and J.-C. Chiao, "An integrated μLED optrode for optogenetic stimulation and electrical recording," *IEEE Trans. Biomed. Eng.*, vol. 60, no. 1, pp. 225–229, Jan. 2013.
- [133] M. M. Ghanbari *et al.*, "A Sub-mm ultrasonic free-floating implant for multi-mote neural recording," 2019, arXiv:1905.09386.
- [134] K. L. Montgomery *et al.*, "Wirelessly powered, fully internal optogenetics for brain, spinal and peripheral circuits in mice," *Nature Methods*, vol. 12, no. 10, pp. 969–974, Oct. 2015.
- [135] K. O. Htet, J. W. Zhao, R. Ghannam, and H. Heidari, "Energy-efficient start-up power management for batteryless biomedical implant devices," in *Proc. 25th IEEE Int. Conf. Electron., Circuits Syst.*, 2018, pp. 597–600.
- [136] J. W. Zhao, R. Ghannam, M. Y. Yuan, H. Tam, M. Imran, and H. Heidari, "Design, test and optimization of inductive coupled coils for implantable biomedical devices," *J. Low Power Electron.*, vol. 15, no. 1, pp. 76–86, Mar. 2019.
- [137] G. Shin *et al.*, "Flexible near-field wireless optoelectronics as subdermal implants for broad applications in optogenetics," *Neuron*, vol. 93, no. 3, pp. 509–521. e3, 2017.
- [138] K. N. Noh *et al.*, "Miniaturized, battery-free optofluidic systems with potential for wireless pharmacology and optogenetics," *Small*, vol. 14, no. 4, 2018, Art. no. 1702479.
- [139] S. I. Park *et al.*, "Ultraminiaturized photovoltaic and radio frequency powered optoelectronic systems for wireless optogenetics," *J. Neural Eng.*, vol. 12, no. 5, pp. 056002–56002, Oct. 2015.
- [140] K. O. O. Htet, R. Ghannam, Q. H. Abbasi, and H. Heidari, "Power management using photovoltaic cells for implantable devices," *IEEE Access*, vol. 6, pp. 42156–42164, 2018.
- [141] J. Zhao, R. Ghannam, Q. Abbasi, M. Imran, and H. Heidari, "Simulation of photovoltaic cells in implantable application," in *Proc. IEEE SEN-SORS*, New Delhi, India, 2018, pp. 1–4.
- [142] J. Zhao, K. Oo Htet, R. Ghannam, M. Imran, and H. Heidari, "Modelling of implantable photovoltaic cell based on human skin types," in *Proc. 5th Conf. PhD Res. Microelectronics Electron. (PRIME 2019)*, Lausanne, Switzerland, 2019, pp. 253–256.
- [143] T. Tokuda *et al.*, "1 mm³-sized optical neural stimulator based on CMOS integrated photovoltaic power receiver," *AIP Adv.*, vol. 8, no. 4, 2018, Art. no. 045018.
- [144] D. Seo *et al.*, "Wireless recording in the peripheral nervous system with ultrasonic neural dust," *Neuron*, vol. 91, no. 3, pp. 529–539, Aug. 2016.
- [145] B. C. Johnson *et al.*, "StimDust: A 6.5 mm³, wireless ultrasonic peripheral nerve stimulator with 82% peak chip efficiency," in *Proc. IEEE Custom Integr. Circuits Conf.*, 2018, pp. 1–4.
- [146] J. Charthad *et al.*, "A mm-sized wireless implantable device for electrical stimulation of peripheral nerves," *IEEE Trans. Biomed. Circuits Syst.*, vol. 12, no. 2, pp. 257–270, Apr. 2018.
- [147] J. W. Jeong *et al.*, "Wireless optofluidic systems for programmable in vivo pharmacology and optogenetics," *Cell*, vol. 162, no. 3, pp. 662–674, Jul. 2015.
- [148] M. Zaeimbashi *et al.*, "NanoNeuroRFID: A wireless implantable device based on magnetoelectric antennas," *IEEE J. Electromagn., RF Microw. Med. Biol.*, vol. 3, no. 3, pp. 206–215, Sep. 2019.
- [149] N. Ahmadi *et al.*, "Towards a distributed, chronically-implantable neural interface," in *Proc. 9th Int. IEEE/EMBS Conf. Neural Eng.*, 2019, pp. 719–724.
- [150] H. S. Gougheri, Y. Jia, J. Chen, I.-C. Khoo, N. Giebink, and M. Kiani, "Towards Wireless Addressable Optoelectronic Implants for Large-Scale Optogenetics," in *Proc. IEEE Int. Symp. Circuits Syst.*, 2019, pp. 1–4.
- [151] L. Lu *et al.*, "Wireless optoelectronic photometers for monitoring neuronal dynamics in the deep brain," *Proc. Nat. Acad. Sci.*, vol. 115, no. 7, pp. E1374–E1383, Feb. 2018.
- [152] G. Gagnon-Turcotte, M. N. Khirak, C. Ethier, Y. De Koninck, and B. Gosselin, "A 0.13- μm CMOS SoC for simultaneous multichannel optogenetics and neural recording," *IEEE J. Solid-St Circuits*, vol. 53, no. 11, pp. 3087–3100, Nov. 2018.
- [153] A. D. Mickle *et al.*, "A wireless closed-loop system for optogenetic peripheral neuromodulation," *Nature*, vol. 565, no. 7739, pp. 361–365, Jan. 2019.



Rupam Das (Member, IEEE) received the B.Sc. degree in electrical and electronics engineering from the Chittagong University of Engineering and Technology, Chittagong, Bangladesh, in 2011, and the M.Sc. and Ph.D. degrees in biomedical engineering from the University of Ulsan, Ulsan, South Korea, in 2013 and 2017, respectively. From 2017 to 2019, he was a Brain Korea 21 Plus (BK21 Plus) Postdoctoral Fellow with the Hanyang University, Seoul, South Korea. He is currently a Research Associate with the Microelectronics Laboratory, School of Engineering, University of Glasgow, Glasgow, U.K. His current research interests include implantable brain devices, microelectronics, wireless power transfer, metamaterial, and magnetic resonance imaging safety.



Farshad Moradi (Senior Member, IEEE) received the B.Sc. and M.Sc. degrees in electrical engineering from the Isfahan University of Technology, Isfahan, Iran and Ferdowsi University of Mashhad, Mashhad, Iran, respectively. He received the Ph.D. degree in nanoelectronics from the University of Oslo, Oslo, Norway, in 2011. From 2009 to 2010, he visited the Nanoelectronic Research Laboratory with Purdue University, USA. He started his academic career as an Assistant Professor with the School of Engineering, Aarhus University in 2011, and he is currently an

Associate Professor with the Department of Engineering, Aarhus University, Aarhus, Denmark. He is the Director of the Integrated Circuit and Electronics Laboratory leading Integrated Nanoelectronics Group. He is the Author Coauthor of more than 100 journal and conference papers. His current research interests include ultra-low-power mixed-signal IC design from device to architecture with more focus towards biomedical applications.



Hadi Heidari (Senior Member, IEEE) received the Ph.D. degree in microelectronics from the University of Pavia, Pavia, in 2015. He is an Assistant Professor (Lecturer) with the James Watt School of Engineering and lead of the Microelectronics Lab (meLAB), University of Glasgow, Glasgow, U.K. He worked on Integrated CMOS Sensory Microsystems. He has Authored more than 140 articles in peer reviewed journals (e.g., IEEE Solid-State Circuits Journal, Transactions Circuits and Systems I and IEEE Transactions Electron Devices) and in international conferences.

He has organized several conferences, workshops and special sessions, e.g., he is founder chairs of UK-China Emerging Technology workshop, UK Circuits and Systems workshop, and member of organizing committee of SENSORS' 17-'18, BioCAS' 18 and PRIME'2019. He is an Editor for the Elsevier Microelectronics Journal and lead Guest Editor for four journal special issues. He is member of the IEEE Circuits and Systems Society Board of Governors (BoG), and Member-at-Large IEEE Sensors Council. He has received several best paper awards from IEEE international conferences including ISCAS' 14, PRIME' 14, ISSCC' 16, and travel scholarship from IEEE NGCAS' 17. He has grant portfolio of +£1 million funded by major research councils and funding organizations including European Commission, UK's EPSRC, Royal Society and Scottish Funding Council.