

## BIOMASS GASIFICATION WITH CHP PRODUCTION – A REVIEW OF STATE OF THE ART TECHNOLOGY AND NEAR FUTURE PERSPECTIVES

by

**Goran G. JANKES\***, **Marta R. TRNINIĆ**, **Mirjana S. STAMENIĆ**, **Tomislav S. SIMONOVIĆ**, **Nikola D. TANASIĆ**, **Jerko M. LABUS**

Faculty of Mechanical Engineering, Department for Process Engineering, University of Belgrade, 11000 Belgrade, Serbia

Original scientific paper

UDC:

DOI:

*This paper is a review of the state of the art of biomass gasification and the future of using biomass in Serbia and it presents researches within the project "The Development of a CHP Plant with Biomass Gasification".*

*The concept of downdraft demonstration unit coupled with gas engine is adopted. Downdraft fixed-bed gasification is generally favored for CHP, owing to the simple and reliable gasifiers and low content of tar and dust in produced gas. The composition and quantity of gas and the amount of air are defined by modeling biomass residues gasification process. The gas (290-400m<sup>3</sup>/h for 0.5–0.7MW biomass input) obtained by gasification at 800°C with air at atmospheric pressure contains 14% H<sub>2</sub>, 27% CO, 9% CO<sub>2</sub>, 2% CH<sub>4</sub>, and 48% N<sub>2</sub>, and its net heating value is 4.8-6 MJ/Nm<sup>3</sup>. The expected gasifier efficiency is up to 80%. The review of the work on biomass gasification has shown that the development of technology has reached the mature stage. There are CHP plants with biomass gasification operating as demonstration plants and several gasification demonstration units are successfully oriented to biofuel production. No attempt has been made here to address the economic feasibility of the system. Economics will be the part of a later work as firmer data are acquired.*

*Key words: energy intensity, energy efficiency, energy consumption*

### 1. Introduction

Generally, biomass is considered to be an important potential fuel and renewable energy source in the future.

In the EU countries, the use of biomass for power generation has increased over the recent years mainly due to the implementation of a favorable European and national political framework. In the EU-25, electricity generation from biomass (solid biomass, biogas and biodegradable fraction of municipal solid waste) grew by 19% in 2004 and 23% in 2005, [1]. Depending on the growth of the power sector in EU countries, renewable energy sources (RES) will contribute between 33% and 40% to total electricity production and with 25% in total heat production in 2020 [1].

Considering environmental protection issues, biomass is favorable fuel due to the closed

---

\* Corresponding author; e-mail: [gjankes@mas.bg.ac.rs](mailto:gjankes@mas.bg.ac.rs)

circle of carbon-dioxide (carbon-dioxide, produced in combustion processes, is used for oxygen production in photosynthesis) [2].

Political, economic and environmental drivers in Serbia have pushed energy to the forefront of international politics in recent years. The Republic of Serbia has initiated an ambitious program aiming at the reform and stabilization of all sectors also including the energy sector. Within this framework, in 2004, the country adopted the Energy Law, while in 2005, Serbian Parliament adopted, the Strategy of the Long-Term Energy Development of the Republic of Serbia by 2015 outlining the country's major energy challenges over the next years and possible ways of meeting them. In 2007, Serbia ratified the Kyoto Protocol taking over the responsibility to increase the amount of energy produced from RES. The natural potential of Serbia is undoubtedly large, with estimation of up to 20% until 2012 [3]. Moreover, in line with the Energy Law and the Strategy, the Ministry of Mining and Energy has prepared the Energy Strategy Implementation Program - ESIP 2007–2012, which defines conditions, methods and time schedule for the implementation of the Strategy in all major parts of the energy sector [4]. The international obligation of the Republic of Serbia according to the EU Directive 2009/28/EC is to introduce 20% of RES energy and 10% of RES energy in the final consumption of transport. In November 2009, as one of the first steps to implement the above mentioned Directive, the Republic of Serbia introduced feed-in tariffs for the production of electricity from renewable energy sources with two main documents: The Decree on Conditions for Acquiring the Status of Privileged Producers and the Criteria for Granting the Status and The Decree on Feed-In Tariffs for RES Energy Generation. In spite of that, the production of energy from renewable sources is just a significant potential for Serbia at this moment.

At present, the Serbian energy scene is dominated by concerns for the security of energy supply, development and poverty mitigation. The major energy demand is provided from fossil fuels. Currently, the Republic of Serbia is not able to settle energy needs with available domestic primary energy sources and therefore 30-40% of annual energy needs are imported. According to data in the Energy Balance for 2011, the Republic of Serbia has high dependence on imports (5.31 Mtoe in 2010) of primary energy sources (oil and natural gas) [5]. On the other hand, the total renewable energy potential in Serbia is more than 4.3 Mtoe per year [6]. The most important source of biomass in Serbia is in agriculture and forestry (2.7 Mtoe) [6].

It is easy to conclude that renewable energy sources can have a strategic role in keeping the balance between energy supply and demand in Serbia. Unfortunately, the production of energy from renewable sources in Serbia is still present only in some small project attempts and pilot facilities.

Biomass is not currently used for electricity generation. However, new facilities are installed in food and processing industry. Belgrade Municipal Heating Company is developing a new plant in Krnjaca with two boilers each of 5 MW installed power on biomass (soy and wheat straw). There have also been some initiatives to develop biomass-fuelled district heating project in Eastern Serbia (Negotin) but the feasibility study concluded that the project was not economically justifiable [7].

The main reasons for inefficient use of RES are the following: the lack of appropriate technologies for the use of biomass as fuel at the market, low energy prices and the lack of the support for R&D are the reasons for no commercial application and interest.

There is a wide range of thermal processes under development from experimental to demonstration stages for secondary fuels (gas, liquid), or heat production [2]. Priority in Europe is given to gasification combined with heat and electricity production. Two concepts are in consideration: centralized district combined power plants, or small scale gasifiers coupled with boiler or diesel engines for local use of heat and/or electricity [2]. According to the present situation in Serbia (investment limitations, ways of collecting, storage and transportations of biomass), the

good estimations of the research team of the Department of Process Engineering are that the small-scale local usage is more realistic for near future than large centralized combined heat and power plants.

The paper presents researches within the project "The Development of a CHP Plant with Biomass Gasification" TR 33049, supported by the Ministry of Education and Science of the Republic of Serbia. This Project presents one of possible methods for using corncobs in the process of biomass gasification and combined heat and power generation.

As a result of the project "The Development of a CHP Plant with Biomass Gasification", the fixed bed downdraft gasifier of 0.5 – 0.6 MW is developed. Within this project, modeling of the gasification process with maize residues (corncobs) as fuel and modeling of coupling of gasification process to gas engines are realized. Downdraft gasification is generally favored for heat and electricity generation because of the low content of tar and dust in syngas.

## 2. Potential of Biomass Sources

With the territory of 88,361 km<sup>2</sup> and 7.4 million inhabitants (including the territory of Kosovo and Metohia) Serbia belongs to the group of middle size European countries. Generally, the northern part of the territory of Serbia is plain agricultural area, while the southern part is a mountainous region rich in forests. Agriculture is the basic occupation of the large part of Serbian population. Somewhat below half of the total population (44%) lives in rural areas, and most of them are engaged in agriculture and associated activities. Agriculture represents a very important factor in the country's economy, (14.842 % of GDP in 2011, [8]), as well as foreign trade (trade of agricultural products accounts for 12.8% of the country's total foreign trade).

Technically useful energy potential of the biomass energy sources in the Republic of Serbia is very significant and estimated at over 31.4 TWh per annum - of which 19.8 TWh lies in unused agricultural waste and residues from farming.

Agricultural residues are the main biomass renewable sources. Agriculture land in Serbia is occupying the area of 5,100,000 ha out of which, 3,600,000 ha is cultivated [10]. The main area for crops production is the northern part of the country (Fig.1), with production of maize, soy, barley, rye, wheat and other.

The most widely planted agricultural crops in Serbia are maize, wheat, sunflower and soybean [9]. The main area of fruit growing, another source of biomass waste, is the southern hilly region, mainly producing plums, apples, cherries, peaches, and grapes [9].

A great deal of crop farming production, almost 75%, is achieved in small or medium size private companies, while only about 25% of crop farming production belongs to agricultural companies of relatively larger size [2]. These two groups of agricultural producers have different practice of using biomass residues. Presently, in large agricultural farms much less biomass residues are used for livestock breeding than at small private farms [10]. But, at small agricultural farms, from their point of view it is useless to collect biomass residues after harvesting. The reasons are: no need for using biomass residues for cattle breeding, their existing domestic stoves or boilers are not adjusted to burning large pieces of straw or similar raw (unprocessed) biomass residues, and there is no market for selling biomass residues [10]. As a result, they often burn down straw and other biomass residues at fields. In addition, it is not easy for another entity to organize and achieve low cost collecting of biomass residues from many small and scattered fields [10]. The total biomass residues from fruit growing can be estimated at about 475,000 t and with its average heating value of 14 MJ/kg, the energy potential of biomass residues from fruit trees pruning is about 159,000 toe [10]. The energy potential of vine pruning residues alone is about 1.80265 TWh [10]. Kernels of plums, cherries, peaches, and apricots together with peels and seeds of apples, pears, and grapes are

waste derived from fruit processing. The quantity of this waste amounts to about 200,000 t [10]. With a relatively modest heating value of 9 GJ/t, the energy potential of fruit processing waste is about 0.53498 TWh [10].

This value is relatively small comparing to the energy potential of other fruit residues derived from growing. But an important advantage of this waste is that it is already collected in every company dealing with fruit processing. Therefore, this energy potential can be a remarkable source of energy in these fruit processing companies. A disadvantage of this kind of waste is its relatively high water content [10]. That is why for some waste, such as grape peels and seeds, a drying process will be necessary before it is used for energy conversion [10].

Biomass residues from different agricultural crops and fruits, which may be usable for energy production, are presented in Tables 1 and 2.

**Table 1. Agricultural Residues Available for Energy Use [9]**

Agricultural Cultures	Residues for Energy Use [1000t]
Wheat	1365
Barley	180
Rye	4.4
Corn	1140
Sunflower	240
Soybean	130
Rapeseed	1.6
<b>TOTAL</b>	<b>3060</b>

**Table 2. Fruit Residues Available for Energy Use [9]**

Fruit Cultures	Residues for Energy Use [1000t]
Plum	393.5
Apple	36.2
Cherries	55
Pear	14
Peach	35.1
Apricot	15.5
Walnuts	55
Grapes	515
<b>TOTAL</b>	<b>1119.3</b>

In addition to agricultural area, Serbia belongs to countries relatively rich in forests. The area of 1.98 Mha is covered with forests which account for around 25.6% of the total area of the Republic of Serbia. The forest area lies mainly on the south of Serbia but also at the east and west from the central part of Serbia (Fig.2).

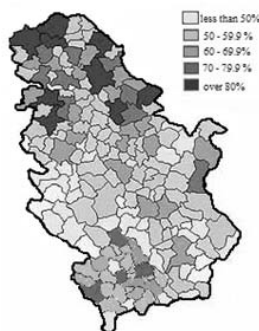

**Figure 1. The Geographic Distribution of Biomass Energy Potential**

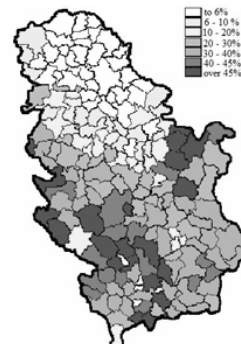

**Figure 2. The Geographic Distribution of Forest Energy Potential [9]**

About two thirds of forests are the property of state owned public companies; the rest is privately owned [10]. The main species of forest trees are: broadleaves, beech, poplar and oak, and conifers, which include black pine and spruce [10].

According to the statistical data about 1.2 million m<sup>3</sup> or about 50% of forest production

represents fuel wood [10]. The remaining assortments are wood pulp for pulp and paper industry, saw logs for cutting and wood for different technical purposes. Annual energy value of fuel wood presently used is 4.46 TWh. Residues of wood processing in saw mills resulting from the production of veneer, boards, and furniture, and residues in pulp and paper and chemical industry consist of small and large pieces: shavings, chips, cutting edge and bark [11].

Estimated annual yield of these wood residues is about 0.35-million m<sup>3</sup> with the energy value of 0.77 TWh. In a well-organized company, practically all quantity of wood waste is used in either board production or as fuel for heat and power production. However, some wood processing companies in Serbia have available wood biomass but they are not making a good use of it. Instead, they either spread the waste around their property, or simply dispose it into closest rivers, discarding a potentially valuable energy producing resource [11].

### 3. Corn cob as a Potential Fuel

The most widely planted agricultural crop in Serbia is corn. It is estimated, that almost 60% of agricultural field are planted with corn (area of approximately 2,160,000 ha). Corn residues, as stalks and leaves represented 47% and cobs represented 16% of the aboveground biomass. It is estimate that from 100 ha of agricultural areas planted with corn is possible to obtain about 130 t of corncob (which is equivalent to 10.8 TWh). This means that approximately 2.81 million tons per year of corncob are produced in Serbia. Only a small part of it is used for heat production, mainly in traditional stoves in villages.

Corn cobs have sufficient volumetric energy density and therefore they are suitable as an energy feedstock [12]. The higher the energy density, the less volume of biomass needed to produce a given amount of energy. While corn cobs are not as energy dense as fossil fuels, they have similar energy density to other biomass feedstock and less energy density than coals, both of which are successfully utilized as energy feedstock around the world [12]. For comparison, the volumetric and mass energy densities of several types of feedstock are given here on dry basis (Table 3).

The proximate and ultimate analysis is shown in the Table 4.

**Table 3. The Volumetric and Mass Energy Densities of Several Types of Feedstock\***

Fuel/Energy Content	Corn cobs	Corn Stover	Switch Grass	Wood Pellets	Bituminous Coal	Fuel Oil
[MJ/kg]	18.25-19.18	17	18	19	25.5	43.5
[MJ/m <sup>3</sup> ]	4,960-5,210	2,550	2,500	12,400	17,200-23,300	38,600

\* Sources: Clark, T.T. and Lathrop, E.C.; Foley, K.M.; Powder and Bulk; McLaughlin, S.B., *et al.*; EIA-DOE

**Table 4. Proximate Analysis and Ultimate Analysis of Corn cob**

Proximate Analysis [wt%, db]		Ultimate Analysis [wt%, db]	
VM	81.1	C	47.5
Fix-C	17.4	H	6.3
Ash	1.4	O	43.9
Low Heating Value, LHV [MJ/kg]	13.8	N	0.5
		S	0.1

As already mentioned, corn cobs are dense, structurally uniform, and they have high heat value, and low nitrogen and sulfur contents. As a direct heat source, corn cobs have low heat value of about 13.8 MJ/kg. The chemical properties and physical characteristics of corn cobs make them a feedstock suitable for several methods of energy generation.

#### 4. Biomass Gasification – An Overview

In order to benefit from chemical energy contained in biomass this energy has to be transformed into more convenient energy forms like heat or electricity. Gasification is a thermochemical conversion of solid carbonaceous feedstock (biomass, coal, or waste) into gaseous fuel (syngas), which contains carbon monoxide, hydrogen, carbon dioxide, methane, traces of higher hydrocarbons, water, nitrogen (if air is used as gasifying agent) and various amounts of tar and solid particles (ash, char) [2]. Syngas can be easily used for combined heat and power generation. Air gasification gives poor quality gas ( $\text{HHV} < 7 \text{ MJ/m}^3$ ), which is used locally in boilers, gas turbines, or IC engines. Oxygen gasification produces better quality gas ( $10\text{--}18 \text{ MJ/m}^3$ ), but because of high oxygen costs, it is preferred only in case of desulphurization of syngas prior to combustion in coal gasification processes [2]. Gasification with air is a widely used technology for waste and biomass conversion [13]. Gasification occurs at temperatures from  $700^\circ$  to  $1200^\circ \text{ C}$  when de-volatilized char chemically reacts with oxygen and/or hydrogen introduced by gasifying agent (air, oxygen, steam, hydrogen, carbon dioxide or mixture of some of these gases).

Gasification of biomass is generally observed to follow the reaction [14]:



Assuming a gasification process using biomass as a feedstock, the first step of the process is a thermochemical decomposition of the cellulose, hemicelluloses and lignin compounds with production of char and volatiles [15]. Further, the gasification of char and some other equilibrium reactions occurs.

Char gasification is a rate-limiting step in the production of gaseous fuels from biomass. The overall reaction rate is fairly constant throughout and declines only when the char is nearly depleted [14]. This suggests that the reaction rate depends on such factors as total available active surface area or interfacial area between char and catalyst particles [14]. These parameters remain relatively constant during the gasification process. Softwood and hardwood chars exhibited similar gasification behavior. Results indicate that mineral (ash) content and composition of original biomass material, and pyrolysis conditions under which char is formed significantly influence the char gasification reactivity [14].

One of the major problems in biomass gasification is how to deal with tar formed during the process. Tar is a complex mixture of condensable hydrocarbons which includes single ring to 5-ring aromatic compounds along with other oxygen containing hydrocarbons and complex polycyclic aromatic hydrocarbons (PAHs) [16]. Tar is undesirable because of various problems associated with condensation, formation of tar aerosols and polymerization to form more complex structures which cause problems in process equipment, as well as in engines and turbines using the produced gas [14]. However, minimum allowable limit for tar is highly dependent on the process type and end use application [14]. The preferable tar and dust loads in gases for engines must be lower than  $10 \text{ mg/m}^3$  [17].

According to literature ([18], [19]), tar and particle maximum concentrations in syngas for the use in gas engine are  $< 100 \text{ mg/m}^3$  and  $< 50 \text{ mg/m}^3$ , respectively.

Control technologies of tar production can broadly be divided into two approaches [20]: treatments inside the gasifier (primary methods) and hot gas cleaning after the gasifier (secondary methods). Although secondary methods are proven to be effective, treatments inside the gasifier are gaining much attention due to economic benefits. In primary methods, operating parameters, such as temperature, gasifying agent, equivalence ratio, residence time and catalytic additives, play important roles in the formation and decomposition of tar. Primary methods are not yet fully understood and have not to been implemented commercially [20].

Two types of gasifiers are commonly used for small-scale gasification: fixed bed gasifiers

and fluidized bed gasifiers.

In fixed bed reactors, there is fuel bulk filling (bed) in the reaction chamber. Fresh biomass is fed from the top of the reactor, introduced through an opening or sluice on the reactor head and sunk slowly downwards by gravity as conversion of fuel proceeds [22].

Depending on a relative direction of a gas stream and fuel bed movement, fixed bed reactors can be classified as: updraft or downdraft.

Downdraft fixed bed gasification is generally favored for small-scale heat and/or electricity generation owing to simple and reliable construction of gasifiers and to the low content of tar and dust in produced syngas. It is limited to relatively dry fuels (up to 30% wt. of moisture) in shape of blocks, chips, or pellets. As the ash fusion and clinker formation on grate is possible, fuels with non-slagging ash are preferred. Even with special design, its maximum size is probably limited to about 1 MWe. The experience in many development programs has shown that the classical downdraft gasifier cannot be scaled. The latest trend in downdraft gasification research is the development of small-scale, fully automatic units, dedicated to single well-defined fuel [2].

In updraft gasifiers, gasification medium and produced syngas flow through the gasification reactor in the opposite direction to the fuel bed. Thus, if the reactor is fed from above, the gasification media (air, oxygen, steam) enters the reactor in the area of the grate. The sensitive heat of the produced raw gas is used to dry the fuel and to start pyrolysis. As the output from the updraft gasifier, the raw gas is cooled on its way through the bulk filling, and the tar content in the raw gas can reach values over  $100 \text{ g/m}^3$  during gasification of the biomass [12].

Biomass gasification is the latest generation of biomass energy conversion processes, and it is used to improve efficiency and to reduce investment costs in bio-electricity generation through the use gas turbine technology or IC gas engines. Biomass gasifier gas turbines are projected to have bio-electricity efficiencies of 40–45%, or more than double those of Rankine-cycle systems. The gasification of biomass in fixed bed reactors provides the possibility of combined heat and power production in the power range of 100 kWe up to 5 MWe. A system for power production by means of fixed bed gasification of biomass consists of the main unit gasifier, gas cleaning system and gas turbine or IC gas engine [14].

The experience has shown that modified gas IC engines can run without problems on syngas with net heat value of 5-6 MJ/m<sup>3</sup>.

The capital cost of power plants with biomass gasification in the United States is about \$2000–\$3000/kW and generation cost is in the order of \$90/MWh. Such plants may be cost effective in CHP mode if connected to district heating schemes. The cost of biomass combustion steam cycle and CHP plants can be lower with \$1000/kW as the cost target. In Europe, the investment cost of biomass plants varies considerably from \$1000 to \$5000/kW depending on plant technology, level of maturity and plant size [14].

In order to get quality gas after gasification which can be used in gas engines for CHP production, the present paper discusses the strategies for tar removal. The reactor design is very crucial for gasification in terms of efficiency, heating value of product gas and also for tar formation. Downdraft gasification coupled with tar removal combustion chamber is presented here. Application of downdraft gasifier significantly lowers the content of tars and dust in produced syngas (tar concentrations around  $1 \text{ g/Nm}^3$ , [21]). In addition, after gasification, syngas is introduced into combustion chamber, where gas should be kept at least for 3 seconds at temperature of 800°C for efficient tar decomposition. For that reason, the chamber is filled with porous structure of Al<sub>2</sub>O<sub>3</sub> pebbles which slows down the gas and significantly reduces the chamber dimensions.

It should be mentioned that downdraft fixed bed gasification is generally favored for small-scale heat and/or electricity generation. It is limited to relatively dry fuels (up to 30% wt of moisture) in shape of blocks, chips, or pellets. As the ash fusion and clinker formation on grate is possible, fuels with non-slagging ash are preferred [2]. The limitations of diameter and particle size mean that

there is a practical upper limit to the capacity of standard configuration of 500 kg/h or 500 kWe [13]. Even with special design, its maximum size is probably limited to about 1 MWe. The experience in many development programs has shown that the classical downdraft gasifier cannot be scaled [2].

## 5. Overview of Activities Carried Out Within the Project TR33049

Biomass utilization in its various forms has gained reputation as one of the most promising methods to tackle the CO<sub>2</sub> issue which has risen and to slow down the rate of new fossil fuel units' construction. The first attempts to produce biodiesel started at the middle of 1990s during the sanctions and because of the lack of diesel fuels in Serbia. During this period, several chemical facilities were constructed or reconstructed to produce biodiesel. Although the plan was to produce 50,000 t of biodiesel, due to the undefined role of the state and the support system, this quantity was not achieved. In 2008, Serbia got a new factory for biodiesel production when the factory "Victoria Oil" in Sid, which fulfilled the requirements of the standard EN 14214, was constructed. In the same year, they started with the production of first quantities of biodiesel - around 25,000 t of biodiesel. The installed annual capacity of this factory is 100,000 t of biodiesel [10]. At this moment, it is hard to estimate at what time the factory will reach the full capacity since there is no stable market for biodiesel in Serbia. At the Department for Process Engineering of the Faculty of Mechanical Engineering, University of Belgrade, several experimental laboratory gasifiers have been designed and tested with different kinds of gasification processes using biomass and waste material. According to results of biomass and waste gasification experiments carried out several years ago at laboratory scale reactors at the Department for Process Engineering of the Faculty of Mechanical Engineering, University of Belgrade, but also according to results of many projects recently presented in literature, the concept of downdraft demonstration unit has been developed [2] and the downdraft gasification unit of thermal power 0.5 – 0.7 MW designed. Corncocks as widely available and also very suitable agricultural residue for gasification are chosen as biomass raw material. The principle of gasifier design is shown in Fig. 3 and the principal scheme of downdraft gasifier in demonstration plant for CHP is shown on Fig. 4.

Thermal power input of downdraft gasifier is 0.5 – 0.7 MW. Fuel feeding has to be carried out via gas-tight transfer inlet that prevents gas leakage and aspiration of excessive amounts of leakage air [22]. Corncocks are added from the top through a closed tube section. In the higher zone, some drying and heating (from radiation) is taking place. The air, needed for gasification process, is introduced lower down in order to produce heat for gasification [23]. The oxygen introduction is optionally possible. The air is supplied through nozzles into the combustion area at the temperature of approximately 350°C. The drying/pyrolysis zone lies above the oxidation zone and is supplied with the necessary process heat primarily through thermal conduction in bulk filling [23]. In the oxidation zone, primarily vaporous pyrolysis products react with the input gasification medium. The gases (CO<sub>2</sub> and H<sub>2</sub>O) from the oxidation zone are reduced to CO and H<sub>2</sub> by the char at the high temperature of the lower lying reduction zone [23]. Through these reactions, endothermic Boudouard and water gas reactions, the part of sensitive heat of gases is converted again into chemical energy of produced gas [23].



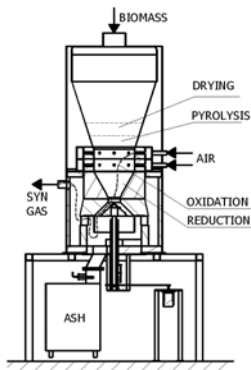

**Figure 3. Downdraft Gasifier Design**

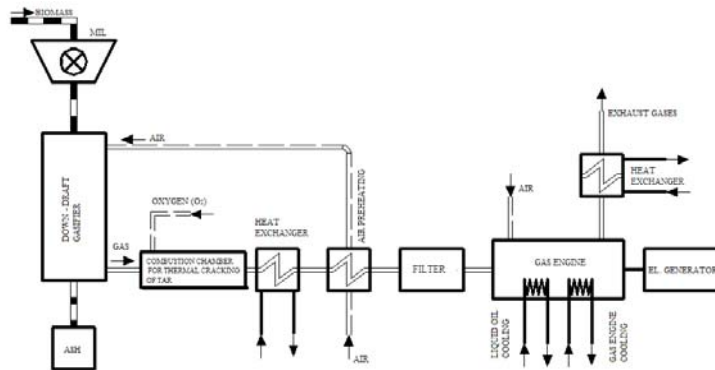

**Figure 4. Principle Scheme of Biomass Gasification Plant for CHP Production**

The gasification takes place in the conical part of the reactor and in a char layer over a rotating grid. If gas temperatures drop to a level at which no further reaction of the char with produced gas takes place [23], there will be a portion of unreacted char above ash grid that will be discharged with ash [23]. The speed of grid rotation determines the retention time of material in the reaction zone. Fine tuning of process parameters, especially temperature in the throat of the reactor and the speed of grid rotation, should keep the percentage of unreacted carbon in ash at low level. The ash is removed from the system using a cone grate system, also having the role of a stirrer for formed char. As the ash fusion and melted ash formation on grate is possible, operation parameters to prevent ash melting need to be studied carefully in demonstration experiments. The syngas is removed from the reactor close to the ash grid and it leaves the gasifier at approximately 700°C.

In the scope of the project “The Development of a CHP Plant with Biomass Gasification” it is suggested that gas clean-up problems can be largely avoided if biomass gasifier is coupled to the combustion chamber and tar cracking columns. As a small portion of oxygen will be introduced into the combustion chamber, a portion of gas will be combusted in order to reach gas temperature of 800°C. The combustion chamber is coupled with the regenerative heat exchanger – two columns filled with Al<sub>2</sub>O<sub>3</sub> pebbles where thermal decomposition of tar takes place. Tar free gas exits the combustion chamber at the temperature of approximately 700°C.

After tar cleaning, the syngas is carried through gas to water and gas to air heat exchangers for cooling. The purpose of gas cooling is to lower gas temperature which should meet the requirements of gas treatment equipment and provide optimal operation conditions. In this case, the gas is cooled down from 700°C to approx. 450°C in the gas to water heat exchanger. Hot water from the exchanger is used in the plant heating circuit. In the second heat exchanger (gas to air), ambient air used in gasification process is heated up to approx. 350°C while the syngas is cooled down to approx. 90°C, which is the temperature required for dry particle filtration in ceramic bag or fabric bag filters.

Cleaned gas is burned in a gas engine coupled with an electric generator. Based on the recommendations of the manufacturer (Jenbacher AG of Austria), the temperature range of below 90°C is required. Therefore, additional heat exchanger is introduced in front of the gas engine. In order to maintain stationary input parameters (to keep constant gas pressure for engines and also to avoid gas fluctuations during start up and shut down of engines), mixing of syngas with natural gas can be enabled. The expected electrical output is 130 - 180 kWel. The thermal energy from the

CHP plant (exhaust gas, internal cooling processes, *etc.*) can be used for energy supply of the nearby industrial site. In addition to the recovery of heat energy from engine exhaust gas, heat energy is available from engine block cooling; this, together with the recovered exhaust gas heat, as well as process heat from syngas cooling, can be fed into a heat distribution system of an industrial site (as it is proposed in the previous Project "Technologies for Using Biomass for Combined Heat and Power Generation", TR18026A).

## 6. Biomass Gasification Modeling

Corncocks have proven to be an ideal row material for gas production with the HHV of 18.6 MJ/kg (1.4% wt. ash).

The syngas composition, the amount of syngas and the amount of air are defined by modeling corncob gasification process.

The thermodynamic equilibrium model is used for downdraft gasifier in order to calculate the composition of syngas. The equilibrium models have been used by many researchers for the analysis of gasification process. Equilibrium models are valuable because they can predict thermodynamic limits as a guide to process design, evaluation and improvement. The advantage of equilibrium models is that they are independent of gasifier design and characteristics. Those models are based on the minimization of Gibbs free energy ([24], [25], [26]).

The main goal of these models is to enable studying a thermochemical processes during biomass gasification, evaluating the influence of main input variables, such as moisture content and air/fuel ratio, the syngas composition and its heating value.

For the model developed in this project, the following assumptions are made ([27], [28], [29], [30]):

1. Biomass is represented by general formula  $CH_xO_yN_zS_r$
2. Residence time of reactants is high enough to reach chemical equilibrium
3. Reactions are at thermodynamic equilibrium
4. Reactions proceed adiabatically
5. Reaction temperature and residence time for reactants are sufficiently high to reach chemical equilibrium
6. There is no tar in the gasification zone
7. Ash is inert and it is not involved in any reactions,
8. Gasification products contain  $CO_2$ ,  $CO$ ,  $H_2$ ,  $CH_4$ ,  $N_2$ , and  $H_2O$  (there is no oxygen in syngas - during the process of gasification only 20-40% of stoichiometric air is used).

With reference to all these assumptions, the most important one is that the residence time of reactants is high enough to reach chemical equilibrium. This hypothesis is confirmed by other authors [31], [32], [33]).

In the present model, the  $CH_xO_yN_zS_r$  formula is considered because it is suitable for different types of biomass utilization. Starting from ultimate analysis of biomass and mass fractions of carbon, hydrogen, oxygen, and nitrogen, substitution fuel formula  $CH_xO_yN_zS_r$ , based on single atom of carbon, can be calculated:

$$x = \frac{HM_C}{CM_H} \quad y = \frac{OM_C}{CM_{H_2O}} \quad z = \frac{NM_C}{CM_N} \quad r = \frac{SM_C}{CM_S} \quad (2)$$

where C, H, O, N, S and  $M_C$ ,  $M_H$ ,  $M_O$ ,  $M_N$ ,  $M_S$  are mass fractions and molecular weights of carbon, hydrogen, oxygen, nitrogen and sulphur, respectively. The algorithm that estimates the composition of syngas is based on chemical equilibrium between different species, and the global reaction can be written as [34]:

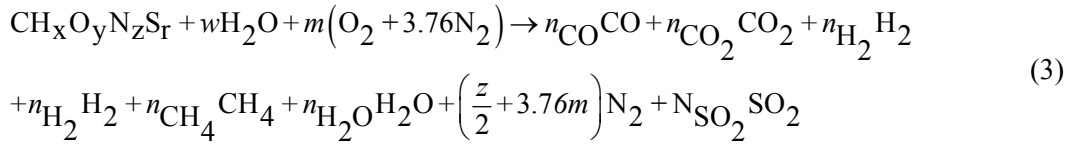

were  $w$  is the molar quantity of water per mole of biomass,  $m$  corresponds to the molar quantity of air used during the gasification process.

Model equations contain energy and mass balance (C, O, H and N) equations, equilibrium equations.

### 6.1. Model Equations

Considering the global gasification reaction, the first four equations are formulated by balancing each chemical element (**mass balance**):

$$\text{Carbon: } 1 - n_{\text{CO}} - n_{\text{CO}_2} - n_{\text{CH}_4} = 0 \quad (4)$$

$$\text{Oxygen: } y + 2m + w - n_{\text{CO}} - n_{\text{CO}_2} - n_{\text{H}_2\text{O}} - 2n_{\text{SO}_2} = 0 \quad (5)$$

$$\text{Hydrogen: } x + 2w - 2n_{\text{H}_2} - 4n_{\text{CH}_4} - 2n_{\text{H}_2\text{O}} = 0 \quad (6)$$

$$\text{Sulphur: } r - n_{\text{SO}_2} = 0 \quad (7)$$

The chemical equilibrium is usually explained either by minimization of Gibbs free energy or by using equilibrium constant. The temperature of gasification zone needs to be calculated in order to obtain equilibrium constants  $K_1$  and  $K_2$ . For this reason, energy balance is performed for the gasification process.

**Three equilibrium relations:**

$$1. \text{ Bouduard reaction: } K_1 = \frac{n_{\text{CO}}^2}{n_{\text{CO}_2}} \quad (8)$$

$$2. \text{ Water gas reaction: } K_2 = \frac{n_{\text{CO}}n_{\text{H}_2}}{n_{\text{H}_2\text{O}}} \quad (9)$$

$$3. \text{ Gas shift reaction: } K_3 = \frac{n_{\text{CO}}n_{\text{H}_2\text{O}}}{n_{\text{CO}_2}n_{\text{H}_2}} \quad (10)$$

$$\text{Equilibrium constants are given by: } \ln K = -\frac{\Delta G_T^0}{RT} \quad (11)$$

$$\Delta G_T^0 = \sum_i v_i \Delta g_{f,T,i}^0 \quad (12)$$

where  $\Delta G_T^0$  is standard Gibbs function of reaction,  $T$  is temperature in K and  $R$  is universal gas constant in consistent units.

$\Delta g_{f,T,i}^0$ , represents standard Gibbs function of formation at given temperature  $T$  of gas species  $i$  which can be expressed by empirical equation below, [35]:

$$\Delta g_{f,T,i}^0 = h_f^0 - a'T \ln(T) - b'T^2 - \left[ \frac{c'}{2} \right] T^3 - \left[ \frac{d'}{3} \right] T^4 + \left[ \frac{e'}{2T} \right] + f + g'T \quad (13)$$

The values of coefficients  $a$ – $g$  and the enthalpy of formation of gases are presented in Table 5.

**Table 5. The Value  $h_f^0$  [kJmol<sup>-1</sup>] and Coefficients of Empirical Equation for  $\Delta g_{f,T,i}^0$  [kJmol<sup>-1</sup>] [35]**

	$h$	$a \cdot 10^3$	$b \cdot 10^6$	$c \cdot 10^9$	$d \cdot 10^{12}$	$e'$	$f'$	$g'$
CO	110.5	5.619	-11.90	6.383	-1.846	-489.1	0.8684	-0.06131
CO <sub>2</sub>	-393.5	-19.49	31.22	-24.48	6.946	-489.1	5.27	-0.1207
H <sub>2</sub> O	-241.8	-8.950	-3.672	5.209	-1.478	0	2.868	-0.01722
CH <sub>4</sub>	-74.8	-46.20	11.30	13.19	-6.647	-489.1	14.11	-0.2234

The **energy balance** can be considered as follows [36]:

$$H_{prod}(T) = H_{react} + Q_{in} + Q_{out} \quad (14)$$

$$H_{react} = \sum_{react} n_i h_f^0 + \sum_{react} n_i \int_{298}^{T_i} C_{pi} dT \quad (15)$$

$$H_{prod}(T) = \sum_{prod} n_{ipg} h_f^0 + \sum_{prod} n_{pg} \int_{298}^{T_i} C_{pipgp} dT \quad (16)$$

where  $h_f^0$  is the enthalpy of formation (kJ/kmol) and its value is zero for all chemical elements at reference state (298 K, 1.013 bar) [36].

According to the first thermodynamic principle, the enthalpy of products at reaction temperature (T) is equal to the enthalpy of biomass, moisture and air incremented with heat inputs (preheating,  $Q_{in} > 0$ ) and heat outputs (heat loss,  $Q_{out} < 0$ ).

## 6.2. Valuation

To solve the values of  $n_{CO}$ ,  $n_{H_2}$ ,  $n_{CO_2}$ ,  $n_{H_2O}$ ,  $n_{CH_4}$ , initial temperature is assumed and substituted into Eqs. (10) and (12) to initially calculate  $K_1$  and  $K_2$ . Then, both equilibrium constants are substituted into Eqs. (8) and (9), respectively. Finally, all results are substituted into equations, Eqs. (4), (5), (6), (7). For calculating the new value of temperature, Eq. (13) is used. The outlined procedure is repeated until temperature value is converged. EES software is used for modeling gasification process. For biomass input of 140 - 190 kg/h, the amount of air needed for gasification is estimated to be 150 - 210 m<sup>3</sup>/h.

The composition of syngas after the process of gasification is presented in Table 6. The output of the gasifier is determined to be approximately 290 - 400 m<sup>3</sup>/h (dry raw gas at normal conditions), with lower heating value (LHV) of 5.5 MJ.

**Table 6. Gas Composition after Downdraft Gasification of Corncobs**

Gas Composition [vol%, db]	
CO	26.7
CO <sub>2</sub>	9.5
H <sub>2</sub>	13.5
CH <sub>4</sub>	2
N <sub>2</sub>	48.3
Low Heating Value, LHV [MJ/kg]	5.5

The material and energy balance of gasification plants shows that the efficiency of gasifier up to 80% can be expected.

Not a single biomass gasification system for commercial use has yet been built in the Republic of Serbia, but the process and system have been developed to the point that they can be safely offered to potential customers.

The presented concept of biomass gasification plant is in the construction phase in one industrial site near Belgrade. The plant is located in an agricultural region where corn is grown.

It is estimated that 1700t per year of corncobs are available for energy production. The available energy of this amount of corncobs is estimated at around 755toe (9 GWh). The utilization of corncobs will provide sufficient energy which can be used for electricity and heat generation.

The plant is designed to operate 7900 hours annually. At maximal load, the gasifier is fuelled with 190 kg of corncobs every hour and it is capable of gasifying 1500 tons of corncobs annually. The annual energy production is approximately 2.7 GWh of heat and 1.4 GWh of electricity.

The Sankey diagram with proportional energy flows of biomass gasification plant for CHP is presented in the fig. 5.

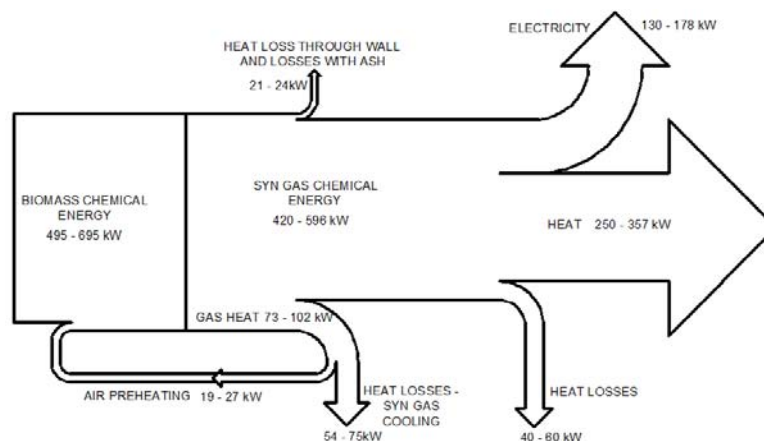

Figure 5. The Energy Flow in Biomass Gasification Plant with CHP, Sankey's Diagram

After implementation of biomass gasification CHP plant, gas cleaning and heat recuperation will be tested. Necessary testing will be done in order to determine the plant's pollutant emissions and, if necessary, to improve segments of equipment. The possible ways of developing future commercial plants will also be determined.

## 7. Conclusions

Renewable energy sources, especially biomass, play a key strategic role in maintaining the balance between energy supply and demand in Serbia. With its activities to join the EU, Serbia is adopting regulations of the EU, and national regulations will have to be harmonized with the Directive on the Promotion of the Use of Energy from Renewable Sources (2009/28/EC). Serbia is in the phase of determining its own national targets and making an activity plan for the fulfillment of designated targets. It is clear that significant attention will have to be devoted to this sector in the future. The success of biomass implementation in the energy sector of Serbia is limited by a combination of factors, such as inadequate planning policies, pricing distortions which have placed

renewable energy in a disadvantaged position, high initial capital costs and the lack of incentive funds. The total biomass energy potential in Serbia is approximately 2.7 million tons. Out of this amount, about 1.7 million tons refer to remains of agricultural production and about 1 million tons refer to wood biomass. It is estimated that almost 60% of agricultural fields are planted with corn (area of approximately 2,160,000 ha). This means that approximately 2.81 million tons per year of corncobs are produced in Serbia.

The small-scale gasification is a convenient and well-tested technology. The small-scale gasification plant is suitable for decentralized and independent energy generation in rural or isolated areas, companies with a need for heat and electricity energy with the use of cheap fuels (local biomass).

The paper presented the development of the downdraft gasifier with input thermal power 0.5-0.7 MW. Modeling of corncob gasification process shows that corncobs are a good quality fuel (LHV of 13.8 MJ/kg) which can be used to produce fairly high quality gas (LHV of 5.5 MJ/m<sup>3</sup>). The efficiency of gasifier up to 80% can be achieved.

After demonstration phase, it is expected that the plant will be commercialized and used for heat production or combined heat and electricity production in small-scale plants.

From this research, it is concluded that gasification of biomass residues is technically feasible and it is likely to have limited environmental impacts. However, more experimental data on biomass characteristics and gas engine tests will have to be collected. The sensitivity to fluctuations in syngas quality and mass flows, pre-treatment and feeding biomass materials should be investigated in practical experiments.

## Acknowledgments

It should be stated that the project TR33049 is funded by the Ministry of Education and Science of Serbia. The authors are also very grateful to the Norwegian University of Science and Technology, Trondheim, especially to professors Vojislav Novakovic and Morten Grønli, for a given opportunity to make experimental researches (biomass characterizations, biomass pyrolysis, *etc.*).

## Nomenclature

$C_p$	– specific heat capacity at constant pressure, $m$ [kJkg <sup>-1</sup> K <sup>-1</sup> ]	$n$	– molar quantity of air, [kmol/kmol] – numbers of mole
$C$	– mass fraction of carbon	$\dot{Q}$	– heat flow rate, [kJ/s]
$H$	– mass fraction of hydrogen	$T$	– temperature, [K]
HHV	– higher heating value, [kJ/kg]	$w$	– molar quantity of water per mole of biomass, [kmol/kmol]
LHV	– lower heating value, [kJ/kg]	$\Delta G_T^o$	– standard Gibbs function of reaction at temperature $T$
$O$	– mass fraction of oxygen	$\Delta g_{f,T,i}^o$	– standard Gibbs function of formation at temperature $T$
$N$	– mass fraction of nitrogen		
$S$	– mass fraction of sulphur		
$h_f^o$	– enthalpy of formation, [kJ/kmol]		
$M$	– molecular weight, [kg/kmol]		
$K$	– equilibrium constant		

## Greek Letters

$\nu$  – stoichiometric number

## Subscripts

prod – reaction products  
react – reaction reactants  
in – input to gasifying process  
out – output of gasifying process  
pg – produced gas

## References

- [1] Renewable Energy Technology Roadmap 20% by 2020, European Renewable Energy Council
- [2] Jankes, G., Milovanović, N., Biomass Gasification in Small-Scale Units for the Use in Agriculture and Forestry in Serbia, *Thermal Science*, 5 (2001), 2, pp. 49–57
- [3] Golusin M., Tesic Z., Ostojic A., The Analysis of Renewable Energy Production in Serbia, *Renewable and Sustainable Energy Reviews*, 14 (2010), pp. 1477–1483
- [4] Karakosta, C., Doukas, H., Flouri, M., Dimopoulou, S., Papadopoulou, A.G., Psarras, J., Review and Analysis of Renewable Energy Perspectives in Serbia, *International Journal of Energy and Environment*, 2 (2011), pp. 71-84
- [5] Energy Balances of the Republic of Serbia for 2011, Statistical Office of the Republic of Serbia and Ministry of Mining and Energy, Belgrade, 2010
- [6] Ministry of Energy and Mining, Renewable Energy Sources in Serbia, <http://www.mre.gov.rs/navigacija.php?IDSP=299>
- [7] Statistical Office of the Republic of Serbia. National Accounts of Serbia, Gross Domestic Product of the Republic of Serbia (1997-2007). Statistical Office of the Republic of Serbia, 2009
- [8] Information available at <http://www.economywatch.com/economic-statistics/country/Serbia/>
- [9] Ilic, M., Grubor, B., Tešić, M., The State of Biomass Energy in Serbia, *Thermal Science*, 8 (2004), pp. 5-19
- [10] Bogunovic A., Bogdanov N., Analysis of RES and its impact on Rural Development in Serbia, WP2: Studies, 2009
- [11] Feasibility Study on Wood Waste Utilization in Serbia, Energy Savings Group, available at [http://pdf.usaid.gov/pdf\\_docs/PNADS215.pdf](http://pdf.usaid.gov/pdf_docs/PNADS215.pdf)
- [12] Zyc, D., The Viability of Corncoobs as Bioenergy Feedstock, The literature review undertaken as part of summer internship in renewable energy at the West Central Research and Outreach Center, University of Minnesota, 2008
- [13] Bridgwater, A.V., The Technical and Economic Feasibility of Biomass Gasification for Power Generation, *Fuel*, 74 (1995), pp. 631–653
- [14] Balat, M., Balat, M., Kirtay, E., Balat, H., Main Routes for the Thermo-Conversion of Biomass into Fuels and Chemicals. Part 2: Gasification Systems, *Energy Conversion and Management*, 50 (2009), pp. 3158–3168
- [15] Balat, M., New Biofuel Production Technologies, *Energy Education Science & Technology*, 22 (2009), pp. 147–161
- [16] Devi, L., Ptasiniski, K.J., Janssen, F.J.J.G., A Review of Primary Measures for Tar Elimination in Biomass Gasification Processes, *Biomass and Bioenergy*, 24 (2003), pp. 125 – 140
- [17] Bui, T., Loof, R., Bhattacharya, S.C. Multi-Stage Reactor for Thermal Gasification of Wood, *Energy* 19 (1994), pp. 397–404
- [18] Rajvanshi, A. K., Biomass Gasification, in: *Alternative Energy in Agriculture*, Vol. II, (Ed. D. Yogi Goswami), CRC Press, 1986, pp. 83-102
- [19] Pathak, B.S., Kapatel, D.V., Bhoi, P.R., Sharma, A.M., Vyas, D.K., Design and Development of Sand Bed Filter for Upgrading Producer Gas to IC Engine Quality Fuel, *International Energy Journal*, 8 (2007), pp. 15-20
- [20] Knight, R.A., Experience with Raw Gas Analysis from Pressurized Gasification of Biomass, *Biomass and Bioenergy*, 18 (2000), pp. 67–77
- [21] Rabou, T. L. P. L. M., Zwart, R.W. R., Vreugdenhil, B. J., Bosar, L., Tar in Biomass Producer Gas, the Energy Research Centre of the Netherlands (ECN) Experience: An Enduring Challenge, *Energy Fuels*, 23 (2009), pp. 6189–6198
- [22] Lettner, F., Timmerer, H., Haselbacher, P., Biomass Gasification – State of the Art Description, in: *Guideline for Safe and Eco-Friendly Biomass Gasification*, Intelligent Energy – Europe (IEE), 2006, Ch. 8
- [23] Schaub, K., Gemperle, H., Pyroforce Power from Wood System Commercial Breakthrough Reached, *ThermalNET Newsletter*, 6 (2008), pp 12-14
- [24] Ruggiero, M., Manfrida, G. An Equilibrium Model for Biomass Gasification Process, *Renewable Energy*, 16 (1999), pp. 1106–1109

- [25] Tang, H, Kitagawa, K. Supercritical Water Gasification of Biomass: Thermodynamic Analysis with Direct Gibbs Free Energy Minimization, *Chemical Engineering Journal*, 106 (2005), pp. 261–267
- [26] Altafani, C.R., Wander, P.R., Barreto, R.M. Prediction of the Working Parameters of Wood Waste Gasifier through an Equilibrium Model, *Energy Conversion and Management*, 43 (2003), pp. 2763–77
- [27] Ramanan, M.V.; Lakshmanan, E.; Sethumadhavan, R.; Renganarayanan, S., Performance Prediction and Validation of Equilibrium Modeling for Gasification of Cashew Nut Shell Char, *Brazilian Journal of Chemical Engineering*, 25 (2008), pp. 585-601
- [28] Zainal, Z.A., Ali, R., Lean, C.H., Seetharamu, K.N., Prediction of Performance of a Downdraft Gasifier Using Equilibrium Modeling for Different Biomass Materials, *Energy Conversion and Management*, 42 (2001), pp. 1499-1515
- [29] Sharma, A.K., Equilibrium and Kinetic Modeling of Char Reduction Reactions in a Downdraft Biomass Gasifier: A Comparison, *Solar Energy*, 52 (2008), pp. 918-928
- [30] Khadse, A., Parulekar, P., Aghalayam, P., Ganesh, A., Equilibrium Model for Biomass Gasification, Department of Chemical Engineering, IIT Bombay, Powai, Mumbai, India and Energy Systems Engineering, IIT Bombay, Powai, Mumbai, India
- [31] Buekens, A. G. , Schoeters, J. G., Modeling of Biomass Gasification, in: *Fundamentals of Thermochemical Biomass Conversion*, (Eds. R. P. Overend, T. A. Milne, L. K. Mudge L. K.), Elsevier, pp. 619-689, 1985
- [32] Ruggiero, M., Manfrida, G., An Equilibrium Model for Biomass Gasification Processes, *Renewable Energy*, 16 (1999), pp. 1106-1109
- [33] Zainal, Z.A., Ali, R., Lean, C.H., Seetharamu, K.N., Prediction of Performance of a Downdraft Gasifier Using Equilibrium Modeling for Different Biomass Materials, *Energy Conversion and Management*, 42 (2001), pp. 1499-1515
- [34] Melgar, A., Pérez, J. F., Laget, H., Hornillo, A., Thermochemical Equilibrium Modeling of Gasifying Process, *Energy Conversion and Management*, 48 (2007), pp. 59-67
- [35] Jarungthammachote, S., Dutta, A., Thermodynamic Equilibrium Model and the Second Law Analysis of a Downdraft Waste Gasifier, *Energy*, 32 (2007), pp. 1660–1669
- [36] Melgar, A., Pérez, J. F., Laget, H., Hornillo, A. Thermochemical Equilibrium Modeling of Gasifying Process, *Energy Conversion and Management*, 48 (2007), pp. 59-67
- [37] Raveendran, K., Ganesh, A., Khilar, K., Influence of Mineral Matter on Biomass Pyrolysis Characteristic, *Fuel*, 74 (1995), pp. 1812–1822
- [38] Raveendran, K., Ganesh, A., Khilar, K., Pyrolysis Characteristic of Biomass and Biomass Components, *Fuel*, 75 (1996), pp. 987–998
- [39] Faaij, A., van Ree, R., Waldheim, L., Olsson, E., Oudhuis, A., van Wijk, A., Daey-Ouwens, C., Turkenburg, W., Gasification Of Biomass Wastes and Residues for Electricity Production, *Biomass and Bioenergy*, 12 (1997), pp. 387-407

Paper submitted: February 16, 2012

Paper revised: March 29, 2012

Paper accepted: April 2, 2012