



**Bipolar and Unipolar Tests of 1.5m Model
SSC Collider Dipole Magnets at Fermilab***

M. J. Lamm, J. P. Ozelis, K. J. Coulter, S. Delchamps,
T. S. Jaffery, W. Kinney, W. Koska, J. Strait, and M. Wake
*Fermi National Accelerator Laboratory
P.O. Box 500
Batavia, Illinois 60510*

D. Fortunato and D. E. Johnson
*SSC Laboratory
2550 Beckleymeade Avenue
Dallas, Texas 75237*

May 1991

* Presented at the *14th Biennial IEEE Particle Accelerator Conference*, May 6-9, 1991, San Francisco, CA.



BIPOLAR AND UNIPOLAR TESTS OF 1.5m MODEL SSC COLLIDER DIPOLE MAGNETS AT FERMILAB

M.J. Lamm, J.P. Ozelis, K. J. Coulter, S. Delchamps, T.S. Jaffery, W. Kinney, W. Koska, J. Strait, and M. Wake
Fermi National Accelerator Laboratory
P.O. Box 500, Batavia, Illinois 60510

D. Fortunato and D. E. Johnson
SSC Laboratory
2550 Beckleymeade Ave., Dallas, TX 75237

Abstract

Tests have been performed at Fermilab on 1.5m magnetic length model SSC collider dipoles using both bipolar and unipolar ramp cycles. Hysteresis energy loss due to superconductor and iron magnetization and eddy currents is measured and compared as a function of various ramp parameters. Additionally, magnetic field measurements have been performed for both unipolar and bipolar ramp cycles. Measurements such as these will be used to estimate the heat load during collider injection for the SSC High Energy Booster dipoles.

I. INTRODUCTION

An SSC model dipole has been tested for the first time using a bipolar ramp cycle. The purpose of these tests is to gain insight into the effects of bipolar operation as opposed to the more conventional unipolar operation, with regards to AC energy loss and magnet field harmonics reproducibility. It is expected that the AC energy losses from both superconductor hysteresis and eddy current heating will be larger in the bipolar case. It is also desired to determine the ramp rate dependence of these losses. These results and future tests on 50mm magnets will be used in design considerations of the bipolar SSC High Energy Booster[1].

II. EXPERIMENTAL DETAILS

A. Magnet Description

These tests were performed on a 40 mm aperture SSC model dipole built at Fermilab (DS0315). A complete description of the magnet design can be found elsewhere [2,3]. The inner (outer) coils are made of 30 (23) strand superconducting NbTi cable with a filament diameter of 6 microns and a Cu:SC ratio of 1.49, an RRR of 33, and a J_c of 1500A/mm² at 7 T. The twist pitch of the inner (outer) cable is 7.6 (7.4) cm. The 1.52mm thick collars are made of Nitronic 40 stainless steel locked in place with tapered stainless steel keys. The yoke consists of 1.52mm thick low carbon high quality magnetic steel laminations. A stainless steel shell surrounds the yoke and is seam welded longitudinally.

B. Test Facility

This magnet was tested in a 3.6 meter long vertical dewar located at the Superconducting Magnet R & D Facility at Fermilab. The dewar is instrumented with pressure transducers and liquid level gages. Carbon and platinum thermometers are mounted on the shell of the magnet to monitor the magnet temperature during cooldown and testing. By controlling the dewar vapor pressure,

the temperature of the boiling liquid helium bath can be varied between 3.2 and 4.35 K.

Current is supplied by a Transrex 500-5 unipolar power supply capable of supplying 7000 Amps at ramp rates in excess of 400 A/s. The bipolar current operation is achieved through an SCR based, water cooled current reversing switch that was designed for the Fermilab D0 low- β insertion [4].

Magnetic measurements are performed with a room temperature multiple winding Morgan coil. The coil is inserted into a anti-cryostat, which in turn is inserted into the bore of the magnet. The probe is rotated at 6 Hz, and the resultant voltages are processed through a V/F converter based data acquisition system.

The power supply, the bipolar switch, the magnetic measuring system and other magnet instrumentation are controlled and monitored with a μ VAX data acquisition computer through CAMAC and GPIB bus.

C. AC Loss Measurement System

The AC loss of a superconducting magnet can be determined by simultaneously measuring the voltage across the magnet and current through the magnet during a ramp cycle. Integration of the product $V \cdot I$ with respect to time over a closed current cycle yields the energy loss[5]. Previous methods required a "bucking" coil which subtracted the inductive component of the magnet voltage before the magnet voltage and current could be integrated[6,7,8]. For these measurements, we have instead digitally integrated the product $V \cdot I$ using high sensitivity digital integrating voltmeters, eliminating the need for a "bucking" coil, and substantially simplifying the measurement system.

The magnet voltage is sensed through voltage taps located at the immediate entrance to the magnet coils. The magnet voltage is measured using an HP Model 3457A digital voltmeter. The magnet current is determined using a 12 kA shunt, whose signal is likewise measured using an HP Model 3457A voltmeter. The data from the DVMS are transmitted through the GPIB bus to a PC.

The DVMS are synchronously triggered using a Wavetek Model 75 digital waveform generator, which provides a burst of square waves as trigger signals. The number of pulses in a burst is determined by the number of readings needed to capture a full ramp cycle. The DVMS integrate individual voltage readings for a period of 10 power-line cycles (0.167 secs.), and individual readings are stored in internal memory, to be read out in FIFO mode by the PC. Readings are taken at a frequency of 4.5 Hz, and 100 Hz low-pass input filters are used to eliminate high frequency voltage spikes resulting from the SCR firing pattern of the magnet power supply. Figure 1 indicates the measurement system and components.

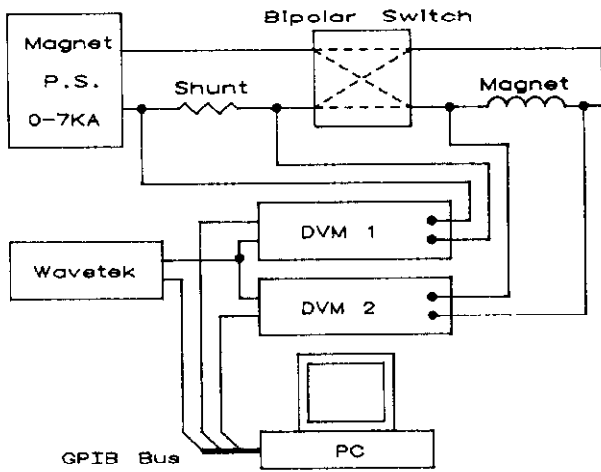

Figure 1. Schematic of the AC loss measurement system. The control elements for the power supply and bipolar switch are not shown.

The reproducibility of these measurements is typically about 5% at present, and can be enhanced by the application of a figure-of-merit criterion which requires that there be no discontinuities (resulting from noise in the magnet voltage signal) in the $V \cdot dt$ integral over a complete cycle. For measurement runs which satisfy this criterion, reproducibility is typically a few Joules. Signal-to-noise ratio of the magnet and shunt voltage signals can be optimized through careful shielding and isolation of the signal cables.

D. Unipolar AC Loss Studies

A measurement run typically consists of a set of 10 ramp cycles for each ramp rate to be studied. Data is not taken until after 3 cycles have elapsed, so that previously induced magnetization currents are erased. The first set of measurements performed were ramp rate studies of the AC loss for a unipolar ramp. A simple sawtooth-type ramp was used with 5 second dwells at I_{min} (50A or 500 A), and I_{max} (5000 A). These ramps were executed for a series of ramp rates, ranging from 30 A/sec to 300 A/sec.

E. Bipolar AC Loss Studies

A set of bipolar tests were performed using a sawtooth ramp with 5 second dwells at I_{min} (-5000 A), I_{max} (5000 A), and $I = 0$ A. The dwell at $I = 0$ is dictated by the operational characteristics of the bipolar switch, which requires that the current be maintained at 0 for about 5 seconds before reversing. Energy loss over a cycle was measured for ramp rates in the range 60 A/sec to 300 A/sec.

F. Bipolar Harmonics Measurements

The magnetic field can be described by the following :

$$B_y - iB_x = \sum_{n=0} (B_n - iA_n) * ((x+iy)/r_0)^n \quad (1)$$

where A_n and B_n are the skew and normal components and r_0 is the reference radius, chosen to be 1 cm. These coefficients are in units of Gauss, and are evaluated at the reference radius. The x and y directions are chosen so that the skew dipole term (A_0) is zero for non-zero transport current, and the normal dipole term (B_0) is positive for positive transport current.

Magnetic field measurements were performed using the unipolar and bipolar cycles described above in the AC loss studies, at a ramp rate of 100 A/sec. Data were recorded on the 4th and 5th cycle of each run set.

III. RESULTS

A. AC Loss Measurement Results

The results of the energy loss measurements for the unipolar ramp cycle from 500 to 5000 A are plotted in Figure 2 (lower plot). We conclude that the loss is essentially a linear function of the ramp rate. The intercept of the least-squares linear fit represents the loss due to hysteresis in the superconductor, and is about 60 Joules. The ramp rate dependence is found to be about 0.220 J/A/sec. This ramp rate dependence arises from losses due to eddy currents in the superconducting cable and the iron laminations of the magnet yoke, both of which increase with increasing ramp rate. These results are in good agreement with simple calculations performed for the expected energy loss of 40mm SSC dipoles[9].

The upper plot in Figure 2 represents the energy loss per cycle as a function of ramp rate for the second unipolar ramp type, where $I_{min} = 50$ A. Both the superconductor hysteresis and ramp rate dependence have increased as a result of the larger range in field strength for this cycle. The superconductor loss has now increased to 66 Joules, while the ramp rate dependence has increased to about 0.260 J/A/sec. The ramp rate dependence and superconductor loss are both expected to increase with the increase in field change, and our result agrees with this prediction[5].

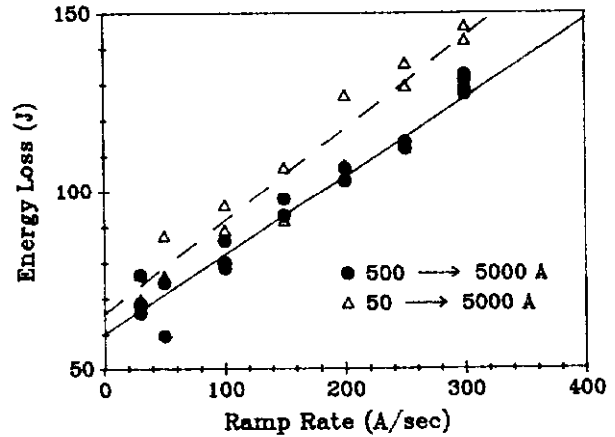

Figure 2. Energy loss per unipolar cycle as a function of ramp rate. Upper curve = 50 -> 5000 A cycle; lower curve = 500 -> 5000 A cycle.

The bipolar data, seen in Figure 3, show both larger superconductor hysteresis losses and eddy current losses, due to the field reversal that occurs during this ramp cycle. The superconductor hysteresis loss has changed from about 60 J to 188 J, an increase of about a factor of 3. The ramp rate dependence also has changed to 0.348 J/A/sec. These results are not surprising, as one would expect that bipolar hysteresis losses would be greater than their unipolar counterparts, as the area enclosed by a typical hysteresis curve (and, therefore, the energy loss associated with executing such a curve) in the bipolar case is generally greater than twice that of the unipolar case. This is due to the extra area of the curve where the magnetization is non-zero as the external field crosses the vertical axis when polarity is reversed.

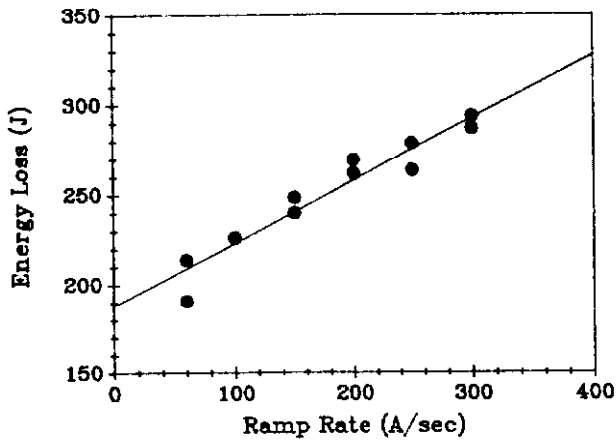

Figure 3. Energy loss per bipolar cycle as a function of ramp rate.

B. Harmonic Measurement Results

The same mechanism responsible for producing AC losses also causes hysteresis in the allowed magnetic multipoles. The largest effect can be observed in the normal sextupole (B_2) as shown below.

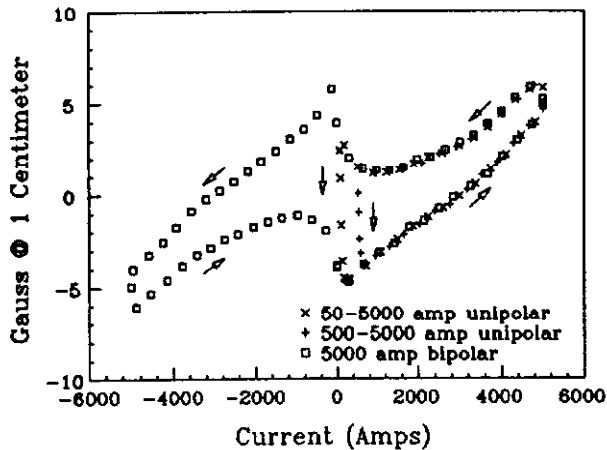

Figure 4. The normal sextupole (B_2) as a function of current for the unipolar and bipolar ramp cycles. Arrows indicate direction of B_2 and current change during the ramp cycles.

Data are shown for both unipolar ramp and the bipolar ramp cycles for the 4th cycle from the beginning of each set. The hysteresis curves for the 5th and subsequent cycles are identical, to within experimental error. The bipolar hysteresis curve appears to have inversion symmetry ($B_2(I) = -B_2(-I)$) as expected. The slope of the curve with increasing $|I|$ is due to the geometric contribution to the sextupole field. (The sextupole field has not been scaled by the value of the dipole, as is customarily done, since the dipole field also vanishes at $I=0$ A)

Except near I_{min} , which differs for the three sets of data, the unipolar curves lie on top of the positive portion of the bipolar curve. From I_{min} the unipolar ramps rejoin the unipolar hysteresis curve within 100 Amps of the up-ramp. Any observed deviation between unipolar and bipolar ramp cycles in the positive portion is attributable to measurement error, which is typically less than 2%.

IV. CONCLUSIONS

We have measured the energy loss due to hysteresis and eddy currents for both unipolar and bipolar ramp cycles, using a digital integration technique. We find good agreement between our results and the expected losses for a 40mm SSC model dipole. Our present measurement sensitivity is about 5%, and this is expected to be improved. In the future we will measure the AC losses of 50mm aperture SSC model dipoles, under various unipolar and bipolar ramp conditions, including ramp cycles designed specifically for the operation of the HEB of the SSC. These future results will help establish design guidelines for the HEB, by providing estimates of the energy losses associated with bipolar operation, and, therefore, the refrigeration requirements of the HEB.

We have also measured the magnetic field harmonics for both unipolar and bipolar ramps, and find that the hysteresis curves of the various multipoles studied to be identical under unipolar and bipolar operation. Since the harmonic content appears independent of ramp polarity, this will not be a factor in the bipolar operation of the HEB. In the future we will also perform harmonics measurements of 50mm model dipoles, using both standard and special HEB cycle ramps.

V. ACKNOWLEDGMENTS

We wish to thank the technical staff of the Superconducting Magnet R&D Facility, in particular D. Lewis and A. Rusy, for their assistance in performing these studies.

VI. REFERENCES

- 1.) Site Specific Conceptual Design, SSCL-SR-1056, July 1990.
- 2.) R. C. Bossert, et. al., "SSC 40mm Short Model Construction Experience", in *"IISSC, Supercollider 2"*, p. 483, M. McAshan, ed., Plenum Press, New York, NY (1990).
- 3.) S. A. Gourlay, "Summary of DS0315 Quench Performance", Fermilab Technical Support Section Memo TS-SSC 91-053.
- 4.) "Tevatron Low-B Quadrupole Specification", Sec. 1.3.1.6, Fermilab, February 15, 1990.
- 5.) M. N. Wilson, *Superconducting Magnets*, New York: Oxford University Press, 1983.
- 6.) A. D. McInturff and D. Gross, "Magnetization Characterization Study for the Energy Saver/Doubler Dipoles" in *Proceedings of the 1981 Particle Accelerator Conference*, Washington, D.C., March 1981.
- 7.) M. N. Wilson, "An Improved Technique for Measuring Hysteresis Loss in Superconducting Magnets", *Cryogenics*, June 1973.
- 8.) M. Wake, et. al., "AC Loss in Energy Doubler Magnets", *IEEE Trans. Magnetics*, Vol. 15, 1979.
- 9.) G. Snitchler, private communication.