

CHAPTER 364

BREAKWATER DAMAGE IN OKUSHIRI PORT DUE TO THE HOKKAIDO NANSEI-OKI EARTHQUAKE TSUNAMI

Katsutoshi KIMURA¹
Yuzo MIZUNO¹
Hiroichi TSURUYA²
Yasuyuki NAKAGAWA²

Abstract

A tsunami caused by the Hokkaido-Nansei-oki earthquake struck Okushiri Island and the southwest coast of Hokkaido damaging many port facilities. This paper describes typical breakwater damage at Okushiri Port and the applicability of Tanimoto's formula for tsunami wave forces on vertical walls based on prototype failure analyses and the result of numerical simulations. The armor stability and the rubble mound scourings were examined from the results of 3-D model tests at a scale of 1/15. The damage patterns at the narrow opening of breakwaters were reproduced by the tests. The necessary weight of armor blocks and foot-protection blocks for breakwater heads were calculated by the C.E.R.C. formula using averaged flow speed at the peak of tsunami.

Introduction

The Hokkaido Nansei-oki earthquake of July 12, 1993, had a Richter scale magnitude of 7.8, and generated a huge tsunami. Okushiri Island, 70 km from the seismic center, was struck by the tsunami. In addition to a death toll exceeding 200, the tsunami damaged many public facilities in the coastal areas and port facilities, mainly breakwaters.

In general, breakwater damage from tsunamis are classified into the following two patterns;

- Sliding of caissons by tsunami wave forces
- Scouring of rubble mound foundations at breakwater heads by the strong tsunami flows

-
- 1) Civil Engineering Research Institute, Hokkaido Development Bureau, 1-3 Hiragishi, Sapporo, 062, JAPAN
 - 2) Port and Harbour Research Institute, Ministry of Transport, 3-1-1 Nagase, Yokosuka, 239, JAPAN

The caissons of the Kawaragi breakwaters in Hachinohe Port were damaged along a total length of 328m in the 1968 Tokachi-oki Earthquake. Ito et al. (1968) analyzed the tsunami height by numerical simulations and confirmed that the difference in the water level between the inside and outside of the breakwater led to the damage. In Noshiro Port, the offshore seawalls of a power plant were heavily damaged by the 1983 Nihonkai-Chubu earthquake tsunami. Tanimoto et al. (1983) analyzed the tsunami wave forces based on the field survey and model tests. In Okushiri Port at the eastern side of Okushiri Island, similar damage patterns appeared in the north breakwater. In this paper, the relationship between the sliding distances and tsunami height is examined from the results of numerical simulations

The armor stability at the breakwater head is a very important factor for the design of tsunami protection breakwaters. Tanimoto et al. (1988) made the three-dimensional (3-D) model tests for the offshore breakwaters in Kamaishi Port, and proposed armor stability coefficients for practical design. A remarkable aspect of tsunami damage appeared at the narrow opening between the outer east breakwater and the east breakwater in Okushiri Port. The head caissons of both breakwaters

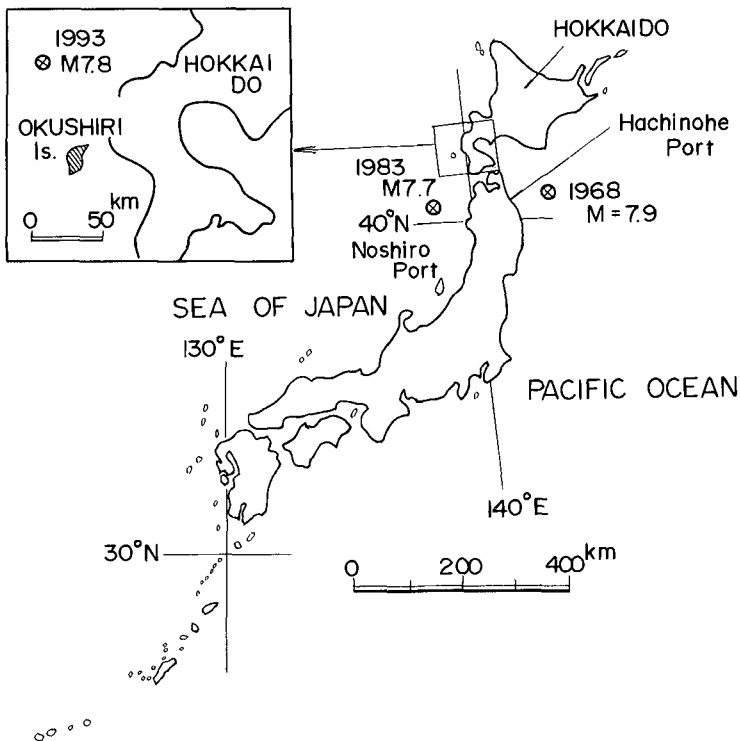

Figure 1. Location of Epicenter

collapsed due to scourings of rubble mound covered with armor blocks by the strong tsunami flow. To reproduce the damage pattern, large-scale 3-D hydraulic model tests were made at a model scale of 1/15. In this paper, the relationship between the flow speed and the damage ratio is examined from test results, and the applicability of armor stability coefficients is confirmed for the practical design of breakwaters against tsunamis.

Outline of breakwater damages

On 12 July 1993, a tsunami, caused by seismic disturbance at latitude $42^{\circ} 47'$ and longitude $139^{\circ} 12'$ struck Okushiri Island and along the southwest coast of Hokkaido. Figure 1 shows the location of the epicenter and Okushiri Island.

Okushiri Port on the eastern side of Okushiri Island is the only port of the island, and includes the ferry terminal to mainland Hokkaido. Figure 2 shows the breakwaters and port facilities in Okushiri port. The outer east breakwater and the east breakwater are the main barriers against wind waves. The opening between the outer east breakwater and the north breakwater is used for the main waterway, and a narrow opening between the outer east breakwater and the east breakwater is also used for a waterway for small craft.

Figure 3 shows the damage pattern of the north breakwater. Sections A, B, C, and D are caisson-type composite breakwaters, and section E is a concrete block type. According to the eyewitnesses, the tsunami waves propagated parallel to the shore line and attacked vertically against sections, C, D, and E of the north breakwater. In contrast, caissons slid little in sections A and B near the head of the breakwater.

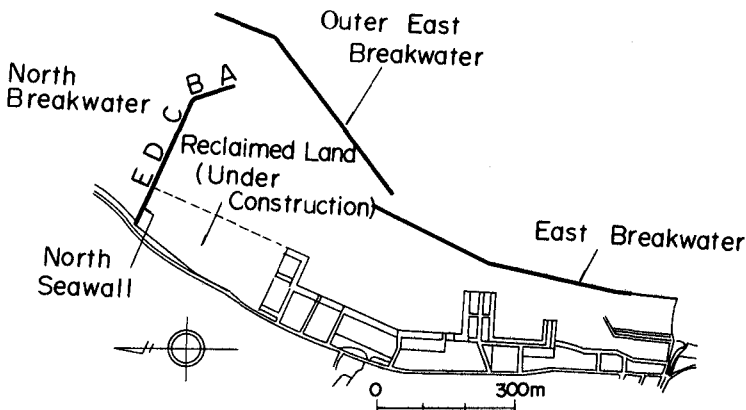

Figure 2. Breakwaters in Okushiri Port

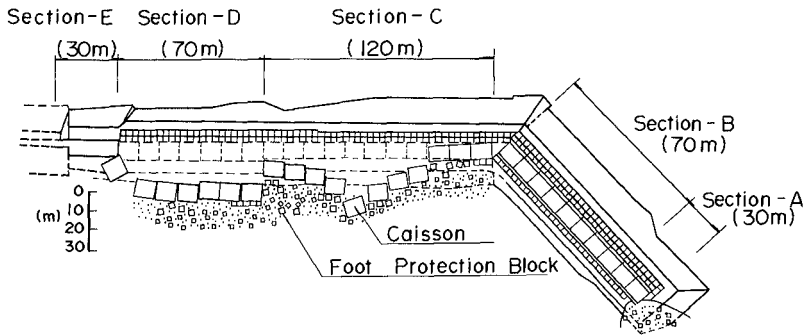

Figure 3. Caisson Sliding at the North Breakwater

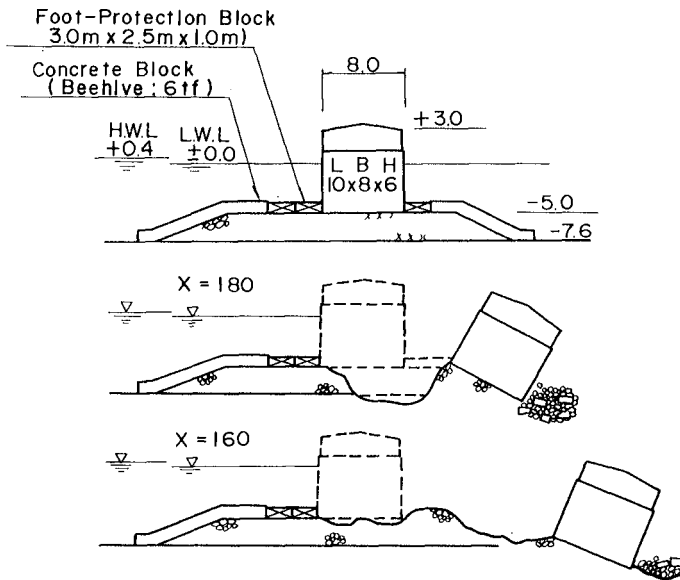

Figure 4. Damage Patterns of Section C of the North Breakwater

Figure 4 (upper diagram) shows a standard cross section of section C. The depth was 7.6m and the caisson was settled at a depth of 5.0m. Figure 4 (lower diagrams) shows typical damage patterns. At the position of X=180 m, the caissons slid 20m and pushed foot-protection blocks (3.0m long, 2.5m wide and 1.0m thick) and concrete blocks (6tf beehive). The scouring of rubble stones (30~300kg)

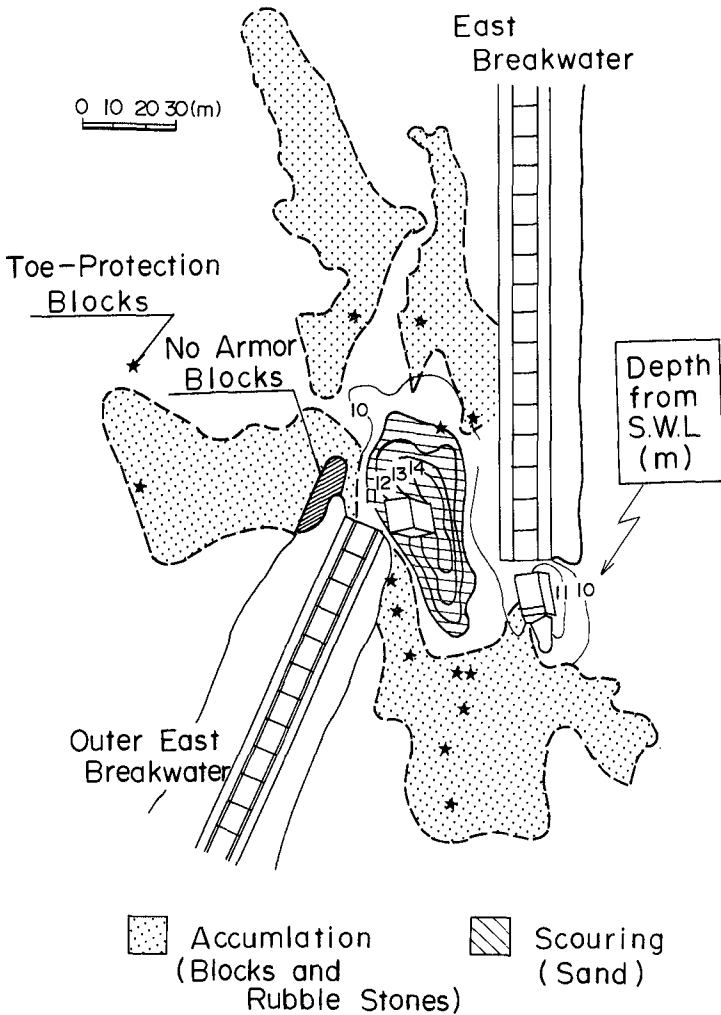

Figure 5. Scouring at the Narrow Opening

progressed along with the action of tsunami waves even after the caissons had slid, and mound rubble collected at $X = 160$ m.

Figure 5 shows the scouring at the narrow opening between the east and the outer east breakwaters. The width of the opening is 35m and the depth was 10m. Rubble mounds of both breakwaters were covered by concrete blocks (1 tf beehive) and foot-protection blocks (1.5m wide, 2.5m long and 1.5m thick). These armor

blocks were moved and scattered as shown in Fig. 5. The maximum scouring depth was 4 m from the original sea bed, and the head caissons at both breakwaters collapsed.

Tsunami forces on vertical walls

The lower part of Fig.6 shows the sliding distance S of each section in the north breakwater. The upright structures of Section E (seawalls for reclaimed land) were heavily damaged, because the sand fillings were not completed when the tsunami struck. Other sections were caisson breakwaters with depths of 5~11 m, and widths of 7.5~9.0 m.

Tanimoto (1983) proposed tsunami wave pressure distributions (Fig.7). The pressure intensity under the still water level p_1 and the crest tsunami height η^* can be calculated as follows:

$$p_1 = 2.2w_0a_I \quad \text{-----(1)}$$

$$\eta^* = 3.0a_I \quad \text{-----(2)}$$

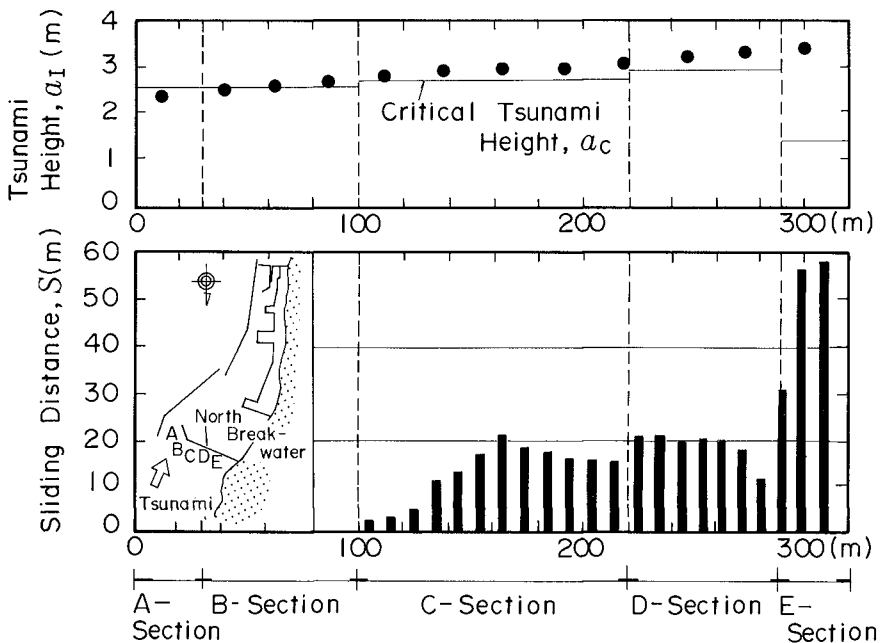

Figure 6. Tsunami Heights and Sliding Distances of the North Breakwater

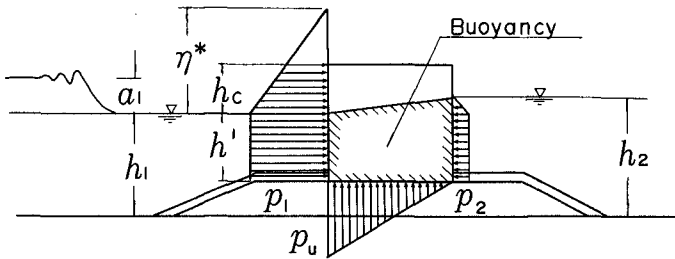

Figure 7. Tsunami Wave Pressure Distribution

where a_I is the incident tsunami height and w_0 is the unit weight of water. h_1 and h_2 are the depth at the offshore side and the harbor side, respectively.

The upper part of Fig.6 shows the critical tsunami heights a_c (horizontal lines) calculated by Tanimoto's formula, and the incident tsunami heights a_I (solid circles) estimated by 3-D numerical simulations. The sliding distances S increase when $a_I \geq a_c$, which confirms the applicability of Tanimoto's formula for prototype failures.

The distance between Okushiri Port and mainland Hokkaido is about 30km. Because the wind fetch is short, the design wave height for the breakwater H_{max} was 3.5 ~ 5.1 m. However, the design wave height in most ports and harbors facing the Sea of Japan exceeds H_{max} of 10 m. The small design wave height for Okushiri Port seems to have contributed to the extensive damages.

Experiments on scouring by strong tsunami flows

Large-scale hydraulic model tests with a scale of 1/15 were also made in the 3-D basin (50 m long, 20 m wide and 3.5 m deep) at the Port and Harbour Research Institute (Fig.8). Four axial flow pumps were installed in the basin so that tsunami waves could be reproduced by the action of the flow. By changing the rotation direction and cycles of the axial pumps, the flow direction and speed could be changed according to the analog signals.

The breakwater models were placed in the center of the basin (Fig.9). The scourings of rubble mounds and successive caisson failures at the narrow opening were reproduced. The depth was 66cm, the average depth of this area considering the tidal conditions. The upright section of breakwaters were made of reinforced concrete box (66.7cm long, 56.7cm wide and 73.3cm high) and their weights were adjusted by the filling materials. Concrete blocks (296gf beehive) and foot protection blocks (10cm wide, 16.7cm long and 6.7cm thick) were produced to scale. To facilitate the observations, concrete blocks were classified into four areas (Fig.9) and painted different colors.

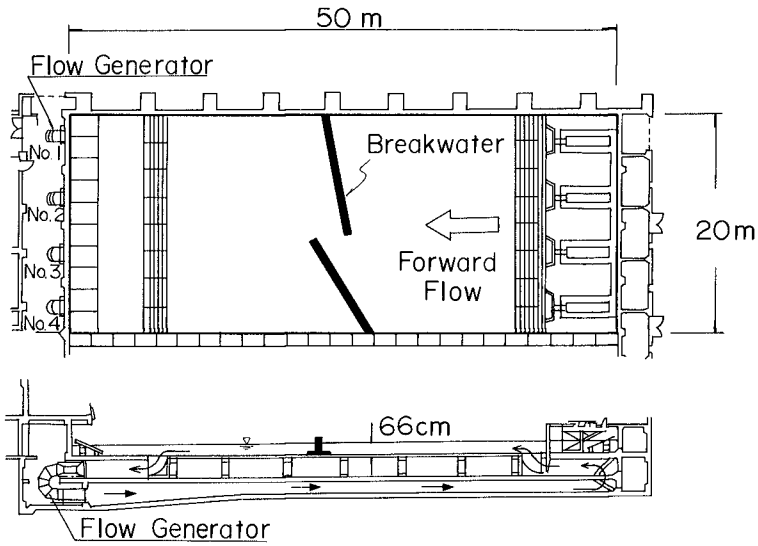

Figure 8. 3-D Basin with Flow Generators

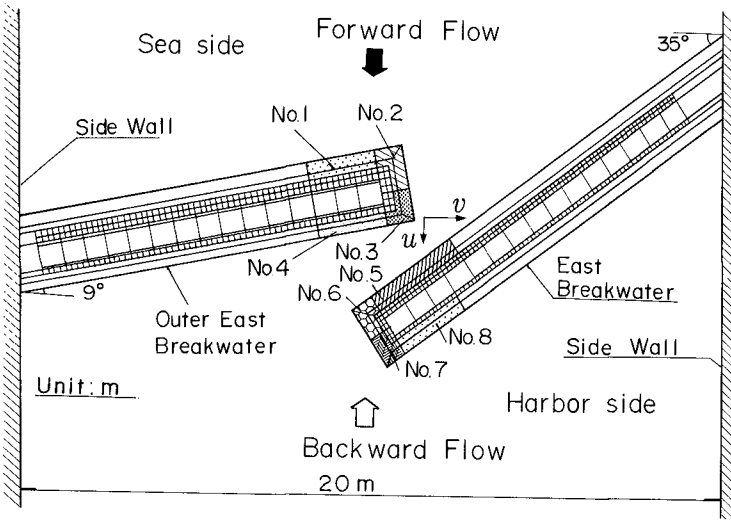

Figure 9. Breakwater Model in the 3-D Basin

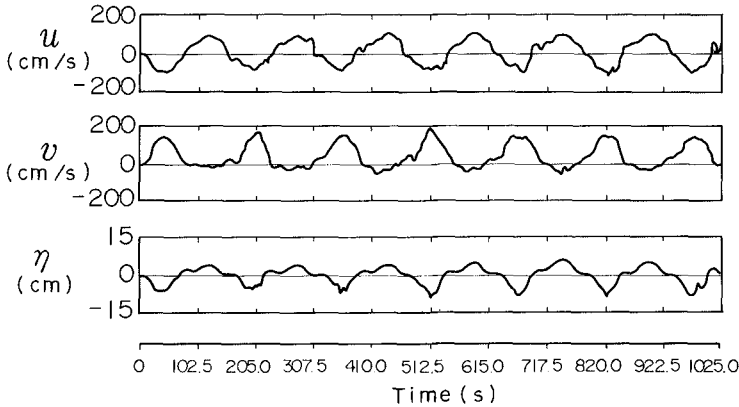

Figure 10. Flow and Water Level at the Center of Opening

Tsunami waves were simulated by generating oscillatory flows with the observed tsunami period of 10 minutes (prototype scale). The forward direction is defined as flow coming into the harbor. The flow speed was monitored at the center of the opening (Fig. 8) with a 2-D electromagnetic flow meter at the depth of 10 cm above the still water level. The peak flow speed of the tsunami (U_0) was defined as the square root of each flow components. The water level was also measured at the same point by a wave gauge.

Five kinds of tsunami flow with different peak speeds ($U_0 = 112, 151, 169, 180$ and 196 cm/s) were used for stability tests. How many tsunami waves attacked this area is not clear, but at least three waves are certain to have covered this area from information given by witnesses. In this experiment, tsunami waves corresponding to a duration of 6.5 times as long as the wave period were created to observe the displacement of the armor blocks and caissons. Figure 10 shows the flow and water level changes at $U_0 = 196$ cm/s.

Damage patterns around breakwater heads

Armor damage was found first at area No.3 in the outer east breakwater at a flow rate $U_0 = 151$ cm/s. The number of blocks moved was 18, and the damage ratio in this area was 20 %. The damage of foot-protection blocks was not observed at this flow rate. Tanimoto et al. (1988) examined the flow patterns at the mouth of tsunami protection breakwaters in 3-D model tests. They pointed out that the armor damage was heavier at the projecting head for the flow direction. In our experiment, the damage pattern for the forward flow was the same as for the experiments of Tanimoto. However, for the backward flow, no damage was observed at the area of No.7 of the east breakwater, probably because the opening ratio of our experiment was much lower than usual for tsunami protection breakwaters



Photo 1. Damaged Caisson and Mound of the Outer East Breakwater

At the flow rate $U_0=169$ cm/s (6.5 m/s in prototype), all armor blocks were damaged at the outer east breakwater and rubble stones were also scattered. At the east breakwater, 80% of the armor blocks were damaged. The damage of foot protection blocks was observed as 80% at the head of the outer east breakwater.

At the flow rate $U_0=196$ cm/s (7.6 m/s in prototype), the first tsunami wave scoured most of rubble stones around the head caissons, and the head caissons of both breakwaters tilted due to the scouring of the rubble mound. In the outer east breakwater, the damage progressed further to the head caisson failure by the second tsunami wave. The maximum flow rate at the failure was recorded to be 2.3 m/s (8.9 m/s in prototype). Photo 1 shows the damaged caisson and mound of the outer east breakwater after the experiment. The prototype damage around the breakwater heads as shown in Fig. 5 was successfully reproduced by these model tests.

Necessary weight of Armors

The weight required to withstand the flow can be calculated by the following Coastal Engineering Research Center (C.E.R.C.:1984) formula;

$$W = \frac{\pi w U_0^6}{48y^6 g^3 (w/w_0 - 1)^3 (\cos \theta - \sin \theta)^3} \quad (3)$$

where W is the weight of armor unit, U_0 is the flow speed, w_0 is the unit weight of fluid, w is the unit weight of armor units, g is the acceleration of gravity and θ is the angle of mound slope. This equation (3) is commonly accepted as giving the

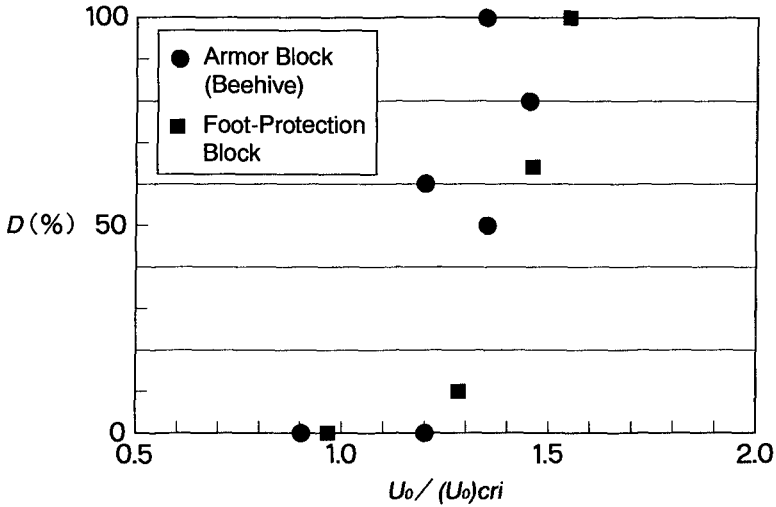

Figure 11. Damage Ratios of Armor Blocks and Foot-Protection Blocks

necessary weight of stones and armor blocks to withstand steady flows. Tanimoto et al.(1988) carried out the armor stability tests of tsunami protection breakwaters, and showed the applicability of this formula for tsunami flows.

Tsuruya et. al. (1994) recommended that the Isbash parameter γ for beehive blocks should be 1.2 in the actual settled condition, and 0.967 for individual blocks separately settled on the sea bottom. Kimura(1995) proposed that $\gamma=0.6\sim 0.7$ can be used based on the previous tsunami damage for foot-protection blocks.

In the 3-D model test for breakwater heads, damage ratios were also observed for each tsunami flows. Figure 11 shows the damage ratio of beehive and foot-protection blocks for $U_0=151, 169, 180$ and 196 cm/s. The critical flow speed $(U_0)_{cri}$ is calculated from Eq.(3) for beehive ($\gamma = 1.2$) and foot-protection block ($\gamma = 0.65$). Damage starts from $U_0/(U_0)_{cri} = 1.0$, and therefore the applicability of these coefficients is proved.

Conclusions

The damage analyses of breakwaters in Okushiri Port due to the 1993 Hokkaido Nansei-oki earthquake tsunami gave the following results and conclusions;

- The caisson breakwaters, whose design wave height due to storm waves were small, were damaged by the tsunami attack.
- The applicability of Tanimoto's formulae for tsunami forces on vertical walls was confirmed by the prototype failure analyses of the north breakwaters in Okushiri Port.

- The failure at breakwaters heads was reproduced by the 3-D model tests. The maximum flow speed of the tsunami was estimated as 8.9 m/s in the prototype.
- The necessary weight of armors around the head of breakwaters can be estimated by the C.E.R.C. formula using the Izbash parameter of previous model tests.

The 3-D experiment in this report did not reproduce the scouring of sandy sea beds. The sea bed was possibly scoured at a smaller flow velocity than indicated in this report, which resulted in the destruction of mounds and in turn led to the collapse of caissons at the breakwater head. Future studies should consider the influence of sediment movement.

Acknowledgments

The field survey on breakwater damages was made by the Port and Harbor Division of Hokkaido Development Bureau and the Cold Region Port and Harbor Engineering Research Center. The authors would like to express their gratitude to Professor N. Shuto at Tohoku University for advice on the numerical calculations on tsunami height.

References

- Coastal Engineering Research Center(1984): Shore Protection Manual, Volume II, pp.7-253.
- Ito, Y., Tanimoto, K., and Kihara, T.(1969): Desital computation on the effect of breakwaters against long-period waves(5th Report), Repot of Port and Harbour Res. Inst., Vol.8, No.3, pp.16~46.
- Kimura, K. (1995): Stability of rubble mound foundation for composite breakwaters against storm waves and tsunamis, Report of Civil Engineering Res. Inst., No. 110, pp. 82.
- Tanimoto, K.(1983): On the Hydraulic Aspects of Tsunami Breakwaters in Japan, Proc. of the International Tsunami Symposium by IUGG Tsunami Commission, pp.423~435.
- Tanimoto, K., et al. (1983): Field and laboratory investigations of tsunami caused by 1983 Nihonkai Chubu Earthquake, Technical Note of the Port and Harbour Res. Inst., No. 470, 299p.
- Tanimoto, K., Kimura, K., Ikegami, M. and Miyazaki, K. (1988): Study on stability of submerged dike at the opening section of tsunami protection breakwaters, Report of Port and Harbor Res. Inst., Vol.27, No.4, pp.93~121.

Tsuruya, H. and Nakagawa, Y. (1994): Model experiment for reproduction of disaster at Okushiri-Higashi breakwater by Hokkaido-Nanseioki earthquake Tsunami, Technical Note of the Port and Harbour Res. Inst., No.789, 19p.