

## **BROADBAND STACKED U-SLOT MICROSTRIP PATCH ANTENNA**

**J. A. Ansari and R. B. Ram**

Department of Electronics and Communication  
University of Allahabad  
Allahabad-211002, India

**Abstract**—A broadband stacked U-slot microstrip patch antenna is presented using circuit theory concept. The antenna shows two resonance frequencies that are very closely spaced to give broadband characteristics. The frequency band of 186 MHz (36.4% impedance bandwidth) is achieved for the proposed antenna. The theoretical results are in good agreement with the simulated results.

### **1. INTRODUCTION**

Microstrip antennas have become attractive candidates in a variety of commercial applications such as mobile and satellite communications. Traditionally, microstrip antennas suffer from low bandwidth characteristic. Experimentally and theoretically, it has been shown that a coaxially fed patch antenna on a foam substrate of approximately 0.08 wavelength thick can enable an impedance bandwidth of about 33%, by cutting proper U-slot in the patch [1, 2]. Moreover, Lee and Lee [3] have experimentally demonstrated the characteristics of two-layer electro-magnetically coupled rectangular patch and reported that relatively large bandwidth could be obtained when the separation between the two layers was less than 0.15 wavelength. Therefore, in the present paper, a stacked U-slot microstrip antenna is presented for broadband operation. The modal expansion cavity model and circuit theory concept have been used to analyze the antenna characteristics. The details of theoretical investigations are given in the following sections.

### **2. THEORETICAL CONSIDERATIONS**

The geometry of the proposed antenna is shown in Figure 1. The lower patch is rectangular patch with dimensions  $L_d = 25$  mm and

$W_d = 30$  mm and it is printed on a grounded substrate of thickness  $h_1 = 1.59$  mm and dielectric constant  $\epsilon_{r1} = 2.17$ . A U-slot with dimensions arm-length  $L_s = 16.50$  mm, base-length  $W_s = 12.50$  mm and slot-width  $S = 2.5$  mm is cut in the patch in such a way that the side arms of U-slot are symmetrically positioned with respect to the feed point. The upper square patch has dimensions  $L_p = W_p = 18$  mm that is etched on a substrate of thickness  $h_2 = 1.59$  mm and dielectric constant  $\epsilon_{r2} = 2.17$ . The upper parasitic patch is separated from lower fed patch by air-gap spacing ( $h_a = 3.50$  mm) introduced by a foam material of dielectric constant  $\epsilon_{ra} = 1$ .

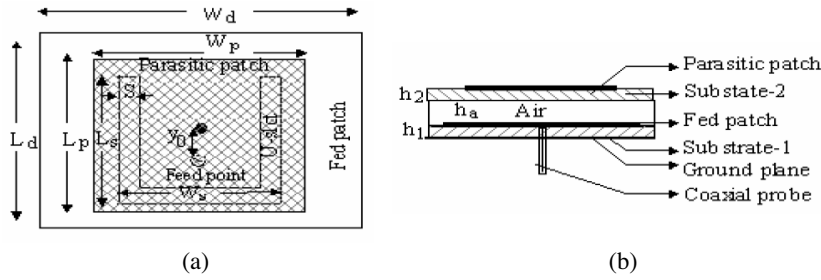

**Figure 1.** Geometry of the proposed antenna. (a) Top view and (b) side view.

When lower patch is coaxially fed at  $y_0 = 6.15$  mm, the upper parasitic patch is electro-magnetically, coupled to the lower fed patch through the air-gap that is realized by current distribution at frequency 4.09 GHz as shown in Figure 2.

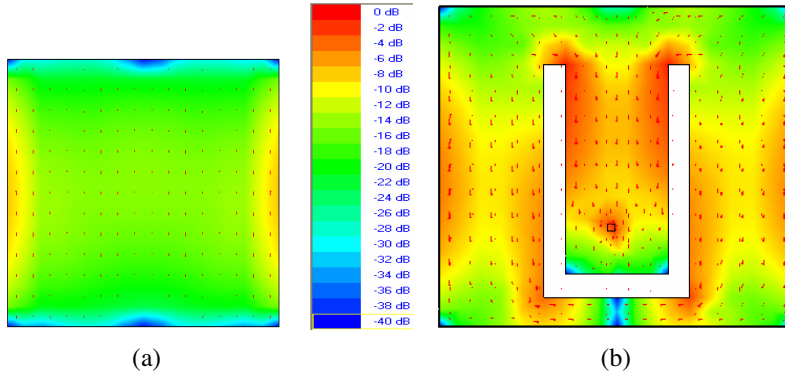

**Figure 2.** Current distribution at 4.09 GHz. (a) Upper patch. (b) Lower patch.

Due to presence of the parasitic patch in the stacked configuration, there are two resonances associated with the two constitutive resonators. One resonance is associated with resonator formed by the lower patch and ground plane. The second resonance is associated with the resonator formed by the upper patch and the lower patch. The effective dielectric constant of the antenna structure can be calculated as [4]

$$\varepsilon_{re} = \frac{h_1 + h_2 + h_3}{\frac{h_1}{\varepsilon_{r1}} + \frac{h_a}{\varepsilon_{ra}} + \frac{h_2}{\varepsilon_{r2}}} \quad (1)$$

The effective dielectric constant of substrate-1, can be expressed as

$$\varepsilon_{ed} = \frac{\varepsilon_{re} + 1}{2} + \frac{\varepsilon_{re} - 1}{2} \left[ 1 + \frac{10h_1}{L_d} \right]^{-1/2} \quad (2)$$

Therefore, the resonance frequency of the lower patch of the stacked antenna can be expressed [5]

$$fr_1 = \frac{c}{2L_d\sqrt{\varepsilon_{ed}}} \frac{1 - A}{1 + A \ln \left( \frac{1.123L_d\sqrt{\varepsilon_{ed}}}{h_1} \right)} \quad (3)$$

where  $c$  is the velocity of light in free space, and

$$A = \frac{2}{\pi\varepsilon_{ed} \left[ \frac{L_d}{h_1} + 1.393 + 0.667 \ln \left( \frac{L_d}{h_1} + 1.444 \right) \right]}$$

The resonance frequency of the upper patch can be given as

$$fr_2 = \frac{c}{2(L_p + \Delta L_p)\sqrt{\varepsilon_{ep}}} \quad (4)$$

where  $\Delta L_p$  is the line extension of the upper patch, and  $\varepsilon_{ep}$  is the effective dielectric constant of substrate-2 that can be calculated using Equation (2) for the upper patch.

The U-slot cut in the lower patch can be considered as a combination of three narrow slots joint together in the form of U-shape. Using duality relationship of dipole and slot, the equivalent circuit of U-slot can be represented as shown in Figure 3(a). Here,  $R_{UH}$ ,  $X_{UH}$  and  $R_{VH}$ ,  $X_{VH}$  are radiation resistance and reactive component of the base-arm and side-arm of the U-slot that can be calculated as [6]. According to the modal expansion cavity model [7], a patch can be characterized by a parallel combination of resistance, inductance,

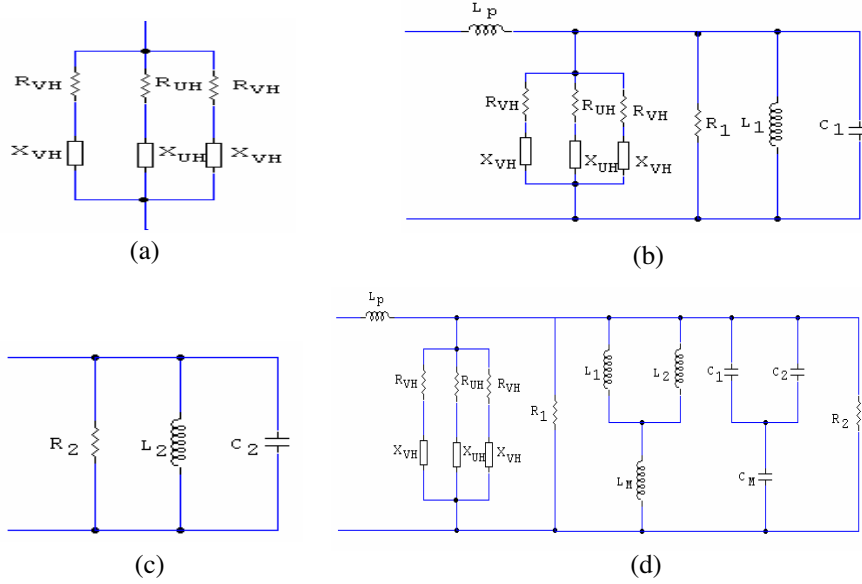

**Figure 3.** Equivalent circuits of (a) U-slot. (b) Lower patch with u-slot. (c) Upper patch and (d) proposed antenna.

and capacitance. Therefore, the equivalent circuit of the lower and upper patches can be given as shown in Figure 3(b) and Figure 3(c) respectively. When a coaxial probe feeds the lower patch, the upper patch is electro-magnetically coupled to the lower patch. As a result of this coupling, two closed and distinct resonance frequencies appears in the antenna to give broadband operation. Thus the equivalent circuit of the proposed antenna can be given as shown in Figure 3(d). In the equivalent circuit shown in Figure 3(d), one can take

$$Z_{UH} = R_{UH} + jX_{UH} \quad (5)$$

$$Z_{UV} = R_{VH} + jX_{VH} \quad (6)$$

$$R = \frac{R_1 R_2}{R_1 + R_2} \quad (7)$$

$$L = \frac{L_1 L_2}{L_1 + L_2} + L_M \quad (8)$$

and

$$C = \frac{(C_1 + C_2)C_M}{C_1 + C_2 + C_M} \quad (9)$$

where,  $R_1$ ,  $L_1$ ,  $C_1$ ; and  $R_2$ ,  $L_2$ ,  $C_2$  are the resistance, inductance, and

capacitance of lower patch (without slot) and upper patch respectively.  $L_M$  and  $C_M$  are the mutual inductance and capacitance due to electromagnetic coupling between the two patches.

Hence the input impedance of the antenna can given as

$$Z_{IN} = \frac{1}{\frac{1}{Z_U} + \frac{1}{R} + j\omega C + \frac{1}{j\omega L}} \quad (10)$$

where

$$Z_U = \frac{Z_{UV} + 2Z_{UH}}{Z_{UV}Z_{UH}} \quad (11)$$

The reflection coefficient ( $\rho$ ) of the antenna is given as

$$\rho = \left| \frac{Z_{in} - Z_0}{Z_{in} + Z_0} \right| \quad (12)$$

where  $Z_0$  is the characteristic impedance of the coaxial feed line (50 ohm).

Therefore, the return loss ( $RL$ ) of the antenna is given as

$$RL = 10 \log \left( \frac{1}{\rho^2} \right) \quad (13)$$

Since for the far-field radiation, the distance between fed patch and parasitic patch is very small as compared to the far field point, therefore the radiations from the two patches can be considered in the same phase. Also the slot voltage induced in the parasitic patch is  $c_c$  times the slot voltage of the driven patch. Therefore, the radiation field for the proposed antenna for far field radiation can be written as

$$E(\theta) = E_d(\theta) + E_p(\theta) \quad (14)$$

and

$$E(\phi) = E_d(\phi) + E_p(\phi) \quad (15)$$

where the radiation fields  $E_d$  and  $E_p$  for driven and parasitic patches are given as [8]

$$E_d(\theta) = -\frac{jk_0 W_d V_0 e^{-k_0 r}}{\pi r} \cos(k_0 h_1 \cos \theta) \left\{ \frac{\sin(k_0 W_d \sin \phi \sin \theta)}{2} \right\} \cos \left\{ \frac{k_0 (L_d + \Delta L_d)}{2} \sin \theta \sin \phi \right\} \cos \theta \sin \phi \quad (16)$$

$$E_d(\phi) = -\frac{jk_0 W_d V_0 e^{-k_0 r}}{\pi r} \cos(k_0 h_1 \cos \theta) \left\{ \frac{\sin(k_0 W_d \sin \phi \sin \theta)}{2} \right\} \cos \left\{ \frac{k_0 (L_d + \Delta L_d)}{2} \sin \theta \sin \phi \right\} \cos \phi \quad (17)$$

$$E_p(\theta) = -\frac{jk_0 W_p V_0 e^{-k_0 r}}{\pi r} \cos(k_0 (h_1 + h_a) \cos \theta) \left\{ \frac{\sin(k_0 W_p \sin \phi \sin \theta)}{2} \right\} \cos \left\{ \frac{k_0 (L_p + \Delta L_p)}{2} \sin \theta \sin \phi \right\} \cos \theta \sin \phi \quad (18)$$

$$E_p(\phi) = -\frac{jk_0 W_p V_0 e^{-k_0 r}}{\pi r} \cos(k_0 (h_1 + h_a) \cos \theta) \left\{ \frac{\sin(k_0 W_p \sin \phi \sin \theta)}{2} \right\} \cos \left\{ \frac{k_0 (L_p + \Delta L_p)}{2} \sin \theta \sin \phi \right\} \cos \phi \quad (19)$$

where  $V_0$  is the radiating edge voltage,  $r$  is the distance of an arbitrary far-field point and  $k_0$  is the propagation constant in free space.

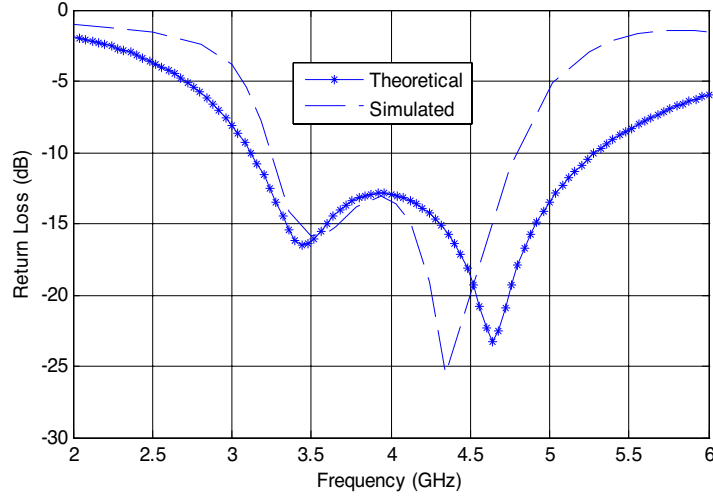

**Figure 4.** Variation of return loss with frequency.

### 3. CALCULATIONS AND DISCUSSION OF RESULTS

The calculations for return loss of the antenna were carried out using Equation (13); the resulting data are shown in Figure 4. It depicts the antenna has two resonance frequencies, one at 3.44 GHz and other at 4.60 GHz. These two resonance frequencies are closely spaced to give broadband characteristic. The frequency band of operation is obtained approximately equal to 186 MHz for return loss values less than 10 dB. The antenna shows an impedance bandwidth of 36.40%.

On the other hand, simulated result shows 33.89% impedance bandwidth. Thus theoretical results are in good agreement with the simulated results and therefore, the validity of the proposed method is justified.

The data for  $E$ -plane radiation pattern of the proposed antenna at frequency 4.09 GHz, were calculated using Equations (14) & (15), the data so obtained are shown in Figure 5. It is observed that the 3 dB beam width of the antenna is  $52.4^\circ$ .

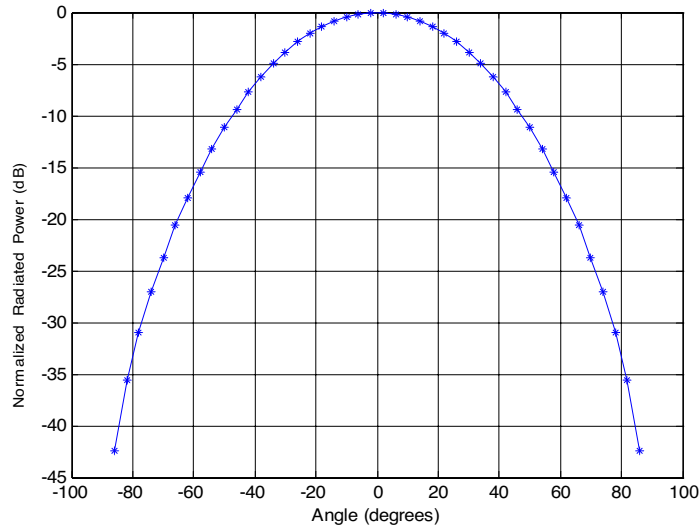

**Figure 5.**  $E$ -plane radiation pattern.

### 4. CONCLUSIONS

It is, therefore, concluded that the proposed antenna is suitable for various communication systems that require operating frequency band of 186 MHz (bandwidth 36.40%).

## REFERENCES

1. Huynh, T. and K. F. Lee, "Single layer single patch wideband microstrip antenna," *Electronics Letters*, Vol. 31, No. 16, 1310–1312, 1995.
2. Lee, K. F., K. M. Luk, K. F. Tong, S. M. Shum, T. Huynh, and R. Q. Lee, "Experimental and simulation studies of the co-axially fed U-slot rectangular patch antenna," *IEE Proc. Microw. Antenna Propag.*, Vol. 144, No. 5, 354–358, 1997.
3. Lee, R. Q. and K. F. Lee, "Experimental study of the two layer electro magnetically coupled rectangular patch antenna," *IEEE Trans. Antenna Propag.*, Vol. 38, No. 8, 1298–1302, 1990.
4. Liu, Z. F., P. S. Kooi, L. W. Li, M. S. Leong, and T. S. Yeo, "A method for designing broad band microstrip antennas in multilayered planar structures," *IEEE Trans. Antenna Propag.*, Vol. 47, No. 9, 1416–1420, 1999.
5. Pues, H. and A. Van de Capelle, "Accurate transmission line model for the rectangular microstrip antenna," *IEE Proc. - Micro. Antenna Propag.*, Vol. 133, Pt. H., 334–340, 1984.
6. Ansari, J. A. and R. B. Ram, "Analysis of broad band U-slot microstrip patch antenna," *Microw. Opt. Tech. Lett.*, Vol. 50, No. 4, 1069–1073, 2008.
7. Bahl, J. and P. Bhartia, *Microstrip Antennas*, Artech House, Dedham, 1980.
8. Carver, K. R. and J. W. Mink, "Microstrip antenna technology," *IEEE Trans. Antenna Propag.*, Vol. 29, No. 1, 1–24, 1999.