



Building a Loosely Timed SoC Model with OSCI TLM 2.0

**A Case Study Using an Open
Source ISS and Linux 2.6 Kernel**

Jeremy Bennett
Embecosm

Application Note 1. Issue 1
June 2008



Legal Notice

This work is licensed under the Creative Commons Attribution 2.0 UK: England & Wales License. To view a copy of this license, visit <http://creativecommons.org/licenses/by/2.0/uk/> or send a letter to Creative Commons, 171 Second Street, Suite 300, San Francisco, California, 94105, USA.

This license means you are free:

- to copy, distribute, display, and perform the work
- to make derivative works

under the following conditions:

- *Attribution.* You must give the original author, Embecosm (www.embecosm.com), credit;
- For any reuse or distribution, you must make clear to others the license terms of this work;
- Any of these conditions can be waived if you get permission from the copyright holder, Embecosm; and
- Nothing in this license impairs or restricts the author's moral rights.

The software examples written by Embecosm and used in this document are licensed under the GNU Lesser General Public License (GNU Lesser General Public License). For detailed licensing information see the files **COPYING** and **COPYING.LESSER** in the source code of the examples.

Embecosm is the business name of Embecosm Limited, a private limited company registered in England and Wales. Registration number 6577021.



Table of Contents

1. Introduction	4
1.1. Target Audience	5
1.2. About the Embecosm TLM 2.0 Application Notes	5
2. Background to SystemC and the TLM 2.0 Standard	5
2.1. What is SystemC	6
2.2. What is a TLM	6
2.3. Overview of OSCI TLM 2.0	7
3. Case Study: A Loosely Timed SoC Using TLM 2.0	10
3.1. The Example Designs	11
3.2. Example Code	13
4. Wrapping the ISS	14
4.1. Modifying the Or1ksim ISS for TLM 2.0	15
4.2. Or1ksim Wrapper Module Class Definition	16
4.3. Or1ksim Wrapper Module Class Implementation	18
5. Testing the Or1ksim ISS TLM 2.0 Wrapper	21
5.1. Definition of the TLM 2.0 Logger Module	22
5.2. Implementation of the TLM 2.0 Logger Module	22
5.3. The Model Main Program	24
5.4. Test Program to Run on the Or1ksim	24
5.5. Running the Test	26
6. Modeling Peripherals	28
6.1. Details of the 16450 UART	29
6.2. UART Module Design	30
6.3. Extending the Or1ksimSC Wrapper Module	31
6.4. UART: Module Class Definition	32
6.5. UART Module Class Implementation	34
7. Adding a Terminal as a Test Bench	37
7.1. SystemC Terminal Module Design	38
7.2. Terminal Module Class Definition	38
7.3. Terminal Module Class Implementation	39
7.4. The Complete SoC	40
8. Adding Synchronous Timing to the Model	45
8.1. Summary of Changes Required for Synchronous Timing	46
8.2. Extending the Or1ksimExtSC Wrapper Module	46
8.3. Extending the UartSC Module Class	48
8.4. Extending the TermSC Module Class	50
8.5. Main Program for the Synchronous Model	51
8.6. Compiling and Running the Synchronous Model	52
9. Adding Temporal Decoupling to the Model	53
9.1. What is Temporal Decoupling	54
9.2. Guidelines for Using TLM 2.0 Temporal Decoupling	57
9.3. Temporal Decoupling the Or1ksim Wrapper Class	57
9.4. Modifying the UART to Support Temporal Decoupling	59
9.5. Main Program for Temporal Decoupling	60
9.6. Compiling and Running the Synchronous Model	60
10. Modeling Interrupts and Running Linux on the Example SoC	62
10.1. Extending the Or1ksimDecoupSC Module Class	63
10.2. Extending the UartDecoupSC Module Class	64
10.3. Main Program for the Interrupt Driven Model	65
10.4. Running the Interrupt Driven Model	66
A. Downloading the Example Models	68



A.1. Patching Orlksim	69
A.2. Building the Linux Kernel	69
Glossary	69
References	74



1. Introduction

The Open SystemC Initiative (OSCI) has recently issued the second version of its standard for Transaction Level Modeling (TLM) [4]. This defines an interface for writing high level software models of hardware.

The OSCI standard is comprehensive. As well as a powerful general purpose interface, it defines a number of *convenience* components to facilitate adoption of the technology.

This application note provides an introductory tutorial on using TLM 2.0 for loosely timed models—ideally suited for early development of embedded software. It demonstrates through a practical case study the development of a complete SoC, capable of running a modern Linux 2.6 kernel, using the TLM 2.0 *convenience* components.

One of the most important components in any SoC system model is the processor core Instruction Set Simulator (ISS). This application note demonstrates how to wrap an existing ISS to provide a TLM 2.0 compliant interface.

This application note is the first in a series from Embecosm (www.embecosm.com), providing case studies in OSCI TLM 2.0 use. The objective is to provide an introduction to TLM 2.0 within a practical context. Examples are provided throughout, based on open source components, which are freely reusable under the GNU Lesser General Public License.

1.1. Target Audience

SystemC represents a challenge to engineers, because it bridges the divide between the worlds of hardware and software. These are two distinct disciplines, the languages of hardware design such as Verilog and VHDL are very different in philosophy to the languages of software development such as C++ and Java. Yet both are brought together in the world of the System on Chip SoC, where large embedded software systems must run on complex silicon chips often containing multiple processor cores of different architectures.

This application note is aimed at any engineer intending to bridge the gap between hardware and software. It recognizes that the reader will most likely be expert in only one of these. Explanation is provided throughout of both the hardware ideas and software ideas being covered.

The reader is assumed to have basic programming familiarity with C and C++ and the key concepts of object oriented programming: classes and instances of classes. A basic understanding of system level hardware design and the construction of SoC from components linked by buses (or on-chip networks).

Familiarity with SystemC is assumed. The user guide supplied with SystemC provides a good introduction [5].

1.2. About the Embecosm TLM 2.0 Application Notes

The OSCI TLM 2.0 standard represents a significant advance in standardizing the creation of fast models of hardware.

However the OSCI reference implementation lacks training material and examples to introduce new users to the technology.

This series of Embecosm Application Notes was prompted by a customer requesting assistance in porting an existing ISS to the TLM 2.0 standard. This is the first application note in the series. Further Embecosm Application Notes, addressing different aspects of TLM 2.0 will be published in the future.

2. Background to SystemC and the TLM 2.0 Standard

The development of SystemC as a standard for modeling hardware started in 1996. Version 2.0 of the proposed standard was released by the Open SystemC Initiative (OSCI) in 2002. In 2006, SystemC became IEEE standard 1666-2005 [3].

OSCI has several groups working on supplementary standards. One of these is the TLM Working Group. It proposed its first standard for transaction level modeling in 2005. Two drafts for version 2.0 were released in 2006 and 2007, with the version 2.0 standard issued in June 2008 [4].

2.1. What is SystemC

Most software languages are not particularly suited to modeling hardware systems¹. SystemC was developed to provide features that facilitate hardware modeling, particularly the parallelism of hardware, in a mainstream programming language.

An important objective was that software engineers should be comfortable with using SystemC. Rather than invent a new language, SystemC is based on the existing C++ language. SystemC is a true super-set of C++, so any C++ program is automatically a valid SystemC program.

SystemC uses the template, macro and library features of C++ to extend the language. The key features it provides are:

- A C++ class, **sc_module**, suitable for defining hardware modules containing parallel processes²;
- A mechanism to define functions modeling the parallel threads of control within **sc_module** classes;
- Two classes, **sc_port** and **sc_export** to represent points of connection a **sc_module**;
- A class, **sc_interface** to describe the software services required by a **sc_port** or provided by a **sc_export**;
- A class, **sc_prim_channel** to represent the channel connecting ports;
- A set of derived classes, of **sc_prim_channel**, **sc_interface**, **sc_port** and **sc_export** to represent and connect common channel types used in hardware design such as signals, buffers and FIFOs; and
- A comprehensive set of types to represent data in both 2-state and 4-state logic.

The full specification is 441 pages long [3]. The OSCI reference distribution includes a very useful introductory user guide and tutorial [5].

2.2. What is a TLM

2.2.1. Hardware and Software Views of Parallelism

To understand transaction level modeling, it is essential to understand the difference in approach to parallelism taken in hardware and software design.

A hardware engineer, typically writing in a Hardware Description Language (HDL) such as Verilog or VHDL, describes a design as a collection of parallel activities, which communicate

¹ There are some exceptions, most notably Simula67, one the languages which inspired C++. In some respects it is remarkably like SystemC.

via shared data. The parallel activities are **always** (Verilog) or **process** (VHDL) blocks. The shared data structures are wires or signals.

This follows very naturally the way that physical hardware behaves. There is no one *flow of control*—all parallel components are active at the same time, with their individual flow of control.

By contrast, a software engineer typically describes parallelism in a design as a number of threads, which pass flow of control between them. The threads communicate by a number of mechanisms (message passing or remote procedure call for example), but although there is *logical* parallelism, only one thread is ever physically active at one time.

This follows naturally the behavior on a conventional uni-processor CPU, where there is a single program counter indicating the next instruction to execute, and so only one flow of control. Even with modern multiprocessors, this is still a natural way of programming for the software engineer, because the number of threads or processes will often exceed the number of processor cores available.

2.2.2. Modeling Hardware Parallelism in Software

A simple way to model hardware is via a round-robin, which updates the state of each component as time advances. Each component is represented as a software function. A master clock function calls each component function in turn when the clock advances—for example on each clock edge. The wires between the components are represented as variables shared between the components. A number of tools (e.g. ARC VTOC, ARM RealView SoC Designer, Carbon SpeedCompiler, Verilator) use this approach to cycle accurate modeling.

With its close parallel of the way hardware is designed with languages such as Verilog and VHDL, this approach has merit for detailed modeling. It is well suited to cycle accurate modeling where every hardware register and wire must be accurate.

Efficiency demands that not every HDL **process** or **always** is built as a separate function. Automated tools which generate cycle accurate models in SystemC from HDL can often reduce complex designs to a small number of functions executed on each cycle.

For less detailed models, the overhead in calling each component whenever time advances cannot be justified.

The solution is to model each component only when it has something to do. The individual components communicate by sending messages requesting data be transferred between each other. The exchange of messages is called a transaction, and the approach Transaction Level Modeling (TLM).

This mirrors the way hardware behaves at the high level, where functional blocks communicate by reading and writing across buses.

2.3. Overview of OSCI TLM 2.0

OSCI TLM 2.0 offers a standard approach to building Transaction Level Models.

At the simplest level a TLM is a set of SystemC modules (i.e. C++ classes), each providing one or more sockets through which the SystemC modules may read and write data.

The behavior of each module is provided by a number of parallel threads (functions of the C++ class), which communicate with the threads in other modules by passing data (i.e. reading or writing) through the sockets. This communication is known as a transaction and the data passed as a payload. Figure 1 shows the key components in a TLM 2.0 model.

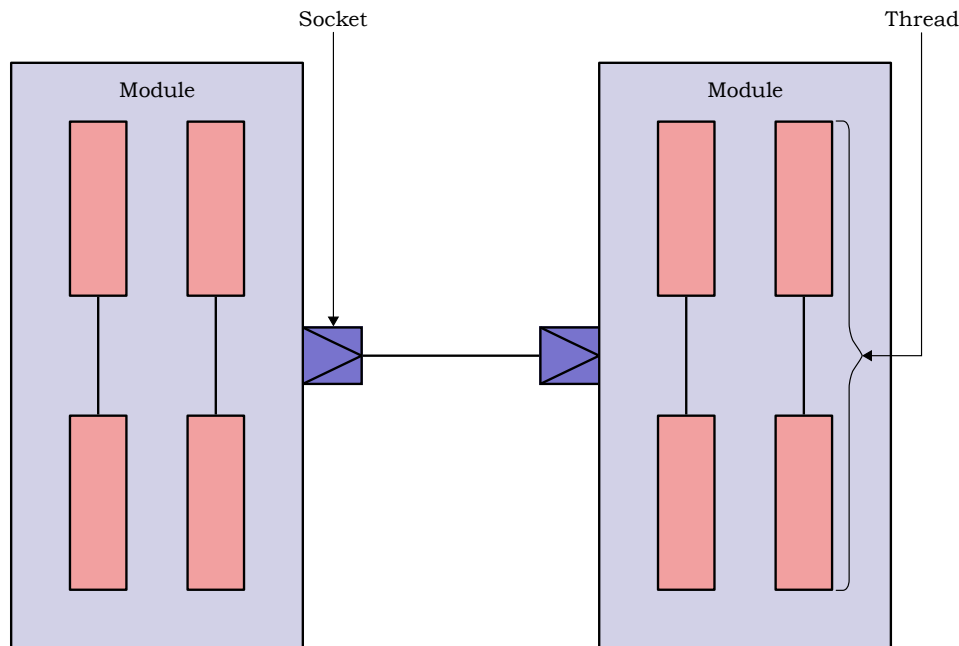

Figure 1. Key components in an OSCI TLM 2.0 model.

2.3.1. Transaction Payload

The data passed in a transaction may take any form. However the TLM 2.0 standard defines a Generic Payload which is suitable for many uses, and which can be extended if required. By using the Generic Payload, a TLM 2.0 model will maximize interoperability.

The main features of the Generic Payload are:

Command	Is this a read or a write?
Address	What is the address (in the hardware sense of an address in memory).
Data	A pointer to the physical data as an array of bytes
Byte Enable Mask	A pointer to an array indicating which bytes of the data are valid.
Response	An indication of whether the transaction was successful, and if not the nature of the error.

Further features provide support for streaming, custom memory management and extensions to the generic payload.

A TLM 2.0 transport function is used to pass the payload to another SystemC thread and obtain a response—i.e. a transaction.

2.3.2. Initiators and Targets

A module's threads may act as either initiators or targets. An initiator is responsible for creating a payload (see Section 2.3.1) and calling the transport function to send it. A target receives payloads from the transport function for processing and response. In the case of non-blocking interfaces (see Section 2.3.3, the target may create new transactions backwards in response to a transaction from an initiator.

Initiator calls are made through initiator sockets, target calls received through target sockets. A module may implement both target and initiator sockets, allowing its threads to both generate and receive traffic.

2.3.3. Blocking, Non-Blocking, Debug and Direct Memory Interfaces

There are two principal types of TLM 2.0 transport function.

1. The blocking transport functions are called by the initiator thread, received by the target thread, which processes the request and then returns the result. Until the transaction has been processed and released the initiator thread is blocked.
2. The non-blocking transport functions are called by the initiator thread, received by the target thread, which immediately returns, before processing the request. Subsequently the target, having processed the request makes a transport call *backwards* to the initiator to return the result.

In the non-blocking case there are actually two types of transport used. The forward transport path is used by the initiator to pass the request to the target and the backward transport path used by the target to return the response. The advantage of the non-blocking transport interface is that the initiator can carry on processing, while the target is processing the request originally made.

In addition TLM 2.0 provides two more specialized types of transaction.

1. A *debug transaction* is a read that does not affect the state of the model. These are for use by debuggers, which wish to see the state of a model, without affecting that state.
2. TLM 2.0 recognizes that a full-blown transaction is too heavyweight for some types of access. For example an ISS accessing memory using transactions would destroy performance. TLM 2.0 provides the concept of a direct memory interface, allowing threads direct access to blocks of memory in another thread for high performance.

2.3.4. Loosely Timed, Approximately Timed and Untimed TLM

TLM 2.0 considers two levels of timing detail.

1. A loosely timed model uses transactions corresponding to a complete read or write across a bus or network in physical hardware. It provides timing at the level of the individual transaction.
2. An approximately timed model breaks down transactions into a number of phases corresponding much more closely to the phasing of particular hardware protocols (for example the address and data phases of an AHB read or write).

Typically loosely timed models are implemented with a blocking interface and approximately timed models with a non-blocking interface.

TLM 2.0 also introduces the concept of temporal decoupling. Standard SystemC keeps a single synchronized view of time, which is used by all threads in all modules. However with temporal decoupling, each thread can keep its own local view of time, allowing the thread to run ahead in simulation time, until it needs to synchronize with another thread. This improves performance in loosely timed models with blocking interfaces, by avoiding bottlenecks in processing.

To ensure that one thread doesn't run away hogging all the processing, TLM 2.0 temporal decoupling uses the concept of the quantum, the greatest amount that a thread may differ in timing from the central view of time. This allows other threads a chance to catch up

TLM 2.0 does not have an explicit concept of an untimed socket (something that was explicit in TLM 1.0). The standardization group took the view that in practice all models need some concept of time, so purely untimed models are of little value.

However, untimed models are easily implemented as loosely timed models which always set the timing parameter in transport calls to zero. The example in Section 4 Section 6 and Sec-

tion 7 uses this approach to create an untimed model. This is then refined in Section 8 to add synchronous timing information and in Section 9 to add temporal decoupling.

2.3.5. TLM 2.0 Convenience Sockets

The standard TLM 2.0 approach to modeling requires the user to derive their own classes from the standard TLM 2.0 sockets, so that those sockets can then implement the TLM 2.0 interfaces. Modules then instantiate these derived sockets and use the bind function to connect them to sockets on other modules.

This is a very flexible approach, but the need to define new derived classes for sockets is an unnecessary layer of complexity for simple modeling. For such uses, the TLM 2.0 standard defines a number of convenience sockets which can be instantiated directly by modules, and which specify their interface functions as callbacks.

These convenience sockets are used throughout the case study in this application note.

3. Case Study: A Loosely Timed SoC Using TLM 2.0

In this case study, TLM 2.0 convenience sockets are used to wrap an existing ISS. This is then built into a simple SoC using additional hand-written TLM 2.0 components.

Modeling uses the TLM 2.0 *Generic Payload* with no extensions. It is independent of the specific bus architecture that will be used in the implementation.

The ISS used is from the OpenCores (www.opencores.org) project. This open source project has developed a complete 32/64-bit architecture, the OpenRISC 1000, complete with GNU compiler chain, architectural simulator and Linux port. This application note uses the OpenRISC 1000 architectural simulator, Or1ksim as the ISS for all the examples.

The model is constructed in a number of stages:

1. The basic wrapper for the Or1ksim ISS is built using TLM 2.0 convenience sockets and tested with a simple logger. In this first stage timing is ignored—this is effectively an untimed model. See Section 4 and Section 5.
2. A model UART is added as an example peripheral, demonstrating how TLM 2.0 and existing SystemC technologies can be mixed. See Section 6
3. A model of a terminal is added as a test bench for the SoC. This demonstrates how to add SystemC components which use operating system I/O without blocking the SystemC thread. See Section 7
4. Synchronous timing is added to each component, making the model loosely timed. See Section 8
5. Temporal decoupling is added to the Or1ksim ISS, UART and terminal, to improve the performance of the model. See Section 9
6. Interrupt modeling is added to the UART and the Or1ksim ISS, allowing the model to run Linux. Section 10

Simple applications, compiled with the OpenRISC 1000 tool chain are used throughout to exercise the model components. The final model is demonstrated booting a Linux 2.6 kernel.

3.1. The Example Designs

The example, a simple SoC, is based on the Or1ksim ISS for the OpenRISC 1000 architecture. The OpenRISC 1000 architecture is a conventional 32-bit DSP/RISC design, with optional caches and MMU. Or1ksim is an interpreting ISS written in C, which in its standard configuration models main memory and a number of peripherals as well as the CPU itself.

Information on obtaining and setting up the open source Or1ksim simulator and its tool chain are given in Embecosm Application Note 2. The OpenCores OpenRISC 1000 Simulator and Tool Chain: Installation Guide. [2].

For Section 4 through Section 9 the Or1ksim ISS is configured to model only the CPU and main memory, with example peripherals modeled as separate SystemC modules. For Section 10, the ISS is configured to model the data and instruction MMUs and a programmable interrupt controller (PIC). This allows the ISS to support interrupt driven peripherals and hence Linux

3.1.1. Or1ksim ISS TLM 2.0 Wrapper with Logger

In Section 4 the TLM 2.0 wrapper for the Or1ksim ISS is developed. In Section 5 the wrapped ISS is tested by connection to a simple TLM 2.0 logger module. This module records transactions sent to it on standard output as shown in Figure 2.

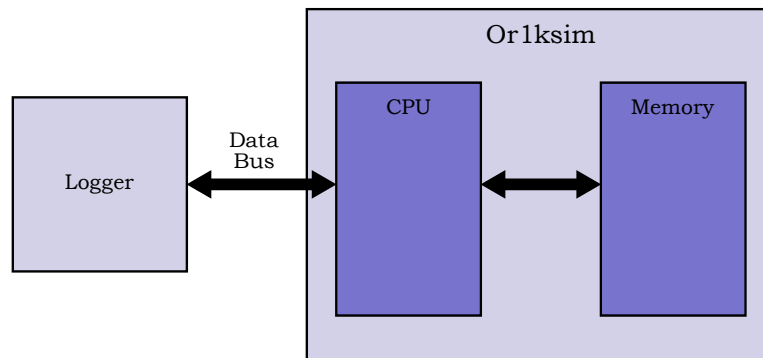

Figure 2. Testing the TLM 2.0 wrapper for the OpenRISC 1000 Or1ksim.

3.1.2. Simple SoC Design

To build a simple SoC the Or1ksim ISS CPU/memory subsystem is connected to a UART modeled in SystemC using TLM 2.0. The test bench for the system is a terminal, also modeled in SystemC using TLM 2.0 as shown in Figure 3. The model is built up in stages starting with the ISS wrapper module developed in Section 4. In sections Section 6 and Section 7 models of the UART and terminal are added to create an untimed model. Synchronous timing to create a loosely timed model is added in Section 8 and temporal decoupling to improve performance is added in Section 9. .

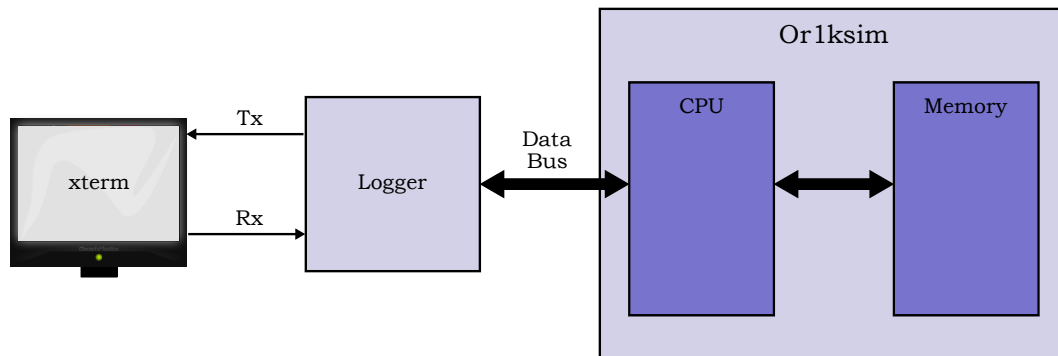

Figure 3. Simple SoC based on the OpenRISC 1000 Or1ksim.

3.1.3. SoC with Interrupt Support

To run Linux (see Section 10), the example must be extended to support interrupt driver I/O. It also needs memory management and other peripheral functions. This is provided internally to the Or1ksim ISS. This design is shown in Figure 4.

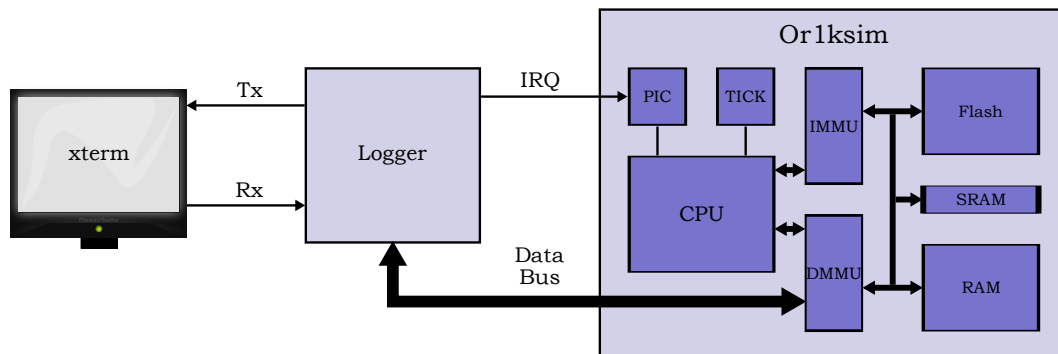

Figure 4. Simple SoC based on the OpenRISC 1000 Or1ksim with interrupts and MMU enabled.

3.2. Example Code

3.2.1. Source Code for Example Models and Programs

The code for all the SystemC models is provided in the `sysc_models` sub-directory of the code distribution. See Appendix A for details of obtaining the code.

Code for example programs which run on the models can be found in in the `sysc_models/progs_or32` sub-directory of the code distribution. Binaries are provided as well as source, but to recompile the example programs requires the OpenRISC 1000 tool chain. See Embecosm Application Note 2. The OpenCores OpenRISC 1000 Simulator and Tool Chain: Installation Guide. [2] for more information on building the OpenRISC 1000 tool chain.

3.2.2. Code Documentation

The code throughout is documented with Doxygen (see www.doxygen.org). This provides a description of the code, generated automatically from the source. The generated HTML can be found in the `doc/html` sub-directory of both the SystemC model directory and the OpenRISC 1000 program directory.

3.2.3. SystemC Model Coding Conventions

All the examples in this application note separate the definition of a class (i.e. *what* it does) in a `.h` file, from the implementation (i.e. *how* it does it) in a `.cpp` file. Class `X` is defined in file `X.h` and implemented in `X.cpp`.

The examples use the convention that classes and other type names start with an Upper Case letter (e.g. `Or1ksimSC`), variables and functions start with a lower case letter (e.g. `dataBus`) and defined or enumerated constants are all in UPPER CASE (e.g. `#define BAUD_RATE 9600`).

3.2.4. Modifying the Standard Or1ksim ISS

It is not intended that the reader should have to understand the internal workings of Or1ksim. The changes described in this application note are provided as a patch file, which can be applied to generate a fully working, modified version of the ISS. More information is provided in Appendix A.

3.2.5. Derived classes

C++ provides the hierarchical class mechanism, where derived classes inherit (some) of the functions and variables of their base class. This feature is heavily used within SystemC—for example all module classes are derived classes of the SystemC base class, `sc_module`.

The SystemC models in each section of this application note are built using derived classes of the models from previous sections.

Those functions and variables which other classes will use are declared as **public**. For SystemC modules this usually means the constructor and any SystemC ports or sockets. Occasionally there are some utility functions which are also made public (see for example `Or1ksimExt::isLittleEndian` in Section 6.3)³.

Variables and functions in classes that are not for use by other classes, but are required in derived classes are declared as **protected** (i.e. visible to derived classes).

The remaining functions and variables, which are for use only by the current class, are declared **private** (visible only to this class). This avoids any unplanned reuse by derived classes.

³ Object oriented purists prefer to expose only class functions as the **public** interface, so hiding all state implementation from external view. There is considerable merit in this, but the common SystemC convention is to expose actual ports or sockets, rather than accessor functions for those objects. This application note sticks with this practice.



Some of the functions will be reimplemented in later derived classes. Such functions are also declared **virtual**.

In summary **public** functions and variables may be used by any other class, **protected** functions and variables may be *used* only by this class and any derived classes and **private** functions and variables may be used only by this class. **virtual** functions may be *reimplemented* in derived classes.

3.2.6. Make Files

Both the **sysc_models** and **progs_or32** directory contain make files which will build the programs and Doxygen documentation, if the appropriate tools are available.

These files will need editing. In general the main **make** file, **Makefile** includes an operating system specific make file (**linux.mk** for Linux, **win32.mk** for Microsoft Windows), because of the very substantial differences in behavior between GNU **make** and Microsoft **nmake**.

In particular the SystemC model builds need to know the location of the Or1ksim binaries, libraries and include files, which should be set in the environment variable **OR1KSIM**. If left unset it will default to **/opt/or1ksim**.

4. Wrapping the ISS

The conversion of an existing ISS to a SystemC module with TLM 2.0 sockets involves several steps.

- Modify the existing ISS (in this example Or1ksim written in C) so it behaves in a manner suitable for wrapping (see Section 4.1).
- Define a SystemC module for the wrapper (see Section 4.2) and provide its implementation (see Section 4.3).
- Test the wrapper with a simple logger module attached to the TLM 2.0 socket and a suitable test application running as embedded code on the ISS (see Section 5).

4.1. Modifying the Or1ksim ISS for TLM 2.0

Most ISS need some modification before they can be incorporated into a TLM 2.0 framework. Like many ISS, Or1ksim is designed as a standalone program. The options are:

1. Keep the ISS as a standalone program, but modify it to call out to a SystemC model of the peripherals as required.
2. Modify the ISS to be a library with a set of public interfaces that can be part of a larger system.

Given the choice, option 2 is more flexible, making the ISS widely reusable in other environments. It is the approach adopted in this application note.

All the modifications required to the standard Or1ksim ISS described in this application note are provided as a **patch** file in the distribution. See Appendix A for details.

4.1.1. Converting Or1ksim to a Library

The Or1ksim `main` function first initializes the ISS, then sits in a loop executing instructions. This `main` function is replaced by a series of functions which form the interface to the library. The interface functions needed are:

- ```

int or1ksim_init(const char *config_file,
 const char *image_file,
 void *class_ptr,
 unsigned long int (*upr)(void *class_ptr,
 unsigned long int addr,
 unsigned long int mask),
 void (*upw)(void *class_ptr,
 unsigned long int addr,
 unsigned long int mask,
 unsigned long int wdata));

```

`or1ksim_init` initializes the simulator. For Or1ksim, configuration data is read from a file, which is passed as the first argument, `config_file`. The program image is passed as a second argument, `image_file`.

Or1ksim also needs to be able to call up to the SystemC model of which it is part—to read and write from the peripheral address space. These are provided as the fourth and fifth arguments, `upr` and `upw`. More explanation of the upcall mechanism can be found in Section 4.2.6.

Function calls between C and C++ can be awkward. The upcall functions form part of the SystemC module object, but are written as static functions with C linkage. To enable these functions to invoke functions in the SystemC module, they are passed a pointer

to the module class instance to use as a handle. This pointer forms the third argument, `class_ptr`.

- ```
int or1ksim_run( double duration );
```

`or1ksim_run` runs the simulator for the specified time in seconds.

4.1.2. Additional Functionality for Or1ksim

The standard Or1ksim ISS incorporates the functionality of several common peripherals. The objective of this application note is to demonstrate the ISS driving external peripherals modeled in SystemC using TLM 2.0 interfaces.

Or1ksim peripherals are configured in a textual configuration file, with a section (introduced by the keyword `section`) for each device attached. This configuration file specifies the memory mapped addresses of the peripheral. Any reads or writes to those addresses will be directed to the code of the peripheral within Or1ksim.

Or1ksim is extended with a new class of peripheral, `generic`, which specifies an external peripheral. The specification in the configuration file specifies the memory mapped address range covered and whether byte, half word or full word access are enabled. Multiple `generic` sections may be defined (for different address ranges) in the configuration file.

Code is added to Or1ksim, so that any read or write to a `generic` peripheral is redirected back to the wrapper code via the upcalls specified as arguments to `or1ksim_init` (see Section 4.1.1 and Section 4.2.6).

4.2. Or1ksim Wrapper Module Class Definition

The class definition for the Or1ksim ISS wrapper module is found in the file `Or1ksimSC.h`.

4.2.1. Included Headers

The Or1ksim SystemC wrapper module class, `Or1ksimSC`, is defined in the file `Or1ksimSC.h`. It will provide a single initiator socket, for data access, `dataBus`. No instruction accesses are planned, so modeling an external instruction bus is unnecessary.

The module includes the `tlm.h` header, which defines the core TLM 2.0 interface and the required convenience wrapper header—in this case for a simple initiator socket.

The POSIX `stdint.h` header is also included, since the definitions and code will make use of the fixed width native types defined there.

```
#include <stdint.h>

#include "tlm.h"
#include "tlm_utils/simple_initiator_socket.h"
#include "or1ksim.h"
```



Note

There is no need to include the standard `systemc` header, since this is included automatically by `tlm.h`.

4.2.2. Module Declaration

The module is declared as a standard SystemC module, i.e. as a derived class of `sc_core::sc_module`.

```
class Or1ksimSC
```



```
: public sc_core::sc_module
{
```



Note

SystemC provides a macro, so that a module can be defined by:

```
SC_MODULE( Or1ksimSC )
```

However this is equivalent (IEEE 1666-2005 section 5.2.5) to the C++ derived class declaration

```
class Or1ksimSC
: public sc_core::sc_module
{
public:
```

By using **SC_MODULE** all functions and variables will be visible to all other classes (**public**) unless there is a subsequent **protected:** or **private:** declaration.

The examples provided with SystemC and TLM 2.0 all use explicit declarations of classes derived from **sc_module** rather than the **SC_MODULE** macro. This application note uses the same approach.

4.2.3. Constructor and Destructor

Or1ksimSC needs a custom constructor, which can be passed the Or1ksim ISS configuration and image files. It will call the **or1ksim_init** function within the Or1ksim library (see Section 4.1.1) to initialize the ISS.

```
Or1ksimSC( sc_core::sc_module_name name,
const char *configFile,
const char *imageFile );
```

The default destructor is sufficient here. The module has no tidying up to do on termination.

4.2.4. Public Interface

The only public interface is the TLM 2.0 simple initiator convenience socket, **dataBus**. The TLM 2.0 convenience sockets are templated with

- the class of which any callbacks are members;
- a bus width (default **BUSWIDTH**, 32); and
- a protocol type (default the TLM 2.0 base protocol types).

For this case study, the default bus width and protocol are appropriate and need not be specified. There is no default class for the template, so **Or1ksimSC** is used. A class must be specified, even where (as in this case for a simple blocking initiator) no callbacks are actually required.

```
tlm_utils::simple_initiator_socket<Or1ksimSC> dataBus;
```

4.2.5. Threads

The module has a single thread, which executes the instructions of the ISS. The **run** function implements this:

```
void run();
```

The thread is not part of the public interface, but will be reused and reimplemented in derived classes later in the application note, so it is declared **protected** and **virtual**.

4.2.6. Upcalls

The Or1ksim ISS makes requests to read and write peripherals via the upcalls passed as arguments to `or1ksim_init` (see Section 4.1.1).

The Or1ksim ISS is implemented in C, which cannot easily call C++ class instance functions. The solution is to declare two *static* member functions which can be called from C. The call to `or1ksim_init` also received the address of the actual C++ class instance (cast to `void *`). This pointer is passed back with the upcall, so the static function can call the corresponding instance function.

A total of 4 functions are needed, one static and one instance each for read and write. The static functions use the native C/C++ types (unsigned long int), but convert to defined fixed width types for the instance functions. The native SystemC 64-bit unsigned type is used for the address (which is always 64 bits in TLM 2.0 function calls) and the POSIX 32-bit unsigned data type is used for the byte enable mask and data.

These upcall functions are not changed throughout this application note, so are declared private.

```

static unsigned long int staticReadUpcall( void *instancePtr,
                                           unsigned long int addr,
                                           unsigned long int mask );

static void staticWriteUpcall( void *instancePtr,
                               unsigned long int addr,
                               unsigned long int mask,
                               unsigned long int wdata );

uint32_t readUpcall( sc_dt::uint64 addr,
                    uint32_t mask );

void writeUpcall( sc_dt::uint64 addr,
                 uint32_t mask,
                 uint32_t wdata );

```



Caution

It might seem logical to use the SystemC limited precision types, rather than the POSIX types. However the SystemC types are *not* native C++ types, so will not cast as expected.

The transport mechanism is common to both, so provided in a utility function, `doTrans`. This function will be used and re-implemented in derived classes, so is declared **protected** and **virtual**.

4.3. Or1ksim Wrapper Module Class Implementation

The class implementation for `Or1ksimSC` is found in the file `Or1ksimSC.cpp`.

4.3.1. Headers and Macros

All the definitions required are obtained from the definition file:

```
#include "Or1ksimSC.h"
```

The implementation of a C++ class that is a SystemC module with SystemC threads (`SC_THREAD`), methods (`SC_METHOD`) or clocked threads (`SC_CTHREAD`) requires a number of definitions for that class to be set up using the `SC_HAS_PROCESS` macro.

```
SC_HAS_PROCESS( Or1ksimSC );
```



Caution

The **SC_HAS_PROCESS** macro is a common cause of confusion with new users to SystemC. It doesn't appear in the user guide and tutorial examples. The reason is that those examples use the **SC_CTOR** macro to define the constructor for the class, which provides the same definitions as the **SC_HAS_PROCESS** macro.

The **SC_CTOR** macro can only be used where the constructor's implementation is given within the class definition. As explained in Section 3.2.3, good object oriented design separates class definition from class implementation, with the constructor implemented separately from the class definition.

In cases such as this, where the constructor implementation is separate from the definition, SystemC requires that the **SC_HAS_PROCESS** macro is used before the code of any class functions. The macro is only required if the constructor uses **SC_METHOD**, **SC_THREAD** or **SC_CTHREAD** to associate a process with the module class.

4.3.2. Constructor

The constructor passes the name to the constructors of its base class (**sc_module**) and its simple initiator socket (**dataBus**), then calls the **or1ksim_init** function in the Or1ksim library to initialize the ISS.

The member function, **run** is associated with the class as a SystemC thread, using the **SC_THREAD** macro. It will be called automatically by the SystemC kernel after elaboration (i.e. SystemC initialization).

```
Or1ksimSC::Or1ksimSC ( sc_core::sc_module_name name,
                    const char          *configFile,
                    const char          *imageFile ) :
    sc_module( name ),
    dataIni( "data_initiator" )
{
    or1ksim_init( configFile, imageFile, this, staticReadUpcall,
                staticWriteUpcall );

    SC_THREAD( run );           // Thread to run the ISS
}                               /* Or1ksimSC() */
```

4.3.3. Thread

The main thread, **run**, invokes the Or1ksim ISS to run for ever (by passing a negative time argument). The ISS will use the upcalls (see Section 4.2.6) to request reads from and writes to the peripheral address space.

The thread is called automatically when the SystemC kernel has completed elaboration (i.e. is initialized).

```
void
Or1ksimSC::run()
{
    scLastUpTime = sc_core::sc_time_stamp();
    or1kLastUpTime = or1ksim_time();

    (void)or1ksim_run( -1.0 );
}                               // Or1ksimSC()
```

4.3.4. Upcalls

Two functions are declared as static member functions to implement the upcalls from the Or1ksim library (see Section 4.2.6 for an explanation of why these functions are static).

The static functions receive the pointer to the **Or1ksimSC** instance which originally started the Or1ksim ISS (provided as an argument to **or1ksim_init** described in Section 4.3.3).

This allows each static function to call the instance function which implements the upcall, as shown here with **staticReadUpcall**:

```
unsigned long int
Or1ksimSC::staticReadUpcall( void          *instancePtr,
                             unsigned long int  addr,
                             unsigned long int  mask )
{
    Or1ksimSC *classPtr = (Or1ksimSC *)instancePtr;

    return (unsigned long int)classPtr->readUpcall( (sc_dt::uint64)addr,
                                                    (uint32_t)mask );
} // staticReadUpcall()
```

The address is cast to the SystemC native 64-bit type, which is always used in TLM 2.0 for addresses. The mask and result (and write data for **staticWriteUpcall** are cast to the POSIX **uint32_t** fixed length type to avoid any ambiguity over size⁴.



Caution

It might be thought that providing a direct upcall to the C++ upcall functions of the class would be more efficient, using the C++ member reference operator (**::***). However the linkage to a member is much more complex (to cope with inheritance and overloading). Lack of standardization in the C++ Application Binary Interface (ABI) means that such linkage between C and C++ will not necessarily work.

Linkage to static functions is much simpler and usually works between C and C++. So the approach used here is more reliable.

The upcalls from the ISS generate the transactional activity. These functions set up the payload, execute the transaction (i.e. exchange the payload and result with the target) and return the result to the ISS.

The example here is coded in a very simple fashion, in the knowledge that the requests to read are always four bytes long (the OpenRISC 1000 has a simple 32 bit bus), possibly with some bytes masked out for byte and half-word reads. This matches the default **BUSWIDTH** of the simple initiator socket.

Both payload and data are declared as local (automatic) variables, i.e. on the stack. This is fine with a blocking transport function, since they will remain valid for the duration of the transaction. The data and mask are both encoded in the four bytes of a POSIX **uint32_t**.



Caution

Using local variables in this way would *not* be appropriate with a non-blocking socket, since the initiator function could return before the result of the transaction is received back from the target.

TLM 2.0 requires that the payload, data and mask fields all remain valid for the duration of the complete transaction, so in this case the variables would need to be allocated and deleted from the heap.

⁴ While **unsigned long int** is almost always 32 bits long, it is not guaranteed to be so.

4.3.5. Blocking Transport

Once the payload fields are set up, the **doTrans** function (which is used for both read and write) is called to transport the payload to the target and return the result.

The transport function requires a time to be supplied, even when timing is not being used (as in this case). This must be time variable, not a constant, since the target can update the value. A dummy variable is declared with zero time and passed to the blocking transport function of the socket with the payload.

```
sc_core::sc_time dummyDelay = sc_core::SC_ZERO_TIME;  
dataBus->b_transport( trans, dummyDelay );
```

This implementation is sufficient for modeling just the Or1ksim ISS in SystemC. However at no time does the thread execute a SystemC **wait** call. In the absence of any such yield, no other thread would be able to execute. This will be remedied in Section 6 when other threads are added to model peripherals.

5. Testing the Or1ksim ISS TLM 2.0 Wrapper

The test configuration was shown earlier in Figure 2. For this a simple logger is needed, which must implement a TLM 2.0 simple target socket.

In addition, a simple embedded application is needed to run on the Or1ksim ISS, which will make reads and writes to peripheral address space, which can be detected by the logger.

All the behavior is in the callback function—there are no SystemC threads. This means the logger will be suitable for testing the **Or1ksimSC** wrapper module, even though its thread never yields (see Section 4.3.5).

5.1. Definition of the TLM 2.0 Logger Module

5.1.1. Include Files

The logger is based on the TLM 2.0 convenience simple target socket, so needs the appropriate header, in addition to the standard TLM 2.0 header:

```
#include "tlm.h"
#include "tlm_utils/simple_target_socket.h"
```

5.1.2. Module Declaration and Constructor

The class is a standard SystemC module:

```
class LoggerSC
: public sc_core::sc_module
```

A custom constructor is needed, which will be used to register the callback function for the simple target convenience socket blocking transport.

```
LoggerSC( sc_core::sc_module_name name );
```

5.1.3. Public Interface

The public interface is the single simple target convenience socket.

```
tlm_utils::simple_target_socket<LoggerSC> loggerPort;
```

5.1.4. Blocking Transport

Blocking transport is via a callback function:

```
void loggerReadWrite( tlm::tlm_generic_payload &payload,
                    sc_core::sc_time          &delay );
```

All the behavior of the module is captured in this callback function. There are no SystemC threads required.

5.2. Implementation of the TLM 2.0 Logger Module

5.2.1. Included Headers

The logger will be doing a certain amount of stream IO, so includes the C++ headers that define stream manipulation functions. The POSIX standard integer types are also included.

```
#include <iostream>
#include <iomanip>
#include <stdint.h>

#include "LoggerSC.h"
```

5.2.2. Constructor

The constructor passes its argument (the module) name to the base class **sc_module** constructor. The body of the function then registers the **loggerReadWrite** function as the callback for blocking transport to this convenience socket. This means that any initiator which requests

blocking transport (by calling the initiator socket's `b_transport` function) will invoke this callback function in the target.

```

LoggerSC::LoggerSC( sc_core::sc_module_name name ) :
    sc_module( name )
{
    loggerPort.register_b_transport( this, &LoggerSC::loggerReadWrite );
}
// Or1ksimSC()

```

5.2.3. Blocking Transport Callback

The callback function, `loggerReadWrite` records the key information regarding any transaction it receives. The payload is a TLM 2.0 Generic Payload, with appropriate access functions. In this simple implementation, a length of 4 bytes is assumed for the data in the payload.

To get at the data and byte enable mask, the pointers to `unsigned char` are cast to pointers to the POSIX fixed width type, `uint32_t`, as was used with `Or1ksimSC`. Endianism issues due to the byte pointers not being word aligned are not an issue, because the `Or1ksimSC` module also declared them as `uint32_t`.

```

void
LoggerSC::loggerReadWrite( tlm::tlm_generic_payload &payload,
                          sc_core::sc_time          &delay )
{
    // Break out the address, mask and data pointer.

    tlm::tlm_command   comm    = payload.get_command();
    sc_dt::uint64      addr    = payload.get_address();
    unsigned char      *maskPtr = payload.get_byte_enable_ptr();
    unsigned char      *dataPtr = payload.get_data_ptr();

    // Record the payload fields (data only if it's a write)

    const char *commStr;

    switch( comm ) {
    case tlm::TLM_READ_COMMAND:   commStr = "Read";   break;
    case tlm::TLM_WRITE_COMMAND:  commStr = "Write";  break;
    case tlm::TLM_IGNORE_COMMAND: commStr = "Ignore"; break;
    }

    std::cout << "Logging" << std::endl;
    std::cout << "  Command:      " << commStr << std::endl;
    std::cout << "  Address:      0x" << std::setw( 8 ) << std::setfill( '0' )
                <<std::hex << (uint64_t)addr << std::endl;
    std::cout << "  Byte enables: 0x" << std::setw( 8 ) << std::setfill( '0' )
                <<std::hex << *((uint32_t *)maskPtr) << std::endl;

    if( tlm::TLM_WRITE_COMMAND == comm ) {
        std::cout << "  Data:          0x" << std::setw( 8 ) << std::setfill( '0' )
                    <<std::hex << *((uint32_t *)dataPtr) << std::endl;
    }

    std::cout << std::endl;
}

```

```
payload.set_response_status( tlm::TLM_OK_RESPONSE ); // Always OK
} // loggerReadWrite()
```

5.3. The Model Main Program

The logger module and the Or1ksim wrapper module must be connected in the main program (`sc_main` since this is SystemC), and the simulation invoked.

5.3.1. Included Headers

The program includes the main TLM 2.0 header and the header of the two modules which will be used:

```
#include "tlm.h"
#include "Or1ksimSC.h"
#include "LoggerSC.h"
```

5.3.2. Argument Processing

The program takes two arguments, an Or1ksim configuration file (described further in Section 5.5) and a binary image to execute on the Or1ksim ISS (see Section 5.4).

```
int sc_main( int argc,
             char *argv[] )
{
    if( argc != 3 ) {
        fprintf( stderr, "Usage: TestSC <config_file> <image_file>\n" );
        exit( 1 );
    }
}
```

5.3.3. Module Instantiation

Instances of the Or1ksim ISS and the logger are created, the ISS being passed the two program arguments for its initialization.

```
Or1ksimSC iss( "or1ksim", argv[1], argv[2] );
LoggerSC logger( "logger" );
```

5.3.4. Connecting the Modules

The target socket of the logger (`loggerPort`) is connected by passing it as argument to the initiator socket of the ISS (`dataBus`). The C++ function application operator, `()`, is overloaded for initiator sockets to provide this binding function.

```
iss.dataBus( logger.loggerPort );
```

5.3.5. Model Execution

Once the model is instantiated, simulation is invoked to run forever.

```
sc_core::sc_start();
```

5.4. Test Program to Run on the Or1ksim

The test program in `logger_test.c` defines a memory mapped volatile data structure and then writes to and reads from each element of that structure. Compilation of this program requires the OpenRISC 1000 GNU tool chain (see Embecosm Application Note 2. The OpenCores OpenRISC 1000 Simulator and Tool Chain: Installation Guide. [2] for details of installing this).

5.4.1. The Utility Functions

The test program uses some simple utility functions which can write characters (`simputc`), string (`simputs`) and hexadecimal numbers (`simputh`). Its header is included:

```
#include "utils.h"
```

The utilities' implementation can be found in `utils.c`.

5.4.2. Memory Mapped Data Structure

The memory mapped address is defined in the configuration of Or1ksim (see Section 5.5) to be 0x90000000. This is set as a defined constant in the test program.

```
#define BASEADDR 0x90000000
```

The memory mapped structure consists of a byte, half word (16 bits) and full word (32 bits), all declared as **volatile** within the **struct**. These are all declared with the C types, which for the OpenRISC 1000 tool chain are known to correspond to these sizes.

```
struct testdev
{
    volatile unsigned char    byte;
    volatile unsigned short int halfword;
    volatile unsigned long int fullword;
};
```

The main program declares a pointer to this **struct** at the **BASEADDR**, along with 3 variables to hold the results of the various sized results when reading.

```
main()
{
    struct testdev *dev = (struct testdev *)BASEADDR;

    unsigned char    byteRes;
    unsigned short int halfwordRes;
    unsigned long int fullwordRes;
```

5.4.3. Checking Write Access

The details of each write are logged and the value then written. (In the absence of a **printf**, the logging is necessarily cumbersome).

```
simputs( "Writing byte 0xa5 to address 0x" );
simputh( (unsigned long int)&(dev->byte) );
simputs( "\n" );
dev->byte = 0xa5;

simputs( "Writing half word 0xbeef to address 0x" );
simputh( (unsigned long int)&(dev->halfword) );
simputs( "\n" );
dev->halfword = 0xbeef;

simputs( "Writing full word 0xdeadbeef to address 0x" );
simputh( (unsigned long int)&(dev->fullword) );
simputs( "\n" );
dev->fullword = 0xdeadbeef;
```

5.4.4. Checking Read Access

The values are then read back. No results are expected (the logger does not set any values), but this should check the process behaves as expected.

```
byteRes = dev->byte;
simputs( "Read 0x" );
simputh( byteRes );
simputs( " from address 0x" );
simputh( (unsigned long int)&(dev->byte) );
simputs( "\n" );
```

```

halfwordRes = dev->halfword;
simputs( "Read 0x" );
simputh( halfwordRes );
simputs( " from address 0x" );
simputh( (unsigned long int)&(dev->halfword)) );
simputs( "\n" );

fullwordRes = dev->fullword;
simputs( "Read 0x" );
simputh( fullwordRes );
simputs( " from address 0x" );
simputh( (unsigned long int)&(dev->fullword)) );
simputs( "\n" );

```

At the end of the program, the utility `simexit` is used. This not only terminates the program, but will also exit the simulation.

5.4.5. Program Compilation

The program is compiled with the utility functions (in `utils.c`) and a small boot loader (in `start.s`) which defines a `_start` function which invokes `main`. The linker arguments are chosen to make the program load from start of memory, with the `_start` function sitting at the OpenRISC 1000 reset vector (0x100).

5.5. Running the Test

5.5.1. Compiling the SystemC Model

The SystemC modules are each compiled with access to the Or1ksim, SystemC and TLM 2.0 header directories. It is also essential that `SC_INCLUDE_DYNAMIC_PROCESSES` is defined when using TLM 2.0:

```

g++ -ggdb -DSC_INCLUDE_DYNAMIC_PROCESSES -I$OR1KSIM_HOME/include \
-I$SYSTEMC_HOME/include -I$TLM_HOME/include/tlm -c TestSC.cpp
g++ -ggdb -DSC_INCLUDE_DYNAMIC_PROCESSES -I$OR1KSIM_HOME/include \
-I$SYSTEMC_HOME/include -I$TLM_HOME/include/tlm -c Or1ksimSC.cpp
g++ -ggdb -DSC_INCLUDE_DYNAMIC_PROCESSES -I$OR1KSIM_HOME/include \
-I$SYSTEMC_HOME/include -I$TLM_HOME/include/tlm -c LoggerSC.cpp

```

The final linking must include the SystemC library, and since the Or1ksim library includes some shared objects, linker directions to find those shared objects (`-Wl,--rpath,$OR1KSIM_HOME`).

```

g++ -ggdb -DSC_INCLUDE_DYNAMIC_PROCESSES TestSC.o Or1ksimSC.o LoggerSC.o \
-Wl,--rpath,$OR1KSIM_HOME/lib -L$OR1KSIM_HOME/lib \
-L$SYSTEMC_HOME/lib-linux -lsim -lsystemc -o TestSC

```

5.5.2. Configuring the OpenRISC 1000 Or1ksim ISS

The Or1ksim ISS is configured using a textual configuration file, described in more detail in Embecosm Application Note 2. The OpenCores OpenRISC 1000 Simulator and Tool Chain: Installation Guide. [2]. For the modified Or1ksim ISS, `generic` peripherals can be added (see Section 4.1.2), which will cause code to call out via the upcall mechanism to the Or1ksim SystemC wrapper module (see Section 4.2.6).

The Or1ksim configuration file for this example is in `simple.cfg`. It disables all the standard peripherals and specifies one block of memory from address 0x0. It adds a `generic` peripheral allowing byte, half word and full word access to addresses mapped from 0x90000000 to 0x90000007, with the following configuration file entry

```

section generic

```

```

enabled      =      1
baseaddr    = 0x90000000
size        =      0x8
name        = "External UART"
byte_enabled =      1
hw_enabled  =      1
word_enabled =      1
end

```

5.5.3. Running the Compiled Model

The compiled program can be executed by passing in as arguments the Or1ksim configuration file and the OpenRISC 1000 binary. The result is shown in Figure 5.

```

$ ./TestSC ../simple.cfg progs_or32/logger_test

      SystemC 2.2.0 --- May 16 2008 10:30:46
      Copyright (c) 1996-2006 by all Contributors
      ALL RIGHTS RESERVED
Reading script file from '../simple.cfg'...

... <Or1ksim initialization messages>

Writing byte 0xa5 to address 0x09000000
Logging
Command:      Write
Address:      0x90000000
Byte enables: 0x000000ff
Data:        0x000000a5
Delay:       0.000000000s

Writing half word 0xbeef to address 0x09000002
Logging
Command:      Write
Address:      0x90000000
Byte enables: 0xffff0000
Data:        0xbeef0000
Delay:       0.000000000s

... <More test program output>

Logging
Command:      Read
Address:      0x90000004
Byte enables: 0xffffffff
Delay:       0.000000000s

Read full word 0x0 from address 0x09000004
exit(0)
@reset : cycles 0, insn #0
@exit  : cycles 26921, insn #13854
diff   : cycles 26921, insn #13854
$

```

Figure 5. Output from the logger test of the Or1ksim wrapper module.

Each access from the application program generates the expected transactional access. All accesses are 32 bits wide, but for byte and half-word access the relevant bytes are masked off.



Note

The Or1ksim ISS can be configured to model big-endian architectures. The TLM 2.0 payloads are always packed with data using the endianism of the model.

If the exercise were repeated with a big-endian version of Or1ksim the addresses of the access would be unchanged (they are word aligned), but the byte enable masks for the byte and half word accesses would be inverted.

6. Modeling Peripherals

This example uses a single peripheral, a UART. The UART model is based on National Semiconductor 16450 design.

6.1. Details of the 16450 UART

The 16450 UART is a very long established industry component. Data written a byte at a time into the transmit buffer is converted to serial pulses on the output (Tx) pin. Serial pulses on the input (Rx) pin are recognized and converted to byte values, which can be read from the receive buffer. Typically Rx and Tx are connected to a terminal and keyboard which can generate and recognize the pulses of data. The UART can also generate additional signals for terminals and keyboards to provide physical flow control, but that is beyond the scope of this model. The key interfaces are shown in Figure 6.

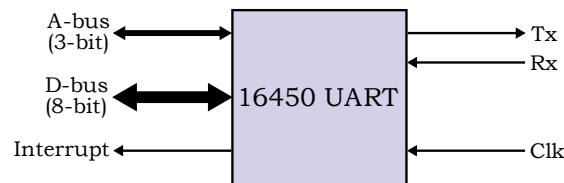

Figure 6. 16450 UART: Key interfaces.

The 16450 UART specifies a set of registers which control the UART behavior. On the Tx/Rx side, this includes setting the board rate and the pattern of stop, start and data bits. On the CPU side this includes configuring interrupt behavior (if any) and setting flags to show the status of transmit and receive buffers. The registers are shown in Table 1.

Address	Register	R/W	Description
0	RXBUF	R	When the DLAB bit is 0 (see register LCR , this is the buffer for read data.
	TXBUF	W	When the DLAB bit is 0 (see register LCR , this is the buffer for data to be written.
	DLL	R/W	When the DLAB bit is 1 (see register LCR , this is the low byte of the divisor latch (which controls UART performance)
1	IER	R/W	The interrupt enable register. The lower 4 bits control which events generate an interrupt.
	DLH	R/W	When the DLAB bit is 1 (see register LCR , this is the high byte of the divisor latch (which controls UART performance)
2	IIR	R	Interrupt identification register. Bit 0 indicates if an interrupt is pending, bits 1-2 the reason for the interrupt.
3	LCR	R/W	Line control register. Various bits controlling the behavior of the UART. Of these, DLAB , bit 7, the divisor latch access bit is important, because it controls the behavior of registers 0 (RXBUF/TXBUF/DLL) and 1 (IER/DLH).
4	MCR	W	Modem control register. Bits 0-4 control the behavior of the modem.
5	LSR	R	Line status register. Bits 0-6 report the status of the UART. Of these, DR , bit 0, receiver data ready is important, indicating there is valid data in RXBUF .

Address	Register	R/W	Description
6	MSR	R	Modem Status Register. Bits reporting the state of the modem.
7	SCR	R/W	Scratch register. Not used by the UART, but may be used by the application to store an 8-bit value.

Table 1. NS 16450 UART Registers

6.2. UART Module Design

A transaction level model cannot show all the intricacies of a UART—the whole point is to simplify and remove detail.

The TLM should allow the CPU to read and write registers, a terminal to send and receive characters and should generate interrupts as appropriate. While all writable registers can be written and all readable registers read, only those registers and bits of registers which are relevant to this level of modeling will have any impact on behavior.

6.2.1. UART Model Interfaces

A TLM 2.0 socket is the natural model for the bus interface to the CPU. However the interface to the terminal is much simpler. Standard SystemC buffers (**sc_buffer**) will be suitable, one for the Rx direction and one for Tx. The buffer is implemented for the Rx direction and a port to a buffer for the Tx direction. The terminal (see Section 7) will offer the complementary arrangement.



Note

A SystemC buffer (**sc_buffer**) is used rather than a (**sc_signal**), since it must report all writes to the buffer, rather than just changes to the value (as would be the case with a signal). At this level of modeling it is quite possible that two identical bytes would follow each other.

The interrupt is not modeled as an interface at this stage, so the UART will only be suitable for polled use. An interrupt interface is added in Section 10.

6.2.2. UART Model Registers

The divisor latch affects the baud rate, which will affect timing of transfers. This will be covered in a later section (see Section 8), but is not needed for the current untimed model. The value can be written and read, but does not affect behavior.

All interrupts are modeled (see Section 6.2.3), so all bits in the interrupt enable and interrupt control register are modeled.

The modem control and status registers are only modeled to the extent of supporting modem loopback. This is used by some software to determine the nature of the modem (for example in the standard Linux serial line driver).

The line control register sets details of the bit transfers. In a later section (see Section 8), this will affect the timing of transfers, but it is not relevant to the current untimed model.

In the Line Status Register, the **Data Ready** and **Transmitter Holding Empty/Transmitter Empty** bits are the only ones modeled. The model does not distinguish a separate buffer and holding transmit register, so the last two of these will move in step in the model.

6.2.3. UART Model Interrupts

All interrupts are modeled, although there is no way to cause a receiver line status interrupt. The modem status interrupt can only be generated when modem loopback is in operation.

6.3. Extending the Or1ksimSC Wrapper Module

For a larger system, the Or1ksim wrapper module described in Section 4 must be extended. A public function is required for peripheral models to establish the CPU endianism.

The function must be added to the underlying Or1ksim library and then a wrapper function added to the **Or1ksimSC** wrapper module.

In Section 4.3.5 it was noted that the absence of any call to **wait** meant the Or1ksim ISS could be the only thread in the model. The **doTrans** function must be extended to yield after each transaction to allow other threads to run.

These extensions are achieved by defining a new class, **Or1ksimExtSC** derived from the existing **Or1ksimSC** class. It inherits all the functionality of the existing class, re-implements that of the transport function, **doTrans** and adds an additional public interface function, **isLittleEndian**.

6.3.1. Adding an Endianism Test Function to the Or1ksim Library

The additional function is straightforward, since endianism is a compile time constant in the Or1ksim ISS.

- ```
int or1ksim_is_le();
```

**or1ksim\_is\_le** returns 1 if Or1ksim is modeling a little endian architecture, 0 otherwise. It is needed to ensure the payload is packed with the correct byte ordering.

#### 6.3.2. Extended Or1ksim Wrapper Module Class Definition

The new class, **Or1ksimExtSC** is derived from **Or1ksimSC**, so the definition file includes its header. The module class can then inherit from that class.

```
#include "Or1ksimSC.h"

class Or1ksimExtSC
: public Or1ksimSC
{
```

A custom constructor must be defined. Custom constructors do not inherit, so a new custom constructor is defined just to pass the arguments on to the base class.

```
Or1ksimExtSC(sc_core::sc_module_name name,
 const char *configFile,
 const char *imageFile);
```

A new public function to report the endianism of the underlying CPU model is defined

```
bool isLittleEndian();
```

The **doTrans** is reimplemented here, to allow the thread to yield. The function remains protected and virtual, since it will be redefined again later in this application note.

```
virtual void doTrans(tlm::tlm_generic_payload &trans);
```

#### 6.3.3. Extended Or1ksim Wrapper Module Class Implementation

The constructor just passes its arguments to its base class

```
Or1ksimExtSC::Or1ksimExtSC (sc_core::sc_module_name name,
 const char *configFile,
 const char *imageFile) :
Or1ksimSC(name, configFile, imageFile)
```

```
{
} // Or1ksimExtSC()
```

`isLittleEndian` is a simple wrapper for the underlying Or1ksim ISS library function<sup>5</sup>.

```
bool
Or1ksimExtSC::isLittleEndian()
{
 return (1 == or1ksim_is_le());
} // or1ksimIsLe()
```

The majority of the code for `doTrans` is unchanged from its implementation in `Or1ksimSC`. The addition is a `wait` for zero time immediately after the transaction has completed. This allows the SystemC thread to yield, so that any other threads that are ready can take a turn.

```
wait(sc_core::SC_ZERO_TIME);
```



### Caution

The call to `wait` is essential. SystemC is not preemptive. Other threads are only considered for execution when the currently executing thread yields. If the code were to return here, control would pass back to the underlying Or1ksim ISS until its next upcall, with no opportunity for another SystemC thread to execute.

The implementation currently is untimed, so a zero delay wait is perfectly acceptable. That just gives all the other untimed threads a turn at execution.

The logger described in Section 5 worked without this call to `wait`, because it had no thread—all its functionality was in the blocking transaction callback function.

## 6.4. UART: Module Class Definition

The UART module class, `UartSC` is defined in `UartSC.h`. It uses the TLM 2.0 simple target convenience socket (described earlier in Section 5).

### 6.4.1. Headers and Constant Definitions

The header files for TLM 2.0 and the simple target convenience socket are included.

```
#include "tlm.h"
#include "tlm_utils/simple_target_socket.h"
```

Convenience constants for the address mask, named register offsets and bit fields are then defined. The address mask is needed, since in this simple SoC model there is no arbiter/decoder to strip out the higher order bits from the address before the transaction is sent to the UART.

```
#define UART_ADDR_MASK 7 // Mask for addresses (3 bit bus)
```

Named constants are defined giving the address offset of each register of the UART

```
#define UART_BUF 0 // R/W: Rx/Tx buffer, DLAB=0
#define UART_IER 1 // R/W: Interrupt Enable Register, DLAB=0
#define UART_IIR 2 // R: Interrupt ID Register
#define UART_LCR 3 // R/W: Line Control Register
#define UART_MCR 4 // W: Modem Control Register
#define UART_LSR 5 // R: Line Status Register
```

<sup>5</sup> A technicality is that the Or1ksim library function, `is_little_endian` returns an `int`, since C does not have a `bool` type. A C++ compiler would automatically convert one to the other, but making the comparison explicit is good for clarity. The same code will be generated, so there is no loss of performance.



```
#define UART_MSR 6 // R: Modem Status Register
#define UART_SCR 7 // R/W: Scratch Register
```

Bit masks are declared for each of the bits and bit fields of interest in the UART. For example the interrupt identification register needs a mask for the pending bit a mask for the two bits representing the highest priority interrupt and a mask for each possible interrupt.

```
#define UART_IIR_IPEND 0x01 // Interrupt pending (active low)

#define UART_IIR_MASK 0x06 // the IIR status bits
#define UART_IIR_RLS 0x06 // Receiver line status
#define UART_IIR_RDA 0x04 // Receiver data available
#define UART_IIR_THRE 0x02 // Transmitter holding reg empty
#define UART_IIR_MOD 0x00 // Modem status
```

### 6.4.2. Class Declaration and Constructor

The main class is a standard SystemC module class derived from `sc_core::sc_module`.

```
class UartSC
: public sc_core::sc_module
{
```

The module has a customized constructor, specifying an input clock rate (which in the SoC example will be the SoC clock rate), and a flag to indicate the endianism of the model.

```
UartSC(sc_core::sc_module_name name,
 unsigned long int _clockRate,
 bool _isLittleEndian);
```

### 6.4.3. Public Interface

The interfaces to the UART model are:

- The simple target convenience socket, **bus**, representing the bus from the CPU;
- A byte wide SystemC buffer (`sc_buffer<unsigned char>`) for the Rx pin; and
- A byte wide SystemC output port (`sc_out<unsigned char>`) for the Tx pin.

No external port is provided for the interrupt at this stage. That will be added in Section 10

### 6.4.4. SystemC Processes

A SystemC thread is provided **busThread** to handle transactions arriving on the bus. A SystemC method, statically sensitive to writes to the Rx buffer is used to handle bytes arriving in the Rx buffer.



#### Note

Unlike threads, SystemC methods may not yield by calling **wait**. A SystemC method is started when one of its static sensitivities is triggered and runs to completion. It is suitable here, where it runs when a character is received, copying that character to the UART **RXBUF** register and then exiting.

it is worth using SystemC methods whenever possible, because they can potentially be implemented more efficiently than threads.

### 6.4.5. Blocking Transport Callback

The blocking transport callback function is **busReadWrite**. This in turn calls for two separate functions which implement read specific (**busRead**) and write specific (**busWrite**) behavior.

### 6.4.6. Utility Functions

A utility function, `modemLoopback` determines the state of registers and generates an interrupt in the event of modem loopback being requested (a bit in the modem control register). It is used by the `busRead` and `busWrite` functions.

Three utility functions are provided to handle interrupts. `setIntrFlags` sets the interrupt indication register according to which interrupts are currently pending. `genIntr` generates an interrupt and `clrIntr` clears an interrupt. In this implementation these functions ensure all register flags are set correctly but do not drive an external interrupt signal.

A set of convenience utilities are provided to set and clear flags in registers (`set` and `clear`) and to test the state of a flag bit in a register (`isSet` and `isClear`).

### 6.4.7. UART State

`struct regs` is used to hold the value of each register. There are ten of these, since register 0 is really two registers, depending on whether it is being read (`rbr`) or written (`thr`) and the divisor latch is really an extra 16 bit register.

```

struct {
 unsigned char rbr; // R: Rx buffer,
 unsigned char thr; // R: Tx hold reg,
 unsigned char ier; // R/W: Interrupt Enable Register
 unsigned char iir; // R: Interrupt ID Register
 unsigned char lcr; // R/W: Line Control Register
 unsigned char mcr; // W: Modem Control Register
 unsigned char lsr; // R: Line Status Register
 unsigned char msr; // R: Modem Status Register
 unsigned char scr; // R/W: Scratch Register
 unsigned short int dl; // R/W: Divisor Latch
} regs;

```

An additional register, `intrPending`, holds flags (corresponding the interrupt enable register bits) indicating which interrupts are currently pending. A flag initialized at construction records the model endianism, `isLittleEndian`.

### 6.4.8. Notifying the Bus Thread of Transaction Activity

A function is needed for the TLM 2.0 callback function, `busReadWrite` to notify the thread handling data being sent for transmission (`busThread`). This is achieved with a SystemC event:

```
sc_core::sc_event txReceived;
```

The callback function notifies on this event, to trigger behavior in the `busThread`.

## 6.5. UART Module Class Implementation

### 6.5.1. UART Constructor

Implementation of the constructor is preceded, like `Or1ksimSC`, by the SystemC macro

```
SC_HAS_PROCESS(UartSC);
```

The constructor calls the base class (`sc_module`) constructor to set the module name, saves the endianism flag in its internal state variable and clears the interrupt pending flags. The thread to handle bus I/O is associated with this module.

```
SC_THREAD(busThread);
```

The method handling data on the Rx buffer is associated with this module with static sensitivity to writes to that buffer. It is not initialized.

```
SC_METHOD(rxMethod);
sensitive << rx;
dont_initialize();
```

The blocking transport callback is registered for the **bus** socket, in the same manner as was used for the logger, **LoggerSC**.

```
bus.register_b_transport(this, &UartSC::busReadWrite);
```

Finally the registers (**regs**) are cleared.

### 6.5.2. UART Threads

**busThread** sits in a perpetual loop. It first marks the transmit buffer as empty (on reset the flags are cleared, so the buffer will appear full).



#### Note

The 16450 UART describes two flags for transmit buffer status, one to indicate that the transmit holding register is empty and a second to indicate that the internal transmit buffer register is empty.

For simplicity, this model does not model a separate internal register (effectively a one byte FIFO), so both flags are set and cleared together.

If the transmit buffer empty interrupt is enabled, the thread generates an interrupt to indicate that the buffer is empty.

The thread then waits until it is notified via the SystemC event **txReceived** that a byte is in the buffer to be sent. This event will be triggered by the **busWrite** callback when a value is written into the transmit holding register.

The second thread, **rxThread** sits in a perpetual loop, waiting for characters to be received on the Rx buffer. The character is read into the read buffer register and the line status data ready flag is set to indicate availability.

If the receive data interrupt is enabled, an interrupt is asserted to indicate data availability.

### 6.5.3. UART Blocking Transport Callback

The registered callback function is **busReadWrite**, which breaks out the address, byte enable mask pointer and data pointer. A **switch** statement on the mask is used to determine the offset of the actual byte requested and hence the exact byte address, allowing for the endianism of the model. This also provides a check that only a single byte is being requested.

```
switch(*((uint32_t *)maskPtr)) {
case 0x000000ff: offset = isLittleEndian ? 0 : 3; break;
case 0x0000ff00: offset = isLittleEndian ? 1 : 2; break;
case 0x00ff0000: offset = isLittleEndian ? 2 : 1; break;
case 0xff000000: offset = isLittleEndian ? 3 : 0; break;

default: // Invalid request

 payload.set_response_status(tlm::TLM_GENERIC_ERROR_RESPONSE);
 return;
}
```

In a perfect world, the router/arbiter function would have masked the address to the range handled by the UART. However for this simple model, the full address is received, so masking with `UART_ADDR_MASK` is carried out here, to give the address of the UART register being read.

Separate functions, `busRead` and `busWrite` are used to implement the register specific behavior, selected as appropriate based on the payload command field.

Single byte reads and writes always succeed, so the response is set to `t1m:TLM_OK_RESPONSE` in all cases.

#### 6.5.4. UART Read Behavior

Read behavior is handled by `busRead`. A switch on the address is used to identify the result to be returned, usually just the value in the register if it is readable. The interesting cases are:

- If the `DLAB` bit is set in the line control register, then reads to the first two registers (read buffer and interrupt enable) yield instead the low and high bytes of the divisor latch.
- Reading the read buffer (when `DLAB=0`) yields the byte just read, if flag `DR` is set in the line status register. The act of reading causes the `DR` flag and the read buffer full interrupt to be cleared. If no interrupts remain pending then the interrupt pending flag is cleared.
- Reading the interrupt indicator register clears the transmit buffer empty interrupt if it was pending. If no interrupts remain pending, then the interrupt pending flag is cleared.
- Reading the line status register clears any error indications and the receive line status interrupt if it was pending, although the model has no way of setting any of these indications. If no interrupts remain pending, then the interrupt pending flag is cleared.
- Reading the modem status register clears all flags and the modem status interrupt if it was pending. However the modem loopback indication may still be in operation and if so the bits and interrupts are set to indicate the state of the loopback by a call to `modemLoopback`. If no interrupts remain pending, then the interrupt pending flag is cleared.

#### 6.5.5. UART Write Behavior

Write behavior is handled by `busWrite`. A switch on the address is used to identify the action required. Usually the register is just written (if writable). The interesting cases are:

- If the `DLAB` bit is set in the line control register, then writes to the first two registers (read buffer and interrupt enable) update the low and high bytes of the divisor latch respectively.
- Writing the transmit hold register (when `DLAB=0`) triggers a new transfer. The flags are set to indicate data is in the register, the transmit buffer empty interrupt is cleared, and the bus thread (`busThread`) notified via the SystemC event `txReceived`. If no interrupts remain pending, then the interrupt pending flag is cleared.
- If the modem loopback bit is set by a write to the modem control register, then the modem status bits are set appropriately by a call to `modemLoopback`. If enabled a modem status interrupt may be generated.

#### 6.5.6. UART Utility Functions

`setIntrFlags` determines the setting of the interrupt identification register according to which interrupts are currently pending (in `intrPending`).

`genIntr` generates an interrupt by marking the corresponding interrupt as pending if the interrupt is enabled and setting the interrupt identification register flags appropriately. In this

implementation, no external signal is generated (see Section 10 for details of generating an interrupt signal).

**clrIntr** clears the interrupt pending flag (no need to check if the interrupt is enabled in this case) and sets the appropriate interrupt identification register flags. Again there is no external generated in this implementation.

A set of functions are provided to set, clear and test bits in registers. Using these makes the code much more readable<sup>6</sup>.

---

<sup>6</sup> Many programmers use **#defined** macros for functions such as these. However such macros have no encapsulation (they can be used by anyone including the header) and have a nasty habit of clashing with other peoples macros. By using functions, the functions can be made private to the **UartSC** class alone. The functions are declared in line, and a modern C++ compiler will generate code as efficiently as if they had been **#defined** as macros. Indeed the added type information gives the potential for greater optimization.

## 7. Adding a Terminal as a Test Bench

The Or1ksim ISS described in Section 4 and the UART described in described in Section 6 can be put together as a minimal SoC. However a test bench is needed to exercise that SoC

The usual way of exercising a SoC with a UART is to connect a terminal to the UART. This section describes a suitable SystemC model of a terminal and how to connect it to create the complete SoC.

This is not a TLM 2.0 component—the interfaces are standard SystemC buffers, so the description is less detailed. However it serves to illustrate an important general technique when using SystemC—how to interact with the operating system functions.

The problem is that many operating system calls block. Consider modeling the terminal as a thread which reads characters from a console window. This will block until characters are typed. However the block does not use the SystemC `wait` call, so SystemC is not aware that the thread has yielded. The simulation will hang until characters are received.

This implementation of the terminal will show how to wrap non-blocking versions of operating system functions with SystemC events, to give versions that block correctly using SystemC `wait`, so allowing the thread to yield.

### 7.1. SystemC Terminal Module Design

The terminal provides SystemC buffer to model the Rx and a port to model the Tx pins of a serial connection. The visualization is provided by a Linux `xterm` running in a child process, with communication through a pseudo-TTY<sup>7</sup>.

Two SystemC processes are used, one a method waiting for bytes from the UART in the Rx buffer, the other a thread waiting for bytes from the `xterm`. When bytes are received in the Rx buffer, they are written to the `xterm`. When bytes are received from the `xterm` they are written to the Tx port. The key interfaces are shown in Figure 7.

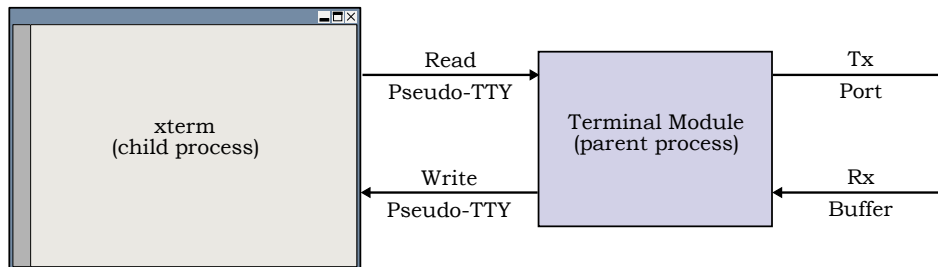

**Figure 7. SystemC terminal model using a `xterm` child process.**

The difficulty is in waiting for the `xterm`. As described above, reading from the pseudo-TTY is an operating system call, and does not use the SystemC `wait`, so the thread will not yield and the simulation will block. Instead the pseudo-TTY is set up to use asynchronous I/O, which will cause a Linux `SIGIO` to be raised whenever data is available to read. The event handler for `SIGIO` will then notify a SystemC event, and it is this SystemC event on which the thread can safely wait.

### 7.2. Terminal Module Class Definition

#### 7.2.1. Mapping Signals to Class Instances

The operating system signal handlers require C style linkage, so cannot be used with C++ member functions (the same issue addressed by the Or1ksim wrapper in Section 4.2.6). Thus the `SIGIO` handler will be a static function. However each instance (there could be multiple

<sup>7</sup> The description here is specific to Linux. A future version of this application note will describe use under Microsoft Windows.

terminals in a simulation) will have a different file descriptor, which can be used to identify the owning class instance.

The set of mappings from file descriptor to class instance is held in a linked list with static head pointer. The **struct Fd2Inst** is provided for that list, with entries for the file descriptor, instance and a pointer to the next in the list.

### 7.2.2. The SystemC Class

**TermSC** is declared as a standard SystemC class, with a buffer for bytes coming in, and a port for bytes out (which will connect to a buffer in the UART). In this case it has a custom destructor as well as constructor, which will be used to kill the child process running the xterm when the class is deleted.

### 7.2.3. Setting up the xterm

A set of utility functions are provided to set up the xterm. A function, **xtermRead**, is provided to read from the xterm and a function, **xtermWrite** to write to the xterm. Both these functions are blocking on the operating system. The write function should always be able to write with minimal delay. However the read function must only be called when the **SIGIO** signal handler has determined input is available, in order to avoid blocking the SystemC simulation.

There is some internal state to hold the pseudo-TTY file descriptors and the process ID of the xterm (so it can be killed by the destructor). It is the slave file descriptor that is used for both input and output.

### 7.2.4. Signal and event handling

The **SIGIO** signal handler (**ioHandler**) is declared static as noted above. The static **instList** of type **Fd2Inst** points to the list of mappings from file descriptor to class instance.

The SystemC event used to signal when input is available is pointed to by **ioEvent**.



#### Caution

It is essential that the event is declared as a pointer. If the event itself were declared here, it would be available at elaboration, and would crash the system (try it!).

The solution is to declare the pointer and allocate the event instance dynamically when the xterm is created. The memory can be freed from the destructor on termination.

## 7.3. Terminal Module Class Implementation

The implementation is a standard SystemC module communicating via the Rx buffer and Tx port. It has a SystemC method sensitive to writes to the Rx buffer and a SystemC thread listening to the xterm.

The setup of the pseudo-TTYs and the xterm in a separate process uses standard operating system functions, not described further here. The key factor is that the file descriptor for the pseudo-TTY to the xterm is set up to be asynchronous, with Linux signal **SIGIO** raised when input is available and handled by the **ioHandler()** function.

### 7.3.1. SystemC Processes

The method listening to the UART, **rxMethod** is sensitive to writes to the **rx** buffer. When triggered, the character is read from the buffer and immediately copied to the xterm. Although this is a blocking operating system write, it should return with minimal delay. In an environment where any blocking were a concern, a non-blocking write could be used instead.

The thread listening to the xterm, **xtermThread** sits in a perpetual loop, waiting on the SystemC event pointed to by **ioEvent**. This will safely allow the thread to yield to the SystemC scheduler until a character is ready.

When input is available, the event is notified (see Section 7.3.2). The thread can safely make an operating system read to get the character, knowing that data is definitely available.

### 7.3.2. Signal and event handling

During initialization of the xterm the SystemC event, **ioEvent** is allocated:

```
ioEvent = new sc_core::sc_event();
```

When **ioHandler** is called in response to a Linux **SIGIO** event, it does not know which pseudo-TTY was responsible. The file descriptor responsible is identified by using an operating system **select** call. Using the mappings in **instList**, the corresponding class instance can be identified and its **ioEvent** notified.

```
for(Fd2Inst *cur = instList; cur != NULL ; cur = cur->next) {
 if(FD_ISSET(cur->fd, &readFdSet)) {
 (cur->inst)->ioEvent->notify();
 }
}
```

This event then allows the **xtermThread** to run and read a character.

## 7.4. The Complete SoC

### 7.4.1. The Model Main Program

The structure of the main program (**SimpleSoC.cpp**) is similar to that for the logger test program (see Section 5.3). The TLM 2.0 header and the headers for each module (Or1ksim ISS, UART and terminal) are included.

```
#include "tlm.h"
#include "Or1ksimExtSC.h"
#include "UartSC.h"
#include "TermSC.h"
```

As before the main program (**sc\_main**) takes as arguments the Or1ksim configuration file and OpenRISC 1000 image. Instances of the three modules are declared.

```
Or1ksimExtSC iss("or1ksim", argv[1], argv[2]);
UartSC uart("uart", iss.isLittleEndian());
TermSC term("terminal");
```

The endianism for the UART is set using the public utility function in **Or1ksimExtSC**. The TLM sockets of UART and ISS can be connected:

```
iss.dataBus(uart.bus);
```

The Rx buffer in the UART is connected to the Tx port in the terminal and the Rx buffer in the terminal is connected to the Tx port in the UART.

```
uart.tx(term.rx);
term.tx(uart.rx);
```

The simulation can then be started with a call to **sc\_start**.

### 7.4.2. Test Program to Run on the Or1ksim ISS

The test program, **uart\_loop.c** is a simple polling loop back driver of the UART. Characters are read and immediately echoed back.

A **volatile** structure is declared for the UART registers, with **#defined** constants for the base address and the register bits of interest

```
#define BASEADDR 0x90000000
#define BAUD_RATE 9600
```



```

#define CLOCK_RATE 100000000 // 100 Mhz

struct uart16450
{
 volatile unsigned char buf; // R/W: Rx & Tx buffer when DLAB=0
 volatile unsigned char ier; // R/W: Interrupt Enable Register
 volatile unsigned char iir; // R: Interrupt ID Register
 volatile unsigned char lcr; // R/W: Line Control Register
 volatile unsigned char mcr; // W: Modem Control Register
 volatile unsigned char lsr; // R: Line Status Register
 volatile unsigned char msr; // R: Modem Status Register
 volatile unsigned char scr; // R/W: Scratch Register
};

#define UART_LSR_TEMT 0x40 // Transmitter serial register empty
#define UART_LSR_THRE 0x20 // Transmitter holding register empty
#define UART_LSR_DR 0x01 // Receiver data ready

#define UART_LCR_DLAB 0x80 // Divisor latch access bit
#define UART_LCR_8BITS 0x03 // 8 bit data bits

```

The utility functions to set and clear flags in the UART (see Section 6.5) are reused here, modified for C rather than C++ and **volatile** register arguments. They are included from the file **binutils.c**

```
#include "bitutils.c"
```

The main program declares a pointer to the UART register structure, **uart**, at the base address. Initialization requires setting the divisor latch, to divide the main clock down to 16 x the baud rate and setting 8-bit data.

```

volatile struct uart16450 *uart = (struct uart16450 *)BASEADDR;
unsigned short int divisor;

divisor = CLOCK_RATE/16/BAUD_RATE; // DL is for 16x baud rate

set(&(uart->lcr), UART_LCR_DLAB); // Set the divisor latch
uart->buf = (unsigned char)(divisor & 0x00ff);
uart->ier = (unsigned char)((divisor >> 8) & 0x00ff);
clr(&(uart->lcr), UART_LCR_DLAB);

set(&(uart->lcr), UART_LCR_8BITS); // Set 8 bit data packet

```

The remainder of the program is a perpetual loop:

- Wait for a character in the read buffer (flag **DR** of the line status register is set).
- Read the character from the buffer and print it.
- Wait for the transmit buffer to clear (flags **TEMT** and **THRE** of the line status register are set).
- Write the character back.

```

while(1) {
 unsigned char ch;

 do { // Loop until a char is available
 ;
 } while(is_clr(uart->lsr, UART_LSR_DR));
}

```

```

ch = uart->buf;

simputs("Read: '"); // Log what was read
simputc(ch);
simputs("'\n");

do { // Loop until the transmit register is free
;
} while(is_clr(uart->lcr, UART_LSR_TEMT | UART_LSR_THRE));

uart->buf = ch;
}

```

### 7.4.3. Compiling and Running the Model

Compilation uses the same command lines as the standalone test of the Or1ksim wrapper with the logger (see Section 5.5), but this time links in the UART and terminal; rather than the logger.



#### Important

Since **Or1ksimExt** is a derived class of **Or1ksim**, linking should include the compiled base class, **Or1ksimSC.o** as well as the derived class, **Or1ksimExtSC.o**.

The Or1ksim configuration is also unchanged. Like the logger, the UART registers start at address 0x90000000 and are 8 bytes long.

Running the model requires specifying the configuration file (unchanged) and the binary executable (this time the UART loop back program).

```
./SimpleSocSC ../simple.cfg progs_or32/uart_loop
```

The xterm terminal should appear. Select it and type some characters. The window running the model, will show the logged output from the terminal, reporting the same characters being written, as shown in Figure 8.

```

$./SimpleSocSC ../simple.cfg progs_or32/uart_loop

 SystemC 2.2.0 --- May 16 2008 10:30:46
 Copyright (c) 1996-2006 by all Contributors
 ALL RIGHTS RESERVED
Reading script file from '../simple.cfg'...

... <Or1ksim initialization messages>

Read: 'F'
Read: 'a'
Read: 'r'

... <more Or1ksim output>

Read: '!'
Read: '!'
Read: '!'

```

**Figure 8. UART loop back program log output.**

At the same time the characters will be echoed on the xterm, as shown in figure Figure 9.

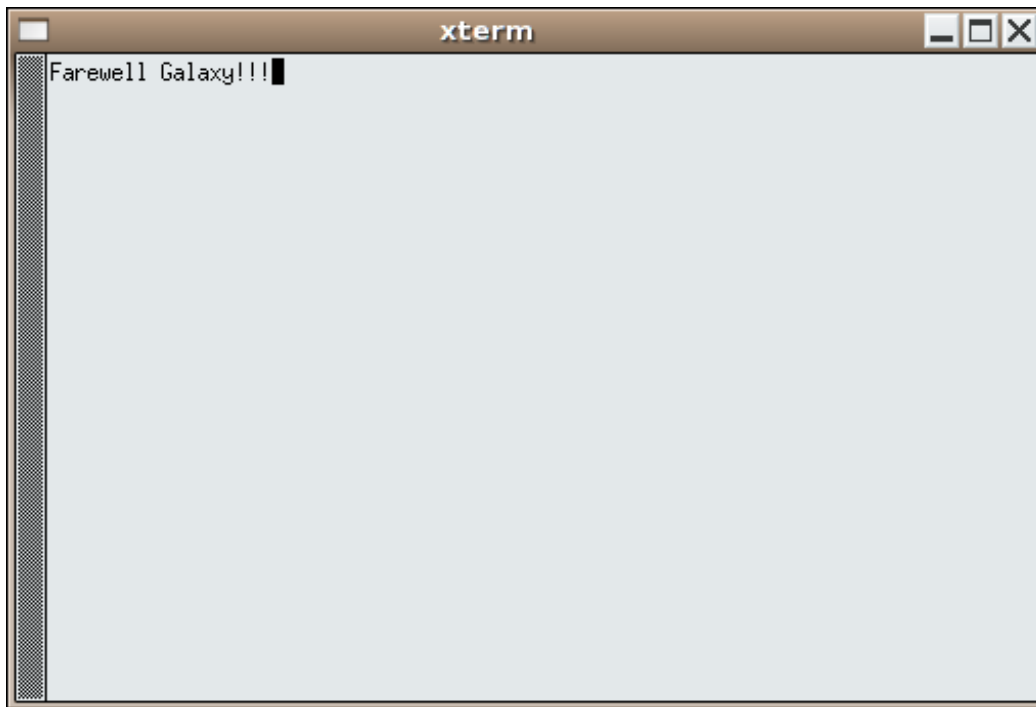

**Figure 9. xterm with the UART loop back program running.**

Well it makes a change from "Hello World!".

As an exercise, rebuild the model, removing the call to `wait` in the `Or1ksimExtSC::doTrans` function. Observe that the program hangs without accepting any characters. The reason for this is given in the description of `doTrans` in Section 6.3.

A debugger connected to the model will show that execution is stuck in Or1ksim ISS, waiting for the data ready flag to be set in the UART. This can never occur, since neither UART nor terminal are given the chance to execute the threads that would set this flag.

#### 7.4.4. Model Timing

This model is completely untimed. It executes the behavior of the design, and for that reason such models are useful in system verification.

The next stages will add timing to this model. To allow this to be demonstrated, add some logging to the UART and terminal to report the timing of reads and writes.

Edit the `rxThread` in `UartSC`, to print out the time when a character is received from the terminal<sup>8</sup>.

```
void
UartSC::rxThread()
{
 // Loop woken up when a character is written into the buffer from the terminal.

 while(true) {
 regs.rbr = rx.read(); // Blocking read of the data
```

<sup>8</sup> The use of `printf` and C `stdio` is unfortunate. It would be better to use C++ stream IO. However there seems to be an interaction with either SystemC or the asynchronous IO of the xterm, which makes stream IO to standard output unreliable

```

 sc_core::sc_time now = sc_core::sc_time_stamp();
 printf("Char read at %12.9f sec\n", now.to_seconds());

 set(regs.lsr, UART_LSR_DR); // Mark data ready

 if(isSet(regs.ier, UART_IER_ERBFI)) { // Send interrupt if enabled
 genIntr(UART_IIR_RDI);
 }
}
} // rxThread()

```

Similarly edit the `rxThread` in `TermSC`, to print out the time when a character is received from the UART.

```

void
TermSC::rxThread()
{
 while(true) {
 unsigned char ch = rx.read(); // Blocking read from the buffer

 xtermWrite(ch); // Write it to the screen

 sc_core::sc_time now = sc_core::sc_time_stamp();
 printf("Char written at %12.9f sec\n", now.to_seconds());
 }
} // rxThread()

```

In both cases the C standard IO header will be needed at the top of the file (`UartSC.cpp` and `TermSC.cpp`):

```
#include <stdio.h>
```

The model can now be rerun as before, and will print out precise timing (use of 9 decimal places ensures that granularity at least as fine as the 100MHz CPU clock will be seen). The output is shown in Figure 10.

```

$./SimpleSocSC ../simple.cfg progs_or32/uart_loop

 SystemC 2.2.0 --- May 16 2008 10:30:46
 Copyright (c) 1996-2006 by all Contributors
 ALL RIGHTS RESERVED
Reading script file from '../simple.cfg'...

... <Or1ksim initialization messages>

Char read at 0.000000000 sec
Read: 'F'
Char written at 0.000000000 sec
Char read at 0.000000000 sec
Read: 'a'
Char written at 0.000000000 sec
Char read at 0.000000000 sec
Read: 'r'

... <Lots more output>

```

**Figure 10. UART loop back program log output with timing annotation.**



As can be seen all the reads and writes occur at time zero.

## 8. Adding Synchronous Timing to the Model

The current models are all untimed. In the TLM 2.0 components (**Or1ksimExtSC** and **UartSC**) the delay parameter to the blocking transport function has been ignored by setting it to zero.

In this section, the models are extended to synchronize explicitly with the SystemC clock.

The synchronization is not perfect—the underlying Or1ksim ISS executes outside the SystemC world. Synchronization is only possible when it makes an upcall for read or write. In Section 9 this model will be further extended to add control over the underlying ISS and its interaction with SystemC time.

### 8.1. Summary of Changes Required for Synchronous Timing

Each module of the existing SoC requires some changes. New classes, **Or1ksimSyncSC**, **UartSyncSC** and **TermSyncSC** are derived from the existing classes to provide added functionality. In addition the underlying Or1ksim ISS library will need extending, the main program will need modifying to use these new classes.

- **Or1ksimSyncSC**. A public function to report the clock rate of the underlying Or1ksim ISS is added (requiring an extension to the Or1ksim library), and the transport function, **doTrans** modified to add timing information.
- **UartSyncSC**. This now models the time taken to put a character out on the Tx wire, so must know its input clock rate (in this SoC, the Or1ksim clock rate), so that baud rate can be calculated from the divisor latch. Also models the true time to process a read or write on the bus and returns this with the transaction response.
- **TermSyncSC**. This now models the time taken to put a character out to the UART, so must know its baud rate. This requires an updated thread listening to the xterm, so that the baud rate delay can be added.
- Or1ksim ISS library. Information functions are added to return the model clock rate (used as input clock rate for the UART) and to determine the time spent executing instructions (so **Or1ksimSyncSC** can determine the synchronization time with SystemC).
- A new main program **SyncSocSC.cpp** to build the new classes into a synchronized SoC. Information functions are added to return the model clock rate (used as input clock rate for the UART) and the time spent executing instructions (so **Or1ksimSyncSC** can determine the synchronization time with SystemC).

### 8.2. Extending the Or1ksimExtSC Wrapper Module

#### 8.2.1. Adding Clock Rate and Timing Functions to the Or1ksim Library

Three additional functions are needed in the Or1ksim library to support synchronized timing. The UART will need to know the clock rate of the model (to work out the baud rate from the value of the divisor latch). The **Or1ksimSyncSC** class itself will need a pair of functions, one to set a timing point in the ISS the second to return the amount of time since the last timing point. This the amount of time the underlying ISS has used when synchronizing with SystemC.

The three additional functions are simple additions. The clock rate is a configuration parameter, while a run time count of instructions executed is already maintained. An extra record in the run-time structure allows a time to be recorded (in seconds through dividing the count by the clock rate), which can be compared in subsequent calls to give the ISS time used since the last time point<sup>9</sup>.

<sup>9</sup> This is a loosely timed model. The timing from the ISS is approximate—it does not model the microarchitecture in detail. Cycle estimates will not be exact—that requires a fully cycle accurate model.

- `unsigned long int or1ksim_clock_rate();`  
**or1ksim\_clock\_rate** returns the Or1ksim ISS clock rate in Hz. This information will be used by the UART to allow it to set its baud rate.
- `void or1ksim_set_time_point();`  
**or1ksim\_set\_time\_point** records the current ISS simulation time (clock cycles divided by clock rate) in the run-time data structure.
- `double or1ksim_get_time_period();`  
**or1ksim\_get\_time\_period** returns the time in seconds since the last time point was set. This function is needed to keep the SystemC model of time due to instruction set processing accurate, both in the synchronous SoC and when temporal decoupling is added.

### 8.2.2. Or1ksimSyncSC Module Class Definition

The new module class, **Or1ksimSyncSC** is derived from the existing **Or1ksimExtSC** module class. The header of the base class, **Or1ksimExtSC** is included and the new class derived from that base class.

```
#include "Or1ksimExtSC.h"

class Or1ksimSyncSC
 : public Or1ksimExtSC
{
```

A custom constructor must be defined, but has the same arguments as the base class constructor, to which it will pass its arguments.

The new Or1ksim library call to give the clock rate is wrapped by a public function<sup>10</sup>.

```
unsigned long int getClockRate();
```

The virtual function, **doTrans** function is reimplemented—it will replace the call to **doTrans** in the base class to add timing synchronization.

### 8.2.3. Or1ksimSyncSC Module Class Implementation

The custom constructor passes its arguments directly to the base class constructor. It then uses the Or1ksim library function, **or1ksim\_set\_time\_point** to set an initial time point at the start of simulation. The first call to **or1ksim\_get\_time\_period** will return the time since the ISS started.

The **doTrans** function (which is used for both read and write) is extended from the version used with **Or1ksimExtSC** to synchronize with the SystemC clock.

There are two components to the time taken in this model, the time taken by the Or1ksim ISS and the time taken in any peripherals. At the time of an upcall, the SystemC wrapper thread will not have yielded control since either initialization or the last upcall, when a time point was set in the ISS using **or1ksim\_set\_time\_point**.

A call to **or1ksim\_get\_time\_period** gives the time used by the ISS in this period. This is used as the argument to **wait**, allowing any other threads in the SystemC world to run until the calculated simulation time is reached.

```
wait(sc_core::sc_time(or1ksim_get_time_period(), sc_core::SC_SEC));
```

<sup>10</sup> The use of unsigned long int reflects the usage in the Or1ksim ISS. The designers do not anticipate usage to model designs in excess of 4GHz!

At this time the blocking transport function of the simple initiator socket is called with the payload and specifying a zero time offset (since the call to `wait` means the thread is synchronized with the SystemC clock).

```
sc_core::sc_time delay = sc_core::SC_ZERO_TIME;
dataBus->b_transport(trans, delay);
```

On return, the `delay` parameter will have been updated with any additional delay due to the transaction—in this case an estimate of the number of cycles to read or write the relevant UART register.

However, since this is a synchronized model, the target will have called `wait` to model the time taken to read or write, so `delay` will still be zero on return.

The read or write is now complete. A new time point is set with `set_time_point` before control is returned to the ISS

```
or1ksim_set_time_point();
```

The utility `getClockRate` is a simple wrapper for the underlying Or1ksim library function (see Section 8.2.1). It will be used in the main program (see Section 8.5).

```
unsigned long int
Or1ksimSyncSC::getClockRate()
{
 return or1ksim_clock_rate();
} // getClockRate()
```

### 8.3. Extending the UartSC Module Class

A new class, `UartSyncSC` derived from `UartSC` implements the additional functionality for synchronized timing.

The time taken for the serial pulses (start, data, parity, stop bits) on the real UART will be modeled as a delay before writing data onto the Tx output port. The corresponding delay on the Rx buffer port will be modeled by the terminal writing into that port<sup>11</sup>.

The TLM 2.0 socket modeling the bus is extended to model the time taken for reads to and writes from the bus.

#### 8.3.1. UartSyncSC Module Class Definition

The class definition (in `UartSyncSC.h`) includes the header of the base class and defines two new constants to represent the delay in reading and writing in nanoseconds.

```
#define UART_READ_NS 60 // Time to access the UART for read
#define UART_WRITE_NS 60 // Time to access the UART for write
```

The class is derived directly from the base class, `UartSC`. A new custom constructor is needed, with an additional parameter specifying the input clock rate. This is used in conjunction with the divisor latch to specify the baud rate.

```
UartSyncSC(sc_core::sc_module_name name,
 unsigned long int _clockRate,
 bool _isLittleEndian);
```

<sup>11</sup> This is not the ideal solution. The delay is really a property of the channel, so should be modeled by a derived class of the standard SystemC buffer which provides a defined delay between data being written and data availability being signaled. The approach used here (transmitter models the delay) represents a practical compromise.



The **busThread** thread is reimplemented to add the timing delay (as a call to **wait** in transmitting a character as described above).

The blocking transport function, **busReadWrite** is reimplemented to add in the bus delays in reading and writing. Again this will be achieved by calls to **wait**, so keeping the model synchronous.

The **busWrite** must also be reimplemented, since any change to the divisor latch or the line control register (which specifies the bit format being sent on the wire) could affect the baud rate and timing for **busThread**

A new utility function, **resetCharDelay** is defined to compute the delay in putting a character on the Tx port from the clock rate, divisor latch and line control register.

Two new member variables are declared, to hold the clock rate and the calculated delay to put a character on the Tx port.

### 8.3.2. UartSyncSC Module Class Implementation

The custom constructor passes the name and **\_isLittleEndian** flag to the base class constructor. The clock rate is saved in the state variable, **clockRate**.

```
UartSyncSC::UartSyncSC(sc_core::sc_module_name name,
 unsigned long int _clockRate,
 bool _isLittleEndian) :
 UartSC(name, _isLittleEndian),
 clockRate(_clockRate)
{
}
/* UartSyncSC() */
```

The new version of **busThread** adds only one line to the version in the base class. A call to **wait( charDelay )** is added when the transmit request is received (notified on the SystemC event, **txReceived**).

```
wait(txReceived); // Wait for a Tx request
wait(charDelay); // Wait baud delay
tx.write(regs.thr); // Send char to terminal
```

The new version of **busReadWrite** draws most of its functionality from the base class version. However it then synchronizes with a time delay for the read or write access. Since the thread is now synchronous, a time delay of zero is returned with the transaction.

```
void
UartSyncSC::busReadWrite(tlm::tlm_generic_payload &payload,
 sc_core::sc_time &delay)
{
 UartSC::busReadWrite(payload, delay); // base function

 switch(payload.get_command()) {
 case tlm::TLM_READ_COMMAND:
 wait(sc_core::sc_time(UART_READ_NS, sc_core::SC_NS));
 delay = sc_core::SC_ZERO_TIME;
 break;

 <code for write commands etc>
```

The new version of **busWrite** similarly relies on the base class for most of its functionality.

```
void
UartSyncSC::busWrite(unsigned char uaddr,
 unsigned char wdata)
{
 UartSC::busWrite(uaddr, wdata);
}
```

However any change to the divisor latch or line control register could change the baud rate or the number of bits in each Tx transmission, and hence the modeled delay to send a character.

The function identifies if this has happened and if so calls **resetCharDelay** to recalculate the delay.

```
switch(uaddr) {
case UART_BUF: // Only change if divisorLatch update (DLAB=1)
case UART_IER:
 if(isSet(regs.lcr, UART_LCR_DLAB)) {
 resetCharDelay();
 }
 break;

case UART_LCR:
 resetCharDelay(); // Could change baud delay
 break;
}
```

The time taken to put a character on the Tx line is the product of the time taken to put one bit on the line (the inverse of the baud rate) and the bits required for the character (start bit, data bits, optional parity bit, stop bit(s)). The baud rate is determined by the input clock rate and the 16-bit divisor latch.



#### Note

The divisor latch for a 16450 divides the input clock to yield an internal clock 16x the baud rate (i.e. not the actual baud rate itself).

The 16450 specification supports an input clock up to 24 MHz, so the 16 bit divisor latch can yield an internal clock for rates down to 50 baud. However for a software model this limitation can be ignored. Faster input clocks can be specified, but it will not be possible to configure a 16-bit divisor latch for very low baud rates.

The number of bits to send a character is determined by the line control registers. There is always a stop bit, there can be 5-8 data bits, an optional parity bit and 1, 1.5 or 2 stop bits. The **resetCharDelay** function calculates the total delay.

## 8.4. Extending the TermSC Module Class

A new class, **TermSyncSC** derived from **TermSC** implements the additional functionality for synchronized timing.

As with the UART (see Section 8.3), the terminal will model the time taken to put the bits of a character on its Tx port. This mirrors the arrangement with the UART, so when the two are connected, delays in both directions are correctly modeled.

### 8.4.1. TermSyncSC Module Class Definition

The new class, **TermSyncSC** is derived from **TermSC**. The header for that class is included and the new class derived from it.

```
#include "TermSC.h"

class TermSyncSC
```

```

: public TermSC
{

```

A new custom constructor is needed, which takes a second argument to specify the baud rate.

```

TermSyncSC(sc_core::sc_module_name name,
 unsigned long int baudRate);

```

The `xtermThread` thread will be reimplemented. No further derived classes are anticipated, so this function is declared `private` and not marked as `virtual`.

A variable is needed to hold the baud rate. For convenience the class does not hold the baud rate, but the corresponding delay that this represents in sending a character.

```

sc_core::sc_time charDelay;

```

#### 8.4.2. TermSyncSC Module Class Implementation

The custom constructor calls the base class constructor to set the module name. The body of the constructor is calculates the delay due to the baud rate. There is no configurability (this terminal supports 1 start, 8 data, 0 parity and 1 stop bits only), so this is a one off calculation.

```

TermSyncSC::TermSyncSC(sc_core::sc_module_name name,
 unsigned long int baudRate) :
 TermSC(name)
{
 charDelay = sc_core::sc_time(10.0 / (double)baudRate, sc_core::SC_SEC);
}
/* TermSyncSC() */

```

The `xtermThread` thread is almost identical to the base class version. A single line is added after the character is read from the xterm and before it is written to the port to add the modeled baud rate delay.

```

int ch = xtermRead(); // Should not block

wait(charDelay); // Model baud rate delay
tx.write((unsigned char)ch); // Send it

```

#### 8.5. Main Program for the Synchronous Model

As with the untimed SoC (see Section 7.4.1), the main program includes the headers for TLM 2.0 and the component modules, but this time using the synchronously timed versions.

```

#include "tlm.h"
#include "Or1ksimSyncSC.h"
#include "UartSyncSC.h"
#include "TermSyncSC.h"

```

The baud rate for the terminal is defined as a constant for convenience.

```

#define BAUD_RATE 9600

```

As before the main program (`sc_main`) takes as arguments the Or1ksim configuration file and OpenRISC 1000 image. Instances of the three modules are declared, but now have additional arguments. The UART requires an input clock rate—obtained from the ISS via the `Or1ksimSyncSC` public utility function, `getClockRate` (see Section 8.2.3). The Terminal requires its baud rate to be set.

```

Or1ksimSyncSC iss("or1ksim", argv[1], argv[2]);
UartSyncSC uart("uart", iss.getClockRate(), iss.isLittleEndian());

```

```
TermSyncSC term("terminal", BAUD_RATE);
```

The remainder of the program, connecting components and starting the simulation is identical to the untimed version.

## 8.6. Compiling and Running the Synchronous Model

Compilation uses the same command lines as the untimed model (see Section 7.4.3), but with the synchronized versions of the modules and main program.



### Important

Since `Or1ksimSync` is a derived class of `Or1ksimExt`, `Or1ksimExt`, linking should include the compiled base classes, `Or1ksimSC.o` and `Or1ksimExtSC.o` as well as the derived class, `Or1ksimSyncSC.o`. Similarly the compiled base classes of `UartSyncSC` and `TermSyncSC` should also be included.

The Or1ksim configuration is completely unchanged, and the embedded code running on the Or1ksim ISS is the same (`uart_loop`).

The command line to run the model is unchanged, but uses the synchronized version of the model

```
./SyncSocSC ../simple.cfg progs_or32/uart_loop
```

Once again the xterm terminal should appear. Select it and type some characters. The window running the model, will show the logged output from the terminal, reporting the same characters being written and timing of the reads and writes. However this time, the time progresses as the characters are written, as shown in Figure 11.

```
$./SyncSocSC ../simple.cfg progs_or32/uart_loop

 SystemC 2.2.0 --- May 16 2008 10:30:46
 Copyright (c) 1996-2006 by all Contributors
 ALL RIGHTS RESERVED
 Reading script file from '../simple.cfg'...

 ... <Or1ksim initialization messages>

 Char read at 0.060059107 sec
 Read: 'F'
 Char written at 0.061114010 sec
 Char read at 0.070717297 sec
 Read: 'a'
 Char written at 0.071772200 sec
 Char read at 0.077270287 sec
 Read: 'r'
 Char written at 0.078325190 sec

 ... <Lots more output>
```

**Figure 11. UART loop back program log output.**

The read timing is as the character leaves the terminal, *after* the terminal has added the baud rate delay. The write timing is as the character leaves the UART after the echo loop in the embedded application on the Or1ksim ISS and *after* the UART has added the baud-rate delay. So the timing from the *read* message to the *write* message should be the time for the UART delay for the current baud rate and packet bits plus the execution time for the code to echo the character on the Or1ksim ISS.



The UART was initialized to use 1 start bit, 8 data bits and 1 stop bit, which at 9600 baud takes around 1040 $\mu$ s. The time shown in Figure 11 for the first character to be read and written back is 1055 $\mu$ s. This seems reasonable, allowing approximately 1500 cycles (15 $\mu$ s at 100MHz) for the Or1ksim ISS to process the read and write code.

## 9. Adding Temporal Decoupling to the Model

In this case study temporal decoupling is added to the TLM 2.0 model of an SoC. The SoC model with arbiter from the previous example is reused.

### 9.1. What is Temporal Decoupling

The idea of temporal decoupling is very simple and has been around for a long time (see for example A loosely coupled parallel LISP execution system. ). In a parallel system, the various threads keep their own local time, and only synchronize when they need to communicate with each other.

TLM 2.0 provides some convenience classes to help threads implement temporal decoupling. The nomenclature used by these classes can be more than a little confusing—the following should help to explain how the technique works.

There are two key points about temporal decoupling.

1. Temporal decoupling is a property of *threads*, not module classes. So it is each *thread* that must keep track of its local view of time.
2. Nothing in the TLM 2.0 system checks a program is following the rules. It is up to each thread to ensure it is compliant.

Not all threads need use temporal decoupling, although the more that do, the greater the potential model efficiency. In general temporal decoupling is only appropriate for threads using TLM 2.0 blocking interfaces for their communication—typically loosely timed models. Where temporal decoupling is implemented it is managed by the threads driving *initiator* sockets.

#### 9.1.1. Timing Concepts

TLM 2.0 defines four different timing entities to describe temporal decoupling. These are illustrated in Figure 12.

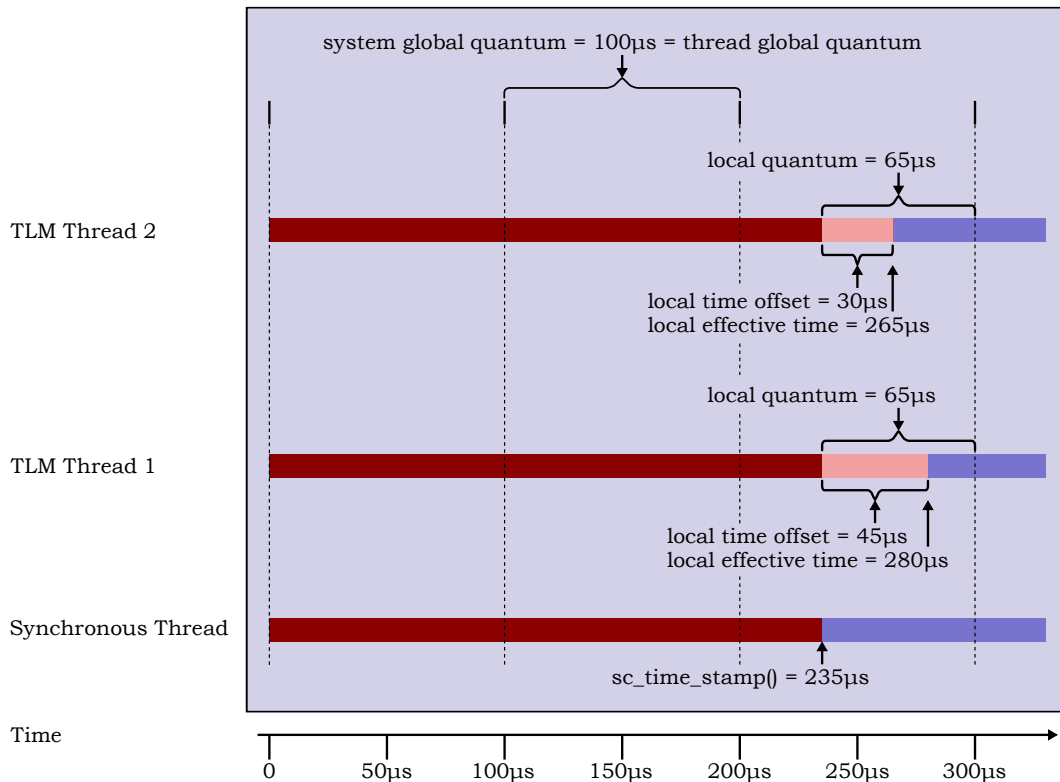

**Figure 12. Diagram illustrating temporal decoupling**

|                         |                                                                                                                                                                                                                                                                                                                                                                                                                                                                                                                                                                                                                                                                                                                                                 |
|-------------------------|-------------------------------------------------------------------------------------------------------------------------------------------------------------------------------------------------------------------------------------------------------------------------------------------------------------------------------------------------------------------------------------------------------------------------------------------------------------------------------------------------------------------------------------------------------------------------------------------------------------------------------------------------------------------------------------------------------------------------------------------------|
| (System) Global Quantum | This represents the time unit on which all threads synchronize. For example a <i>Global Quantum</i> of 100µs means that all threads synchronize on 100µs 200µs, 300µs etc. Although the TLM 2.0 standard refers to this as just the Global Quantum, it is a system wide concept and for clarity this application note refers to it as the <i>System Global Quantum</i> .                                                                                                                                                                                                                                                                                                                                                                        |
| (Thread) Global Quantum | <p>This represents the time unit on which a particular thread synchronizes. The TLM 2.0 standard allows different threads to have their own private time unit of synchronization, which is very confusingly also referred to in the standard as the Global Quantum.</p> <p>To avoid confusion, in this application note, the term <i>Thread Global Quantum</i> is used to mean the global quantum used by a particular thread.</p> <p>Having different values for the global quantum in different threads is a recipe for complete confusion, while offering few advantages. The user is strongly recommended to set the Thread Global Quantum to the same value as the System Global Quantum when the thread is created and not change it.</p> |
| Local Quantum           | <p>For each thread, this represents the time remaining from the current SystemC time (as returned by <code>sc_time_stamp</code>) until the end of the current Thread Global Quantum.</p> <p>For example if the current SystemC time stamp is 235µs and the Thread Global Quantum is 100µs, then the Local Quantum will be 65µs—the time until the 300µs Thread Global Quantum synchronization is due.</p> <p>If the recommendation that all threads set their Thread Global Quantum to be the same as the System Global Quantum is followed, then the value of the Local Quantum will be the same in all threads.</p>                                                                                                                           |
| Local Time Offset       | <p>Each thread is allowed to hold a local view of time, which runs ahead of the current SystemC time. This is known as the <i>Local Time Offset</i></p> <p>The Local Time Offset must not take the thread's local view of time past the next Thread Global Quantum, i.e. it cannot exceed the Local Quantum.</p> <p>For example if the current SystemC time stamp is 235µs and the Thread Global Quantum is 100µs, then a local time offset of 45µs would represent a thread local effective time of 280µs.</p>                                                                                                                                                                                                                                 |

### 9.1.2. The Global Quantum Class, `t1m_global_quantum`

TLM 2.0 defines a singleton class<sup>12</sup> which can be used to hold the system global quantum. A set of functions to manipulate the global quantum are provided.

**instance** Returns a reference to the singleton global quantum object

<sup>12</sup> A singleton is a class of which only one instance can be created. The constructor is declared private (so no other class can create it), and a static function is provided to return the single instance. This static function will create the single instance the first time it is called, and thereafter just return a reference to that same instance. Singleton classes are useful for holding centrally required values and providing centrally required functions in a system, where having duplicate provision would lead to incorrect behavior.

|                              |                                                                                                                          |
|------------------------------|--------------------------------------------------------------------------------------------------------------------------|
| <b>set</b>                   | Sets the global quantum (as a SystemC <b>sc_time</b> object)                                                             |
| <b>get</b>                   | Returns the value of the global quantum                                                                                  |
| <b>compute_local_quantum</b> | Returns the local quantum, i.e. the time from the current SystemC time stamp to the next multiple of the global quantum. |

The intention is that at start up the main program should set the system global quantum in the singleton **tlm\_global\_quantum** object. All threads can then set their thread global quantum by getting the value from the **tlm\_global\_quantum** object.

### 9.1.3. TLM 2.0 Quantum Keepers

TLM 2.0 provides a utility class for threads to keep track of their thread global quantum, local quantum and local time offset. This is in the **tlm\_utils** namespace (like the convenience sockets) with a header in **tlm\_utils/tlm\_quantumkeeper.h**.

A module will instantiate one quantum keeper for each thread that is uses temporal decoupling, initializing them in the constructor.

Two functions are provided to manage the thread global quantum: **set\_global\_quantum** to set the value and **get\_global\_quantum**. Typically a module constructor will get the *system* global quantum with a call to the singleton **tlm\_global\_quantum** and immediately use that to set the thread global quantum for each thread's quantum keeper.

One function is provided to manage the local quantum. The **reset** function calls **compute\_local\_quantum** to calculates the local quantum from the time stamp and the global quantum (which is done by calling the **compute\_local\_quantum** in the singleton **tlm\_global\_quantum** object) and sets the local time offset to zero.

Typically a constructor will call **reset** for each thread immediately after setting the thread global quantum. The **compute\_local\_quantum** in the quantum keeper is **protected**, so cannot be called directly (which seems to be an omission). If the value of the local quantum is needed, this can be obtained using the **compute\_local\_quantum** function in the singleton **tlm\_global\_quantum** object.

Four functions are provided to manage the local time offset. **set** sets the local time offset to a particular value, **inc** increments by a given value and **get\_local\_time** returns the current value of the local time offset. **get\_current\_time** computes the local effective time, i.e. the SystemC time stamp plus the local time offset<sup>13</sup>. The intention is that a thread advances model time, it will call **set** and **inc** to update the local decoupled view of time.

Two functions are provided to handle synchronization. The test **need\_sync** returns true if the local time offset exceeds the local quantum. **sync** calls **wait** for the local time offset, synchronizing the thread with the global SystemC view of time, and allowing other threads to catch up. It then calls **reset** to update the local quantum and zero the local time offset. **sync** should always be called when **need\_sync** is true, but may be called at any other time if required.

### 9.1.4. Other Styles of Temporal Decoupling

TLM 2.0 presents one model of temporal decoupling, with an explicit regular synchronization time.

Other temporal decoupling models can build on the TLM 2.0 infrastructure, for instance to remove the regular synchronization time, and instead only synchronize when the local time

<sup>13</sup> The naming is not consistent. **get\_local\_time** should have been just **get** for consistency with **set** and **inc**. **get\_current\_time** would be better named **get\_effective\_time**, to match its description in the standard.



offset reaches some prescribed maximum. A class derived from the `tlm_gatekeeper` class can modify the control and synchronization functions, to allow different approaches to be tried.

## 9.2. Guidelines for Using TLM 2.0 Temporal Decoupling

Temporal decoupling is not for use everywhere. These guidelines may help.

1. Use temporal decoupling for models based on blocking transactions, as used for loosely timed models. There is no obvious value to temporal decoupling in non-blocking models.
2. Only apply temporal decoupling to threads that are communicating via TLM 2.0 transactions. Other SystemC protocols (for example via FIFO) have no way of communicating delays between threads (the equivalent of the delay parameter in TLM 2.0 transport functions).
3. Let the thread controlling the initiator manage the temporal decoupling and synchronization. Targets should just return the incremented delay, and avoid synchronizing if possible.
4. Allocate one quantum keeper for each thread that drives an initiator socket and is implementing temporal decoupling.
5. Ensure that the thread global quantum is always the same as the system global quantum.
6. Select a global quantum that is small enough not to swamp timing behavior of the system. For example in the SoC used in this application note, the finest time granularity that matters is the time to put a character over a 9600 baud link, approximately 1ms. A time around 10-50% of this would be a reasonable time to use as a global quantum.

## 9.3. Temporal Decoupling the Or1ksim Wrapper Class

The only thread that can be decoupled in the current model is the Or1ksim wrapper class, `Or1ksimSyncSC`, since it is the only thread with a TLM 2.0 initiator socket.

ISS are natural candidates for temporal decoupling, since they often can run large blocks of code without any need for hardware interaction. This is particularly important for modern compiling ISS (e.g ARM SystemGenerator, ARC xISS), which achieve their performance by executing thousands of instructions at a time.

The changes needed to add temporal decoupling are:

- Change the main thread, `run` so that it only tries to execute instructions up to the end of the current global quantum.
- Change the upcall transport function, `doTrans`, so that it increments the local time offset, rather than synchronizing via `wait/`
- Updates to the Or1ksim ISS library to support running to a fixed time time point.

A new class, `Or1ksimDecoupSC` is derived from `Or1ksimSyncSC` to implement the required functionality.

### 9.3.1. Adding a Function to the Or1ksim Library to Support Temporal Decoupling

One additional function is needed in the Or1ksim library to support temporal decoupling. The `or1ksim_run` already allows the user to specify a duration for which the simulation will run. A function, is added to change the duration of a run already in progress.

- ```
void or1ksim_reset_duration( double duration );
```

or1ksim_reset_duration resets the duration of a call to **or1ksim_run** which is already in progress. The argument is the duration for which the run should continue *from the current time* (i.e. not from the time of the original call to **or1ksim_run**).

This function is needed because upcalls may lead to a synchronization, increasing the time for which the ISS may run before needing resynchronization.

9.3.2. Or1ksimDecoupled Module Class Definition

The new class, **Or1ksimDecoupled** is derived from **or1ksimSyncSC**, whose header it includes. A custom constructor is defined with the same arguments as the base class constructor.

The ISS thread, **run** and the transport function, **doTrans** are both reimplemented to add temporal decoupling.

A quantum keeper for the ISS thread, **issQk** is defined.

```
tlm_utils::tlm_quantumkeeper issQk;
```

9.3.3. Or1ksimDecoupled Module Class Implementation

The constructor passes its arguments to the base class, **Or1ksimSyncSC**. The quantum keeper for the ISS thread is then initialized with the system global quantum and the local quantum calculated and local time offset zeroed with a call to **reset**.

```
tlm::tlm_global_quantum &refTgq = tlm::tlm_global_quantum::instance();
issQk.set_global_quantum( refTgq.get() );
issQk.reset();
```



Note

The global quantum accessor function, **instance** returns a reference to the global quantum. Ensure that it is assigned to a reference variable (declared as **&refTgq** here) of type **tlm::tlm_global_quantum**. Use of a plain variable would be valid code, but make a *copy* of the quantum keeper, so subsequent calls to **set** would not actually set the singleton instance. An example of the dangers of reference variables in C++ and why singleton accessors should return pointers, not references.

The main thread function, **run** is reimplemented to ensure that ISS simulation does not run past the end of the current quantum. Instead of running for ever (**or1ksim_run(-1.0);**), the ISS is run for the local time quantum, less the local time offset. This means the ISS will return exactly at the point when it should need to synchronize again.

Since the local quantum is only available through the singleton **tlm::tlm_global_quantum** a reference to that instance is obtained for use throughout this function:

```
tlm::tlm_global_quantum &refTgq = tlm::tlm_global_quantum::instance();
```

The body of the program is a perpetual loop, which calculates the time left until the next global quantum then calls the ISS for that period.

```
while( true ) {
    sc_core::sc_time timeLeft =
        refTgq.compute_local_quantum() - issQk.get_local_time();
```

On return, **or1ksim_get_time_period** is used to find out how much computation has actually been carried out and advance local time accordingly. This may be different to the duration

requested, since an upcall may set a new time point and adjusted the duration. A new time point is immediately set ready for the next loop.

```
(void)or1ksim_run( timeLeft.to_seconds());

issQk.inc( sc_core::sc_time( or1ksim_get_time_period(), sc_core::SC_SEC ));
or1ksim_set_time_point();
```

If the local time offset has reached the end of the global quantum, the thread synchronizes.

```
if( issQk.need_sync() ) {
    issQk.sync();
}
```

The transport function, **doTrans** has the same structure as the synchronous version in the base class. However instead of calling **wait** to delay calculation, it updates the local time offset. The time offset is advanced for the ISS simulation since the last time point and a new time point is set.

```
issQk.inc( sc_core::sc_time( or1ksim_get_time_period(), sc_core::SC_SEC ));
or1ksim_set_time_point();
```

The delay argument to the blocking transport is the local time offset. This may be increased by the target (to model read/write delay), and the new value becomes the local time offset on return.

```
sc_core::sc_time delay = issQk.get_local_time();
dataBus->b_transport( trans, delay );
issQk.set( delay );
```

At this point synchronization could be required—the read/write delay could have pushed the local time offset past the global quantum.

```
if( issQk.need_sync() ) {
    issQk.sync();
}
```

The duration remaining for the ISS simulation is reset in the same way as in the main thread to be the local quantum less the local time offset. On return the ISS will continue for that period.

```
tlm::tlm_global_quantum &refTgq = tlm::tlm_global_quantum::instance();
sc_core::sc_time timeLeft =
    refTgq.compute_local_quantum() - issQk.get_local_time();

or1ksim_reset_duration ( timeLeft.to_seconds() );
```

9.4. Modifying the UART to Support Temporal Decoupling

Although the threads in the UART class are not temporarily decoupled, a small modification is needed. The callback for the target socket is part of this class, and it must handle delay data for the initiator in **Or1ksimDecoupledSC** suitably.

A new class, **UartDecoupledSC**, derived from **UartSyncSC** is defined to provide a modified TLM 2.0 convenience target socket blocking callback function.

9.4.1. uartDecoupledSC Module Class Definition

The class definition includes the header of the base class and is derived from it. The constructor has the same parameters as the base class, **UartSyncSC**.

A reimplemented version of the TLM 2.0 convenience callback, `busReadWrite` is defined with the same parameters as the base class function.

9.4.2. `uartDecoupled` Module Class Implementation

The constructor just calls the base class constructor, passing on all its arguments.

The `BusReadWrite` callback has the same structure as the version in the base class. Like the base class it calls the original `UartSC` version to carry out most of the functionality.



Caution

The call is therefore to the *base class of the base class* of this class. The call cannot be to the base class, since that would call `wait`, defeating the temporal decoupling.

The difference is in updating the delay. The synchronous base class waited to model the timing delay and set the delay in the response to zero. In this version the code just increments the delay (which is the local time offset) by the additional time to carry out the read or write.

```
switch( payload.get_command() ) {  
  
    case tlm::TLM_READ_COMMAND:  
        delay += sc_core::sc_time( UART_READ_NS, sc_core::SC_NS );  
        break;
```

9.5. Main Program for Temporal Decoupling

The main program, `DecoupledSocSC.cpp` is similar in structure to the main program used for the synchronous version (see Section 8.5). This time the headers for the versions of the Or1ksim wrapper and UART implementing temporal decoupling are used and the time to use as the global quantum is defined as a parameter.

```
#include "Or1ksimDecoupledSC.h"  
#include "UartDecoupledSC.h"  
#include "TermSyncSC.h"  
  
#define QUANTUM_US 100
```

Before any modules are instantiated, the system global quantum must be set. For the initial version a value of 100µs is selected, 10% of the time taken to transmit a character at 9600 baud, so there should be no awkward timing interactions.

```
tlm::tlm_global_quantum &refTgq = tlm::tlm_global_quantum::instance();  
refTgq.set( sc_core::sc_time( QUANTUM_US, sc_core::SC_US ) );
```

Thereafter the program follows the same structure (but using the versions of the Or1ksim wrapper and UART with temporal decoupling).

9.6. Compiling and Running the Synchronous Model

Compilation is very similar to that of the synchronous model. The binaries of *all* the base classes are included when linking.

The same configuration file and OpenRISC 1000 compiled image is used to run the model with temporal decoupling.

```
$ ./DecoupledSocSC ../simple.cfg progs_or32/uart_loop
```

The results look very similar to those for the synchronized version, as shown in Figure 13.

```

$ ./SyncSocSC ../simple.cfg progs_or32/uart_loop

      SystemC 2.2.0 --- May 16 2008 10:30:46
      Copyright (c) 1996-2006 by all Contributors
      ALL RIGHTS RESERVED
      Reading script file from '../simple.cfg'...

      ... <Or1ksim initialization messages>

      Char read at      0.381741687 sec
      Read: 'F'
      Char written at   0.382841620 sec
      Char read at      0.494341667 sec
      Read: 'a'
      Char written at   0.495441600 sec
      Char read at      0.597841677 sec
      Read: 'r'
      Char written at   0.598941610 sec

      ... <Lots more output>

```

Figure 13. UART loop back program log output with temporal decoupling.

The timing reported for the first character, 'F', is 1100 μ s—in the synchronized version it was 1055 μ s. The global quantum was set to 100 μ s, which means that other threads may have a delay of up to 100 μ s before they can run, affecting the time they will report for their actions.

If the quantum is changed from 100 μ s to 10ms, the change is more dramatic, as shown in Figure 14.

```

$ ./SyncSocSC ../simple.cfg progs_or32/uart_loop

      SystemC 2.2.0 --- May 16 2008 10:30:46
      Copyright (c) 1996-2006 by all Contributors
      ALL RIGHTS RESERVED
      Reading script file from '../simple.cfg'...

      ... <Or1ksim initialization messages>

      Char read at      0.091041667 sec
      Read: 'F'
      Char written at   0.101041600 sec
      Char read at      0.101041667 sec
      Read: 'a'
      Char written at   0.111041620 sec
      Char read at      0.111041687 sec
      Read: 'r'
      Char written at   0.121041600 sec

      ... <Lots more output>

```

Figure 14. UART loop back program log output with temporal decoupling and 10ms global quantum.

The time taken to write the first character is now 9,999 μ s, completely dominated by the quantum. The typing of characters at the xterm is notably sluggish.

This is characteristic of loosely timed models with temporal decoupling. The objective is to model the gross behavior of the system with a reasonable view of the timing, such that events happen in the correct sequence. However detailed timing can be sacrificed in the interest of greater model performance.

The value for the global quantum is a subjective choice. In this case, with a busy polling UART loop back function, any delays were wasted in additional polling cycles, so a small quantum was appropriate.

In a more realistic scenario, the UART would be interrupt driven (or at least not polled continuously). Very likely the UART would only be lightly used, while other parts of the system were working. Under such circumstances, a global quantum of 100-500 μ s (10%-50% of the time to put one character on the UART) would be reasonable. The timing of characters output would be out by up to 100%, but the model would gain from fewer synchronizations.

In other scenarios an even higher quantum could be justified—for example if the UART were only for occasional diagnostic output, where sluggishness did not matter. However when modeling a 100MHz ISS as part of the SoC, the benefits of such large global quantum values would be minimal.

Beware that an excessively large quantum may break software with timing dependencies. It may mean that interrupt sequences do not arrive in a reasonable order, or flood in all at once. An example of this is shown in Section 10.

The other step to take to improve performance would be to move to an exclusively TLM 2.0 model. The SystemC buffer is a good way to model the UART to terminal connection. However by using a TLM 2.0 socket in each direction, the UART could adopt temporal decoupling, giving further performance improvement.

10. Modeling Interrupts and Running Linux on the Example SoC

The Simple SoC used in the previous sections is not sufficient to run Linux. Two significant extensions are needed.

- Memory management must be added to support Linux virtual memory. This is provided by enabling the internal MMUs (instruction and data) of the Or1ksim ISS.
- The SystemC UART peripheral must be extended to handle interrupts.

The example design was shown in Section 3.1.3, but for convenience the diagram is repeated here in Figure 15.

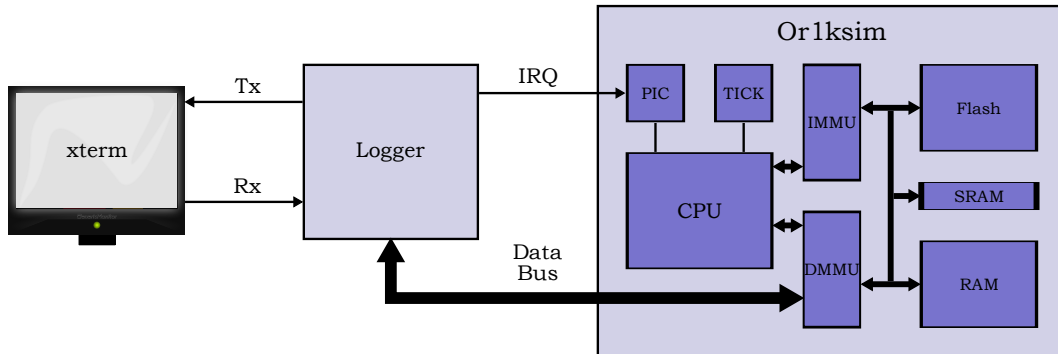

Figure 15. Simple SoC based on the OpenRISC 1000 Or1ksim with interrupts and MMU enabled.

Enabling memory management is a matter of modifying the configuration file for Or1ksim. The Linux port used here expects to boot from flash memory, so the internal memory of Or1ksim is also extended to provide this.

The UART model, `UartDecoupSC` is further extended by a new derived class, `UartIntrSC` providing a SystemC `sc_out<bool>` port through which the interrupt signal is driven.

10.1. Extending the Or1ksimDecoupSC Module Class

The Or1ksim ISS library is extended to provide an API call to generate an interrupt. The Or1ksim includes a programmable interrupt controller (PIC), which is enabled. The new API call, `or1ksim_interrupt`, takes as parameter the interrupt number to be triggered.

The Or1ksim wrapper, `Or1ksimDecoupSC` is further extended by a new derived class, `Or1ksimIntrSC`, which provides an array of signal ports to connect to external devices which wish to generate interrupts.

10.1.1. Adding an Interrupt Generation Function to the Or1ksim Library

The additional function allows the external SystemC model to call into the Or1ksim ISS to request an interrupt. The ISS requires that interrupts are not taken mid-instruction (for example while a peripheral memory access upcall is in progress), so a flag is set internally, allowing the ISS to trigger the interrupt at the start of the next instruction.

- ```
void or1ksim_interrupt(int i);
```

`void or1ksim_interrupt` requests the the interrupt given by its argument be taken at the start of the next instruction cycle.

#### 10.1.2. Or1ksimIntrSC Module Class Definition

The new module class, `Or1ksimIntrSC` is derived from the existing `Or1ksimDecoupSC` module class, whose header, `Or1ksimDecoupSC.h`, is included. The number of interrupts to be supported is given by the constant, `NUM_INTR`.

```
#define NUM_INTR 32
```

The new class derived from the base class and a custom constructor defined. The possible interrupts are represented by an array of **sc\_signal**.

```
sc_core::sc_signal<bool> intr[NUM_INTR];
```



#### Tip

It would have been possible to define an array of signal input ports, **sc\_in<bool>**. However these ports must then be explicitly connected (bound), requiring tie-off signals to be created in the main program.

By creating actual signals, interrupts that are unused can be left unbound and ignored.

A SystemC method is required to handle the interrupts (since it never waits, a thread is not needed). This can respond to interrupts in parallel with the main ISS execution thread.

```
void intrMethod();
```

### 10.1.3. or1ksimIntrSC Module Class Implementation

The constructor passes its arguments to the base class constructor for processing. It then sets up **intrMethod** as a SystemC method process, sensitive to the positive edge of each interrupt signal. There is no need to initialize this function.

```
SC_METHOD(intrMethod);
for(i = 0 ; i < NUM_INTR ; i++) {
 sensitive << intr[i].posedge_event();
}
dont_initialize();
```

The interrupt method is triggered by a positive edge on one of the signals. It loops through to find which interrupt was triggered and generates a call to **or1ksim\_interrupt** for that interrupt number. In principle more than one could be triggered in the same cycle, so all are checked.

```
for(i = 0 ; i < NUM_INTR ; i++) {
 if(intr[i].event()) {
 or1ksim_interrupt(i);
 }
}
```

## 10.2. Extending the UartDecoupSC Module Class

The existing UART module processes interrupts, but does not generate an external interrupt signal. To generate an interrupt signal, **UartDecoupSC** is further extended by a new derived class, **UartIntrSC**, which provides a signal port and a new thread to drive that signal port

An extra thread is required, because both the **rxMethod** and **busThread** processes may wish to drive signals, but SystemC requires that a signal is driven by a single process. Just as in hardware design a simple wire would not normally have more than one driver.

The new process communicates with the existing processes via a FIFO internal to the UART, allowing **rxMethod** and **busThread** to both request interrupt activity and for those requests to be processed in the order they were generated.

### 10.2.1. UartIntrSC Module Class Definition

The new module class, **UartIntrSC** is derived from the existing **UartDecoupSC** module class, whose header, **UartDecoupSC.h**, is included.



A custom constructor is declared, and a signal output port, `sc_out<bool> intr` through which the interrupt will be driven.

The new thread, `intrThread` is declared. It will use re-implemented versions of the `genIntrr` and `clrIntr` functions from the base class, `UartSC`.

A Boolean FIFO is used to hold the queue of requests from the existing processes, `rxMethod` and `busThread`.

```
sc_core::sc_fifo<bool> intrQueue;
```

### 10.2.2. UartIntrSC Module Class Implementation

Since this class declares a new SystemC process, `SC_HAS_PROCESS` is used. The constructor passes its arguments to the base class, `UartDecoupledSC` and sets the FIFO queue size to 1.

```
UartIntrSC::UartIntrSC(sc_core::sc_module_name name,
 unsigned long int _clockRate,
 bool _isLittleEndian) :
 UartDecoupledSC(name, _clockRate, _isLittleEndian),
 intrQueue(1)
{
```



#### Note

The choice of FIFO size means that there should be only one request for interrupt pending. In principle this could block an attempt by the `rxMethod` to write to the FIFO, and since SystemC methods may not wait (unlike threads) a run time error will occur.

This is an explicit model design decision. If there is interrupt congestion, then it would be useful to know—indicating design issues over the UART capacity. If this were not an issue, then it would be quite valid to use a larger FIFO capacity.

The constructor then creates the new SystemC method for `intrThread`.

`intrThread` has a very simple API. If `true` is read it asserts an interrupt (drives the interrupt port `true`), otherwise it deasserts the interrupt port (drives the interrupt port `false`).

On initialization, the interrupt port is deasserted (`false`). The thread then sits in a perpetual loop, copying requests from the FIFO to the interrupt signal output port.

```
while(true) {
 intr.write(intrQueue.read());
}
```

The interrupt generator, `genIntr` is almost identical to the version in the base class, `UartSC`. The only difference is that if an interrupt is generated, a request to drive the signal is written onto the internal interrupt FIFO for processing by the `intrThread` thread.

```
setIntrFlags(); // Show highest priority
intrQueue.write(true); // Request an interrupt signal
```

The interrupt clear routing is a similar modification, this time requesting the interrupt signal to be cleared by writing `false` on the FIFO queue.

```
if(isSet(regs.iir, UART_IIR_IPEND)) { // 1 = not pending
 intrQueue.write(false); // Deassert if none left
```

### 10.3. Main Program for the Interrupt Driven Model

The main program for the model supporting interrupts is in `intrSocSC.cpp`. It has a very similar structure to the main program used with the temporal decoupling example in Section 9.5,

but uses the new versions of the Or1ksim wrapper class and UART module, `Or1ksimIntrSC` and `UartIntrSC`.

A baud rate of 115,200 is expected for the Linux kernel serial port and a global quantum of 10 $\mu$ s is appropriate for this. A constant is defined to hold the interrupt port number used by the UART (2).

```
#define BAUD_RATE 115200
#define QUANTUM_US 10

#define INTR_UART 2
```

The main program structure is unchanged, except that the UART interrupt output port needs to be connected to the correct signal in the Or1ksim wrapper:

```
uart.intr(iss.intr[INTR_UART]);
```

#### 10.4. Running the Interrupt Driven Model

Compilation and linking of the program follows the same procedure as previous examples.

As a simple test, the interrupt loop program used in earlier examples is extended to demonstrate basic interrupt handling. However the main test is booting a Linux kernel.

##### 10.4.1. Simple Test for the Interrupt Driven SoC Model

A simple test is provided in `uart_loop_intr.c` as an extension of `uart_loop.c`. After a character is read, the program loops to wait until the interrupt pending flag is clear (indicating the transmit buffer is empty).

```
do { /* Wait for interrupts to clear */
;
} while(is_set(uart->iir, UART_IIR_IPEND));
```

This is a very basic test—if all is well it behaves identically to the existing loop program. If there is a problem clearing the transmit buffer empty interrupt, or the received data available interrupt is not cleared when data is read, then the program will lock up waiting for the interrupt pending flag to clear.

##### 10.4.2. Running Linux

This test uses a Linux 2.6.19 kernel built for the standalone Or1ksim as described in Embecosm Application Note 2. The OpenCores OpenRISC 1000 Simulator and Tool Chain: Installation Guide. [2]. A configuration file, which enables the internal memory management units (MMUs) and Programmable Interrupt Controller (PIC) of the Or1ksim is provided, `linux.cfg`. This also declares additional internal memory space in Or1ksim for flash and SRAM.

The SystemC model is then run with this configuration file and the Linux kernel binary.

```
./IntrSocSC linux.cfg ../linux-2.6.19/vmlinux
```

Initially Linux copies itself from flash memory to RAM.

```
Copying Linux... Ok, booting the kernel.
```

After a pause while initial booting is taking place the serial interface is ready, allowing the normal kernel boot messages to appear:

```
Linux version 2.6.19-or32 (jeremy@thomas) (gcc version 3.4.4) #59 Wed Jun 25 18:
48:06 BST 2008
Detecting Processor units:
Signed 0x391
```

```

Setting up paging and PTEs.
write protecting ro sections (0xc0002000 - 0xc024c000)
Setting up identical mapping (0x80000000 - 0x90000000)
Setting up identical mapping (0x92000000 - 0x92002000)
Setting up identical mapping (0xb8070000 - 0xb8072000)
Setting up identical mapping (0x97000000 - 0x97002000)
Setting up identical mapping (0x99000000 - 0x9a000000)
Setting up identical mapping (0x93000000 - 0x93002000)
Setting up identical mapping (0xa6000000 - 0xa6100000)
Setting up identical mapping (0x1e50000 - 0x1fa0000)
dtlb_miss_handler c00040c8
itlb_miss_handler c00041a8
Built 1 zonelists. Total pages: 3953
Kernel command line: root=/dev/ram console=ttyS0

<Lots more Linux kernel messages...>

Serial: 8250/16550 driver $Revision: 1.90 $ 4 ports, IRQ sharing disabled
serial8250.0: ttyS0 at MMIO 0x90000000 (irq = 2) is a 16450

<Lots more Linux kernel messages...>

VFS: Mounted root (ext2 filesystem) readonly.
Freeing unused kernel memory: 104k freed
init started: BusyBox v1.4.1 (2007-03-22 18:53:56 EST) multi-call binary
init started: BusyBox v1.4.1 (2007-03-22 18:53:56 EST) multi-call binary
Starting pid 22, console /dev/ttyS0: '/etc/init.d/rcS'

Please press Enter to activate this console.

```

This takes a simulated time of about 37 seconds, and on a modern PC an elapsed time of around 20-25 seconds (the Or1ksim ISS in this minimal configuration runs at 150-200MHz<sup>14</sup>).

At this point hitting return will start up a Linux shell, running some basic commands and in this example the BusyBox utilities (see the website for more details).

```

Please press Enter to activate this console.
Starting pid 25, console /dev/ttyS0: '/bin/sh'

BusyBox v1.4.1 (2007-03-22 18:53:56 EST) Built-in shell (ash)
Enter 'help' for a list of built-in commands.

ls /proc
1 2 bus iomem self
10 25 cmdline ioports slabinfo
11 26 cpuinfo kcore stat
12 3 crypto kmsg sys
13 4 devices loadavg sysrq-trigger
14 5 diskstats locks sysvipc
15 6 driver meminfo tty

```

<sup>14</sup> This may seem exceptionally fast for an interpreting ISS, but this model is configured with slow RAM with a 20-25 cycle access time and no caches. So 150-200MHz represents only 5-10 MIPS. That's why booting a basic Linux kernel takes 37s of simulated time, rather than the 2-3s that might reasonably be expected!

```
16 7 execdomains misc uptime
17 8 filesystems mounts version
18 9 fs net vmstat
19 buddyinfo interrupts partitions zoneinfo
busybox mount
rootfs on / type rootfs (rw)
/dev/root on / type ext2 (ro)
proc on /proc type proc (rw)
#
```

The importance of choosing a suitable value for the global quantum is well illustrated here. Rebuild the model with a global quantum of 100 $\mu$ s—rather longer than the time it takes to transmit one character at 115,200 baud.

```
#define QUANTUM_US 100
```

The time taken to boot is marginally faster (19s), but this time the terminal cannot cope with the erratic interrupt behavior.

```
VFS: Mounted root (ext2 filesystem) readonly.
Freeing unused kernel memory: 104k freed
init started: BusyBox v1.4.
Please press Ent
```

The Linux serial driver loses interrupts and the system locks up and will eventually crash with an unhandled interrupt exception.



## A. Downloading the Example Models

The example models used in this application note may all be downloaded from the Embecosm website, [www.embecosm.com](http://www.embecosm.com). They are licensed under the GNU Lesser General Public License so are freely available to be used and incorporated in other programs.

The main directory of the distribution contains:

- A directory, **sysc\_models**, containing the example SystemC models;
- A patch file to adapt the Or1ksim ISS as described in this application note;
- Configuration files for use with Or1ksim when running the simple models and the Linux kernel; and
- A copy of the GNU Lesser General Public License

Within the **sysc\_models** directory a further directory, **progs\_or32**, contains the example programs which run on the Or1ksim ISS. They are provided as both source and compiled binary, so that the OpenRISC 1000 tool chain need not be installed to run the models.

### A.1. Patching Or1ksim

The instructions for building standard Or1ksim may be found in Embecosm Application Note 2. The OpenCores OpenRISC 1000 Simulator and Tool Chain: Installation Guide. [2] on the Embecosm website. This includes some patches to the standard distribution to fix a number of known bugs. The ISS uses standard GNU configuration and build.

The changes required to Or1ksim are provided as a patch file. To use this download and unpack standard Or1ksim has in directory **or1ksim-0.2.0**. Apply the Embecosm bug fix patches described above and documented in Embecosm Application Note 2. The OpenCores OpenRISC 1000 Simulator and Tool Chain: Installation Guide. [2]. This is the source for a working *standard* Or1ksim ISS.

Change to the **or1ksim-0.2.0** directory. Assuming the Embecosm patches for this application note are in **embecosm\_patch\_or1ksim\_an1.bz2**, they can be applied by the command:

```
bzcat -dc ../embecosm_patch_or1ksim_an1.bz2 | patch -p1
```

The Or1ksim ISS can then be built from this patched source in exactly the same way as the standard ISS.

### A.2. Building the Linux Kernel

The Linux kernel is built as described in Embecosm Application Note 2. The OpenCores OpenRISC 1000 Simulator and Tool Chain: Installation Guide. [2]. This does require building the Or1ksim tool chain. This includes patches to the Linux kernel required to get it to work correctly on the Or1ksim ISS

## Glossary

### 2-state

Hardware logic model which is based only on logic high and logic low (binary 0 and binary 1) values.

See also: 4-state.

### 4-state

Hardware logic model which considers unknown (**X**) and unproven (**Z**) values as well as logic high and logic low (binary 0 and binary 1).

See also: 2-state.

### Application Binary Interface

The low-level interface between an application program and the operating system, thus ensuring binary compatibility between programs.

C++ notoriously suffers from lack of agreed standards in this area.

### approximately timed

In TLM 2.0 a modeling style where timing information is provided at the level of transactions representing the phases of data transfer in a specific bus protocol (for example the address and data phases of an AHB read or write).

See also: loosely timed, phase.

### backward transport path

In TLM 2.0 non-blocking transport, the transport function which returns the response transaction from target to initiator.

See also: transport function, forward transport path.

### base class

In object oriented programming a class from which other classes (the derived classes) are derived, inheriting variables and functions. Specifically a term favored by C++, also referred to as a parent class or super-class.

See also: derived class.

### big endian

A description of the relationship between byte and word addressing on a computer architecture. In a big endian architecture, the least significant byte in a data word resides at the highest byte address (of the bytes in the word) in memory.

The alternative is little endian addressing.

See also: little endian.

### blocking

Within the context of TLM, a transaction which blocks the flow of control in the initiator until the target has completed the transaction request and responded.

See also: non-blocking.

### convenience socket

A TLM 2.0 wrapper, providing for simple TLM communication based on C++ callbacks.

#### derived class

In object oriented programming a class which has inheriting variables and functions from another class (known as the base class). Specifically a term favored by C++, also referred to as a child class or sub-class.

See also: base class.

#### direct memory interface

In hardware and software design communication between memory and a peripheral without the constant intervention of the processor.

In TLM 2.0 communication between two threads (typically representing a processor and a memory block) by direct writing through a pointer to the memory rather than by a transactional exchange.

See also: transport function, backward transport path.

#### forward transport path

In TLM 2.0 non-blocking transport the transport function, which passes the opening transaction from initiator to target.

See also: transport function, backward transport path.

#### Generic Payload

Within TLM 2.0, a class suitable for use as payload for transactions. Recommended to maximize the interoperability of TLMs.

See also: payload.

#### Hardware Description Language (HDL)

A language (Verilog and VHDL are the best known), which describes hardware. Can be used to describe both an actual chip and its test bench.

#### initiator

The initiator of a transactional exchange to a target. In TLM 2.0 an initiator module must implement an initiator socket of the appropriate type (blocking or non-blocking).

See also: target.

#### Instruction Set Simulator (ISS)

A software model of a CPU core instruction set. Typically completely models the instruction semantics, but not the full microarchitecture of a particular CPU implementation. Timing information may be just an instruction count, or may (as with the Or1ksim) offer some estimate of timing delays due to memory accesses, caching and virtual memory access.

#### little endian

A description of the relationship between byte and word addressing on a computer architecture. In a little endian architecture, the least significant byte in a data word resides at the lowest byte address (of the bytes in the word) in memory.

The alternative is big endian addressing.

See also: big endian.

#### loosely timed

In TLM 2.0 a modeling style, where timing information is provided at the level of transactions representing a complete data transfer across a hardware bus.

See also: approximately timed.

#### memory management unit (MMU)

A hardware component which maps virtual address references to physical memory addresses via a page lookup table. An exception handler may be required to bring non-existent memory pages into physical memory from backing storage when accessed.

On a Harvard architecture (i.e. with separate logical instruction and data address spaces), two MMUs are typically needed.

#### non-blocking

Within the context of TLM, a transaction which allows the flow of control in the initiator to continue immediately the transaction is sent. The response will be provided later by a transport call from the target back to the initiator..

See also: blocking.

#### OSCI

See Open SystemC Initiative.

#### passthrough

A term describing a TLM 2.0 convenience socket which does not perform an automatic conversion between blocking and non-blocking transport. Potentially more efficient than the other types of convenience socket.

See also: payload.

#### payload

The data passed between threads by a transaction.

See also: Generic Payload.

#### phase

In TLM 2.0 approximately timed modeling, a transaction exchange representing a single phase of the specific bus protocol being modeled (for example the address phase of an AHB read or write).

See also: approximately timed.

#### POSIX

An IEEE standard for application programming interfaces and utilities for Unix/Linux operating systems.

#### programmable interrupt controller (PIC)

A hardware component which provides a large number of interrupt ports, which are mapped onto one or two interrupt ports on an actual processor. The PIC will provide a lookup table of interrupt service functions for its interrupts, which the interrupt service function on the processor can use to identify the correct handler to use.

#### quantum

In TLM 2.0 with temporal decoupling, the maximum time a thread may run ahead of the main system clock. This may be regulated by a quantum keeper.

See also: temporal decoupling, quantum keeper.

#### quantum keeper

In TLM 2.0 with temporal decoupling, an object which enforces the rule that threads may not run more than the quantum ahead of the main system clock



See also: temporal decoupling, quantum.

#### singleton

In object oriented programming, a class which can have at most one instance. Typically implemented by making the constructor private and providing an access function which instantiates the class on its first call and on all other calls returns a pointer to that instance.

#### socket

Within the context of TLM 2.0, a SystemC port and export combined with the associated interfaces for blocking and non-blocking transport, direct memory access and debug.

See also: SystemC.

#### System on Chip (SoC)

A silicon chip which includes one or more processor cores.

#### SystemC

A set of libraries and macros, which extend the C++ programming language to facilitate modeling of hardware.

Standardized by the *Open SystemC Initiative*, who provide an open source reference implementation.

See also: Open SystemC Initiative.

#### tagged socket

A TLM 2.0 convenience socket, which incorporates a numerical *tag* to identify the socket in use. This allows a single callback function to handle multiple sockets, with the tag identifying the socket which caused the callback to be invoked.

See also: socket.

#### target

The responder to a transactional exchange initiated by an initiator. In TLM 2.0 a target module must implement a target socket of the appropriate type (blocking or non-blocking).

See also: initiator.

#### temporal decoupling

In TLM 2.0 the concept of allowing individual threads to run ahead of the main simulation time stamp. The maximum permitted time of run ahead is known as the *quantum* and may be regulated by a quantum keeper.

See also: quantum, quantum keeper.

#### thread

In software, a logical parallel flow of control. In the context of SystemC, the main function of such a thread can be specified with the **SC\_THREAD** macro. In SystemC a **SC\_THREAD** is distinguished from a **SC\_METHOD** because it can suspend execution with **wait** calls.

See also: SystemC.

#### TLM

An abbreviation for (depending on context) *Transaction Level Model* or *Transaction Level Modeling*.

See also: Transaction Level Model, Transaction Level Modeling.

## TLM 2.0

The OSCI standard interface for writing *Transaction Level Models* in SystemC.  
See also: Transaction Level Model, SystemC.

## transaction

In TLM modeling the exchange of data between two threads.

## Transaction

An exchange of data (the payload) between two parallel processes. In TLM 2.0 this transaction occurs through SystemC ports implementing the TLM 2.0 interfaces, which are known as sockets.

A full description is provided in Section 2.2.

See also: payload, socket.

## Transaction Level Model

A software model in which the components of the model communicate by transferring information to and from each other (transactions).

A full description is provided in Section 2.2.

## Transaction Level Modeling

The process of writing software models using *Transaction Level Model*

See also: Transaction Level Model.

## transport function

The C++ function which transfers data from an initiator to a target, and (for a non-blocking interface), the response back from the target to the initiator. Within the context of TLM 2.0 blocking and non-blocking transport interfaces are defined.

See also: SystemC.

## References

- [1] A loosely coupled parallel LISP execution system. John ffitch. International Specialist Seminar on the Design and Application of Parallel Digital Processors, 11-15 Apr 1988. pp 128-133.
- [2] Embecosm Application Note 2. The OpenCores OpenRISC 1000 Simulator and Tool Chain: Installation Guide. Embecosm Limited, June 2008.
- [3] IEEE Standard SystemC Language Reference Manual. IEEE Computer Society, 1666-2005, 31 March, 2006.
- [4] OSCI TLM 2.0 User Manual. Open SystemC Initiative, June, 2008.
- [5] SystemC Version 2.0 User Guide. Open SystemC Initiative, 2002.