

c-Bottlenecks in Serial Production Lines: Identification and Application

S.-Y. CHIANG^a, C.-T. KUO^b and S.M. MEERKOV^{c,*}

^a*Department of Computer Communication Engineering, Ming-Chuan University, Taoyuan County, Taiwan, R.O.C.*; ^b*Deceased*; ^c*Department of Electrical Engineering and Computer Science, University of Michigan, Ann Arbor, MI 48109-2122, USA*

(Received 15 February 2001)

The bottleneck of a production line is a machine that impedes the system performance in the strongest manner. In production lines with the so-called Markovian model of machine reliability, bottlenecks with respect to the downtime, uptime, and the cycle time of the machines can be introduced. The two former have been addressed in recent publications [1] and [2]. The latter is investigated in this paper. Specifically, using a novel aggregation procedure for performance analysis of production lines with Markovian machines having different cycle time, we develop a method for c-bottleneck identification and apply it in a case study to a camshaft production line at an automotive engine plant.

Keywords: Production lines; Markovian models; Bottleneck identification.

1. INTRODUCTION

Serial production lines are sets of machines and buffers arranged in the consecutive order as shown in Figure 1.1, where the circles represent the machines and the rectangles are the buffers. In practice, the machines are not absolutely reliable and experience random breakdowns. This leads to a reduction of the system production rate (*PR*), which is the number of parts produced, on the average, by the last machine per unit of time. Often, this reduction is quite substantial: performance at the level of 60–70% of system capacity (*i.e.*, when no

* Corresponding author. Tel.: +1 (734) 763-6349, Fax: +1 (734) 763-8041, E-mail: smm@eecs.umich.edu.

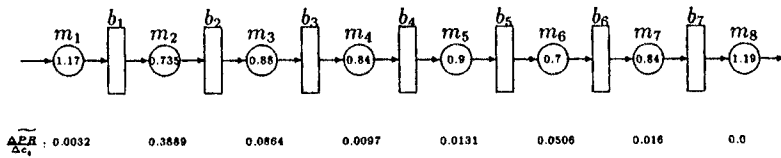

FIGURE 1.1 Example of serial production line.

breakdowns take place) is quite typical for machining operations in many large volume production systems. Therefore, identification of a machine, which is most responsible for these losses, is an important problem of production lines management and control. Such a machine is typically referred to as the bottleneck (BN).

Often, a machine is viewed as the BN if it is the slowest in the system [3, 4]. Unfortunately, this is not necessarily true: Figure 1.1 presents an example where machine m_6 is the slowest (as measured by its production rate in isolation indicated in the circle), whereas the one that has the largest effect on the PR is machine m_2 (as measured by the sensitivity of the PR with respect to the speed of each machine, indicated under each machine—see Section 3 for details of this calculation). Therefore, one needs rigorous methods for BN identification. For production systems with the so-called Bernoulli model of machine reliability such a method has been developed in [5]. Several applications have been reported in [6–8]. Although typical for assembly operations, the Bernoulli model is not directly applicable to machining systems where the downtime is, on the average, much longer than the cycle. In this situation, Markovian model, [9–15], is more appropriate. In this paper we consider production lines with Markovian machines.

BNs in serial production lines with Markovian machines have been analyzed in [1] and [2]. The research was based on the assumption that all machines have identical cycle time. Although this assumption does hold in many production systems, it is not universally the case. Therefore, development of a method for BN identification in Markovian production lines with machines having different cycle time is an important problem. This paper is devoted to this topic.

Specifically, in Section 2 below, we define the model of the production line under consideration and introduce the notion of c-BN. Section 3 presents a recursive aggregation procedure for performance evaluation in serial production lines with Markovian machines having

different cycle time and proves its convergence. Although other approximation procedures for such lines do exist in the literature, [12–15], none is proven to converge and, in our experience, do have problems with convergence (when the cycle times of the machines are substantially different). Based on this aggregation procedure, Section 4 presents a c-BN identification tool. Section 5 applies this tool to a case study at an automotive engine plant, and Section 6 formulates the conclusion. The proof of convergence is given in the Appendix.

2. PROBLEM FORMULATION

The following model of a serial production line is considered throughout this work:

- (i) The system consists of M machines arranged serially and $M - 1$ buffers separating each consecutive pair of machines.
- (ii) Each machine m_i has two states: up and down. When up, the machine is capable of producing with the rate c_i parts per unit of time (*i.e.*, cycle time is $1/c_i$); when the machine is down, no production takes place.
- (iii) The uptime and the downtime of each machine m_i are random variables distributed exponentially with parameters p_i , and r_i , respectively.
- (iv) Each buffer b_i is characterized by its capacity, $N_i < \infty$, $1 \leq i \leq M - 1$.
- (v) Machine m_i is starved at time t if buffer b_{i-1} is empty and m_{i-1} fails to put a part into b_{i-1} at time t ; machine m_1 is never starved.
- (vi) Machine m_i is blocked at time t if buffer b_i is full and m_{i+1} fails to take a part from b_i at time t ; machine m_M is never blocked.

A production line defined by (i)–(vi) is denoted as $\{p_1, r_1, c_1, \dots, p_M, r_M, c_M; N_1, \dots, N_{M-1}\}$.

Remark 2.1 Due to assumption (iii), the average up- and downtime of the machines are:

$$T_{\text{up}_i} = \frac{1}{p_i}; \quad T_{\text{down}_i} = \frac{1}{r_i}, \quad i = 1, \dots, M.$$

Therefore, the so-called efficiency of each machine is

$$e_i = \frac{T_{\text{up}_i}}{T_{\text{up}_i} + T_{\text{down}_i}} = \frac{1}{1 + (T_{\text{down}_i}/T_{\text{up}_i})}, \quad i = 1, \dots, M,$$

and the production rate of each machine in isolation, indicated in the circles of Figure 1.1 and all subsequent figures, is defined as

$$PR_{\text{iso}} = e_i c_i, \quad i = 1, \dots, M. \quad (2.1)$$

Production rate of the line $\{p_1, r_1, c_1, \dots, p_M, r_M, c_M; N_1, \dots, N_{M-1}\}$ is the average number of parts produced by the last machine, m_M , per unit of time. Given model (i)-(vi), the production rate, \widetilde{PR} , is a function of all the machine and buffer parameters:

$$\widetilde{PR} = \widetilde{PR}(p_1, r_1, c_1, p_2, r_2, c_2, \dots, p_M, r_M, c_M; N_1, \dots, N_{M-1}). \quad (2.2)$$

We use this function to define the c-bottlenecks.

DEFINITION 2.1 *Machine m_i is the c-BN if*

$$\frac{\partial \widetilde{PR}}{\partial c_i} > \frac{\partial \widetilde{PR}}{\partial c_j} \quad \forall j \neq i.$$

Remark 2.2 Throughout this paper, the symbols with the “~” denote the exact values of the appropriate quantity. The respective analytical approximation, to be introduced below, is denoted by the same symbol but without the “~”

Unfortunately, direct identification of c-BN using this definition is impossible. The reason is two fold: First, the derivatives of \widetilde{PR} cannot be measured on the factory floor during the normal system operation. Second, in most cases they cannot be calculated analytically as well since even the calculation of \widetilde{PR} itself for systems with more than two machines is impossible, let alone the calculation of its derivatives. Therefore, the identification method has to be an

indirect one. More specifically, we are seeking a c-BN identification tool that is based either on the data available on the factory floor through real time measurement (such as average up- and down-time, starvation and blockage time, etc.) or on the data that can be constructively calculated using the machine and buffer parameters (r_i, p_i, c_i , and N_i). We refer to this tool as the **c-Bottleneck Indicator**. The problem, then, addressed in this work is: *Given a production systems defined by (i)–(vi), derive an Indicator for c-BN identification.*

3. PERFORMANCE EVALUATION

3.1. Performance Measures

Performance measures of interest in this work are the system production rate and the probabilities of machine manufacturing starvation and blockage. The former is defined in Section 2 (see the text above expression (2.2)). The latter are defined as:

$$\begin{aligned}\widetilde{ms}_i &= \text{Prob}\left(\{m_{i-1} \text{ fails to put parts into } b_{i-1} \text{ at time } t\} \right. \\ &\quad \cap \{b_{i-1} \text{ is empty at time } t\} \\ &\quad \left. \cap \{m_i \text{ is up at time } t\}\right), \\ \widetilde{mb}_i &= \text{Prob}\left(\{m_i \text{ is up at time } t\} \right. \\ &\quad \cap \{b_i \text{ is full at time } t\} \\ &\quad \left. \cap \{m_{i+1} \text{ fails to take parts from } b_i \text{ at time } t\}\right).\end{aligned}$$

These probabilities are functions of the machine and buffer parameters:

$$\begin{aligned}\widetilde{ms}_i &= \widetilde{ms}_i(p_1, r_1, c_1, p_2, r_2, c_2, \dots, p_M, r_M, c_M; N_1, \dots, N_{M-1}), \\ \widetilde{mb}_i &= \widetilde{mb}_i(p_1, r_1, c_1, p_2, r_2, c_2, \dots, p_M, r_M, c_M; N_1, \dots, N_{M-1}).\end{aligned}$$

In addition to the probabilities of manufacturing starvation and blockage, we would need the probabilities of the so-called communication starvation and blockage. The latter are defined in terms of the former as follows:

$$\begin{aligned} \tilde{c}s_i &= \frac{\tilde{m}s_i}{e_i}, \quad i = 1, \dots, M, \\ \tilde{c}b_i &= \frac{\tilde{m}b_i}{e_i}, \quad i = 1, \dots, M. \end{aligned} \tag{3.1}$$

A recursive procedure for estimating these performance measures is given next.

3.2. Recursive Procedure and Performance Measures Estimates

To introduce a method for performance analysis, developed in this work, consider a two-machine line defined by assumptions (i)–(vi). It was shown in [16] that its production rate can be calculated as follows:

If $c_1 < c_2$, then

$$\tilde{P}R = \frac{c_2 e_2 A e^{k_1 N_1} + c_1 e_1 B e^{k_2 N_1} + c_1 e_1 C e^{-k_2 N_1}}{A e^{k_1 N_1} + B e^{k_2 N_1} + C e^{-k_2 N_1}}, \tag{3.2}$$

where

$$e_1 = \frac{r_1}{r_1 + p_1}, \quad e_2 = \frac{r_2}{r_2 + p_2},$$

$$R = \sqrt{\left[c_1(r_1 + r_2 + p_2) - c_2(r_1 + r_2 + p_1) \right]^2 + 4c_1 c_2 p_1 p_2},$$

$$k_1 = \frac{r_1 c_1^2 (r_1 + r_2 + p_2) - c_1 c_2 \left[(r_1 + r_2)^2 + (r_1 + r_2)(p_1 + p_2) + (r_1 p_2 + r_2 p_1) \right] + r_2 c_2^2 (r_1 + r_2 + p_1)}{2c_1 c_2 (r_1 + r_2)(c_1 - c_2)},$$

$$k_2 = \frac{(c_1 r_1 + c_2 r_2) R}{2c_1 c_2 (r_1 + r_2)(c_2 - c_1)},$$

$$A = r_1 R^2 + r_1 R \left[c_1(r_1 + r_2 + p_2) - c_2(r_1 + r_2 + p_1) \right],$$

$$B = r_2 p_1 c_2 \left[(c_1 - c_2)(r_1 - r_2) - (c_2 p_1 + c_1 p_2) - R \right],$$

$$C = \frac{e_2(c_2 - c_1 e_1)A + c_1 e_1(1 - e_2)B}{c_1 e_1(e_2 - 1)}.$$

If $c_1 > c_2$, then

$$\widetilde{PR} = \frac{c_1 e_1 A e^{k_1 N_1} + c_2 e_2 B e^{k_2 N_1} + c_2 e_2 C e^{-k_2 N_1}}{A e^{k_1 N_1} + B e^{k_2 N_1} + C e^{-k_2 N_1}}, \tag{3.3}$$

where

$$e_1 = \frac{r_1}{r_1 + p_1}, \quad e_2 = \frac{r_2}{r_2 + p_2},$$

$$R = \sqrt{\left[c_1(r_1 + r_2 + p_2) - c_2(r_1 + r_2 + p_1) \right]^2 + 4c_1 c_2 p_1 p_2},$$

$$k_1 = \frac{r_1 c_1^2 (r_1 + r_2 + p_2) - c_1 c_2 \left[(r_1 + r_2)^2 + (r_1 + r_2)(p_1 + p_2) + (r_1 p_2 + r_2 p_1) \right] + r_2 c_2^2 (r_1 + r_2 + p_1)}{2c_1 c_2 (r_1 + r_2)(c_2 - c_1)},$$

$$k_2 = \frac{(c_1 r_1 + c_2 r_2)R}{2c_1 c_2 (r_1 + r_2)(c_2 - c_1)},$$

$$A = r_1 R^2 + r_1 R \left[c_1(r_1 + r_2 + p_2) - c_2(r_1 + r_2 + p_1) \right],$$

$$B = r_1 p_2 c_1 \left[(c_1 - c_2)(r_1 - r_2) - (c_2 p_1 + c_1 p_2) + R \right],$$

$$C = \frac{e_1(c_1 - c_2 e_2)A + c_2 e_2(1 - e_1)B}{c_2 e_2(e_1 - 1)}.$$

If $c_1 = c_2 = c$, then

$$\widetilde{PR} = \begin{cases} \frac{r_1 r_2}{(p_1 + r_1)(p_2 + r_2)} \\ \times \left[\frac{p_1(p_2 + r_2) - p_2(p_1 + r_1)e^{-\beta N_1}}{p_1 r_2 - p_2 r_1 e^{-\beta N_1}} \right] c, & \frac{p_1}{r_1} \neq \frac{p_2}{r_2}, \\ \frac{c r_2^2 (r_1 + r_2) + N_1 r_1 r_2 (p_2 + r_2)^2}{(p_2 + r_2)^2 \left[c(r_1 + r_2) + N_1 r_1 (p_2 + r_2) \right]} c, & \frac{p_1}{r_1} = \frac{p_2}{r_2}, \end{cases} \tag{3.4}$$

where

$$\beta = \frac{(r_1 + r_2 + p_1 + p_2)(p_1 r_2 - p_2 r_1)}{(r_1 + r_2)(p_1 + p_2)c}.$$

Using these expressions, we introduce a recursive procedure for performance analysis of Markovian production lines with arbitrary number of machines. This procedure iterates the values of p_i , r_i , c_i , and N_i to produce a sequence of numbers $cb_i(s)$, $cs_i(s)$, $c_i^b(s)$ and $c_i^f(s)$, $s = 0, 1, 2, \dots$, according to the following rule:

$$\begin{aligned} cb_i(s+1) &= \frac{[e_i c_i^f(s) - \widetilde{PR}(p_i, r_i, c_i^f(s), p_{i+1}, r_{i+1}, c_{i+1}^b(s+1), N_i)]}{e_i c_i^f(s)}, \\ &1 \leq i \leq M-1, \\ c_i^b(s+1) &= c_i [1 - cb_i(s+1)], \quad 1 \leq i \leq M-1, \\ cs_i(s+1) &= \frac{[e_i c_i^b(s+1) - \widetilde{PR}(p_{i-1}, r_{i-1}, c_{i-1}^f(s+1), p_i, r_i, c_i^b(s+1), N_{i-1})]}{e_i c_i^b(s+1)}, \\ &2 \leq i \leq M, \\ c_i^f(s+1) &= c_i [1 - cs_i(s+1)], \quad 2 \leq i \leq M, \end{aligned} \tag{3.5}$$

with boundary conditions

$$c_1^f(s) = c_1, \quad c_M^b(s) = c_M, \quad s = 0, 1, 2, \dots$$

and initial conditions

$$c_i^f(0) = c_i, \quad i = 2, \dots, M-1,$$

where $\widetilde{PR}(p_1, r_1, c_1, p_2, r_2, c_2, N_1)$ is calculated according (3.2), (3.3) and (3.4), whichever case is applicable.

There are two principal components of this procedure: backward and forward aggregation (denoted by superscripts b and f , respectively). In the backward aggregation, the last two machines, m_M and m_{M-1} are aggregated into a single machine m_{M-1}^b , defined by parameters p_{M-1}, r_{M-1} and c_{M-1}^b obtained using cb_{M-1} . Then machine m_{M-1}^b is aggregated with m_{M-2} to result in m_{M-2}^b , defined by $p_{M-2}, r_{M-2}, c_{M-2}^b$, and so on until all machines are aggregated into m_1^b . In the forward aggregation, the first machine m_1 is aggregated with m_2^b to produce m_2^f with parameters p_2, r_2 and c_2^f , obtained using cs_2 . Then m_2^f is aggregated with m_3^b to result in m_3^f , and so on until all machines are aggregated into m_M^f . Then the process is repeated again. Note that, unlike [12–15] where p_i, r_i , and c_i are iterated, recursive procedure (3.5) iterates only machine parameters c_i . This is why the proof of its convergence becomes possible.

The question of convergence of the resulting sequences $cb_i(s), cs_i(s), c_i^b(s)$ and $c_i^f(s), s = 0, 1, \dots$, is answered in the following:

THEOREM 3.1 *Recursive procedure (3.5) is convergent and, therefore, the following limits exist:*

$$\begin{aligned} \lim_{s \rightarrow \infty} cb_i(s) &=: cb_i, & \lim_{s \rightarrow \infty} cs_i(s) &=: cs_i, \\ \lim_{s \rightarrow \infty} c_i^b(s) &=: c_i^b, & \lim_{s \rightarrow \infty} c_i^f(s) &=: c_i^f, \end{aligned} \tag{3.6}$$

$$i = 1, \dots, M.$$

Moreover, the following relationship holds:

$$e_M c_M^f = e_1 c_1^b. \tag{3.7}$$

Proof See the Appendix.

The limits in Eq. (3.6) can be used to define estimates of performance measures for line (i)–(vi). Indeed:

- (a) Since the last machine is not blocked and the first is not starved, production rate can be estimated as

$$\begin{aligned} PR(p_1, r_1, c_1, p_2, r_2, c_2, \dots, p_M, r_M, c_M, N_1, N_2, \dots, N_{M-1}) \\ = e_M c_M^f = e_1 c_1^b. \end{aligned} \tag{3.8}$$

Here the first equality follows from (2.1) and the last from (3.7).

- (b) Based on expression (3.1) and the recursive procedure (3.5), the estimates for the probabilities of machines manufacturing starvations and blockages are:

$$\begin{aligned}ms_i &= e_i cs_i, \\mb_i &= e_i cb_i,\end{aligned}\tag{3.9}$$

where cs_i , and cb_i , are the limits of (3.5) defined in (3.6).

The accuracy of estimates (3.8) and (3.9) is discussed next.

3.3. Accuracy of the Estimates

The accuracy of the estimates (3.8) and (3.9) has been evaluated numerically. We simulated dozens of systems defined by assumptions (i)–(vi) with various machine and buffer parameters assumed. Ten of them, each illustrating a particular feature of the recursive procedure (3.5) and estimates (3.8) and (3.9), are shown in Figures 3.1–3.10. In each simulation run, zero initial conditions of all buffers and “up” states of the machines have been assumed. Then, 32,000,000 time units of warm-up period have been carried out. The time unit was defined as 1/200 of the largest average downtime of the machines. The next 32,000,000 time units were used for statistical evaluation of the production rate, \widehat{PR} , and the probabilities of manufacturing blockage and starvation, \widetilde{mb}_i and \widetilde{ms}_i , of each machine. Along with these “measured” performance characteristics, their analytical estimates (3.8), (3.9) have been calculated and the corresponding accuracy (% of error) has been determined. These data are shown in Figures 3.1–3.10 along with the machine and buffer parameters. The numbers in the circles and rectangles represent, as usually, machine production rate in isolation and buffer capacity, respectively. The rest of the data in Figures 3.1–3.10 refer to the bottleneck identification tool discussed and commented upon in Section 4.

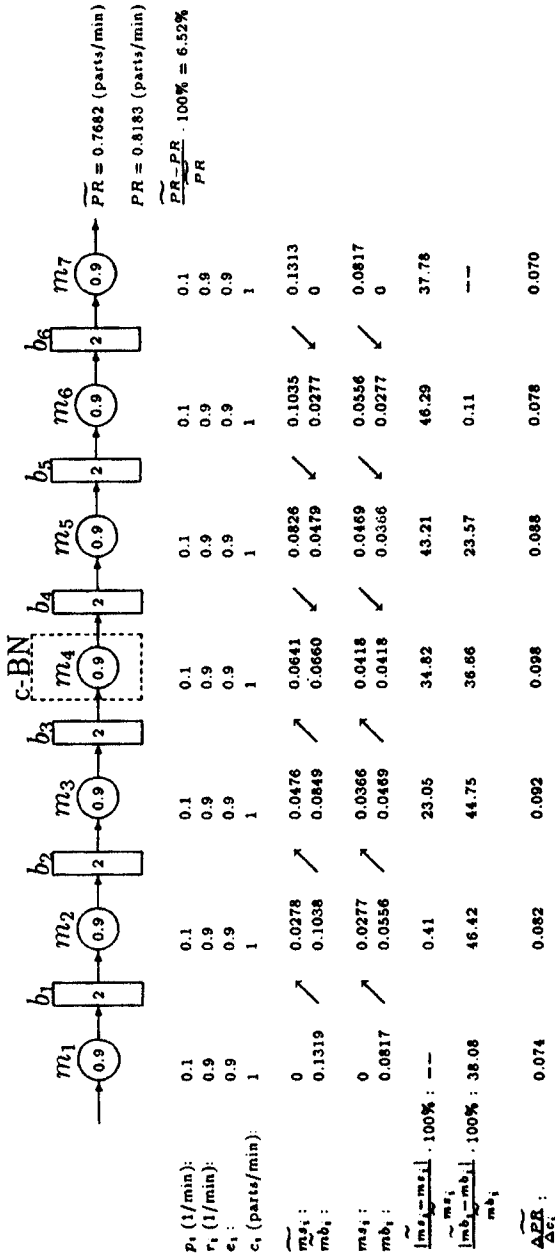

FIGURE 3.1 System 1.

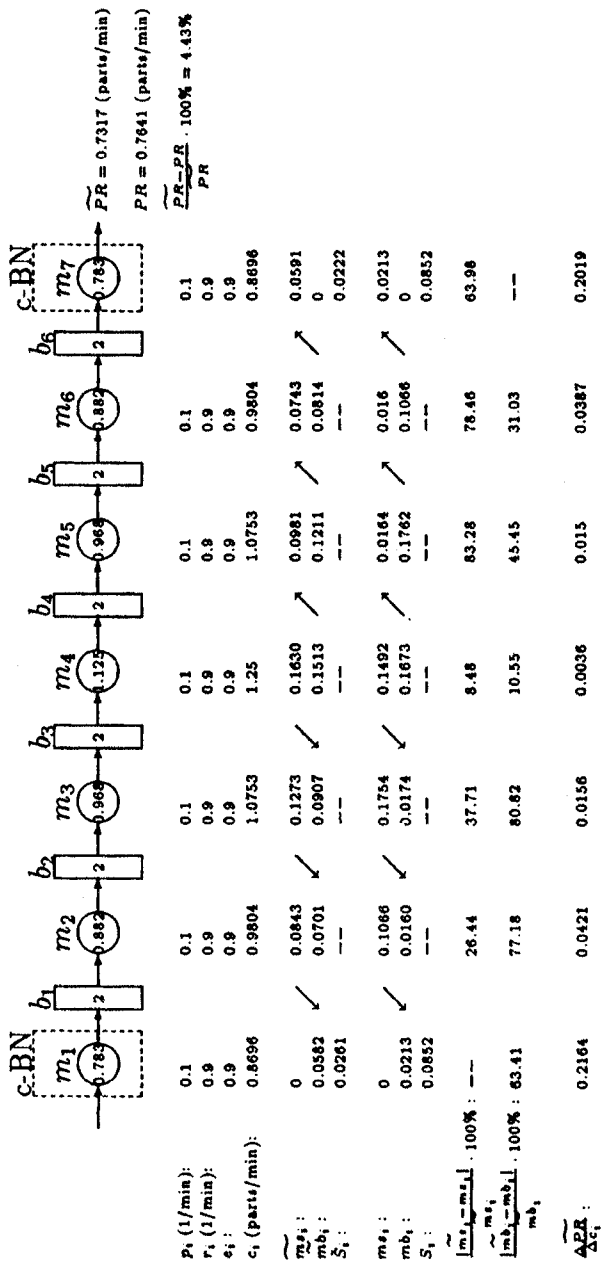

FIGURE 3.2 System 2.

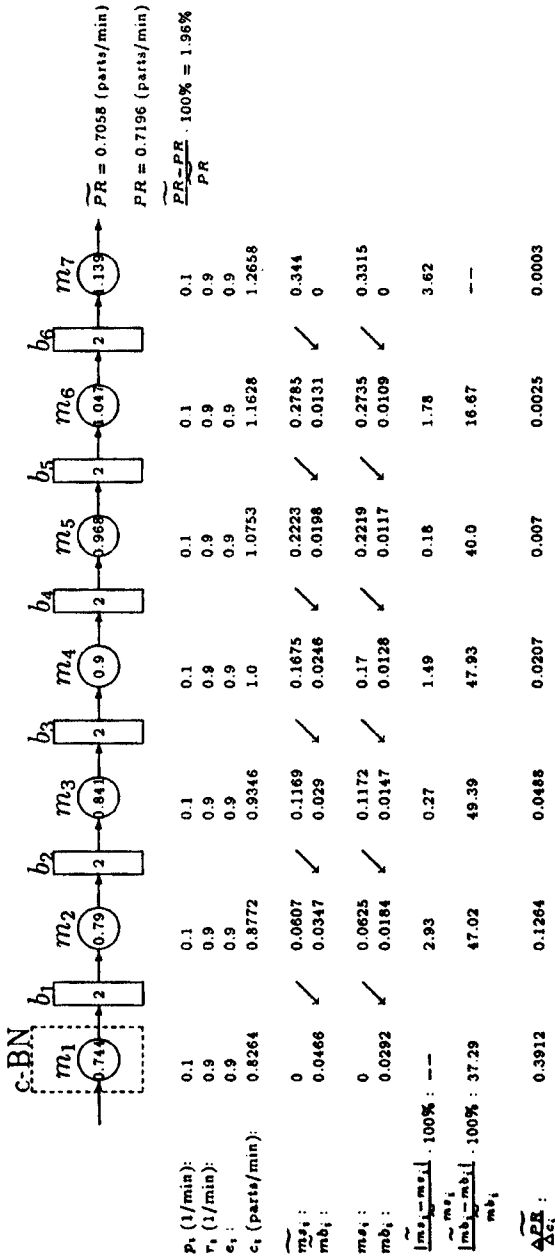

FIGURE 3.3 System 3.

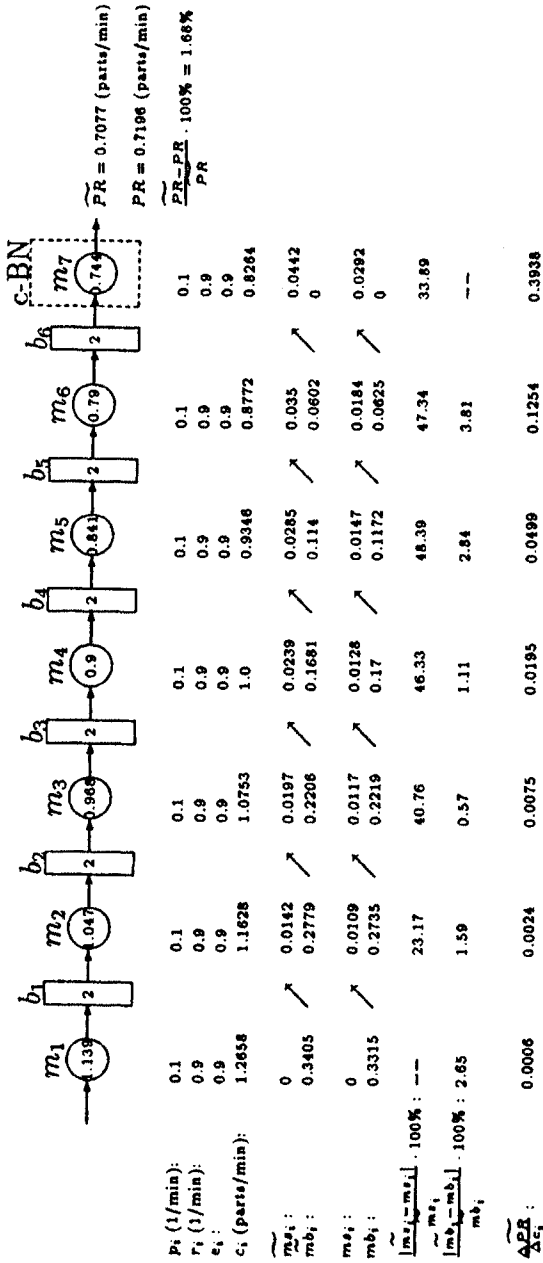

FIGURE 3.4 System 4.

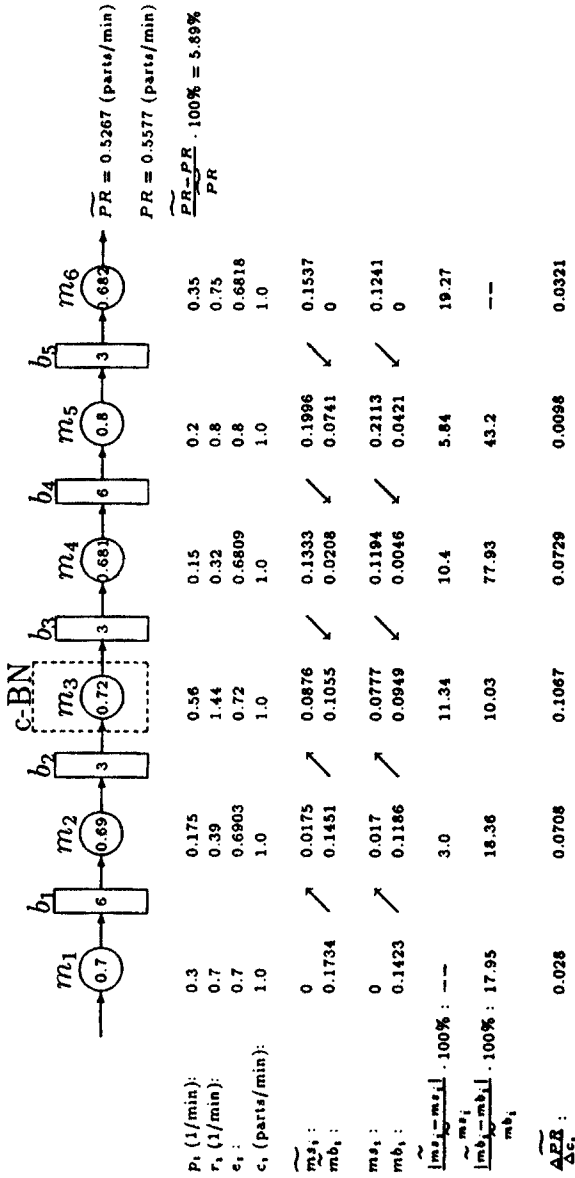

FIGURE 3.5 System 5.

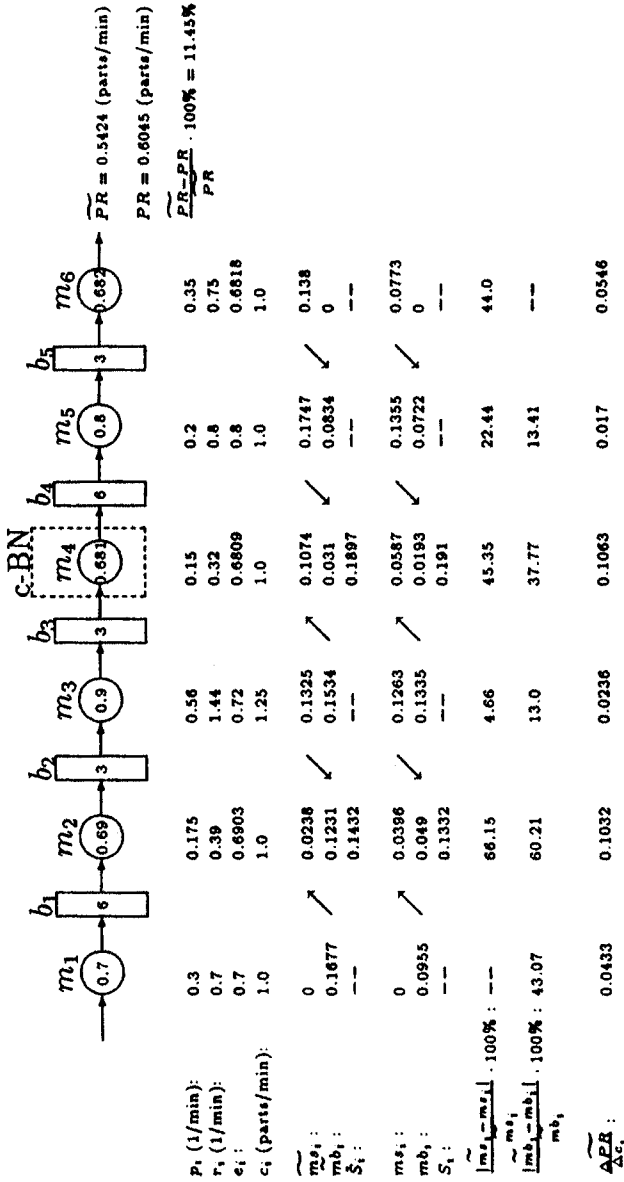

FIGURE 3.6 System 6.

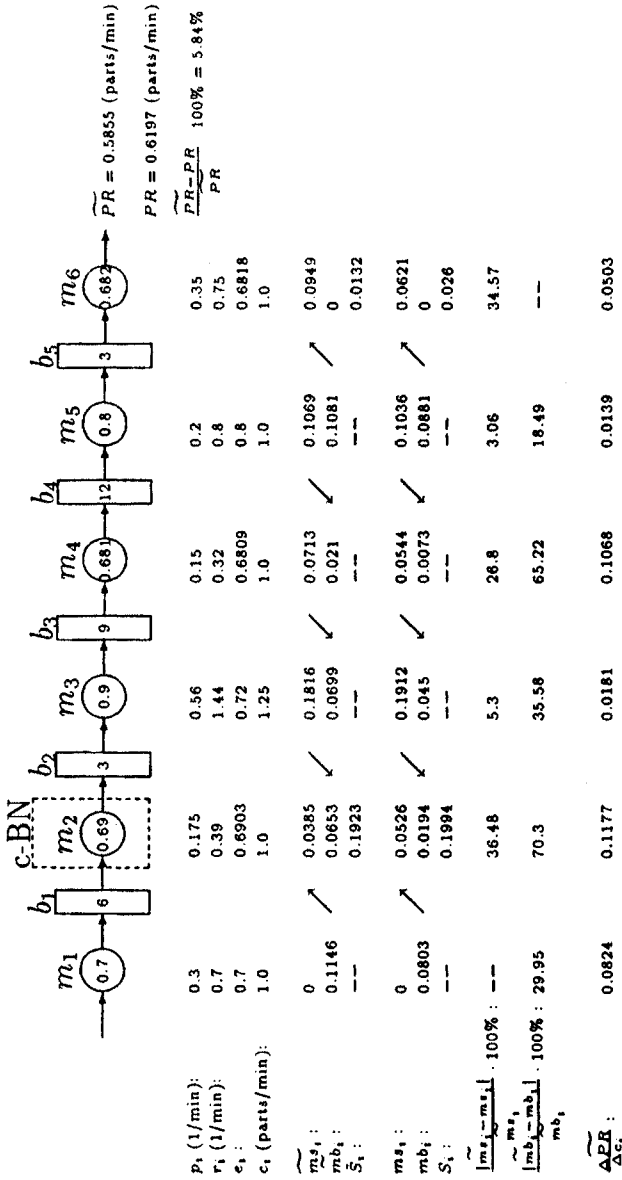

FIGURE 3.7 System 7.

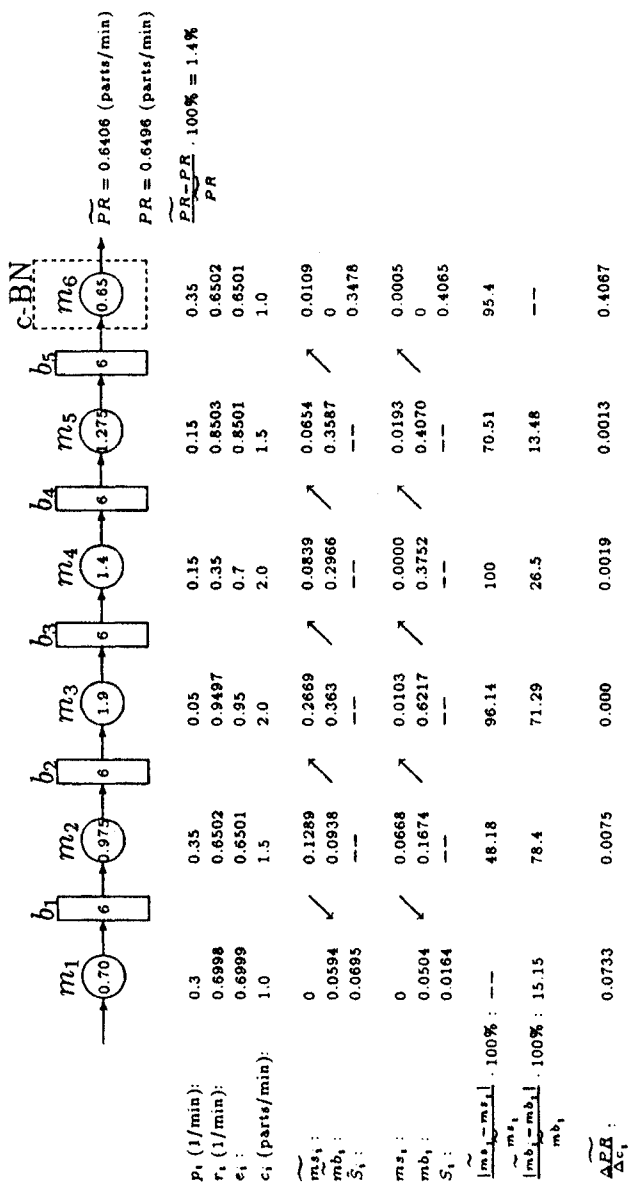

FIGURE 3.8 System 8.

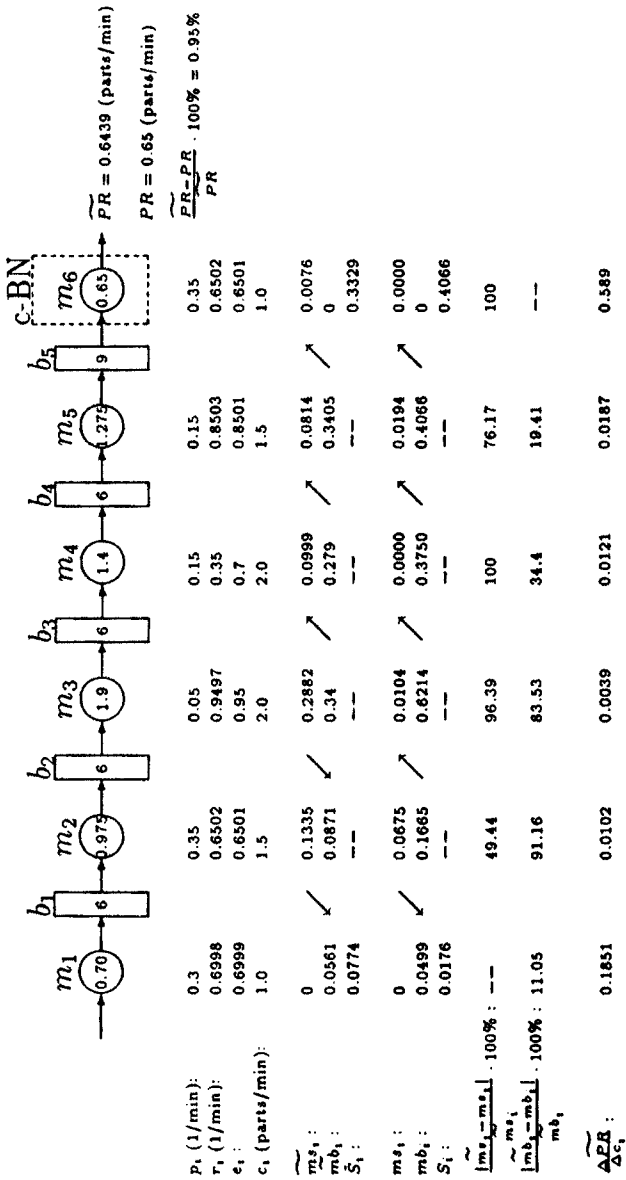

FIGURE 3.9 System 9.

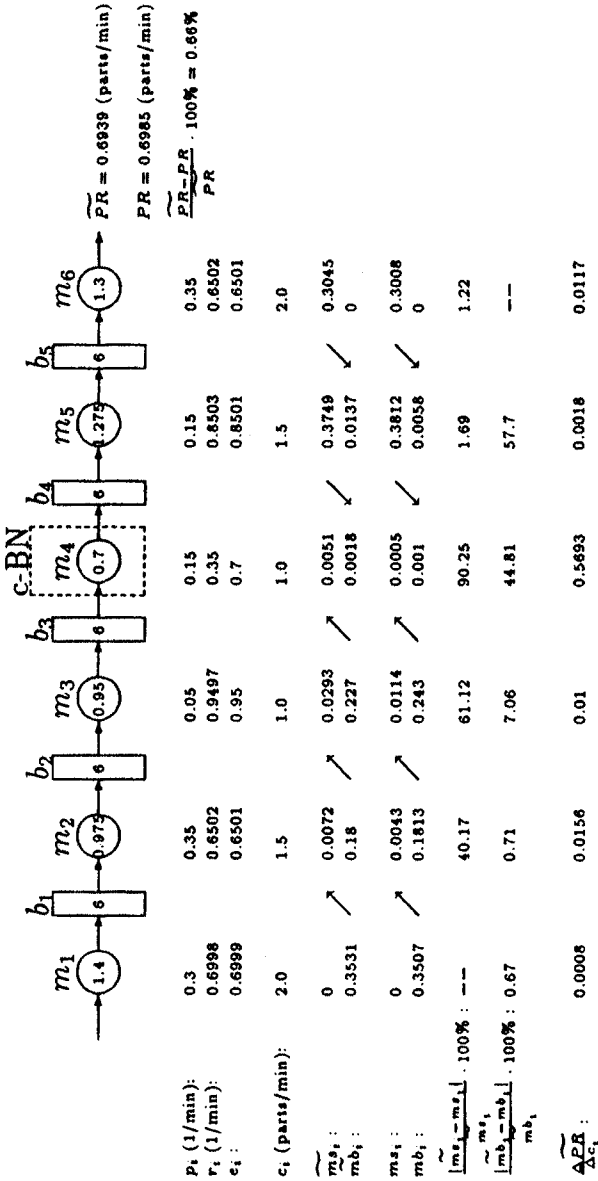

FIGURE 3.10 System 10.

Figures 3.1–3.4 represent production lines of seven machines with identical reliability characteristics, which differ only by the value of c_i 's. In all of these Figures, the c_i 's are constrained by

$$\sum_{i=1}^7 \frac{1}{c_i} = 7. \quad (3.10)$$

Since $1/c_i$ is the time necessary to process a part by the i -th machine, (3.10) is interpreted as a constraint on the total processing time of a part in each of the Systems 1–4 (Figs. 3.1–3.4).

In Figure 3.1, all c_i 's are equal to each other, in Figure 3.2 they are allocated according to an inverse “bowl” pattern, in Figure 3.3 the c_i 's are monotonically increasing as a function of i , and in Figure 3.4 they are monotonically decreasing. The accuracy of \widetilde{PR} evaluation in these systems is within 7%, however, \widetilde{ms}_i , and \widetilde{mb}_i , are evaluated with much lower accuracy (errors up to 83%).

In Figure 3.5, a production line with machines of different reliability characteristics but identical c_i 's is considered. In Figure 3.6, a similar line but with an increased c_3 is analyzed. (As it will be made clear in Section 4, machine m_3 is the bottleneck of System 5, and in System 6 this machine is improved by increasing its c_i). In System 7 (Fig. 3.7) buffers around m_4 (the new bottleneck) are increased, resulting in m_2 being the bottleneck. In Systems 5–7, the \widetilde{PR} , \widetilde{ms}_i and \widetilde{mb}_i , are identified with the accuracy of about 10% and 80%, respectively.

Systems in Figures 3.8–3.10 consist of machines with different reliability characteristics, different buffers and different c_i 's (distributed according to the inverse “bowl” pattern in Figures 3.8 and 3.9 and according to a “bowl” in Figure 3.10). In each of these Figures, the \widetilde{PR} is evaluated with the accuracy of about 1% and \widetilde{ms}_i and \widetilde{mb}_i of about 100%.

A few remarks concerning these data are in order:

1. In all cases considered, \widetilde{PR} is evaluated with a higher accuracy than \widetilde{ms} and \widetilde{mb} . Apparently, this happens because the absolute value of the latter are much smaller than that of the former, and the error of a similar (or even smaller) absolute value results in a higher percentage.

2. Even though \widetilde{PR} is evaluated, with a substantial error, given that the data available on the factory floor concerning machine and buffer parameters, are typically very unreliable and rarely are within 10% of their real values, even these non-precise estimates are of practical importance. Note also that the accuracy of \widetilde{PR} evaluation provided by (3.5)–(3.8) is of the same order of magnitude as that of [12–15].
3. As it was pointed out above, ms and mb are often evaluated by (3.9) with a very large percent of error. However, since the absolute values of the errors are quite small, these estimates work well for bottleneck machine identification, which relies on a relative, rather than absolute, values of ms and mb (see Section 4). Note that since [12–15] do not provide explicit formulas for ms_i , and mb_i evaluation, direct comparison with [12–15] is not possible.
4. The accuracy of the estimates is always lower when a reliable machine with a short cycle time is surrounded by less reliable machines with long cycle times. Apparently, this happens because the fast and reliable machine introduces strong interactions between the machines, and a weak coupling, assumed de-facto by recursive procedure (3.5), is no longer valid.
5. Recursive procedure (3.5) converges very fast: the time necessary to evaluate (3.1)–(3.9) is a fraction of a second (using Pentium 133 MHz processor). In contrast, discrete events simulations to estimate PR , \widetilde{ms} and \widetilde{mb} are hours in duration.

Estimates (3.8) and (3.9) are used below to introduce and evaluate a c-BN identification tool for production lines (i)–(vi).

4. c-BOTTLENECK IDENTIFICATION TOOL

It was shown in [5], both analytically and numerically, that the BN of a Bernoulli line is downstream of a machine if it is blocked more often than that is starved; otherwise, it is upstream. Based on this result, we postulate below a criterion for c-BN identification in Markovian lines and justify it numerically.

Consider a production line shown in Figure 4.1. Assume that its operation satisfies assumptions (i)–(vi) and assume that \widetilde{ms}_i and \widetilde{mb}_i

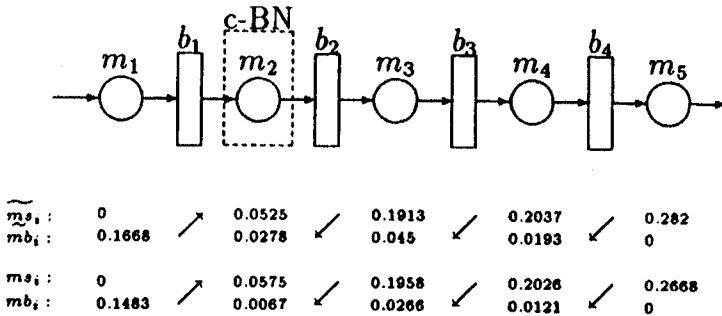

FIGURE 4.1 Illustration of BN identification.

are measured during the normal system operation. Alternatively, if these quantities are not measured, assume that they are evaluated as ms_i and mb_i , using expressions (3.9). In any case, place \widetilde{ms}_i and \widetilde{mb}_i , or/ and ms_i , and mb_i , whichever available, under each machine as shown in Figure 4.1. Using these data, assign arrows directed from one machine to another according to the following:

RULE 4.1 *If*

$$mb_j > ms_{j+1}, \quad j = 1, \dots, M - 1,$$

the arrow is directed from machine j to machine j + 1. If

$$mb_j < ms_{j+1}, \quad j = 1, \dots, M - 1,$$

the direction of the arrow is reversed.

Introduce the numbers S_i defined as follows:

$$S_1 = ms_2 - mb_1,$$

$$S_i = (mb_{i-1} + ms_{i+1}) - (mb_i + ms_i) \quad i = 2, \dots, M - 1, \quad (4.1)$$

$$S_M = mb_{M-1} - ms_M.$$

We refer to these numbers as *bottleneck severity*.

c-BN INDICATOR 4.1 *Consider a serial production line with the arrows assigned according to Rule 4.1. Then, if there is a single machine with no arrows emanating from it, this machine is the c-BN. If there are multiple*

machines with no emanating arrows, the machine with the largest severity S_i is the c-BN.

Thus, according to this Indicator, machine m_2 is the c-BN of the system shown in Figure 4.1. Note that if \widetilde{ms}_i and \widetilde{mb}_i are available through real time measurement, the c-BN is identified without any knowledge of the machine and buffer parameters p_i, r_i, c_i , and N_i .

Numerical Justification: Unlike the Bernoulli case, we were unable to justify this criterion analytically, due to extreme difficulty in calculating the derivatives of \widetilde{PR} with respect to c_i 's, as required by Definition 2.1, and then "connecting" these derivatives with the "observable" parameters, ms_i and mb_i . Therefore, only numerical justification is provided.

We simulated dozens of systems defined by assumptions (i)–(vi). As an illustration, we use ten of them shown in Figures 3.1–3.10. Along with the data commented upon in Section 3, these Figures include the arrows assigned according to Rule 4.1, sensitivities $\partial\widetilde{PR}/\partial c_i$, estimated numerically with the step $\Delta c_i = 0.05c_i$, and, wherever necessary, bottleneck severity S_i .

According to the c-BN Indicator, the c-BN of System 1 (Fig. 3.1) is machine m_4 . This conclusion follows from using either \widetilde{ms}_i and \widetilde{mb}_i or ms_i and mb_i . It is also supported by sensitivity estimates $\Delta\widetilde{PR}/\Delta c_i$.

According to c-BN Indicator, System 2 (Fig. 3.2) has two bottlenecks, m_1 and m_7 . Sensitivity estimates, $\Delta\widetilde{PR}/\Delta c_i$, indicate that only m_1 is the c-BN. This discrepancy is attributed to shortcomings of numerical simulations since, as it follows from the reversibility property [17], m_1 and m_7 have equal effect on the system production rate.

In Systems 3 and 4 (Figs. 3.3 and 3.4), machines m_1 and m_7 , respectively, are the c-BNs; this conclusion is supported by sensitivities $\Delta\widetilde{PR}/\Delta c_i$.

The c-BN in System 5 (Fig. 3.5) is m_3 , which is by far not the worst machine in the system. When this machine is improved by increasing c_3 , the c-BN shifts to m_4 (Fig. 3.6). When m_4 is protected by larger buffers (b_3 and b_4 , Fig. 3.7), the bottleneck shifts again, now to m_2 . Note that bottleneck severity, S_i , was used to arrive at these conclusions. All the above conclusions are supported by sensitivities $\Delta\widetilde{PR}/\Delta c_i$.

The c-BN in System 8 (Fig. 3.8) is m_6 , and this c-BN does not shift when it is protected by larger buffers (Fig. 3.9). The c-BN in System 10

(Fig. 3.10) is m_4 . Again, these conclusions are in agreement with the numerical estimates on the sensitivities.

Along with the above supporting examples, a few counterexamples have been discovered. Two of them are shown in Figures 4.2 and 4.3.

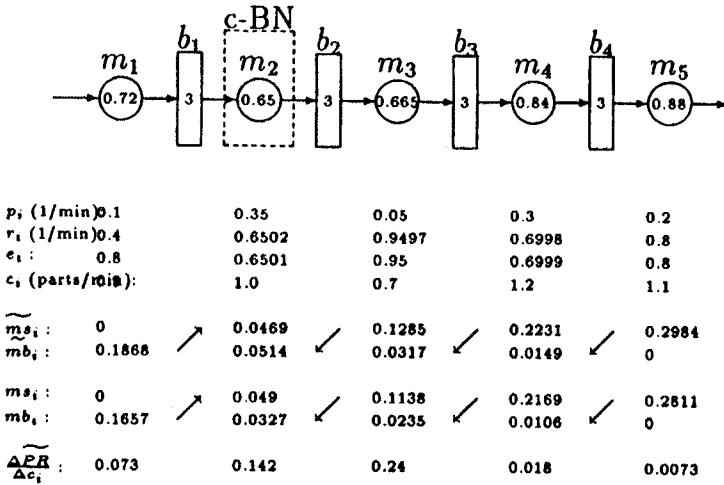

FIGURE 4.2 Counterexample 1.

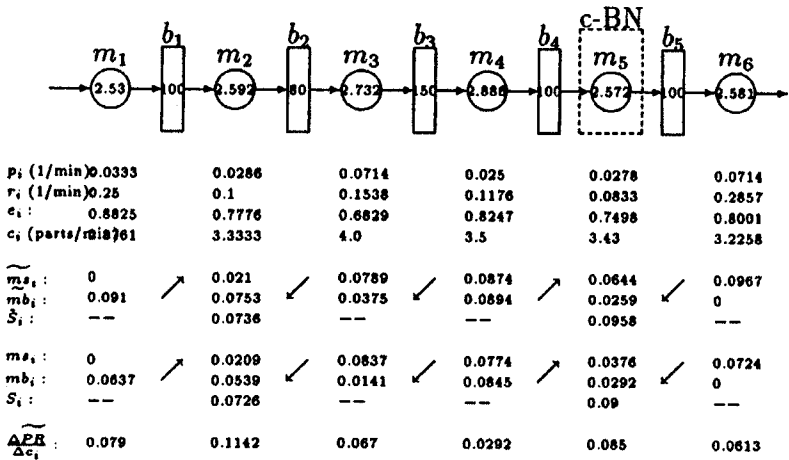

FIGURE 4.3 Counterexample 2.

In Figure 4.2, c-BN Indicator identifies m_2 as the c-BN, whereas the sensitivities reveal that m_3 is the c-BN. Similarly, in Figure 4.3, m_5 is identified as the c-BN whereas in reality m_2 has the largest effect on the \widetilde{PR} . In both cases, however, c-BN Indicator identifies the machine with the second highest effect on the \widetilde{PR} .

To investigate further the nature of these discrepancies, we simulated a system with four machines, the following constant parameters $p_1 = 0.1$, $r_1 = 0.9$, $c_1 = 1.3$, $p_2 = 0.3$, $r_2 = 0.7$, $c_2 = 1$, $p_3 = 0.2$, $r_3 = 0.8$, $c_3 = 1.2$, $p_4 = 0.25$, $r_4 = 0.75$, $N_1 = 4$, $N_2 = 4$, $N_3 = 2$ and c_4 varying between 0.5 and 1.6 (see Fig. 4.4). Within this variation, the c-BN shifts from m_4 to m_2 at slightly different values of c_4 , depending on whether the sensitivity relationship or Indicator 4.1 are used.

Since the discrepancies discovered are quite infrequent and, when they do occur, seem to be minimal, we conclude that Indicator 4.1 can be used as a tool for c-BN identification in Markovian serial production lines. ■

An application of this Indicator in a case study is discussed next.

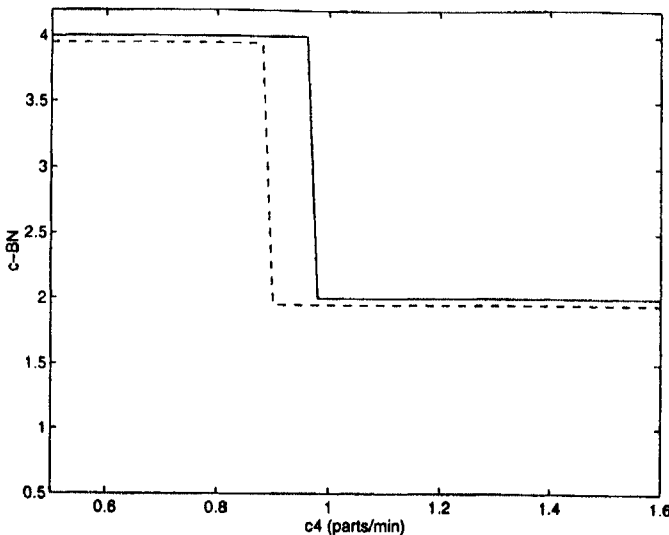

FIGURE 4.4 Comparison of c-BN Indicator 4.1 with $\max(\Delta PR/\Delta c_i)$: — : c-BN identified by $\max(\Delta PR/\Delta c_i)$; - - : c-BN identified by c-BN Indicator 4.1.

5. CASE STUDY

The c-BN indicator described above was utilized in a continuous improvement project for camshaft machining production line at an automotive engine plant. Below, modeling, analysis, and improvement measures carried out in this study are described.

5.1. Modeling

The model of the system, with the parameters identified from the machine operator log, is shown in Figure 5.1. It should be pointed out that due to numerous practical reasons, the parameters of the machines could not be assumed to be known with the accuracy more than, roughly, 10%.

To validate this model, we use recursive procedure (3.5) and calculate system production rate. Based on the data shown in Figure 5.1, this production rate is evaluated as 0.595 parts/min. The measured production rate during the period of the project was 0.55 parts/min. Since the error is about 8% and given the low accuracy of the machine parameter identification, we conclude that the model is validated.

The nominal production rate of the system, *i.e.*, when no unscheduled downtime or loading-unloading delays take place, is 0.933 parts/min. Since the system produces at the level of 0.55 parts/min, we conclude that the production losses are about 40%, which is typical for machining production lines in large volume manufacturing.

The goal of this project was to identify major causes of these losses and suggest ways for their elimination.

5.2. Bottleneck Analysis

Using the recursive procedure (3.5) and the c-BN Indicator 4.1, we identify the system c-BN (see Fig. 5.2) as Op.40. Analysis of this operation reveals that its large cycle time is due to loading-unloading delays: without these delays, the operation would produce with the cycle of 55 sec/part. Therefore, the subsequent analysis was directed towards investigation of system throughput with reduced cycle time of Op.40.

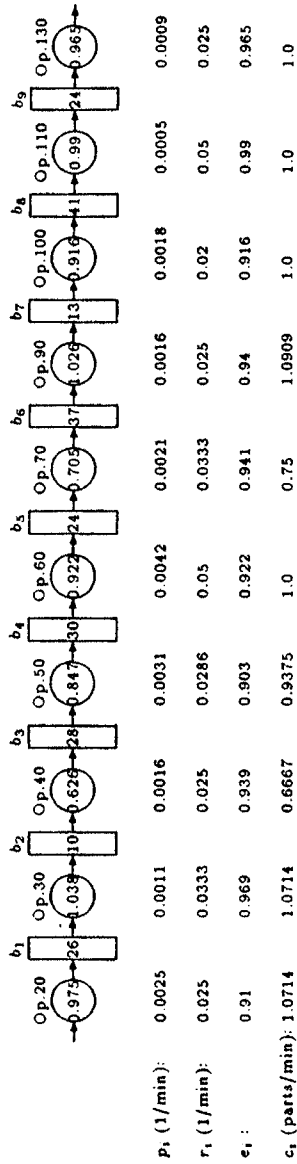

FIGURE 5.1 Production system of case study.

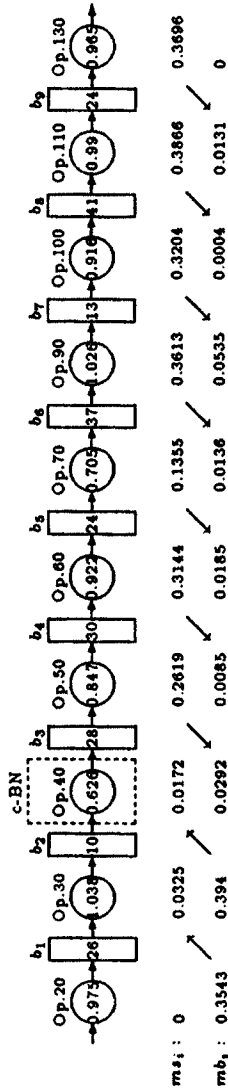

FIGURE 5.2 c-BN identification.

5.3. Improvement Measures

Table V.1 shows the effect of decreasing the cycle time of Op.40. According to these data, when the cycle time of Op.40 is reduced down to 75 sec/part, the c-BN shifts to Op.70, which is also an operation with large loading-unloading delay. Tables V.2–V.4 show the effects of decreasing cycle time of Op.70 along with the reduced cycle time of Op.40 at 70, 65, and, 60 sec/part, respectively.

As it follows from these data, decreasing the cycle time of Ops.40 and 70 to 70 sec/part will increase the *PR* to about 0.75 parts/min (26% improvement). Decreasing the cycle time of Ops.40 and 70 to 60 sec/part increases the *PR* to about 0.8 parts/min (34% improvement). Thus, a substantial performance improvement can be achieved by speeding up the appropriate operations as indicated. Improving loading-unloading operations is the most efficient route to achieve this

TABLE V.1 Reduction of loading-unloading time of Op.40

<i>Scenario</i>	<i>PR (parts/min)</i>	<i>c-BN</i>	<i>Imp. (%)</i>
Op.40: 85 sec/part	0.6283	Op.40	5.6
Op.40: 80 sec/part	0.665	Op.40	11.8
Op.40: 75 sec/part	0.68	Op.70	14.3
Op.40: 70 sec/part	0.68	Op.70	14.4
Op.40: 65 sec/part	0.68	Op.70	14.4
Op.40: 60 sec/part	0.68	Op.70	14.4

TABLE V.2 Reduction of loading-unloading time of Op.70 (Op.40: 70 sec/part)

<i>Scenario</i>	<i>PR (parts/min)</i>	<i>c-BN</i>	<i>Imp. (%)</i>
Op.70: 75 sec/part	0.7233	Op.70	21.5
Op.70: 70 sec/part	0.75	Op.40	26.1

TABLE V.3 Reduction of loading-unloading time of Op.70 (Op.40: 65 sec/part)

<i>Scenario</i>	<i>PR (parts/min)</i>	<i>c-BN</i>	<i>Imp. (%)</i>
Op.70: 75 sec/part	0.7233	Op.70	21.5
Op.70: 70 sec/part	0.77	Op.70	29.3
Op.70: 65 sec/part	0.79	Op.50	32.8

TABLE V.4 Reduction of loading-unloading time of Op.70 (Op.40: 60 sec/part)

<i>Scenario</i>	<i>PR (parts/min)</i>	<i>c-BN</i>	<i>Imp. (%)</i>
Op.70: 75 sec/part	0.7233	Op.70	21.5
Op.70: 70 sec/part	0.77	Op.70	29.3
Op.70: 65 sec/part	0.7983	Op.50	34.2
Op.70: 60 sec/part	0.8	Op.50	34.3

goal. These recommendations have been approved by plant management and implemented on the factory floor. At present the system exhibits an acceptable for the plant management performance.

6. CONCLUSIONS

Performance of production systems with Markovian machines can be improved by either improving machine reliability or increasing speed of part processing. The former was formalized by downtime- and uptime-bottlenecks (DT-BN and UT-BN), considered in [1, 2]. The latter is characterized in this paper as c-BN.

It is shown in [1, 2] (in the context of DT-BNs) and in [5] (in the context of bottlenecks in Bernoulli production lines) that probabilities of manufacturing blockage and starvation play a crucial role in BN identification. It is shown in this paper that the same probabilities can be used for c-BN identification as well. Based on these results, a hypothesis may be advanced that, irrespective of the statistics of machine reliability, these probabilities, being measured on the factory floor during the normal system operation, may be used for BN identification in the manner compatible with Indicator 4.1. If this hypothesis is true, at least to a certain extent, this offers a possibility for a unified approach to bottleneck identification. Verification of this hypothesis is a subject of future work.

Acknowledgment

The authors are grateful to Jingshan Li from the University of Michigan and Ning Zhou from Chrysler Corporation for their help with the case study. This work was supported by NSF grant DMI 9820580.

References

- [1] Chiang, S.-Y., Kuo, C.-T. and Meerkov, S.M. (April 1998) "Bottlenecks in Markovian production lines: A systems approach," *IEEE Trans. on Robotics and Automation* **14**(2), 352–359.
- [2] Chiang, S.-Y., Kuo, C.-T. and Meerkov, S.M. (Dec. 1998) "Bottlenecks in Markovian production lines: Identification and application," *Proceeding of the 37th CDC* (Tampa, Florida, USA), pp. 4344–4345.
- [3] Goldratt, E.M. and Cox, J. (1986) *The Goal* (North Rivers Press, NY).
- [4] Goldratt, E.M. (1990) *Theory of Constraints* (North River Press, Croton-on-Hudson, N.Y).
- [5] Kuo, C.-T., Lim, J.-T. and Meerkov, S.M. (April 1996) "Bottlenecks in serial production lines: A system-theoretic approach," *Mathematical Problems in Engineering* **2**(3), 233–276.
- [6] Jacobs, D., Kuo, C.-T., Lim, J.-T. and Meerkov, S.M. (1997) "A system theory for production lines," In: Paulraj, A., Roychowdhury, V. and Schaper, C.D. (Eds.), *Communication, Control and Signal Processing: A Tribute to Thomas Kailath*, (Kluwer Academic), pp. 463–480.
- [7] Kuo, C.-T., Lim, J.-T. and Meerkov, S.M. (Dec. 1996) "Bottlenecks in serial production lines: A systems approach," *Proceeding of the 34th CDC* (Kobe, Japan), pp. 2751–2756.
- [8] Kuo, C.-T., Lim, J.-T. and Meerkov, S.M. (Dec. 1996) "'Just right' operation of production systems," *Proceeding of the 34th CDC* (Kobe, Japan), pp. 2385–2386.
- [9] Sevastyanov, B.A. (1962) "Influence of storage bin capacity on the average standstill time of a production line," *Theory Prob. Appl.* **7**, 429–438.
- [10] Dallery, Y. and Gershwin, S.B. (1992) "Manufacturing flow line systems: A review of model and analytical results," *Queuing Systems* **12**, 3–94.
- [11] Viswanadham, N. and Narahari, Y. (1992) *Performance Modeling of Automated Manufacturing Systems* (Prentice Hall).
- [12] Buzacott, J.A. and Shanthikuma, J.G. (1993) *Stochastic Models of Manufacturing Systems* (Prentice Hall).
- [13] Gershwin, S.B. (1994) *Manufacturing Systems Engineering* (Prentice Hall).
- [14] Altiok, T. (1997) *Performance Analysis of Manufacturing Systems* (Springer).
- [15] Dallery, Y., David, R. and Xie, X.-L. (September 1989) "Approximate analysis of transfer lines with unreliable machines and finite buffers," *IEEE Trans. Automat. Contr.* **34**(9), pp. 943–953.
- [16] Jacobs, D. (1993) "Improvability in production systems: Theory and case studies," *Ph.D. Dissertation* (Dept. of Electrical Engineering and Computer Science, The University of Michigan, Ann Arbor, MI).
- [17] Muth, E. (1979) "The reversability property of production lines," *Management Sci.* **25**, 152–158.

APPENDIX

To prove Theorem 3.1, we need the following three facts.

LEMMA A.1 Consider $c_i^f(s)$, $c_i^b(s)$, and $cb_i(s)$, $i = 1, \dots, M$, defined by recursive procedure (3.5). If $c_j^f(s) < c_j^f(s-1)$, $j = 2, \dots, M$, then $c_j^b(s+1) > c_j^b(s)$ and $cb_j(s+1) < cb_j(s)$, $j = 1, \dots, M-1$.

Proof For $j = M-1$, from (3.5), we obtain

$$\begin{aligned} & cb_{M-1}(s+1) \\ &= \frac{e_{M-1}c_{M-1}^f(s) - \widetilde{PR}(p_{M-1}, r_{M-1}, c_{M-1}^f(s), p_M, r_M, c_M^b(s+1), N_{M-1})}{e_{M-1}c_{M-1}^f(s)} \\ &= 1 - \frac{\widetilde{PR}(p_{M-1}, r_{M-1}, c_{M-1}^f(s), p_M, r_M, c_M, N_{M-1})}{e_{M-1}c_{M-1}^f(s)}. \end{aligned}$$

Since $[\widetilde{PR}(p_1, r_1, c_1, p_2, r_2, c_2, N_1)]/e_i c_i$, $i = 1, 2$, is monotonically decreasing as a function of c_i , $i = 1, 2$, and $c_{M-1}^f(s) < c_{M-1}^f(s-1)$,

$$\begin{aligned} & cb_{M-1}(s+1) \\ &< 1 - \frac{\widetilde{PR}(p_{M-1}, r_{M-1}, c_{M-1}^f(s-1), p_M, r_M, c_M, N_{M-1})}{e_{M-1}c_{M-1}^f(s-1)} \\ &= \frac{e_{M-1}c_{M-1}^f(s-1) - \widetilde{PR}(p_{M-1}, r_{M-1}, c_{M-1}^f(s-1), p_M, r_M, c_M, N_{M-1})}{e_{M-1}c_{M-1}^f(s-1)} \\ &= cb_{M-1}(s). \end{aligned}$$

Hence, from (3.5),

$$\begin{aligned} c_{M-1}^b(s+1) &= c_{M-1} \left[1 - cb_{M-1}(s+1) \right] \\ &> c_{M-1} \left[1 - cb_{M-1}(s) \right] \\ &= c_{M-1}^b(s). \end{aligned}$$

Due to the monotonicity of $\widetilde{PR}(p_1, r_1, c_1, p_2, r_2, c_2, N_1)$ with respect to $c_i, i = 1, 2$,

$$\begin{aligned} cb_j(s+1) &= 1 - \frac{\widetilde{PR}(p_j, r_j, c_j^f(s), p_{j+1}, r_{j+1}, c_{j+1}^b(s+1), N_j)}{e_j c_j^f(s)} \\ &< 1 - \frac{\widetilde{PR}(p_j, r_j, c_j^f(s), p_{j+1}, r_{j+1}, c_{j+1}^b(s), N_j)}{e_j c_j^f(s)} \\ &< 1 - \frac{\widetilde{PR}(p_j, r_j, c_j^f(s-1), p_{j+1}, r_{j+1}, c_{j+1}^b(s), N_j)}{e_j c_j^f(s-1)} \\ &= cb_j(s), \quad j = 1, 2, \dots, M-2. \end{aligned}$$

Therefore,

$$\begin{aligned} c_j^b(s+1) &= c_j [1 - cb_j(s+1)] > c_j [1 - cb_j(s)] \\ &= c_j^b(s), \quad j = 1, 2, \dots, M-2. \end{aligned} \quad \blacksquare$$

LEMMA A.2 Consider $c_i^f(s)$, $c_i^b(s)$, and $cs_i(s)$, $i = 1, \dots, M$, defined by recursive procedure (3.5). If $c_j^b(s+1) > c_j^b(s)$, $j = 1, \dots, M-1$, then $c_j^f(s+1) < c_j^f(s)$ and $cs_j(s+1) > cs_j(s)$, $j = 2, \dots, M$.

Proof Similar to that of Lemma A.1.

LEMMA A.3 For all $j = 2, \dots, M$, sequences $c_j^f(s)$ and $cs_j(s)$, $s = 0, 1, \dots$, are monotonically decreasing and increasing, respectively. For all $j = 1, \dots, M-1$, sequences $c_j^b(s)$ and $cb_j(s)$, $s = 0, 1, \dots$, are monotonically increasing and decreasing, respectively.

Proof By induction: For $s = 0$, we have

$$\begin{aligned} c_j^f(1) &= c_j [1 - cs_j(1)] = c_j \frac{\widetilde{PR}(p_{j-1}, r_{j-1}, c_{j-1}^f(1), p_j, r_j, c_j^b(1), N_{j-1})}{e_j c_j^b(1)} \\ &< c_j = c_j^f(0), \quad 2 \leq j \leq M. \end{aligned}$$

Assume that for $s > 0$,

$$c_j^f(s) < c_j^f(s-1), \quad 2 \leq j \leq M.$$

Then, by Lemma A.1,

$$cb_j(s+1) < cb_j(s), \quad c_j^b(s+1) > c_j^b(s), \quad 1 \leq j \leq M-1.$$

By Lemma A.2,

$$cs_j(s+1) > cb_j(s), \quad c_j^f(s+1) < c_j^f(s), \quad 2 \leq j \leq M. \quad \blacksquare$$

Proof of Theorem 3.1 Since \widetilde{PR} is bounded, sequences $c_j^f(s)$, $cs_j(s)$, $c_j^b(s)$ and $cb_j(s)$, $1 \leq j \leq M$, are bounded from above and below. Since, in addition, they are monotonic (Lemma A.3), they are convergent.

To prove that $e_M c_M^f = e_1 c_1^b$, consider the steady state equations of the recursive procedure (3.5):

$$\begin{aligned} cb_i &= \frac{[e_i c_i^f - \widetilde{PR}(p_i, r_i, c_i^f, p_{i+1}, r_{i+1}, c_{i+1}^b, N_i)]}{e_i c_i^f}, \quad 1 \leq i \leq M-1, \\ c_i^b &= c_i [1 - cb_i], \quad 1 \leq i \leq M-1, \\ cs_i &= \frac{[e_i c_i^b - \widetilde{PR}(p_{i-1}, r_{i-1}, c_{i-1}^f, p_i, r_i, c_i^b, N_{i-1})]}{e_i c_i^b}, \quad 2 \leq i \leq M, \\ c_i^f &= c_i [1 - cs_i], \quad 2 \leq i \leq M. \end{aligned} \quad (\text{A.1})$$

Introduce $(M-1)$ two machine—one buffer production lines L_i , $i = 1, \dots, M-1$, where the first machine is defined by p_i, r_i , and c_i^f , the second machine by p_{i+1}, r_{i+1} and c_{i+1}^b , and the buffer by N_i . The following properties hold:

Let PR_i be the production rate of line L_i , $i = 1, \dots, M-1$, and let $PR_M = e_M c_M^f$. Then, $PR_i = e_i c_i^f c_i^b / c_i$, $i = 1, \dots, M$. Moreover,

$PR_i = PR_j, \forall j$. The proof of these properties is as follows: From (A.1), for $1 \leq i \leq M-1$, we have

$$PR_i = e_i c_i^f (1 - cb_i) = \frac{e_i c_i^f}{c_i} c_i (1 - cb_i) = \frac{e_i c_i^f c_i^b}{c_i}. \quad (\text{A.2})$$

Hence,

$$PR_i = \frac{e_i c_i^f c_i^b}{c_i}, \quad i = 1, \dots, M-1,$$

and

$$PR_M = e_M c_M^f = \frac{e_M c_M^f c_M}{c_M} = \frac{e_M c_M^f c_M^b}{c_M}.$$

Therefore,

$$PR_i = \frac{e_i c_i^f c_i^b}{c_i}, \quad i = 1, \dots, M. \quad (\text{A.3})$$

In addition, from (A.1),

$$\begin{aligned} PR_i &= \frac{e_i c_i^f c_i^b}{c_i} \\ &= e_i c_i^b (1 - cs_i) \\ &= PR_{i-1}, \quad i = 2, \dots, M. \end{aligned}$$

From the above properties, we obtain

$$PR_1 = \frac{e_1 c_1^f c_1^b}{c_1} = \frac{e_M c_M^f c_M^b}{c_M}. \quad (\text{A.4})$$

Since $c_1^f = c_1$ and $c_M^b = c_M$,

$$PR = e_1 c_1^b = e_M c_M^f. \quad (\text{A.5})$$

■



Hindawi

Submit your manuscripts at
<http://www.hindawi.com>

