

# Chapter 7

## C. S. Peirce and Intersemiotic Translation

João Queiroz and Daniella Aguiar

### 7.1 Introduction

Intersemiotic translation (IT) is a phenomenon of interest in many fields of research such as comparative literature, translation studies, interarts, and intermediality studies. After Jakobson's definition, the term became broader and now it designates relations between systems of different natures, and it is not restricted to the interpretation of verbal signs (Cluver 1997, p. 43; Gorrée 2007; Plaza 1987). Consequently, this process is observed in several semiotic phenomena, including literature, cinema, comics, poetry, dance, music, theater, sculpture, painting, video, and so on. Among the most thought-provoking questions to which no systematic effort has been directed, figures the following: how to model, in the domain of Peirce's theory of sign, an IT? Our purpose here is to present a model of IT based on Peirce's philosophy of signs. We begin with a brief introduction of the topic through the notion of creative translation as transcreation. Then, we introduce the Peircean model of semiosis and his fundamental classification of signs. We conclude by describing a case of translation from literature (Gertrude Stein) to dance (Paul Lightfoot and Sol Leon).

---

J. Queiroz (✉)

Institute of Arts and Design, Federal University of Juiz de Fora (UFJF), Juiz de Fora, Brazil  
e-mail: queirozj@pq.cnpq.br

D. Aguiar

Graduate Program on Literary Studies, Federal University of Juiz de Fora (UFJF), Juiz de Fora, Brazil  
e-mail: daniella.aguiar@gmail.com

## 7.2 On Campos's Notion of Creative Translation

It is well known in Jakobson's thesis that, in poetry, "verbal equations" constitute a primary organizing principle—the constituents (syntactic and morphological categories, the roots, the phonemes, and distinctive marks) are confronted and juxtaposed, placed in "contiguity relationships" according to the "similarity and contrast principle" (Jakobson 1980, p. 84). The "grammar of the poetry" requires from the translator a detailed *recreation* program of parallelisms between several levels of description of the source sign (e.g., phonological, syntactic, morphological, semantic, and pragmatic).

Among grammatical categories utilized for parallelisms and contrasts we actually find all the parts of speech, both mutable and immutable: numbers, genders, cases, grades, tenses, aspects, moods, voices, classes of abstract and concrete words, animates and inanimates, appellatives and proper names, affirmatives and negatives, finite and infinite verbal forms, definite and in-definite pronouns or articles, and diverse syntactic elements and constructions. (Jakobson 1980, p. 84)

As the Brazilian poet and translator Haroldo de Campos emphasized, the translation of poetry is not centered on the reconstitution of the referential message, but on the *transcreation* (see Campos 2007, p. 315) of several levels of semiotic processes. It is almost a consensus that, on this subtype of interlinguistic translation, there are other relevant levels of description to consider. According to Campos, supported by Jakobson's notion of poetic function of language and opposed to the idea of translation as "message transmission," in a creative translation of poetry we translate the sign itself, its own materiality:

Of course in a translation of this type not only the signified but also the sign itself is translated, that is, the sign tangible self, its very materiality (sonorous properties, graphical-visual properties all of that which forms, for Charles Morris, the iconicity of the aesthetic sign, when an iconic sign is understood as that which is 'in some degree similar to its denotation'.) The signified, the semantic parameter, becomes just a kind of boundary marker for the "re-creative" enterprise. (Campos 2007, p. 315)

For Campos (2007, p. 315, 1997, 1992), creative translation is an iconic (isomorphic or paramorphic) *transcreation* of "verbal equations"—"an isomorph translation would be, by definition, an iconic translation" (Campos 1997, p. 52). The translation *transcreates* a multilevel system of relations (see Fig. 7.1).

Eco (2007, p. 95) summarizes in a very precise way the relationship between different levels. He assumes it is possible, for instance, that the referential content of a poem could be neglected to benefit the rhythm, according to a *negotiation* between loss and gain. This means that, in some levels, the target text is not "equivalent" to the source text, because the translator must choose among the aspects considered interpretively more relevant.

The problem of relations between various descriptive levels affects particularly the phenomenon of IT. It seems theoretically natural to describe an interlinguistic translation by establishing direct correlations between equivalent semiotic levels of description—morphological-morphological, phonetic-phonetic, rhythmic-rhythmic (see Jakobson and Pomorska 1985; see Fig. 7.1). However, an IT does not exhibit

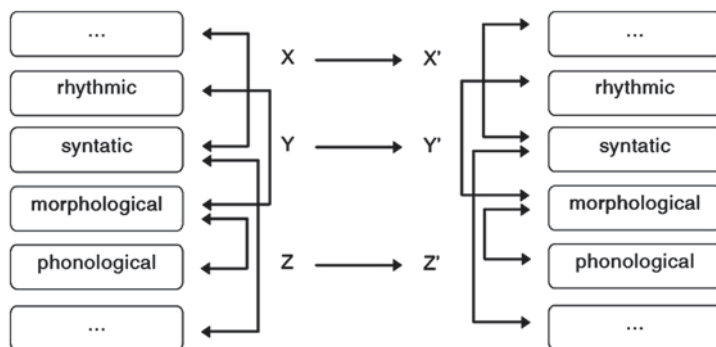

**Fig. 7.1** Translation can be modeled as the *transcreation* of a multilevel system of relations. The figure depicts two types of relations: (i) the hypothetical “constraints” between different levels in sign source (X, Y, Z) and sign target (X', Y', Z') and (ii) an *iconic mapping* between the descriptive levels from the source sign into the target sign

the same principle of corresponding levels. Therefore, the main theoretical difficulty relates to the comparison between radically different semiotic systems and their specific levels of description. That supposition depends on the idea of a semiotic system as a *multilevel system*, as we have argued in other papers (see Queiroz and El-Hani 2006). Accordingly, an IT can be described as a relation between *multilevel systems*, where levels are coordinated in terms of mutual constraints. In this sense, although we can describe the “scenic dance space,” for instance, without reference to “movement dynamic morphology,” in fact they are mutually constraining each other.

IT operates on different levels, selecting relevant aspects from the source and translating them into the target according to new materials and processes. For example, from literature to dance, linguistic and paralinguistic components (rhythm, prosody, syntax, or psychological ambience) are translated into dynamic of movement, organization of space, light design, costumes, scenography, etc. Notably, a “mapping of correlations” cannot be easily established between levels of different nature (different semiotic systems; Fig. 7.2). If a translation from a literary work into a dance choreography results in very different materials and structures, how to compare “semiotics source and target”? In any case, possibilities of conceptual mapping (probably nonunivocal) between different systems and levels should be provided. A basic graphic model (Fig. 7.2) represents this problem.

We introduce the notion of level of description in a more general perspective of semiosis (sign action). The application of Peircean triadic model of semiosis to the translated-interpreter-translator relationship was initially proposed by Steconni (1999), and more recently by Hodgson (2007). Plaza (1987) is probably the first attempt to develop an IT approach to the phenomenon based on Peirce’s model and typology of signs combined with Campos’ notion of creative translation as *transcreation*.<sup>1</sup> Gorrée (1994, 2007), Damiani (2008), and Jeha (1997) are among the

<sup>1</sup> For Plaza (1987), there are three types of intersemiotic translation: iconic, indexical, and symbolic. He also suggests examples involving poetry and visual arts, including new digital media.

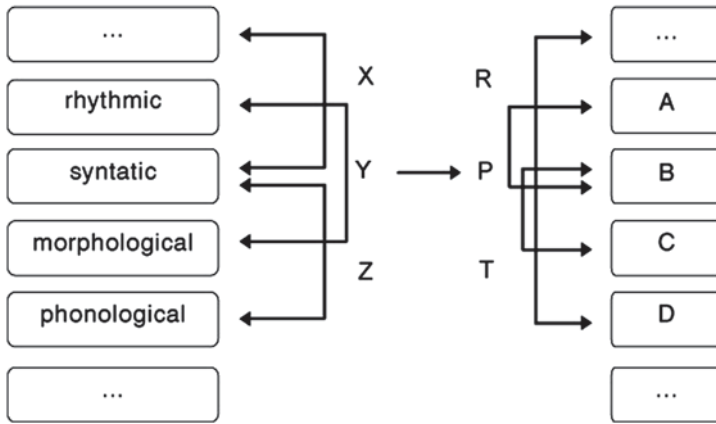

Fig. 7.2 The figure depicts two types of relations: (i) hypothetical relations between different levels in sign-source (X, Y, Z) and sign target (R, P, T) and (ii) an iconic mapping between the descriptive levels from the source system into the target system

authors who consider Peirce’s model of semiosis adequate to translation studies in general.

Our approach is based on the premise that IT is fundamentally an irreducible triadic relation (semiosis). Beyond that, as many authors have claimed (see Petrilli and Ponzio 2010; Gorrée 1994, p. 10, 2005; Plaza 1987), we assert that IT is predominantly a multilayered iconic relation (see Queiroz and Aguiar 2013; Aguiar and Queiroz 2009, 2010, 2011a, b). Here, we explore some consequences of those perspectives.

### 7.3 Peirce, Semiosis, and Semiotics

Charles Sanders Peirce,<sup>2</sup> founder of the modern theory of signs, defined semiotics as a kind of logic: a science of the essential and fundamental nature of all possible varieties of meaning processes (semiosis; see Queiroz and Merrell 2009). Peirce’s semiotics is grounded on a list of logicalphenomenological categories—firstness, secondness, and thirdness—which corresponds to an exhaustive system of hierarchically organized classes of relations (see Houser et al. 1997). This system makes up the formal foundation of his model of semiosis and of his classifications of signs (Murphey 1993, pp. 303–306). In brief, the categories can be defined as: (1) firstness: what is such as it is, without reference to anything else; (2) secondness: what

<sup>2</sup> We shall follow the practice of citing from the Collected Papers of Charles Sanders Peirce (1931–1935, 1958) by volume number and paragraph number, preceded by “CP”; the Essential Peirce by volume number and page number, preceded by “EP.” References to the microfilm edition of Peirce’s papers (Harvard University) will be indicated by “MS,” followed by the manuscript number.

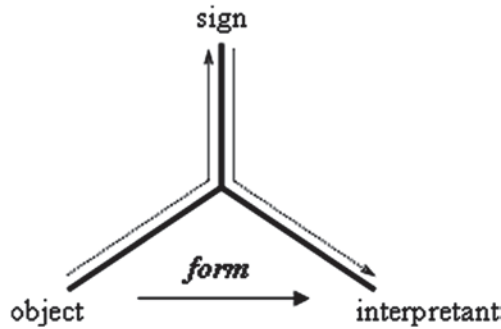

**Fig. 7.3** Semiosis as a relation between three irreducibly connected terms (sign-object-interpretant, S-O-I). This triadic relationship communicates/conveys a form from the object to the interpretant through the sign (symbolized by the *horizontal arrow*). The other two *arrows* indicate that the form is conveyed from the object to the interpretant through a determination of the sign by the object, and a determination of the interpretant by the sign

is such as it is, in relation with something else, but without relation with any third entity; and (3) thirdness: what is such as it is, insofar as it is capable of bringing a second entity into relation with a first one in the same way that it brings itself into relation with the first and the second entities. Thirdness (triadic relation) is the category of mediation, habit, generality, and semiosis (CP 1.340; for further on categories, see Hookway 1985; Savan 1987; Murphey 1993).

According to Peirce's model, any description of semiosis involves a relational complex constituted by three terms irreducibly connected by relations of determination—Sign, Object, and Interpretant (S-O-I). The irreducibility indicates a logical property of this complex: the sign process must be regarded as associated with the interpretant, as an ongoing process of interpretation (Hausman 1993, p. 9), and it is not decomposable into any simpler relation. If we consider only a dyadic relation, S-I, S-O, or I-O, or an element of a triad in itself, we will not be able to infer how they would behave in a triadic relation, S-O-I (EP 2:391).

[...] by 'semiosis' I mean [...] an action, or influence, which is, or involves, a cooperation of three subjects, such as a sign, its object, and its interpretant, this tri-relative influence not being in any way resolvable into actions between pairs. (CP 5.484)

The relations of determination provide the way the elements in a triad are arranged in semiosis. According to Peirce, the Interpretant is determined by the Object through the mediation of the Sign (I is determined by O through S; MS 318: 81). This is a result from two determinative relations: the determination of the Sign by the Object relatively to the Interpretant (O determines S relatively to I), and the determination of the Interpretant by the Sign relatively to the Object (S determines I relatively to O; De Tienne 1992).

Semiosis can also be pragmatically defined as a medium for the communication to the interpretant of a form embodied in the object, so as to constrain, in general, the interpreter's behavior (Fig. 7.3):

[...] a Sign may be defined as a Medium for the communication of a Form. [...]. As a medium, the Sign is essentially in a triadic relation, to its Object which determines it, and to its Interpretant which it determines. [...]. That which is communicated from the Object through the Sign to the Interpretant is a Form; that is to say, it is nothing like an existent, but is a power, is the fact that something would happen under certain conditions. (Peirce MS 793:1–3. See EP 2.544, n.22, for a slightly different version)

The object of sign communication is a habit embodied as a constraining factor of interpretative behavior—a logically “would be” fact of response. The form is something that is embodied in the object as a “regularity” or a “disposition.” The communication of a form from the object to the interpretant constrains the behavior of the interpreter in the sense that it brings about a constrained set of object effects on the interpreter through the mediation of a sign.

As it is well known, sign-mediated processes show a notable variety. The morphological variety of semiotic processes is usually reduced to three (nonexcludent) classes of signs based on sign-object relation (icon, index, symbol; see Atkin 2010). Peirce characterized icons, indexes, and symbols as matching, respectively, relations of similarity, contiguity, and law between S and O (sign-object relation) in the triad S-O-I. In iconic sign process, the form which is communicated from the object to the interpretant through the sign is a general similarity between the object and the sign. Generally speaking, an iconic sign communicates a habit embodied in an object to the interpretant, so as to constrain the interpreter’s behavior, as a result of a certain quality that the sign and the object share. In contrast, if S is a sign of O by reason of “a direct physical connection” between them, then S is said to be an index of O. Generally speaking, an indexical sign communicates a habit embodied in an object to the interpretant as a result of a direct physical connection between sign and object. Finally, in a symbolic relation, the interpretant stands for “the object through the sign” by a determinative relation of law, rule, or convention (CP 2.276). In this symbolic sign process, the form, which is communicated from the object to the interpretant through the sign, is a lawful relationship between a given kind of sign and a given type of object. Generally speaking, a symbolic sign communicates a habit embodied in an object to the interpretant as a result of a regularity in the relationship between sign and object (law or rule).

Iconic processes have special importance in our approach. We could say (*a la* Wittgenstein) that the icon *shows* its meaning through its material form (see Fabbrichesi 2011). We know, at least since Charles Morris (1971), that the aesthetic sign is predominantly iconic (see also Zeman 1977, pp. 241–258).

## 7.4 Intersemiotic Translation as an Iconic-Dependent Process

The idea of translation as a predominantly iconic process has been proposed by Petrilli and Ponzio (2010), and other authors (see Gorrée 1994, p. 10, 2005). We have approached the same idea focusing the phenomenon of IT, especially from literature to dance (see Queiroz and Aguiar 2013; Aguiar and Queiroz 2011b, 2013).

The icon is a type of sign inextricably linked to its object, an analogue of its own composition, formal, structural, and/or material nature. It *stands for* its object through its form, structure, or material constitution (W 3: 62–65). But we have developed the idea of iconicity, central to Petrilli and Ponzio’s thesis, and strongly associated by Haroldo de Campos to the concept of *transcreation*, in new directions (see Queiroz and Aguiar 2013; Queiroz 2010). When an “operational criterion” is adopted (Hookway 2000, p. 102; Stjernfelt 2011), the icon is defined as anything whose manipulation can reveal more information about your object, and algebra, syntax, graphs, and the formalization of all types should be recognized as icons. In short, an icon is characterized as a sign that reveals information through a procedure followed by observation.

The key of iconicity is not perceived resemblance between the sign and what it signifies but rather the possibility of making new discoveries about the object of a sign through observing features of the sign itself. Thus a mathematical model of a physical system is an iconic representation because its use provides new information about the physical system. This is the distinctive feature and value of iconic representation: a sign resembles its object if, and only if, study of the sign can yield new information about the object. (Hookway 2000, p. 102)

This operational property is considered a detrievilization of the notion that the icon is fundamentally based on a relation of similarity (Stjernfelt 2000, pp. 357–392). Such property is clearly manifested in creative translations, as Haroldo de Campos (2007, pp. 323, 325) stressed—“translation is the most attentive way of reading.”

If translation is a privilege form of critical reading, it will be by means of translation that one can lead other poets, readers, and students of literature to an understanding of the most profound workings of the artistic text, its most intimate mechanisms and gears. (Campos 2007, p. 325)

## 7.5 Intersemiotic Translation as Semiosis

There are important consequences of Peirce’s modeling of sign process in the domain of IT research. Peirce’s model describes semiosis as essentially triadic, dynamic, interpreter dependent, and materially extended (embodied; see Queiroz and Merrell 2009). An IT is emphatically a triadic (S-O-I) relation, not a dyadic-bilateral one. There are two possible explanatory models here. The sign is the semiotic source (translated work). The object of the translated sign is the object of the semiotic source and the interpretant (produced effect) is the semiotic target (translator sign) (Fig. 7.4).

According to the second model, the sign is the semiotic target (translator sign). The object of the sign is the semiotic source (translated work) and the interpretant is the effect produced on the interpreter (interpretant) (Fig. 7.5).

According to the process described above, the “form” communicated from the object to the effect (interpretant) and produced by means of the sign is different in each version. How can these differences be helpful? We should speculate about how those alternatives provide insights about the phenomenon examined (see the Sect. 7.7).

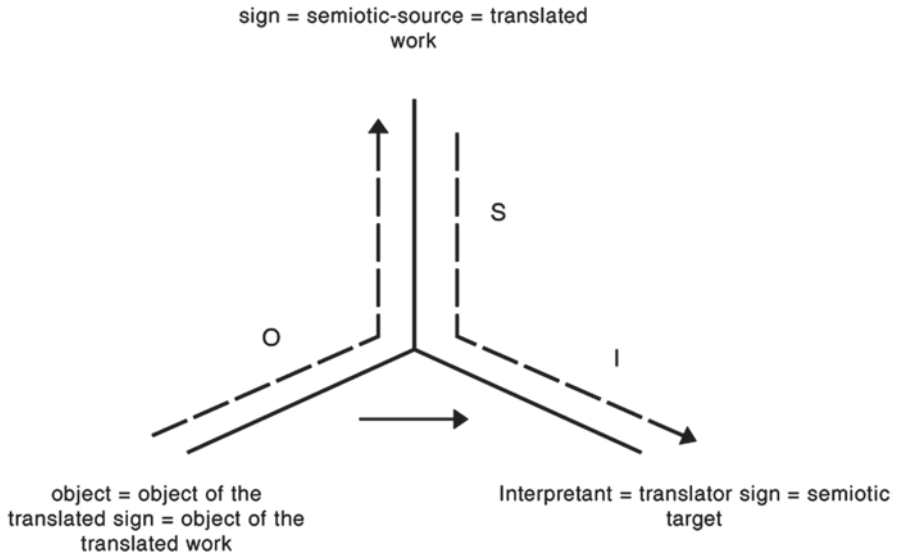

Fig. 7.4 Triadic relation in which the sign is the translated work, the object of the sign is the object of the work, and the interpretant is the translator sign

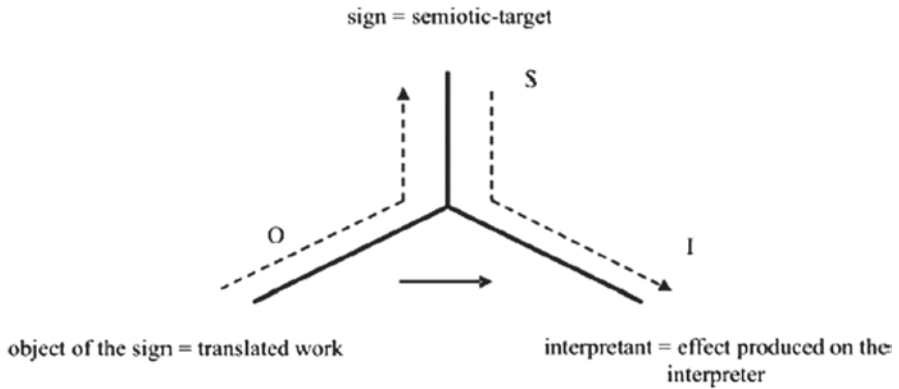

Fig. 7.5 Triadic relation in which the sign is the target, the object of the sign is the translated work, and the interpretant is the interpreter

### 7.6 Intersemiotic Translation of Gertrude Stein

In an effort to better explain the models, we examine an example of IT from literature to dance. In this example, the choreographers Paul Lightfoot and Sol Leon based their work, *Shutters Shut*,<sup>3</sup> for the Nederlands Dans Theater, on the portrait

<sup>3</sup> For more information about the choreography: <http://www.ndt.nl/en/ballets/13>.



“If I Told Him: A Completed Portrait of Picasso” (1923) by Gertrude Stein (2008).

If I told him would he like it. Would he like it if I told him.  
 Would he like it would Napoleon would Napoleon would would he like it.  
 If Napoleon if I told him if I told him if Napoleon. Would he like it if I told him if I told him  
 if Napoleon. Would he like it if Napoleon if Napoleon if I told him. If I told him if Napoleon  
 if Napoleon if I told him. If I told him would he like it would he like it if I told him.  
 Now.  
 Not now.  
 And now.  
 Now.  
 Exactly as as kings.  
 Feeling full for it.  
 Exactitude as kings.  
 So to beseech you as full as for it.  
 Exactly or as kings.  
 Shutters shut and open so do queens. Shutters shut and shutters and so shutters shut and  
 shutters and so and so shutters and so shutters shut and so shutters and shutters and so. And  
 so shutters shut and so and also. And also and so and so and also.  
 Exact resemblance to exact resemblance as exact as resemblance, exactly as resembling,  
 exactly resembling, exactly in resemblance exactly a resemblance, exactly and resem-  
 blance. For this is so. Because.  
 Now actively repeat at all, now actively repeat at all, now actively repeat at all.  
 Have hold and hear, actively repeat at all.  
 I judge judge.  
 As a resemblance to him.  
 Who comes first. Napoleon the first.  
 Who comes too coming coming too, who goes there, as they go the share, who shares all,  
 all is as all as as yet or as yet.  
 Now to date now to date. Now and now and date and the date.  
 Who come first Napoleon the first. Who came first Napoleon the first. Who came first,  
 Napoleon first.  
 [...]

This portrait has multiple interpretations, always connecting Picasso’s personality to formal and semantic aspects of Gertrude’s text. For Régis (2007, p. 55), the portrait “[...] projects a diagram that, little by little, unveils, through the repetition, the quality of a Picasso’s feeling in the presentness of the text, unveiling the rich and active personality of the painter.” The comparison between Picasso and Napoleon is evident, evoking the resemblance of the painter with the former French emperor (see Clüver 1978; Régis 2007; Retallack 2008; Giroud 2007). In *The Autobiography of Alice B. Toklas*, Stein offers a direct comparison:

Picasso was more than ever as Gertrude Stein said the little bullfighter followed by his squadron of four, or as she later in her portrait of him, she called him, Napoleon followed by his four enormous grenadiers. Derain and Braque were great big men, so was Guillaume [Apollinaire] a heavy set man and Salmon was not small. Picasso was every inch a chief. (Stein 1990, p. 62)

However, the most outstanding characteristic of this portrait is the formal construction. It can be compared to Picasso’s cubism, especially *Ma Jolie*, because of its fragmented motifs and metonymic syntax that can form, in Stein’s portrait, grammatically and syntactically correct sentences, but always refusing to yield what the

reader expects (Clüver 1978, p. 27). The repetition and lexical variation, combined with other strategies, create surprising effects, for example, the wordplays or puns, and the unexpected relations between sound and meaning. Beyond that, in this portrait, as in other Stein's texts, the orality can be stressed, because of the importance of the prosody, and the way the rhythm modulates the signification process and the time sense through the reading.

Obviously, there are several ways to translate "If I Told Him..." into dance. In *Shutters Shut*, there are no references to the fact that the text is a portrait of Picasso. There are no attempts to *transcreate* the portrait genre, or to establish any relation to the subject of the portrait. The main relation observed in the translation, based on the most relevant property of this small dance piece, is created between the spoken text and movement vocabulary and dynamic. There is a dance movement for each word, a strategy that could be called a transcription.<sup>4</sup> The audience is able to observe this strategy because the dance duet uses, as its "music," an audio recording of Stein reading her own text. What we have is a kinetic transcription of the text.

The main property of the spoken language translated into dance movements is the prosody. It is related to rhythm, tension, and intonation of the discourse. It can reveal information about the speaker, the kind of vocalization (assertion, question, or imperative proposition), the presence of irony, sarcasm, focus, and elements not codifiable by grammar or vocabulary choices. In acoustic terms, oral language prosody involves syllabic accent, volume, and tone. These properties represent a particular description level, whose *transcreation* into dance should not be neglected, considering the important structural role played by the oral language in Stein. The choreographers Lightfoot and Leon confronted the task of iconically transcreating Gertrude Stein's prosody.

The words "if," "I," and "him," directly correlated with the rhythmic patterns of the portrait because of their repetition and short length, are *transcribed* into quick and angular dance movements. The excerpt "And also and so and so and also," for example, is *transcribed* into a dance movement sequence in which the dancers turn their bodies backward and forward performing quick and wavy dance movements, creating a similar effect of that produced by the repetition when the excerpt is uttered. At different moments of the choreography, it is difficult to distinguish the movements corresponding to each word, which are almost coincident with their subsequent movement. The same happens in the spoken language. The choreography, then, creates a flux *analogous* to the discourse.

According to the first model, the sign-object-interpretant (S-O-I) triad matches the triadic relationship between the portrait (S)—portrait object (O)—dance choreography (I). In our example, the sign is the portrait "If I Told Him: A Completed Portrait of Picasso"; the object is the object of the portrait that, in a very simplified

<sup>4</sup> In the linguistic sense, *transcription* is the systematic representation of the oral language in the written on. In general, transcription and translation are considered distinct phenomena. *Transcription* refers strictly to the passage from spoken language to the written one, involving the transposition of each word. On the other hand, translation, in the strict sense, involves two distinct idioms and the impossibility, by principle, of exact correspondence of all the elements between source and target.

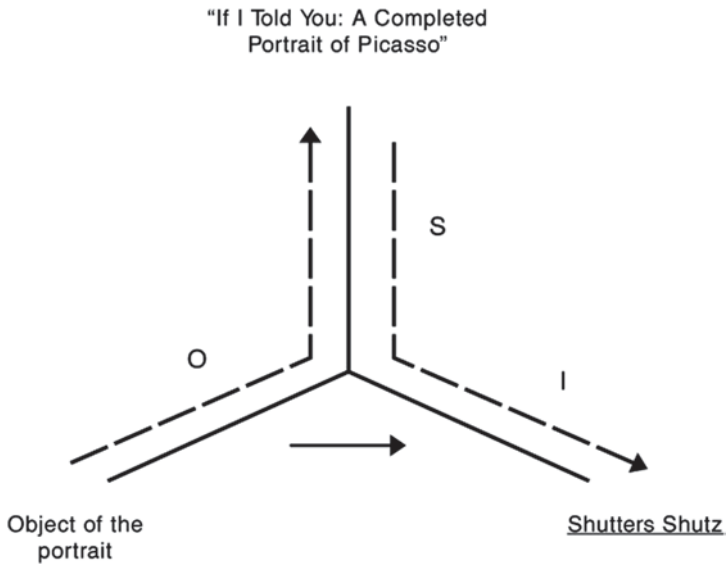

Fig. 7.6 Graphic representation of the first model of the portrait’s translation into *Shutters Shut*

definition, is Picasso’s character and its representation; and the interpretant is the choreography *Shutters Shut* (Fig. 7.6).

According to the second model, the S-O-I triad corresponds to the dance choreography (S)—portrait (O)—the effect on the audience (I). Hence, the sign is the choreography *Shutters Shut*; the object is the portrait “If I Told Him: A Completed Portrait of Picasso,” and the interpretant is the effect of the choreography on its audience (Fig. 7.7).

Therefore, we propose two different modeling possibilities. According to the first, the quality is communicated to the semiotic target (*Shutters Shut*) as a habit embodied in the object of the semiotic source (Picasso’s character). This is very different from our second modeling option, in which the form communicated from the semiotic source (“I If I Told Him...”) to the interpreter (the effect on the audience’s mind) is mediated by the semiotic target (*Shutters Shut*). In this case, semiotic target and semiotic source share some quality. In other words, what is communicated through the semiotic target to the interpreter is a quality shared between the semiotic target and the semiotic source, which is the translated work, not the object of the translated work.

If, as we argue, we are dealing with icons, it should be clear that, in both cases, the interpretant is the effect of an analogy produced by the qualities shared between sign and object. According to the second model of our analysis, the process seems to be more dependent on the intrinsic qualities of source; in the first, it is dependent on the qualities of the object of the source. In the second case, the process seems more dependent on the intrinsic qualities that constitute the source signs; in the first, it is dependent on the qualities that constitute the object of the sign translated.

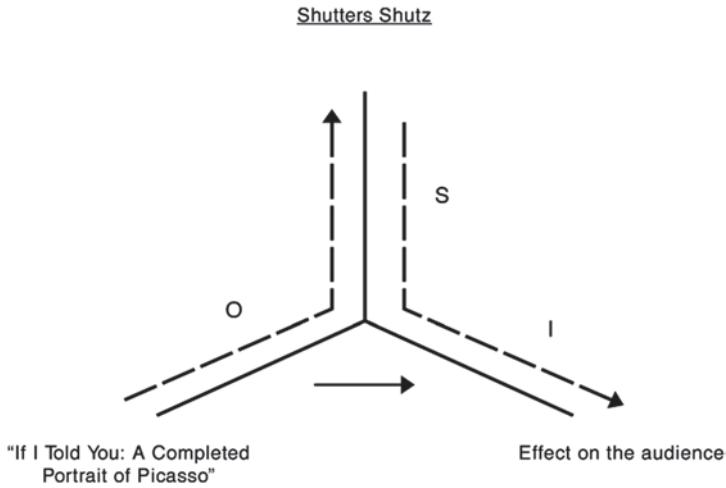

Fig. 7.7 Graphic representation of the second model of the portrait’s translation into *Shutters Shut*

## 7.7 Some Consequences

According to Victoria Welby, semiosis and translation are inseparable phenomena:

In *What is Meaning?*, Welby described translation as “inter-translation,” a method of interpretation and understanding. And given that translative processes are structural to sign processes as they develop across systemic and typological boundaries, and that meaning is generated in the relation among signs, from a signifi- cant perspective, theory of translation and theory of sign and meaning are interconnected. (Petrilli 2009, p. 517)

In another passage: “Translation is therefore no less than a condition for understanding and interpretation of signifying behavior generally [...]” (Petrilli 2009, p. 518). Extending Welby’s claim to IT, an approach of the phenomenon cannot be dissociated from a general theory of signs, which should provide a model of semi- otic processes. Therefore, there are several consequences derived from Peirce’s theory of sign, which are applied to IT.

The comparison between source and target is traditionally treated as a dyadic relation, either in translation studies or in intermediality studies. By applying Peirce’s model of semiosis to describe IT, the phenomenon is observed as essentially triadic, iconic, interpreter, and context dependent.

It is well known that the definition of icon concerns different semiotic systems, locating it far from the tendencies to privilege visual icons. A more controversial fact is that the operational definition of icon extends it beyond the most familiar conception of “similarity” (Stjernfelt 2011). In this sense, when the operational criterion is adopted, the icon is anything that, when manipulated according to certain laws, is able to reveal more information about its object. The fact is that through the operational criterion we can appreciate the discovery status resulting from the manipulation of the “physicality” of the sign. Through that notion, it is possible to infer

that new properties of the object are revealed in both models of IT (see Sect. 7.6). The IT of specific aspects of Stein's portrait, such as prosody, transcreates some properties of the source in a very different material. According to the second model, this process provides, at least hypothetically, the reader or spectator with new information about Stein's portrait through the choreography *Shutters Shut*. According to the first model, however, new information about the object of the portrait is revealed to the target, the choreography, which is the interpretant.

As we saw, the icon predominantly depends on its material. The IT example that we examined, from "If I Told Him..." into *Shutters Shut*, is focused on the materiality of the source sign. The transcreation in diverse materials and systems could "free" the translation task from the primary semantic dimension to which the most current interpretations are attached, forcing the sign source to be revealed in diverse levels and properties.

If, as Haroldo de Campos (2007) argues, a creative translation is the most attentive way of reading a sign system or a text, then an IT can be considered an even more radical practice, since it is obliged to transcreate the same effects produced by the source using drastically different systems and materials. IT represents a domain of new language processes and invention because it tends to produce different habits of sign manipulation and interpretation. This idea deserves an even more accurate development. In our argument, IT could represent a laboratory of experimentation involving new ways to deal with well-known materials and methods, since it requires from the translator or translation team a selective attention to the relations between the levels of description of the source sign, as well as the most relevant aspects in these relations.

**Acknowledgments** Daniella Aguiar would like to acknowledge the support received, in the form of research grant, from CAPES Foundation, the Ministry of Education of Brazil, Brasília—DF 70040-020, Brazil (postdoctoral studies grant).

## References

- Aguiar, Daniella, and João Queiroz. 2009. Towards a model of intersemiotic translation. *International Journal of the Arts in Society* 4:203–210.
- Aguiar, Daniella, and João Queiroz. 2010. Modeling intersemiotic translation: Notes toward a Peircean approach. *AS/SA* 9 (24): 68–81, <http://french.chass.utoronto.ca/as-sa/ASSA-No24/Article6en.htm>. Accessed 02 Jan 2012.
- Aguiar, Daniella, and João Queiroz. 2011a. Hypoicons in intersemiotic translation. Paper presented at the Eighth International Symposium on Iconicity in Language and Literature, Linnaeus University, 16–18 June.
- Aguiar, Daniella, and João Queiroz. 2011b. The dance of Gertrude Stein: Images, diagrams, and metaphors in intersemiotic translation. Paper presented at the Sixth International Conference on the Arts in Society, Berlin-Brandenburg Academy of Sciences and Humanities, 9–11 May.
- Aguiar, Daniella, and João Queiroz. 2013. Semiosis and intersemiotic translation. *Semiotica* 196:283–292.

- Atkin, Albert. 2010. Peirce's theory of signs. In *The Stanford encyclopedia of philosophy*, ed. Edward N. Zalta. <http://plato.stanford.edu/archives/sum2013/entries/peirce-semiotics/>. Accessed 13 Sept 2013.
- Campos Haroldo de. 1992. Da tradução como criação e como crítica. In *Metalinguagem e outras metas: ensaios de teoria e crítica literária*, ed. Haroldo de Campos, 31–48. São Paulo: Perspectiva.
- Campos Haroldo de. 1997. *O Arco-íris Branco*. São Paulo: Imago.
- Campos Haroldo de. 2007. Translation as creation and criticism. In *Novas-selected writings Haroldo de Campos*, eds. Odile Cisneros and Antonio Sergio Bessa, 312–326. Northwestern University Press.
- Clüver, Claus. 1978. Painting into poetry. *Yearbook of Comparative and General Literature* 27:19–34.
- Damiani, Matteo. 2008. La contribución de la Semiótica a la traducción interlingüística. *Tonos Revista Electrónica de Estudios Filológicos* 15.
- De Tienne, André. 1992. Peirce's semiotic monism. In *Signs of Humanity/L'homme et ses signes. (=Approaches to Semiotics. 107)*, eds. G. Deledalle, M. Balat and J. Deledalle Rhodes, 1291–1303. Berlin: Mouton de Gruyter.
- Eco, Umberto. 2007. *Quase a Mesma Coisa*. Rio de Janeiro: Record.
- Fabbrichesi, Rossella. 2011. Iconic thought and diagrammatical scripture: Peirce and the leibnizian tradition. *Semiotica* 186:111–127.
- Giroud, Vincent. 2007. Picasso and gertrude stein. *The Metropolitan Museum of Art Bulletin-New Series* 64 (3): 1–4.
- Gorlée, Dinda. 1994. *Semiotics and the problem of translation, with special reference to the semiotics of Charles S. Peirce*. Amsterdam: Rodopi.
- Gorlée, Dinda. 2005. Singing on the breath of God. In *Song and significance: Virtues and vices of vocal translation*, ed. Dinda L. Gorlée, 17–102. Amsterdam: Rodopi.
- Gorlée, Dinda. 2007. Bending back and breaking. *Symploke* 15 (1–2): 341–352.
- Hausman, C. R. 1993. *Charles S. Peirce's evolutionary philosophy*. Cambridge: Cambridge University Press.
- Hodgson, Robert. 2007. Semiotics and Bible translation. *Semiotica* 163 (1/4): 37–53.
- Hookway, Christopher. 1985. Peirce. Routledge & Kegan Paul.
- Hookway, Christopher. 2000. *Truth, rationality, and pragmatism: Themes from Peirce*. Oxford: Oxford University Press.
- Houser, Nathan, Don Roberts, James van Evra, eds. 1997. *Studies in the logic of Charles Sanders Peirce*. Bloomington: Indiana University Press.
- Jakobson, Roman. 1980. Poetry of grammar and grammar of poetry: (Excerpts). *Poetics Today* 2 (1a): 83–85.
- Jakobson, Roman. 2000. On linguistic aspects of translation. In *The Translation Studies Reader*, ed. Lawrence Venuti, 113–118. London: Routledge.
- Jakobson, Roman, and Kristina Pomorska. 1985. *Diálogos*. São Paulo: Cultrix.
- Jeha, Julio. 1997. Intersemiotic translation: The Peircean basis. In Fifth Congress of the International Association for Semiotic Studies. *Semiotics in the World: Synthesis in Diversity. Berkeley* 1:639–642.
- Morris, Charles. 1971. *Writings on the general theory of signs*. The Hague: Mouton.
- Murphey, M. G. 1993. *The Development of Peirce's philosophy*. Cambridge: Cambridge University Press.
- Peirce, Charles S. 1992/1998. *The essential Peirce, selected philosophical writings*. (Vol. 1 ed. by N. Houser & C. Kloesel; Vol 2 ed. by the Peirce Edition Project). Bloomington and Indianapolis: Indiana University Press, EP1 1992, EP2 1998. (Quoted as EP).
- Peirce, Charles S. 1931–1935. *The collected papers of Charles Sanders Peirce*. Electronic edition reproducing Vols. eds. I–VI [C. Hartshorne, and P. Weiss, Cambridge: Harvard University Press, 1931–1935]; Vols. VII–VIII [A. W. Burks (ed.), same publisher, 1958]. Charlottesville: Intelix Corporation, 1931–1935. (Quoted as CP).

- Peirce, Charles S. 1967. *Annotated catalogue the papers of Charles S. Peirce*. (ed.) R.S. Robin. Massachusetts: The University of Massachusetts Press. (Quoted as MS).
- Petrilli, Susan. 2009. *Signifying and understanding: Reading the works of Victoria Welby and the signific movement*. Berlin: De Gruyter Mouton.
- Petrilli, Susan, and Augusto Ponzio. 2010. Iconic features of translation. *AS/SA* 9 (24): 32–53, <http://french.chass.utoronto.ca/as-sa/ASSA-No24/Article4en.html>. Accessed 02 Jan 2012.
- Plaza, Julio. 1987. *Tradução Intersemiótica*. São Paulo: Perspectiva.
- Queiroz, João. 2010. Tradução criativa, diagrama e cálculo icônico. *Alea: Estudos Neolatinos* 12:322–332.
- Queiroz, João, and Charbel El-Hani. 2006. Semiosis as an emergent process. *Transaction of C.S. Peirce Society* 42 (1): 78–116.
- Queiroz, João, and Daniella Aguiar. 2013. Iconicity and intersemiotic translation. In *Writing, voice, undertaking*, ed. Petrilli Susan, 29–32. New York: LEGAS.
- Queiroz, João, and Floyd Merrell. 2009. On Peirce's pragmatic notion of semiosis—a contribution for the design of meaning machines. *Minds & Machines* 19:129–143.
- Régis, Sônia. 2007. Paris foi uma festa (Gertrude Stein). In RÉGIS, Sônia. *Aproximações: Ensaio sobre literatura*. Creative Commons. 50–57.
- Retallack, Joan. 2008. Introduction. In: *Gertrude stein: Selections*, ed. Joan Retallack, 3–81. Berkeley: University of California Press.
- Savan, David. 1987–1988. *An Introduction to C.S. Peirce's Full System of Semeiotic*. Toronto: Monograph Series of Toronto Semiotic Circle.
- Steconni, Umberto. 2004. Interpretive semiotics and translation theory: The semiotic conditions to translation. *Semiotica* 150 (1–4): 471–489.
- Stein, Gertrude. 2008. If I told him: A completed portrait of Picasso. In: *Gertrude stein: Selections*, ed. Joan Retallack, 190–193. Berkeley: University of California Press.
- Stein, Gertrude. 1990. *The autobiography of Alice B. Toklas*. Vintage.
- Stjernfelt, Frederik. 2011. On operational and optimal iconicity in Peirce's diagrammatology. *Semiotica* 186:395–419.
- Stjernfelt, Frederik. 2000. Diagrams as centerpiece of a Peircean epistemology. *Transactions of C.S. Peirce Society* 36 (3): 357–384.
- Zeman, Jay. 1977. The esthetic sign in Peirce's semiotic. *Semiotica* 19 (3/4): 241–258.

**João Queiroz** ([www.semiotics.pro.br](http://www.semiotics.pro.br)) is a professor at the Institute of Arts and Design, Federal University of Juiz de Fora, Minas Gerais, Brazil. He earned a PhD in communication and semiotics from the Catholic University of São Paulo (PUC-SP), and received a postdoctoral fellowship in intelligent systems at the School of Electrical and Computer Engineering (FEEC-DCA), State University of Campinas (UNICAMP). His research interests include: Peirce's philosophy and semiotics, biosemiotics, cognitive science, as well as South American and Brazilian literature.

**Daniella Aguiar** (<http://daniellaguaiar.wordpress.com/>) is a postdoc researcher at the Graduate Studies Program in Literature Studies at the Federal University of Juiz de Fora (UFJF), Brazil. She obtained a bachelor degree in dance at Anhembi Morumbi University, São Paulo; a master degree in dance at the Graduate Studies Program in Dance at the Federal University of Bahia (UFBA); a PhD in Comparative Literature at the Graduate Program in Literature at the State University of Rio de Janeiro (UERJ). Her main research interests are dance and other arts, dance theory, intermediality, and Peirce's semiotics.