

 Open access • Journal Article • DOI:10.1002/JEZ.1402650404

## **Ca<sup>2+</sup> and Mg<sup>2+</sup> transport in gills and gut of tilapia, *Oreochromis mossambicus* : a review** — [Source link](#)

G. Flik, G. Flik, [Joan A. Van Der Velden](#), [Joan A. Van Der Velden](#) ...+10 more authors

**Institutions:** [Delft University of Technology](#), [Radboud University Nijmegen](#)

**Published on:** 15 Mar 1993 - [Journal of Experimental Zoology](#) (Wiley Subscription Services, Inc., A Wiley Company)

**Topics:** [Plasma membrane Ca<sup>2+</sup> ATPase](#), [Calcium pump](#), [Basolateral plasma membrane](#), [Paracellular transport and Apical membrane](#)

Related papers:

- [Characterization of branchial transepithelial calcium fluxes in freshwater trout, \*Salmo gairdneri\*](#)
- [The movement of cadmium through freshwater trout branchial epithelium and its interference with calcium transport](#)
- [Calcium transport in fish gills and intestine](#)
- [Kinetics of Branchial Calcium Uptake in the Rainbow Trout: Effects of Acclimation to Various External Calcium Levels](#)
- [Calcium uptake in the skin of a freshwater teleost.](#)

Share this paper:    

View more about this paper here: <https://typeset.io/papers/ca2-and-mg2-transport-in-gills-and-gut-of-tilapia-pdo7730d9x>

## PDF hosted at the Radboud Repository of the Radboud University Nijmegen

The following full text is a publisher's version.

For additional information about this publication click this link.

<http://hdl.handle.net/2066/16682>

Please be advised that this information was generated on 2022-05-30 and may be subject to change.

## Ca<sup>2+</sup> and Mg<sup>2+</sup> Transport in Gills and Gut of Tilapia, *Oreochromis mossambicus*: A Review

GERT FLIK, JOAN A. VAN DER VELDEN, KOEN J. DECHERING,  
PIETER M. VERBOST, THEO J.M. SCHOENMAKERS,  
ZVONIMIR I. KOLAR, AND SJOERD E. WENDELAAR BONGA

*Department of Animal Physiology, Faculty of Science, University of Nijmegen,  
6525 ED Nijmegen, The Netherlands and Department of Radiochemistry,  
Interfaculty Reactor Institute, Delft University of Technology, 2629 JB Delft,  
The Netherlands*

**ABSTRACT** The euryhaline tilapia *Oreochromis mossambicus* kept in fresh water takes up calcium mainly from the water via the gills, like other freshwater fish. In the gills specialized mitochondria-rich cells, the chloride cells, are thought to mediate a transcellular Ca<sup>2+</sup> transport. Second messenger operated calcium channels (SMOCs) in the apical membrane, regulated by the hormone stanniocalcin, allow minute-to-minute control over the entry of Ca<sup>2+</sup>. In the basolateral plasma membranes of these cells, an ATP-consuming Ca<sup>2+</sup> transporting enzyme provides the major driving force for extrusion of Ca<sup>2+</sup> into the blood; in addition, an Na<sup>+</sup>/Ca<sup>2+</sup> exchanger is present in these membranes. The kinetics of the exchanger in vitro indicate that this extrusion mechanism dominates when intracellular calcium levels reach micromolar levels. In the gills, the transport of calcium appears primarily ATPase mediated and therefore largely independent of the Na<sup>+</sup> status of the transporting cell. In enterocytes, similar mechanisms for transcellular transport of Ca<sup>2+</sup> exist. However, in the intestinal epithelium the extrusion of Ca<sup>2+</sup> is primarily via the Na<sup>+</sup>/Ca<sup>2+</sup> exchanger and to a very limited extent mediated via the Ca<sup>2+</sup>-ATPase. Indeed, calcium transport over the intestinal epithelium is dependent on the Na<sup>+</sup>-status and the Na<sup>+</sup>/K<sup>+</sup>-ATPase activity of the epithelium. Prolactin and cortisol are endocrine factors determining the relative densities of calcium pumps in basolateral plasma membranes.

At least 80% of the magnesium required for growth and homeostasis is absorbed from the food via the intestine. Magnesium is transported transcellularly and actively via enterocytes. The movement of Mg<sup>2+</sup> over the apical membrane is passive, down an electrochemical gradient. The cytosolic Mg<sup>2+</sup> concentration is kept well below its equilibrium concentration. The extrusion over the basolateral plasma membrane is mediated by an ATP-consuming enzyme. The gills contribute less than 20% to magnesium uptake, but up to 50% in tilapia fed a magnesium deficient diet. Evidence is accruing that prolactin is involved in the adaptation to low magnesium diets. © 1993 Wiley-Liss, Inc.

Our laboratories have conducted studies pertaining to calcium and magnesium transport mechanisms in fish gills and intestinal epithelium. This is a review of published studies and recent unpublished findings resulting from this work. It is not an exhaustive review; rather, data sets on tilapia research (some still incomplete) are presented to stimulate discussion.

### CALCIUM TRANSPORT

#### *Gills*

In the euryhaline teleost tilapia *Oreochromis mossambicus* kept in fresh water, the gills are the major site for exchange of calcium with the water (Filk et al., '85a). In growing freshwater tilapia, influx of calcium always exceeds the efflux, result-

ing in a positive calcium balance to augment the total body calcium pool (Flik et al., '86a,b). Modulation of branchial calcium fluxes in response to particular environmental water conditions (e.g., variations in calcium concentrations) is therefore a prerequisite for calcium homeostasis. Consequently, the dominant calcitropic hormones in fish (stanniocalcin, prolactin, and cortisol; see below) exert major effects on the gills.

Only recently have the mechanisms underlying the unidirectional fluxes of calcium through the branchial epithelium been elucidated. Calcium taken up from the water in freshwater fish follows a transcellular, hormone-controlled pathway located in the chloride cells of the gills. In a model for transcellular Ca<sup>2+</sup> transport (Fig. 1) based on our studies on trout, eel, and tilapia, stanniocalcin (STC)

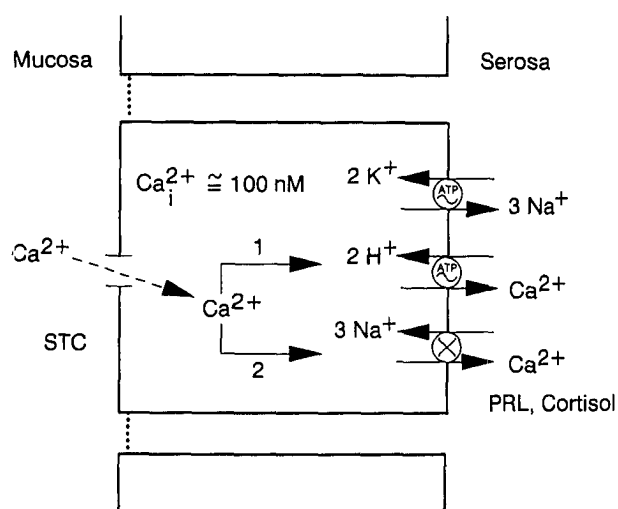

Fig. 1. Model for transcellular  $\text{Ca}^{2+}$  transport in tilapia gills and intestine. Mucosal  $\text{Ca}^{2+}$ , from the water or the food, may enter the cell passively, down an electrochemical gradient. Stanniocalcin (STC) regulates calcium channels in the apical membrane; STC signal transduction requires second (cAMP, DAG,  $\text{IP}_3$ ) and third ( $\text{Ca}^{2+}$ ) messengers. Extrusion of  $\text{Ca}^{2+}$  from the cell is either via a  $\text{Ca}^{2+}$ -ATPase (route 1) or via an  $\text{Na}^+/\text{Ca}^{2+}$  exchanger (route 2). Both extrusion mechanisms are present in branchial and intestinal epithelium. In gill cells route 1 dominates, in the enterocyte route 2. In the enterocyte, very high  $\text{Na}^+/\text{K}^+$ -ATPase activity safeguards the operation of the exchanger by maintaining the  $\text{Na}^+$  gradient as a driving force for the exchanger. The calcitropic hormones cortisol and prolactin (PRL) determine the relative abundance of the ATPases, and by doing so determine the calcium transporting capacity of the epithelium.

controls the apical membrane transition of  $\text{Ca}^{2+}$  (Lafeber et al., '88; Flik, '90), while cortisol (Flik and Perry, '89) and prolactin (Flik et al., '84b, '86c, '89a) influence the enzymic makeup of the basolateral plasma membrane. The latter two hormones increase the  $\text{Ca}^{2+}$ -ATPase density, and by doing so determine the calcium pumping capacity of the chloride cells and hence of the branchial epithelium. STC is a fast-acting hormone inhibiting calcium influx within minutes (Lafeber et al., '88). Cortisol and prolactin effects on the epithelium become clear only after several days, suggesting that new cells have developed stimulated by a particular hormonal status of the animal. This status in turn represents the adaptive response of the fish to the changed environment.

#### $\text{Ca}^{2+}$ entry over the apical membrane

STC is a homodimeric glycoprotein of 56 (in most fish studied) to 60 (in eel) kilodalton from the corpuscles of Stannius (Flik et al., '89b, '90a). Physiological studies have provided circumstantial evidence that STC is the major hypocalcemic hormone in fish exerting the minute-to-minute con-

trol over apical membrane  $\text{Ca}^{2+}$  transport. In a trout, isolated head preparation STC inhibits  $\text{Ca}^{2+}$  influx within 15 min (Lafeber et al., '88). STC also inhibits  $^{45}\text{Ca}^{2+}$  uptake from the water into branchial epithelium (Verboost et al., '89). These observations are in line with a conclusion reached earlier that the apical  $\text{Ca}^{2+}$  translocation is passive, down an electrochemical gradient through voltage-independent calcium channels (Perry and Flik, '88). Removal of the corpuscles of Stannius (rapidly) evokes a patent hypercalcemia (Hanssen et al., '89) and the severity of the hypercalcemia is positively correlated with the water calcium level (Flik, '90). These observations all indicate that  $\text{Ca}^{2+}$  from the water enters the  $\text{Ca}^{2+}$  transporting cell via an STC-controlled pathway located in the apical membrane.

We postulate that the receptors for STC are localized in the basolateral plasma membrane. Subsequently, second and third messengers transduce the STC signal to the apical membrane; this is the reasoning behind the postulate of second messenger operated calcium channels (SMOCs). An extract of trout corpuscles of Stannius lowers the branchial cAMP content and inhibits adenylate cyclase in branchial (and in renal and intestinal) plasma membranes (Flik, '90). These results suggested that cAMP is involved as a second messenger in the STC signal transduction. However, recent studies have revealed that an extract of corpuscles of Stannius contains two bioactive components, STC and a small glycoprotein which we tentatively equate with teleocalcin, first reported on by Ma and Copp ('78). It turned out that the "cAMP-effects" in an extract of the corpuscles of Stannius must be attributed to the teleocalcin activity in the extract. This effect on cAMP levels, however, is unrelated to the direct regulation of the calcium influx, as pure teleocalcin has no effect on calcium influx (P.M. Verboost, personal communication). It is our strong belief that inositol metabolites are involved in the messenger pathway of STC. The impetus for this statement was the observation that STC stimulated the production of *sn*-1,2-diacylglycerol (DAG) in tilapia branchial cells (Fig. 2). DAG is one of the second messengers released in a cell when the inositol cycle is stimulated. Studies on the effects of STC on the production of inositol metabolites are now being carried out. One would predict that  $\text{IP}_3$ , the other second messenger produced when inositol metabolism is stimulated, is produced in the branchial cells after stimulation with STC. It is usually found in this field of research that  $\text{IP}_3$  levels are low and difficult to establish. In line with our prediction is the observation that in permeabilized gill cells  $\text{IP}_3$  stim-

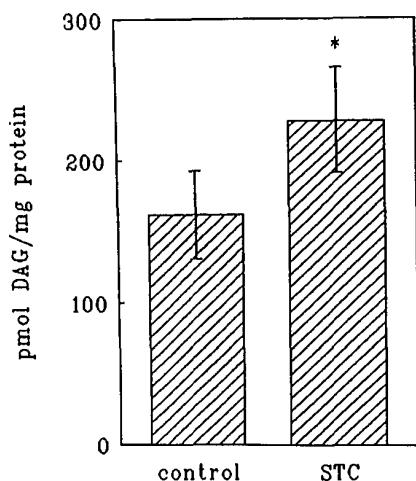

Fig. 2. Stanniocalcin (STC) stimulation of *sn*-1,2-diacylglycerol (DAG) production in freshwater tilapia gill cells. DAG was determined with a commercial radioenzymatic assay kit (RPN200, Amersham). Mean values  $\pm$  SEM for six fish are given. The asterisk indicates significance of the difference compared to the control ( $P < 0.03$ ; Mann-Whitney *U*-test).

ulates  $\text{Ca}^{2+}$  (third messenger) release from endoplasmic reticular stores (Fig. 3). Thus, although  $\text{IP}_3$  production per se as a response to an STC stimulus still has to be established, the presence of an  $\text{IP}_3$  receptor in the endoplasmic reticulum of gill cells seems evident.

The overall picture emerging so far is that STC evokes in its targets second and third messenger responses, which are tentatively related to the control of the apical membrane  $\text{Ca}^{2+}$  channel: the time course of the STC inhibition of the branchial  $\text{Ca}^{2+}$  influx (significant effects within 15 min) is in accordance with the rapid second messenger responses observed (effects within 10 min). Phosphorylation studies with highly purified apical, i.e., brush border, preparations of intestinal and renal tissue may ultimately give more direct evidence for  $\text{Ca}^{2+}$  mediated modulatory actions of STC on SMOCs in these cells. Branchial apical membranes are difficult to isolate, however.

#### ***Ca<sup>2+</sup> extrusion in the basolateral plasma membrane***

Two mechanisms for  $\text{Ca}^{2+}$  extrusion exist in the basolateral plasma membrane of branchial epithelium. The first, a high-affinity  $\text{Ca}^{2+}$ -ATPase, represents the ATP-driven calcium pump and is well documented (Flik et al., '84a, '85a,b; Perry and Flik, '88). The second is an  $\text{Na}^+/\text{Ca}^{2+}$  exchange mechanism (Figs. 4 and 5a). We present here for the first time evidence for its presence in branchial epithelial plasma membranes.

ATP-driven  $\text{Ca}^{2+}$  transport and  $\text{Na}^+/\text{Ca}^{2+}$  exchange activity were analyzed in the same plasma membrane preparation. The methodology for determining  $\text{Ca}^{2+}$ -ATPase mediated  $\text{Ca}^{2+}$  transport in plasma membrane vesicles (determined as the difference in  $^{45}\text{Ca}^{2+}$  accumulation in the presence and absence of ATP) has been described extensively in the references given; that for  $\text{Na}^+/\text{Ca}^{2+}$  exchange will be briefly described below. The kinetics of the  $\text{Ca}^{2+}$  pump (for tilapia we found a  $K_{0.5}$  of  $102 \pm 46$  nM  $\text{Ca}^{2+}$  and a  $V_{\text{max}}$  of  $3.79$  nmol  $\times$  min<sup>-1</sup> per mg protein;  $n = 6$ ) suggest that this enzyme operates in the extrusion process (Flik et al., '85a). Typically, the enzyme is stimulated in vitro at calcium levels that are found at rest in most cells (around 100 nM) and the maximum  $\text{Ca}^{2+}$  transport capacity of the gills derived from the  $V_{\text{max}}$  (Flik et al., '85a) is realistic when compared to the  $\text{Ca}^{2+}$  influx that is observed in the gills. In addition to thermodynamic arguments (Perry and Flik, '88), further evidence for a role of the ATP-driven calcium pump in transepithelial transport comes from endocrinological studies. Hypercalcemic hormones, viz. cortisol in trout (Flik and Perry, '89) and prolactin in eel (Flik et al., '84b, '89a) and tilapia (Flik et al., '86c), stimulate  $\text{Ca}^{2+}$  influx via the gills and increase the density of the calcium pumps in the basolateral plasma membranes.

Characteristic changes in branchial epithelial plasma membranes observed by us after treatment of the fish with prolactin or cortisol are a higher activity of  $\text{Ca}^{2+}$ -ATPase relative to  $\text{Na}^+/\text{K}^+$ -ATPase and an increased  $V_{\text{max}}$  of the calcium pumps in basolateral plasma membrane vesicles. Based on the rapid turnover of chloride cells in the gills (Wendelaar Bonga et al., '90), it is our strong belief that cortisol and prolactin administration for 4–8 days (the time period required to evoke hypercalcemic responses) results in the development of a new population of chloride cells that reflect the particular hormonal status.

The first indication for  $\text{Na}^+/\text{Ca}^{2+}$  exchange activity in branchial epithelial plasma membranes came from an experiment in which  $\text{Ca}^{2+}$  transporting vesicles (ATP-dependent transport at  $1 \mu\text{M}$   $\text{Ca}^{2+}$  in the medium) were challenged after 10 min of calcium loading with 70 mM NaCl or KCl (control). The inwardly directed  $\text{Na}^+$  gradient thus created drives out  $^{45}\text{Ca}^{2+}$  accumulated in the vesicles as a result of the ATPase activity. The loss of  $^{45}\text{Ca}^{2+}$  seen when KCl is added to the medium is assumed to result from an osmotic effect. Significantly greater loss of  $^{45}\text{Ca}^{2+}$  occurred at 1 and 5 min after addition of NaCl compared to KCl (Fig. 4).

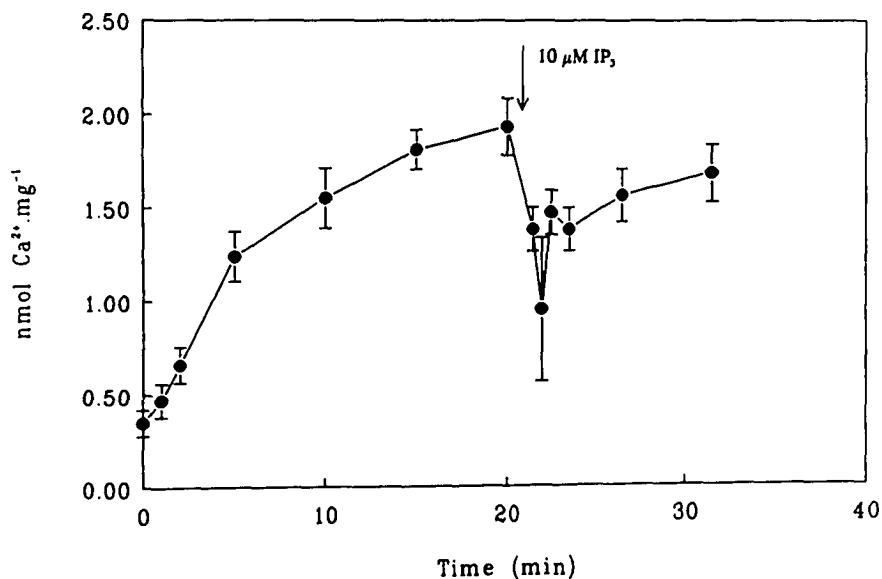

Fig. 3.  $\text{IP}_3$  induced  $\text{Ca}^{2+}$  release in freshwater tilapia permeabilized gill cells. Isolated gill cells were permeabilized with saponin.  $^{45}\text{Ca}^{2+}$  uptake was assayed in a Leibowitz medium supplemented with 3 mM ATP, 667 MBq/ml  $^{45}\text{CaCl}_2$  (Amersham), and a calculated  $0.1 \mu\text{M}$   $\text{Ca}^{2+}$ , using an EGTA/NTA/HEEDTA buffer system (Flik et al., '90b). After the  $^{45}\text{Ca}^{2+}$  uptake had reached a plateau, inositol (1,4,5) trisphosphate (Calbiochem) was added to a final concentration of  $10 \mu\text{M}$ . Control experi-

ments included the omission of ATP and the addition of oxalate and vanadate in the presence of ATP (data not shown). The addition of  $\text{IP}_3$  (arrow) results in the release of  $\text{Ca}^{2+}$  out of a compartment that is oxalate-permeable and equipped with a vanadate-inhibitable  $\text{Ca}^{2+}$  pump with high affinity for  $\text{Ca}^{2+}$  (the endoplasmic reticulum). Values  $\pm$  SEM are given for 6 fish. Release of  $\text{Ca}^{2+}$  occurred in all cases.

We then further investigated the calcium kinetics of this presumed exchange activity as follows.  $\text{Na}^+$ -dependent  $\text{Ca}^{2+}$  transport across plasma membranes was assayed as the difference in  $^{45}\text{Ca}^{2+}$  accumulation upon transfer of membrane vesicles equilibrated in 150 mM NaCl to media containing either 150 mM NaCl (blank) or 150 mM KCl. In composing the media, a 25-fold dilution of the vesicle suspension was taken into account to yield the following final concentrations: 150 mM NaCl or KCl, 20 mM HEPES/Tris (pH 7.4), 0.5 mM EGTA, 0.5 mM HEEDTA, 0.5 mM NTA, 0.8 mM free  $\text{Mg}^{2+}$ , and  $7.5 \times 10^{-5}$  to  $5 \times 10^{-2}$  mM free  $\text{Ca}^{2+}$ . Free  $\text{Ca}^{2+}$  and  $\text{Mg}^{2+}$  concentrations were calculated as described in detail recently (Schoenmakers et al., '92b). The  $^{45}\text{Ca}$  radioactive concentration was 0.5 to 0.8 MBq  $\times$  ml<sup>-1</sup>. A 5  $\mu\text{l}$  vesicle suspension was mixed with 120  $\mu\text{l}$  medium, both prewarmed to 37°C. After 5 sec of incubation, the reaction was quenched by addition of 1 ml ice-cold stopbuffer (150 mM NaCl, 20 mM HEPES/Tris at pH 7.4, 1.0 mM  $\text{LaCl}_3$ ) to the incubate. Membrane vesicles with retained  $^{45}\text{Ca}$  were collected by filtration over 0.45  $\mu\text{m}$  filters (Schleicher & Schüll, ME 25); the filters were washed twice with 2 ml stopbuffer. The filters were dissolved in the scintillation fluid (Aqualuma<sup>r</sup>, Lumac) and the radioactivity collected on the filters was determined by liquid scintillation counting. We first analyzed the

$\text{Ca}^{2+}$  dependence of the exchanger to allow an evaluation of the relative activities of the ATPase and the exchanger in the membrane as a function of the (cytosolic) calcium concentration. The exchange activity showed saturation and was well described by Michaelis-Menten kinetics; the kinetic parameters derived are a  $V_{\text{max}}$  of  $19.6 \pm 2.7 \text{ nmol} \times \text{min}^{-1}$  per mg protein and a  $K_{0.5}$  of  $1.95 \pm 0.45 \mu\text{M}$  (Fig. 5a). Clearly, the exchange activity in the gills is a powerful mechanism for  $\text{Ca}^{2+}$  transport, especially when cytosolic calcium concentrations exceed  $1 \mu\text{M}$  (see discussion below; Fig. 6a).

The regulation of the  $\text{Na}^+/\text{Ca}^{2+}$  exchanger activity in the gills has, until now, not received attention in our research. Studies on the effects of seawater adaptation of tilapia on the exchanger and its sodium dependence are in progress; effects of prolactin(s) and growth hormone on plasma membrane  $\text{Na}^+/\text{K}^+$ -ATPase (on which the exchanger depends) will be reevaluated in this respect.

What, then, is the role of the  $\text{Na}^+/\text{Ca}^{2+}$  exchanger in the calcium homeostasis of the branchial cells? We have plotted the activities of the two plasma membrane calcium extrusion mechanisms as a function of cytosolic calcium levels (Fig. 6a). For the exchange activity, it was assumed that the  $\text{Na}^+$  gradient was not limiting its activity. At cytosolic  $\text{Ca}^{2+}$  concentrations up to  $1 \mu\text{M}$ , the  $\text{Ca}^{2+}$ -ATPase

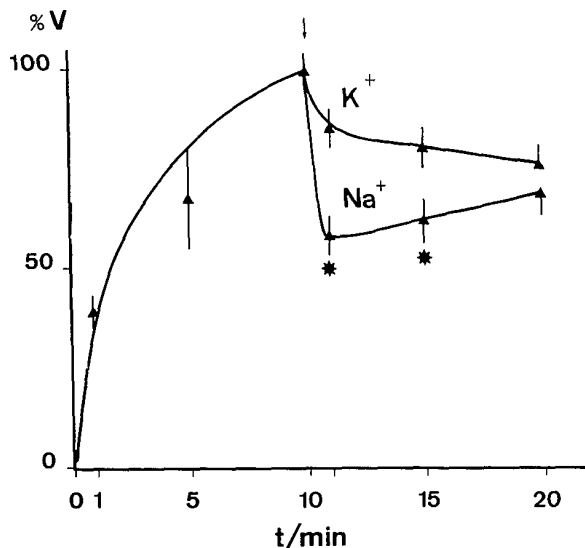

Fig. 4. Effects of the addition of  $\text{Na}^+$  or  $\text{K}^+$  (70 mM, indicated by the arrow) on the ATP-driven uptake of  $^{45}\text{Ca}^{2+}$  into branchial plasma membrane vesicles (5 mM ATP, 1  $\mu\text{M}$   $\text{Ca}^{2+}$ ). The ATP-driven  $\text{Ca}^{2+}$  uptake at 10 min was put to 100%. The addition of  $\text{Na}^+$  reduces vesicular  $^{45}\text{Ca}$  significantly (asterisk:  $P < 0.01$ ,  $n = 6$ ; Mann-Whitney  $U$ -test) compared to when  $\text{K}^+$  is added. Apparently the inwardly directed  $\text{Na}^+$  gradient drives out  $^{45}\text{Ca}^{2+}$  pumped into the vesicles by the ATPase. The presence of an  $\text{Na}^+/\text{Ca}^{2+}$  exchanger in these vesicles seems therefore indicated.

mediated transport exceeds that of the exchanger. When  $\text{Ca}^{2+}$  concentrations in the cytosol exceed 1  $\mu\text{M}$  the exchanger may become increasingly important for the export of  $\text{Ca}^{2+}$  from the cell. The hypothesis to test now is that  $\text{Ca}^{2+}$  uptake via the gills is largely independent of  $\text{Na}^+$ , when the principal  $\text{Ca}^{2+}$  extrusion mechanism therein is  $\text{Na}^+$ -independent (Fig. 1, route 1).

### Intestine

The role of intestinal absorption of  $\text{Ca}^{2+}$  in the calcium metabolism of freshwater fish is not always clear. Feeding freshwater fish a calcium-free diet does not hamper growth or affect calcium homeostasis, provided that  $\text{Ca}^{2+}$  may be absorbed directly from the water via the gills. However, in times of extreme needs for calcium, e.g., during gonadal maturation or during growth spurts, intestinal absorption of calcium may become important. The fact that fish require vitamin D for normal calcium and phosphate homeostasis further extends this notion, as vitamin D was shown to stimulate intestinal calcium absorption in the eel (Fenwick et al., '84). Moreover, we have never been able to show effects of vitamin D (or its analogs) on branchial calcium handling (G. Flik and J.C. Fenwick, unpublished).

There is limited data available on effects of calcitropic hormones on the intestine of fish. Takagi and coworkers ('85) successfully removed corpuscles of Stannius from trout and showed effect on intestinal calcium transport. Studies by Hirano ('89) have given evidence that STC in the eel controls the passive entry of calcium into the intestinal epithelium. In our lab we have shown that an extract of corpuscles of Stannius inhibits plasma membrane adenylate cyclase in tilapia enterocytes (Flik, '90), but this effect is likely to be attributed to the teleocalcin present in this preparation. However, recently we have been able to show a consistent stimulation by STC of  $\text{IP}_3$  production in tilapia enterocytes (P.M. Verboost, personal communication). Thus the enterocyte is a likely STC target and the presence of SMOCs in this cell should be further studied. For prolactin effects on the intestine of tilapia, indirect evidence was advanced (Flik et al., '86c): ovine prolactin reduces calcium loss via intestinal (and renal) routes.

One of the aims of our present research is to fill in the model of the endocrine regulation of  $\text{Ca}^{2+}$  transport in the enterocyte in analogy to the chloride cell of the gills. The intestinal epithelium has some important advantages over the branchial epithelium to make it an attractive model. The tilapia intestinal epithelium is easily stripped of its submucosa and was successfully used in an Ussing chamber setup (Flik et al., '90b; Van der Velden et al., '90). Furthermore, the epithelium is rather homogeneous as it contains no crypts. In biochemical studies, the enterocyte is easily fractionated to allow the isolation of brush border membranes (STC dependent SMOCs) and basolateral membranes (vitamin D and prolactin dependent extrusion mechanisms). We analyzed the calcium transport phenomena described here for the gills (earlier) in the intestine of the tilapia (Flik et al., '90b) and found some remarkable differences between these tissues. Cell mediated calcium transport in the intestine is dependent on the sodium status of the epithelium and it is  $\text{Na}^+/\text{K}^+$ -ATPase-dependent, as indicated by its sensitivity to ouabain. We subsequently analyzed the basolateral plasma membranes for  $\text{Ca}^{2+}$ -ATPase and  $\text{Na}^+/\text{Ca}^{2+}$  exchange activities. First we found an extremely low  $\text{Ca}^{2+}$ -ATPase mediated calcium transport in plasma membrane vesicles ( $K_{0.5} = 27$  nM;  $V_{\text{max}} = 0.63$  nmol  $\times$  min $^{-1}$  per mg protein). The low activity could not be attributed to a low quality of the membrane preparation but appears to indicate a low density of  $\text{Ca}^{2+}$ -ATPase therein. Surprisingly, a very high  $\text{Na}^+/\text{K}^+$ -ATPase could be demonstrated in these

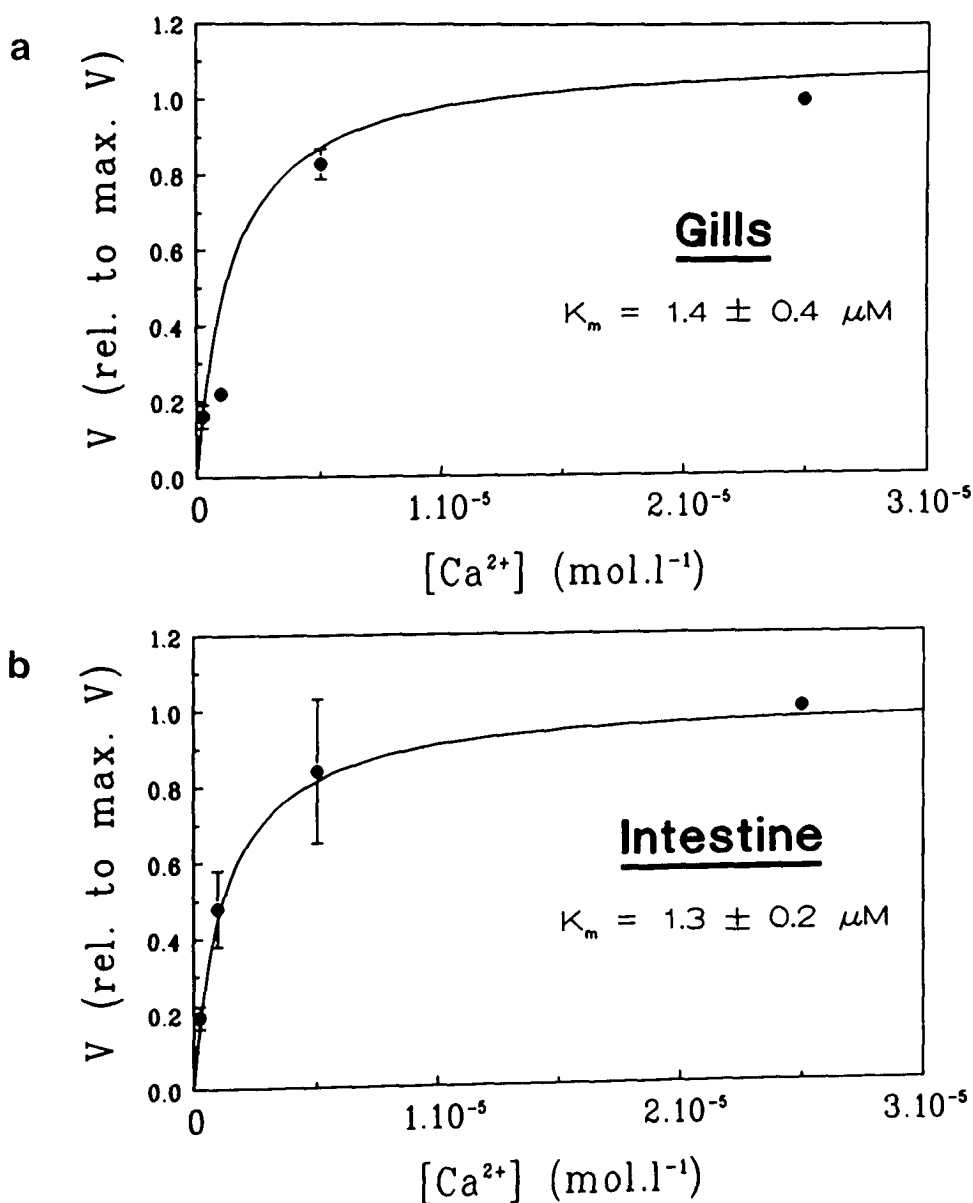

Fig. 5.  $\text{Na}^+/\text{Ca}^{2+}$  exchange in gills and intestine.  $\text{Ca}^{2+}$  dependence of  $\text{Na}^+$ -driven  $\text{Ca}^{2+}$  uptake into vesicles of gill epithelium (a) and intestinal epithelium (b). Initial rates of  $\text{Na}^+$ -driven  $\text{Ca}^{2+}$  uptake ( $\text{Na}^+/\text{K}^+$ ) were corrected for "nonspecific" uptake ( $\text{Na}^+_i = \text{Na}^+_o = 150 \text{ mM}$ ).  $\text{Ca}^{2+}_o$  was varied between  $10^{-6}$  and  $2.5 \cdot 10^{-5} \text{ M}$ . Uptake rates have

been plotted relative to the maximum velocities observed for comparison ( $V_{\text{max}} = 12.2 \pm 3.7$  and  $20.5 \pm 4.4 \text{ nmol} \times \text{min}^{-1}$  per  $\text{mg protein}^{-1}$  for gills and intestine, respectively). The  $K_m$ -values are given in the figures. Mean values for six fish are given. Bars indicate SE.

membranes (specific activity around  $150 \mu\text{mol P}_i \times \text{h}^{-1}$  per  $\text{mg protein}$  versus  $30 \mu\text{mol P}_i \times \text{h}^{-1}$  per  $\text{mg protein}$  in a comparable plasma membrane preparation of gill cells). The high  $\text{Na}^+/\text{K}^+$ -ATPase activity also argues against a low quality preparation. However, a powerful  $\text{Na}^+/\text{Ca}^{2+}$  exchange activity ( $K_{0.5} = 181 \text{ nM}$ ;  $V_{\text{max}} = 7.2 \text{ nmol} \times \text{min}^{-1}$  per  $\text{mg protein}$ ) was present in the plasma membranes of the enterocytes (Flik et al., '90b). The maximum activity of the exchanger exceeds that of

the  $\text{Ca}^{2+}$ -ATPase in the same membrane more than tenfold and that of any known  $\text{Na}^+/\text{Ca}^{2+}$  exchange activity in (mammalian) non-excitable cells. An observation not understood at that time was the curvilinear calcium dependence of the exchanger (Flik et al., '90b), but very recently we have been able to solve this problem by improving on the procedures for calculation of free  $\text{Ca}^{2+}$  concentrations in physiological solutions (Schoenmakers et al., '92a,b). The improved calculation method



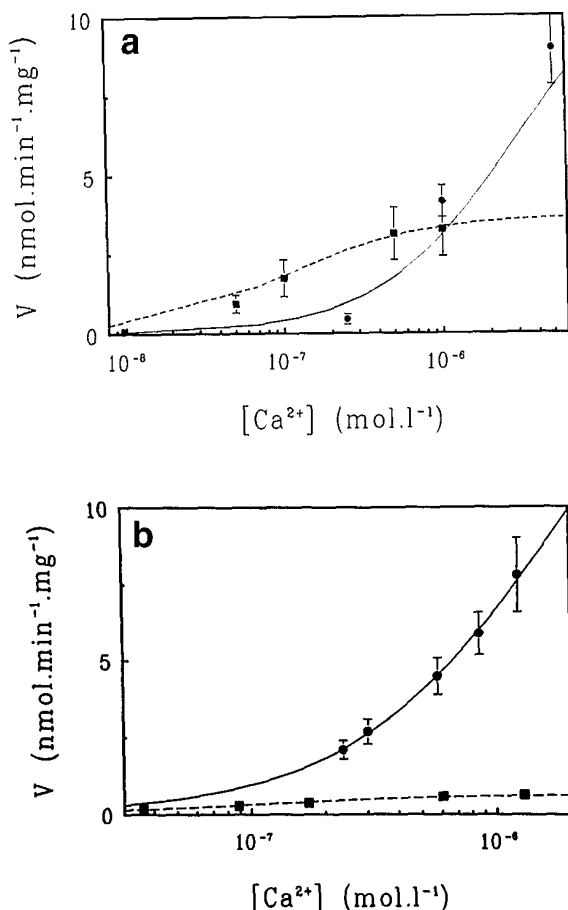

Fig. 6. The activity of the Ca<sup>2+</sup>-ATPase (dotted lines) and Na<sup>+</sup>/Ca<sup>2+</sup> exchanger (solid lines) in the basolateral plasma membrane of the gills (a) and the intestine (b) as a function of the calcium concentration in the cell. In the intestine the exchanger determines for the major part the extrusion of Ca<sup>2+</sup>. In the gills the Ca<sup>2+</sup>-ATPase is dominant in the export of Ca<sup>2+</sup> from the cell. The transport activities of both extrusion mechanisms were determined on the same resealed vesicle preparations of the respective plasma membranes. Note that at the calcium concentrations given on the x-axis, the exchanger does not reach saturation. Mean values for six fish are given; bars indicate SE; in some cases the SE bars fall within the symbol used. Data were fitted by non-linear regression analysis.

yields single Michaelis-Menten kinetics for the exchanger and leads in particular to higher estimates for the  $V_{\max}$  of the exchanger.

In Figure 6b, the activities of the Ca<sup>2+</sup>-ATPase ( $K_{0.5}$ :  $106 \pm 21$  nM,  $V_{\max}$ :  $0.66 \pm 0.15$  nmol  $\times$  min<sup>-1</sup>  $\times$  mg protein<sup>-1</sup>) and the Na<sup>+</sup>/Ca<sup>2+</sup> exchanger ( $K_{0.5}$ :  $1.95 \pm 0.45$   $\mu$ M,  $V_{\max}$ :  $19.6 \pm 3.6$  nmol  $\times$  min<sup>-1</sup>  $\times$  mg protein<sup>-1</sup>; roughly 30 times higher than the ATPase!), determined anew proceeding from the most updated calculations for free Ca<sup>2+</sup>, are plotted as a function of cytosolic Ca<sup>2+</sup>. The exchanger dominates the calcium extrusion in the enterocyte.

This contention is in good agreement with the Na<sup>+</sup> dependence of calcium absorption in the intestine of this fish (Flik et al., '90b). In the model presented in Figure 1, the dominant Ca<sup>2+</sup> transport pathway in the enterocyte is indicated as route 2.

Among the intriguing questions arising is how the exchanger is regulated. The Na<sup>+</sup> dependence of a Ca<sup>2+</sup> extrusion mechanism couples calcium homeostasis directly to sodium homeostasis, at least for this tissue. The endocrinological and physiological implications of this notion are of course manifold.

## MAGNESIUM TRANSPORT

Magnesium is an essential element for all vertebrates, indispensable for proper functioning of all cells and involved in a variety of enzymic reactions. How magnesium is transported and how the transport is regulated is, essentially, an open question. We have studied Mg<sup>2+</sup> transport phenomena in tilapia and carp. So far, special attention was paid to gills and intestine. The major impetus for the studies described below comes from the recent availability of reactor-produced Mg<sup>2+</sup> radioisotopes, <sup>27</sup>Mg<sup>2+</sup> and <sup>28</sup>Mg<sup>2+</sup> (Van der Velden et al., '90; Kolar et al., '91).

### Gills

The magnesium concentration in fresh water ranges mostly between 0.1 and 0.3 mM. For freshwater fish the ambient water thus represents an inexhaustible magnesium source (a similar reasoning holds true for calcium). Yet freshwater fish normally do not rely on absorption of Mg<sup>2+</sup> from the water via their gills. When fed a low Mg diet, some fish (guppy, carp) may die even though Mg is present in the water (Shim and Ng, '88; Ogino and Chiou, '76); other species (rainbow trout, tilapia) survive such diets and even continue to grow (Knox et al., '83; Van der Velden et al., '91a). For the tilapia fed a low magnesium diet, we have calculated that the fish must absorb Mg<sup>2+</sup> via its gills from the water to explain the growth observed (Van der Velden et al., '91b). However, we were unable to show any change in Mg<sup>2+</sup> uptake from the water between control fish and low Mg fed tilapia (Van der Velden et al., '91a). For the carp, kept in water containing 0.2 mM Mg and fed a diet containing  $31 \mu\text{mol} \times \text{g}^{-1}$  at maintenance level, the relative contribution of branchial magnesium uptake to the total magnesium uptake was calculated to be, at maximum, 16% (Van der Velden, '91). At least 84% is obtained from the food. For tilapia weighing 6.5 g, feeding on a control diet ( $25 \mu\text{mol} \times \text{g}^{-1}$ ), and kept in water containing 0.2 mM Mg, the con-

tribution of branchial  $Mg^{2+}$  uptake from the water was calculated to  $13 \text{ nmol} \times \text{h}^{-1}$ , the contribution of drinking Mg containing water to  $16 \text{ nmol} \times \text{h}^{-1}$  maximally, and the contribution of Mg absorption from the food to  $329 \text{ nmol} \times \text{h}^{-1}$  maximally. For a fish feeding on a low Mg diet ( $1 \mu\text{mol} \times \text{g}^{-1}$ ) these numbers are 12, 6, and  $14 \text{ nmol} \times \text{h}^{-1}$ , respectively (Van der Velden et al., '91a; Van der Velden, '91). Clearly the tilapia does not increase extraintestinal  $Mg^{2+}$  uptake when fed a low Mg diet. In the latter situation, however, extraintestinal  $Mg^{2+}$  uptake stands for 50% of the total uptake!

For magnesium uptake in fish, the situation is opposite to that for calcium uptake: a not fully understood, small part of the uptake occurs normally via the gills, and the major route for  $Mg^{2+}$  uptake is via the intestine.

### Intestine

There is ample evidence for absorption of  $Mg^{2+}$  by fish intestine. Many studies have given clear but indirect evidence by providing the fish with diets varying in Mg content and subsequently analyzing tissue elemental composition, growth rate, etc. A photonuclear reaction process has made available a preparation of  $^{28}\text{Mg}^{2+}$  with very high specific activity and it allowed us to perform some studies on unidirectional  $Mg^{2+}$  fluxes in tilapia intestine (Van der Velden et al., '90). Net absorption of  $Mg^{2+}$  could be demonstrated and a sodium dependence established (Table 1). In control conditions with saline bathing the mucosal and the serosal sides of tilapia stripped epithelium, the net mucosa to serosa flux was  $23 \text{ nmol} \times \text{h}^{-1} \times \text{cm}^{-2}$ . When sodium was replaced by the inert ion NMDG<sup>+</sup> (sodium free condition), unidirectional fluxes were strongly reduced and the net flux was abolished. Ouabain, known to completely block  $\text{Na}^+/\text{K}^+$ -ATPase activity in this tissue (Flik et al., '90b), reduces the mucosa to serosa flux to the level found for the serosa to mucosa flux. Apparently this blocker inhibits the transcellular movement of  $Mg^{2+}$ .

TABLE 1. Magnesium fluxes (J)  $\pm$  standard deviation across stripped intestinal epithelium of freshwater tilapia under different experimental conditions<sup>1</sup>

Saline conditions	Unidirectional $Mg^{2+}$ fluxes in tilapia intestine	
	$J_{ms}$	$J_{sm}$
Control	$39 \pm 19$ (9)	$16 \pm 6$ (8)
Sodium-free	$6 \pm 3$ (7)	$6 \pm 2$ (10)
+ Ouabain (1 mM)	$16 \pm 2$ (3)	N.D.

<sup>1</sup>The number of observations are indicated between brackets. Data taken from Van der Velden et al. ('90).

On the basis of analyses of the elemental composition of the epithelium and electrophysiological data (inside of the cell  $-60 \text{ mV}$ ) (Bakker and Groot, '88), we have concluded that intracellular  $Mg^{2+}$  ( $8 \text{ mmol} \times 1^{-1}$ ) is kept far below its equilibrium concentration ( $100 \text{ mmol} \times 1^{-1}$ ; bath ringers Mg was  $1 \text{ mmol} \times 1^{-1}$ ). It follows then that transport over the apical membrane may be passive and driven by an electrochemical potential difference of at least 25 mV. This value is probably too low, because the major part of the  $Mg^{2+}$  in the cell is in a bound form. Conversely, transcellular  $Mg^{2+}$  transport requires an energized extrusion step at the basolateral side of the cell to counteract the potential difference of at least 30 mV. Either ATP or the  $\text{Na}^+$  gradient over this membrane could provide the energy for such transport. In our Ussing chamber setup, the magnesium concentrations in both hemichambers were always identical. Also there is no electrical gradient across the epithelium in this setting. It follows then that the transport of  $Mg^{2+}$  must result from net water transport (solvent drag  $Mg^{2+}$  transport), from an active transport mechanism, or a contribution of both. The sodium dependence of the  $Mg^{2+}$  transport suggests, of course, the operation of an  $\text{Na}^+/\text{Mg}^{2+}$  exchanger. The latter hypothesis was tested in studies with tilapia enterocyte basolateral plasma membrane vesicles in which  $Mg^{2+}$  transport was determined with  $^{27}\text{Mg}^{2+}$  as radiotracer (Kolar et al., '91). So far, we have been unable to determine  $\text{Na}^+/\text{Mg}^{2+}$  exchange in assays which were comparable in their setup to those for the determination of  $\text{Na}^+/\text{Ca}^{2+}$  exchange (Flik et al., '90b). However, a consistent finding so far is that ATP stimulates  $Mg^{2+}$  transport into these vesicles (Kolar et al., '91). A characterization of ATP-driven  $Mg^{2+}$  transport in plasma membrane vesicles has been carried out (Flik et al., submitted) and this finding will open a new field of research.

How magnesium transport in fish is regulated is still an enigma. STC appears not to be involved (Hirano, '89). External magnesium levels influence prolactin cell activity (Wendelaar Bonga et al., '85). Some further circumstantial evidence for a role of prolactin in magnesium homeostasis comes from diet experiments with tilapia: long-term low Mg diets result in chronically activated prolactin cells (Van der Velden et al., '91b). How prolactin affects magnesium transport is as yet unknown.

### ACKNOWLEDGMENTS

The authors gratefully acknowledge Mrs. T. G. Verburg and Mr. W. Atsma for skillful assis-

tance during experiments. Mr. F.A.T. Spanings is thanked for the excellent organization of the tilapia husbandry.

### LITERATURE CITED

- Bakker, R., and J.A. Groot (1988) Induction of bumetanide-sensitive Na(K)Cl transport and K<sup>+</sup> permeability in the apical membrane of intestinal epithelium of *Oreochromis mossambicus* due to seawater adaptation. *Comp. Biochem. Physiol.*, 90A:824.
- Fenwick, J.C., K. Smith, J. Smith, and G. Flik (1984) Effects of various vitamin D analogs on plasma calcium and phosphorus and intestinal calcium absorption in fed and unfed American eels, *Anguilla rostrata*. *Gen. Comp. Endocrinol.*, 55:398-404.
- Flik, G., S.E. Wendelaar Bonga, and J.C. Fenwick (1984a) Ca<sup>2+</sup>-dependent phosphatase and Ca<sup>2+</sup>-dependent ATPase activities in plasma membrane of eel gill epithelium—II. Evidence for transport high-affinity Ca<sup>2+</sup>-ATPase. *Comp. Biochem. Physiol.*, 79B:9-16.
- Flik, G., S.E. Wendelaar Bonga, and J.C. Fenwick (1984b) Ca<sup>2+</sup>-dependent phosphatase and Ca<sup>2+</sup>-dependent ATPase activities in plasma membranes of eel gill epithelium—III. Stimulation of branchial high-affinity Ca<sup>2+</sup>-ATPase activity during prolactin-induced hypercalcemia in American eels. *Comp. Biochem. Physiol.*, 79B:521-524.
- Flik, G., J.H. van Rijs, and S.E. Wendelaar Bonga (1985a) Evidence for high-affinity Ca<sup>2+</sup>-ATPase and ATP-driven Ca<sup>2+</sup>-transport in membrane preparations of the gill epithelium of the cichlid fish *Oreochromis mossambicus*. *J. Exp. Biol.*, 119:335-347.
- Flik, G., S.E. Wendelaar Bonga, and J.C. Fenwick (1985b) Active Ca<sup>2+</sup>-transport in plasma membranes of branchial epithelium of the North-American eel *Anguilla rostrata* LeSueur. *Biol. Cell*, 55:265-272.
- Flik, G., J.C. Fenwick, Z.I. Kolar, N. Mayer-Gostan, and S.E. Wendelaar Bonga (1986a) Whole-body calcium flux rates in cichlid teleost fish *Oreochromis mossambicus* adapted to fresh water. *Am. J. Physiol.*, 249:R432-R437.
- Flik, G., J.C. Fenwick, Z.I. Kolar, N. Mayer-Gostan, and S.E. Wendelaar Bonga (1986b) Effects of low ambient calcium levels on whole-body Ca<sup>2+</sup>-flux rates and internal calcium pools in the freshwater cichlid teleost, *Oreochromis mossambicus*. *J. Exp. Biol.*, 120:249-266.
- Flik, G., J.C. Fenwick, Z.I. Kolar, N. Mayer-Gostan, and S.E. Wendelaar Bonga (1986c) Effects of ovine prolactin on calcium uptake and distribution in *Oreochromis mossambicus*. *Am. J. Physiol.*, 250(2):R161-R166.
- Flik, G., and S.F. Perry (1989) Cortisol stimulates whole body calcium uptake and the branchial calcium pump in freshwater rainbow trout. *J. Endocrinol.*, 120:75-82.
- Flik, G., J.C. Fenwick, and S.E. Wendelaar Bonga (1989a) Calcitropic actions of prolactin in freshwater North American eel (*Anguilla rostrata* LeSueur). *Am. J. Physiol.*, 257:R74-R79.
- Flik, G., T. Labeledz, F.P.J.G. Labeber, S.E. Wendelaar Bonga, and P.K.T. Pang (1989b) Studies on teleost corpuscles of Stannius: Physiological and biochemical aspects of synthesis and release of hypocalcin in trout, goldfish and eel. *Fish Physiol. Biochem.*, 7:343-349.
- Flik, G., T. Labeledz, J.A.M. Neelissen, R.G.J.M. Hanssen, S.E. Wendelaar Bonga, and P.K.T. Pang (1990a) Rainbow trout corpuscles of Stannius: Stanniocalcin synthesis in vitro. *Am. J. Physiol.*, 258:R1157-R1164.
- Flik, G., T.J.M. Schoenmakers, J.A. Groot, C.H. van Os, and S.E. Wendelaar Bonga (1990b) Calcium absorption by fish intestine: The involvement of ATP- and sodium-dependent calcium extrusion mechanisms. *J. Membr. Biol.*, 113:13-22.
- Flik, G. (1990) Hypocalcin Physiology. In: *Progress in Comparative Endocrinology*. A. Eppele, C.G. Scanes, and M.H. Stetson, eds. Wiley-Liss, Inc., New York, pp. 578-585.
- Flik, G., J.A. van der Velden, T.G. Verburg, A.M.J.A. Linders, Z.I. Kolar, and S.E. Wendelaar Bonga (submitted) ATP-driven transport in basolateral plasma membrane vesicles of enterocytes of the tilapia, *Oreochromis mossambicus*. *Eur. J. Biochem.*
- Hanssen, R.G.J.M., F.P.J.G. Labeber, G. Flik, and S.E. Wendelaar Bonga (1989) Ionic and total calcium levels in the blood of the european eel (*Anguilla anguilla*): Effects of stanniectomy and hypocalcin replacement therapy. *J. Exp. Biol.*, 141:177-186.
- Hirano, T. (1989) The corpuscles of Stannius. In: *Vertebrate Endocrinology: Fundamentals and Biomedical Implications*, Vol. 3. P.K.T. Pang and M.P. Schreibmann, eds. Academic Press, New York, pp. 139-170.
- Knox, D., C.B. Cowey, and J.W. Adron (1983) Studies on the nutrition of rainbow trout (*Salmo gairdneri*). Magnesium deficiency: The effects of feeding with a Mg-supplemented diet. *Br. J. Nutr.*, 50:121-127.
- Kolar, Z.I., J.A. van der Velden, G. Flik, and J.J.M. de Goelj (1991) <sup>27</sup>Mg<sup>2+</sup> and <sup>28</sup>Mg<sup>2+</sup> preparation and use as radio-tracers in magnesium physiology oriented studies of tilapia. In: *Magnesium—A Relevant Ion?* B. Lasserre and J. Durlach, eds. John Libbey, London, pp. 299-306.
- Labeber, F.P.J.G., G. Flik, S.E. Wendelaar Bonga, and S.F. Perry (1988) Hypocalcin from Stannius corpuscles inhibits gill calcium uptake in trout. *Am. J. Physiol.*, 254:R891-R896.
- Ma, M.Y., and D.H. Copp (1978) Purification, properties and action of a glycopeptide from the corpuscles of Stannius which affect calcium metabolism in the teleost. In: *Comparative Endocrinology*. P.J. Gaillard and H.H. Boer, eds. Elsevier Biomedical Press, Amsterdam, pp. 283-286.
- Ogino, C., and J.Y. Chiou (1976) Mineral requirements in fish. II. Magnesium requirements of carp. *Bull. Japan. Soc. Sci. Fish.*, 42:71-75.
- Perry, S.F., and G. Flik (1988) Characterization of branchial transepithelial calcium fluxes in freshwater trout, *Salmo gairdneri*. *Am. J. Physiol.*, 254:R491-R498.
- Schoenmakers, T.J.M., P.H.M. Klaren, G. Flik, R.A.C. Lock, P.K.T. Pang, and S.E. Bonga Wendelaar (1992a) Actions of cadmium on basolateral plasma membrane proteins involved in calcium uptake by fish intestine. *J. Membr. Biol.*, in press.
- Schoenmakers, T.J.M., G.J. Visser, G. Flik, and A.P.R. Theuvenet (1992b) Chelator: An improved method for computing metal ion concentrations in physiological solutions. *Biotechniques*, 12:870-879.
- Shim, K.F., and S.H. Ng (1988) Magnesium requirement of the guppy (*Poecilia reticulata* Peters). *Aquaculture*, 73:131-141.
- Takagi, Y., Y. Nakamura, and J. Yamada (1985) Effects of the removal of corpuscles of Stannius on the transport of calcium across the intestine of rainbow trout. *Zool. Science*, 2:523-530.
- Van der Velden, J.A. (1991) Magnesium and its transport in tilapia and carp: A study based on nuclear methods. Ph. D. Thesis, Technical University, Delft.
- Van der Velden, J.A., J.A. Groot, G. Flik, P. Polak, and Z.I. Kolar (1990) Magnesium transport in fish intestine. *J. Exp. Biol.*, 152:587-592.

- Van der Velden, J.A., Z.I. Kolar, and G. Flik (1991a) Intake of magnesium from the water by freshwater tilapia fed on a low-Mg diet. *Comp. Biochem. Physiol.*, 99A:103-105.
- Van der Velden, J.A., F.A.T. Spanings, G. Flik, C. Zegers, Z.I. Kolar, and S.E. Wendelaar Bonga (1991b) Growth rate and tissue magnesium concentration in adult freshwater tilapia, *Oreochromis mossambicus* (Peters), fed diets differing in magnesium content. *J. Fish Biol.*, 39:83-91.
- Verboost, P.M., J. van Rooij, G. Flik, R.A.C. Lock, and S.E. Wendelaar Bonga (1989) The movement of cadmium through freshwater trout branchial epithelium and its interference with calcium transport. *J. Exp. Biol.*, 145:185-197.
- Wendelaar Bonga, S.E., G. Flik, C.W.G.M. Löwik, and G.J.J. M. van Eijs (1985) Environmental control of prolactin synthesis in the teleost fish *Oreochromis* (formerly *Sarotherodon*) *mossambicus*. *Gen. Comp. Endocrinol.*, 57:352-359.
- Wendelaar Bonga, S.E., G. Flik, P.H.M. Balm, and J.C.A. van der Meij (1990) The ultrastructure of chloride cells in the gills of the teleost *Oreochromis mossambicus* during exposure to acidified water. *Cell Tissue Res.*, 259:575-585.