

CAD-CAE METHODOLOGY APPLIED TO ANALYSIS OF A GEAR PUMP

Ionuț GHIONEAN^{1,*}, Adrian GHIONEAN², George CONSTANTIN³

¹⁾ PhD, Lecturer, Machine Building Technology Department, University "Politehnica" of Bucharest, Romania

^{2,3)} PhD, Prof., Machines and Manufacturing Systems Department, University "Politehnica" of Bucharest, Romania

Abstract: *The use of modern CAD and FEM techniques in the conception, simulation and manufacturing processes of industrial products has a large application in the mechanical, automotive and aerospace industry domains. This paper presents important aspects of a practical methodology applied to design a gear pump using the CATIA software parametric abilities followed by a FEM analysis of its assembly to identify the most stressed components. In the parametric design of the gear pump some of its constructive and functional data, among them, the flow being the main parameter, were taken into account.*

Key words: *parametric modelling, gear pump, constructive variants, FEM analysis.*

1. INTRODUCTION

To design an industrial product in a parametric manner, there are some steps to be achieved using CAD/CAM/FEM software solutions [1 and 3].

In this paper, to create and simulate a gear pump manufactured by a Romanian company in a large number of constructive variants, it was identified the need to model its assembly in an advanced CAD program, with parametric abilities. The purpose of this modelling is that the pump should cover a domain of flows demanded by the company [4 and 5] customers.

The costs and resources necessary for testing the real product in the phase of design are big comparative to a simulation of the virtual model. It would be necessary a physical prototype and also a set up for testing, tools necessary for acquisition, storage and processing data from experimental measurements.

Thus, the following steps were analyzed: identifying the pump functional role and its components, dimensions and assembly conditions, choosing the CAD/FEM system for modelling and simulation, parametric 3D modelling of the pump assembly, establishing the dimensional and functional relations between the components' dimensions and the FEM analysis of the pump gear in some imposed conditions.

2. GEAR PUMP ASSEMBLY: FUNCTIONAL ROLE AND COMPONENTS

The gear pumps have a large use in many industrial and general use products due to a constructive simplicity, a low production cost and a real smooth and reliable operation.

These pumps, having an external involute gear, are the most usual types, used in many installations at different pressure levels. In principle, this kind of pump is composed of impeller rotors mounted on transmission shafts or being one part with them, a pump body, a compensator, a casing cover, different sealing elements, fittings, screws and set pins.

The gear volumes (cups) represent the gashes between two consecutive teeth that pass one after another through the aspiration chamber. These gashes are filled with fluid which is then transported and delivered under pressure in the discharge chamber [3].

Usually, the pumps' flows vary between 2 and 1 000 l/min, driving power up to 30–40 kW and speed between 700 and 7 000 rpm. The flow variation may be obtained from different constructive variants using the same rotating speed or by changing it while keeping a certain variant [2].

The resultant of the pressure forces on gears loads and stresses the body and casing cover bearings and, also, the gears themselves. These loads and stresses may drive to a long-service wear, vibrations, fluid leaks and performance diminution.

To partially counter the problems, the gear pump components are manufactured of specific materials that confer good mechanical strength characteristics, low wear, imposed reliability, precision of assembly, good machinability: aluminium alloys (body, casing cover, compensator) and steel alloys (gears and shafts).

3. STAGES OF PARAMETRIC DESIGN OF THE GEAR PUMP

For the computer aided design phase it was used the CATIA program due to its high abilities of solid parametric modelling, assembling and simulation. Using the dimension values and assembly constraints kindly disposed by the pumps company for this applicative study [8], it was created a 3D model for each component and the pump assembly.

* Corresponding author: Splaiul Independenței 313, Sector 6, 060042, Bucharest, Romania,
Tel.: 040 21 402 9174;
E-mail addresses: adrianghionea@yahoo.com (A. Ghionea),
ionut76@hotmail.com (G.I. Ghionea),
george.constantin@icmas.eu (G. Constantin).

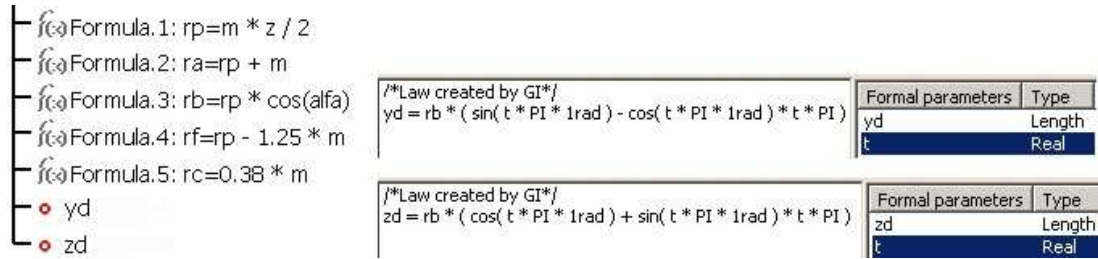

Fig. 1. Parametric coordinates of points and formulas to define the tooth profile.

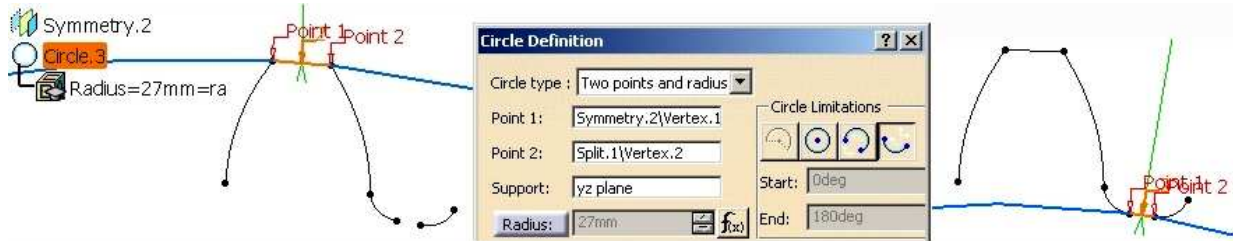

Fig. 2. Completing the tooth profile.

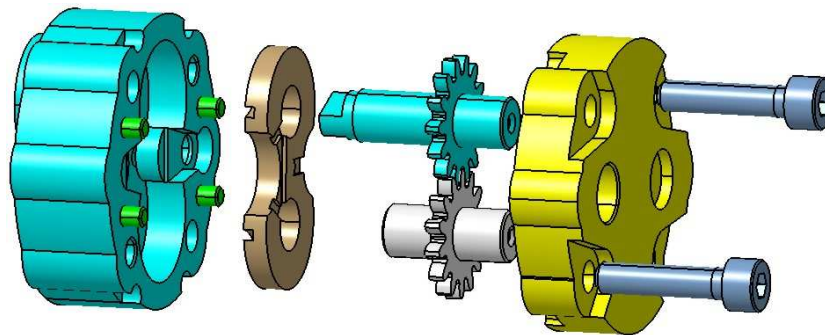

Fig. 3. The gear pump assembly in a 3D exploded view.

3.1. Modelling the spur gearing

The first and one of the most important phases of the parametric modelling was to obtain a correct involute gear according to the imposed flow conditions and to the distance between the two shafts axes. The parametric equations [2] of the teeth profiles are:

$$\begin{cases} yd = rb \cdot (\sin(t \cdot \pi) - \cos(t \cdot \pi) \cdot t \cdot \pi) \\ zd = rb \cdot (\cos(t \cdot \pi) + \sin(t \cdot \pi) \cdot t \cdot \pi) \end{cases}, \quad (1)$$

where: rb – base circle radius and t – rolling parameter. Also, there are some other parameters used to draw the involute curve: alfa – pressure angle of reference, deg; m – gear normal module, mm; z – number of teeth, p – gear pitch on the reference line, mm; ra – radius of the head-circle, mm; rf – radius of the root circle, mm; rc – fillet radius at the tooth root, mm.

The parameters are of different types: angle, length and integer and are used not only to draw a profile, but also later in the solid modelling process to change the characteristics of the pump gear.

All these parameters and the Eq. (1) are used to write some formulas and to express the coordinates yd and zd (as laws, Fig. 1) that define a tooth profile.

A number of five points are used to draw the profile, connected by a spline curve [2]. This curve is extrapolated to touch the root circle and then rotated with an angle ϕ , Eq. (2) dependant on the parametric laws yd and zd .

$$\phi = \text{atan}(yd(c) / zd(c)) + 90 \text{ deg}/z, \quad (2)$$

where: c – a parameter used to indicate the position of an involute point on the pitch circle:

$$c = \text{sqr}(1 / \cos(\text{alfa})^2 - 1) / \text{PI} \times 180 \text{ deg}, \quad (3)$$

Using the CATIA Part Design module, all the pump components were modelled and then assembled in the CATIA Assembly Design module applying various geometrical and dimensional constraints.

3.2. 3D model of the pump

The next step is the assembly parameterization. The main parameter used in this purpose is the flow transmitted by the pump, which is directly connected to one of the fundamental pumps characteristic, called geometric volume V_g , expressed through the equation given in [4, 7]. Figure 3 presents the gear pump in a 3D visualization.

Table 1

Values of parameters that determine the pump flow

No.	Pump flow Q_p , l/min	Speed n , rpm	Efficiency η_v , %	Geometric volume V_g , cm ³	Gash profile area A_{gob} , cm ²	Gear width b , mm	Body width H , mm	Compensator width l , mm
1	2.11	3 000	88	0.8	0.147	2.3	25	7.7
2	2.64			1		2.8		7.2
3	3.17			1.2		3.4		6.6
4	4.48			1.7		4.8		25.5
5	5.94		90	2.2		6.2	30	8.8
6	7			2.6		7.4	32	7.6
7	8.64			3.2		9	30	6
8	10.6			3.8		10	35	10
9	12		93	4.3		12		8
10	13.11			4.7		13.3		6.7
11	16.92		94	6		17		40
12	22			7.8		22.1	45	7.9

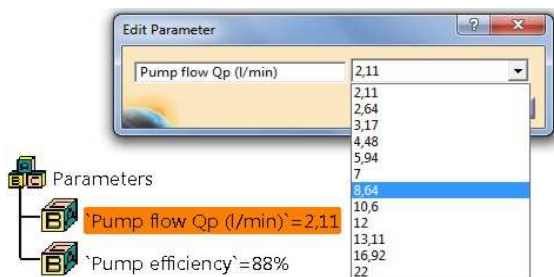

Fig. 4. Selection of the pump flow value.

$$V_g = 2 \cdot z \cdot b \cdot A \cdot 10^{-3} \text{ [cm}^3/\text{rot]}. \quad (4)$$

where: z – number of teeth, b – gear width, mm, A – area of the gash profile between two consecutive teeth, in mm², (Fig. 2). The gash profile area decreases with an increase of the teeth number which determines an increase of the interior pump gauge.

Further, the pump flow Q_p is calculated with the Eq. (5), where: n – rotational speed of the driving shaft, rpm, and η_v – volumetric efficiency. In the considered case, $n = 3\,000$ rpm and $\eta_v = 93\%$, but these values may be different due to the pumps large diversity:

$$Q_p = \frac{V_g \cdot n}{10^3} \cdot \eta_v \text{ [l/min]}. \quad (5)$$

In this diversity, the gears width is established according to a specific value of the geometrical volume V_g that is specific to a HP05 series of pumps [4, 5, and 7]. In the company specifications catalogue, the standard value of this parameter is 1.2 cm³/rot.

The applicative methodology used in the current paper has the aim to increase the geometrical volume without the change of the overall dimensions and of the external shape for the pump body and casing cover stocks. Thus, it is possible to increase the pump flow and it would not be necessary to choose another pump that is different and cannot be mounted in a certain industrial installation.

Using the initial dimensions of the pump components and imposing a nominal rotational speed, some assembly and dimensional constraints there are parametrically

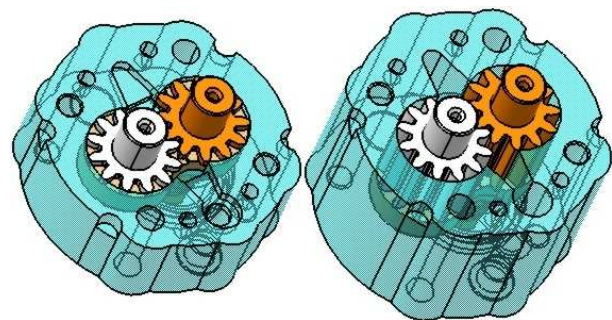

Fig. 5. The pump assembly for min/max flow values.

determined some dimensions for components (gears, compensator and body widths, depths of the body bored holes, etc.). The parameterized 3D models of the pump body, gears and compensator are automated redesigned on the basis of some relations, a function activated by user and the flow values given by the pump. Also, there are considered certain values of the volumetric efficiency established by the authors during a study applied to a series of similar pumps manufactured by different companies. The parameters values and their correlation are presented in Table 1.

Thus, the parameterized models of the pump components are automatically modified using relations and a reaction [2] written in *Visual Basic* in CATIA environment. As a result, a potential user dispose of a friendly interface, he may choose the pump flow value from a drop down list (Fig. 4) and the entire pump assembly is updated accordingly.

The relations and the reaction code are organized on sections, conditionally dependent on the chosen flow value. When a certain value is selected from the list, its code section calculates the subsequent parameters and updates the pump. As follows, there is presented a small fragment of the reaction code, when is determined the min/max flow values.

Figure 5 presents the assembly parameterized model [2] (without the pump cover and bolts) in the cases of the flow equal to 2.11 l/min and 22 l/min.

```
if `Pump flow Qp (l/min)` ==2.11
{`gear\gear\Pad.1\FirstLimit\Length`=2.3mm
body\PartBody\Pad.1\FirstLimit\Length =25mm
body\PartBody\Pocket.6\FirstLimit\Depth =10mm
```

```

compensator\PartBody\Pad.1\FirstLimit\Length = 7.7mm
`gear1\gear\Pad.3\FirstLimit\Length` = 23mm + 1.7mm
`gear2\gear\Pad.3\FirstLimit\Length` = 15mm + 1.7mm
body\PartBody\Pad.3\FirstLimit\Length = 2mm
body\PartBody\Pad.8\FirstLimit\Length = 2mm
`Pump efficiency` = 0.88}
else if `Pump flow Qp (l/min)` == 22
{`gear1\gear\Pad.1\FirstLimit\Length` = 22.1mm
body\PartBody\Pad.1\FirstLimit\Length = 45mm
body\PartBody\Pocket.6\FirstLimit\Depth = 30mm
compensator\PartBody\Pad.1\FirstLimit\Length = 7.9mm
`gear1\gear\Pad.3\FirstLimit\Length` = 23mm - 18mm + 20mm
`gear2\gear\Pad.3\FirstLimit\Length` = 15mm - 18mm + 20mm
body\PartBody\Pad.3\FirstLimit\Length = 2mm
body\PartBody\Pad.8\FirstLimit\Length = 2mm
`Pump efficiency` = 0.94}

```

4. FEM ANALYSIS OF THE GEAR PUMP

In terms of construction, the main issues specific to operation of external cylindrical gear pumps are: ensuring the bearings capacity and maintaining the volume efficiency at high level throughout the operation. They get worse especially for pumps operating at pressures greater than 120 bar.

Basically, the design of the outer cylindrical gear pumps also requires, prior determination of the forces acting on gears, shafts and their bearings.

Bearings are loaded by radial components of the elemental pressure forces on gears and also by meshing forces corresponding to the components of the pressure forces on the flanks of teeth in each gap between two teeth (Fig. 6).

In the zone of arc of each tooth head there is also a distribution of pressure, its variation between a gash and the headcircle area is considered to be very small, so that the radial pressure distribution is also considered continuous. The meshing forces along the gearing line decompose on tangential and radial directions.

Thus, the calculation of resultants of these forces requires knowledge of the pressure distribution created at the wheel z_1 and z_2 periphery (Fig. 6), which depends on the pressure distribution and preservation of fit achieved between each wheel and the pump body bore, and also on the location of the sealing area of the pump.

It was ascertained that in the operation under nominal pressure nominal, its distribution has a parabolic shape. The radial clearance (sliding fit) between gears and their bores in the pump body influences the flow and discharge pressure of liquid. Other factors are: type, dimensions, dynamic behaviour of the gear bearings.

Exerting pressure created on the peripheral surfaces of the gears creates a resistant torque which is surpassed by the driving gear engagement. The necessary torque determines the electric motor power given by relation (6)

$$P = \frac{Q_p \cdot p}{6 \cdot \eta_t} = \frac{10^{-3} \cdot V_g \cdot n \cdot p}{6 \cdot \eta_m} \text{ [kW]}, \quad (6)$$

where Q_p is the pump flow (l/min), V_g – geometric volume of the pump (cm^3/rot), n – speed of the driving shaft (rot/min), η_t – total efficiency (%). In the considered case, according to the producer specifications, $\eta_t = 84\%$.

The applied force on the teeth (also on the liquid) on direction $x-x$, due to the applied torque to the driving gear (pinion z_1) can be calculated by relation (7):

$$F_d = \frac{2 \cdot M_a}{D_w}, \text{ [N]} \quad (7)$$

where M_a is the torque necessary at the driving shaft (N·mm); D_w – rolling diameter of the gears (mm). The torque M_a results with some approximations from relation (8):

$$M_a = p \cdot m^2 \cdot b \cdot (z_1 + 1) \text{ [N·mm]}, \quad (8)$$

where p is the pressure created in pump (chamber D) during functioning (bar), $b = \lambda \cdot m$ – width of the teeth (mm), λ – width coefficient, m – tooth modulus (mm) and z_1 – number of teeth of the driving gear. The rolling diameter for the corrected teeth is expressed by the relation (9):

$$D_{w12} = m \cdot (z_{12} + 2 \cdot \xi_{12}) \text{ [mm]}, \quad (9)$$

where ξ represents the specific addendum modification.

Thus, the expression of the force applied on the teeth becomes:

$$F_d = 2 \cdot p \cdot m \cdot b \text{ [N]}, \quad (10)$$

and represents the tangential component of the force acting on one tooth of the driving gear z_1 according to Fig. 6.

The liquid under pressure in the gap between teeth creates a load on radial direction on both gears. The pressure varies from a minimum value (atmospheric pressure in aspiration chamber A) to a maximum one – pressure in discharge chamber D considered to be as rated pressure of the pump (Fig. 6). For an angular variation $\varphi \in (0 \dots \pi)$, the pressure is increasing, and for $\varphi \in (\pi \dots 3\pi/2)$, pressure is considered constant.

In a point P of the circumference of gear z_1 , situated in range $\varphi \in (0 \dots \pi)$, the pressure created in the transported liquid to the discharge chamber is $p_{gz1} = p \cdot \varphi / \pi$. This pressure creates an elemental radial force dF_{r1} that acts on the external arc chord of the gear z_1 , corresponding to the angle $d\varphi$. Thus, the force is determined through relation (11):

$$dF_{r1} = p \cdot \frac{\varphi}{\pi} \cdot b \cdot \frac{D_c}{2} \cdot d\varphi \text{ [N]}. \quad (11)$$

The radial elemental force acting in range $\varphi \in (\pi \dots 3\pi/2)$ is:

$$dF_{r2} = p \cdot b \cdot \frac{D_c}{2} \cdot d\varphi \text{ [N]}. \quad (12)$$

On that basis, the total radial force F_{rx} that acts on direction $x-x$ on the gearing z_1-z_2 is calculated by relation (13):

$$F_{rx12} = p \cdot b \cdot \frac{D_{e12}}{2\pi} \int_0^\pi \varphi \cdot \cos \varphi d\varphi + p \cdot b \cdot \frac{D_e}{2} \int_\pi^{3\pi/2} \varphi \cdot \cos \varphi d\varphi \approx [\text{N}]. \quad (13)$$

$$0.81 \cdot p \cdot D_{e12} \cdot b$$

where φ – rotation angle of the driving gear z_1 , and D_{e12} – outer diameter of the gears calculated by relation (14):

$$D_{e12} = m \cdot (z_{12} + 2 + 2 \cdot \xi) [\text{mm}]. \quad (14)$$

The forces in gear mesh F_{rx1} and F_{rx2} acts on the same direction in gear centers O_1 and O_2 respectively, where the resultant forces F_{R1} and F_{R2} are considered to act.

According to Fig. 7, the radial forces acting on the shafts of gear z_1 and z_2 along direction $x-x$ is determined through relations (15) and (16) respectively:

$$F_{x1} = F_{rx1} - F_d = (0.81 \cdot z_1 - 0.38 + 1.62 \cdot \xi) \cdot p \cdot m \cdot b [\text{N}], \quad (15)$$

$$F_{x2} = F_{rx2} + F_d = (0.81 \cdot z_2 + 3.62 + 1.62 \cdot \xi) \cdot p \cdot m \cdot b [\text{N}]. \quad (16)$$

The radial forces acting along $y-y$ on both gears are equal to zero:

$$F_{y12} = p \cdot b \cdot \frac{D_{e12}}{2 \cdot \pi} \int_0^\pi \varphi \cdot \sin \varphi d\varphi + p \cdot b \cdot \frac{D_{e12}}{2} \int_\pi^{3\pi/2} \sin \varphi d\varphi = 0. \quad [17]$$

The radial rejection force F resultant of the teeth in contact is determined through relation (18):

$$F_y = F_d \cdot \text{tg} \alpha_w, [\text{N}] \quad (18)$$

where the meshing angle is $\alpha_w = 23^\circ$, the meshing being with addendum modification.

The resulting forces F_{R1} and F_{R2} that load the bearings of the driving and driven gears respectively are given by (19) and (20):

$$F_{R1} = p \cdot m \cdot b \cdot \sqrt{0.66 \cdot z_1^2 + 0.7 \cdot z_1 + 0.7} [\text{N}], \quad (19)$$

$$F_{R2} = p \cdot m \cdot b \cdot \sqrt{0.66 \cdot z_2^2 + 3.94 \cdot z_2 + 6.42} [\text{N}]. \quad (20)$$

For calculation of the forces according to the previous relations the following values were considered: $p = 150$ bar, $m = 2$ mm, $b = 3.5$ mm and $\xi = 0.5$ mm. Thus, the values are given below:

$F_d = 210$ N force applied on teeth;

$F_{rx1,2} = 1\,275$ N gearing forces loaded on the $x-x$ direction;

$F_{x1} = 1\,065$ N, $F_{x2} = 1\,475$ N radial forces loaded in the shafts axes O_1, O_2 ;

$F_y = 89$ N radial force as a reaction of the teeth being in contact;

$F_{R1} = 1\,071$ N, $F_{R2} = 1\,280$ N resultant forces that stress the shafts bearings.

The gearing forces are decomposed on two directions: tangential and radial (Fig. 7). To obtain the stresses and deformations values from the FEM analysis there were calculated the forces applied inside the gear pump, presented Fig. 7, using the following parameters for a certain pump variant: $p = 150$ bar (pressure assured by the pump), $m = 2$ mm and $b = 3.4$ mm.

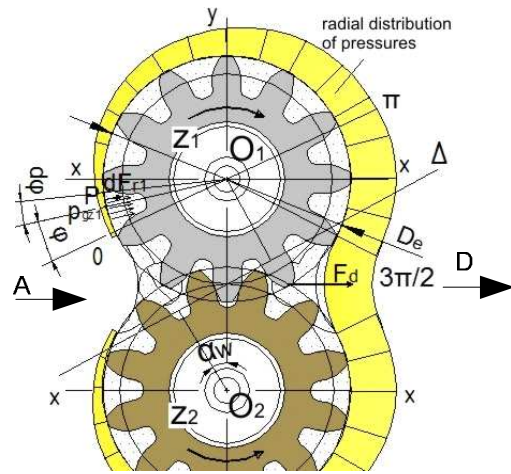

Fig. 6. Radial distribution of fluid pressures loaded on gearing.

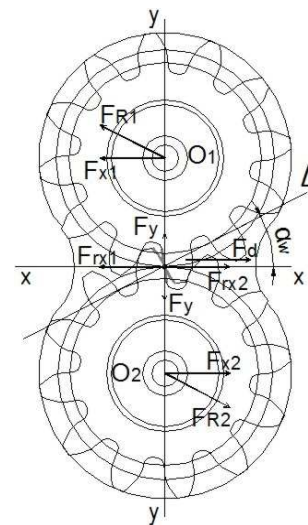

Fig. 7. Tangential and radial forces loaded on gearing and shafts.

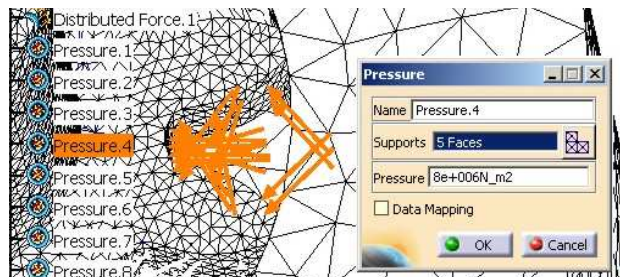

Fig. 8. Pressure distributed on teeth.

The pressure as a load is uniform and applied on a specific surface so that the direction of forces is perpendicular to that surface. The application of pressure is presented in Fig. 8 where there is a window for selecting the name of loading, indicating the surfaces on which it acts and also the field for inserting the pressure value.

The pressures are applied to each gear in the gap between teeth starting with a value of 1.5×10^6 N/m² up to 1.5×10^7 N/m² (150 bar), rated pressure. Pressures are increasing in radial distribution from the aspiration chamber to discharge one.

Figure 9 presents the application of forces on teeth in contact in FEM model.

Table 2

Maximum stress variations dependant of the error ratio

No.	Driving gear		Driven gear		Compensator		Body		Cover	
1	23.27%	9.93×10^7 N/m ²	22.39%	1.52×10^8 N/m ²	40.9%	9.09×10^6 N/m ²	29.87%	2.11×10^6 N/m ²	27.89%	1.04×10^7 N/m ²
2	18.7%	8.85×10^7 N/m ²	17.5%	1.56×10^8 N/m ²	14%	2×10^7 N/m ²	8.5%	3.43×10^6 N/m ²	9.02%	1.97×10^7 N/m ²

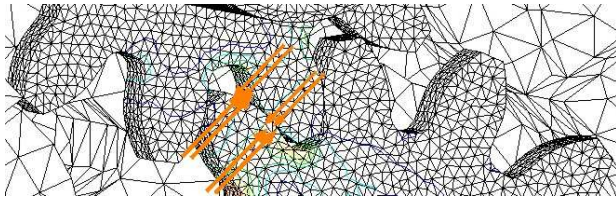
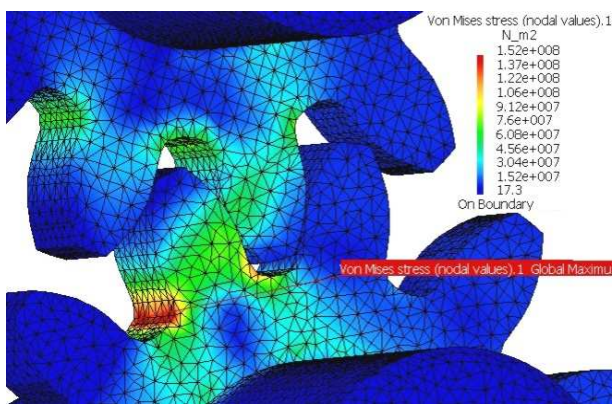
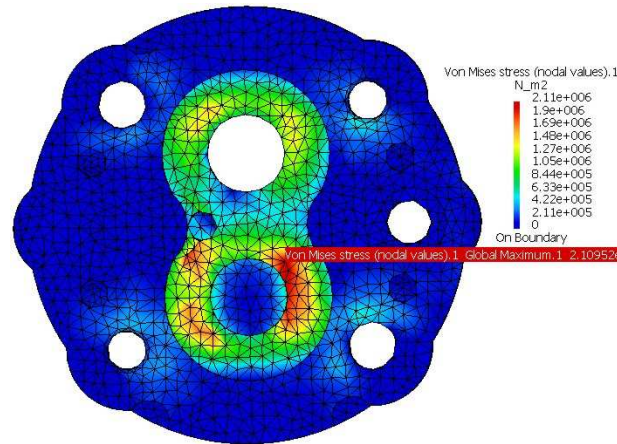

Fig. 9. Applying the tangential forces on the teeth in contact.



a



b

Fig. 10. Stresses distribution on the gearing teeth and on the pump body.

In Table 2, some results of the stresses variations for different pump parts are presented. The values contain a certain ratio of errors. In the finite elements practice, results with errors over 20% (set 1) are recommended to be recalculated. After a refinement of the parts meshes (increasing the number of the finite elements, changing their types – linear to parabolic) the FEM analysis was resumed, the final results are shown in the set 2.

Figure 10 presents the stresses distribution of the gears and body.

5. CONCLUSIONS

The stresses values are lower than the yield strengths of the parts materials, but the most loaded area is located at the teeth root on the driven gear. Also, from the FEM analysis results the forces values that load the bearings and gears: $F_x = 953$ N and $F_y = 63$ N, comparable with the calculated forces $F_{R2} = 1\,280$ N and $F_y = 89$ N (Fig. 7).

Thus, the application of the parametric CAD modeling and FEM analysis prove to be an efficient methodology to validate and improve a real constructive solution.

We can observe the stress distribution where the bigger values are on the driven gear bearings, in meshing zone and zones of the gap with maximum pressure. For the simulated assembly, the stress does not reach the admissible values of the used material, 2.6×10^8 N/m² for aluminium alloy.

The application of finite element simulation of the behavior of spur gear in operating conditions can continue with creation of sensors for each assembly component analysis. The role of sensors is to monitor tensions and deformations occurring in the component. They may impose the modification of some geometric parameters, functional or of material by using some parameterized rules.

REFERENCES

- [1] A. Ch. Chung, , *Simulation, Modeling. Handbook. A Practical Approach*. Industrial and manufacturing engineering series. CRC Press LLC, ISBN 0-8493-1241-8, Boca Raton London, New York Washington, 2004.
- [2] I. Ghionea, *Cercetări privind optimizarea prin simulare a concepției produselor industriale* (Researches on optimization by simulation of the industrial products design). Phd. Thesis, University Politehnica of Bucharest, 2010.
- [3] I.Ghionea, *Optimization approach to conception of a mechanical parts using CAD/FEM*, Scientific Bulletin of the University Politehnica of Bucharest, Series D, Vol. 71 (2009), Iss. 4, pp. 43–58.
- [4] N. Vasiliu, D. Vasiliu, *Acționări hidraulice și pneumatice. Vol. 1* (Hydraulic and pneumatic drives), Edit. Tehnică, Bucharest, 2005.
- [5] A. Oprean, *Hidraulica mașinilor-unelte*, Ediția a-III-a, Edit. Didactică și Pedagogică, Bucharest, 1983.
- [6] G. Constantin, *Bazele proiectării asistate* (Fundamentals of CAD), Edit. Bren, Bucharest, 2004.
- [7] D. Prodan, *Acționări hidraulice. elemente. subsisteme. sisteme* (Hydraulic drives. Elements. Subsystems. Systems), Edit. Printech, Bucharest, 2002.
- [8] ***, *Product Catalog HESPER, Pompe cu roți dințate* (Gear pumps), 2009.
- [9] ***, *Pompe și motoare hidraulice cu angrenaje* (Gear pumps and gear hydraulic motors), Hidraulica, U.M. Plopeni S.A, Romania, 2006.