

Geometry of the shoulder of a packaging machine

Citation for published version (APA):

Boersma, J., & Molenaar, J. (1995). Geometry of the shoulder of a packaging machine. *SIAM Review*, 37(3), 406-422. <https://doi.org/10.1137/1037084>

DOI:

[10.1137/1037084](https://doi.org/10.1137/1037084)

Document status and date:

Published: 01/01/1995

Document Version:

Publisher's PDF, also known as Version of Record (includes final page, issue and volume numbers)

Please check the document version of this publication:

- A submitted manuscript is the version of the article upon submission and before peer-review. There can be important differences between the submitted version and the official published version of record. People interested in the research are advised to contact the author for the final version of the publication, or visit the DOI to the publisher's website.
- The final author version and the galley proof are versions of the publication after peer review.
- The final published version features the final layout of the paper including the volume, issue and page numbers.

[Link to publication](#)

General rights

Copyright and moral rights for the publications made accessible in the public portal are retained by the authors and/or other copyright owners and it is a condition of accessing publications that users recognise and abide by the legal requirements associated with these rights.

- Users may download and print one copy of any publication from the public portal for the purpose of private study or research.
- You may not further distribute the material or use it for any profit-making activity or commercial gain
- You may freely distribute the URL identifying the publication in the public portal.

If the publication is distributed under the terms of Article 25fa of the Dutch Copyright Act, indicated by the "Taverne" license above, please follow below link for the End User Agreement:

www.tue.nl/taverne

Take down policy

If you believe that this document breaches copyright please contact us at:

openaccess@tue.nl

providing details and we will investigate your claim.

CASE STUDY FROM INDUSTRY

EDITED BY JACK W. MACKI

This section is dedicated to case studies which illustrate the applications of mathematics to contemporary industrial problems. Submissions of ten typed pages or less are preferred, but this limitation may be waived for articles of exceptional interest.

Submissions should be sent in triplicate to Jack Macki, Department of Mathematics, University of Alberta, Edmonton, Alberta, Canada T6G 2G1; e-mail: jmacki@vega.math.ualberta.ca; fax: (403) 492-6826. Authors are requested to provide e-mail and fax addresses, when possible, to facilitate efficient communication.

GEOMETRY OF THE SHOULDER OF A PACKAGING MACHINE*

J. BOERSMA[†] AND J. MOLENAAR[†]

Abstract. The shoulder of a packaging machine is a developable surface that guides the packing material without stretching or tearing. The shoulder is traditionally manufactured by bending a flexible plate along a given bending curve, also without stretching or tearing. In this paper, the shoulder geometry is described mathematically by methods from classical differential geometry. For a given bending curve the generating lines of the (developable) shoulder surface are completely specified. It is shown that the bending curve can be chosen such that the resulting shoulder contains a planar triangle. The special case of a conical shoulder is also discussed, and the underlying bending curve is determined explicitly.

Key words. developable surface, isometric mapping, generator, planar triangle, cone

AMS subject classifications. 53A05, 65Y25

1. Introduction. The research of this paper arose out of some questions from industry about the design of the so-called shoulder of a packaging machine. The shoulder is a surface that should guide the packing material (paper or plastic sheet) from a horizontal roll into a vertical circular cylinder where it is folded against the inner wall; see Fig. 1. Inside the cylinder the sheet is sealed at the bottom and at the front side to form a bag. The bag is filled from above by dropping the product to be packed, e.g., candy. Next, the bag is drawn downward, sealed at the top, and cut off, whereupon the process repeats itself. This process allows for packaging at high speed (hundreds of bags per minute), but is also sensitive to disturbances. In particular, the shape of the shoulder turns out to be quite critical. For a proper operation the shape should be such that the sheet is guided without stretching or tearing.

The shoulder can be manufactured in various ways. In the traditional manner, one starts from a thin rectangular plate of flexible material (metal or hard plastic), of width $2\pi R$, in which a so-called bending curve \overline{BC} is carved. The lower part of the plate (below \overline{BC}) is wrapped around a circular cylinder of radius R , whereby \overline{BC} passes into the curve BC on the cylinder. At the same time the upper part of the plate (above \overline{BC}) is bent backward to ultimately form the shoulder surface which is attached to the cylinder along BC . The original plate and its deformation into cylinder and shoulder are shown in Fig. 2. For a proper shoulder the deformation should be carried out very carefully, that is, without stretching or tearing.

The questions from industry concern the choice of the bending curve, so that the shoulder meets certain geometrical specifications regarding height, radius, angle between shoulder and cylinder, and others. In addition, use of a numerically controlled milling machine as an

*Received by the editors July 6, 1994; accepted for publication January 6, 1995.

[†]Department of Mathematics and Computing Science, Eindhoven University of Technology, Post Office Box 513, 5600 MB Eindhoven, The Netherlands.

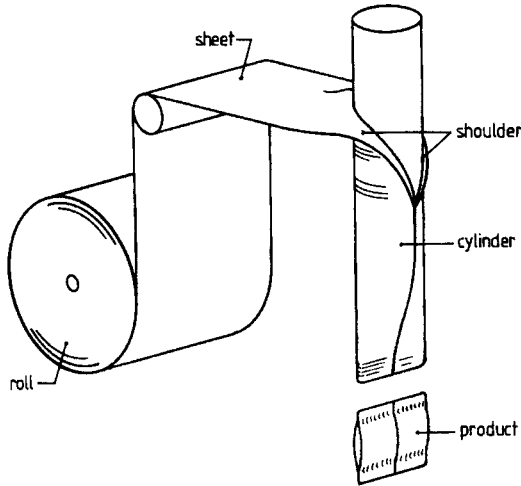

FIG. 1. Schematic drawing of the packaging machine.

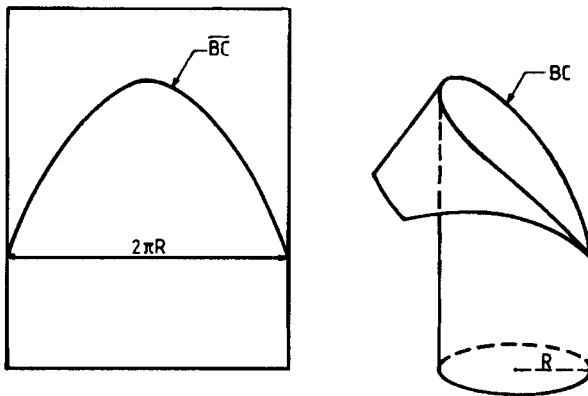

FIG. 2. Left: Rectangular plate of width $2\pi R$, with plane bending curve \overline{BC} . Right: Configuration of shoulder and cylinder of radius R , with bending curve BC .

alternative to the traditional manufacturing of the shoulder was considered. Both items require a detailed mathematical description of the shoulder geometry, which is the subject of this paper. From Fig. 1 it is seen that the packing material forms a planar sheet when approaching the shoulder. Therefore it is highly desirable that the shoulder surface be planar in the vicinity of the back edge. If not, the packing material and the shoulder do not perfectly fit and this might be a source of disturbance. So it was demanded (by industry) that the shoulder contain some planar piece.

In §2 of this paper we present the mathematical description of the shoulder geometry using methods from classical differential geometry. The shoulder is a developable surface that is completely determined by its generating lines. The bending curve is assumed to be three times continuously differentiable. Then the resulting shoulder is found to contain no planar pieces. In addition, we derive a specific condition on the bending curve which expresses that the shoulder is free of singularities. In §3 the analysis is extended to the case of a bending curve with a discontinuity in the third derivative. It is shown that the shoulder surface now

contains a planar triangle with its vertex at the discontinuity point. This feature can be fruitfully exploited to construct shoulders with a planar back edge. Section 4 deals with the question whether the shoulder surface could be part of a cone. By requiring that all generating lines pass through one point (vertex of the cone), we determine an explicit analytical representation for the bending curve of such a conical shoulder. In §5 we present a scheme for the calculation of the bending curve such that the corresponding shoulder meets certain prescribed specifications. A coordinate-dependent representation of the shoulder geometry is given in the Appendix.

This paper does not go into the mechanics of the transport of the packing material over the shoulder into the cylinder. The emphasis is on the analytical construction of the isometric mapping of the plane into the shoulder. The converse problem has been treated by Clements and Leon [1] and Kreyszig [5], who presented numerical procedures for the isometric mapping of a given developable surface into the plane.

2. Mathematical description of the shoulder geometry. The shoulder is manufactured by bending of a plane along the bending curve \overline{BC} , such that \overline{BC} deforms into the bending curve BC on a circular cylinder of radius R ; see Fig. 2. In the deformation (without stretching or tearing) all distances and angles in the surface are preserved, which means that the shoulder surface is isometric to the plane. Then it is known from differential geometry [3], [4], [7], that the shoulder must be a developable surface. Typical for a developable surface is the property that it contains a one-parameter family of straight lines, called generators, and along each generator the surface has a constant tangent plane. Thus the shoulder is completely determined by a specification of its generators. Furthermore, it follows from a result of Forsyth [3, p. 377] that, for given bending curves \overline{BC} (in the plane) and BC (on the cylinder), there exist two developable surfaces through BC , which are isometric to the plane through \overline{BC} , such that BC corresponds to \overline{BC} . Clearly one of these surfaces is the circular cylinder, while the other surface is the shoulder to be determined.

Throughout, we adopt the convention that corresponding quantities in the plane or on the shoulder are denoted by the same symbol with or without an overbar, respectively. The points of \overline{BC} and BC are represented by the two- and three-dimensional vectors $\bar{\mathbf{r}} = \bar{\mathbf{r}}(s)$ and $\mathbf{r} = \mathbf{r}(s)$, respectively, where the parameter s stands for arc length; this parameter is the same for \overline{BC} and BC because of isometry. In this section it is understood that $\bar{\mathbf{r}}(s)$ and $\mathbf{r}(s)$ are C^3 -functions, and \overline{BC} is concave. Differentiation with respect to s is denoted by a subscript s . We introduce the unit tangent vector $\bar{\mathbf{t}}$ and unit normal vector $\bar{\mathbf{n}}$ to \overline{BC} , given by

$$(1) \quad \bar{\mathbf{t}}(s) = \bar{\mathbf{r}}_s(s), \quad \bar{\mathbf{n}}(s) = -\bar{\mathbf{t}}_s(s)/\bar{\kappa}(s).$$

Likewise, the unit tangent, normal and binormal vectors to BC are given by

$$(2) \quad \mathbf{t}(s) = \mathbf{r}_s(s), \quad \mathbf{n}(s) = -\mathbf{t}_s(s)/\kappa(s), \quad \mathbf{b}(s) = \mathbf{t}(s) \times \mathbf{n}(s).$$

Here, $\bar{\kappa}$ and κ are the curvatures of \overline{BC} and BC , taken as

$$(3) \quad \bar{\kappa}(s) = |\bar{\mathbf{t}}_s(s)|, \quad \kappa(s) = |\mathbf{t}_s(s)|.$$

Since \overline{BC} is concave, the normal vector $\bar{\mathbf{n}}$ as defined in (1) points upward; see Fig. 3.

The shoulder is a developable surface containing a one-parameter family of generators. Hence, through each point $\mathbf{r}(s)$ of BC passes a generator of the shoulder. The direction of this generator is described by the unit vector $\mathbf{d}(s)$. The corresponding generator in the plane, through the point $\bar{\mathbf{r}}(s)$ of \overline{BC} , has a direction described by the unit vector $\bar{\mathbf{d}}(s)$. Now the vectors $\bar{\mathbf{d}}$ and \mathbf{d} are most conveniently expressed in terms of the orthonormal bases $\{\bar{\mathbf{t}}, \bar{\mathbf{n}}\}$ and $\{\mathbf{t}, \mathbf{n}, \mathbf{b}\}$, viz.

$$(4) \quad \bar{\mathbf{d}}(s) = \cos \alpha(s) \bar{\mathbf{t}}(s) + \sin \alpha(s) \bar{\mathbf{n}}(s),$$

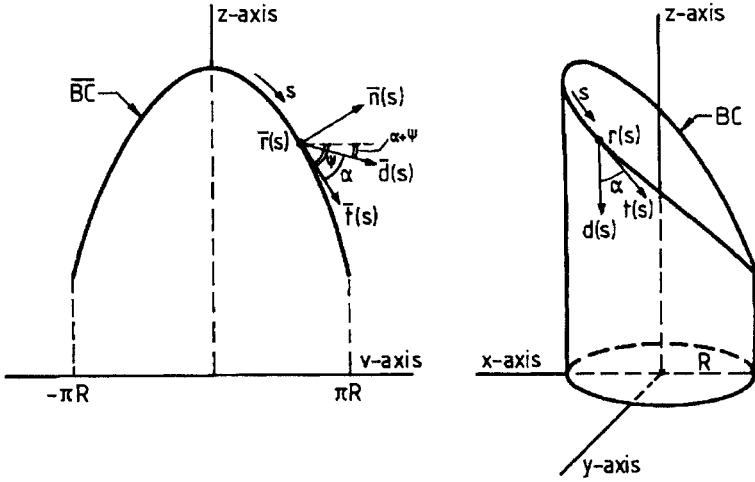

FIG. 3. *Left: Plane bending curve \overline{BC} represented by $\bar{r} = \bar{r}(s)$ or by $z = z(v)$; unit tangent vector $\bar{t}(s)$ and unit normal vector $\bar{n}(s)$ to \overline{BC} at $\bar{r}(s)$; generator $\bar{d}(s)$ at $\bar{r}(s)$; the angles ψ and $\alpha + \psi$ are negative. Right: Bending curve BC represented by $r = r(s)$; unit tangent vector $t(s)$ to BC at $r(s)$; shoulder generator $d(s)$ at $r(s)$.*

$$(5) \quad \mathbf{d}(s) = \cos \alpha(s)\mathbf{t}(s) + \sin \alpha(s)[\cos \varphi(s)\mathbf{n}(s) + \sin \varphi(s)\mathbf{b}(s)] ,$$

in which the angles $\alpha(s)$ and $\varphi(s)$ are yet to be determined. Note that the angle α between $\bar{\mathbf{d}}$ and $\bar{\mathbf{t}}$, and between \mathbf{d} and \mathbf{t} , is preserved because of the isometric correspondence; see Fig. 3.

For the plane above \overline{BC} and for the shoulder surface, we have the parametric representations

$$(6) \quad \bar{\rho} = \bar{\rho}(s, u) = \bar{r}(s) + u \bar{\mathbf{d}}(s) ,$$

$$(7) \quad \rho = \rho(s, u) = \mathbf{r}(s) + u \mathbf{d}(s) ,$$

where the parameter u stands for arc length along the generators. Next, we require that the mapping $\bar{\rho}(s, u) \rightarrow \rho(s, u)$ is isometric, i.e., the first fundamental forms of the surfaces should be the same at corresponding points [7, p. 175]. Thus we are led to the following conditions on the derivatives of $\bar{\rho}$ and ρ with respect to u and s :

$$(8) \quad (i) |\bar{\rho}_u| = |\rho_u| , \quad (ii) \bar{\rho}_u \cdot \bar{\rho}_s = \rho_u \cdot \rho_s , \quad (iii) |\bar{\rho}_s| = |\rho_s| .$$

Condition (i) is automatically fulfilled, since $\bar{\rho}_u = \bar{\mathbf{d}}$, $\rho_u = \mathbf{d}$ and $|\bar{\mathbf{d}}| = |\mathbf{d}| = 1$. Condition (ii) is also satisfied, because $\bar{\mathbf{d}} \cdot \bar{\mathbf{d}}_s = \mathbf{d} \cdot \mathbf{d}_s = 0$, hence $\bar{\rho}_u \cdot \bar{\rho}_s = \cos \alpha = \rho_u \cdot \rho_s$. In fact, we anticipated this condition by preserving α in (4) and (5). Condition (iii) requires that

$$(9) \quad |\bar{\mathbf{t}} + u \bar{\mathbf{d}}_s| = |\mathbf{t} + u \mathbf{d}_s| ,$$

which is equivalent to the three conditions

$$(10) \quad (iiia) |\bar{\mathbf{t}}| = |\mathbf{t}| , \quad (iiib) \bar{\mathbf{t}} \cdot \bar{\mathbf{d}}_s = \mathbf{t} \cdot \mathbf{d}_s , \quad (iiic) |\bar{\mathbf{d}}_s| = |\mathbf{d}_s| .$$

Condition (iiia) is trivially fulfilled. To satisfy conditions (iiib) and (iiic), we first evaluate the derivatives $\bar{\mathbf{d}}_s$ and \mathbf{d}_s . These are determined by use of the formulas of Serret–Frenet [7, p. 18] for \overline{BC} and BC , which read

$$(11) \quad \bar{\mathbf{t}}_s(s) = -\bar{\kappa}(s)\bar{\mathbf{n}}(s) , \quad \bar{\mathbf{n}}_s(s) = \bar{\kappa}(s)\bar{\mathbf{t}}(s) ,$$

$$(12) \quad \mathbf{t}_s(s) = -\kappa(s)\mathbf{n}(s), \quad \mathbf{n}_s(s) = \kappa(s)\mathbf{t}(s) + \tau(s)\mathbf{b}(s), \quad \mathbf{b}_s(s) = -\tau(s)\mathbf{n}(s).$$

Here, $\tau(s)$ is the torsion of BC , given by

$$(13) \quad \tau = \mathbf{t} \cdot (\mathbf{t}_s \times \mathbf{t}_{ss})/\kappa^2.$$

Then by differentiation of (4) and (5) with respect to s we readily find

$$(14) \quad \begin{aligned} \bar{\mathbf{d}}_s &= (-\alpha_s + \bar{\kappa})(\sin \alpha \bar{\mathbf{t}} - \cos \alpha \bar{\mathbf{n}}), \\ \mathbf{d}_s &= (-\alpha_s \sin \alpha + \kappa \sin \alpha \cos \varphi) \mathbf{t} \\ (15) \quad &+ [\alpha_s \cos \alpha \cos \varphi - \kappa \cos \alpha - (\varphi_s + \tau) \sin \alpha \sin \varphi] \mathbf{n} \\ &+ [\alpha_s \cos \alpha \sin \varphi + (\varphi_s + \tau) \sin \alpha \cos \varphi] \mathbf{b}, \end{aligned}$$

where the dependence on s has been suppressed. Conditions (iiib) and (iiic) can now be evaluated. It is easily recognized that condition (iiib) is satisfied for an angle $\varphi(s)$ determined by

$$(16) \quad \cos \varphi(s) = \bar{\kappa}(s)/\kappa(s).$$

It can be shown that BC on the shoulder and \overline{BC} in the plane have geodesic curvatures $\kappa \cos \varphi$ and $\bar{\kappa}$. Then (16) also follows from the property [4, p. 177] that corresponding curves on isometric surfaces have the same geodesic curvature at corresponding points. Condition (iiic) leads after some algebra to the following equation for the angle $\alpha(s)$:

$$(17) \quad \tan \alpha(s) = \frac{-\kappa(s) \sin \varphi(s)}{\varphi_s(s) + \tau(s)}, \quad 0 < \alpha < \pi.$$

This equation also follows by imposing the developability condition $\mathbf{t} \cdot (\mathbf{d} \times \mathbf{d}_s) = 0$ from [4, p. 182]. Both (16) and (17) were found earlier by Culpin [2], by a somewhat different approach.

Remark. So far it has not been used that BC lies on the cylinder. Therefore, (16) and (17) hold generally for the developable surface through an arbitrary space curve BC , that is isometric to the plane above \overline{BC} . It is readily seen that there exist two such developable surfaces, provided that $\bar{\kappa} < \kappa$, in accordance with the result of Forsyth [3, p. 377].

For BC on the cylinder it is obvious that $\bar{\kappa} < \kappa$, since the curvature increases when \overline{BC} is wrapped around the cylinder. The precise relation between $\bar{\kappa}$ and κ is given in (70) of the Appendix. As a consequence, (16) has two solutions, $\varphi = \varphi_1$ and $\varphi = \varphi_2$, with $0 < \varphi_1 < \pi/2$ and $\varphi_2 = 2\pi - \varphi_1$. The corresponding values of α , to be determined from (17), are denoted by α_1 and α_2 . On inserting the pairs (α_1, φ_1) and (α_2, φ_2) into (5), we find two generators passing through the point $\mathbf{r}(s)$ of BC , with directions to be denoted by $\mathbf{d}_1(s)$ and $\mathbf{d}_2(s)$, respectively. In the Appendix it is shown that the generator $\mathbf{d}_2(s)$ belongs to the circular cylinder, while the generator $\mathbf{d}_1(s)$ is contained in the shoulder surface. Hence, the solution pair (α_1, φ_1) of (16), (17) is to be used in (5), to find the generators of the shoulder. Then the shoulder surface is given by the parametric representation (7) with parameter $u \geq 0$. This completes the description of the shoulder geometry.

The developable surface $\rho = \rho(s, u)$ has a singularity at its edge of regression, along which two different sheets of the surface are tangent to each other [7, §2-4]. The edge of regression is determined by the property that the tangent vectors ρ_u and ρ_s are linearly dependent there. Using (16) and (17) in (15), we find that

$$(18) \quad \rho_s = \mathbf{t} + u \mathbf{d}_s = \mathbf{t} - u(\alpha_s - \bar{\kappa})[\sin \alpha \mathbf{t} - \cos \alpha (\cos \varphi \mathbf{n} + \sin \varphi \mathbf{b})],$$

while $\rho_u = \mathbf{d}$. The linear dependence of ρ_u and ρ_s is now expressed by the equation

$$(19) \quad \rho_u \times \rho_s = \{\sin \alpha - u(\alpha_s - \bar{\kappa})\}(\sin \varphi \mathbf{n} - \cos \varphi \mathbf{b}) = \mathbf{0},$$

with the solution

$$(20) \quad u = u_0(s) = \frac{\sin \alpha(s)}{\alpha_s(s) - \bar{\kappa}(s)}.$$

Thus the edge of regression is given by the parametric representation

$$(21) \quad \rho = \mathbf{r}(s) + u_0(s)\mathbf{d}(s)$$

with parameter s . For industrial practice it is imperative that the shoulder is free of singularities. Therefore we require that the edge of regression (21) does not lie on the shoulder surface. This leads to the condition $u_0(s) < 0$ or $\alpha_s - \bar{\kappa} < 0$. Let $\psi = \psi(s)$ be the signed angle between the tangent $\bar{\mathbf{t}}(s)$ to \overline{BC} and the positive v -axis in Fig. 3. Then $d\psi/ds = -\bar{\kappa}$ and the condition for a singularity-free shoulder becomes

$$(22) \quad \alpha_s(s) - \bar{\kappa}(s) = \frac{d}{ds}[\alpha(s) + \psi(s)] < 0.$$

Notice that $\alpha + \psi$ is the signed angle between the generator $\bar{\mathbf{d}}(s)$ and the positive v -axis in Fig. 3. The condition (22) expresses that $\alpha + \psi$ decreases with increasing s , hence, the generating lines through $\bar{\mathbf{d}}(s)$ are diverging and do not intersect. At the end of this section we shall translate (22) into a specific condition on the bending curve \overline{BC} ; see (30).

The unit normal \mathbf{N} to the developable surface $\rho = \rho(s, u)$ is taken as

$$(23) \quad \mathbf{N} = \frac{\rho_u \times \rho_s}{|\rho_u \times \rho_s|} = \sin \varphi \mathbf{n} - \cos \varphi \mathbf{b},$$

valid if $u \geq 0$ and $\alpha_s - \bar{\kappa} < 0$, in view of (19). Corresponding to $\varphi = \varphi_1$ and $\varphi = \varphi_2$, we employ the notations \mathbf{N}_1 and \mathbf{N}_2 for the normals to the shoulder and to the cylinder, respectively. Coordinate-dependent expressions for \mathbf{N}_1 and \mathbf{N}_2 are presented in (84) of the Appendix. The shoulder normal \mathbf{N}_1 points upwards (having a positive z -component), while the normal \mathbf{N}_2 to the cylinder points inwards. Next we determine the principal curvatures κ_1 and κ_2 of the developable surface by the standard method known from, e.g., [7, §§2-5, 2-6]. Omitting the details of the calculation, we find that

$$(24) \quad \kappa_1 = 0, \quad \kappa_2 = -\frac{\kappa \sin \varphi}{\sin \alpha} \frac{1}{\sin \alpha - u(\alpha_s - \bar{\kappa})},$$

with associated curvature directions along and perpendicular to the generators, respectively. For the shoulder we have $\kappa_2 < 0$, if the condition (22) is satisfied. This implies that the shoulder and its normal \mathbf{N}_1 lie on opposite sides of each tangent plane to the shoulder. Of special interest is the angle $\theta = \theta(s)$ between the tangent planes to the shoulder surface and to the cylinder, at the point $\mathbf{r}(s)$ of BC . Clearly, θ is equal to the angle between the normals \mathbf{N}_1 and $-\mathbf{N}_2$ as given by (23). Thus we have

$$(25) \quad \begin{aligned} \cos \theta &= -(\sin \varphi_1 \mathbf{n} - \cos \varphi_1 \mathbf{b}) \cdot (\sin \varphi_2 \mathbf{n} - \cos \varphi_2 \mathbf{b}) \\ &= 1 - 2 \cos^2 \varphi_1 = 1 - 2(\bar{\kappa}/\kappa)^2 \end{aligned}$$

by use of (16) and the relation $\varphi_2 = 2\pi - \varphi_1$.

In this section the description of the shoulder geometry is coordinate-free and in terms of arc length as the main parameter. In practice, it is often more convenient to represent \overline{BC} by an equation of the form $z = z(v)$, $-\pi R \leq v \leq \pi R$, where v, z are Cartesian coordinates in the plane; see Fig. 3. In the Appendix we present a coordinate-dependent description of the shoulder geometry in terms of the function $z(v)$ and its derivatives up to third order. From (71), (72), and (75) we quote the equations for the angles φ and α , pertaining to the shoulder surface:

$$(26) \quad \cos \varphi = -\frac{Rz_{vv}}{(R^2z_{vv}^2 + z_v^2 + 1)^{1/2}}, \quad \sin \varphi = \frac{(1 + z_v^2)^{1/2}}{(R^2z_{vv}^2 + z_v^2 + 1)^{1/2}},$$

$$(27) \quad \tan \alpha = -\frac{R^2z_{vv}^2 + z_v^2 + 1}{(2R^2z_{vvv} + z_v)(1 + z_v^2) - R^2z_vz_{vv}^2}, \quad 0 < \alpha < \pi.$$

Here the subscript v denotes differentiation with respect to v . Using (67) and (69) in (25), we find that the angle θ is determined by

$$(28) \quad \cos \theta = -\frac{R^2z_{vv}^2 - z_v^2 - 1}{R^2z_{vv}^2 + z_v^2 + 1}.$$

Finally, we come back to the condition (22). From the known values of $\tan \alpha$ and $\tan \psi = z_v$, we deduce that

$$(29) \quad \tan(\alpha + \psi) = z_v - \frac{R^2z_{vv}^2 + z_v^2 + 1}{2(R^2z_{vvv} + z_v)}.$$

Next we require that $(d/dv) \tan(\alpha + \psi) < 0$, equivalent to (22). Then by differentiation of (29) we obtain the specific condition

$$(30) \quad R^3z_{vvvv} + Rz_{vv} < 0$$

to be satisfied by the function $z(v)$, in order that the shoulder is free of singularities.

3. Shoulders containing a planar triangle. In this section we examine the effect of the plane bending curve \overline{BC} having a discontinuous third derivative at some point. It is shown that the corresponding shoulder surface contains a planar triangle with its vertex at the discontinuity point.

More specific, let \overline{BC} be described by $z = z(v)$, $-\pi R \leq v \leq \pi R$, where v, z are Cartesian coordinates in the plane; see Fig. 4. It is understood that $z(v)$ is a C^3 -function, except that the third derivative z_{vvv} is discontinuous at $v = 0$. For simplicity we take the function $z(v)$ to be even, i.e., $z(v) = z(-v)$, so that $z_v(0) = 0$, $z_{vvv}(0+) = -z_{vvv}(0-) \neq 0$. As before, \overline{BC} is deformed into the bending curve BC on the circular cylinder described by $x^2 + y^2 = R^2$, where x, y, z are Cartesian coordinates in \mathbb{R}^3 . The arc length s along \overline{BC} and BC is measured from the corresponding points $(0, z(0))$ of \overline{BC} , and $(R, 0, z(0))$ of BC .

From (1) and (2) it is clear that the unit vectors $\bar{\mathbf{t}}(s)$, $\bar{\mathbf{n}}(s)$ and $\mathbf{t}(s)$, $\mathbf{n}(s)$, $\mathbf{b}(s)$ are continuous functions of s even at $s = 0$, since these vectors depend on $z(v)$ and its first and second derivatives only. The angle $\varphi(s)$ is also continuous in s and its value at $s = 0$ is determined by (26). By (27), the angle $\alpha(s)$ depends on the third derivative z_{vvv} and is therefore discontinuous at $s = 0$. The right and left limits of $\alpha(s)$, to be denoted by $\alpha(0+)$ and $\alpha(0-)$, are determined by

$$(31) \quad \tan \alpha(0\pm) = -\frac{R^2z_{vv}^2(0) + 1}{2R^2z_{vvv}(0\pm)}, \quad 0 < \alpha(0\pm) < \pi.$$

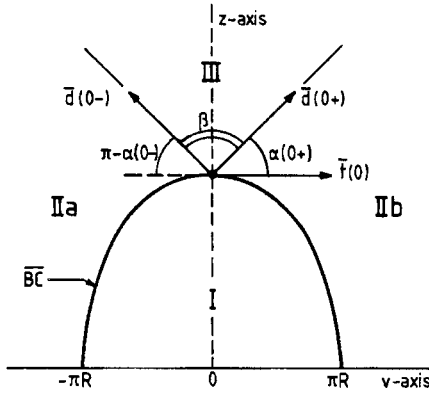

FIG. 4. Plane bending curve \overline{BC} described by $z = z(v)$, with z_{vvv} discontinuous at $v = 0$; unit tangent vector $\bar{\mathbf{t}}(0)$ to \overline{BC} and generators $\bar{\mathbf{d}}(0+)$ and $\bar{\mathbf{d}}(0-)$, at the point $(0, z(0))$.

Note that $\alpha(0-) = \pi - \alpha(0+)$ because of the symmetry of \overline{BC} . We now have two generators $\bar{\mathbf{d}}(0\pm)$ emanating from the point $(0, z(0))$ of \overline{BC} (see Fig. 4), and two generators $\mathbf{d}(0\pm)$ emanating from the point $(R, 0, z(0))$ of BC . According to (4) and (5) these generators are given by

$$(32) \quad \bar{\mathbf{d}}(0\pm) = \cos \alpha(0\pm)\bar{\mathbf{t}}(0) + \sin \alpha(0\pm)\bar{\mathbf{n}}(0) ,$$

$$(33) \quad \mathbf{d}(0\pm) = \cos \alpha(0\pm)\mathbf{t}(0) + \sin \alpha(0\pm)[\cos \varphi(0)\mathbf{n}(0) + \sin \varphi(0)\mathbf{b}(0)] .$$

From the scalar products

$$(34) \quad \bar{\mathbf{d}}(0-) \cdot \bar{\mathbf{d}}(0+) = \mathbf{d}(0+) \cdot \mathbf{d}(0-) = \cos(\alpha(0-) - \alpha(0+)) ,$$

we infer that the angles between $\bar{\mathbf{d}}(0-)$ and $\bar{\mathbf{d}}(0+)$, and between $\mathbf{d}(0-)$ and $\mathbf{d}(0+)$, are equal. Let the common angle be denoted by $\beta = \alpha(0-) - \alpha(0+) = \pi - 2\alpha(0+)$. Then, in virtue of (31), β is determined by

$$(35) \quad \tan(\beta/2) = -\frac{2R^2 z_{vvv}(0+)}{R^2 z_{vv}^2(0) + 1} ,$$

where it is understood that $z_{vvv}(0+) < 0$. Furthermore, we observe that

$$(36) \quad \sin \alpha(0-)\mathbf{d}(0+) - \sin \alpha(0+)\mathbf{d}(0-) = \sin(\alpha(0-) - \alpha(0+))\mathbf{t}(0) ,$$

which implies that the vectors $\mathbf{d}(0+)$, $\mathbf{d}(0-)$ and $\mathbf{t}(0)$ are coplanar.

Referring to Fig. 4, we divide the plane into the regions I, IIa, IIb, and III, separated by \overline{BC} and the generating lines through $\bar{\mathbf{d}}(0-)$ and $\bar{\mathbf{d}}(0+)$. Region I is wrapped around the circular cylinder $x^2 + y^2 = R^2$, whereby \overline{BC} deforms into BC . At the same time, regions IIa and IIb are bent backward to yield a two-part shoulder surface of the form described in §2. The two parts are bounded by BC and the generating lines through $\mathbf{d}(0-)$ and $\mathbf{d}(0+)$. The remaining region III is a triangle that fits exactly into the planar triangle bounded by the half-lines through $\mathbf{d}(0-)$ and $\mathbf{d}(0+)$, because both triangles have the same opening angle β . Thus we have shown that the complete shoulder surface contains a planar triangle with its vertex at the point $(R, 0, z(0))$, and opening angle β determined by (35). An example of such a shoulder is depicted in Fig. 5. The shoulder surface thus determined is smooth in

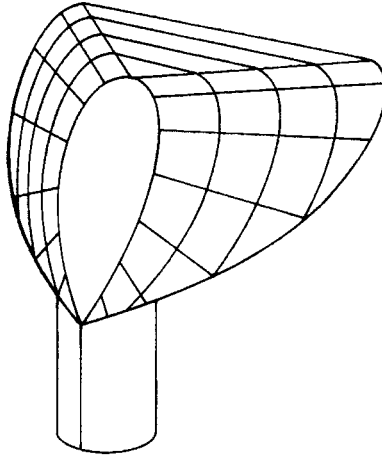

FIG. 5. Shoulder containing a planar triangle, with parameters $h/R = 6$, $\theta_0 = 90^\circ$, $\theta_1 = 10^\circ$, and $\beta = 90^\circ$.

the sense that it has a continuous tangent plane. To show this, we recall the property of a developable surface that along each generator the surface has a constant tangent plane. Along the generator $\mathbf{d}(s)$, the (constant) tangent plane to the shoulder is spanned by the vectors $\mathbf{d}(s)$ and $\mathbf{t}(s)$, and is therefore continuous in s for $s \neq 0$. At $s = 0$ we have two generators $\mathbf{d}(0+)$ and $\mathbf{d}(0-)$ emanating from the point $(R, 0, z(0))$, and the corresponding tangent planes are spanned by the pairs $(\mathbf{d}(0+), \mathbf{t}(0))$ and $(\mathbf{d}(0-), \mathbf{t}(0))$. Since the vectors $\mathbf{d}(0+)$, $\mathbf{d}(0-)$ and $\mathbf{t}(0)$ are coplanar, these tangent planes coincide with the planar triangle, which proves the continuity at $s = 0$. The angle θ_0 between the planar triangle and the tangent plane to the circular cylinder at the point $(R, 0, z(0))$ is determined by

$$(37) \quad \cos \theta_0 = -\frac{R^2 z_{vv}^2(0) - 1}{R^2 z_{vv}^2(0) + 1},$$

as obtained from (28).

4. Conical shoulders. From classical differential geometry it is known that a developable surface is a cylinder, a cone, or a tangential developable, that is, the surface generated by the tangent lines to a space curve (edge of regression); see e.g., [7, §2-4]. In this section we address the question for which bending curves the resulting shoulder surface is (part of) a cone. This question is of interest both from a mathematical viewpoint, and because Mot [6] has proposed a construction of shoulders that consist of two truncated cones connected by a planar triangle. In order to have a conical shoulder, all generators $\mathbf{d}(s)$ should pass through one point T , the vertex of the cone. Equivalently, the generators $\bar{\mathbf{d}}(s)$ in the plane should pass through a common point \bar{T} .

We employ Cartesian coordinates v, z , and x, y, z in the plane and in \mathbb{R}^3 , respectively. The plane bending curve \overline{BC} is described by

$$(38) \quad z = Rf(\xi), \quad \xi = v/R, \quad -\pi R \leq v \leq \pi R,$$

where $f(\xi)$ is a C^3 -function. Differentiation with respect to ξ is denoted by a prime. Two further conditions are imposed on $f(\xi)$: (i) $f(\pm\pi) = 0$; (ii) $f''(\xi) < 0$, so that \overline{BC} is concave. Referring to Fig. 6, we now require that all generators $\bar{\mathbf{d}}$ in the plane pass through the point \bar{T} with coordinates (Ra, Rb) , where $-\pi < a < \pi$, $b < f(a)$. At the point $(R\xi, Rf(\xi))$ of

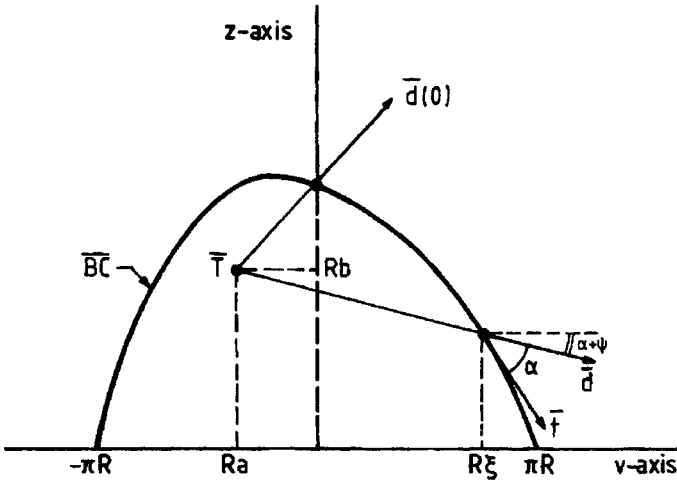

FIG. 6. Plane bending curve \overline{BC} described by $z = Rf(\xi)$, $\xi = v/R$, such that all generators \overline{d} pass through the point $\overline{T}(Ra, Rb)$; the angle $\alpha + \psi$ is negative.

\overline{BC} , the local generator \overline{d} makes an angle $\alpha + \psi$ with the positive v -axis. From (29) and (38) we infer that the angle $\alpha + \psi$ is determined by

$$(39) \quad \tan(\alpha + \psi) = f'(\xi) - \frac{(f''(\xi))^2 + (f'(\xi))^2 + 1}{2(f'''(\xi) + f'(\xi))}.$$

This expression is identified with the slope of \overline{d} , given by $(f(\xi) - b)/(\xi - a)$. Thus we are led to the following differential equation for the function f :

$$(40) \quad 2[f - b - (\xi - a)f'](f''' + f') + (\xi - a)(f''^2 + f'^2 + 1) = 0.$$

On multiplying (40) by f'' , the resulting equation may be integrated once, yielding

$$(41) \quad f''^2 + f'^2 + 1 = 2A[f - b - (\xi - a)f'],$$

where $A \neq 0$ is an arbitrary constant. Differentiation of (41) with respect to ξ leads to the simple differential equation

$$(42) \quad f''' + f' = -A(\xi - a).$$

The general solution of the differential equations (42) and (41) is easily found to be

$$(43) \quad f(\xi) = b - \frac{1}{2}A(\xi - a)^2 + B \cos \xi + C \sin \xi + \frac{1}{2A}(A^2 + B^2 + C^2 + 1),$$

where $A \neq 0$, B , C are arbitrary constants.

The present solution is of the same form as the solution by Mot [6, formula (6)]. In fact, it can be shown that Mot's solution is identical to (43) restricted by the additional condition $f'(0) = Aa + C = 0$. In Mot's approach, \overline{BC} is described by (38) with the function $f(\xi)$ given by (43) if $\xi > 0$, and by $f(\xi) = f(-\xi)$ if $\xi < 0$. Since $f'(0) = 0$, the even function $f(\xi)$ is a C^3 -function, except that $f'''(\xi)$ is discontinuous at $\xi = 0$. Mot then finds a shoulder surface consisting of two truncated cones, with different vertices, which are smoothly connected by a planar triangle. The latter feature is in conformity with the results of §3.

The solution (43), which is supposed to hold for $-\pi \leq \xi \leq \pi$, must satisfy the conditions (i) and (ii), stated below (38). By imposing condition (i): $f(\pm\pi) = 0$, we readily obtain

$$(44) \quad a = 0, \quad b = \frac{1}{2}A\pi^2 + B - \frac{1}{2A}(A^2 + B^2 + C^2 + 1).$$

Actually, the result $a = 0$ could have been anticipated. The line segments from \bar{T} to the endpoints $(\pm\pi R, 0)$ of \overline{BC} are both isometrically mapped on the line segment from T to the point $(-R, 0, 0)$ of BC . Hence, the endpoints of \overline{BC} have the same distance to \bar{T} , and \bar{T} must lie on the z -axis in Fig. 6.

By inserting the values of a and b , the solution (43) reduces to

$$(45) \quad f(\xi) = \frac{1}{2}A(\pi^2 - \xi^2) + B(\cos \xi + 1) + C \sin \xi, \quad -\pi \leq \xi \leq \pi,$$

in which $A \neq 0$, B , C are arbitrary constants. It remains to impose the condition (ii): $f''(\xi) = -A - B \cos \xi - C \sin \xi < 0$. Clearly, this condition is satisfied for all $\xi \in [-\pi, \pi]$, iff

$$(46) \quad A > \sqrt{B^2 + C^2}.$$

Also the assumption that $b < f(0)$ is fulfilled, since, by (44) and (45),

$$(47) \quad f(0) - b = B + \frac{1}{2A}(A^2 + B^2 + C^2 + 1) = \frac{1}{2A}((A + B)^2 + C^2 + 1) > 0.$$

Summarizing, we have shown that for the plane bending curve \overline{BC} described by (38) and (45), the generators $\bar{\mathbf{d}}$ in the plane pass through the point \bar{T} with coordinates $(0, Rb)$, where b is given by (44). The corresponding shoulder generators \mathbf{d} then pass through one point T , the vertex of the conical shoulder, which we shall now determine.

From (87) we infer that the shoulder generator \mathbf{d}_1 is proportional to the vector

$$(48) \quad \mathbf{D} = -f'' \mathbf{e}_1 - f''' \mathbf{e}_2 + [-f' f''' + \frac{1}{2}(f''^2 - f'^2 - 1)] \mathbf{e}_3,$$

expressed in terms of the function f and the basis vectors \mathbf{e}_1 , \mathbf{e}_2 , \mathbf{e}_3 with Cartesian components

$$(49) \quad \mathbf{e}_1 = (\cos \xi, \sin \xi, 0), \quad \mathbf{e}_2 = (-\sin \xi, \cos \xi, 0), \quad \mathbf{e}_3 = (0, 0, 1).$$

By use of (41) and (42) with $a = 0$, we rewrite

$$-f''' = A\xi + f',$$

and

$$-f' f''' + \frac{1}{2}(f''^2 - f'^2 - 1) = A\xi f' + \frac{1}{2}(f''^2 + f'^2 - 1) = A(f - b) - 1,$$

in (48), whereupon

$$(50) \quad |\mathbf{D}|^2 = f''^2 + (A\xi + f')^2 + [A(f - b) - 1]^2 = A^2[\xi^2 + (f - b)^2].$$

Next we observe that the distance between \bar{T} and the point $(R\xi, Rf(\xi))$ of \overline{BC} is given by $R[\xi^2 + (f(\xi) - b)^2]^{1/2}$. This distance is preserved in the isometric mapping and is therefore equal to the distance between the vertex T and the corresponding point $\mathbf{r}(\xi) = R\mathbf{e}_1 + Rf(\xi)\mathbf{e}_3$ of BC . Thus we conclude that the vertex T is represented by the position vector

$$(51) \quad \mathbf{r}(\xi) - \frac{R}{A}\mathbf{D} = \left(R + \frac{R}{A}f''(\xi)\right)\mathbf{e}_1 + \frac{R}{A}f'''(\xi)\mathbf{e}_2 + R\left(b + \frac{1}{A}\right)\mathbf{e}_3.$$

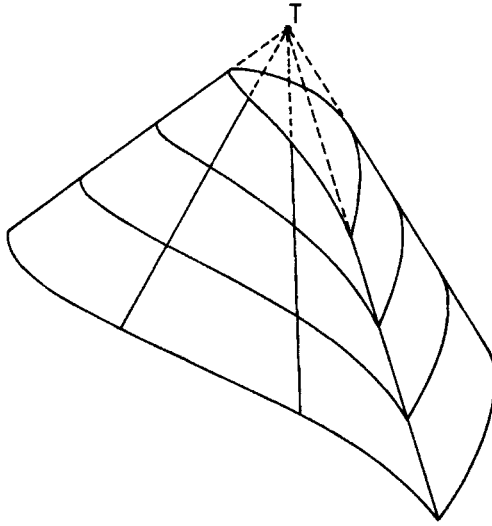

FIG. 7. Conical shoulder with vertex T , resulting from a parabolic bending curve \overline{BC} .

By inserting the values of $f''(\xi)$ and $f'''(\xi)$ from (45), we find that the vertex T has Cartesian coordinates

$$(52) \quad x_T = -RB/A, \quad y_T = -RC/A, \quad z_T = R(b + 1/A),$$

where b is given by (44).

In the industrial practice one sometimes starts from a parabolic bending curve \overline{BC} of height h , described by

$$(53) \quad z = z(v) = h[1 - (v/\pi R)^2], \quad -\pi R \leq v \leq \pi R.$$

The latter function is a special case of (45), corresponding to $A = 2h/\pi^2 R$, $B = 0$, $C = 0$. Thus the resulting shoulder will be part of a cone, depicted in Fig. 7, and the vertex of the cone is found to lie on the z -axis at height

$$(54) \quad z_T = h + \frac{\pi^4 R^2 - 4h^2}{4\pi^2 h}.$$

It seems that industrial designers have not been aware of this property so far.

5. Calculation of the bending curve. In this section we present an algorithm for the calculation of the plane bending curve \overline{BC} , such that the corresponding shoulder surface meets certain geometrical specifications. In practice, typical specifications concern the height h of the shoulder, its radius R , the angle θ_0 between the shoulder and the cylinder at the highest point, and the corresponding angle θ_1 at the lowest point of the shoulder. In addition, we require that the shoulder contains a planar triangle of opening angle β , with its vertex at the highest point of the shoulder.

Employing Cartesian coordinates v, z in the plane, we describe \overline{BC} by

$$(55) \quad z = Rf(\xi), \quad \xi = v/R, \quad -\pi \leq \xi \leq \pi,$$

where $f(\xi)$ is an even function given by

$$(56) \quad f(\xi) = c_0 + c_2\xi^2 + c_3|\xi|^3 + c_4(\cos \xi - 1 + \xi^2/2) + c_5|\sin \xi - \xi + \xi^3/6|,$$

subject to $f(\pi) = 0$. The present choice for $f(\xi)$, which is approximately a polynomial in ξ of degree five, is motivated by the form (45) for the bending curve of a conical shoulder. The coefficients c_0, c_2, c_3, c_4, c_5 in (56) are to be determined such that the associated shoulder meets the specifications mentioned above. In addition, we impose two further conditions on $f(\xi)$:

$$(57) \quad (i) \quad f''(\xi) < 0, \quad (ii) \quad f^{(4)}(\xi) + f''(\xi) < 0,$$

for $0 \leq \xi \leq \pi$. Here the prime denotes differentiation with respect to ξ . Condition (i) implies that \overline{BC} is concave, while condition (ii) stems from (30), expressing that the shoulder is free of singularities. The Ansatz (55), (56) gives rise to a sufficiently wide class of practically useful shoulders, although we have not examined the precise extent of this class. Neither did we look into the question for which parameter values $h, R, \theta_0, \theta_1, \beta$, the specifications and conditions can indeed be met. If not or if additional specifications are prescribed, the Ansatz (56) might be extended with higher-order terms to provide for extra degrees of freedom.

The shoulder is supposed to have its highest point at $\xi = 0$ and its lowest point at $\xi = \pm\pi$. Assigning the shoulder height h means that $f(0) = h/R$, from which we obtain

$$(58) \quad c_0 = h/R.$$

The coefficient c_2 is completely determined by the angle θ_0 at the highest point where $\xi = 0$. Indeed, from (37) it is found that

$$\cos \theta_0 = -\frac{(f''(0))^2 - 1}{(f''(0))^2 + 1} = -\frac{4c_2^2 - 1}{4c_2^2 + 1},$$

so that

$$(59) \quad c_2 = -\frac{1}{2} \left(\frac{1 - \cos \theta_0}{1 + \cos \theta_0} \right)^{1/2} = -\frac{1}{2} \tan(\theta_0/2).$$

The minus sign on the right has been deliberately chosen to make $f''(0) = 2c_2 < 0$.

The function $f(\xi)$ of (56) has a discontinuous third derivative at $\xi = 0$: $f'''(0\pm) = \pm 6c_3$. Then the resulting shoulder contains a planar triangle of opening angle β determined by (35) and (55), viz.

$$(60) \quad \tan(\beta/2) = -\frac{2f'''(0+)}{(f''(0))^2 + 1} = -\frac{12c_3}{4c_2^2 + 1}.$$

For given β , this relation determines the coefficient c_3 .

The remaining coefficients c_4 and c_5 follow from conditions to be imposed on $f(\xi)$ and its derivatives at $\xi = \pi$. First, the condition $f(\pi) = 0$ leads to a linear equation in c_4 and c_5 . Second, we require that $\theta = \theta_1$ at the lowest point ($\xi = \pi$), where θ is the angle between the tangent planes to the shoulder and to the cylinder. This angle is determined by (28), which we rewrite as

$$(61) \quad (f''(\xi))^2 - [(f'(\xi))^2 + 1] \tan^2(\theta/2) = 0.$$

By setting $\xi = \pi$ and $\theta = \theta_1$ in (61), and by inserting the values of $f'(\pi)$ and $f''(\pi)$ from (56), we are led to a quadratic equation in c_4 and c_5 . The two equations can be solved and we find at most one admissible solution for the pair (c_4, c_5) , such that $f'(\pi) < 0$ and $f''(\pi) < 0$. This completes the calculation of the plane bending curve \overline{BC} .

It remains to verify the conditions (57), evaluated as

$$(62) \quad f''(\xi) = 2c_2 + 6c_3\xi + c_4(1 - \cos \xi) + c_5(\xi - \sin \xi) < 0$$

and

$$(63) \quad f^{(4)}(\xi) + f''(\xi) = 2c_2 + c_4 + (6c_3 + c_5)\xi < 0,$$

for $0 \leq \xi \leq \pi$. By use of the known values of the coefficients c_2, c_3, c_4, c_5 , it can easily be checked whether or not the inequalities (62) and (63) are satisfied. If not, one could either modify the specifications or extend the Ansatz (56) with an additional term. As an example, we have carried out the calculation for the specifications $h/R = 6, \theta_0 = 90^\circ, \theta_1 = 10^\circ$, and $\beta = 90^\circ$. For the coefficients in (56) we found $c_0 = 6, c_2 = -0.5, c_3 = -0.167, c_4 = 0.986, c_5 = 0.596$. The resulting shoulder is shown in Fig. 5.

Appendix. Coordinate-dependent representation of the shoulder geometry. Introduce Cartesian coordinates v, z and x, y, z in the plane and in \mathbb{R}^3 , respectively; see Fig. 3. The plane bending curve \overline{BC} is described by $z = z(v), -\pi R \leq v \leq \pi R$, where $z(v)$ is a C^3 -function. Differentiation with respect to v is denoted by a subscript v . It is understood that $z_{vv} < 0$, so that \overline{BC} is concave. Next, \overline{BC} is wrapped around the circular cylinder $x^2 + y^2 = R^2$ in \mathbb{R}^3 , yielding the bending curve BC on the cylinder. The points of \overline{BC} and BC are now represented by the vectors $\bar{\mathbf{r}} = \bar{\mathbf{r}}(v)$ and $\mathbf{r} = \mathbf{r}(v)$, respectively, with Cartesian components

$$(64) \quad \bar{\mathbf{r}} = \bar{\mathbf{r}}(v) = (v, z(v)) ,$$

$$(65) \quad \mathbf{r} = \mathbf{r}(v) = (R \cos(v/R), R \sin(v/R), z(v)) .$$

The new parameter v is related to the arc length s by

$$(66) \quad \frac{dv}{ds} = (1 + z_v^2)^{-1/2} .$$

This relation is needed in the conversion of derivatives with respect to s into derivatives with respect to v .

We first determine the curvature κ and the torsion τ of BC by means of formulas adopted from Struik [7, p. 17]:

$$(67) \quad \kappa^2 = \frac{|\mathbf{r}_v \times \mathbf{r}_{vv}|^2}{|\mathbf{r}_v|^6} = \frac{R^2 z_{vv}^2 + z_v^2 + 1}{R^2(1 + z_v^2)^3} , \quad \kappa = \frac{(R^2 z_{vv}^2 + z_v^2 + 1)^{1/2}}{R(1 + z_v^2)^{3/2}} ,$$

$$(68) \quad \tau = \frac{\mathbf{r}_v \cdot (\mathbf{r}_{vv} \times \mathbf{r}_{vvv})}{|\mathbf{r}_v \times \mathbf{r}_{vv}|^2} = \frac{R^2 z_{vvv} + z_v}{R(R^2 z_{vv}^2 + z_v^2 + 1)} .$$

The curvature $\bar{\kappa}$ of \overline{BC} is given by

$$(69) \quad \bar{\kappa} = -z_{vv}/(1 + z_v^2)^{3/2} ,$$

where it is recalled that $z_{vv} < 0$, so that $\bar{\kappa} > 0$. The curvatures κ and $\bar{\kappa}$ are related by

$$(70) \quad \kappa^2 = \bar{\kappa}^2 + R^{-2}(1 + z_v^2)^{-2} ,$$

which shows that $\bar{\kappa} < \kappa$.

Next, by inserting (67) and (69) into (16), we find that the angle φ is determined by

$$(71) \quad \cos \varphi = \bar{\kappa}/\kappa = -\frac{Rz_{vv}}{(R^2z_{vv}^2 + z_v^2 + 1)^{1/2}}.$$

The latter equation has two solutions, $\varphi = \varphi_1$ and $\varphi = \varphi_2$, with $0 < \varphi_1 < \pi/2$ and $\varphi_2 = 2\pi - \varphi_1$. The corresponding values of $\sin \varphi$ are given by

$$(72) \quad \sin \varphi = \pm \frac{(1 + z_v^2)^{1/2}}{(R^2z_{vv}^2 + z_v^2 + 1)^{1/2}},$$

where the upper (lower) sign refers to $\varphi_1(\varphi_2)$; this convention is adopted throughout the Appendix. By differentiation of (71) with respect to s , using (66) and (72), we evaluate the derivative φ_s , viz.

$$(73) \quad \varphi_s = \pm \frac{R^2z_{vvv}(1 + z_v^2) - R^2z_vz_{vv}^2}{R(R^2z_{vv}^2 + z_v^2 + 1)(1 + z_v^2)}.$$

This value is inserted into (17), together with the values of κ , τ , and $\sin \varphi$ from (67), (68), and (72). As a result we are led to the following equation for the angle α :

$$(74) \quad \tan \alpha = -\frac{R^2z_{vv}^2 + z_v^2 + 1}{R^2z_{vvv}(1 + z_v^2) - R^2z_vz_{vv}^2 \pm (R^2z_{vv} + z_v)(1 + z_v^2)}, \quad 0 < \alpha < \pi.$$

By taking the upper (lower) sign in (74), we find that the corresponding angle $\alpha = \alpha_1$ ($\alpha = \alpha_2$) is determined by

$$(75) \quad \tan \alpha_1 = -\frac{R^2z_{vv}^2 + z_v^2 + 1}{(2R^2z_{vvv} + z_v)(1 + z_v^2) - R^2z_vz_{vv}^2}, \quad \tan \alpha_2 = \frac{1}{z_v}.$$

It is shown below that the pair of angles (α_1, φ_1) belongs to the shoulder surface, while the pair (α_2, φ_2) determines the generator of the circular cylinder.

Our second objective is to express the tangent, normal, and binormal vectors to BC , and subsequently the normal \mathbf{N} and the generator \mathbf{d} , in terms of the function $z(v)$ and its derivatives. At the point $\mathbf{r}(v)$ of BC we introduce the local orthonormal basis of vectors $\mathbf{e}_1, \mathbf{e}_2, \mathbf{e}_3$, with Cartesian components

$$(76) \quad \begin{aligned} \mathbf{e}_1(v) &= (\cos(v/R), \sin(v/R), 0), \\ \mathbf{e}_2(v) &= (-\sin(v/R), \cos(v/R), 0), \\ \mathbf{e}_3(v) &= (0, 0, 1). \end{aligned}$$

Differentiation of these vectors with respect to v , to be denoted by a prime, yields

$$(77) \quad \mathbf{e}'_1 = R^{-1}\mathbf{e}_2, \quad \mathbf{e}'_2 = -R^{-1}\mathbf{e}_1, \quad \mathbf{e}'_3 = \mathbf{0}.$$

In terms of the basis (76), the vector $\mathbf{r}(v)$ from (65) is represented by

$$(78) \quad \mathbf{r}(v) = R\mathbf{e}_1(v) + z(v)\mathbf{e}_3(v).$$

By differentiation of (78) with respect to s , using (66) and (77), we obtain the derivatives

$$(79) \quad \mathbf{r}_s = \mathbf{r}_v(1 + z_v^2)^{-1/2} = (1 + z_v^2)^{-1/2}\mathbf{e}_2 + z_v(1 + z_v^2)^{-1/2}\mathbf{e}_3,$$

$$(80) \quad \mathbf{r}_{ss} = -R^{-1}(1+z_v^2)^{-1}\mathbf{e}_1 - z_v z_{vv}(1+z_v^2)^{-2}\mathbf{e}_2 + z_{vv}(1+z_v^2)^{-2}\mathbf{e}_3.$$

From these results we conclude that the unit tangent, normal, and binormal vectors to BC are represented by

$$(81) \quad \mathbf{t} = \mathbf{r}_s = (1+z_v^2)^{-1/2}[\mathbf{e}_2 + z_v\mathbf{e}_3],$$

$$(82) \quad \mathbf{n} = -\mathbf{r}_{ss}/\kappa = (\kappa R)^{-1}(1+z_v^2)^{-2}[(1+z_v^2)\mathbf{e}_1 + Rz_v z_{vv}\mathbf{e}_2 - Rz_{vv}\mathbf{e}_3],$$

$$(83) \quad \mathbf{b} = \mathbf{t} \times \mathbf{n} = (\kappa R)^{-1}(1+z_v^2)^{-3/2}[-Rz_{vv}\mathbf{e}_1 + z_v\mathbf{e}_2 - \mathbf{e}_3],$$

where the curvature $\kappa = |\mathbf{r}_{ss}|$ is given by (67).

The expressions (82) and (83) are now inserted into (23), together with the values of κ , $\cos \varphi$, and $\sin \varphi$ from (67), (71), and (72). As a result we find the representation

$$(84) \quad \mathbf{N} = \frac{1}{R^2 z_{vv}^2 + z_v^2 + 1} \cdot [(-R^2 z_{vv}^2 \pm (1+z_v^2))\mathbf{e}_1 + (Rz_v z_{vv} \pm Rz_v z_{vv})\mathbf{e}_2 - (Rz_{vv} \pm Rz_{vv})\mathbf{e}_3]$$

for the unit normal \mathbf{N} to the developable surface. Corresponding to the upper (lower) sign in (84), we employ the notation \mathbf{N}_1 (\mathbf{N}_2) for the normal. It is readily seen that $\mathbf{N}_1 \cdot \mathbf{e}_3 > 0$, since $z_{vv} < 0$; hence, \mathbf{N}_1 has a positive z -component. Furthermore, $\mathbf{N}_2 = -\mathbf{e}_1$ is the inward normal to the cylinder $x^2 + y^2 = R^2$. To determine the generator \mathbf{d} , we rewrite (5) as

$$(85) \quad \mathbf{d} = \cos \alpha \mathbf{t} + \sin \alpha \mathbf{t} \times \mathbf{N}.$$

Then by use of (81) and (84) we are led to the representation

$$(86) \quad \begin{aligned} \mathbf{d} = & -\frac{(Rz_{vv} \pm Rz_{vv})(1+z_v^2)^{1/2}}{R^2 z_{vv}^2 + z_v^2 + 1} \sin \alpha \mathbf{e}_1 \\ & + (1+z_v^2)^{-1/2} [\cos \alpha - \frac{R^2 z_{vv}^2 \mp (1+z_v^2)}{R^2 z_{vv}^2 + z_v^2 + 1} z_v \sin \alpha] \mathbf{e}_2 \\ & + (1+z_v^2)^{-1/2} [z_v \cos \alpha + \frac{R^2 z_{vv}^2 \mp (1+z_v^2)}{R^2 z_{vv}^2 + z_v^2 + 1} \sin \alpha] \mathbf{e}_3. \end{aligned}$$

We first take the upper sign in (86) and set $\alpha = \alpha_1$, corresponding to the generator \mathbf{d}_1 . After dividing (86) by $\sin \alpha_1$, we replace the resulting $\cot \alpha_1$ on the right by its value from (75). Thus we obtain the representation

$$(87) \quad \begin{aligned} \frac{R^2 z_{vv}^2 + z_v^2 + 1}{2(1+z_v^2)^{1/2} \sin \alpha_1} \mathbf{d}_1 = & -Rz_{vv}\mathbf{e}_1 - R^2 z_{vvv}\mathbf{e}_2 \\ & + [-R^2 z_v z_{vvv} + \frac{1}{2}(R^2 z_{vv}^2 - z_v^2 - 1)]\mathbf{e}_3. \end{aligned}$$

By taking the lower sign in (86) and setting $\alpha = \alpha_2$, we find that the corresponding generator \mathbf{d}_2 is given by

$$(88) \quad \mathbf{d}_2 = (1+z_v^2)^{-1/2}[(\cos \alpha_2 - z_v \sin \alpha_2)\mathbf{e}_2 + (z_v \cos \alpha_2 + \sin \alpha_2)\mathbf{e}_3] = \mathbf{e}_3,$$

because of $\tan \alpha_2 = 1/z_v$ by (75). It is now clear that \mathbf{d}_2 lies along the circular cylinder $x^2 + y^2 = R^2$. Consequently, the generator \mathbf{d}_1 described by the angles α_1 , φ_1 , is contained in the shoulder surface.

Acknowledgments. The authors are indebted to Dr. H.W.M. Hendriks (Nijmegen) and the late Professor N.H. Kuiper (Utrecht) for helpful discussions. Figures 5 and 7 were copied from computer generated plots; here, the able assistance of Dr. C.W.A.M. van Overveld and Mr. J.W. Wesselink (Computer Graphics group, Eindhoven) is gratefully acknowledged.

REFERENCES

- [1] J. C. CLEMENTS AND L. J. LEON, *A fast, accurate algorithm for the isometric mapping of a developable surface*, SIAM J. Math. Anal., 18 (1987), pp. 966–971.
- [2] D. CULPIN, *A metal-bending problem*, Math. Scientist, 5 (1980), pp. 121–127.
- [3] A. R. FORSYTH, *Lectures on the Differential Geometry of Curves and Surfaces*, Cambridge University Press, Cambridge, 1912.
- [4] E. KREYSZIG, *Differential Geometry*, Dover, New York, 1991.
- [5] ———, *A new standard isometry of developable surfaces in CAD/CAM*, SIAM J. Math. Anal., 25 (1994), pp. 174–178.
- [6] E. MOT, *The “shoulderproblem” of forming, filling and closing machines for pouches*, Appl. Sci. Res., 27 (1973), pp. 1–13.
- [7] D. J. STRUIK, *Lectures on Classical Differential Geometry*, Dover, New York, 1988.