

CFD modeling and simulation of a hydropower system in generating clean electricity from water flow

Oladapo S. Akinyemi¹ · Yucheng Liu²

Received: 2 February 2015 / Accepted: 21 May 2015 / Published online: 10 June 2015
© The Author(s) 2015. This article is published with open access at Springerlink.com

Abstract In this study, electric generation capacity of a hydropower system was evaluated through computational fluid dynamics (CFD) modeling and simulation. Performance of paddle wheels in producing hydropower out of running water under different speeds was evaluated, and effects of side and bottom fins and paddle wheel shape on power generation were discussed based on the CFD results. It was also found that, compared to the regular straight paddles, the curved paddles can increase the electricity generation capacity of the entire system by 10–20 % at different water speeds. A preliminary economic analysis revealed the great prospects of applying the presented hydropower technology in regions with rich water resource to produce and supply low-cost, clean, and renewable electricity for a large amount of households and industries.

Keywords CFD · Paddle wheel · Hydropower · Bottom fin · Curved paddle

Introduction

In our previous study [1, 2], hydroelectric generation capacity of a paddle wheel had been evaluated through both analytical calculations and computational fluid dynamic

(CFD) simulations. Based on the outcomes, a hydropower system was fully developed, which consists of three pairs of paddle wheels and may include side and bottom fins to produce more hydropower out of running water. CFD modeling and simulation approach presented in [1, 2] was applied in this study to evaluate the performance of the developed system, and, based on the results, the potential impact of such system on energy industry and local economy was also estimated.

Because of its important role in generating electric power, the paddle wheel has been extensively employed in a rich variety of power plants to provide renewable and sustainable power generation. For example, paddle wheels will be used in a series of large concrete hydroelectric stations being constructed in the Belle Isle Strait, Canada [3]. Paddle wheel can also be found from the Rance River tidal power plant to generate electricity out of ocean energy [4]. In a microalgal biomass production station, paddle wheel is even mixing of ponds to achieve a required water velocity (20–25 cm/s) [5]. Several inventors also used paddle wheel as an important component in their designs of generating hydroelectricity out of water [6, 7].

In the present hydropower system, all the hydroelectricity is generated from paddle wheels. In real application, the full-sized hydropower system will be anchored in a river, and when the water passes through the equipment, it will rotate the paddle wheels to create very high torque at their axes. The rotating paddle wheels will then drive conventional electromagnetic generators to produce electric power. Such system includes three pairs of paddle wheel, which are arranged in series. The dimensions of original design are huge: $55 \times 36 \times 9 \text{ m}^3$, and two CFD models, the original model and a down scale (1:30) model, were created and used for simulations. In next phase, a

✉ Yucheng Liu
liu@me.msstate.edu

¹ Department of Mechanical Engineering, University of Louisiana at Lafayette, Lafayette, LA 70504, USA

² Department of Mechanical Engineering, Mississippi State University, Mississippi State, MS 39762, USA

Fig. 1 Geometry of a paddle wheel under water

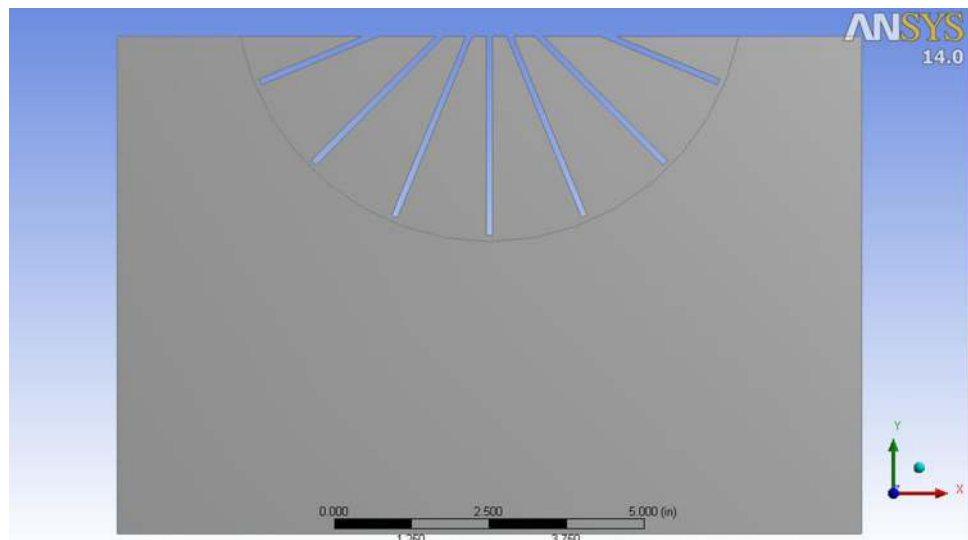

scaled prototype will be manufactured and used for experiments; the experimental results will then be compared to the simulation results to validate the employed computational approach.

CFD techniques have been extensively applied in design and assessment of hydro equipments, such as fluidized-bed reactors [8], structured packings [9], double turbine stirred tank [10], and reservoir [11]. However, in spite of the many CFD models created for other hydro equipments, only a few models have been created to simulate and assess paddle wheels. Peterson et al. [12] presented a methodology to simulate combinations of paddle wheels and propeller-aspirators in a single pond and showed from their simulations that a paddle wheel imparts more circulation into a pond than a propeller-aspirator of the same motor horsepower. Kang et al. [13] surveyed and simulated paddle-wheel-driven circulation in rectangular shrimp culture ponds using a 2D depth-integrated numerical model. Compared to the previous paddle wheel models, the modeling and simulation work presented in this study for the first time predicts the role of paddle wheels in a clean energy system using ANSYS CFD software packages. In addition to that, the computational results generated from this study provide a solid benchmark for the future experimental validation of the presented hydropower system.

Modeling and simulation of a single paddle wheel

In this section, the power generation capacity of an entire paddle wheel is calculated through the computer simulation. Software package ANSYS FLUENT and ANSYS Design-Modeler were used for modeling, analysis, and simulation. The paddle wheel consists of 16 paddles, and only 7 paddles are submerged into water at the same time.

Computer model

2D Computer-aided design (CAD) models for the paddle wheel and the moving water were first created, as shown in Fig. 1 (without bottom fin) and Fig. 2 (with bottom fin). In the generated computational environment, the physical domain was considered to be only the fluid part and the heat and mass transfer between the paddle wheel and water was neglected. The model consists of stationary and rotational reference frame, which were separated by circular boundary around the paddles.

The CAD model was then meshed, and cells were generated in the entire domain to create the CFD model. Quadrilateral mesh method was employed for meshing the model, and refinement was applied on edges of the paddles because it was expected that the results in those regions would vary very quickly and fine meshes were therefore necessary to accurately capture the variations [14]. Figures 3 and 4 display meshed paddle wheel model without and with bottom fins, which have 4668 cells and 7243 cells, respectively. In the meshed CFD model, the essential fluid flows were described through these cells, which would be solved numerically, so that the discrete values of the flow properties such as the velocity, pressure, temperature, and other transport parameters of interest can be determined [15].

CFD analysis

The maximum angular velocity is calculated with respect to that the net generated torque on the wheel shaft becomes zero. In another word, when the wheel is rotating by maximum angular velocity, the torque exerting on the paddles is zero. Following this manner, overall 30 simulations are performed. Table 2 illustrates important algorithms, approximations, and other settings.

Fig. 2 Geometry of a paddle wheel under water with bottom fin

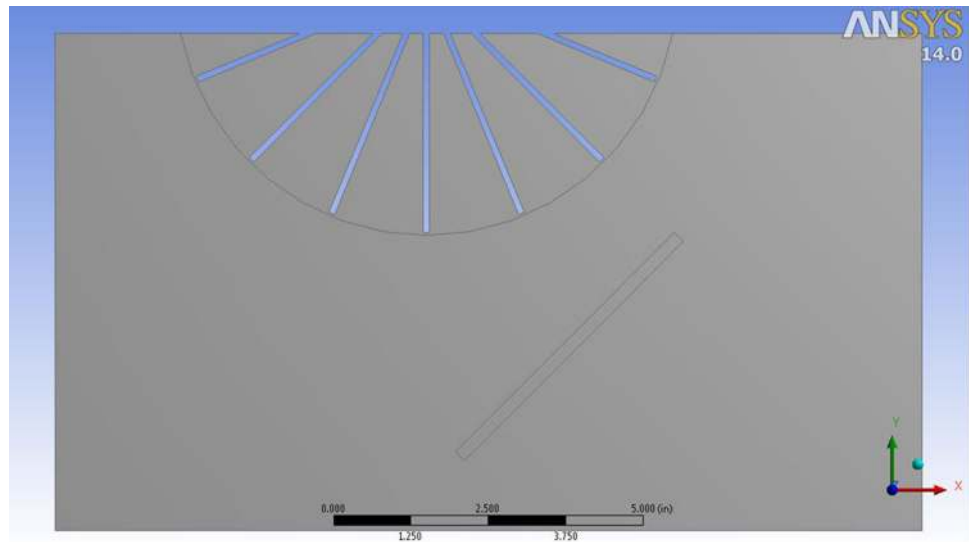
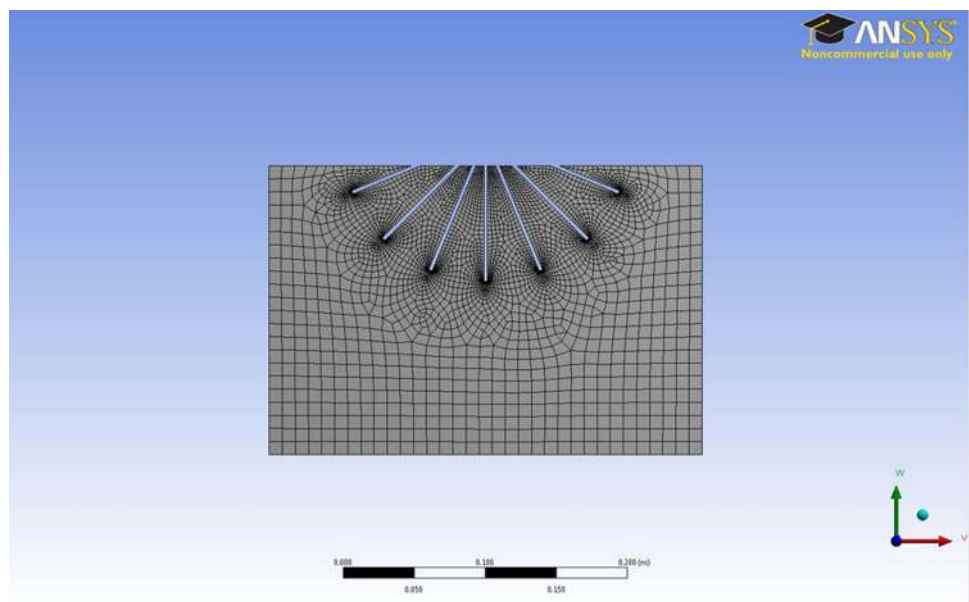

Fig. 3 Meshes of a paddle wheel without bottom fin



Water speeds of 1.8, 2.2, 2.7, 3.6, and 4.5 m/s were defined in this model and used for CFD analyses to find the hydropower electricity generation capacity of the paddle wheel. Those speeds were selected as typical water speeds attainable at Wax Lake in State of Louisiana, United States (a candidate site for deployment of the presented system), and those values were provided by a local agency. At each water speed, six equally increased angular velocities from 0 to a maximum value were applied on the paddle wheel and used for simulation. The maximum angular velocity was calculated as when the net generated torque on the wheel shaft became zero. Overall 30 simulations were carried out.

Table 1 illustrates important algorithms, approximations, and other settings used for the analyses.

Simulation results

Figures 5, 6, 7, and 8 display the distribution of the pressure and water velocity around a stationary paddle wheel with and without the bottom fin at a water speed of 1.8 m/s,. From these figures, it can be seen that the majority of the force is applied on the left four paddles through the flow, while other paddles were indispensable in making a continuous rotation. It is also obvious that the left four paddles

Fig. 4 Meshes of a paddle wheel with bottom fin

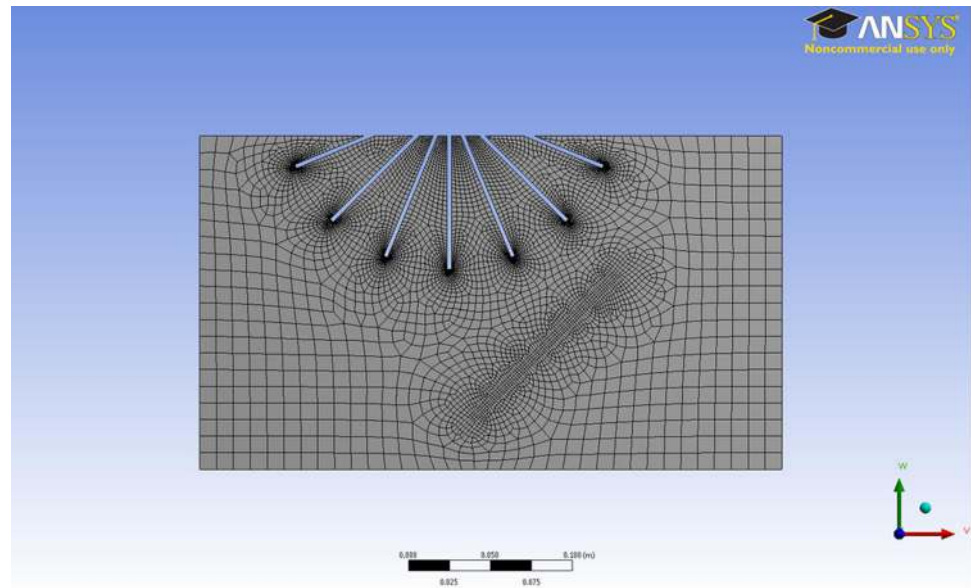

Table 1 Important CFD analysis settings

Solver type	Pressure based, double precision, steady state, 2D
Viscose model	$k-\varepsilon$ realizable with standard wall function
Fluid	Water with density of 998 kg/m^3
Rotation	Multiple reference frame model
Pressure–velocity coupling	Coupled
Gradient discretization	Least square cell based
Pressure discretization	Standard
Momentum discretization	Second-order upwind
Turbulent kinetic energy discretization	Second-order upwind
Turbulent dissipation energy discretization	Second-order upwind
Boundary condition	Velocity inlet and ambient pressure outlet

created most power because of the high pressure and high velocity around them.

CFD simulation of the hydropower system

After successfully running CFD simulation for a single paddle wheel, the entire hydropower system CFD model was created, on which simulations were performed (Fig. 9). During the simulation, water would pass through three pairs of paddle wheels in sequence; therefore, the water speed profile would change after passing a pair of paddle wheels and would then affect the power generation of the next pair of paddle wheels. As shown in Fig. 10, the water speed profile at outlet of the first paddle wheel is not uniform. Such speed profile will then be applied at inlet of the second pair of paddle wheels. A flowchart (Fig. 11) is

presented here to show the procedure of assessing the entire hydropower system.

Power generated by the hydropower system at different water speeds is listed in Table 2 (without bottom fin) and Table 3 (with bottom fin), along with the contribution from each pair of paddle wheels. From both tables, it can be found that the first pair of paddle wheels produces majority of hydropower and the power generated by the following two pairs of paddle wheels decreases subsequently. The results also confirm significant effect of bottom fins on improving the power generation capacity of the paddle wheels. During the simulation, the bottom fins captured energy in deep water and carried that energy directly to the paddle wheels. As shown in Tables 2 and 3, without bottom fins, only first two pairs of paddle wheels generated hydropower, but after applying bottom fins, even the third pair of paddle wheels produced 8–10 % of hydropower at



Fig. 5 Pressure distribution around the paddle blades without bottom fin, water speed = 1.8 m/s

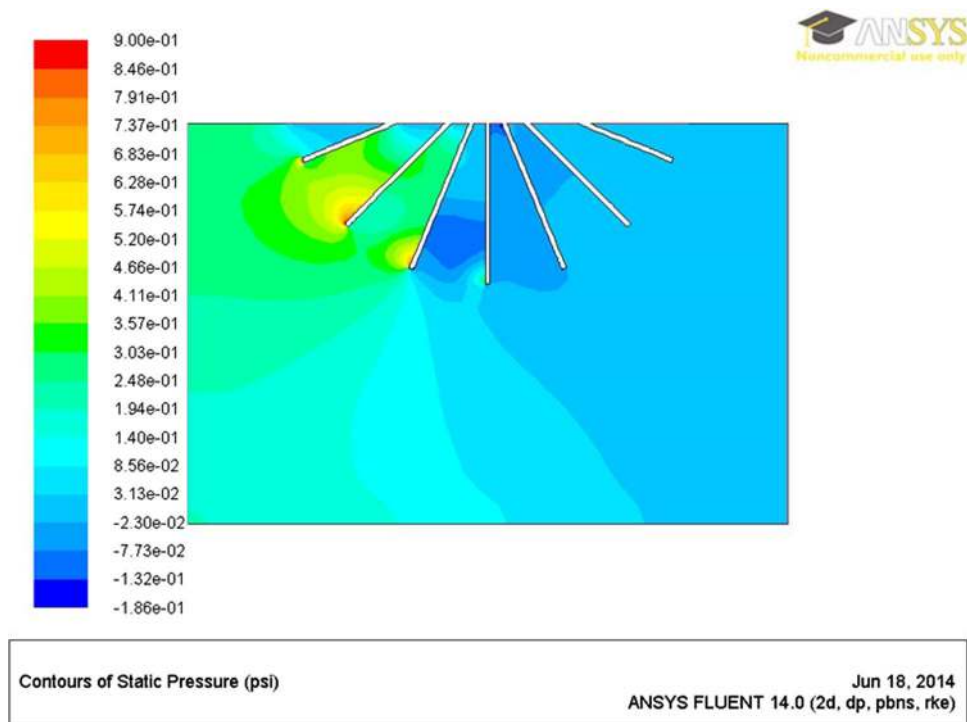
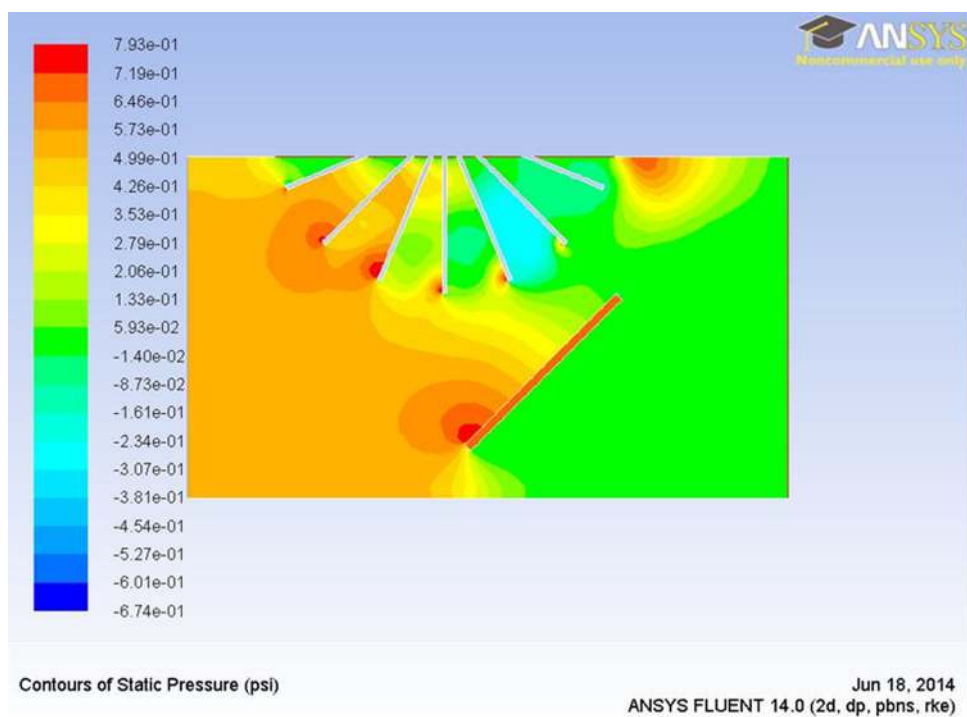

Fig. 6 Pressure distribution around the paddle blades and bottom fin, water speed = 1.8 m/s



different water speeds. Moreover, the application of bottom fins dramatically improved the overall produced hydropower by 2.7 to about 4 times at different water speeds (as seen in Table 4).

It is evident that the bottom fins enhance the overall performance of the entire hydropower system.

Evaluation of curved paddles

From the simulation results of the present design, it was found that paddle wheels are the elements that convert the flow energy to mechanical energy and bottom fins have the major effect in hydropower generation.

Fig. 7 Velocity profile of water around the paddle blades, water speed = 1.8 m/s

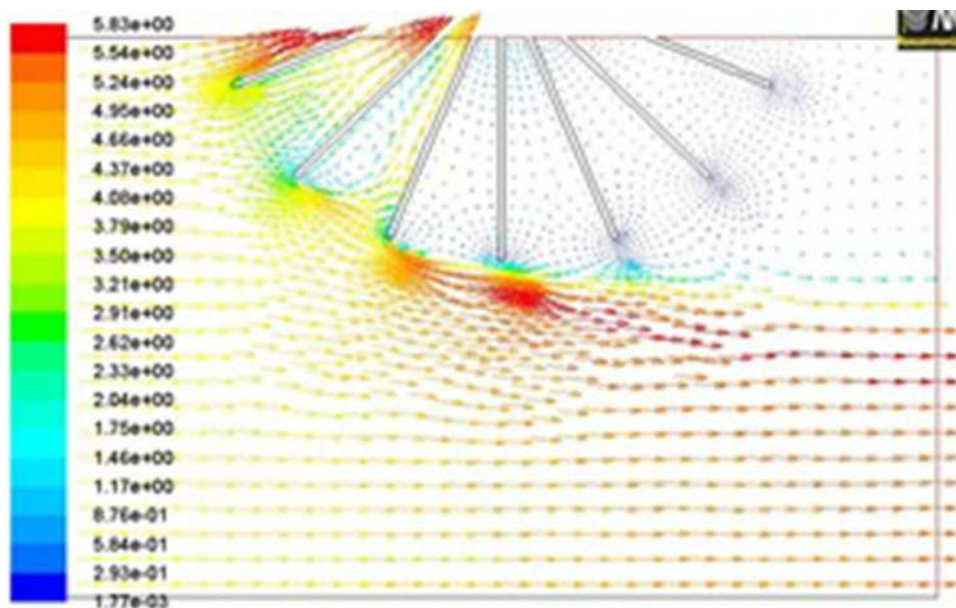
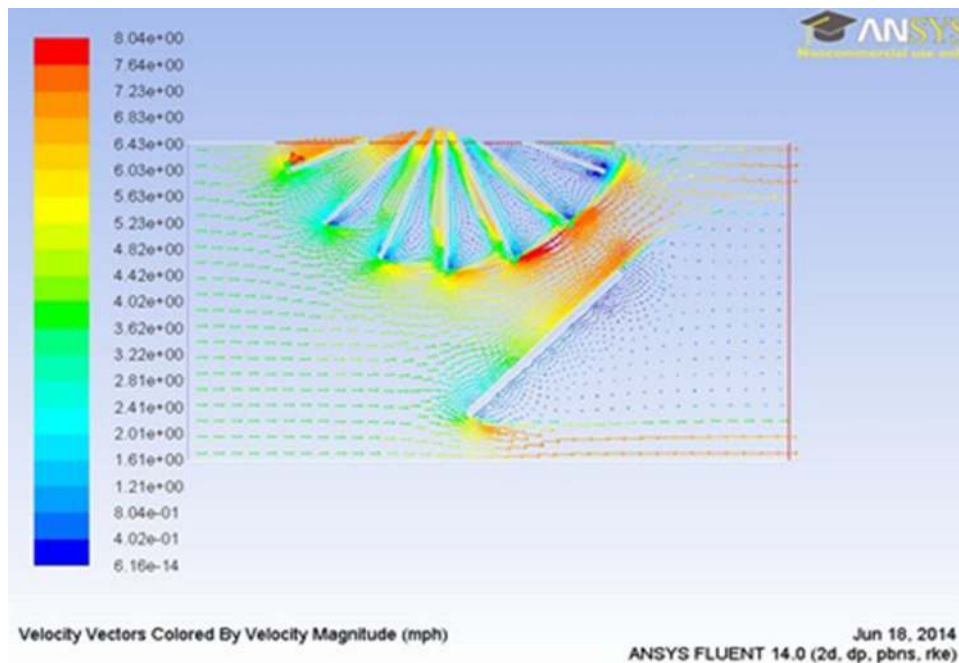

Fig. 8 Velocity profile of water around the paddle blades and fin, water speed = 1.8 m/s



Originally, the paddles are flat plates and it was hypothesized that the shape of paddle wheels can be curved to bring more water flow running through the hydropower system to generate more power and also to reduce the energy loss as a result of sudden change in flow direction [16]. In optimizing the shape of the fins, Bejan's constructal law as well as Lorenzini's work was also referred to [17–20].

As suggested by Bansal [16], the optimized blade was developed such that the curvature begins at the 3" length radius of the blade from the center of the paddle wheel with a radius of curvature of 1.07". The starting position of 3" length was chosen in order to guarantee that there are at least seven paddles submerged into water at any time. Specifically, the curvature was made along the direction of the water flow because it would increase the



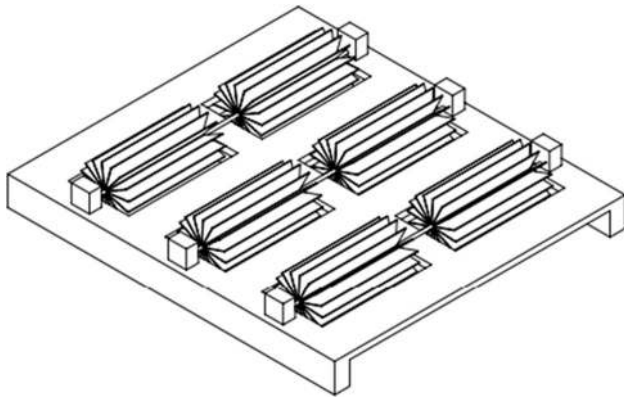

Fig. 9 3D sketch of the entire hydropower system

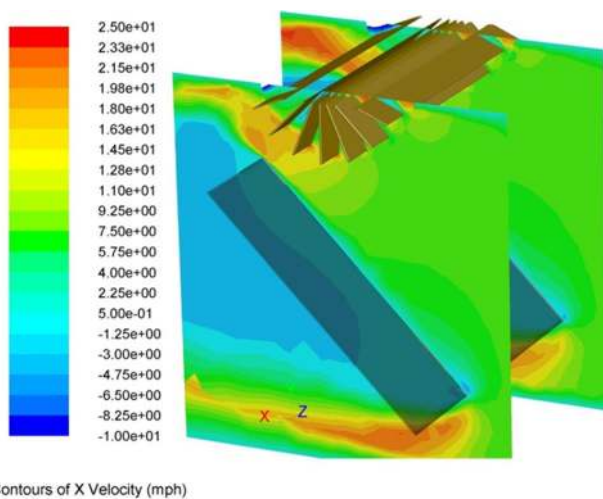

Fig. 10 Water speed contour at outlet of the first paddle wheel, water speed = 3.6 m/s

overall torque and therefore improve the generated hydropower. Figure 12 illustrates the optimized CFD model. The optimized model was then validated through the same CFD simulation, and as compared in Table 5, comparing to the original model with flat paddles and fins, the optimized model evidently enhanced the hydropower generation from about 10–20 % at different water speeds.

This work only represents an initial effort in shape optimization of the blade paddles. To achieve an optimal shape of the blade paddle that maximizes the hydropower generation capacity, a full-scale optimization study has to be conducted, where the blade number, blade length, and curvature of the blades should be defined as design variables, whose influence on the overall performance of the present hydropower system needs to be examined.

CFD simulation of the down scale model

The full-size design of the hydropower system is too huge to be used for experimental validation. Thus, 1:30 down scale models were created and used for the same simulations, and the results will be compared to the experimental data measured from tests to validate the employed computational approach as well as to verify the potential of implementation and commercialization of the proposed hydropower technology. Three CFD models were created for simulations: the original scaled hydropower system without bottom fins, with bottom fins, and the optimized system with bottom fins. The overall produced hydropower from the three models at five different water speeds was recorded and compared, as shown in Table 6. As can be seen from that table, the relationship among the power generated from the three down scale models is very close to that from the three original-size models.

Economic analysis

A primary economic analysis was performed based on the computer results. Based on the results listed in Table 3, the total electricity generated annually from one such system under different water speeds was estimated and displayed in Table 7. The initial investment for manufacturing the system, purchasing and installing generators, controllers, and inverters was estimated at about \$8.2 million. Assuming an annual average water speed of 3.2 m/s, the total generated hydroelectricity may reach 25 GWh, and considering the renewable energy credits of \$11 for every 1000 kWh renewable electricity generated, which is offered by the federal government, the total annual income is close to \$1.8 million at the average water speed if the generated electricity is sold at \$0.06/kWh. Thus, the assumed payback period is about four and half years. After the payback period, the cost for the electricity will be reduced to \$0.02/kWh to cover basic maintenance and labor fee. Considering the household electricity consumption, the amount of 25 GWh electricity can benefit about 1645 households.

Economic analysis results suggest the great prospects of applying the presented hydropower technology in regions with rich water resource to produce and supply low-cost, clean, and renewable electricity for a large amount of households and industries. Full implementation of such technology will lead to the establishment of many run-of-the-river hydroelectric power stations, in turn will create thousands of manufacturing, construction, supply, and maintenance jobs.

Fig. 11 Hydropower system simulation algorithm

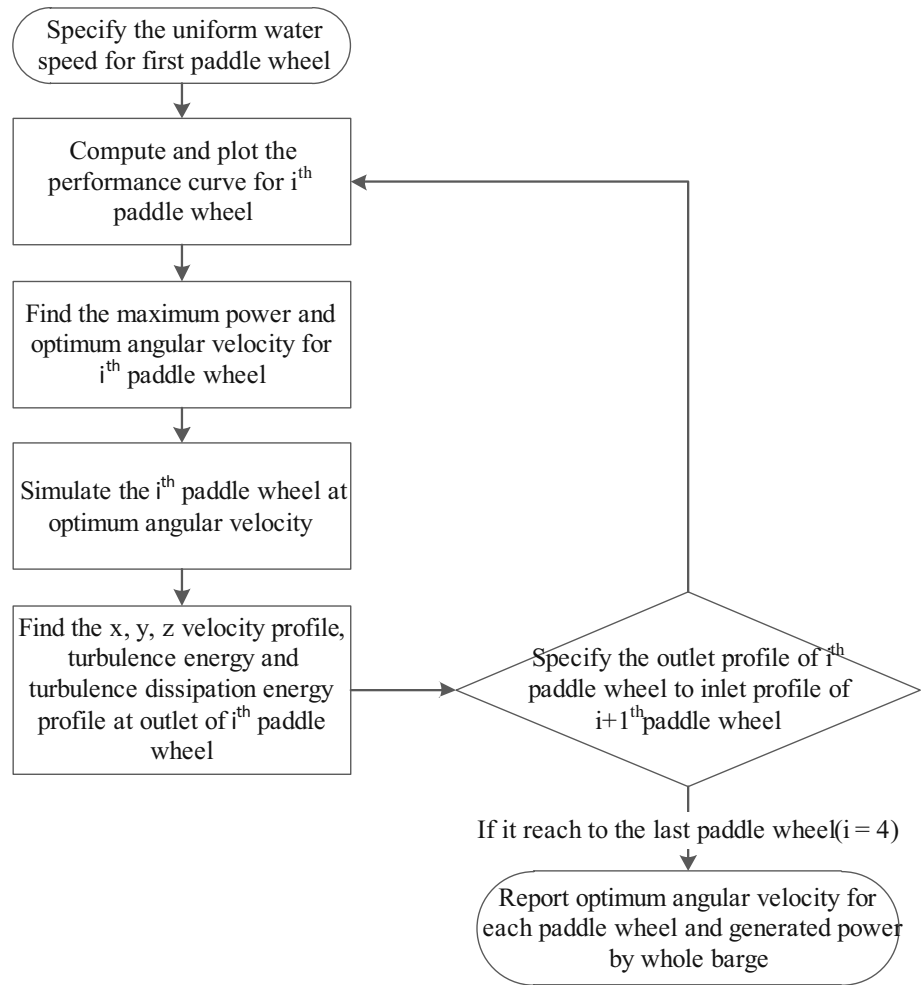

Table 2 Barge-produced power and contribution of each paddle wheel (without bottom fin)

Water speed (m/s)	Power (kW)	First pair (%)	Second pair (%)	Third pair (%)
1.8	185.4	69.4	29.3	1.3
2.2	318.3	71.3	27.8	0.9
2.7	502.5	71.7	27.4	0.9
3.6	1025.0	70.9	28.3	0.8
4.5	1740.0	71.7	27.5	0.8

Table 3 Barge-produced power and contribution of each paddle wheel (with bottom fin)

Water speed (m/s)	Power (kW)	First pair (%)	Second pair (%)	Third pair (%)
1.8	506.9	63.2	26.7	10.1
2.2	943.0	64.9	25.3	9.8
2.7	1589.8	65.2	24.9	9.9
3.6	3620.2	65.2	26.0	8.8
4.5	6838.1	66.0	25.8	8.2

Table 4 Effects of bottom fins in hydropower generation

Water speed (m/s)	No bottom fin (kW)	With bottom fins	Optimized model
1.8	185.4	506.9 kW (173.4 %)	605.5 kW (226.6 %)
2.2	318.3	943.0 kW (196.3 %)	1098.8 kW (245.2 %)
2.7	502.5	1589.8 kW (216.4 %)	1823.1 kW (262.8 %)
3.6	1025.0	3620.2 kW (253.2 %)	4041.6 kW (294.3 %)
4.5	1740.0	6838.1 kW (293.0 %)	7482.0 kW (330 %)

Fig. 12 Optimized CFD hydropower system model with curved paddles

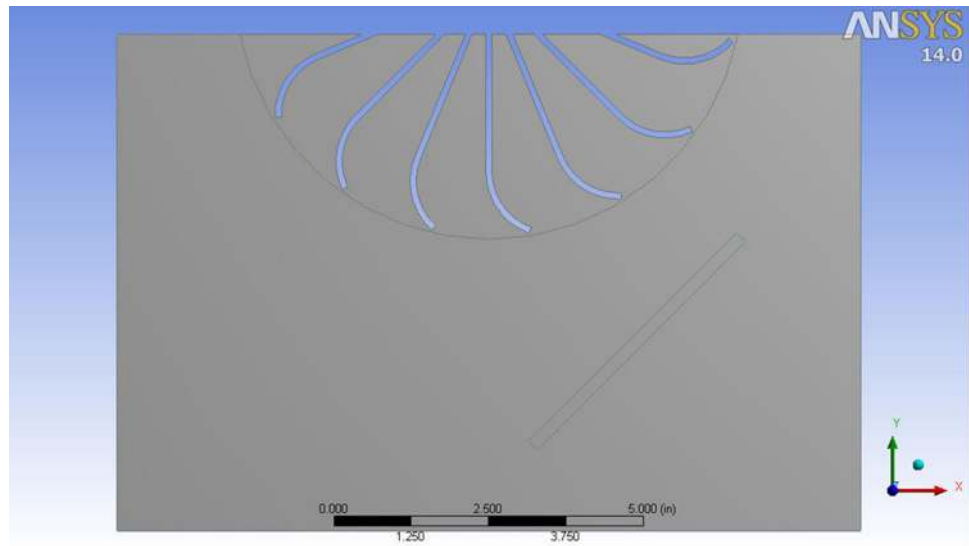

Table 5 Comparison of original hydropower system and optimized model (with bottom fins)

Water speed (m/s)	With bottom fins (kW)	Optimized model
1.8	506.9	605.5 kW (19.5 %)
2.2	943.0	1098.8 kW (16.5 %)
2.7	1589.8	1823.1 kW (14.7 %)
3.6	3620.2	4041.6 kW (11.6 %)
4.5	6838.1	7482.0 kW (9.42 %)

Table 6 Comparison of hydropower generation capacity of three down scale models

Water speed (m/s)	No bottom fin (W)	With bottom fins	Optimized model
1.8	1.42	3.89 W (174.0 %)	4.66 W (228.2 %)
2.2	2.74	8.12 W (196.4 %)	9.53 W (247.8 %)
2.7	4.54	14.37 W (216.5 %)	16.51 W (263.7 %)
3.6	8.84	31.24 W (253.4 %)	34.99 W (295.8 %)
4.5	15.55	61.09 W (292.9 %)	67.19 W (332.1 %)

Conclusions

In this study, a hydropower system which employs paddle wheels and bottom fins to capture hydropower out of water flow was developed and optimized. CFD simulations were performed to validate the power generation capacity of the system, and its economical impact was evaluated based on the CFD results. In CFD simulations, effects of water speed, bottom fins, and shape of paddles and bottom fins on the system power generation capacity were illustrated. Contribution of each pair of paddle wheels in the hydropower generation was analyzed. The CFD simulation results and economic analysis data showed that, averagely,

the presented hydropower equipment can generate and provide electricity for 1645 households at \$0.06/kWh during the first four and half years (payback period) and \$0.02/kWh after that period. Part of the present CFD simulation results had been verified through analytical approach [1, 2], and in order to further verify the applied computational approach and confirm the economical potential and commercialization prospect of the developed hydropower technique, an experimental analysis is required. To prepare for the future experimental validation, a

Table 7 Electric generation capacity of the facility and its economic and social impact

Water speed (m/s)	Electricity (kWh)	Annual income (\$0.06/kWh)	Renewable energy credit \$11/1000 kWh	Total annual income	# influenced households
1.8	6,797,710	\$407,862	\$74,767	\$482,629	443
2.7	11,746,443	\$704,786	\$129,206	\$833,992	767
3.6	27,483,420	\$1,670,605	\$306,273	\$1,976,878	1794
4.5	54,381,679	\$3,262,900	\$598,191	\$3,861,091	3551
3.2 (avg)	25,192,313	\$1,511,538	\$277,112	\$1,788,650	1645

1:30 down scale CFD model was created and used for simulations. The results correlated very well with the CFD results obtained from the full-size model and will be compared with the experimental data in next phase.

Open Access This article is distributed under the terms of the Creative Commons Attribution 4.0 International License (<http://creativecommons.org/licenses/by/4.0/>), which permits unrestricted use, distribution, and reproduction in any medium, provided you give appropriate credit to the original author(s) and the source, provide a link to the Creative Commons license, and indicate if changes were made.

References

- Peymani, Y.F., Liu, Y.-C.: Development and computational verification of an analytical model to evaluate performance of paddle wheel in generating electricity from moving fluid. *Distrib. Gener. Altern. Energy J.* **30**, 58–80 (2015)
- Peymani, Y.F., Liu, Y.-C.: Development of an analytical model to predict the performance of paddle wheel in generating electricity and its validation using computational fluid dynamics (CFD). In: *IEEE Green Technologies Conference*, Tulsa, OK, 19–20 April 2012
- Derradji-Aouat, A., Lau, M.: Ice loads on electric power generating stations to harness ocean energy in the Belle Isle Strait. In: *Proceedings of 18th International Conference on Port and Ocean Engineering under Arctic Conditions*, Potsdam, New York (2004)
- Charlier, R.H.: Forty candles for the Rance River TPP tides provide renewable and sustainable power generation. *Renew. Sustain. Energy Rev.* **11**(9), 2032–3057 (2007)
- Brune, D.E., Lundquist, T.J., Benemann, J.R.: Microalgal biomass for greenhouse gas reductions: potential for replacement of fossil fuels and animal feeds. *J. Environ. Eng.* **135**(11), 1136–1144 (2009)
- Rogers, E.R.: Water wheel electric generation device. US4268757 A, 19 May 1981
- Winius, H.C.: Paddle wheel electric generator. US7969034 B2, 28 June 2011
- Zimmermann, S., Taghipour, F.: CFD modeling of the hydrodynamics and reaction kinetics of FCC fluidized-bed reactors. *Ind. Eng. Chem. Res.* **44**(26), 9818–9827 (2005)
- Petre, C.F., Larachi, F., Iliuta, I., Grandjean, B.P.A.: Pressure drop through structured packings: breakdown into the contributing mechanisms by CFD modeling. *Chem. Eng. Sci.* **58**(1), 163–177 (2003)
- Kerdouss, F., Bannari, A., Proulx, P.: CFD modeling of gas dispersion and bubble size in a double turbine stirred tank. *Chem. Eng. Sci.* **61**(10), 3313–3322 (2006)
- Andersson, A.G., Andreasson, P., Lundstrom, T.S.: CFD-modeling and validation of free surface flow during spilling of reservoir in down-scale model. *Eng Appl Comput Fluid Mech* **7**(1), 159–167 (2013)
- Peterson, E.L., Harris, J.A., Wadhwa, L.C.: CFD modeling pond dynamic processes. *Agric Eng* **23**(1–3), 61–93 (2000)
- Kang, Y.H., Lee, M.O., Choi, S.D., Sin, Y.-S.: 2-D hydrodynamic model simulating paddlewheel-driven circulation in rectangular shrimp culture ponds. *Aquaculture* **231**(1–4), 163–179 (2004)
- Liu, Y.-C., Peymani, Y.F.: Evaluation of paddle wheels in generating hydroelectric power. In: *ASME 2012 International Mechanical Engineering Congress and Exposition, IMECE2012-85121*, pp. 675–684, Houston, TX, 9–15 Nov 2012
- Tu, J.-Y., Yeoh, G.-H., Liu, C.-Q.: *Computational Fluid Dynamics: A Practical Approach*. Butterworth-Heinemann, Oxford (2008)
- Bansal, R.K.: *A Textbook of Fluid Mechanics and Hydraulic Machines*. LAXMI Publications, Ltd., New Delhi (2005)
- Lorenzini, G., Moretti, S.: A CFD application to optimize T-shaped fins: comparisons to the constructal theory's results. *ASME J. Electron. Packag.* **129**(3), 324–327 (2007)
- Lorenzini, G., Moretti, S.: Numerical performance analysis of constructal I and Y finned heat exchanging modules. *ASME J. Electron. Packag.* **131**(3), 031012-1–031012-10 (2009)
- Lorenzini, G., Moretti, S.: A Bejan's constructal theory approach to the overall optimization of heat exchanging finned modules with air in forced convection and laminar flow condition. *ASME J. Heat Transf.* **131**(8), 081801-1–081801-18 (2009)
- Lorenzini, G., Moretti, S.: Bejan's constructal theory analysis of gas-liquid cooled finned modules. *ASME J. Heat Transf.* **133**(7), 071801-1–071801-10 (2011)

