

DOCUMENT RESUME

ED 131 817

HE 008 450

AUTHOR Corson, John J.; And Others  
 TITLE Changing Patterns of Governance in Higher Education.  
 Report Series 1975-76, No. 2.  
 INSTITUTION Arizona Univ., Tucson. Coll. of Education.  
 PUB DATE Jul 76  
 NOTE 72p.  
 AVAILABLE FROM Committee on Higher Education, University of Arizona,  
 1415 North Fremont Avenue, Tucson, Arizona 85719

EDRS PRICE MF-\$0.83 HC-\$3.50 Plus Postage.  
 DESCRIPTORS Coordination; \*Educational Administration; \*Federal  
 State Relationship; \*Governance; \*Government Role;  
 \*Higher Education; Post Secondary Education;  
 Vocational Education

IDENTIFIERS \*Autonomy; \*Government School Relationship

ABSTRACT

Patterns of governance in higher education have changed dramatically during the past quarter century and the trend will probably continue. Since the essential parts of institutional autonomy continue to be debated and vary from state to state, the following discussions were sponsored by the University of Arizona. The topics covered include: "Changes in the Governance of Institutions of Postsecondary Education," by John J. Corson; "The States and Governance in Higher Education," by John D. Millett; "Keeping in Touch, the Campus-Capitol Interface," by Marvin D. Johnson; "Federal Effects on State and Institutional Policies," by Allan W. Ostar; and "Coordination of Program Developments in Postsecondary Vocational Education," by T. Harry McKinney. (LBH)

\*\*\*\*\*  
 \* Documents acquired by ERIC include many informal unpublished \*  
 \* materials not available from other sources. ERIC makes every effort \*  
 \* to obtain the best copy available. Nevertheless, items of marginal \*  
 \* reproducibility are often encountered and this affects the quality \*  
 \* of the microfiche and hardcopy reproductions ERIC makes available \*  
 \* via the ERIC Document Reproduction Service (EDRS). EDRS is not \*  
 \* responsible for the quality of the original document. Reproductions \*  
 \* supplied by EDRS are the best that can be made from the original. \*  
 \*\*\*\*\*

ED131817

# CHANGING PATTERNS of GOVERNANCE IN HIGHER EDUCATION

U.S. DEPARTMENT OF HEALTH,  
EDUCATION & WELFARE™  
NATIONAL INSTITUTE OF  
EDUCATION

THIS DOCUMENT HAS BEEN REPRODUCED EXACTLY AS RECEIVED FROM THE PERSON OR ORGANIZATION ORIGINATING IT. POINTS OF VIEW OR OPINIONS STATED DO NOT NECESSARILY REPRESENT OFFICIAL NATIONAL INSTITUTE OF EDUCATION POSITION OR POLICY.



## *Contributors:*

**John J. Corson**

**Marvin D. Johnson**

**T. Harry McKinney**

**John D. Millett**

**Allan W. Ostar**

A publication of the Higher Education Program  
College of Education  
University of Arizona

The Higher Education Program at the University of Arizona was established first in the early 1960's and reorganized in 1974 to expand as an area of scholarly inquiry, research, instruction and public service. The Program conducts studies, projects, conferences, and forums and makes the results available to other institutions and persons with mutual concerns. Graduate degree programs are designed to prepare two types of administrators: generalists who coordinate policy development and decision making and specialists who facilitate the flow of technical information and provide expertise in a special area. Research programs are conducted in critical areas of public policy concern whether it be state or regional, national or international in scope. Similarly, public service projects are conducted in major fields of policy study and development. The long-run goals of the Higher Education Program are to contribute to the continuing change and improvement in the administration of Higher Education through the education of its graduates and the improvement of public policy through its research studies and public service projects.

The Program's publications are designed to be relevant to the needs of the University, to the State of Arizona, and to colleges and universities throughout the country. They can be obtained on a limited basis by institutions and associations which are able to exchange publications of a comparable type. Others may obtain copies at a reasonable price which is designed solely to pay the cost of publication. Inquiries should be addressed to Chairman, Committee on Higher Education, University of Arizona, 1415 North Fremont Ave., Tucson, Arizona 85719.

Report Series 1975-76, No. 2

**CHANGING PATTERNS  
of  
GOVERNANCE IN HIGHER EDUCATION**

*Contributors*

John J. Corson  
Marvin D. Johnson  
T. Harry McKinney  
John D. Millett  
Allan W. Ostar

Higher Education Program  
College of Education  
University of Arizona

July, 1976

## FOREWORD

Patterns of governance in higher education have changed dramatically during the past quarter century and there is every prospect that this trend will continue. The Federal government historically has been a government of "limited powers" and the state governments were established as governments of "general powers," with the responsibility for education. As the Federal support for higher education increases, the control of the purse strings and the conditions required for the use of Federal funds have direct impact on the patterns of governance in the states.

Likewise, as the institutions of higher education spend a larger and larger proportion of the state budgets there is increasing involvement between agencies of state government and higher educational institutions. New regulatory agencies have developed with coordinative powers, or new governing boards or agencies have been established with tight controls over budgets, programs and facilities of varied clusters of institutions in different states. New patterns of policy development and operational controls have been established. Major efforts have been made very recently to define "levels of decision making" and "levels of authority" — as the various agencies, offices and boards struggle to determine their powers and the best methods to secure the optimum program of higher education for the investment that is made.

The essential parts of institutional autonomy are being debated widely and they now vary a great deal from state to state. The democratic way to determine such important policy decisions requires that all interested parties be heard and that the institutions involved be participants in the debates. Thus, the Higher Education Program of the College of Education, University of Arizona, sponsored the discussions for which these papers were prepared. Developed by persons with considerable expertise in these problems, they add valuable insights to the ongoing debates on these topics. This publication is designed to make their cogent ideas on the issues available to a wider audience.

Fred F. Harclerod  
Chairman, Committee on Higher Education  
University of Arizona

## *Conference Participants*

**Norbert Bruemmer**  
Executive Dean  
Maricopa Technical College

**John J. Corson**  
Visiting Professor of Higher  
Education and Public Administration  
University of Arizona

**Eugene L. Dorr**  
Associate Superintendent for  
Career & Vocational Education,  
Arizona

**Marvin D. Johnson**  
Vice President for  
University Relations  
University of Arizona

**Richard A. Harvill**  
President Emeritus  
University of Arizona

**Robert Johnson**  
Vice President  
University and Student Relations  
University of California

**A.L. Knoblauch, Regent**  
Regency Universities of Illinois  
Member, Illinois Board of  
Higher Education

**T. Harry McKinney**  
Professor of Higher Education  
Michigan State University

**John D. Millett**  
Senior Vice Pres. & Director  
Management Division  
Academy for Educational  
Development, Wash., D.C.

**C. Theodore Molen**  
Vice President  
American College Testing Program

**Allan W. Ostar**  
Executive Director  
American Association of  
State Colleges and Universities

**John Prince**  
President  
Maricopa County Community  
College District

**Lawrence Woodall**  
Executive Coordinator  
Arizona Board of Regents

## TABLE OF CONTENTS

Foreword	iii
1. Changes in the Governance of Institutions of Postsecondary Education John J. Corson	1
2. The States and Governance in Higher Education John D. Millett	8
3. Keeping in Touch, The Campus — Capitol Interface Marvin D. Johnson	18
4. Federal Effects on State and Institutional Policies Allan W. Ostar	26
5. Coordination of Program Developments in Postsecondary Vocational Education T. Harry McKinney	33

## CHANGES IN THE GOVERNANCE OF INSTITUTIONS OF POSTSECONDARY EDUCATION

John J. Corson

A quarter of a century ago when I was learning the arts of a management consultant, our managing partner bought, and hung in the room in which our partners met, an abstract oil painting entitled *Forces at Work*. I recall it as an unintelligible assortment of shades of blue. His purpose was not to further the art appreciation of his colleagues but to emphasize our obligation, in studying the organizational and management problems of corporate clients, to look beyond conventional measures of sales volume, net profit, operating ratios and return on investment to the "forces at work" in and around the industry in which the client company operated and to which its organization and processes had to adapt.

Similarly, if we would understand the changes that have taken place in the governance of our colleges and universities, we must, I believe, recognize the experiences that these institutions have shared (or suffered, choose your own verb) over the past quarter of a century. In these experiences, we will find the roots of changes in institutional governance. And we will be made to recognize that the forces at work are forces that are forcing change in many other social institutions — the corporation, the hospital and governmental agencies, for example — as well as in the college and university.

Consider with me five forces that have wrought change in the institutions of this country over the past quarter of a century.

The first is demographic — the growth and the substantial redistribution of this country's population. Over this quarter of a century the numbers enrolled in undergraduate institutions increased fourfold. The number of men and women enrolled in graduate and professional schools increased fivefold, and the number enrolled in the community colleges increased still more. Simultaneously the growth in urban centres has given rise to what others have branded the "sidewalk university" and has diminished or made obsolete residential education on many, many campuses.

The second force at work is the increasing pace at which new knowledge has been accumulated. This force poses what were unprecedented problems of codification and transmittal. Faculties had to be expanded, and were more and more specialized. Courses proliferated. Departments were subdivided, and new schools were established. Costs increased.

The third force at work was an expanding demand for the fulfillment of the democratic ideal. The abandonment in higher education of a philosophy of elitism, the substitution of the idea that all young people, regardless of social or economic status, should have the opportunity to continue on beyond the high school was simply the acceptance of a philosophy as to the responsibility of the society that was being accepted generally.



This philosophy holds that all individuals shall be assured of a minimum of well-being. This philosophy is reflected in the provision of an expanding array of health services for all, in the provision of publicly subsidized housing through various mechanisms, in the burgeoning growth of the Food Stamp Program, and it is reflected in the development of Federal and state programs of financial aid for students in higher education.

The fourth force at work was the expansion of government, particularly the expansion of social programs. Our colleges and universities saw, benefitted from, and induced a major extension of the responsibility of government for the support and, perhaps unwittingly, the direction of postsecondary education. First the state governments and subsequently the Federal government have invaded aspects of institutional operations once inviolate. Both state and Federal governments have created new institutions that claim a steadily increasing role in governance.

A fifth force at work may be described as the "uprising of the underdog." Looked at from the vantage point of 1978, the uprising of the students in the 60s, traumatic as it seemed then, was of only passing consequence.

Certainly it was not a phenomenon of equal consequence to the organization of workers in the 30s, or of the blacks since 1954, and of women in still more recent years. In each instance, the "underdog" insisted upon a larger voice in the making of decisions that affected him (or her), and they forced traumatic change in the functioning of institutions.

How much the coping with these five forces at work throughout our society has changed the patterns of governance in our colleges and universities cannot be measured with neat precision. Yet it is clear that the impact of these forces has been substantial. Oliver Wendell Holmes once said that "a mind once stretched to encompass a new idea can never return to its former dimensions." Analogously, it is clear that after coping with these forces our colleges and universities can never again utilize the simple forms of governance that had prevailed.

#### Lacking A Base Line

Alice, you will recall, in the course of her travels through Wonderland, commented that when she used a word it meant just exactly what she intended it to mean. By the term "governance" I mean (and others may attach different meanings to it) the processes by which decisions are made, who participates in these processes, the structure that relates those individuals, the effort that is made to see to it that decisions once made are carried out, and the processes used to evaluate the results that are achieved.

To assert that the forces I have enumerated have changed the governance of educational institutions, as I have now defined "governance," is to imply an understanding of what institutions and their functioning were like in 1950. In truth, it is difficult to distinguish what *was* from our romantic notions of the "good old days" in higher education. Moreover, it is impossible to generalize: the calibre, the character and the governance of institutions varied greatly from institution to institution.

The literature of higher education that existed by 1950 included a number of histories of individual institutions (e.g., Philip Alexander Bruce's *History of the*

*University of Virginia*), a number of biographies of presidents (e.g., Goodspeed's life of William Rainey Harper and Mim's life of Kirkland of Vanderbilt), some works analyzing the roles of participants, particularly the faculty, and one work (Lloyd S. Woodburne's, *Principles of College and University Administration*) that attempted (and to my way of thinking did not succeed) in rationalizing the governance of colleges and universities.

The literature existent in 1950 offers many hints but no wholesided description or appraisal of the nature of governance. Hence, in assessing change, we have no solid, cross-the-board benchmarks to look back to, only scraps of understanding and nostalgic notions. But what evidence there is suggests that the governance of institutions of postsecondary education has been changed in at least four basic respects:

The individual institution is now part of a system; it is no longer a free-standing, autonomous institution.

Decisions within the individual institution are subject to review, and even to prescription, by governmental agencies to a degree unforeseen (and unacceptable) in 1950.

Collegiality in the making of the most fundamental decisions of the individual institutions has been diminished, altered and, in some instances, abandoned.

The leadership of the individual institution has been delimited in scope and diminished in power and prestige.

#### - Changing Structure

Consider first the changes wrought in the structure of the higher education industry. I refer to:

- 1 — the emergence of public institutions and the decline of private institutions,
- 2 — the establishment and substantial growth of community colleges, and
- 3 — the subordination of colleges and universities within systems composed of a few or many institutions.

Let me remind you of the magnitude of each of these three changes. Within the quarter of a century just past:

- the proportion of postsecondary students enrolled in public institutions has steadily grown and now includes 75 per cent of all enrollees;
- the proportion of postsecondary students enrolled in the two-year institutions has grown rapidly and now approximates 40 per cent of all enrollees, and
- the proportion of all postsecondary students enrolled on campuses which are parts of linked systems has grown materially.

The significance that you or I attach to these trends is related to our respective concepts of what is "good" higher education. If we attach large value to that education in which the imagination and creativity of the individual teacher is

utilized to the fullest, in which curricula are designed and flexibly changed from time to time by faculties, in which leadership in developing academic programs and improving teaching processes is supplied by teachers, department heads and deans who are living and growing with students, then we will tend to rebel against aspects of centralized governance that accompany the structural changes I have identified.

On the other hand, if we assume that much of the task of post secondary education is the transmission of knowledge that has been codified over the decades and the prime consideration is the economy with which that transmission is achieved, then we will approve the evolution of what I will describe as "patterned education." By "patterned education" I mean that education in which programs (and sometimes courses) must conform with the specifications of a state agency or the dictates of a professional accrediting agency, and in which courses are taught in accordance with guidelines formulated by the staff of a state agency.

Whatever our philosophy of education may be, we must recognize that the changes in the *structure* of postsecondary education have tended to centralize responsibility for decisions as to who shall be admitted, what shall be taught, and to a lesser degree as to who shall teach. These changes in structure tend to substitute "system wide," "statewide" or even Federal decisions, for decisions formulated within the individual institution. These changes in structure have reduced autonomy, the diversity among institutions, and tended to homogenize institutions.

Likely there is no denying that these changes in structure have made mass education more economical and, in a narrow sense, more efficient. Certainly there is no denying that these structural changes shift responsibility for decision making substantially.

#### **Prescriptive Decision Making**

Much that has been said about the impact of structural changes on governance apply particularly to public institutions. But the forces that have induced change in governance — especially the expansion of government and the "uprising of the underdog" — have wrought other and substantial impacts on the governance of *private*, as well as public colleges and universities.

The impact on institutional governance of Federal efforts to bring about *equality of opportunities* for minorities, both as students and as faculty members, is obvious. It is reflected in the daily papers, in a succession of court decisions and in a large and growing body of rules and regulations with which institutions must comply. The content of these rules and regulations is a part of the lore that must be acquired by departmental chairpersons, deans, deans of students, financial aid officers, comptrollers, presidents and others.

To picture the impact in these terms is neither to berate this development nor to complain. The objective is laudable. Yet, if we would assess changes in governance surely we must recognize the abridgment of the freedom of institutional officers and faculties to make decisions as to admissions, and as to faculty selection that flow from Federal efforts in these areas.

Similarly, we must recognize the impact on the governance of universities of the ebb and flow of *Federal funds for the support of research*. It is logical that the Federal government (impelled by the urgency of war) should have drawn on the

specialized talent in university faculties. Manifold benefits accrued to the institutions — expanded faculties, unprecedented physical facilities, and the development of graduate education — as a consequence of the great expansion of Federal grant monies from 1950 to the late 1960s.

The reduction of Federal support during more recent years has illuminated the dependence of graduate education, even in some of our most prestigious universities, on this Federal patronage.

The growth of Federal grants during the 50s and 60s had tended:

- 1 — to make entrepreneurs of some faculty members and to make them relatively independent of either the department or the institution with which they were affiliated,
- 2 — to encourage the mobility of faculty members from institution to institution, and
- 3 — to create imbalances between the generously endowed hard sciences and the neglected humanities.

The subsequent retrenchment of Federal support forced traumatic curtailment in research and in graduate education — and made manifest the extent to which decision making as to research and graduate education is prescribed by Federal funding decisions.

A third impact of Federal actions on governance is seen in its *support of institutions*. This Federal effort was relatively late coming. Much of the support that is provided to maintain the viability of institutions is attached to the provisions for the support of students or research. As the need for institutional support became recognized new rules and regulations were promulgated specifying the terms under which institutional support would be made available. It is not surprising that many institutions, particularly among the poverty stricken developing institutions, have been overly ready to comply, unquestioningly.

#### Abandonment of Collegiality

The collegial making of decisions as to which students shall be admitted, what shall be taught, and who shall teach has long been regarded as a cardinal element of academic governance. Likely collegial decision making by the whole faculty, as distinguished from departmental decision making, was an ideal more claimed than real. Whatever was the case, collegial decision making obtains less often today than in the past.

The decline of collegiality must be attributed, as I see it, to four factors.

First, the size of institutions. The building of consensus among a faculty of 25 or 75 members is more feasible than among members of a faculty including 500 or 2,500 members. In the large urban university where faculty members of a single department teach at various times of day and live in homes widely scattered over a metropolis, they may seldom come in contact with one another, and the department head despairs at building a binding collegial spirit.

The second factor undermining collegiality is specialization. The diverging interests of narrowly oriented specialists tend to make collegial association of

less concern to many-faculty members. They have little in common even with members of what once was regarded as a single discipline.

A third factor undermining collegiality has been the increasing centralization of authority. When decisions once entrusted to faculties — for example as to the introduction of courses, and in a few places the promotion of faculty members in some situations — are to be made by a remote, anonymous authority, guided by other values, faculty members have tended to regard as futile the effort to meet and formulate their own decisions.

Finally, the development of faculty unions is a fourth factor limiting collegiality. College and university administrators, confronted with the necessity of writing labor-management contracts, and often counseled by lawyers experienced in industrial labor relations and equally inexperienced in the character of an academic institution, have tended to reconcentrate decision-making authority that had been exercised by the faculty.

### Undermining Leadership

Leadership in the American society and in its organizations, has been under attack. Lyndon Johnson, recognizing this fact, commented that "once a man puts his head above the grass, Americans gleefully combine to cut him down to size." The "underdogs" — youth, blacks, women, the poor, even the lower ranking priests in the Catholic hierarchy — in their struggle for enhanced status, have limited the authority of those in leadership positions in academia, and as well in industry, government and the church. Specialists have increasingly challenged the ability of generalists to make decisions. And persisting pressures toward centralization have diminished the authority of those who formerly led subordinate units — in industry, in government and in academia.

In the college and in the university these forces have made articulate mouses of trustees and presidents at the time when critical problems — financial, managerial and, I emphasize, educational problems — pose an especial need for leadership. The departmental chairpersons, deans and provosts have lost power to the students, sometimes to the faculties and in some instances to unions, and more to the governmental agencies. The presidents' and trustees' power has been diminished, in principal part, by the intervention of state and Federal agencies.

Moreover, the forces at work have altered the nature of leadership in the college and university. Harold Dodds, then recently retired as president of Princeton, argued in 1962 that the president should be an "educational leader" not a "caretaker," and he contended that a president should devote as much as half his time to education. This contention seems very unreal when one looks, in 1976, at the activities of presidents, let us say in a major state university, a large community college, or even a small private women's college, teetering (as many are) on the financial brink.

There are current educational problems to resolve — the plight of the liberal arts at a time when career oriented education is the vogue, the pressure for condensing the time claimed for the baccalaureate degree, the formation of programs for an increasing body of adult learners, and the development of aging faculties in a time of static growth — but presidents, consumed with managerial, financial and political problems, can or do exercise little leadership in resolving such problems. It is chance, not a well designed system of governance, that is

relied upon to provide the leadership required for what one writer has recently branded the "organizational anarchy."

### Goals of Governance

I am mindful of Alexander Pope's suggestion that "as to forms of government let fools contest." The form of governance wrought by the forces at work in our society during the past quarter of a century is not to be judged by standards romanticized as having existed in an earlier day, nor by standards of efficiency and economy presumed to exist in other institutions conducting large scale operations.

Many Americans will attend these institutions during the remaining quarter of this century. Will the processes of governance that obtain provide a climate that stimulates the intellectual curiosity of these prospective attendees, or makes of them time-serving memorizers? Will these processes of governance prod faculty members to grow and to strive to excite their students or simply to meet their classes and to fulfill contractual obligations?

Idealistic, impractical concepts, you may think. But if postsecondary education is to contribute to the self-fulfillment of individuals and to equip members of a democracy to play their parts as citizens, the product expected of this country's institutions of postsecondary education is inquiring minds, not merely large numbers of men and women who have met the requirements for degrees.

How to maintain institutions capable of turning out this product, when millions are to be educated each year with limited resources, is the problem of governance facing postsecondary education. The tendencies toward centralization routinization and homogenization seen in the changes in governance that have taken place offer, it seems to me, little assurance that our institutions of postsecondary education will generally meet the idealistic and impractical goal that I have pictured.

## THE STATES AND GOVERNANCE IN HIGHER EDUCATION

John D. Millett

It is fair to say that, to the extent higher education in the United States is a planned endeavor the planning is being performed primarily by the 50 state governments comprising our federal republic. Certainly there is no comprehensive planning for higher education being undertaken by the federal government in Washington, and I make this observation with a sense of thanksgiving rather than as a voice of criticism. There is a great deal of planning going on within particular colleges and universities and within multi-campus systems of higher education. Yet the indispensable, general interest in higher education is a state government interest.

By no means do I wish my remarks here to be construed as any lack of appreciation for the major role of the federal government today in the planning for and support of research within our major universities. Furthermore, the federal government role in the financing of students has become one of major proportions, involving as it does today some six billion dollars in aid to students. In fact, I think we may say that the federal government's interest in higher education primarily centers in the financing of research and in the financing of students. There are certain other categorical concerns, as with education in the health professions and with education in a few other professions. These categorical interests, however, remain fairly modest in scope.

Our state governments are critical to the well-being of higher education for two very good reasons. It is our state governments that have established public institutions of higher education and that have chartered private institutions of higher education. Secondly, it is our state governments that finance our public institutions of higher education, and now in a very substantial way are helping to finance private higher education. To the extent that there are policy objectives to be achieved in higher education in this country, these policy objectives originate in major part with our 50 state governments.

I would like to insert here parenthetically some observations about state governments and research universities. I have suggested that the federal government is the primary source of funding for university research, but I also want to assert that state governments are largely the instrumentality by which public research universities are created and maintained. Three years ago I identified 59 universities in the United States that I classified as leading research universities and another 39 universities that I classified as other research universities. Of the 59 leading research universities, 36 were state universities. Of the 39 other research universities, 26 were state universities. The circumstances and general support that make it possible for a state university to obtain recognition as a leading research university or as a research university are

provided by our state governments. Our state governments made research universities possible; our federal government provides the funding for research projects that largely maintain research scholarship in these research universities.

The subject for our consideration today is that of the states and the governance of higher education. Obviously we must begin with some common understanding of the phenomenon we are discussing. Some 15 years ago John J. Corson in his book on the governance of colleges and universities defined governance as decision making, as enacting the rules that govern endeavor and behavior. Most of us who have written and spoken about the governance of higher education in the intervening years — and we are a fairly numerous company — have accepted this definition. We think of governance as decision making.

In a recent book of my own I have been somewhat critical of this use of the word governance as too narrow or too restricted in scope. I have no objection to the definition of governance as a structure and process of decision making so long as we understand that universities and governments involve a good deal more than governance. As I have studied the governance discussions within and about colleges and universities, I have become aware of two major deficiencies. The concern about governance on many campuses was primarily a concern about representation in the decision-making structure and process; it was a demand essentially for some means whereby faculty members and students were assured of a voice in the enactment of campus rules. I have found myself entirely in sympathy with this demand, even if I have not always been in sympathy with the way in which the demand was presented or with a particular proposal for implementation.

Where the discussions on governance generally revealed their weaknesses was in their absence of concern about a structure of effective leadership and about a structure of work performance. There were also some weaknesses of purpose and of process in these discussions about governance. The deficiencies that have bothered me the most, however, as I have reviewed campus experiences of the past ten years, have been these deficiencies of leadership and of management. Somehow it was assumed that proper representation of various constituencies of interests within the academic community would automatically produce good decision making, or any kind of decision making. The need for leadership in decision making was supposed to take care of itself. And somehow it was assumed that proper representation in a decision making process would automatically result in performance of the desired work activity and the desired social behavior.

For the moment, nonetheless, let us think of governance as a structure and process of decision making. Our interest in governance then is in that decision making which affects higher education. When we add a further element to the definition, the element of state government, then we have the major ingredients for this current discussion. Let me make clear the focus of my interest. I want to call attention to the structure and process for decision making *within* our state governments affecting higher education. I do not wish to include in this discussion any extensive concern with governance of a college or university campus. I do want to emphasize higher education governance as it involves state government itself.

I have already asserted my conviction that our state governments are the critical actors today in determining the future and fate of higher education in this



country. If you accept this proposition, then the structure and process of decision making within state government as it involves state purpose, state policies, state programs, and state financing are absolutely critical to the well-being of higher education. And let us not forget that one-third of all educational and general income for higher education, the largest single source of financial support, comes from the appropriations of state governments.

Thanks to the efforts of Kent Halstead of the Office of Education in the United States Government we have today a substantial compendium of the issues that state government planning and decision making must address. In a volume of over 700 pages Halstead discusses state structure for higher education planning, access to higher education, financial aid to students, the role and mission of different kinds of public colleges and universities, the search for institutional excellence in such matters as enrollment size and faculty quality, the geographical distribution of higher education institutions, the relationship of higher education programs to manpower supply and demand, library resources, space management and space requirements, campus and building planning, institutional financing, and state government budgeting for current operations and capital improvements. As an agenda for state government decision making about higher education, the Halstead volume is more than an adequate guide. Indeed, I can say that in my own experience in state government the Halstead agenda is in fact the agenda of a state government planning agency for higher education.

There is one qualification I would add to the state government agenda as presented by Halstead. State governments must also decide the desirable relationship between the public sector of higher education and the independent sector of higher education within a state. State governments have enabled independent colleges and universities to be chartered as non-profit, public service enterprises. State governments have usually extended the privilege of tax exemption to these colleges and universities insofar as the general property tax upon their plant used for educational purposes is concerned. Independent colleges and universities are generally exempted from state income taxation and often from state government sales taxes. In recent years, many state governments have extended student aid programs to students in the independent sector, and in a few instances state governments have even provided direct institutional financial support to independent colleges and universities. Moreover, the location of public colleges and universities and the scope of the instructional programs allocated to public colleges and universities may well have a direct impact upon the operation of independent colleges and universities.

It is not my intention here to embark upon a discussion of the substantive issues on the state government agenda for higher education. Halstead has written a large book on these issues, and I have written a smaller book. The issues are real, vital, and complex. They are not easily resolved and they are never resolved for all time. Planning and decision making involve continuous activity.

The issue I do want to address here is the issue of structure for state government planning and decision making about higher education. I presume I do not need to belabor here a distinction between planning and decision making. Planning precedes decision making, and starts again after decisions are made in terms of evaluating the consequences of past decisions and preparing for new decisions. Nor do I need here to involve us in a discussion of the decision-making structure of legislative, executive, and judicial power in state government. I do want to raise some questions about the structure for state government planning as a part

of this decision-making process, as a part of the governance of higher education by state government.

For a great many years most state governments perceived no particular need to create a state government administrative agency to formulate and articulate the state government interest in higher education. Most state governments sometime before 1900 established either a state board of education or the position of state superintendent of public instruction as the administrative mechanism for developing the state interest in public elementary-secondary education. Apparently no need was perceived for any similar arrangement in higher education. Obviously in those days public higher education must have been only a minor claimant upon the financial resources of state government.

When the executive budget movement materialized in state government around 1910 and thereafter, state college and state university officers began to meet with state budget officers to review the financial requirements of public higher education. In some states more than in others, strong executive budget offices began to emerge, and a few of these came to be influential in the development of state government policy affecting higher education. Some of these executive budget offices, and now legislative budget offices, are the focal point for much of the state planning today that precedes state decision making about higher education.

As the executive budget process developed in state government, some kind of higher education mechanism at the level of state government itself became increasingly desirable. In some states the response of public higher education institutions was the organization of a council of presidents who undertook on a voluntary basis to plan, coordinate, and budget for public higher education. In some states this voluntary administrative arrangement became quite effective. Its basic weakness was simply that voluntary planning and budgeting depended upon the good-will and support of all participants; if disagreements and rivalries appeared, the voluntary effort disintegrated. Furthermore, executives and legislators sometimes came to perceive voluntary planning as a protection of vested interests rather than the articulation of a state government interest. I know whereof I speak, because I was a participant in both kinds of events in one state.

In other states, especially during the Depression years of the 1930's, state boards of higher education were established as administrative agencies of state government for higher education. In some other states where as early as 1900 competition between state universities, state colleges of agriculture and mechanical arts, and state teachers colleges was observed, state legislatures or state constitutions provided for one single state-wide governing board for all of public higher education. Something of this early history was reviewed in a book about public higher education written by Lyman Glenny and published in 1959.

Today I am primarily concerned about two quite different administrative arrangements for undertaking the planning for the state government interest in higher education. I have concerns about each of the administrative arrangements that now occur within the state governments, although my concerns are different according to the particular arrangement. As of 1975 I count 21 states that have established a state-wide governing board for public institutions of higher education. I count 26 states with a state planning board for higher education.

There are three states, small states, that appear to have neither administrative arrangement.

Let me summarize my concerns about the state planning board under three headings: a concern about the appropriate organizational arrangement linking the state board of higher education to the executive and legislative branches of state government; a concern about the adequacy of administrative authority vested in the state board; and a concern about the relationship of state boards both to state colleges and universities and to independent colleges and universities. I shall elaborate somewhat upon each of these concerns in a moment.

Let me summarize my concerns about the state-wide governing board under three headings: a concern about the adequacy of lay governing influence upon the affairs of individual campuses; a concern about the capacity of a state-wide governing board objectively to articulate a state government interest in higher education; and a concern about the growth of a state higher education bureaucracy controlling institutional affairs. I shall comment about these concerns in a moment.

I see no reason here to defend the proposition that a state government administrative agency in the field of higher education is an essential element of state government. This proposition has been much debated over the past 25 years, but it appears that the argument is now mostly a matter of history. There are still bitter controversies about the kind of state administrative machinery appropriate for higher education and the scope of its authority, but the utility of some kind of machinery is now generally acknowledged. Indeed, the Education Amendments of 1972 as enacted by the Federal Congress in Section 1202 endorsed the need for a state government administrative agency "broadly and equitably representative of the general and public and private nonprofit and proprietary institutions of postsecondary education in the state...." Essentially the argument today is not whether or not to have a state government administrative agency for higher education but what kind.

Let us begin with my concerns about the state planning board in higher education. I have vivid recollections of a time when this very word planning was one arousing suspicion and fear about governmental intentions. Now planning as an essential administrative and governmental procedure is widely accepted. But we remain confused about the relationship of planning to politics, about the relationship of administration to governmental decision making. Higher education planning is first of all a professional task. Enrollment trends, student access, manpower supply and demand, desirable instructional programs, the scope of other educational programs, the geographical distribution of programs and facilities, the quality of educational programs, the financing of institutional costs, the financing of student access, the inter-relationship of the public and private sectors of higher education — these are all issues that require careful, professional study. All of these problems are complex, and reasonable people have different conclusions of fact and different opinions about the values involved. The analysis of higher education issues is a task for knowledgeable, competent persons. The resolution of the issues is a task for political judgment expressed by elected representatives of the people.

It is arrant nonsense to think that issues about education can be separated from the political process. In an earlier, less burdensome society, there were educational enthusiasts who thought it possible to separate education from

politics. Surely no one is left today with any such naive point of view. Yet we establish state boards of higher education with lay members appointed for lengthy and overlapping terms of office, and ask these lay members to select a professional administrative officer. Then we expect this professional administrative officer to develop effective and influential relationships with the state chief executive and legislature. This arrangement is an administrative prescription for political ineffectiveness or for professional instability.

One or two states have recognized the dilemma and have chosen the route of an executive department of education headed by a secretary or director of education. The department head is a recognized political selection and colleague of the chief executive. There then remains the matter of organizing a structure for elementary-secondary education and for higher education within this executive department framework. One arrangement is to have a commissioner for basic education and a commissioner for higher education appointed as personal associates of the secretary of education. Another arrangement is to continue state boards of education and state boards of higher education with their separate selection of a professional administrator. The secretary of education is then a kind of political filter through which professional data and advice are transmitted to the chief executive and legislature.

My own judgment is that we have not yet found a satisfactory arrangement for inter-relating professional and political judgments on higher education issues. I suspect that we shall continue to experience tension in the relationship, and that we shall continue to experiment with different relationships, both personal and structural.

My second concern with state boards of higher education is with the scope of their authority. There is a wide range of authority vested in these boards today, from a purely informational role to a coordinating role. My own opinion is that state boards of higher education restricted to an informational role have a very limited utility. This opinion obviously reflects my experience with a coordinating board. I think a state board of higher education should have certain definite authority if its capability for useful action is to be realized. I think a state board of higher education should have authority to approve or disapprove new degree programs proposed by any public institution of higher education. I think a state board of higher education should have authority to approve or disapprove the geographical dispersion of instructional and other programs such as continuing educational programs proposed by any public institution of higher education. I think a state board of higher education should have authority to establish a budget system for public higher education and to recommend state government financial subsidy of each institution for both current operations and capital improvements. I think a state board of higher education should have authority to prepare and adopt a master plan for higher education services in the state. A state board with these kinds of authority is in a position to share a planning role with institutions of higher education, to define the state interest in higher education, and to make recommendations for legislation to a governor and to a general assembly that are meaningful.

A state board of education with purely advisory authority is in a position to collect statistical information and to conduct interesting studies. It is likely that few persons in the executive branch, in the legislative branch, or in institutions of higher education will pay much attention to such a board. These persons will have very little reason to pay any attention to such a state board of higher education.

Such a state board has no power. And in politics — federal, state, or local; economic, religious, educational, or associational — in politics the name of the game is power.

My third concern with a state board of higher education is its relationship to both public and private institutions of higher education. It is essential, I believe, for a state government — and this means first of all for a state board of higher education — to have an interest in and concern for higher education services within the state as a whole. This kind of interest and concern must extend to the scope of needed instructional programs and other activities and to the totality of the institutional organizations both publicly sponsored and privately sponsored available to deliver these services. Today there are those who insist that this interest and concern must embrace proprietary institutions as well as public institutions and private non-profit institutions. Personally, I am somewhat uneasy about just how far a state board should become involved with private enterprise for individual or corporate profit, but certainly there is a role for the proprietary college under proper, regulatory provisions of law.

The privately sponsored college or university not-for-profit has played an important part in American higher education and continues to provide essential services to our nation. Public higher education would suffer in my judgment if there were not the alternative choice and the alternative governance of private higher education. For this reason and in the interest of governmental economy, a state board of higher education needs to have a point of view, indeed a public policy, that encourages the continued services of private higher education.

I do not intend to suggest that a state board of higher education can have a state-wide point of view only if its members come from public, private, and proprietary institutions themselves. Actually, I have some strong doubts about the capacity for decision making in the public interest by boards composed of individuals with a vested interest. It is terribly important that public members of a state board of higher education have access to advisory committees from all kinds of colleges and universities, and provide opportunity for interested parties and individuals to present their point of view. I am disposed to believe that the public interest in higher education is more likely to emerge from a board of public members than from a board of institutional delegates.

Let me turn then to some elaboration of my concerns about the state-wide governing board as the principal state government administrative arrangement for higher education affairs. As I have indicated there are some 21 state governments that have state-wide governing boards. Some of these organizational arrangements are of recent legislative enactment, and I am told that there are debates now going on in several other states about the desirability of establishing state-wide governing boards.

I can understand the executive and legislative fascination with the state-wide governing board. Such a board suggests a state-wide authority to control and prevent competition among various state colleges and universities, to impose common regulations and standards of operation, to achieve an appropriate equality of support for similar instructional programs, to ensure political response to political expectations of the state higher education system. When state governments have had a weak arrangement for state planning and coordination, when state governments continue to encounter jealousies and importunities among state colleges and universities, the device of a state-wide

board with the full authority of governance over all campuses has a certain cosmetic attraction. My own judgment is that this attraction is almost entirely cosmetic.

My first concern with the state-wide governing board is a concern about the dilution of the lay influence in campus governance. A governor and a legislature may perceive a state-wide governing board as responsive to their point of view, but the state-wide governing board then becomes a weak device for influencing faculty, student, and administrative behavior at the level of the individual campus. I am well aware of the current cynicism about the lay influence in campus governance of the local board of trustees anyway. It is generally said that students have now freed themselves from institutional restrictions upon their individual and social behavior, while faculty members control faculty affairs with no restraint from administrators or trustees. So what difference does it make whether or not there is a lay board of trustees with the authority of government at the level of the individual campus?

I happen to believe that it does make a good deal of difference. I think faculty management of a public college or university and student conduct within a public college or university ought always and continually to be subject to the restraining influence of a lay governing board. And I believe strongly that this restraining influence needs to be exercised on a campus-by-campus basis. The state-wide governing board — indeed any multi-campus governing board — is too far removed from the day-to-day, week-to-week problems of the individual campus. Moreover, the state-wide governing board is not perceived as having as interest in or commitment to the individuality of a particular campus.

Faculty members are professional practitioners of instruction, research, and public service. They are professional practitioners usually of substantial personal competence. But faculty members are like all professional practitioners; they are likely to develop a kind of expertise that can border upon arrogance and tend to ignore the interests of those very persons they are supposed to be serving. Moreover, faculty members in their individuality and in their preoccupation with intellectual achievement are apt to forget about the non-intellectual factors of human life. Faculty members need the leavening influence of laymen interested in and supportive of their endeavor but also providing a linkage to an external world beyond the academic walls. And much the same can be said about students.

In the state-wide and multi-campus systems we leave the president and his or her immediate administrative associates to provide the linkage to an external environment. It seems to me that the president without a campus board of trustees is left especially vulnerable to all the winds of chance and all the fires of anger that swirl within the individual academic community. I think presidents need help, and I see this help as more likely to emerge from a campus governing board of lay trustees than from any other source.

My second concern with the state-wide governing board is a concern with its capacity to have a state government point of view about public and private higher education. In fact, in some states with a state-wide governing board for public higher education, state governments have perceived the necessity to establish a state board for planning purposes, for administering a state student aid program, and for carrying on those federal government planning activities specified by the federal Educational Amendments of 1972. In these circumstances, a state has two boards in the state capitol: a state-wide governing board and a state-wide

planning and coordinating board. This organizational arrangement can be mischievous, as some events have demonstrated.

I am convinced that if a state board of higher education is to develop a state government point of view it cannot at the same time be a state-wide governing board. The first responsibility of a state-wide governing board is not to state government but to the institutions or campuses over which it exercises the authority of government. A state-wide governing board must identify with the institutions under its governing authority simply because the institutions themselves have no other lay board upon which to depend. In the long run, governors and legislators must experience disappointment with a state-wide governing board as the board finds it essential to express its allegiance to higher educational institutions rather than to state government.

In this allegiance it is unreasonable and unfair to expect a state-wide governing board to express an interest in private higher education, and even in proprietary education. I see little assistance or encouragement for private colleges and universities from a state-wide governing board. Indeed, a state-wide governing board that expressed such interest or encouragement would be recreant to its role as a governing board for public institutions of higher education.

My third concern with the state-wide governing board is its inevitable development of a centralized higher education bureaucracy separate and apart from each campus. The state-wide governing board must exercise the authority of governance over each campus in the system. In order to do so, the board must have a full-time chief executive officer of experience and stature equal or superior to the experience and stature of any campus president in the system. In addition, this chief executive officer must have adequate staff support, and this support means a full complement of staff with specialized assignments in planning and budgeting, in public affairs, in academic affairs, in health affairs, in student affairs, and in business management. The result is a substantial management bureaucracy at the state-wide level of operation.

I do not see how a state-wide governing board and its staff can achieve any real decentralization to individual campuses. State-wide authority of governance demands a substantial state-wide bureaucracy of higher education. I cannot imagine any other workable arrangement. And a state-wide bureaucracy can quickly become expensive. It can and will also tend to be restrictive of campus academic innovation and campus management.

Obviously I see the state-wide planning and coordinating board of proper authority and the campus lay governing board as the desirable structural pattern for state governance in higher education. I believe a careful, objective study of the two organizational arrangements will confirm my own judgment, a judgment based upon experience and observation.

I recognize that there are certain other structural issues about state government and higher education which I have not mentioned in this discussion. I have not said anything about the degree of separation or of integration in administrative structure that is desirable between elementary-secondary education, vocational-technical education, and higher education. I have not said anything about multi-campus systems of higher education within a state, such as the multi-campus systems in New York, Illinois, and California. I have not said anything about the autonomy of public institutions of higher education. And

believe it or not, I think a considerable autonomy in corporate status, in personnel matters, in financial matters, in management services, and in academic freedom is indispensable for an institution of higher education. Moreover, I believe I can prove that the public universities of Ohio had more such autonomy at the end of my eight years of service as chancellor than they had when I went to Columbus in 1964. I have passed over these issues not as unimportant but as not essential to the matters of primary interest here.

Our state governments require an organizational structure to develop and recommend a state government point of view about higher education services. The state government interest must express a position on such basic problems as the scope and quality of instructional and other services, access to higher education, student financing, manpower requirements, geographical dispersion, level of expenditures, and sources of income. I think a state government point of view must include protection of academic freedom and substantial autonomy of campus governance and management. I think a state government point of view must include encouragement of private higher education alongside of public higher education. The important essential decisions on all these matters will be made by governors and state legislatures, with some interpretation of those decisions by the state judiciary.

In this process of state governance on higher education, in this process of state decision making, governors and legislators would have professional advice. This advice can be provided through an executive department, a state board of higher education, or a state-wide governing board. I doubt the effectiveness of the third arrangement as an instrumentality of state government. I think we must still struggle for an effective structural arrangement between a chief executive and a state board of higher education. Perhaps there is a better device that no one has yet produced. But while we struggle for organizational effectiveness, let us not overlook the end purpose: a viable, acceptable, serviceable set of state government policies ensuring the continued performance of the indispensable outcomes of higher education. The role of states was never more critical than it is today as we prepare for the highly uncertain years that lie ahead.



## KEEPING IN TOUCH, THE CAMPUS-CAPITOL INTERFACE

Marvin D. Johnson

Let me tell you a story about reluctance that I heard a while back. The local football team was being slaughtered by an over-size visiting team that was driving the locals into the grass of the football field. The local coach was hollering from the sidelines: "Give the ball to Rodolfo. Give the ball to Rodolfo!" Rodolfo got the ball and was once again ground down. "Give the ball to Rodolfo," the coach cried. Rodolfo got the ball and was smashed. "Give the ball to Rodolfo," the coach shouted. There was a long pause in the huddle, and finally a voice called back to the Coach — "Rodolfo doesn't want the damned ball."

Perhaps we're all being a little like Rodolfo in our education duties. Maybe, like Rodolfo, we're all feeling a little bashed and battered and not too optimistic about the next play. But, the game must go on — there's too much at stake to simply give up the ball.

At the campus capitol interface, we've all seen increasing action of late. "Interface," says the *Webster's Dictionary*, "as in the surface between oil and water" — where the action is — the dictionary says. And, I could add that the campus and the capitol, in many cases, have been mixing as poorly as oil and water. We're all looking for that magic bit of soap compound that will homogenize the mixture better. We are all recognizing the ferment of educational revolution; the threat of institutional extinction mentioned by John D. Millett in *The Chronicle of Higher Education* last September, 1975, or greater political control of our institutions, noted by Donald R. McNeil in Phoenix in December, 1975. McNeil, Director of the California Postsecondary Education Commission, stirred our legislators with his talk. Quite a bit.

Here are some of my conclusions, followed by some of the reasons for arriving at these conclusions:

1. This Bicentennial Year is the time for us to start taking action in our higher education echelons to counter the rather rapid drift away from self-control and into the very muddy waters of political control of our colleges and universities. We've had some excellent studies — now, what can we do to implement them?

2. "Arrogance" is one of the words that must be dropped out of such negotiations at the capitol-campus interface. Arrogant behavior and shooting from the hip — from both sides — must be replaced with reasoning, objective action and good faith. What is best for the students, higher education — and ultimately, the state — must be taken into account.

3. Purse strings are tightening and winds of change are blowing. The tree that bends is not uprooted; we in higher education must lead the way and make our

own changes — with our knowledge — or have the changes made by less-sympathetic and less-knowledgeable forces.

4. We must "keep in touch," not only with our legislative and executive branches, but with our public. We must maintain a believable and supportable stance that demonstrates our good faith and reasonableness.

5. Changes must be made in the operation and conduct of higher education to meet these needs that are blowing in the wind — however, in advance, we must outline and define those areas where we will not bend and where we will not compromise in the interests of the greater good of a free and open quest for knowledge in our free society.

Those are my summary conclusions. Let me share with you some reasons for them.

First, let me quote to you from a Harris Poll of October 16, 1975, that was designed to determine whether our national leaders are "in touch" or "out of touch" in their activities. We in colleges and universities — higher education — came out very well. We were ranked Number 5 from the top in a list of 16. That Harris Survey showed leaders in "colleges" ranked Number 5, right after medicine, television news, banks and the press. We rated 55 percent "in touch," and 34 percent "out of touch," with 11 percent "not sure." Now compare that with the leaders in medicine who got 69 percent "in touch" and 21 percent "out of touch" with 10 percent "not sure," and you see we did rather well. Medicine was in first place in really knowing "what most people they represent or serve really think and want...." State Government, if we can take any satisfaction from these figures, rated Number 7 with a 46 percent "in touch" and a 41 percent "out of touch" rating. So our national image, according to Harris, is better than that of state legislatures. At the bottom of the list was the United States Congress with a 34 percent "in touch" rating and a 54 percent "out of touch" rating which was almost exactly the reverse of the college leaders' rating. Almost tying for last place was the Executive Branch of the Federal Government and the White House.

That Harris Survey should be good news for us in higher education because it shows we hold a fairly strong, positive image with the public. I, for one, believe in polls and surveys when they are professionally done, and I think that we are very fortunate to have come out so well in this poll which is only two months old. But, you maintain yourself in the polls by constant work. If we don't try and stay "in touch" with our students' and faculty needs — with our state governments and with our general public — if we don't work at it, we can slide, too, down to where the Congress and the White House are right now in that Harris Poll. This good public image that we have stands us in good stead when we arrive at the campus-capitol interface because there is a certain reluctance in the executive and legislative branches to attack our colleges and universities head on. As long as we try and be the "good guys" — not arrogant, but cooperative — we can maintain our positive status with the public. And, having a good strong base and a good public image is helpful when we get to the positions that I mentioned earlier, where we have decided we cannot bend — where we must firmly insist on our rights of free and open study and non-political control of academics. Then, we will need all the strength we can muster. History shows this fight to be centuries old — but, in this Bicentennial Year, it would appear that a new turbulence is erupting based on this old fight for the autonomy of colleges and universities involving the campus and the capitol.

A textbook on this subject, written by Lyman A. Glenny and Thomas K. Dalglish, from the Center for Research and Development in Higher Education at the University of California at Berkeley, is an excellent review of the situation. Many of you may have read this text, but I would certainly like to recommend it to those who haven't — and urge those who have read it to re-read it. The title of the book is *Public Universities, State Agencies, and the Law: Constitutional Autonomy in Decline*. It was published in 1973 after research supported by a federal grant. It is a good example of a fine application of federal funds to a crucial study at the proper time. Glenny and Dalglish have presented an interesting and very readable book on what we are all talking about at this conference. I pay them the highest compliment when I say that I think they wrote the book to have it understood.

What do they say about public universities and state agencies? Here is part of their opening paragraph: "Working relationships between the public university and the government which charters and funds it have long been recognized as ambiguous and undefined. The boundaries shift with the times, fads, economic conditions, and the expectations and aspirations of the public and their governmental leaders."

They go on to show that we are fast approaching the time when the boundaries will be defined — must be defined. They quote D. Waldo, who wrote an article back in 1970, in the *Public Administration Review*. He said: "As the university becomes increasingly an instrument of government there will be severe problems arising from lack of congruence between academic norms and ideology and our general governmental-political norms and ideology."

But, he said in 1970 what we're all saying now: As the universities become more involved with their capitol sponsors, there will be a clash because of differing backgrounds and goals. That "lack of congruence" he mentions has already turned into some pretty severe head butting in many states. He could see the boiling at the campus-capitol interface back in 1970.

Glenny and Dalglish talk of the three traditions in the development of American colleges and universities. They point out that academic freedom, tenure, and institutional autonomy may have some mythology attached to them, but that myths and illusions do contribute, ultimately, to reality.

Autonomy of the university dates back to medieval social organization in Europe — except for the board of trustees or board of regents idea which was American. Back in the ninth century, in Europe, the university was a separate entity along with the church and civil power. The very word "university-universitas" means corporation. The university "is a living organism, and a real person with body and members and a will of its own. Itself can will, itself can act: It is a group-person, and its will is a group-will..." one early researcher noted. The church, the university and civil power — each functioned together, separately and about equal.

If a university got in trouble with the Pope, it could appeal to the king or council; if it got in trouble with a king or the local bishop, it could appeal to the Pope; and, if the university got into trouble with a local government, it could appeal to the king and the Pope.

Way back then, universities were thought of as something special to have around and were largely left alone; they could run their affairs as they saw fit.

The universities were so poor in those times that they were very mobile. If anyone gave them too bad a time, they could just move out. They had few possessions, no great libraries and they could easily move. We could not get very far with threatening to put it all on a wagon and move now.

By the 12th century, universities were being wooed and were conceived as "republics" in the social scheme. They were poor and could wander and were highly regarded. Then, by the 16th century, they developed libraries, built buildings, developed wealth — and became more subject to the state government. State control became increasingly apparent through the 17th, 18th, and 19th centuries. Kings started hiring and firing professors. In America, non-interference by the state became the rule, and we grew with this tradition of no political interference. It's the great tradition that we are worried about today.

It was in 1819, in the Dartmouth College case of Dartmouth versus Woodward that the relationship of American colleges and state government was determined by the United States Supreme Court. The New Hampshire Legislature tried to redesign the Board of Trustees to make that body more representative of the state as a whole. The United States Supreme Court ruled that the Legislature could not do that, saying that the original charter for Dartmouth College was a contract between the College and the State and that the State could not change it because the Legislature did not have constitutional power to do so.

At that time, Daniel Webster argued for the autonomy of Dartmouth College and presented the argument that is still valid today. Webster said: "It will be a dangerous, a most dangerous experiment to hold these institutions subject to the rise and fall of political parties, and the fluctuations of political opinion. If the franchise may be, at any time, taken away or impaired, the property also may be taken away, or its use perverted. Benefactors will have no certainty of effecting the object of their bounty; and learned men will be deterred from devoting themselves to the services of such institutions ... colleges and halls will be deserted by all better spirits, and become a theatre for the contentions of politics."

All of us "better spirits" will say "amen" to what Daniel Webster said in 1819.

Glenny and Dalglish based their study on four states that have constitutional status for their universities — California, Colorado, Michigan and Minnesota — and four states that have only statutory status for their universities — Hawaii, Illinois, Maryland and Wisconsin.

They cite the landmark decision of Sterling versus The Regents of the University of Michigan in 1896. In that case, the Legislature had told the University of Michigan earlier that it had to establish a College of Homeopathy and the University finally did. Then the Legislature told the University to move the school from Ann Arbor to Detroit. The University refused and the Michigan Supreme Court finally settled the matter by saying: "The Board of Regents and the Legislature derive their power from the same supreme authority, namely, the Constitution. Insofar as the powers of each are defined by that instrument, limitations are imposed, and a direct power conferred upon one necessarily excludes its existence in the other ... they are separate and distinct constitutional bodies, with the powers of the Regents defined. By no rule of construction can it be held that either can encroach upon or exercise the powers conferred upon the other." Amen, again.

But that was in 1896, and we don't all have the constitutional position that the University of Michigan has. It was noted in the book that these outside powers continue their attempts. The truth of that statement was borne out in the December issue of *The Chronicle of Higher Education*, 1975, that said the Michigan Supreme Court had to rule all over again, 79 years later, that the State Board of Higher Education had no power to veto programs at Michigan's public universities. Time marches on and the barriers continue to be tested. There is continuing action at the campus-capitol interface.

Donald McNeil said some of these same things when he spoke before some of our legislators just last month in Phoenix. McNeil said there is a point when friendly legislators and higher education representatives must part company. That point is reached, he says, "when legislators move beyond legitimate involvement in educational affairs to unwarranted interference...when the legislature impinges on the academic integrity of our institutions. When decisions about governance, institutional management, academic policy, program planning, admission requirements, faculty duties and other related issues are made not in the halls of ivy, but in the corridors of the legislature ... they begin to nitpick; they have a position on almost every educational issue; they develop a fascination for the minute details of budgets; they pose questions of infinite variety and detail; they meddle in administrative matters and in the approval not only of academic policies, but also of new programs;...."

"They instruct the educational bureaucracy what to study, how to study it, and, at times, come perilously close to suggesting what the results of the study should be... the end result can be — and too often is — greater political control of our institutions."

Langley A. Spurlock, Assistant to the President of the American Council on Education, wrote in last summer's issue of *The Educational Record* on this subject and quoted the Carnegie Commission about the line that should be drawn for institutional independence. There were three sections of institutional independence that should be preserved, the Commission said.

"1. The intellectual, through the protection of academic freedom of expression and of free choice and conduct of research projects by faculty members and students;

"2. The academic, through acceptance of decision making by academic authorities in specified academic areas such as conduct of courses; and

"3. The administrative, through allowing substantial leeway in handling financial and personnel matters in detail."

Although I don't always agree with the Carnegie Commission, I will say, as I'm sure we all will, amen to that.

Spurlock brings up the interesting idea that perhaps we should not try to wipe out conflict; conflict may be helpful. His view is the adversary approach brings about desirable conflict — providing checks and balances in which the institutional leaders push their institutions forward and the coordination directors exert a "braking force." Spurlock may think of that as "constructive tension," but I am a little afraid of encouraging such roles.

The State University of New York, according to that *Chronicle* article in last year's December 15 issue, is trying some of that "constructive tension" right now

between Chancellor Ernest L. Boyer of SUNY and Commissioner Ewald B. Nyquist of the New York Board of Education. They are going round and round on who has the authority to establish or close graduate programs in the State of New York. The argument hasn't gone to court yet, but neither side seems to talk of "constructive tension"; in fact, Mr. Nyquist's office calls the matter "a continuing messy problem." Amen to that, also,

Nyquist is also quoted on this matter of autonomy as saying: "...the old notion of complete institutional autonomy is out. In this state, there is a pretty clear understanding of calculated interdependence. Nobody can do as he damn well pleases."

Boyer answers: "The issue is not quality. Nobody is defending non-quality... the issue is not statewide coordination. The issue is who runs the university." And there we are again.

And, higher education leaders say that review of graduate programs, for instance, might very well be necessary, the article goes on. But the institutions themselves, and not outside agencies, should have the final say.

There are two other fine quotes in that article attributed to McAllister H. Hull, Jr., University Dean at the State University of New York at Buffalo, who said that state education departments should have no role in carrying out decisions based on review of graduate programs. By doing that, the department "... takes the role of a ministry of education, which, so far at least, is alien to the American experience." And then, in arguing that higher education, the colleges and universities should correct their own programs, he said: "... if a surgeon is asleep when the patient needs an appendectomy, the proper response is to wake the surgeon, not to start the operation without him."

On the other hand, a quote from John D. Millett appeared in the September 22 issue of the *Chronicle for Higher Education*, who said: "My assessment of current circumstances is that present arrangements for governance within individual colleges and universities tend to be too fragmented, too indecisive, and too lacking in support of leadership to be competent to cope with the demands of change...and...the state board of higher education...is the one and only state government agency competent to develop and provide a creative management response to economic circumstances." Now, of course, he does not say that the colleges and universities cannot do it — only that if we are to have an agency in the state make changes, it would be the state board of education. I hate to admit that Mr. Millett might be right, perhaps he is. Maybe it would be necessary to see the board of education before I made any further judgments. After all, I did say that we have to show good faith and reasonableness.

We must not shoot from the hip, any more than we can support other persons who shoot from the hip. It was M.M. Chambers, professor of educational administration at the Illinois State University, who said that the first six months of 1975 was "...a peak time for panicky, ill-considered, shoot-from-the-hip attempts in legislatures and in governors' offices to impose unwise and unconstitutional mandates on higher education."

Well, shooting from the hip in return won't help much. We all need some kind of figurative gun control law to stop all this swivel-holster expression of ideas.

Now in my conclusions I said that this Bicentennial Year should be a year for action. We are now all aware of the problem, and enough studies have been conducted.

*The American Association of University Professors Bulletin*, in September of 1973, had a study of more than 35 pages based on research at Ohio, Wisconsin, Nebraska and Illinois. That seemed very comprehensive. Then there is the Carnegie Commission study on the governance of higher education, and the report from the Education Commission of the States, and the State Agency Institutional Interface Conference Report from Princeton, in December, 1974.

What strikes you when you read some of these reports is that there is no section that says, "Now — here's what higher education should do — starting right away." It seems to me that this Bicentennial Year is a good time to set up action study groups that try to produce some remedies and outlines for action.

We do have a crisis and now is the time for us to try to formulate action. We need outlines for action, not only for ourselves, but for use with our legislative friends. They have to know some of this background we have talked of tonight. In addition, in order to explain the crisis to the general public we have to know where we are going ourselves. It's hard to plug for the need of preserving some autonomy when the public does not even understand that autonomy is threatened or that political control is looming. It is difficult to equate these present needs to the old "Bucks to Beat Sputnik" campaign that everyone could understand and participate in.

Let me repeat my five conclusions:

1. This Bicentennial Year is the time for us to start taking action in our higher education echelons to counter the rather rapid drift away from self-control and into the very muddy waters of political control of our colleges and universities. We have had some excellent studies — now what can we do to implement them?

2. "Arrogance" is one of the words that must be dropped out of such negotiations at the capitol-campus interface. Arrogant behavior and shooting from the hip — from both sides — must be replaced with reasoning, objective action and good faith. What is best for the students, higher education — and, ultimately, the state — must be taken into account.

3. Purse strings are tightening and winds of change are blowing. The tree that bends is not uprooted; we in higher education must lead the way and make our own changes — with our knowledge — or have the changes made by less-sympathetic and less-knowledgeable forces.

4. We must "keep in touch," not only with our legislative and executive branches, but with our public. We must maintain a believable and supportable stance that demonstrates our good faith and reasonableness.

5. I am convinced that changes must be made in the operation and conduct of higher education to meet these needs that are blowing in the wind — however, in advance, we must outline and define those areas where we will not bend and where we will not compromise in the interests of the greater good of a free and open quest for knowledge in our free society.

Those are my conclusions, but before I finish I would like to quote to you from the Constitution of Arizona, Article Eleven, Section Six, in part:

"The University and all other state educational institutions shall be open to students of both sexes, and the instruction furnished shall be as nearly free as possible."

I am not a lawyer, and I know when the Constitution says "as nearly free as possible" that the founding fathers were probably talking about money. But, I think I could make a very good case for the argument that they were also thinking about freedom of thought when they said "as nearly free as possible." I would like to see both concepts enforced in this state and across the nation.

#### REFERENCES

*Public Universities, State Agencies, and the Law: Constitutional Autonomy in Decline*, Lyman A. Glenny and Thomas K. Dalglish, Center for Research and Development in Higher Education, University of California, Berkeley, 1973.

Statewide Coordination: Complement and Conflict, Langley A. Spurlock, *Educational Record*, Summer, 1975, American Council on Education.

"The Board of Education and SUNY at an Impasse," Malcolm G. Scully, *The Chronicle of Higher Education*, Dec. 15, 1975.

"Politics, Not Formulas, Now Cutting Budgets," Jack Magarrell, *The Chronicle of Higher Education*, Sept. 22, 1975.

Higher Education Issues and the Legislative Process, Donald R. McNeil, Director, California Postsecondary Education Commission, Dec. 7, 1975, Western Interstate Commission for Higher Education, Phoenix, Arizona.

Public Higher Education, reports on Illinois, Nebraska, Wisconsin and Ohio, *American Association of University Professors Bulletin*, September, 1973.

"Flexibility for Whom: The Case of Forced Savings in Budgeting for Higher Education," Anthony W. Morgan, *Educational Record*, Winter, 1975.



## FEDERAL EFFECTS ON STATE AND INSTITUTIONAL POLICIES

Allan W. Ostar

The effects of federal action on state and institutional policies is not a new subject. The Morrill Act of 1862 established a pattern of public higher education in the states which exists to this day. The G.I. Bill following World War II introduced the new concept of "mass" or universal higher education and gave new meaning in each state to the definition of educational opportunity.

What is new is the scrutiny, the critical questioning, of federal action by the higher education community. The recent and steadily growing concern about the impact of federal activities involves several questions. Are the unintended side effects of federal programs occasionally great enough that they obscure the importance and the value of the actual program? Are federal actions a response to actual needs within the higher education community, or is the need generated by the federal government? Do federal programs accomplish what they are intended to?

These are questions which I hope are not only being asked on campuses throughout the country, but on Capitol Hill and in the offices of HEW as well.

Many of you have read the article in the December 15 issue of the *Chronicle of Higher Education*, "Is Uncle Sam Muscling In?" While the article states that federal officials deny an attempt to obtain tight bureaucratic control over the colleges, I think we have to look at the reality as well as the well-meaning intent. Do the ends justify the means?

For example, consumerism seems to be the password for the remainder of this decade. Few people would deny students their rights to be protected against fraudulent consumer practices. A year ago the *Boston Globe* ran a shocking series on the number of students who enrolled in certain proprietary institutions following deceptive high-pressure sales recruiting practices and who were left in the end considerably poorer, probably in debt, ill-trained and unemployed. There is little doubt that students must be protected from these types of shoddy practices. However, in attempting to clean up a minority of postsecondary educational institutions, the Office of Education is drawing up policies which affect all of higher education. In fact, it appears to be charting a course toward federal accreditation.

In the wake of the student consumerism movement, the U.S. Office of Education has proposed new legislation on institutional eligibility standards. As an aside here, it should be noted that no one in the higher education community was given the opportunity to consult or advise while the legislation was being written. The fact that the higher education associations were able to comment on the finished legislation during a meeting was an afterthought.

As proposed, the U.S. Commissioner of Education would have the authority to prescribe standards of institutional financial responsibility. As proposed, the Commissioner would have the authority to prescribe how institutions maintain their student records. As proposed, the Commissioner would have the authority to define ethical standards for eligible institutions. As proposed, this legislation usurps the accrediting responsibilities of state and private accrediting bodies. While the intended end may be to protect students from unscrupulous entrepreneurs, the means actually result in the U.S. Office of Education setting up its own accrediting standards which, in fact, go far beyond whether or not an institution maintains an appropriate program quality.

I also suggest that before the Office of Education revises its regulations in such a fashion, it should attempt to fully execute the regulations it already has to see whether or not change is needed. The current student loan scandal involving the West Coast schools might not have reached its present proportions had OE followed its own procedures and not approved loans for a year and a half for schools which were not accredited.

I also am very concerned with those federal actions which I do not believe accomplish their intended result, and, in fact, may be counterproductive.

During the past decades we have witnessed a shift in federal funding patterns. From the fifties, higher education was the recipient of project grant funding. The project grant was not intended to fit into an overall scheme of institutional planning or educational philosophy. It was aimed primarily at some scientific or technological advance in a field of expertise of a particular faculty member or faculty members. Project grants have proved beneficial. They have expanded the body of scientific knowledge and applied technology, advanced our medical science, and given us Gatorade. Project grants do have drawbacks. Probably no one expressed it better than the president of a major state university who remarked that federal project grant support was turning his institution into a holding company for academic entrepreneurs. The loyalties of his faculty no longer were to the goals and objectives of the institution, but to their research projects and to the federal agencies that supported them.

A second drawback of project grant funding is that it forces the research energies of an institution into whatever slot the federal government happens to be funding that year. It is difficult to maintain a continuity of direction when the agency, be it the National Science Foundation or the National Institutes of Health, changes its priorities every year. I think the academic integrity of an institution is maintained more favorably under the institutional funding provided by the Land Grant Act, which enables a university to identify its own directions for research and development, not fulfill an agency's agenda. I think the advances in food and fiber technology made by land-grant institutions compare quite favorably with the project grant method.

Additionally, the land-grant institutional funding has not been an inroad for federal interference, as has the project grant. I'm sure you are familiar with the wrath which NSF incurred from Senator Proxmire's committee last year. Studies into human emotion, most particularly love, conducted by two universities did not enamor the Senator. The result was a challenge of the whole peer-review system, and a serious challenge by Congress to set up its own review system of project grants.

During the Nixon administration, we saw a shift in federal funding. Some support of programs for states and local governments was eliminated when the administration passed its State and Local Fiscal Assistance Act of 1972. Under revenue sharing, the support for the programs theoretically would continue, but would come from the state, eliminating the middle man in the form of the federal government. That is the intent. However, as some critics have pointed out, states do not have to continue supporting those programs and some states have in fact used revenue-sharing funds to cut state taxes. The money which higher education has received from revenue sharing has been minimal.

Furthermore, revenue sharing, because it is based upon a formula of population and revenue effort, bears out that old saying, "The rich only get richer." States which are financially well off and generate more revenue through income taxes receive more in revenue sharing than the poorer states which have a greater need for revenue sharing funds. A more equitable plan would be a form of countercyclical aid, such as the type proposed by Senators Muskie and Humphrey. The Intergovernmental Countercyclical Assistance Act would provide federal assistance to state and local governments during economic crises in order to maintain fiscal equilibrium. I do not think that on the whole revenue sharing has accomplished the fiscal stability which it intended.

Accompanying this shift toward revenue sharing, legislation during the Nixon administration diminished institutional aid in favor of student aid. Much federal money now is channeled through the students to the institution, rather than the other way around. The intent of student-centered aid is to increase access. The result has been a decline in full-time enrollment of high school graduates.

Between 1969 and 1973, the percent of high school graduates attending college decreased by 13.8 percent. The largest decreases occurred in families with yearly incomes below \$15,000 a year. Enrollment of students from these families declined approximately 20 percent. Enrollment from families earning over \$15,000 a year declined about 8 percent.

Why has the result of federal student aid programs so dramatically countered the intent? Several reasons. One, appropriations for higher education generally have not kept pace with the rate of inflation. This particularly is true in those states hard hit by the recession with high unemployment and few natural resources on which to fall back. And, importantly, no plan of countercyclical aid from the federal government. A recent AASCU survey of appropriations for higher education found that only 16 states were able to meet the increase in the consumer price index, which was 11.9 percent between September 1974 and September 1975. Appropriations increases in the remainder of the states fell below 12 percent, including eight states which increased appropriations by less than 4 percent.

With a gap between appropriations and expenses, and with no federal institutional aid programs, colleges and universities are left with no good alternatives. They can cut back on staff, delay purchase of supplies, cancel programs, and increase student-faculty ratios; or they can increase student tuition. And I think that it is a fairly well established fact now that tuition increases adversely affect success. According to the study done by the National Commission on the Financing of Postsecondary Education, every \$100 increase in tuition results in enrollment declines from 3.1 to .7 percent, depending on family income.

Currently, federal student aid plays a distorted role in improving access. The cost of educating federally-aided students far exceeds the cost of tuition and fees. Institutional aid in the form of cost-of-education payments based upon some formula of federally-aided students was authorized by the Higher Education Amendments of 1972. Despite the efforts of Senators Robert Byrd and Birch Bayh and several others, neither Congress nor the administration has requested funding for this aid program. The result is that every time a federally-aided student enrolls, it costs the college or university money — money which all too frequently can be recaptured only by increasing tuition. That result is obvious: fewer students can afford the tuition, more students require student aid, and the whole cycle starts all over again.

Because of this federal stance on student aid, federal student aid as a percentage of the cost of instruction covered by tuition has shrunk. In 1971, federal grants averaged 69 percent of student tuitions; in 1974 the figure dropped to 53 percent. According to Charles Saunders, director of governmental relations for the American Council on Education, schools — and states in some instances — have been forced to provide a larger share of student aid from their own resources, compounding "their already serious fiscal problems and contributing to an excessive dependence on loans by students to finance their educations."

Another factor imperils access, and that is the temptation for states to substitute federal dollars for state dollars, decreasing state appropriations for higher education and raising tuitions. As federal student aid programs do not require a maintenance of effort by the states, it is fairly easy to raise tuitions and "capture" federal student aid money. This may free state resources for use elsewhere, but it does nothing for student access. This course of action has been advocated recently in several states.

The State Education Commissioner of New York, Ewald Nyquist, advocates charging tuition at the tuition-free City University of New York in order to ease that city's fiscal crisis. Nyquist's reasoning is that if tuition were charged, students would be eligible to receive state and federal student aid. Nyquist contends that the student aid received will offset the tuition increase for most lower and middle income families. Unfortunately, the decline in college attendance does not bear out Mr. Nyquist's optimism.

The situation in Pennsylvania is a good case in point. Pennsylvania now requires that all students seeking state funds must first apply for federal aid. Students who do not file for aid under the Basic Educational Opportunity Grant program face cancellation of the next payment of their state grant. Because of this, the Pennsylvania Higher Education Assistance Agency expects that the state will "capture" almost \$40 million by the end of the academic year. On the surface, it does not seem unreasonable to ensure that students apply for federal aid for which they may be eligible. However, the reason that Pennsylvania will increase its capture of federal dollars this year is because it increased its tuitions this year. According to the AASCU annual tuition survey, Pennsylvania state colleges now have among the highest tuitions in the nation. Median tuition for the state's colleges is over \$900, as compared with a national median of \$537. And, while the enrollment in state colleges and universities increased 5.9 percent on a national average this fall, the enrollment increase in Pennsylvania was only 2.3 percent.

The course of action advocated for the City College of New York and executed in Pennsylvania probably will not stop there. Unfortunately state colleges in New

Jersey and Massachusetts face severe cut-backs in state funds. Legislators and politicians in those states can help clear their public consciences by telling citizens that the students won't suffer because they will be eligible for federal student aid.

The substitution of federal student aid dollars for traditional state support may have tragic consequences for student access because of the unreliability of federal aid programs.

U.S. Commissioner of Education T.H. Bell testified some time ago that appropriations for the BEOG program would be insufficient to cover the number of students eligible for the program this year. It is expected that the greater number of students eligible this year would reduce the size of the awards. The size of the average BEOG award has never been great.

A survey conducted by the American Council on Education on the impact of federal student assistance programs found that the average BEOG grant in 1973 was \$349. The survey of campus financial aids officers also found an increasing administrative workload, primarily because of the uncertainty over funding and procedures associated with the needs analysis. Ninety percent of the officers felt that the needs analysis resulted in an unrealistic amount for the contribution that a student's family was expected to pay. Most significantly, in those institutions which experienced a lower enrollment than expected, three-fourths of the officers believed that lack of federal aid was a factor.

I think we only have to look at the political maneuvering between Congress and the President over recent appropriations bills to see how tied up student aid monies can become, how they can be delayed, and cut.

The shift toward funding through student aid was supported by some people on the grounds that it would avoid federal control. This has proved to be a fallacy.

In order for an institution to be eligible for Guaranteed Student Loan funds, it now must keep a file on the career outcomes of its alumni so that it can show prospective students the employment and salary records of its graduates in certain fields.

Hillsdale College, a private institution in Michigan, recently informed HEW that it did not have to comply with Title IX regulations because it did not receive any federal aid. HEW informed Hillsdale College that indeed it had to comply with the regulations because some of its students were receiving G.I. benefits.

Student aid without federal strings is an illusion which can be quickly shattered. During the campus demonstrations of the late '60s and early '70s, former Congresswoman Edith Green sponsored legislation to cut off federal aid to disruptive students. Now, what is a disruptive student? Who makes that definition? The federal government? That is direct interference in the governance and authority of the campus.

The most cost-effective education the federal government has sponsored is the Land-Grant Act. It also is the program with the fewest strings. The Land-Grant Act authorizes unrestricted funds for institutions. It takes few bureaucrats to administer the program because there are no regulations to draw, no personnel to supervise enforcement. At the institution's end, there is no record-keeping, no forms to fill out, and the land-grant funds have maximum utilization.

Student aid programs offer the reverse.

Recent programs and regulations of HEW have been repeated thrusts toward more strings, more federal authority, and greater costs. The 1202 Commissions are a good example of increasing federal control. Section 1202 dictates how states will define postsecondary education, how states will design a planning apparatus, and who will be represented on the planning commission.

Federal funds, for whatever specific project, also have placed institutions under the jurisdiction of the federal government's broadly interpreted social justice reforms.

An excellent example of how extensive this authority has become is the recent charge by HEW's office of civil rights against the state of Maryland which could result in all of the state's public institutions losing federal funding. OCR will begin administrative proceedings against the state on the grounds that it has failed to comply with key points in its desegregation plan. To sustain its charges, OCR mentions as an example the fact that while Morgan State College, a black institution, has an urban studies program, the College Park Campus of the University of Maryland was authorized to offer an urban program. According to OCR, the duplicative programs will not correct the racial imbalances among the state's institutions. Thus, on the principle of racial desegregation, the federal government is telling the state of Maryland which programs its institutions may or may not offer.

I have very serious reservations about federal interference at the program level in colleges and universities, regardless of the overall goal or objective. This is not the first time the federal government has attempted to exert its influence in this area. For example, following student protest during the height of the Viet Nam war, several institutions dropped ROTC on campus. In retaliation, some members of Congress attempted to pass legislation which would have prohibited any defense contract awards or military graduation work done at those institutions.

There is, I am sure, not one campus administrator who consciously would support unsafe working conditions, discrimination in hiring, or favoritism in student development based upon sex. Administrators who have not enthusiastically endorsed these federal regulations have been unjustly criticized as being against social reform. What may appear to be an unwilling commitment to social reform actually is a very real concern with the financial and social costs of complying with all federal regulations. Again, it is a question of the means justifying the ends.

A study conducted by the American Council on Education reports that the financial exigencies experienced by institutions in this decade are attributable in large part to the added costs of implementing a larger and larger number of federally mandated social programs. The study found that at six schools in 1974-75, the cost of implementing the federally mandated social programs was between \$9 and \$10 million, representing between 1 and 4 percent of the operating budgets of the respective institutions. These are funds which will not be reimbursed through increased state appropriations or aid from the federal government. If the handrails in your institution happen to be 43 inches high instead of 42 inches, the cost of replacing all those handrails, which you must do, must come from somewhere.

The Maine Maritime Academy found that government regulations and new statutes governing equal opportunity, affirmative action, unemployment compensation, occupational safety and the environments added \$55,000 to its annual expenses. The enrollment at the Academy is approximately 600 students, which means that the cost of complying with government regulations is \$100 per student.

If a college has to increase tuition to help pay its compliance bills, the decrease in education access seems to outweigh efforts the institution has to make to prove that it is not discriminating in its enrollment and scholarship procedures. An institution which has to hire personnel to research the composition of the available labor pool simply reduces the funds it might have to fill positions from that labor pool.

In moving from good faith efforts to well-documented efforts, HEW has increased greatly the administrative costs of colleges and universities.

The effect which the federal government can have on colleges and universities and on state policies toward higher education is a tremendous one. It can be a positive effect, or a negative effect. We must realize that the federal government is here to stay, as is its influence. Crying out against federal dominance is a voice in the wilderness. We would be far better off to employ the voice of reason, to counsel at every possible opportunity for the need for caution and examination of federal action before that action becomes law. We should volunteer our assistance in helping evaluate possible programs. We should practice maximum cooperation in working with the federal government to overcome problems. Through these kinds of activities we may well be able to ask those important questions and have them answered. Would the program accomplish its intent? If not, why not? Would that regulation have undesirable side effects? How can that be overcome? Does that regulation answer a need within higher education? Or is it self-serving the federal bureaucracy?

Higher education must demonstrate its willingness to work with Congress and the executive branch to answer these important questions. It is only when these questions become answered first that the federal influence can assuredly be a positive one.

## COORDINATION OF PROGRAM DEVELOPMENTS IN POSTSECONDARY VOCATIONAL EDUCATION

T. Harry McKinney

The need for coordination of program developments in postsecondary vocational education has grown rapidly during the past few years as competition for students has increased and financial support for programs and facilities has become more difficult to obtain.

This need was reflected in the Education Amendments of 1972 which attempted through the wording of Sections 1202 and 1203 to place responsibility for planning related to such programs within the broader framework of planning for all postsecondary educational resources. It can be seen again in proposed amendments to the Vocational Education Act of 1963, which offer a variety of approaches to planning and administration of vocational education programs.

What will happen during the weeks ahead as Congress considers these and perhaps other amendments to existing legislation is not clear. One thing is certain, however. The results will have a major impact on coordination of program developments at the state level for several years to come.

The purpose of this paper is to review major features of proposed legislation as a means of identifying issues and alternatives related to coordination of programs. Before doing that, however, it may be helpful to review some of the provisions in the Vocational Education Act of 1963 and the Higher Education Act of 1965.

### Vocational Education Act of 1963

The Vocational Education Act of 1963, as amended through December 31, 1974, is divided into ten parts as follows: Part A — General Provisions; Part B — State Vocational Education Programs; Part C — Research and Training in Vocational Education; Part D — Exemplary Programs and Projects; Part E — Residential Vocational Education; Part F — Consumer and Homemaking Education; Part G — Cooperative Vocational Education Programs; Part H — Work-Study Programs for Vocational Education Students; Part I — Curriculum Development in Vocational and Technical Education; and Part J — Bilingual Vocational Training.

Parts A and B are the only ones that require attention here. Part A contains six sections designated as Sections 101 to 104 and 107 to 108. Part B contains four sections designated as Sections 121 to 124. Headings are shown in Exhibit 1.

Section 101 contains a declaration of purpose which calls for federal grants to states to assist them (1) in maintaining, extending, and improving existing



Exhibit 1

OUTLINE OF PROVISIONS IN PARTS A AND B OF THE  
VOCATIONAL EDUCATION ACT OF 1963, AS AMENDED THROUGH 1974

Part	Section	Heading
A	101	Declaration of Purpose
	102	Authorization of Appropriations
	103	Allotments among States
	104	National and State Advisory Councils
	107	Limitation on Payments
	108	Definitions
	121	Authorization of Grants
	122	Uses of Federal Funds
	123	State Plans
	124	Payments to States

programs of vocational education, (2) in developing new programs of vocational education, and (3) in providing part-time employment for youths who need the earnings from this employment to continue vocational training on a full-time basis. These activities in turn are intended to create a situation where persons of all ages in all communities at both secondary and postsecondary levels "will have ready access to vocational training or retraining which is of high quality, which is realistic in the light of actual or anticipated opportunities for gainful employment, and which is suited to their needs, interests, and ability to benefit from such training."

Section 102 contains provisions related to authorization of appropriations. It authorizes specific amounts for programs described in Parts B and C and "such sums as may be necessary" for development and administration of state plans, activities of state advisory councils, and activities related to evaluation of programs and dissemination of results.

Section 103 contains provisions related to allotments from sums appropriated under Section 102. It requires the Commissioner to reserve an amount not to exceed \$5 million in any fiscal year for transfer to the Secretary of Labor to finance national, regional, state, and local studies of manpower needs. It then lists procedures to be followed by the Commissioner in making allotments among the states.

Section 104 contains provisions related to national and state advisory councils. Subsection (a) calls for establishment of a National Advisory Council on Vocational Education consisting of 21 members appointed by the President who meet seven stated requirements in terms of backgrounds and who are given four areas of responsibility. The areas of responsibility call for the Council (1) to advise the Commissioner on certain matters related to administration of programs at the federal level, (2) to review the administration and operation of programs at the state level, (3) to conduct independent evaluations of such programs, and (4) to review possible duplication of programs at postsecondary and adult levels within geographic areas.

Subsection (b) requires any state that desires to receive a grant under this legislation to establish a state advisory council which is appointed by the governor or an elected state board of education, which includes persons who meet nine stated requirements in terms of backgrounds, and which is given three areas of responsibility. The areas of responsibility are (1) to advise the state board for vocational education on the development and administration of state plans, (2) to evaluate vocational education programs, services, and activities, and (3) to prepare and submit an annual report to the national advisory council through the state board.

Section 107 prohibits use of funds for religious purposes and states that funds may be used for residential vocational education schools only to the extent that operation of such schools is consistent with general regulations and other stated requirements.

Section 108 contains definitions of terms. Most important in relation to proposed amendments is the definition of a state board for vocational education. It reads as follows:

The term "State Board" means a State Board designated or created by State law as the sole State agency responsible for the administration of vocational education, or for supervision of the administration thereof by local educational agencies, in the State.

Section 121 authorizes the Commissioner to make grants to states as provided in Sections 102 and 103.

Section 122 contains provisions related to purposes for which grants may be used. Subsection (a) lists purposes that require use of funds in accordance with state plans. Subsection (b) allows use of funds for development and administration of the state plan as well as evaluation and dissemination activities. Subsection (c) establishes minimum percentage requirements or "set-asides" for certain purposes, including a requirement that no less than 15 percent of the total allotment to a state for any fiscal year must be used to provide vocational education for persons "who have completed or left high school and who are available for study in preparation for entering the labor market."

Section 123 requires any state that desires to receive its share of appropriated funds to submit a state plan at such time, in such detail, and containing such information as the Commissioner deems necessary. The plan must meet 18 requirements for approval by the Commissioner. The first five are most important here. Briefly, they specify a state plan that (1) has been prepared in consultation with the state advisory council, (2) designates the state board as the sole agency for administration of the state plan or supervision of its administration by local educational agencies, (3) has been submitted only after the state board has followed certain procedures related to a public hearing and distribution of appropriate information, (4) sets forth a long-range program plan which has been prepared in consultation with the state advisory council and meets several stated requirements, and (5) sets forth an annual program plan which has been prepared in consultation with the state advisory council and meets other stated requirements.

Section 124 contains provisions for payments to states. Among other things, it provides that payments may not exceed 50 percent of state and local expenditures in carrying out state plans.

#### Higher Education Act of 1965

Let us turn now to the Higher Education Act of 1965. As a result of the Education Amendments of 1972, this legislation contains some provisions that are very important in terms of proposed amendments to the Vocational Education Act. The provisions appear in Sections 1202 and 1203 of Title XII and Parts A, B, and C of Title X.<sup>2</sup> Sections 1202 and 1203 are shown in Exhibit 2.

As you may know, Section 1202 has been highly controversial since it became part of the Higher Education Act.<sup>3</sup> It requires every state that wants to receive assistance under Section 1203 or Title X to establish or designate a state postsecondary education commission that is "broadly and equitably representative of" the general public and three broad categories of postsecondary institutions — public, private nonprofit, and proprietary. It provides further that this representation shall include community colleges, junior colleges, postsecondary vocational schools, area vocational schools, technical institutes, four-year institutions of higher education, and branches of these institutions.

Section 1203 has also been a matter of controversy because it appears under the heading "Comprehensive Statewide Planning" but contains wording that can be interpreted to mean something less than that. More specifically, it authorizes the Commissioner to make grants to any state commission established or designated in accordance with the requirements of Section 1202 "to enable it to expand the

Exhibit 2

SECTIONS 1202 and 1203 OF THE HIGHER  
EDUCATION ACT OF 1965 AS AMENDED IN 1972

STATE POSTSECONDARY EDUCATION COMMISSIONS

"SEC. 1202. (a) Any State which desires to receive assistance under section 1203 or title X shall establish a State Commission or designate an existing State agency or State Commission (to be known as the State Commission) which is broadly and equitably representative of the general public and public and private nonprofit and proprietary institutions of postsecondary education in the State including community colleges (as defined in title X), junior colleges, postsecondary vocational schools, area vocational schools, technical institutes, four-year institutions of higher education and branches thereof.

Post, p. 325.  
Ante, p. 312.

"(b) Such State Commission may establish committees or task forces, not necessarily consisting of Commission members, and utilize existing agencies or organizations, to make studies, conduct surveys, submit recommendations, or otherwise contribute the best available expertise from the institutions, interest groups, and segments of the society most concerned with a particular aspect of the Commission's work.

"(c) (1) At any time after July 1, 1973, a State may designate the State Commission established under subsection (a) as the State agency or institution required under section 105, 603, or 704. In such a case, the State Commission established under this section shall be deemed to meet the requirements of such sections for State agencies or institutions.

79 Stat. 1220,  
1262.  
20 USC 1005,  
1123.

"(2) If a State makes a designation referred to in paragraph (1) —

Ante, p. 290.

"(A) The Commissioner shall pay the State Commission the amount necessary for the proper and efficient administration of the Commission of the functions transferred to it by reason of the designation; and

"(B) the State Commission shall be considered the successor agency to the State agency or institution with respect to which the designation is made, and action theretofore taken by the State agency or institution shall continue to be effective until changed by the State Commission.

"(d) Any State which desires to receive assistance under title VI or under title VII but which does not desire, after June 30, 1973, to place the functions of State Commissions under such titles under the authority of the State Commission established pursuant to subsection (a) shall establish for the

20 USC 1121  
Ante, p. 288

purposes of such titles a State Commission which is broadly representative of the public and of institutions of higher education (including junior colleges and technical institutes) in the State. Such State Commissions shall have the sole responsibility for the administration of State plans under such titles VI and VII within such State.

#### **"COMPREHENSIVE STATEWIDE PLANNING**

Ante, p. 312. "SEC. 1203. (a) The Commissioner is authorized to make grants to any State Commission established pursuant to section 1202(a) to enable it to expand the scope of the studies and planning required in title X through comprehensive inventories of, and studies with respect to, all public and private postsecondary educational resources in the State, including planning necessary for such resources to be better coordinated, improved, expanded, or altered so that all persons within the State who desire, and who can benefit from, postsecondary education may have an opportunity to do so.

"(b) The Commissioner shall make technical assistance available to State Commissions, if so requested, to assist them in achieving the purposes of this section.

Appropriation. "(c) There are authorized to be appropriated such sums as may be necessary to carry out this section."

Source: **Public Law 92-318**, 92nd Congress, S. 659, Education Amendments of 1972, June 23, 1972, pp. 89-90.

scope of the studies and planning required in Title X through comprehensive inventories of, and studies with respect to, all public and private educational resources...." It also requires the Commissioner to provide technical assistance to such commissions on request.

Title X has three parts with numerous sections and subsections, all included under the heading "Community Colleges and Occupational Education." Part A authorizes appropriations for establishment and expansion of community colleges. Part B authorizes appropriations for the development of occupational education programs. Part C requires organizational units within the Office of Education to administer or coordinate these and other programs.

Parts A and B are particularly important here because they give Section 1202 state commissions two sets of responsibilities. Part A requires that they develop statewide plans for establishment and expansion of community colleges. Part B requires that they conduct comprehensive programs of planning for occupational education.

What all of this means is that state commissions required under Section 1202 were given responsibility for three types of planning — planning for establishment and expansion of community colleges, planning for occupational education programs, and planning related to all postsecondary educational resources. However, as you may know, Title X has never been funded. Furthermore, funding under Section 1203 has been accompanied by widespread concern about the nature of representation on state commissions that have been established or designated as a result.

This concern can be traced primarily to the fact that the Commissioner has not published some proposed rules and regulations for implementation of Section 1202 that were developed by a task force for that purpose. Instead, he gave the governor of each state or eligible territory three options regarding the establishment or designation of state commissions and left it to the governor to interpret the wording of the law. The options were (1) establishment of a new commission, (2) designation of an existing state agency or state commission, and (3) augmentation of an existing state agency or state commission.

Options chosen by the governors are shown in Exhibit 3. Among other things, this tabulation of their responses to the Commissioner indicates that most governors chose either the second or the third option. More detailed examination of their responses reveals further that they generally chose to designate or augment state boards for higher education in attempting to meet the requirements of Section 1202.

#### **Basic Structures**

One of the reasons for these concerns can be illustrated by a series of diagrams which are shown in Exhibits 4, 5, and 6.

The first three diagrams (Exhibit 4) show basic patterns among the different types of agencies responsible for supervision, administration, coordination, or governance of educational programs on a statewide basis. The agencies are classified here as state boards of education (SBE), state boards for vocational education (SBVE), and state boards for higher education (SBHE). Members of these boards may be chosen by the electorate (E), the governor (G), or the

Exhibit 3

STATES AND ELIGIBLE TERRITORIES WITH  
SECTION 1202 STATE COMMISSIONS ON MARCH 1, 1975

New Commission	Existing Agency or Commission	Augmented Agency or Commission	No Commission
Alabama	Connecticut	Arkansas	Colorado
Alaska <sup>1</sup>	Florida	Hawaii	North Carolina
Arizona	Idaho	Maine	Tennessee
California <sup>2</sup>	Illinois	Massachusetts	Wisconsin
Delaware	Indiana	New Jersey <sup>5</sup>	
D.C.	Iowa	North Dakota <sup>3</sup>	
Georgia	Louisiana	Pennsylvania	
Kansas	Maryland	Rhode Island	
Kentucky	Michigan	South Carolina	
Mississippi	Minnesota <sup>4</sup>	Utah	
Nebraska	Missouri	Washington	
Nevada <sup>3</sup>	Montana	Guam	
New Hampshire <sup>2</sup>	New Mexico	Puerto Rico	
South Dakota <sup>2</sup>	New York		
Texas	Ohio		
Vermont	Oklahoma		
West Virginia <sup>3</sup>	Oregon		
American Samoa	Virginia <sup>1</sup>		
Virgin Islands <sup>1</sup>	Wyoming		

<sup>1</sup> Not established for funding during 1974-75

<sup>2</sup> Established prior to March 1, 1974

<sup>3</sup> Includes all members of an existing body

<sup>4</sup> New commission replaced by existing body

<sup>5</sup> Augmented after original designation

Source: Aims C. McGuinness, Jr., T. Harry McKinney, and Richard M. Millard.  
*The Changing Map of Postsecondary Education*. Denver: Education  
Commission of the States, April 1975, p. 79.

legislature (L), depending on the state, which explains the use of dotted lines. Other complexities, such as the existence of two or more state boards for higher education, are not reflected in the diagrams but may be highly important in a particular state.

Diagram 1 shows a state that has only one board responsible for educational programs on a statewide basis. Such a board is usually referred to as a state board of education. In other words, there is no independent board for administration of vocational education programs and no independent board for coordination or governance of higher education.

Diagram 2 shows a state that has two boards for these purposes. One is a state board of education, which is responsible for general supervision of elementary and secondary schools and has also been designated as the state board responsible for administration of vocational education programs. The other is a state board for higher education, which is responsible for coordination or governance of public institutions of higher education.

Diagram 3 shows a state that has three boards for these purposes. One is a state board of education, which is responsible for general supervision of elementary and secondary schools. Another is a state board for vocational education, which is responsible for administration of vocational education programs. The third is a state board for higher education, which is responsible for coordination or governance of public institutions of higher education.

The next two diagrams (Exhibit 5) show the difference between expectations and developments in many states with regard to the establishment or designation of state postsecondary education commissions.

Diagram 4 reveals an expectation that the state commission would be a separate agency. Diagram 5 indicates what happened instead. The state board for higher education was either designated or augmented to meet the requirements of Section 1202.

The last diagram (Exhibit 6) shows the nature of efforts made in at least two or three states to meet representation requirements by appointing an advisory committee. This would not have been permitted if the Commissioner had issued the proposed rules and regulations, but it corresponds to the approach used in the Vocational Education Act to obtain representation of specific groups in the planning process.

#### **Structures, Relationships, and Grants**

Let us turn now to some topics that are more closely related to coordination of program developments in postsecondary vocational education. These involve relationships among state agencies and the flow of funds to postsecondary institutions.



Exhibit 4

BASIC PATTERNS AMONG STATE EDUCATIONAL AGENCIES

Diagram 1

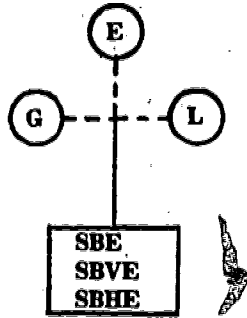

Diagram 2

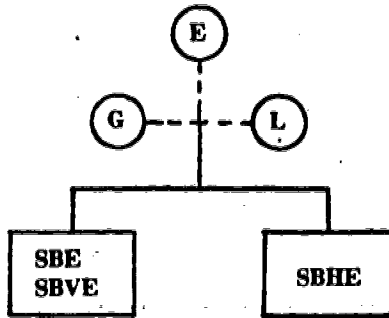
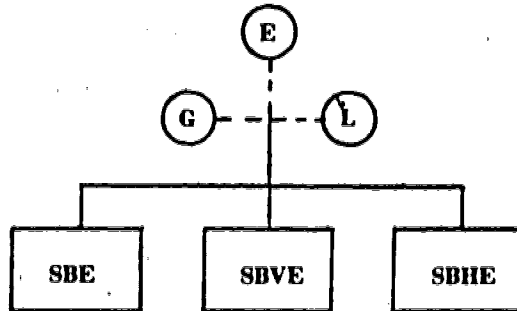

Diagram 3



Code: E — Electorate; G — Governor; L — Legislature; SBE — State Board of Education; SBVE — State Board for Vocational Education; SBHE — State Board for Higher Education

Exhibit 5

✓ EXPECTATIONS REGARDING DESIGNATION OR ESTABLISHMENT OF STATE POSTSECONDARY EDUCATION COMMISSIONS

Diagram 4

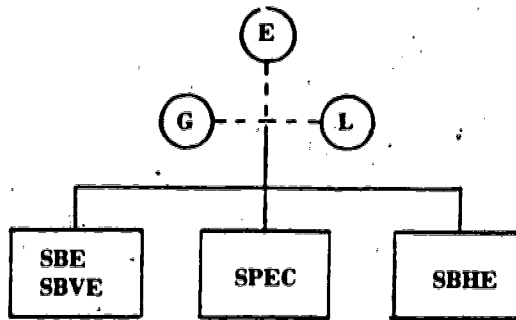
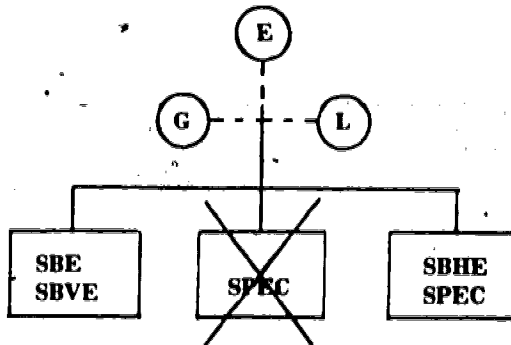

Diagram 5



Code: E — Electorate; G — Governor; L — Legislature; SBE — State Board of Education; SBVE — State Board for Vocational Education; SBHE — State Board for Higher Education; SPEC — State Postsecondary Education Commission

Exhibit 6

**EFFORTS TO IMPROVE REPRESENTATION ON  
STATE POSTSECONDARY EDUCATION COMMISSIONS**

Diagram 6

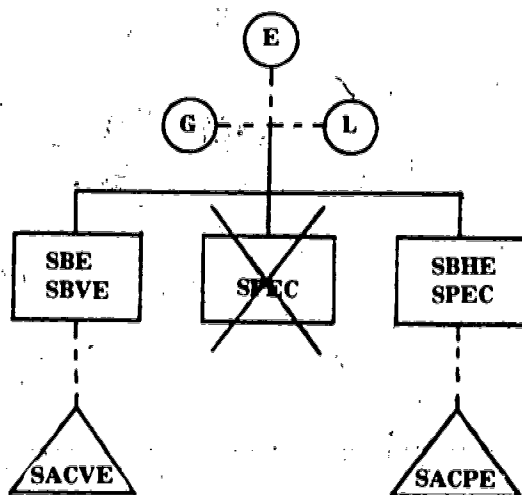

Code: E — Electorate; G — Governor; L — Legislature; SBE — State Board of Education; SBVE — State Board for Vocational Education; SBHE — State Board for Higher Education; SPEC — State Postsecondary Education Commission; SACVE — State Advisory Council on Vocational Education; SACPE — State Advisory Council on Postsecondary Education

Exhibit 7 is a modified and expanded version of Diagram 5 which shows the situation in most states at this time if we ignore certain complexities related to state structures for coordination or governance of institutions of higher education. Three assumptions are necessary. First, it is assumed that the state board of education is responsible for the general supervision of all public elementary and secondary schools (ES and SS) and all public vocational schools (VS — including technical institutes). Second, it is assumed that the state board for higher education is responsible for coordination or governance of all state colleges (SC) and all state universities (SU). And third, it is assumed that either board may be responsible for general supervision, coordination, or governance of some or all community colleges.

This diagram has two significant features. First, it shows that the state advisory council on vocational education (SACVE) is responsible to the state board of education in its role as the state board for vocational education. Second, it reveals that funds obtained from grants under the Vocational Education Act flow through one board to institutions which are coordinated or governed by another board. This has led to accusations in some states that funds are not distributed equitably among all institutions. It has also led to claims that there has been needless duplication of programs and facilities.

#### **Proposed Amendments**

This brings us to the subject of proposed amendments to the Vocational Education Act. Five bills need to be considered.<sup>6</sup> Four of them were introduced in both the House and Senate during the first six months of last year. The fifth was introduced in the Senate during November.

The first four bills were drafted by the American Vocational Association (AVA), the American Association of Community and Junior Colleges (AACJC), the National Association of State Universities and Land Grant Colleges (NASULGC), and the Administration. The fifth bill was drafted by Senator Pell and his staff.

The following sections will concentrate on proposals related to planning and administration of postsecondary programs at the state level. No attempt will be made to describe other features of these bills which relate to programs at the secondary level or areas of responsibility at the national level.

#### **AVA Bill (H.R. 3037 and S. 941)**

The bill drafted by the American Vocational Association (AVA) is an amended version of existing legislation which is divided into five parts: Part A — General Provisions; Part B — Career Guidance and Exploration; Part C — Vocational Education Program Support; Part D — Vocational Education Program Services; and Part E — Applied Research, Curriculum Development, Demonstration Programs, and Leadership Development.

Part A contains provisions related to planning and administration of programs. It has nine sections, as shown in Exhibit 8. Major features for our purposes can be found in Sections 102, 107, and 108.

Section 102 is a new section on state administration that would strengthen the role of the state board for vocational education as the sole agency for administration of the state plan. It would do this in several ways. First, it would

Exhibit 7

STRUCTURES, RELATIONSHIPS, AND GRANTS  
IN MOST STATES DURING 1975

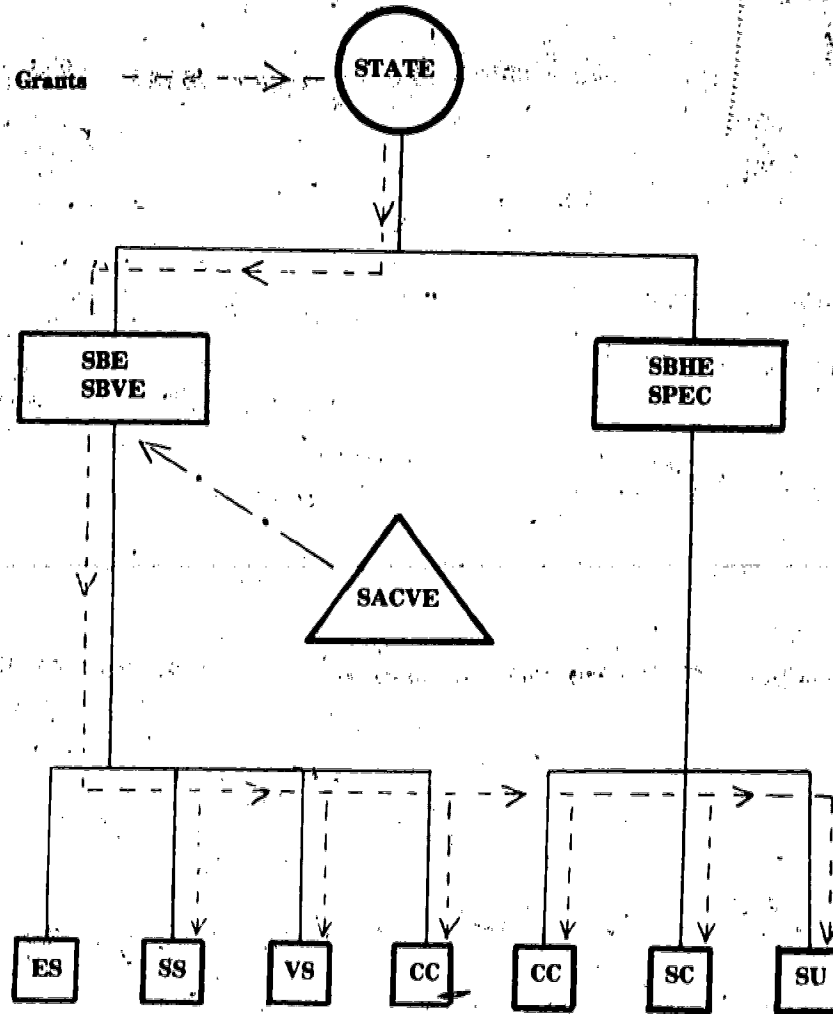

Exhibit 8

**OUTLINE OF PROVISIONS IN PART A OF THE AVA BILL  
[H.R. 3037 and S. 941]**

- Sec. 101 Declaration of Purpose
- 102 State Administration
- 103 Leadership in Vocational Education
- 104 Limitation
- 105 Periodic Review of Vocational Education Programs and Laws
- 106 National Advisory Council on Vocational Education
- 107 State Advisory Councils of Vocational Education
- 108 Comprehensive Statewide Planning and Accountability for Vocational Education
- 109 Definitions

require the state board to serve as the sole agency for administration of the state plan and for supervision of administration by local educational agencies. Second, it would specify that the board must serve as the sole agency for determining final policy for fiscal management and administration. Third, it would require the board to adopt administrative arrangements providing certain assurances to the Commissioner regarding its activities. And fourth, it would require the Commissioner to approve these arrangements.

The administrative arrangements would have to include assurances that the state board has not delegated final authority for policy-making to other agencies; that the federal government is working directly with the board in all matters related to vocational education; and that the board has prepared statewide planning documents which consist of plans for at least four but not more than six years, which are prepared on a fiscal basis, and which are filed or updated with the Commissioner biennially.

Section 107 would amend provisions related to state advisory councils. One amendment would state explicitly that the council must be an "independent" body; another would result in several changes regarding the nature of representation; another would require appropriate representation on the basis of sex, geography, and membership in minority groups; another would limit evaluation of programs, services, and activities to statewide matters; and another would require the council to prepare and submit its annual evaluation reports through the state board for vocational education to the Committee on Education and Labor of the House of Representatives and the Committee on Labor and Public Welfare of the Senate.

Section 108 is a new section on comprehensive statewide planning and accountability for vocational education. Among other things, it would give the state board primary responsibility for preparing comprehensive statewide plans; it would require designation of a planning group to formulate the plans; it would list seven requirements that the planning group would have to meet in doing this; it would require the Commissioner to promulgate guidelines for the formulation of plans to assure uniformity among the states; and it would require issuance of an accountability report concurrently with the presentation of each biennial state plan indicating the extent to which the state has achieved its goals. One of the seven requirements that the planning group would have to meet calls for it "to consult with and obtain the assistance of other appropriate State agencies...."

Exhibit 9 shows the impact that this bill would have on structures and relationships in states where a state board of education serves as the state board for vocational education and a state board for higher education serves as the state postsecondary education commission. Funds would continue to flow through the state board of education to institutions under its supervision as well as those responsible to the state board for higher education. The state advisory council would also continue to have responsibilities only to the state board of education in its role as the state board for vocational education. However, it is assumed that the state board for vocational education would "consult with and obtain the assistance of" the state board for higher education as one of the state agencies referred to in Section 108.

#### **Administration Bill [H.R. 6251 and S. 1863]**

The bill drafted by the Administration is also an amended version of existing legislation. It has four titles as follow: Title I — General Provisions; Title II — Program Planning; Title III — Vocational Education Programs and Services; and

Exhibit 9  
IMPACT OF AVA BILL

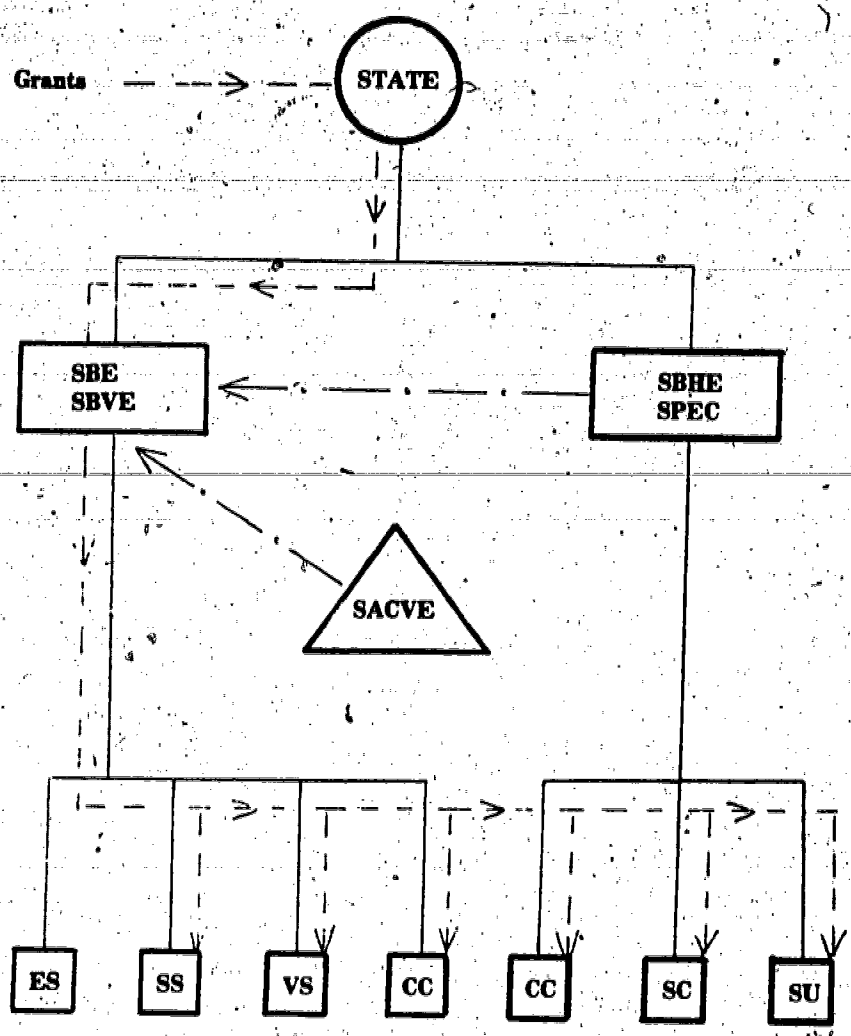



#### Title IV — Grants for Research, Innovation, and Demonstration.

Titles I and II contain provisions related to planning and administration of programs. The various sections are listed in Exhibit 10. Major provisions for our purposes can be found in Sections 103, 106, 202, and 203.

Section 103 would require any state desiring to participate in programs authorized by this legislation to designate or establish a state board "consistent with state law" which would be the sole state agency for administration of such programs. Responsibilities would include development of policy related to these programs, development and submission of state plans, and consultation with the state advisory council for vocational education as well as "other appropriate State planning agencies." Except for the responsibilities, the board would be permitted to delegate responsibility for operating and supervising programs to other appropriate state agencies.

Section 106 would require any state desiring to receive a grant under this legislation to establish an advisory council which would be "independent" and whose members would be representative of both governmental and non-governmental interests. Members would be appointed either by the governor or an elected state board of education. The governor or the elected board would be required to include persons who represent 19 specified categories and to insure appropriate representation of both sexes, racial and ethnic minorities, and the various geographic regions of the state. Areas of responsibility would call for the council (1) to advise the state board for vocational education on the development of state plans; (2) to advise the board on policy matters arising in the administration of programs; (3) to evaluate programs, services, and activities assisted under this legislation; (4) to prepare and submit an annual report, and (5) to assist the board in encouraging the development and installation of local program planning.

Section 202 would require any state desiring to participate in programs authorized by this legislation to prepare "through its State board" a five-year forward plan for vocational education. The plan would meet the requirements of this section if it (1) is prepared in consultation with the state advisory council, (2) provides a long-range assessment of vocational education needs and established long-range program objectives related to those needs, (3) considers the requirements of persons with special needs for vocational education opportunities and provided long-range program objectives related to those needs, and (4) provides for the involvement of "other appropriate public and private agencies, organizations and institutions in the development of the plan." This section would also require the plan to be submitted to the Commissioner not later than June 30, 1976, and to be updated "if necessary" in conjunction with the preparation of the annual program plan.

Section 203 would require an annual program plan which meets ten stated requirements. One of these would call for a plan that has been prepared in consultation with the state advisory council and other appropriate public and private agencies, organizations, and institutions. Another would call for a plan that indicates how and to what extent the programs, services, and activities to be carried out will address the critical national needs and high national priorities identified by the Commissioner.

Exhibit 11 shows the impact that the Administration bill would have on state

Exhibit 10

OUTLINE OF PROVISIONS IN TITLE I AND TITLE II  
OF THE ADMINISTRATION BILL  
[H.R. 6251 and S. 1863]

Title	Section	Heading
I	Sec. 101	Purpose
	Sec. 102	Authorization of Appropriations
	Sec. 103	State Administration
	Sec. 104	Allotments among States
	Sec. 105	National Advisory Council for Vocational Education
	Sec. 106	State Advisory Councils for Vocational Education
	Sec. 107	Limitations on Payments
	Sec. 108	Definitions
	Sec. 109	Effective Date; Repealer
II	Sec. 201	Annual Assessment of National Vocational Education Needs and Priorities
	Sec. 202	Forward Plan
	Sec. 203	Annual Program Plan
	Sec. 204	Availability of Funds for Planning Activities

Exhibit 11

IMPACT OF ADMINISTRATION BILL

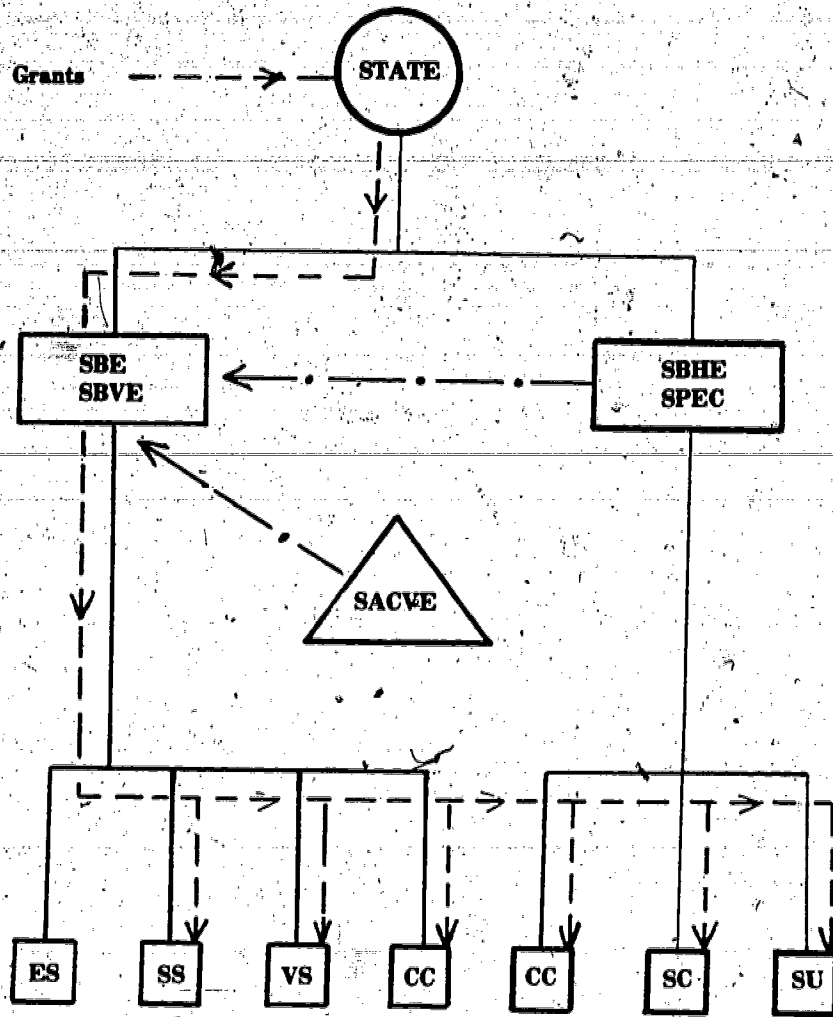

structures and relationships. There is no difference, of course, between this diagram and the one for the AVA bill.

**AACJC Bill [H.R. 3036 and S. 939]**

The bill drafted by the American Association of Community and Junior Colleges (AACJC) is divided into 12 sections as shown in Exhibit 12. Each contains one or more amendments to existing legislation. Major provisions related to planning and administration of programs can be found in Sections 2 to 5.

**Section 2** reflects the main purpose of the bill. It would require separation of allotments for state vocational education programs into two parts, one to be known as the "secondary vocational education allotment" and the other as the "postsecondary occupational education allotment." Each would equal 40 percent of the total, with the remaining 20 percent to be disbursed by the Commissioner according to recommendations of a State Board for Allotment of Federal Vocational Funds appointed by the governor.

**Section 3** would amend Part B of existing legislation by adding four new sections designated as Sections 125 to 128 under the heading "Subpart 2 — Occupational Education Programs."

**Section 125** authorizes the Commissioner to make grants to states from their respective occupational education allotments to assist them in conducting programs for persons "of postsecondary age."

**Section 126** gives Section 1202 state commissions responsibility for submitting applications related to these grants, specifies that allotments must be used to strengthen state advisory councils and to support comprehensive planning by state commissions, lists activities that must be included in this planning, requires that 75 percent of the allotments for a given year must be used only for programs and activities at community colleges, states that allotments may not be used for programs of area secondary vocational education, specifies purposes for which grants must be made, and authorizes contractual arrangements with private organizations and institutions organized for profit.

**Section 127** requires state plans for occupational education that meet six stated requirements, including a requirement that plans are prepared by Section 1202 state commissions in consultation with state advisory councils.

**Section 128** limits payments from allotments for a fiscal year to 50 per cent of total expenditures made in carrying out these plans.

**Section 4** would amend provisions related to national and state advisory councils. One amendment would change the name of the National Advisory Council on Vocational Education to National Advisory Council on Vocational and Occupational Education. Another would require state advisory councils to be appointed by the governor in every state regardless of whether members of the state board might be elected or appointed. Still another would add provisions that assure representation of community and junior colleges on these councils.

**Section 5** would add a new section to Part A designated as Section 109 which would require establishment of local coordinating committees to be appointed by the governor according to criteria prescribed by the Commissioner. Each com-

Exhibit 12

**OUTLINE OF PROVISIONS IN AACJC BILL**

[H.R. 3036 and S. 939]

- Sec. 1 Cited as the "Postsecondary Vocational Education Act of 1975"
- Sec. 2 Establishment of Separate Allotments for Vocational Education and Occupational Education
- Sec. 3 Occupational Education
- Sec. 4 Amendments of National and State Advisory Committee Provisions
- Sec. 5 Local Coordinating Committees
- Sec. 6 Amendment of Declaration of Purpose
- Sec. 7 Amendments of Definitions
- Sec. 8 Amendments Relating to Vocational Education Programs
- Sec. 9 Limitation on Use of Federal Funds for Administrative and Support Services
- Sec. 10 Extension and Amendment of Authorization of Appropriations
- Sec. 11 Consolidation of Programs for Research and Training, Exemplary Programs and Projects, and Curriculum Development
- Sec. 12 Effective Date

mittee would include members representative of stated categories and would make a continuing study of local needs for vocational education, occupational education, and manpower training programs, with results to be transmitted to specified agencies.

Exhibit 13 shows the impact that the AACJC bill would have on structures and relationships in most states. Funds would be divided initially among three boards in a 40:20:40 ratio with a requirement that the 20 per cent be disbursed according to recommendations of the SBAFVF. The state advisory council would have responsibilities related to the state board for vocational education and the state postsecondary education commission. Each of these in turn would be required to consult with the council in preparing state plans. And finally, it should be noted that funds for postsecondary occupational education might flow through the state board for higher education to institutions under the state board of education.

#### **NASULGC Bill [H.R. 4797 and S. 942]**

The bill drafted by the National Association of State Universities and Land-Grant Colleges (NASULGC) contains 13 sections, as shown in Exhibit 14. The first nine would amend the Vocational Education Act (VEA). The last four would amend the Higher Education Act (HEA), including Sections 1202 and 1203. Major provisions appear in Sections 4 to 6 and 10 to 11.

Section 4 would amend provisions related to allotments for state vocational education programs in Parts A and B of the VEA by means of two subsections. Subsection (a) would amend Part A by adding a new section designated as Section 110 which would require applications for funding to include five types of information related to separate allotments for "vocational education programs" and "postsecondary occupational education programs." Subsection (b) would amend Part B by inserting the words "Subpart 1 — Vocational Education Programs" before the title of Section 121 and by amending Sections 121 and 124 so they would be restricted to such programs.

The five types of information to be included in applications for funding may be summarized as follows: (1) assurance that the allotment for a fiscal year would be divided into two parts, one to be known as the "vocational education allotment" and the other to be known as the "postsecondary occupational education allotment"; (2) assurance that each part would equal not less than 40 percent of the total; (3) provision of a mechanism or procedure consistent with state law and state organizational structure for a joint determination by the state board for vocational education and the Section 1202 state commission of the most effective and equitable allocation of the remaining 20 percent; (4) provision of a mechanism or procedure which would give reasonable promise for resolving differences between various types of educators and other interested groups; and (5) an agreement to submit to the Commissioner the state plans and documents required for both types of allotments.

Section 5 would amend Part B of the VEA by adding six new sections designated as Sections 125 to 130 under the heading "Subpart 2 — Postsecondary Occupational Education Programs."

Section 125 would authorize a state to use funds from its postsecondary occupational education allotment to carry out the activities set forth in Section 126 provided it has met the requirements set forth in Section 127.

Exhibit 13

IMPACT OF AACJC BILL

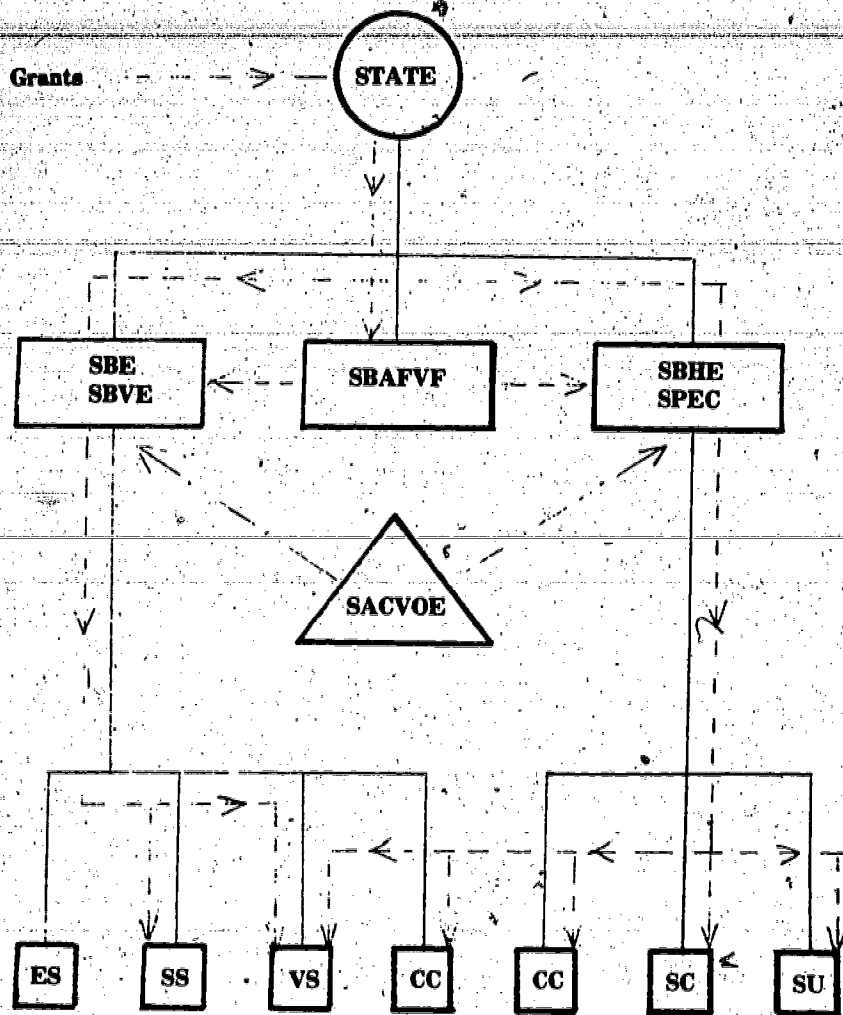

Exhibit 14

**OUTLINE OF PROVISIONS IN NASULGC BILL  
(H.R. 4797 and S. 942)**

**Amendments to the Vocational Education Act**

- Sec. 1 Cited as the "Postsecondary Vocational Education Act of 1975"
- Sec. 2 Amendment Pertaining to Declaration of Purpose
- Sec. 3 Definition of Postsecondary Occupational Education
- Sec. 4 Establishment of Separate Allotments for Vocational and Occupational Education
- Sec. 5 Postsecondary Occupational Education
- Sec. 6 Amendments to National and State Advisory Council Provisions
- Sec. 7 Technical Amendments to Parts C through J of the Vocational Education Act of 1963
- Sec. 8 Effective Date (Sections 1 through 7)
- Sec. 9 Planning Grants

**Amendments to the Higher Education Act**

- Sec. 10 Amendments to Section 1202
- Sec. 11 Amendments to Section 1203
- Sec. 12 Amendments to Section 1204
- Sec. 13 Effective Date (Sections 10 through 12)



Section 126 would provide that funds from this allotment could be used only for programs "to promote access to" postsecondary occupational education and related activities involving planning, administration, and evaluation by state agencies.

Section 127 lists seven requirements that a state would have to meet in relation to its application of funds. These would involve: (1) designation of the state commission established under Section 1202 of the Higher Education Act as the state commission to carry out planning for programs to promote access to postsecondary occupational education; (2) designation or establishment of a state agency authorized in accordance with state law as the state agency for disbursement of the postsecondary occupational education allotment and for proper fiscal control and accounting of funds; (3) assurance that funds would be used only for the purposes set forth in Section 126 and in a manner consistent with the requirements of Section 128; (4) assurance that the commission would undertake a continuous program of planning in consultation with appropriate state agencies and institutions and in accordance with the requirements of Section 128; (5) assurance that the state commission would evaluate the use of funds annually with participation by the state advisory council; (6) a requirement that each institution which receives funds would use them only for approved programs and provide assurance that these funds would be used to supplement and not supplant funds from other sources; and (7) a provision that the allotment would pay for not more than 50 per cent of total expenditures for postsecondary occupational education programs and related activities.

Section 128 would require the state commission to undertake a continuous program of statewide planning for postsecondary occupational education which would meet six stated objectives. It would also require this commission to prepare an annual state plan, with the advice of the state advisory council, which would serve as the basis for disbursement of funds and meet six additional objectives.

Section 129 would authorize disbursement of funds to postsecondary occupational education institutions in accordance with the state plan for programs to promote access to postsecondary occupational education. Six types of programs are listed as examples of what should be done.

Section 130 would require the Commissioner to give special attention to evaluation of the various means for promoting access to postsecondary occupational education in making annual evaluative reports to the Senate and House education committees.

Section 6 would amend provisions related to national and state advisory councils. First, it would change the name of the National Advisory Council on Vocational Education to National Advisory Council on Vocational and Postsecondary Occupational Education. Second, it would change the nature of representation on the state advisory council to include a person or persons representative of "community and junior colleges and other postsecondary occupational education institutions." Third, it would add a new paragraph calling for the state advisory council to advise the state commission established under Section 127 with respect to planning and evaluation of postsecondary occupational education.

Section 10 would amend Section 1202 of the Higher Education Act in several ways, including elimination of requirements for representation on state post-secondary education commissions.

Subsection (a) provides that any state desiring to receive certain kinds of assistance under the Higher Education Act or the Vocational Education Act after September 30, 1976, must submit a state plan to the Commissioner which meets the following requirements: (1) designates or establishes a state commission in accordance with state law that will be responsible for comprehensive statewide planning for postsecondary education; (2) sets forth the means to be used in accordance with state law and unique state circumstances to assure direct and active participation by representatives of the general public and various types of postsecondary institutions in the planning process; (3) sets forth a plan of administration to assure that the state agencies and state commissions required by the Higher Education Act and the Vocational Education Act are administered in a manner consistent with this planning; (4) sets forth the criteria and means to be used by the state to evaluate the effectiveness of the planning and related requirements; and (5) provided for submission of an annual report to the Commissioner not later than August 1 of each year beginning in the fiscal year 1977 which contains information about revisions in the state plan, results of evaluations, and other information required to assess the response of the state to the requirements of this section.

Section 11 contains an amended version of Section 1203 in the Higher Education Act which has three main features. First, it would clearly refer to comprehensive statewide planning for all postsecondary educational resources. Second, it would not contain a reference to Title X. And third, it would require the Commissioner to promulgate regulations containing criteria to be used in evaluating applications for grants.

Exhibit 15 shows the impact that the NASULGC bill would have on structures and relationships in most states. Funds would be divided initially on a 40-20-40 basis, but each state would determine for itself how to distribute the 20 per cent. The state advisory council would have responsibilities related to the state board for vocational education and the state postsecondary education commission. Each of these in turn would be required to consult with the council in preparing state plans. Again, it should be noted that funds for postsecondary occupational education might flow through the state board for higher education to institutions under the state board of education.

#### Pell Bill [S. 2657]

The bill introduced by Senator Pell contains four titles as follows: Title I — Higher Education; Title II, — Vocational Education; Title III — Extensions of Other Related Education Programs; and Title IV — Education Administration.

Title I contains one provision that must be mentioned here. It would repeal Part B of Title X in the Higher Education Act.

Title II would amend the Vocational Education Act by extending existing legislation for two years and then revising it for 1978 and subsequent years. Proposed revisions are divided into seven parts as follows: Part A — State Vocational Education Programs; Part B — Ancillary Services; Part C — Innovation; Part D — Student Programs; Part E — Emergency Assistance for Remodeling and Renovation of Vocational Education Facilities; Part F — Consumer and Homemaking Education; and Part G — General Provisions.

Exhibit 15  
IMPACT OF NASULGC BILL

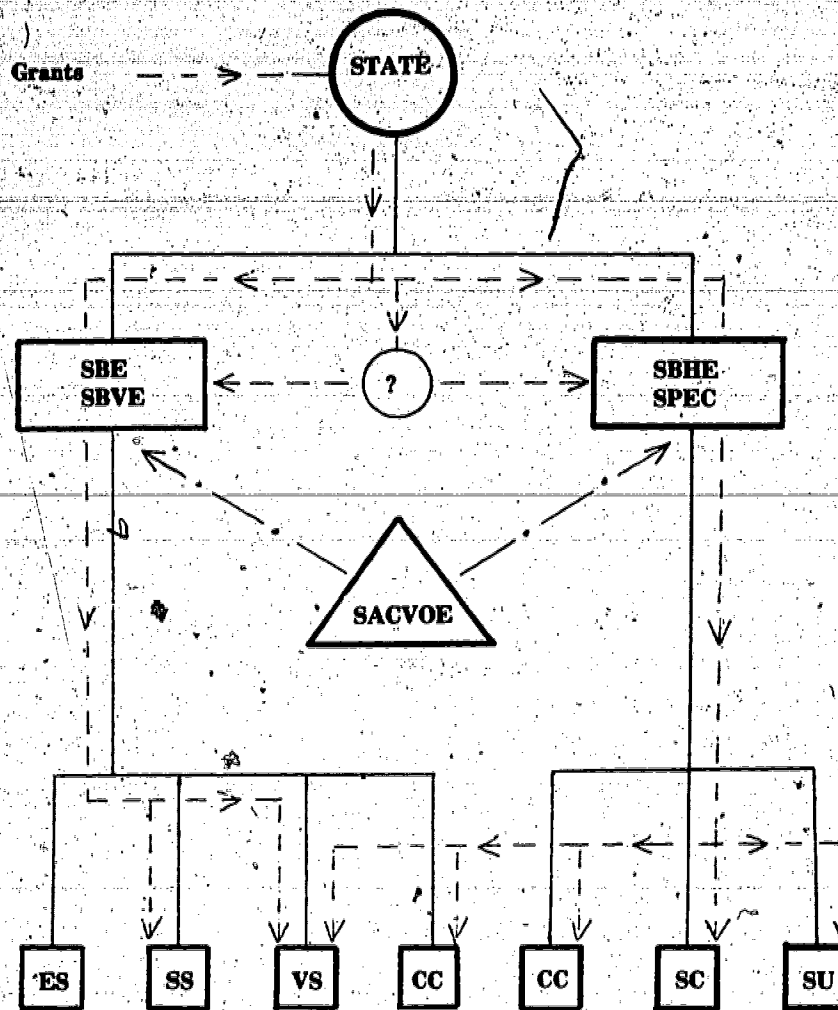

Parts A and G contain provisions related to planning and administration of programs. Part A contains eleven sections designated as Sections 101 to 111. Part G contains 2 sections designated as Sections 171 to 172. Headings are shown in Exhibit 16. Sections 101, 104, 105, 106, and 108 are most important here.

Section 101 would amend the declaration of purpose by stressing assistance to states in improving planning for vocational education and manpower training. Related phrases mention use of all available resources, equitable distribution of funds, and involvement of a wide range of agencies and individuals.

Section 104 requires a State Board for Vocational Education which would be designated or established in accordance with state law and would serve as the sole state agency for development of policy, preparation of long-range and annual program plans, and consultation with the State Advisory Council for Vocational Education and "other appropriate State planning agencies." This board would be allowed to delegate responsibility for administration, operation, and supervision of vocational education programs.

Membership would have to include the chief state school officer or his representative, the state director of vocational education, a representative of the state agency responsible for community and junior colleges, a representative of the state agency responsible for institutions of higher education, a representative of the state agency responsible for adult education programs, a representative of the state manpower services council, and one representative each of business, industry, labor, agriculture, and the general public.

Section 105 would amend provisions related to membership on state advisory councils by expanding the number of categories to be represented from nine to sixteen. These would include a separate category for community and junior colleges. The state advisory councils would be given clear responsibility for advising the state board in the development of long-range and annual program plans.

Section 106 would require a comprehensive statewide long-range plan covering a period of four to six years which would set forth "manpower and vocational education goals" and specify how available funds would be used to achieve these goals. The state board would be expected to meet four stated requirements in developing such a plan, including a requirement that it "give thorough consideration to the most effective means of utilizing all existing institutions within the State capable of carrying out or supervising the kinds of programs assisted under this Act...."

Section 108 would require an annual program plan which meets six stated conditions for approval by the Commissioner. One of these would require the state advisory council to be "actively involved in all stages of development of the annual program plan." Another would require consultation by the state board with the state manpower services council.

Exhibit 17 shows the impact that the Pell bill would have on structures and relationships in most states. Funds would flow through the state board for vocational education to institutions responsible in other ways to the state board of education and the state board for higher education. The state advisory council would be responsible only to the state board for vocational education. Both the

Exhibit 16

OUTLINE OF PROVISIONS IN PARTS A AND G  
OF TITLE II IN THE PELL BILL

Part	Section	Heading
A	101	Declaration of Purpose
	102	Authorization of Appropriations; Uses of Funds
	103	Allotments among States
	104	State Board for Vocational Education
	105	State Advisory Councils on Vocational Education
	106	Comprehensive Statewide Long-Range Plans
	107	General Application
	108	Annual Program Plan
	109	Withholding and Judicial Review
	110	Persons with Special Needs
	111	Payments to States
G	171	Definitions
	172	National Advisory Council on Vocational Education

Exhibit 17  
IMPACT OF PELL BILL

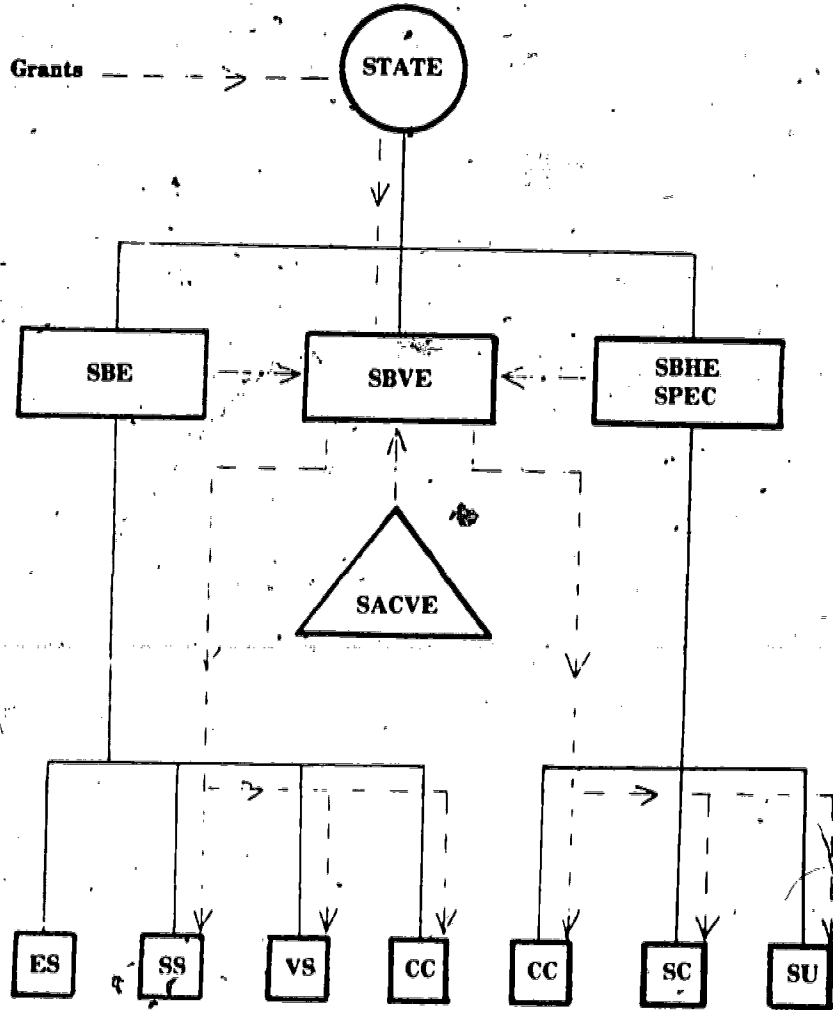

state board of education and the state board for higher education would be involved in consultation with the state board for vocational education as "other appropriate State planning agencies" referred to in Section 104. Each would also be represented in terms of membership on the board.

#### Conclusion

Careful examination of proposed amendments to the Vocational Education Act indicates that the main issue related to coordination of vocational education at the postsecondary level involves the nature of the state board to be given responsibility for planning and administration of such programs.<sup>7</sup>

The five bills described above offer three basic alternatives. One is to maintain the concept of a sole state agency and allow states to continue designating the state board of education as the state board for vocational education, including occupational education. This is reflected in bills drafted by the AVA and the Administration.

A second alternative would abandon the concept of a sole agency and divide responsibility for planning of programs between the state board for vocational education and the state postsecondary education commission. This is reflected in the bills drafted by the AACJC and the NASULGC.

The third alternative would maintain the concept of a sole state agency but require specific types of presentation which would probably result in the establishment of a separate agency in most states. This is reflected in the Pell bill.

These alternatives demand immediate attention from all persons interested in the coordination of vocational or occupational programs at the postsecondary level.

#### FOOTNOTES

<sup>1</sup>U.S. Congress. *A Compilation of Federal Education Laws, As Amended Through December 31, 1974*. (Washington: U.S. Government Printing Office, 1975), pp. 481-516.

<sup>2</sup>*Public Law 92-518*, 92nd Congress, S. 659, Education Amendments of 1972, pp. 89-90 and 77-88.

<sup>3</sup>A good starting point is U.S. Congress, *State Postsecondary Education Commissions*, Oversight Hearings before the Special Subcommittee on Education of the Committee on Education and Labor, House of Representatives, 93rd Congress, 1st Session (Washington: U.S. Government Printing Office, 1973).

<sup>4</sup>Aims C. McGuinness, T. Harry McKinney, and Richard M. Millard, *The Changing Map of Postsecondary Education* (Denver: Education Commission of the States, April 1975), pp. 75-80.

<sup>5</sup>These diagrams were presented originally in T. Harry McKinney's "Section 1202 State Commissions: Patterns of Development and Related Concerns," in *Current Status, Planning and Prospects of the 1202 State Postsecondary Commissions*, by Robert H. Fonske and Kerry D. Romesburg, eds. (Tempe: Center for the Study of Higher Education, Arizona State University, April 1975), pp. 7-24.

<sup>6</sup>This section relies heavily on information presented in a report for the U.S. Office of Education entitled *Administration of the Section 1203 Comprehensive Statewide Planning Grants Program* to be released in the near future. Bills drafted by the AVA, AACJC, and NASULGC appear in the *Congressional Record* for March 4, 1975, on pages S-2957 to S-2976. A summary of the bill drafted by the Administration appears in the *Congressional Record* for June 4, 1975, on pages S-9531 to S-9533. The bill drafted by Senator Pell appears in the *Congressional Record* for November 12, 1975, on pages S-19722 to S-19734.

For information about other issues related to the various bills, see Pamela H. Christoffell, *Vocational Education: Alternatives for New Federal Legislation* (New York: College Entrance Examination Board, 1975).